

**WARNING**

Operator and maintenance personnel should be familiar with the requirements of TB-385-4 before attempting installation or operation of the equipment. Failure to follow the requirements of TB-385-4 could result in injury or DEATH.

**DON'T TAKE CHANCES!**

**DANGEROUS RF VOLTAGES, UP TO 2,000 V, MAY EXIST WITHIN THE AN/GRM-114 WHILE THE UNIT IS OPERATING. AVOID RADIO FREQUENCY BURNS.**



SAFETY STEPS TO FOLLOW IF SOMEONE  
IS THE VICTIM OF ELECTRICAL SHOCK

- ① DO NOT TRY TO PULL OR GRAB THE INDIVIDUAL
- ② IF POSSIBLE, TURN OFF THE ELECTRICAL POWER
- ③ IF YOU CANNOT TURN OFF THE ELECTRICAL POWER, PULL, PUSH, OR LIFT THE PERSON TO SAFETY USING A WOODEN POLE OR A ROPE OR SOME OTHER INSULATING MATERIAL
- ④ SEND FOR HELP AS SOON AS POSSIBLE
- ⑤ AFTER THE INJURED PERSON IS FREE OF CONTACT WITH THE SOURCE OF ELECTRICAL SHOCK, MOVE THE PERSON A SHORT DISTANCE AWAY AND IMMEDIATELY START ARTIFICIAL RESUSCITATION

# C A U T I O N

**THIS EQUIPMENT CONTAINS PARTS  
AND ASSEMBLIES SENSITIVE TO  
DAMAGE BY ELECTROSTATIC DISCHARGE (ESD).  
USE ESD PRECAUTIONARY PROCEDURES  
WHEN TOUCHING, REMOVING OR INSERTING  
PRINTED CIRCUIT BOARDS.**

## **ESD CLASS 1**

### GENERAL HANDLING PROCEDURES FOR ESDS ITEMS

- I USE WRIST GROUND STRAPS OR MANUAL GROUNDING PROCEDURES
- I KEEP ESDS ITEMS IN PROTECTIVE COVERING WHEN NOT IN USE
- I GROUND ALL ELECTRICAL TOOLS AND TEST EQUIPMENT
- I PERIODICALLY CHECK CONTINUITY AND RESISTANCE OF GROUNDING SYSTEM
- I USE ONLY METALIZED SOLDER SUCKERS
- I HANDLE ESDS ITEMS ONLY IN PROTECTED AREAS

### MANUAL GROUNDING PROCEDURE

- I MAKE CERTAIN EQUIPMENT IS POWERED DOWN
- I TOUCH GROUND PRIOR TO REMOVING ESDS ITEMS
- I TOUCH PACKAGE OF REPLACEMENTS ESDS ITEM TO GROUND BEFORE OPENING
- I TOUCH GROUND PRIOR TO INSERTING REPLACEMENT ESDS ITEMS

### ESD PROTECTIVE PACKAGING AND LABELING

- I INTIMATE COVERING OF ANTISTATIC MATERIAL WITH AN OUTER WRAP OF EITHER TYPE 1 ALUMINIZED MATERIAL OR CONDUCTIVE PLASTIC FILM - O R - HYBRID LAMINATED BAGS HAVING AN INTERIOR OF ANTISTATIC MATERIAL WITH AN OUTER METALLIZED LAYER
- I LABEL WITH SENSITIVE ELECTRONIC SYMBOL AND CAUTION NOTE

TECHNICAL MANUAL }  
 NO. 11-6625-3016-14 }

HEADQUARTERS  
 DEPARTMENT OF THE ARMY  
 Washington, D.C., 18 June 1982

**OPERATOR'S, ORGANIZATIONAL, DIRECT' SUPPORT,  
 AND GENERAL SUPPORT MAINTENANCE MANUAL  
 TEST SET, RADIO AN/GRM-114**

**IFR NO. FM/AM-1000S,  
 MM-100/W PB-114,  
 ( AC-114 ACCESSORY KIT )  
 (NSN 6625-01-108-6206)**

**REPORTING ERRORS AND RECOMMENDING IMPROVEMENTS**

You can help improve this manual. If you find any mistakes or if you know of a way to improve the procedures, please let us know. Mail your letter, DA Form 2028 (Recommended Changes to Publications and Blank Forms), or DA 2028-2 located in back of this manual direct to Commander, US Army Communications-Electr[onics Command, ATTN: DRSEL-ME-MQ, Fort Monmouth, New Jersey, 07703.

In either case, a reply will be furnished direct to you.

**TABLE OF CONTENTS**

		Paragraph	Page
<b>CHAPTER 1.</b>	<b>INTRODUCTION</b>		
Section L	General		
	Scope	1-1	1-1
	Maintenance forms, records, and reports	1-2	1-1
	Reporting equipment improvement recommendations	1-8	1-1
	Administrative storage	1-4	1-1
	Destruction of Army electronics materiel	1-5	1-1
<b>II.</b>	<b>Description and data</b>		
	Purpose	1-6	1-1
	use	1-7	1-1
	Description and capabilities	1-8	1-1
	Equipment characteristics	1-9	1-1
	Items supplied	1-10	1-6
	Items required (but not supplied)	1-11	1-6
	Warranty information	1-12	1-7
	Safety precautions	1-13	1-8

	Paragraph	Page
CHAPTER 2.	PREPARATION FOR USE AND INSTALLATION	
	Unpacking	2-1 2-1
	Assembly	2-2 2-1
	Checking unpacked equipment	2-3 2-1
	Siting	2-4 2-1
	Installation instructions	2-5 2-1
	Power requirements	2-6 2-3
	Initial checks and alignment	2-7 2-3
CHAPTER 3.	THEORY OF OPERATION	
	General theory	3-1 3-1
	Receive theory	3-2 3-1
	Generate theory	3-3 3-4
	Frequency error theory	3-4 3-6
	1st local oscillator theory	3-5 3-8
	2nd local oscillator theory	3-6 3-8
	Dual tone generator theory	3-7 3-8
	Oscilloscope theory	3-8 3-12
	Spectrum analyzer theory	3-9 3-14
	MM-100 (Multimeter) theory	3-10 3-14
	Power supply theory	3-11 3-18
CHAPTER 4.	OPERATING INSTRUCTIONS	
	Operating procedures	4-1 4-1
	AN/GRM-114 controls, indicators, and connectors	4-2 4-1
	Operating procedures	4-3 4-13
	RF signal generator operating instructions	4-4 4-13
	Oscilloscope operating instructions	4-5 4-24
	Receiver operating instructions	4-6 4-28
	Spectrum analyzer operating instructions	4-7 4-37
	Audio generator operating instructions	4-8 4-48
	Power monitor function	4-9 4-58
	Master oscillator calibration	4-10 4-58
	Frequency error measurement	4-12 4-65
	Audio frequency monitor function	4-13 4-70
	Multimeter operating instructions	4-14 4-70
CHAPTER 5.	MAINTENANCE INSTRUCTIONS	
	General	5-1 5-1
	AN/GRM-114 routine maintenance checks and services	5-2 5-1
	Tools and test equipment	5-3 5-1
	Glossary	5-4 5-4
	AN/GRM-114 performance test	5-5 5-4
	AN/GRM-114 troubleshooting	5-6 5-6
	AN/GRM-114 alignment and adjustments	5-7 5-112
	Component location diagrams	5-8 5-125
	Inspection	5-9 5-125
	Performance verification	5-10 5-125
	Disassembly instructions	5-11 5-125
	Reassembly instructions	5-12 5-166

		Paragraph	Page
CHAPTER 5.	Preparation for reshipment or limited storage	5-13	5-176
(Continued)	Demolition to prevent enemy use	5-14	5-176
CHAPTER 6.	SCHEMATIC DIAGRAMS		6-1
APPENDIX A.	REFERENCES		A-1
B.	COMPONENTS OF END ITEM LIST		B-1
c.	ADDITIONAL AUTHORIZATION LIST (Not Applicable)		
D.	MAINTENANCE ALLOCATION CHART		D-1
E.	EXPENDABLE SUPPLIES AND MATERIALS LIST (Not Applicable)		
F.	PINOUT TABLE FOR EXT ACC CONNECTOR		F-1

<http://www.pdf-tools.com>

## LIST OF ILLUSTRATIONS

Figure	Title	Page
1-1	Test set radio AN/GRM-114	1-0
2-1	AN/GRM-114 packaging	2-2
3-1	AN/GRM-114 general block diagram	3-2
3-2	Receive block diagram	3-3
3-3	Generate block diagram	3-6
3-4	Frequency error block diagram	3-7
3-5	1st local oscillator block diagram	3-9
3-6	2nd local oscillator block diagram	3-10
3-7	Dual tone generator block diagram	3-11
3-8	Oscilloscope block diagram	3-13
3-9	Spectrum analyzer circuit board 1 block diagram	3-15
3-10	Spectrum analyzer circuit board 2 block diagram	3-16
3-11	MM-100 (multimeter) block diagram	3-16
3-12	Power supply block diagram	3-18
4-1	AN/GRM-114 controls, indicators, and connectors	4-2
4-2	RF signal generator controls, indicators and connectors	4-15
4-3	Oscilloscope controls, indicators, and connectors	4-24
4-4	Receiver controls, indicators, and connectors	4-28
4-5	Spectrum analyzer controls, indicators, and connectors	4-37
4-6	Audio generator controls, indicators, and connectors	4-39
4-7	Frequency error measurement controls, indicators, and connectors	4-67
5-1	Flowchart symbol application	5-7
5-2	AN/GRM-114 performance test	5-8
5-3	Power supply troubleshooting	5-21
5-4	Audio frequency monitor troubleshooting	5-37
5-5	Receiver troubleshooting	5-44
5-6	Oscilloscope and spectrum analyzer troubleshooting	5-58
5-7	Frequency error measurement troubleshooting	5-68
5-8	RF signal generator troubleshooting	5-72
5-9	Dual tone generator - troubleshooting	5-91
5-10	RF wattmeter troubleshooting	5-94
5-11	TCXO and output distribution amplifier troubleshooting	5-98
5-12	MM-100 multimeter troubleshooting	5-102
5-13	Zero beat pattern	5-120
5-14	Front panel A1A1 (rear view) component location diagram	5-126
5-15	Mother board A1A2 component location diagram	5-127
5-16	Upper floor assemblies A1A3 component location diagram	5-128
5-17	Transmitter sensor A1A4 component location diagram	6-129
5-18	108 MHz bandpass filter A1A5 component location diagram	5-130
5-19	1200 MHz amplifier A1A6 component location diagram	5-130
5-20	Static discharge protector A1A7 component location diagram	5-190
5-21	Rear panel A1A8 component location diagram	5-131
5-22	Duty cycle regulator A1A8A1 component location diagram	5-132
5-23	High frequency phase-lock loop A1A9 component location diagram	5-132
5-24	79-80 MHz loop A1A10 component location diagram	5-133
5-25	VCO tuner A1A11 component location diagram	5-134
5-26	Dual tone generator AI AI 2 component location diagram	5-135
5-27	250 kHz I.F. monitor audio circuit board A1A13 component location diagram	5-136

## LIST OF ILLUSTRATIONS – Continued

Figure	Title	Page
5-28	Regulator and power supply A1A14 component location diagram	5-137
5-29	1080 MHz multiplier amplifier A1A15 component location diagram	5-138
5-30	1200 MHz diode switch A1A6 component location diagram	5-138
5-31	Power monitor A1A7 component location diagram	5-139
5-32	Spectrum analyzer A1A18 component location diagram	5-140
5-33	Spectrum analyzer module no. 1 A1A18A1 component location diagram	5-141
5-34	Spectrum analyzer module no. 2 A1A18A3 component location diagram	5-141
5-35	Oscilloscope main circuit board A1A18A4 component location diagram	5-142
5-36	1st mixer A1A19 component location diagram	5-143
5-37	2nd mixer A1A20 component location diagram	5-144
5-38	100 MHz filter A1A21 component location diagram	5-145
5-39	100 MHz amplifier/108 MHz mixer A1A24A1 component location diagram	5-145
5-40	120 MHz receiver A1A24A2 component location diagram	5-146
5-41	FM/AM generator A1A24A3 component location diagram	5-147
5-42	Relay driver A1A25 component location diagram	5-148
5-43	High level amplifier A1A28 component location diagram	5-148
5-44	High frequency multiplier/mixer A1A26 component location diagram	5-149
5-45	MM-100 assembly A2A1A1 component location diagram	5-150
5-46	AN/GRM-114 disassembly/reassembly diagram	5-179
5-47	Front panel disassembly/reassembly diagram	5-181
5-48	Upper floor disassembly/reassembly diagram	5-182
5-49	MM-100 multimeter disassembly/reassembly diagram	5-183
6-1	AN/GRM-114 mother board A1A2, schematic diagram (2 sheets)	6-3
6-2	AN/GRM-114 interconnect A1, schematic diagram (2 sheets)	6-7
6-3	AN/GRM-114 front panel assembly A1A1, schematic diagram (2 sheets)	6-11
6-4	AN/GRM-114 coaxial cable assembly A1A22, schematic diagram	6-15
6-5	AN/GRM-114 upper floor assembly A1A3, schematic diagram	6-17
6-6	Heterodyne amplifier, 2 prescaler A1A3A1, schematic diagram	6-19
6-7	1200-2200 MHz oscillator A1A3A2, schematic diagram	6-21
6-8	AGC system A1A3A3, schematic diagram	6-23
6-9	Clock divider A1A3A4, schematic diagram	6-25
6-10	TCXO output distribution amplifier A1A3A5, schematic diagram	6-27
6-11	Transmitter sensor A1A4, schematic diagram	6-29
6-12	108 MHz bandpass filter A1A5, schematic diagram	6-31
6-13	1200 MHz amplifier A1A6, schematic diagram	6-33
6-14	Static discharge protector A1A7, schematic diagram	6-35
6-15	Rear panel assembly A1A8, schematic diagram	6-37
6-16	Duty cycle regulator A1A8A1, schematic diagram	6-39
6-17	High frequency phase lock A1A9, schematic diagram	6-41
6-18	79-80 MHz loop A1A10, schematic diagram (2 sheets)	6-43
6-19	VCO tuner A1A11, schematic diagram	6-47
6-20	Dual tone generator A1A12, schematic diagram (2 sheets)	6-49
6-21	250 kHz i.f. monitor audio A1A13, schematic diagram (3 sheets)	6-53
6-22	Regulator and power supply A1A14, schematic diagram	6-59
6-23	1080 MHz multiplier amplifier A1A15, schematic diagram	6-61
6-24	1200 MHz diode switch A1A16, schematic diagram	6-63
6-25	Power monitor A1A17, schematic diagram	6-65
6-26	Spectrum analyzer A1A18, schematic diagram	6-67
6-27	Spectrum analyzer module no. 1 A1A18A1, schematic diagram	6-69
6-28	Oscilloscope inverter board A1A18A2, schematic diagram	6-71



## LIST OF ILLUSTRATIONS — Continued

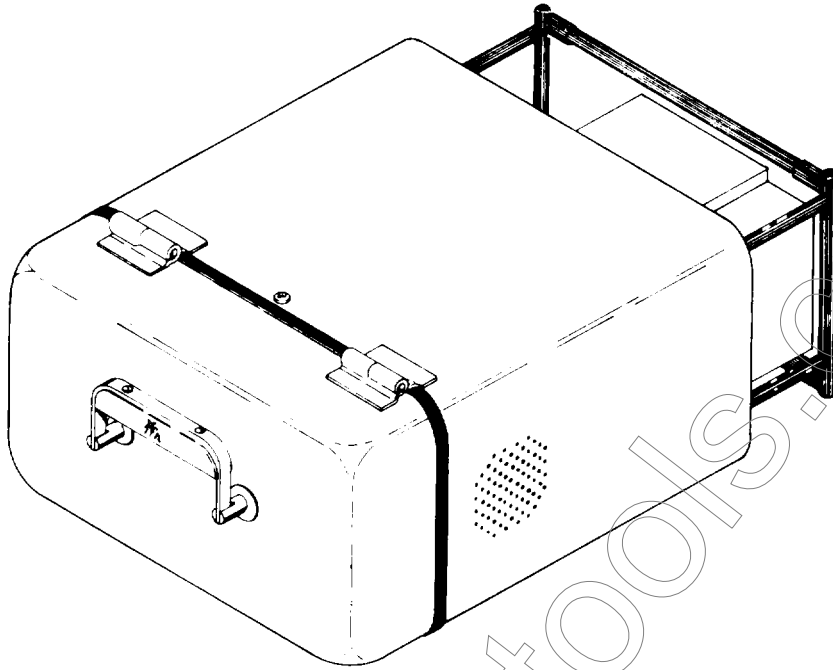
Figure	Title	Page
6-29	Spectrum analyzer module no. 2 A1A18A3, schematic diagram (3 sheets)	6-73
6-30	Oscilloscope main circuit board A1A18A4, schematic diagram (2 sheets)	6-79
6-31	Spectrum analyzer front plate assembly A1A18A5, schematic diagram	6-83
6-32	First mixer A1A19, schematic diagram	6-85
6-33	Second mixer A1A20, schematic diagram	6-87
6-34	100 MHz filter A1A21, schematic diagram	6-89
6-35	Battery, modified A1A23, schematic diagram	6-91
6-36	100 MHz amplifier/108 MHz mixer A1A24A1, schematic diagram	6-93
6-37	120 MHz receiver A1A24A2, schematic diagram (2 sheets)	6-95
6-38	FM/AM generator A1A24A3, schematic diagram	6-99
6-39	Relay driver A1A25, schematic diagram	6-101
6-40	High frequency multiplier/mixer A1A26, schematic diagram	6-103
6-41	Frequency select switch A1A27, schematic diagram	6-105
6-42	High level amplifier A1A28, schematic diagram	6-107
6-43	MM-100 assembly A2A1, schematic diagram (3 sheets)	6-109

## LIST OF TABLES

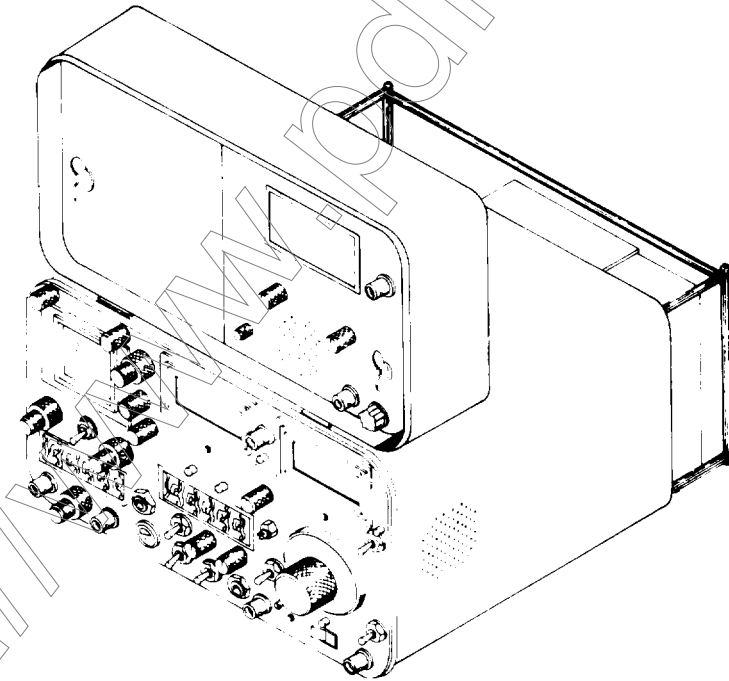
Number	Title	Page
1-1	Physical characteristics	1-2
1-2	Electrical characteristics	1-2
1-3	Environmental characteristics	1-6
1-4	Items supplied	1-6
4-1	AN/GRM-114 controls, indicators, and connectors	4-1
4-2	AN/GRM-114 operating instructions	4-13
4-3	RF signal generator initial adjustments and control settings	4-15
4-4	RF signal generator operating instructions	4-16
4-5	RF signal generator operating instructions for AM RF signals	4-18
4-6	RF signal generator operating instructions for FM RF signals	4-22
4-7	Oscilloscope initial adjustments and control settings	4-25
4-8	Oscilloscope operating procedures	4-25
4-9	Initial adjustments and control settings	4-29
4-10	Receiver operating instructions	4-29
4-11	Initial adjustments and control settings	4-38
4-12	Spectrum analyzer operating instructions	4-38
4-13	Spectrum analyzer operating instructions for spurious signal detection	4-43
4-14	Audio generator initial adjustment and control settings	4-49
4-15	Audio generation with MM-100 operating instructions	4-50
4-16	Audio generation with oscilloscope operating instructions	4-53
4-17	Power monitor operating instructions for measuring transmitter carrier power	4-58
4-18	Master oscillator calibration using received time standard signal	4-61
4-19	Master oscillator calibration using an external frequency standard	4-65
4-20	Initial adjustments and control settings	4-68

## LIST OF TABLES — Continued

Number	Title	Page
4-21	Frequency error measurement operating instructions	4-68
4-22	Multimeter operating instructions	4-71
5-1	Tools and test equipment	5-1
5-2	Glossary of abbreviations	5-4
5-3	AN/GRM-114 performance test - initial conditions	5-5
5-4	AN/GRM-114 performance test - initial conditions	5-6
5-5	Receiver troubleshooting - initial conditions	5-41
5-6	1st and 2nd local oscillators	5-41
5-7	Frequency error measurement - initial conditions	5-65
5-8	1st and 2nd local oscillates	5-65
5-9	RF signal generator troubleshooting initial conditions	5-71
5-10	AN/GRM-114 assemblies and interactive assemblies	5-112
5-11	VCO tuner adjustment	5-114
5-12	Tune pulse frequency and amplitude tests	5-116
5-13	Disassembly sequence	5-151



CASE CLOSED



CASE OPEN

Figure 1-1. Test Set Radio AN/GRM-114

## CHAPTER I INTRODUCTION

### Section I. GENERAL

#### 1-1. Scope.

a. This manual describes Test Set, Radio AN/GRM-114 and contains information for installation, operation, and direct support (DS), and general support (GS) maintenance.

b. Repair parts and special tools to support the AN/GRM-114 are listed in TM11-6625-3016-24P.

#### 1-2. Maintenance Forms, Records, and Reports.

a. Reports of Maintenance and Unsatisfactory Equipment. Department of the Army forms and procedures used for equipment maintenance will be those prescribed by TM 38-750, The Army Maintenance Management System.

b. Report Packaging and Handling Deficiencies. Fill out and forward SF 364 (Report of Discrepancy (ROD)) as prescribed in AR 735-11-2/DLAR 4140.55/NAVMATINST 4355.73/AFR 400.54/MCO 4430.3E.

c. Discrepancy in Shipment Report (DISREP) (SF 361). Fill out and forward Discrepancy in Shipment Report (DISREP) (SF 361) as prescribed in AR 55-38/NAVSUPINST 4610.33B/AFR 75-18/MCO P4610.19C/DLAR 4500.15.

1-3. Reporting Equipment Improvement Recommendations (EIR). If your AN/GRM-114 needs improvement, let us know, Send us an EIR. You, the user, are the only one who can tell us what you don't like about your equipment, Let us know why you don't like the design, Tell us why a procedure is hard to perform. Put it on an SF 368 (Quality Deficiency Report). Mail it to Commander, US Army Communications-Electronics Command, ATTN: DRSEL-ME-MQ, Fort Monmouth, New Jersey 07703, We'll send you, a reply,

1-4. Administrative Storage. Administrative storage of equipment issued to and used by Army activities will have preventive maintenance performed in accordance with the PMCS charts before storing. When removing the equipment from administrative storage, the PMCS should be performed to assure operational readiness. Disassembly and repacking of equipment for shipment or limited storage are covered in paragraph 5-7.

1-5. Destruction of Army Electronics Materiel. Destruction of Army electronics materiel to prevent enemy use shall be in accordance with TM 750-244-2.

### Section II. DESCRIPTION AND DATA

1-6. Purpose. Test Set, Radio, hereinafter referred to as Communications Service Monitor ANK2RM-114, or AN/GRM-114, (fig. 1-1) is a compact, light-weight, portable maintenance instrument which provides test and measurement capabilities to effectively test and service a variety of avionics and communications equipments.

1-7. Use. The AN/GRM-114 contains an internal rechargeable battery pack, and can be used almost anywhere without concern for immediate power. It can also be operated from an ac line voltage or an external dc source.

1-8. Description and Capabilities. The AN/GRM-114 incorporates the functions of an FM/AM signal generator, FM/AM receiver, RF spectrum analyzer, oscilloscope, audio generator, power monitor, and a multimeter. These functions permit the test set to perform general diagnostic tests end transmitter/receiver performance tests.

1-9. Equipment Characteristics, Table 1-1 lists the physical characteristics of the Communications Service Monitor AN/GRM-114. Table 1-2 lists the electrical characteristics, and table 1-3 lists the environmental characteristics.

Table 1-1. Physical Characteristics

Characteristics	Specification
Power:	110/230 V ac, 50 to 400 Hz or 11 to 28 V dc
Size:	12.5 in wide (31.8 cm), 8 in high (20.3 cm), 19.5 in deep (49.5 cm)
Weight:	Approximately 52 lb (22.4 kg)
Typical DC Currents:	4.3 A at 12 V and 1.85 A at 28 V (With oscilloscope/receiver ON and Dual Tone Generator/Spectrum Analyzer OFF)
Typical Power Consumption:	80 W
Internal Battery:	12 V dc 5.0 Ah

Table 1-2. Electrical Characteristics

Characteristics	Specification
RF Signal Generator	
Frequency Range:	100 Hz to 999.9999 MHz in 100-Hz steps
Frequency Accuracy:	5 x 10 <sup>-7</sup> (±0.00005%) 2 x 10 <sup>-7</sup> (typically) (See specification on TCXO Master Oscillator)
FM Quieting:	42 dB below 3.3 kHz deviation at 1-kHz rate, as measured in a 0.3 to 3-kHz post-detection bandwidth
Residual FM:	Less than 100 Hz
RF Output Power:	-130 dBm to -33 dBm (100 Hz-999.9999 MHz) -130 dBm to -∞ dBm (20 kHz-16 Hz) continuously variable into 50 W
Ranges:	NORM (Normal), μV x 100, and HI LVL (High Level) (0 dBm)
Accuracy:	-110 to -35 dBm ±2.5 dB to 400 MHz ±3.0 dB above 400 MHz These specifications may not be met at certain frequencies as a result of the internal design of the unit

Table 1-2. Electrical Characteristics – Continued

Characteristics	Specification
“HI Level” Power Range	0 dBm; $\pm 2.5$ dB (20 kHz to 600 MHz) $\pm 4.0$ dB (600 MHz to 999.9999 MHz) Dial indicator accuracy (dBm scale) is maintained relative to 0-dBm indication
Internal Modulation AM: FM:	10 Hz to 5 kHz (0 to 90%) 10 Hz to 9999.9 Hz rate, 0 to $\pm 15$ kHz deviation
External Modulation AM:  FM:	3.0 V ( $\pm 1$ V) peak-to-peak produces 90% modulation  6.0 V ( $\pm 2$ V) peak-to-peak produces $\pm 15$ kHz deviation (maximum modulating frequency = 15 kHz)
Oscilloscope Display Size: Vertical Bandwidth:  External Vertical Input Ranges: Horizontal Sweep Rate:	5 x 5 cm DC to 1 MHz (at 3-dB bandwidth) ac or dc inputs 10 mV, 100 mV, 1 V, 10 V per division 10 ms, 1 ms, 100 $\mu$ s, 10 $\mu$ s per division
Spectrum Analyzer  Dynamic Range:  Dispersion:  Bandwidth Resolution:	70 dB ( $-30$ dBm to $-100$ dBm)  Continuous from $\pm 0.5$ MHz to $\pm 5$ MHz from center frequency (1 to 10 MHz span)  30 kHz
Audio Generator  Frequency Range Variable Tone: Fixed Tone:  Accuracy Fixed Tone: Variable Tone: Resolution:  Output Level:	10.0 Hz to 9999.9 Hz 1 kHz  $\pm 20$ Hz 0.01% 0.1 Hz  0 to 2.9 V rms minimum for either tone into 150 W

Table 1-2. Electrical Characteristics – Continued

Characteristics	Specification
Distortion  10 Hz to 100 Hz: 100 Hz to 9999.9 Hz: Fixed Tone:	2% maximum 0.7% maximum 2% maximum
Receiver/Monitor	
Frequency Range: Resolution: 10 dB Sinad Sensitivity:	300 kHz to 999.9999 MHz 100 Hz 2 $\mu$ V (typical)
Selectivity at 3 dB Point	
Narrow:	Receiver 15 kHz; detector audio bandwidth is 8 kHz
Mid:	Receiver 150 kHz; detector audio bandwidth is 8 kHz
Wide:	Receiver 150 kHz; detector audio bandwidth is 80 kHz
Quieting:	Deviation measurements can be made down to 0.1 kHz
Adjacent Channel Rejection:	Greater than 25 dB at $\pm$ 25 kHz (typical)  Greater than 40 dB at $\pm$ 50 kHz (typical)
Beat Frequency Oscillator Accuracy:	BFO is phase-locked to master oscillator $\pm$ 3 dB, from 2 $\mu$ V to 5000 $\mu$ V
Demodulation Output Level	
AM:	100% = 0.5 V peak-to-peak nominal
FM:	$\pm$ 10 kHz = 0.65 V peak-to-peak nominal
Receiver Antenna Input Protection:	0.25 watts maximum level without damage
Power Monitor	
Frequency Range: Power Ranges:	1 MHz to 1 GHz 0 to 10 and 0 to 100 watts
Accuracy	
1 to 600 MHz: 600 MHz to 1 GHz:	$\pm$ 10% $\pm$ 20% of reading plus 3% of full scale
Input Power:	20 watts continuous; 100 watts for 10 seconds

Table 1-2. Electrical Characteristics – Continued

Characteristics	Specification
<p>TCXO Master Oscillator Accuracy:</p> <p>Aging Stability:</p> <p>Frequency Error Meter Measurement Capability</p> <p>Meter Sensitivity:</p> <p>Ranges:</p> <p>Resolution:</p> <p>Zeroing:</p>	<p><math>5 \times 10^{-7}</math> (<math>\pm 0.00005\%</math>), <math>2 \times 10^{-7}</math> (typical). Greater accuracy is attainable with front-panel adjustment</p> <p>2 to 3 ppm during first year; 1 ppm per year thereafter</p> <p>Typically <math>1.5 \mu\text{V}</math> above 1 MHz (sensitivity is reduced below 1 MHz)</p> <p><math>\pm 1.5 \text{ kHz}</math>, <math>\pm 5 \text{ kHz}</math>, <math>\pm 15 \text{ kHz}</math> (full scale)</p> <p>50 Hz (calibration marks at 100 Hz on <math>\pm 1.5\text{-kHz}</math> range)</p> <p>Frequency error meter is automatically zeroed every 1.5 seconds during a 3-ms time period. Auto zeroing may be disabled with AUTO/OFF/ZERO, BATT switch</p>
<p>MM-100 Multimeter</p> <p>SINAD</p> <p>Range: Accuracy:</p> <p>Distortion (DIST) Range:</p> <p><math>\pm</math>DC Volts Ranges: Accuracy:</p> <p>AC Volts Range: Accuracy:</p> <p>Selectable Impedances:</p>	<p>3-20 dB <math>\pm 1.5 \text{ dB}</math></p> <p>0-10%, and 0-30%</p> <p>.1V, .3V, 1V, 3V, 10V, 30V, 100V, and 300V (full scale)</p> <p><math>\pm 3\%</math> full scale (1 M <math>\text{W}</math> input Z)</p> <p>.1 to 300 V rms full scale</p> <p><math>\pm 3\%</math> full scale (25 Hz -25 kHz)</p> <p>3.2, 8, 150, and 600 W, and 1 M W unbalanced</p>



Table 1-2. Electrical Characteristics – Continued

Characteristics	Specifications
AM% Range:	0-100%
AC Load	HI-Z (1 M W)
Ohms	30 W center scale x 1
Fuse	1/32 A normal blow

Table 1-3. Environmental Characteristics

Characteristics	Specifications
Temperature Range	
Internal, Test Set	(32 to 122° F) 0 to 50° C

1-10. Items Supplied. Table 1-4 lists the items supplied.

1-11. Items Required (but not supplied). Items required that are not supplied are listed in table 5-1, Tools and Test Equipment.

Table 1-4. Items Supplied

Item	Quantity
AN/GRM-114 (includes multimeter MM-100)	1
Attenuator 10 dB Input 150 watts	1
10 dB attenuator	1
20 dB attenuator	1
30 dB attenuator	1
Cigarette lighter adapter plug DC power cord	1
Test probe for multimeter	1
Cable BNC on one end, N-type connector on other end	1
Antenna	1
90° BNC Connector	1

Table 1-4. Items Supplied - Continued

Item	Quantity
Spare fuses	4
1/32 A      250 V	1
1 1/4 A      125 V Slow Blow	1
7 1/2 A      32 V	2
Allen Wrench	1
Power cord AC	1
Canvas Cover/Carrying Case	1
Technical Manual TM 11-6625-3016-14	1

1-12. Warranty Information.

a. Warranty.

(1) IFR, Inc. warrants that each new instrument manufactured by it is free from defects in material or workmanship under normal use and service for a period of two years from the shipping date. (NOTE: 90 day warranty on battery pack). Each instrument is functionally tested immediately prior to shipment. If, upon examination by IFR, the instrument is determined to be defective in workmanship or material, IFR will, subject to the conditions set forth below, either repair the defective part or replace it with a new part on a pro rata basis. IFR shall not be liable for any delay or failure to furnish a replacement part resulting directly or indirectly from any governmental restriction, priority or allocation or any other governmental regulatory order or action, nor shall IFR be liable for damages by reason of the failure of the instrument to perform properly or for any consequential damages. The warranty does not apply to any instrument that has been subject to negligence, accident, shipping damage, misuse or improper installation or operation, or that in any way has been tampered with, altered or repaired by any person other than an authorized IFR service organization or any employee thereof, or to any instrument whose serial number has been altered, defaced or removed, or to any instrument purchased within, and thereafter removed beyond, the continental limits of the

United States. Annual recalibration is not included in warranty.

(2) All sales are FOB IFR Factory Wichita. IFR will assume responsibility for freight charges on all legitimate warranty claims within thirty (30) days from the original shipping date. All legitimate warranty claims within thirty (30) to ninety (90) days should be shipped to IFR freight collect and will be returned freight collect. All freight on warranty claims after ninety (90) days will be paid by the customer.

(3) This warranty shall, at IFR's option, become void if the equipment ownership is changed, unless the prior owner or the proposed owner obtains approval of continuation of the warranty prior to the change of ownership.

(4) This warranty is in lieu of all other warranties, expressed or implied, and no one is authorized to assume any liability on behalf of IFR or impose any obligation upon it in connection with the sale of any instrument, other than as stated above.

(5) The right is reserved to change the published specifications of the equipment at any time and to furnish merchandise in accordance with current specifications without incurring any liability to modify equipment previously sold, or to supply new equipment in accordance with earlier specifications except the classification of special apparatus.

b. Service.

(1) When requesting service, the originator shall give IFR information concerning the nature of the failure and the manner in which the equipment was used when the failure occurred. Type, model, and serial number should also be provided.

(2) Do not return any products to the factory without first receiving authorization from the factory Customer Service Department.

CONTACT: IFR, Inc.  
10200 W. York St.  
Wichita, Kansas 67215 USA  
ATTN: Customer Service Depart.  
PHONE: (800) 835-2350  
(Customer Service Only)  
TWX: 910-741-6952

(3) Unless otherwise specifically requested, packaging for a return shipment shall be in the original container and packaging material. If the original container and material are not available, information as to suitable packaging techniques will be provided by the IFR Shipping Department.

(4) Returned material claimed defective, but found to meet all previously applicable specifications, will be subject to a minimum evaluation charge consisting of the labor charges involved in the status determination of the material.

(5) Returned material not accompanied by statement of claimed defects may be returned at the originator's expense.

(6) All freight costs on non-warranty shipments are assumed by the customer.

(7) Any departure from the above instructions without specific factory authorization can be considered a breach of warranty, and all expenses incurred as a result will be billed to the originator.

1-13. Safety Precautions. Listed below are several important safety precautions which must be observed during all phases of installation and operation. IFR Inc. assumes no liability for customer's failure to comply with any of the safety precautions outlined in this manual.

a. Complying with Instructions. Installation/operating personnel should not attempt to install or operate AN/GRM-114 without reading and complying with all instructions contained in this manual. All procedures contained in this manual must be performed in exact sequence and manner described.

b. Grounding Requirements. To minimize shock hazard, chassis and case of AN/GRM-114 must be connected to an electrical ground. The unit is furnished with an ac and dc power cable, each of which incorporates a ground pin for this purpose. The ac power cable is equipped with a standard 3-pin grounded plug on one end which must be connected only to a properly grounded 3-pin wall receptacle.

**WARNING**

**Due to potential safety hazards, use of three-prong to two-prong adapter plug is not recommended.**

**The dc power cable features a cigarette lighter adapter on one end.**

**Operating Safety. Due to presence of potentially lethal voltages within AN/GRM-114, operating personnel must not remove test equipment covers at any time. Component replacement and internal adjustments must be made by qualified maintenance personnel only.**

**d. Observing CAUTION and WARNING Labels. Extreme care should be exercised when performing any operations preceded by a CAUTION or WARNING label. CAUTION labels appear where possibility of damage to equipment exists, while WARNING notes denote a condition where a shock hazard exists, exposing personnel to possible bodily injury.**

## CHAPTER 2

## PREPARATION FOR USE AND INSTALLATION

2-1. Unpacking. Refer to figure 2-1 and paragraph 1-2., c for AN/GRM-114 packaging.

- a. Position shipping carton with "OPEN THIS END" label facing up.
- b. Remove packing slip attached to top side of carton, (Use packing slip to confirm receipt of all goods as listed.)
- c. Cut and remove white holddown straps from shipping carton,
- d. Cut tape along top 3 edges of carton to open lid.
- e. Remove WARRANTY INFORMATION PACKET from carton.
- f. Remove top packing mold from carton.
- g. Unwrap polyethylene sheeting from top of canvas carrying case.
- h. Carefully lift canvas carrying case from carton by handle and remove polyethylene sheeting and bottom packing mold.
- i. Unzip carrying case and carefully remove AN/GRM-114.
- j. Save shipping carton and all packing material for possible reuse.

2-2. Assembly. The AN/GRM-114 comes fully assembled, except for the antenna. Refer to chapter 5, paragraph 7 for assembly instructions and drawings.

2-3. Checking Unpacked Equipment.

- a. Inspect all equipment for visible or concealed damage which may have occurred during shipment, If the equipment has been damaged, refer to "RECEIVING INSPECTION/UNPACKING" sticker af-

fixed to shipping container for "Damage Claim" procedure.

- b. Check the equipment and accessories against the packing slip. Report all discrepancies in accordance with the "Damage Claim" procedure.

2-4. Siting. The AN/GRM-114 may be battery operated in nearly any location, Mobile, aircraft, or marine operation is possible directly from 11- to 28- V dc power systems, using a furnished cigarette lighter adapter plug. AC operation is possible from 110/230-V ac, 50- to 400-Hz power sources.

2-5. Installation Instructions.

- a. Extend support bracket on bottom of unit to fully locked position and place the set on flat surface, bottom side down. (Bottom side of unit has four plastic feet.)
- b. Unlatch and fold back lid, exposing front panel face of unit. (If desired, lid can be detached from set at hinges by sliding lid to operator's right. )
- c. Remove retaining plate inside lid by rotating quick-release latch counterclockwise (ccw) and gently pulling plate straight out from lid.
- d. Remove ac and dc power cables from inside of lid, along with 90° BNC connector, Note additional accessories attached to rear side of retaining plate removed in step c. Those accessories include:

4 spare fuses  
1 antenna  
1 Allen wrench

(Refer to table 5-1 for list of items required but not supplied.)

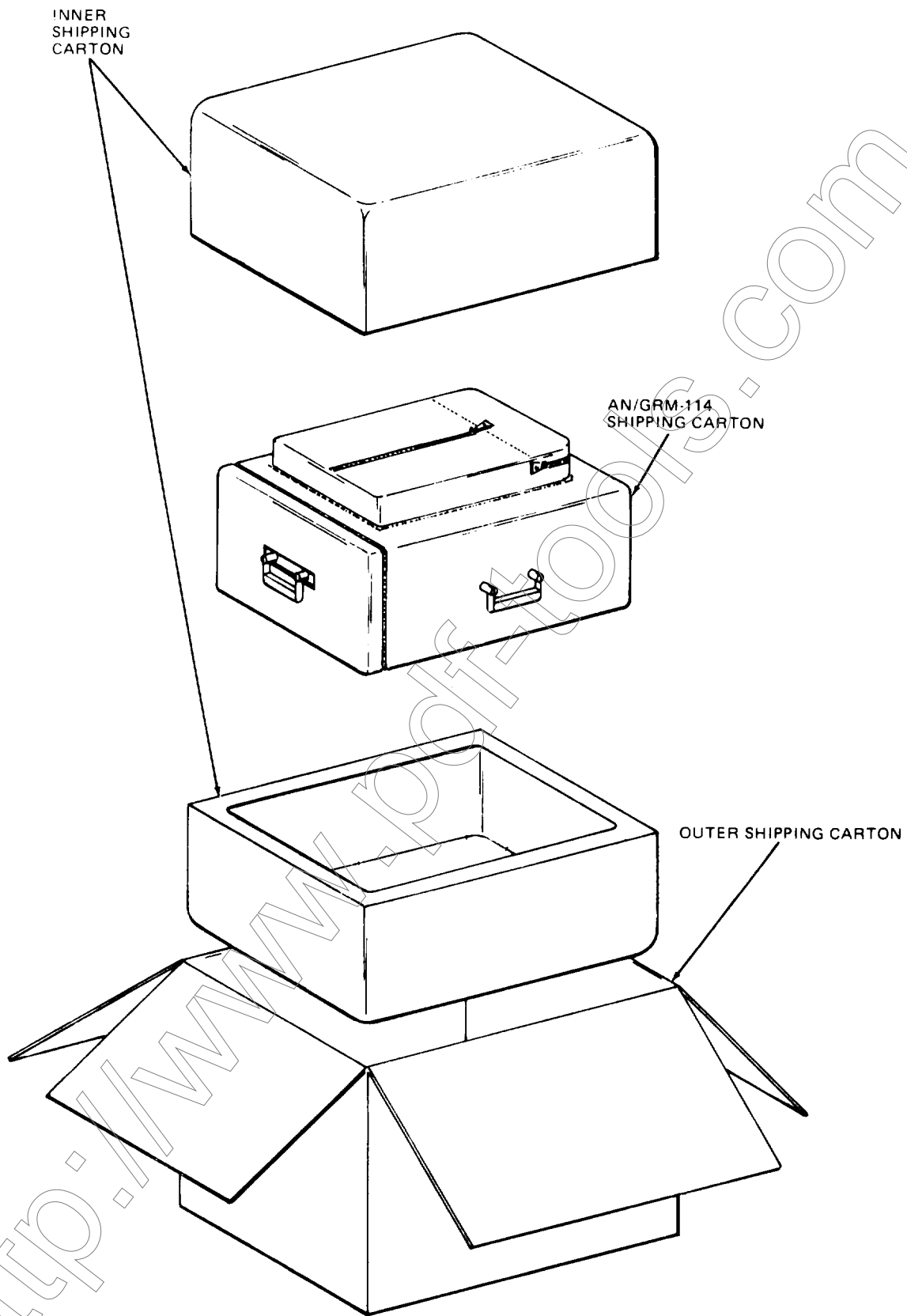


Figure 2-1. AN/GRM-114 packaging

- e. Determine source of power to be used to energize AN/GRM-114 and proceed accordingly:

(1) AC or DC Power

- (a) Connect 6-pin socket on end of furnished ac (or dc) power cable to 6-pin external power receptacle on rear of unit.
- (b) Connect 3-pin grounded plug on opposite end of ac power cable to standard 3-pin grounded receptacle. (For dc operation, connect cigarette lighter adapter on opposite end of dc power cable to cigarette lighter socket.)
- (c) Place PWR/OFF/BATT switch to PWR position to energize set.

(2) Battery Operation

- (a) No power cable connections required; place PWR/OFF/BATT switch to BATT position to energize unit.
- f. For "off-the-air" testing, antenna must be connected to ANT INPUT connector on front panel of unit. If unit is to be operated in an upright position, an antenna may be connected directly to ANT INPUT connector.

If unit is to rest on its support bracket during operation, attach antenna to furnished 90° BNC connector, then attach antenna/90° BNC connector assembly to ANT INPUT Connector.

**CAUTION**

If an external antenna attached to an unterminated coax cable is used, remove any possible static charge buildup before connecting coax to ANT INPUT connector.

2-6. Power Requirements. The AN/GRM-114 can be powered from its internal battery pack, or from ac or dc power sources. For ac operation, all units are normally factory wired to accept external power sources, which are generally available at the installation site.

**NOTE**

Before making any ac power connections, check the AN/GRM-114 power rating against the power source rating to insure that they are compatible. If they are not, refer to chapter 5, figure 5-3 for power supply modifications.

Power rating for the AN/GRM-114 can be found on the Model/Serial No. nameplate, which is located on the bottom side of the unit, or in chapter 1, paragraph 7, table 1-1.

An adhesive CAUTION sticker is on all units and power cables wired for operation at 230 V ac. No sticker is on units wired for operation at 110 V ac.

**CAUTION**

The AN/GRM-114 is designed to operate continuously with inputs of 20 W or less into the TRANS/RCVR connector. Should the input power to the AN/GRM-114 exceed 20 W, use the 10-dB, 150 W power attenuator supplied with the AN/GRM-114. Use of the 10-dB, 150 W attenuator will reduce the incoming power by a factor of 10. If the 10dB, 150 W attenuator is not available, the following chart must be observed:

100 W	10 sec. on 60 sec. off	15% duty cycle
50 W	20 sec. on 45 sec. off	30% duty cycle
30 W	2 min. on 2 min. off	50% duty cycle

**CAUTION**

If the AN/GRM-114 is being powered by a vehicular dc supply, unplug the AN/GRM-114 before starting the engine.

2-7. Initial Checks and Alignment. If an external power source is used, either ac, or dc using the cigarette lighter adapter, ensure that the power cable is securely mated to the ac plug on the outside of the AN/GRM-114 rear panel.

<http://www.pdf-tools.com>

## CHAPTER 3

## THEORY OF OPERATION

## NOTE

The schematics referenced in this chapter are located in Chapter 6.

3-1. General Theory. (Refer to Figure 3-1 for a block diagram. )

The AN/GRM-114 Communications Service Monitor is a highly accurate, versatile, portable unit which may be used to monitor, align, and troubleshoot CW, AM, FM and SSB Communications equipment. The unit features a quadruple-conversion digitally-synthesized superheterodyne receiver and a dual-conversion digitally-synthesized low-power rf signal generator. The unit also contains a variable-frequency tone generator and a fixed-frequency tone generator (refer to paragraph 3-7), spectrum analyzer, multimeter (refer to paragraph 3-10) an oscilloscope (refer to paragraph 3-8) and an rf wattmeter. The AN/GRM-114 may be powered (refer to paragraph 3-11) by an external source of 115 or 230 V ac; 11 to 28 V dc, or by the internal 12 volt rechargeable lead-acid battery. The internal battery is kept charged by means of an internal cur-rent regulated charger circuit. The charger circuit is energized whenever the AN/GRM-114 ac power cord is connected to an active ac outlet. The charger circuit is energized even when the AN/GRM-114 is turned off. The internal battery may be charged by applying 14 to 16 V dc from an external source to pin 11 of the rear panel power jack. The negative terminal of the external source should be connected to pin 10 of the rear panel power jack.

a. Used as a receiver (refer to paragraph 3-2), the AN/GRM-114 permits the technician to monitor and measure the characteristics of CW, AM, FM and SSB signals from 300.0 kHz to 999.9999 MHz. The FREQUENCY MHz thumbswitches on the front panel control the digital frequency synthesis circuitry (refer to paragraphs 3-5 and 3-6) which tunes the receiver to the selected frequency. The AN/GRM-114 receiver frequency is specified as accurate to within .00005% of the selected frequency. Typically, it is accurate

to within .00002%. The 10 MHz TCXO (Master oscillator) is principally responsible for maintaining receiver frequency accuracy and stability. The demodulated outputs of the receiver may be used to audibly monitor an applied signal, determine its relative signal strength, exact carrier or resting frequency, and modulation characteristics. An Intermediate Frequency (IF) representation of the received signal may be displayed on the Spectrum Analyzer, (refer to paragraph 3-9) where amplitude, bandwidth and spectral purity may be measured and examined.

b. The AN/GRM-114 AM/FM rf signal generator (refer to paragraph 3-3) permits the technician to inject low power CW, AM or FM signals from 100 Hz to 999.9999 MHz into a unit under test (JUT). The FREQUENCY MHz thumbswitches on the front panel control the digital frequency synthesis circuitry which sets the generator to the selected frequency. The AN/GRM-114 rf signal generator frequently is specified as accurate to within .00005% of the selected frequency. Typically it is accurate to within .00002%. The TCXO is principally responsible for maintaining generator frequency accuracy and stability. The rf signal generator may be AM or FM modulated by using the internal Dual Tone Generator and/or an external audio signal applied to the EXT MOD jack on the front panel. FM deviation and depth of AM modulation may be set by adjusting the amplitude of the modulating signal (s). The amount of FM deviation may be read on the DEVIATION (KHz) /WATTS meter (refer to paragraph 3-4) and/or displayed on the oscilloscope. The percentage of AM modulation may be determined by displaying the AM modulation envelope on the oscilloscope and/or by using the AM% modulation function of the Multimeter (MM-100).

3-2. Receive Theory. (Refer to figure 3-2 for a block diagram.)

a. Antenna input is received at the ANT INPUT connector and passes through the Static Discharge Protector which limits voltage and cur-



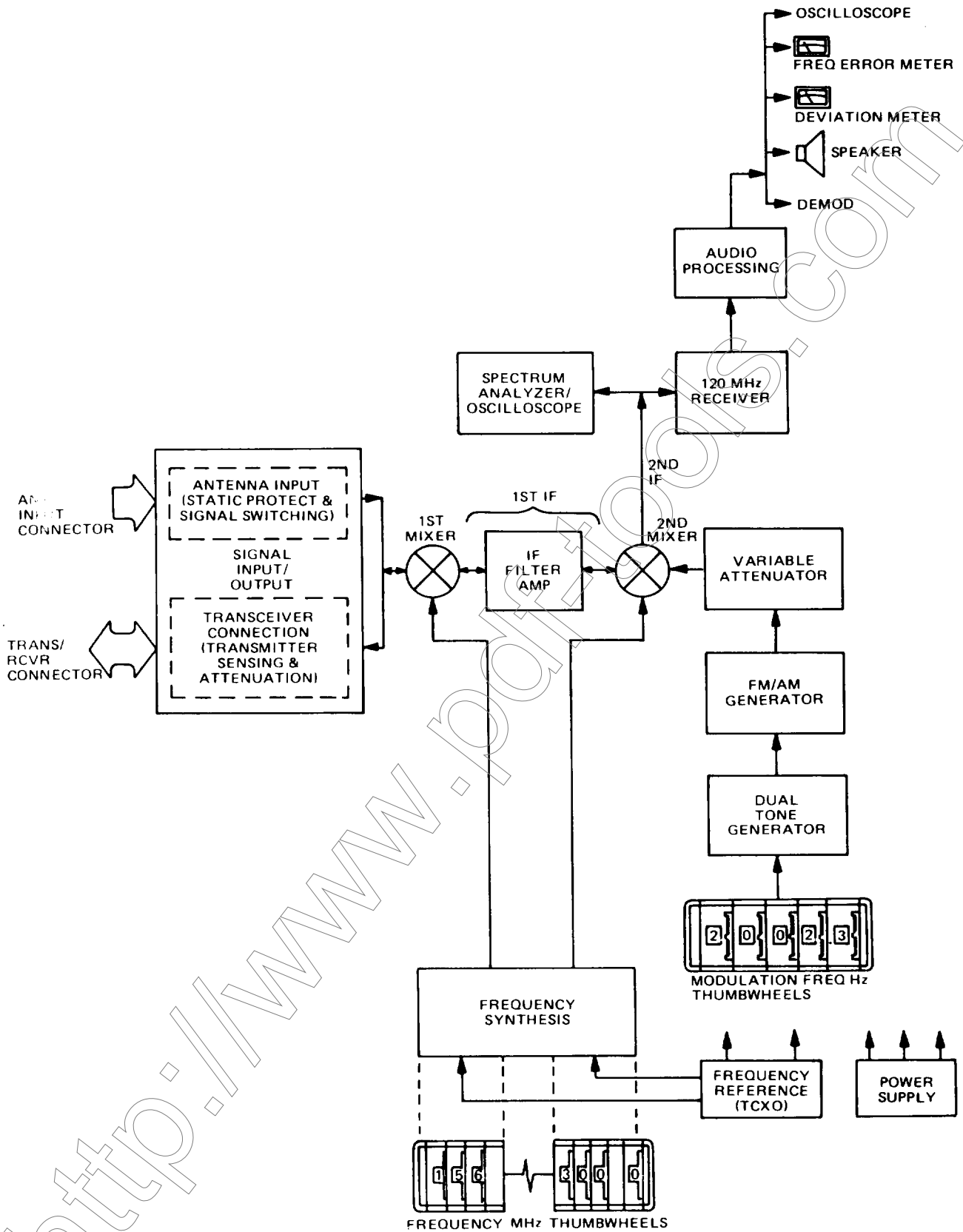


Figure 3-1. AN/GRM-114 block diagram

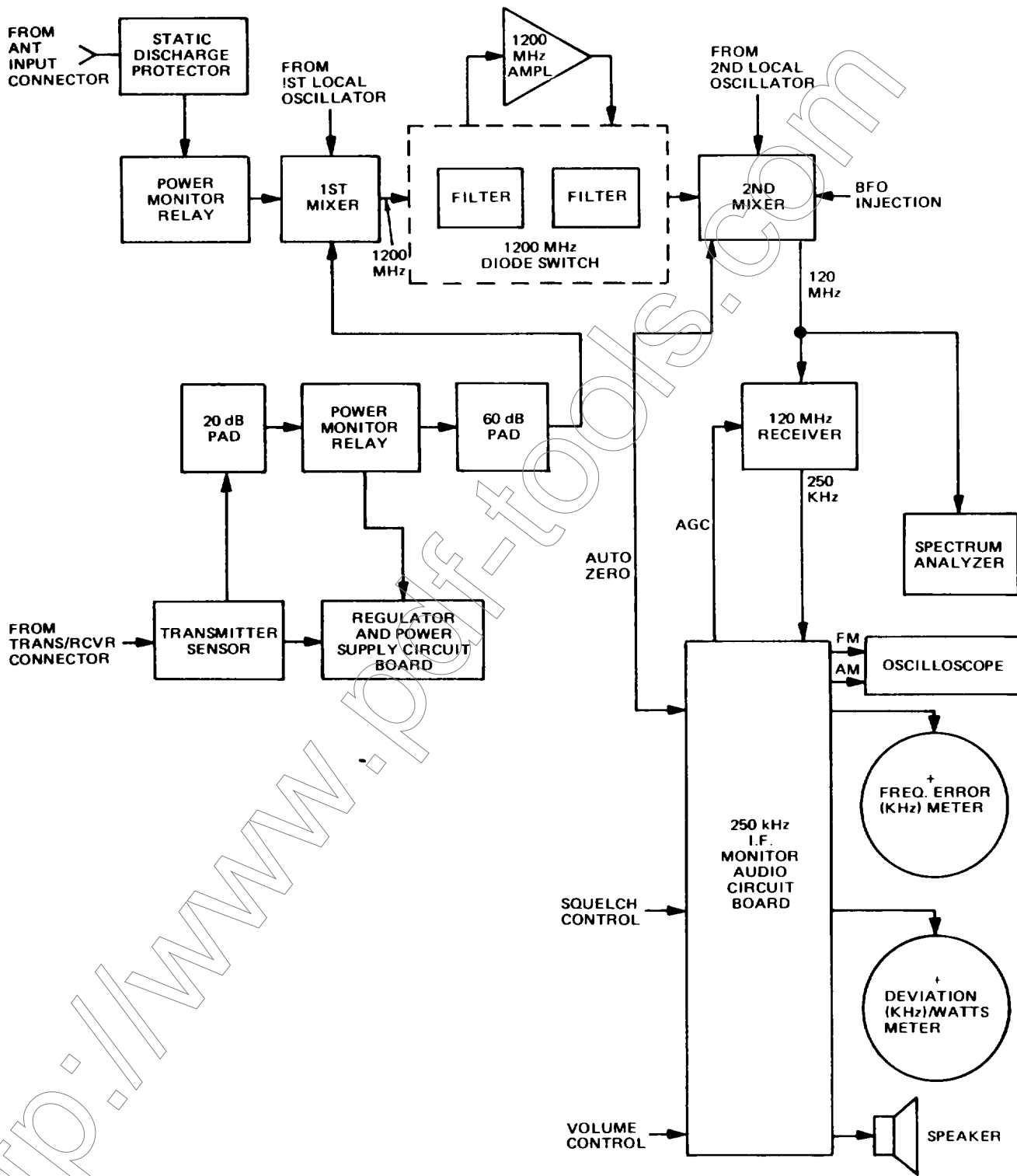


Figure 3-2. Receive block diagram

rent to protect the 1st Mixer (figure 6-32). The Power Monitor Relays (figure 6-25) are de-energized. The 1st Mixer Relays (figure 6-32) are de-energized and the 1st local oscillator signal (refer to figure 3-5 for a block diagram) is present at 1200-MHz above the first three digits of the FREQUENCY MHz thumbwheels. A 1200-MHz intermediate frequency is applied to the 1200-MHz Diode Switch (figure 6-24), where it is filtered. It is then applied to the 1200-MHz Amplifier, and the amplified signal is applied to the 1200-MHz Diode Switch where it is filtered once more. The 1200-MHz signal is applied to the 2nd Mixer (figure 6-33), where the 2nd local oscillator signal (refer to figure 3-6 for a block diagram) is present at 1079.0001-1080.000-MHz, depending on the last four digits of the FREQUENCY MHz thumbwheels. The 2nd Mixer beats the two signals together and the difference signal of 120-MHz is fed through the Receive Diode Switch to the Spectrum Analyzer for display and to the 120-MHz Receiver (figure 6-37). Within the 120-MHz Receiver, the 120-MHz signal beats with a signal from a 109.3-MHz oscillator. The difference signal of 10.7-MHz beats with a signal from a 10.95-MHz oscillator, and the 250-kHz difference signal is applied to the 250-kHz I.F. Monitor Audio Circuit Board (figure 6-21). The signal splits for AM and FM demodulation. AM audio and signal level are detected. The detected signal level operates the AGC and squelch systems. The AGC System controls the gain from the 120-MHz Receiver to the 250-kHz I.F. Monitor Audio Circuit Board. The SQUELCH adjustment controls the squelch threshold, which is the signal level required at the ANT INPUT connector for audio output to be enabled, and the detected signal level is applied to the DEVIATION (KHz)/WATTS meter to display the signal strength. A 250-kHz Intermediate Frequency (I. F.) is applied to the oscilloscope for display of the AM envelope. The 250-kHz I.F. is rectified to a dc level through a discriminator and audio filter. The dc level is the reference for the FREQ. ERROR (KHz) meter. If the I.F. signal increases, the dc level increases moving the FREQ. ERROR (KHz) Meter in the positive direction. If the I.F. signal decreases, the dc level decreases, moving the FREQ. ERROR (KHz) /watts meter in the negative direction. The amount of change in the Intermediate Frequency as it increases or decreases due to modulation is the FM deviation. The rate of change as the Intermediate Frequency increases or decreases is the FM audio signal. This signal is sent

to the oscilloscope for monitoring FM deviation and frequency. This signal is also applied to a peak detector to operate the DEVIATION (KHz)/WATTS meter. A separate FM audio output goes to the FM contact of the AM/FM switch. The AM audio output goes to the AM position of the AM/FM switch. The output of the AM/FM switch is the Demod output of the test set. This output is fed to the MM 100 and RCVR contact of the INT MOD/RCVR switch. The output of the INT MOD/RCVR switch passes through the volume control to the audio amp and out to the speaker.

b. Transmitter input is applied at the TRANS/RCVR connector on the front panel. The Transmitter Sensor (figure 6-11) puts the unit into the Receive mode if the GEN/RCVR switch is in the GEN position. The signal is attenuated by a 20 dB pad. The output signal is applied to the Power Monitor relays. The relays are de-energized, the signal passes through the relays, and is detected by the Power Monitor diode. The detected signal is applied to the Regulator and Power Supply Circuit Board (figure 6-22), where it operates the Power Monitor functions on the circuit board. The circuit board sends a signal to the Relay Driver (figure 6-39) to energize the 1st Mixer relays. The applied signal passes through a 60-dB attenuator to the 1st Mixer relay assembly. The signal applied at the TRANS/RCVR connector is therefore attenuated by a total of 80 dB. For example, if 100 watts is applied to the TRANS/RCVR connector, -30 dBm is applied to the 1st Mixer relay assembly. The relays are energized, and pass the signal to the 1st Mixer circuit. From there, the signal follows the same path described in paragraph 3-2a.

3-3. Generate Theory, ( Refer to figure 3-3 for a block diagram. )

a. The 120-MHz FM/AM Generator always generates a 120-MHz signal. This signal is phase locked to the TCXO through a .10-kHz signal from the Clock Divider (figure 6-9). The Dual Tone Generator (figure 6-20) sends an audio signal to the FM/AM Generator applying either AM or FM modulation to the 120-MHz signal, depending on the position of the AM/FM switch. This modulated 120-MHz signal is crossed to the 2nd Mixer (figure 6-33). The crossfeed diode switch in the 2nd Mixer allows a signal path through the 2nd Mixer to the 120-MHz Receiver and the Spectrum Analy -

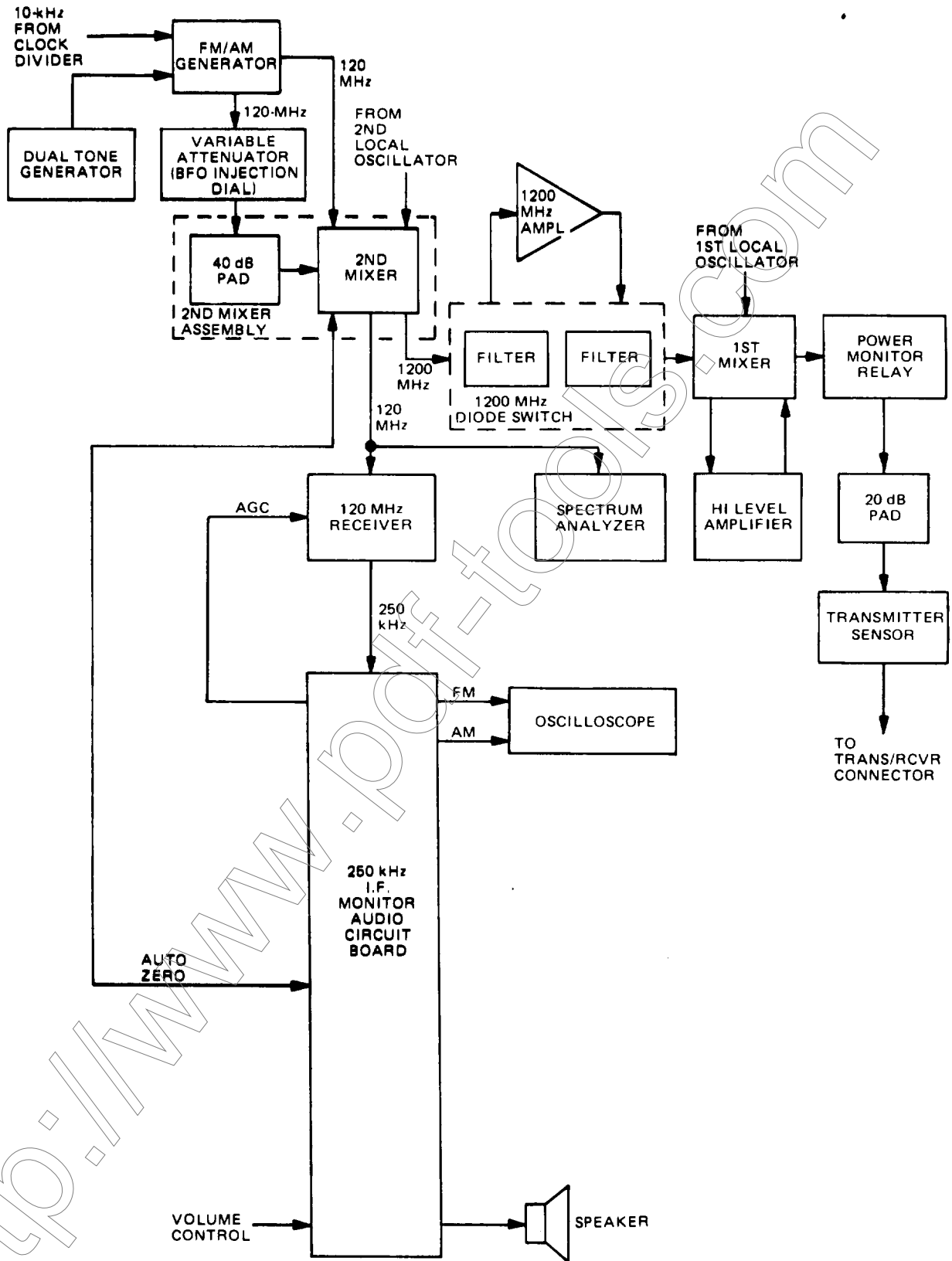


Figure 3-3. Generate block diagram

zer. From there, it follows the same path through the 120-MHz Receiver (figure 6-37) and the 250-kHz I.F. Monitor Audio Circuit Board (figure 6-21) as do received signals (refer to paragraph 3-2a.). A second 120-MHz output of the FM/AM Generator is applied to the variable attenuator (RF LEVEL/BFO INJECTION), which is calibrated in both  $\mu\text{V}$  and dBm. The variable attenuator is accurate at the TRANS/RCVR port with a scaling factor which is controlled by the HI LVL/ $\mu\text{V} \times 100/\text{NORM}$  switch. Attenuator output is applied to the 2nd Mixer where it can be attenuated by a 40-dB pad, depending on the position of the HI LVL/ $\mu\text{V} \times 100/\text{NORM}$  switch. If the switch is in the NORM position, the 40-dB pad is selected. It is bypassed if the switch is in the  $\mu\text{V} \times 100$  or III LVL position. The generate diode switch applies a 120-MHz signal to the 2nd Mixer. The 2nd Local Oscillator (refer to Figure 3-6 for a block diagram ) output mixes with the 120-MHz generated signal producing a frequency of approximately 1200-MHz. The 1200-MHz I.F. is fed to the 1200-MHz Diode Switch (figure 6-24) where it is filtered, applied to the 1200-MHz Amplifier (figure 6-13) and returned to a second filter in the 1200-MHz Diode Switch. From there the 1200-MHz signal is fed to the 1st Mixer where it mixes with the output of the 1st Local Oscillator. The output of the 1st local oscillator is 1200-MHz above the setting of the three leftmost digits of the FREQUENCY MHz thumbwheels. The 1st Mixer relays are de-energized, and the signal passes through to the Power Monitor Relays (figure 6-25). The relays are energized, and the signal passes to the 20 dB pad and the Transmitter Sensor (figure 6-11 ). The signal is then applied to the TRANS/RCVR connector.

b. When the HI LVL/ $\mu\text{V} \times 100/\text{NORM}$  switch is in the HI LVL position, power is applied to the High Level Amplifier (figure 6-42). The signal path up to the 1st Mixer is the same as for generate operation (refer to paragraph 3-3a). The 1st Mixer relays energize, and the signal goes from the 1st Mixer circuit to the High Level Amplifier. Amplified output is sent back to the 1st Mixer Assembly and through the relays. It then follows the path through the Power Monitor relays, the 20 dB pad, and the Transmitter Sensor to the TRANS/RCVR connector as in generate operation (refer to paragraph 3-3a).

c. The beat frequency oscillator (BFO) is active only when the GEN/RCVR switch is in the

RCVR position. When the BFO/OFF switch is in the BFO position, the FM/AM generator generates a 120-MHz signal. The signal is applied to the 2nd Mixer through the variable attenuator (RF LEVEL/BFO INJECTION). If the HI LVL/ $\mu\text{V} \times 100/\text{NORM}$  switch is in the NORM position, the 40 dB pad in the 2nd Mixer is selected. It is bypassed if the switch is in the  $\mu\text{V} \times 100$  position. The BFO coupling mixes the generated signal with the received signal. The signal then follows the path out of the 2nd Mixer described in paragraph 3-2a.

3-4. Frequency Error Theory. (Refer to figure 3-4 for a block diagram. )

a. The AUTO/OFF/ZERO, BATT switch must be in the AUTO ZERO position (upper position) in order for Frequency Error Measurements to be taken. When it is in the AUTO ZERO position, errors caused by drift of the 109.3 MHz crystal oscillator (3rd local oscillator) or the 10.95 MHz crystal oscillator (4th local oscillator) in the 120-MHz Receiver (figure 6-37) and offset errors in the 250 kHz I.F. Monitor Audio Circuit Board (figure 6-21 ) are corrected. These corrections are made at the Frequency Error Meter Driver on the 250 kHz I.F. Monitor Audio Circuit Board. When the AUTO/OFF/ZERO, BATT switch is in the AUTO position, an auto zero pulse is produced every 1.5 seconds, with a 3-ms "on time". This pulse is applied to the 250 kHz I.F. Monitor Audio Circuit Board and 2nd Mixer (figure 6-33). This pulse turns off the 2nd Mixer Receive Diode Switch, the Generate Diode Switch, the Generate Crossfeed Diode Switch and turns on the Auto Zero Diode Switch. It also disables the AGC system in the 250 kHz I.F. Monitor Audio Circuit Board. The 10-MHz input to the 2nd Mixer Diode Switch Assembly from the TCXO Output Distribution Amplifier (figure 6-10) is multiplied to 120 MHz. The Auto Zero Diode Switch feeds this 120-MHz signal to the 120 MHz Receiver and Spectrum Analyzer. The 120-MHz Auto Zero signal is mixed in the 120-MHz Receiver with a signal from the 109.3 MHz crystal oscillator (3rd local oscillator). The difference signal of approximately 10.7-MHz is mixed with a signal from a 10.95 MHz crystal oscillator. The difference signal, which incorporates errors due to drift of the 3rd and 4th local oscillators, is approximately 250 kHz. This signal is fed to the discriminator and the Frequency Error Meter Driver Circuit on the 250-kHz I.F. Monitor Audio Circuit Board. During the AUTO ZERO pulse, the output of the Frequency Error

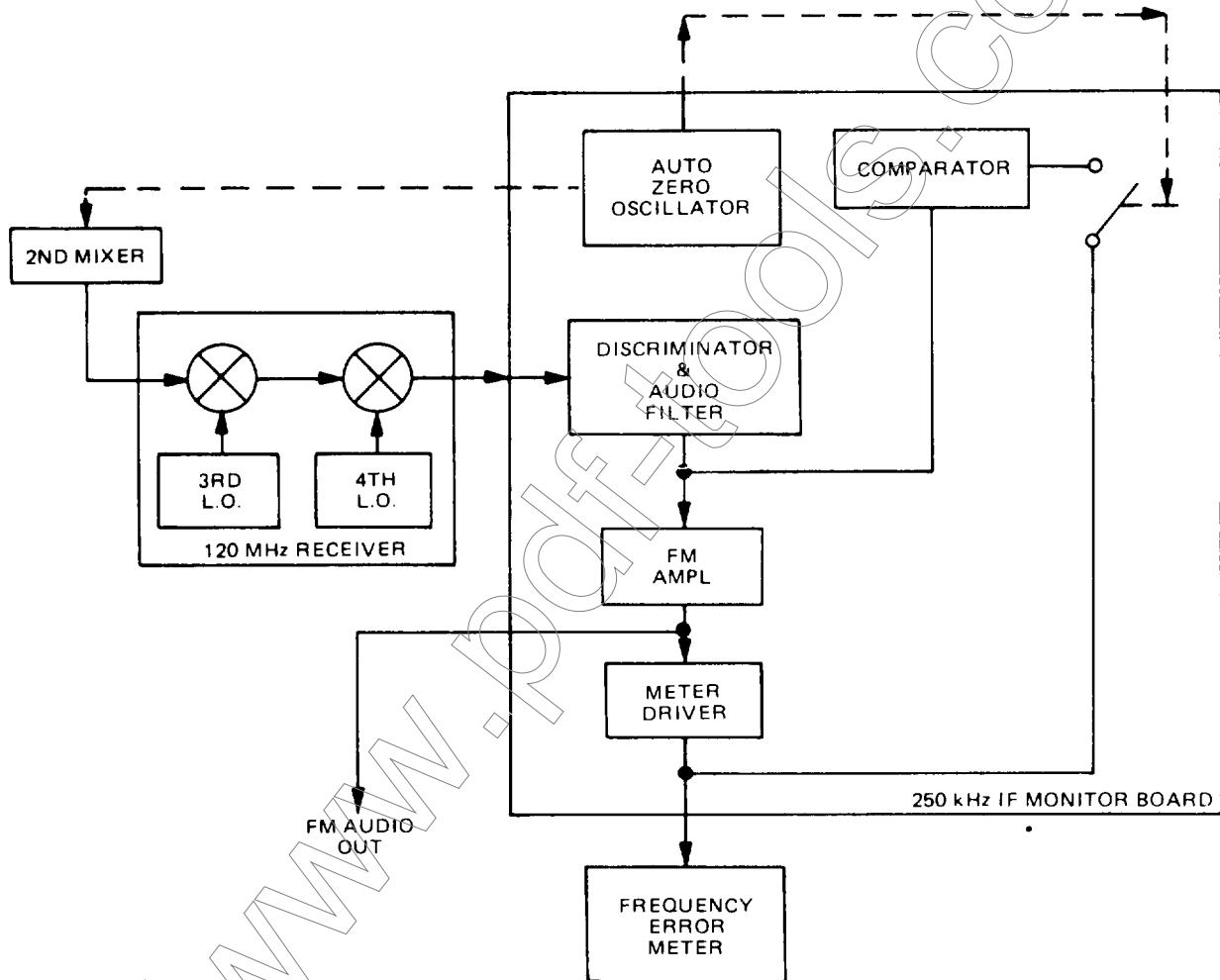


Figure 3-4. Frequency error, block diagram

Meter Driver Circuit is fed to a comparator, The output of the comparator sums with the output of the discriminator. This sum signal zeroes the Frequency Error Meter Driver output of the comparator and the **FREQ. ERROR (KHz)** meter. After the **AUTO ZERO** pulse, there is a 0.5 ms delay until the meter circuits are activated. This gives the system time to reestablish the original signal.

3-5. 1st Local Oscillator Theory. (Refer to figure 3-5 for a block diagram, )

The TCXO applies a 10-MHz signal to the 100-MHz Amplifier/108-MHz Mixer (figure 6-36) through the TCXO Output Distribution Amplifier (figure 6-10). The 100-MHz Amplifier/108-MHz Mixer selects the fifth harmonic of 10-MHz, amplifies it and multiplies the 50-MHz signal by two. The resulting 100-MHz signal is amplified and applied to the 100-MHz Filter (figure 6-34). The 100-MHz signal is then applied to the High Frequency Multiplier/Mixer (figure 6-40), where it is amplified, then applied to the five tuned cavities within the High Frequency Multiplier/Mixer. The outputs of the tuned cavities are selected by the VCO Tuner (figure 6-19), which is controlled by the leftmost digit of the **FREQUENCY MHz** thumbwheels (figure 6-41). The value of the leftmost digit also selects the frequency range of the 1200-2200-MHz Oscillator (figure 6-7) through the VCO Tuner. If the digit is 0 or 1, the 1100-MHz cavity is selected, and the 1200-2200-MHz Oscillator is 1200-1399-MHz, If it is 2 or 3, the 1300-MHz cavity is selected, and the Oscillator is 1400 -1599-MHz, If the digit is 4 or 5, the 1600-MHz cavity and the 1600-1799-MHz range are selected, The 1700-MHz cavity and the 1800-1999-MHz range are selected when the digit is 6 or 7. The 1900-MHz cavity and the 2000-2199-MHz range are selected if the digit is 8 or 9. The 1200-2200-MHz Oscillator applies its selected frequency to the High Frequency Mutliplier/Mixer, where it is mixed with the frequency of the selected tuned cavity to produce a signal from 100 to 299-MHz. This signal is applied to the Heterodyne Amplifier ,2 Prescaler (figure 6-6), which divides it into an output signal between 50 and 149.5-MHz. This signal is applied to the High Frequency Phase Lock (figure 6-17), and is divided in a programmable divider circuit by a number between 100 and 299, which is selected by the first three digits (100, 10 and 1-MHz) of the **FREQUENCY MHz** thumbwheels. The resulting frequency provides one input to the phase detector

circuit. The TCXO, through the TCXO Output Distribution Amplifier, applies a 10-MHz signal to the reference circuit of the High Frequency Phase Lock. This 10-MHz signal is divided by twenty, and provides a 500-kHz reference for the phase detector. If a frequency/phase difference is detected between the programmable divider circuit and the 500-kHz reference, the resultant difference signal (a dc level) is applied to the VCO Tuner which in turn slews the 1200-2200 MHz VCO frequency as necessary until the output of the programmable divider settles at 500-kHz. At this point, the High Frequency Phase lock loop is locked on frequency (High Frequency Multiplier/Mixer, Heterodyne Amplifier ,2 Prescaler, High Frequency Phase Lock, VCO Tuner, and 1200-2200-MHz Oscillator). The VCO Tuner also applies a fast tune line to the AGC System (figure 6-8), which applies it to the 1200-2200-MHz Oscillator to provide controlled gain of the loop at the selected frequency. The 1200-2200-MHz Oscillator applies a signal, which is the output of the 1st local oscillator, to the 1st Mixer (figure 6-32). An indication that the High Frequency Phase Lock loop is operating properly is that the left lock lamp is lit.

3-6. 2nd Local Oscillator Theory. (Refer to figure 3-6 for a block diagram.)

The TXCO sends a 10-MHz signal through the TCXO Output Distribution Amplifier (figure 6-10) to the Clock Divider (figure 6-9). The Clock Divider reduces the signal to 100-Hz and applies it to the 79-80 MHz Loop (figure 6-18). The value of the four rightmost digits of the **FREQUENCY MHz** thumbwheels determine the output of the 79-80 MHz Loop, The frequency varies from 7.90001-MHz if the digits are 9999 to 8.00000. MHz if the digits are 0000, When the 79-80 MHz Loop is operating properly, the right lock lamp on the front panel will be lit. The output frequency is applied to the 100-MHz Amplifier/108-MHz Mixer (figure 6-36), which mixes the signal with 100-MHz. The output signal, which is between 107.90001 - MHz and 108.00000-MHz, is applied to the 108-MHz Bandpass Filter (figure 6-12), then to the 108 O-MHz Multiplier Amplifier (figure 6-23), where it is multiplied by ten. The resulting signal 1079.0001-MHz to 1080.0000-MHz, is the output of the 2nd local oscillator. It is applied to 2nd Mixer (figure 6-33).

3-7. Dual Tone Generator Theory. (Refer to figure 3-7 for a block diagram. )

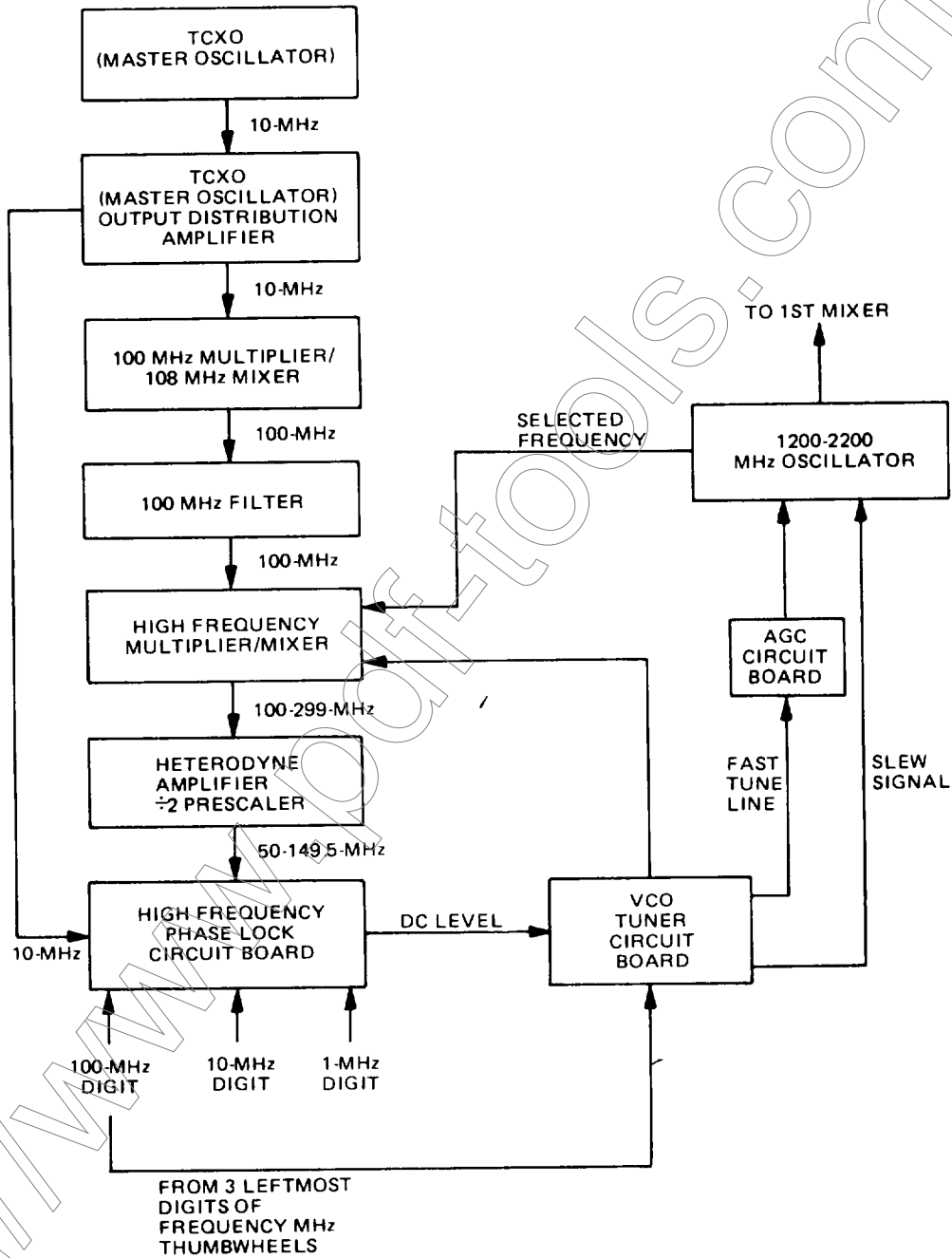


Figure 3-5. 1st local oscillator block diagram



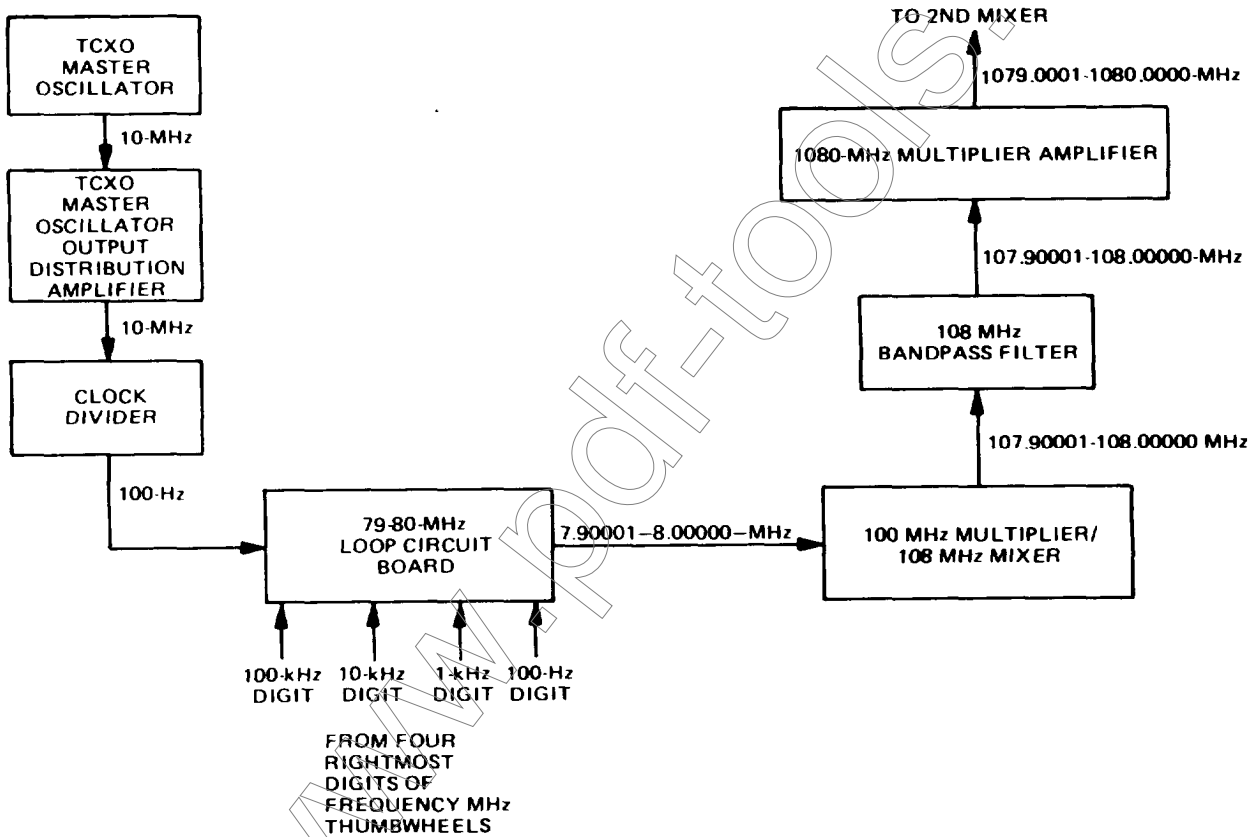


Figure 3-6. 2nd local oscillator block diagram

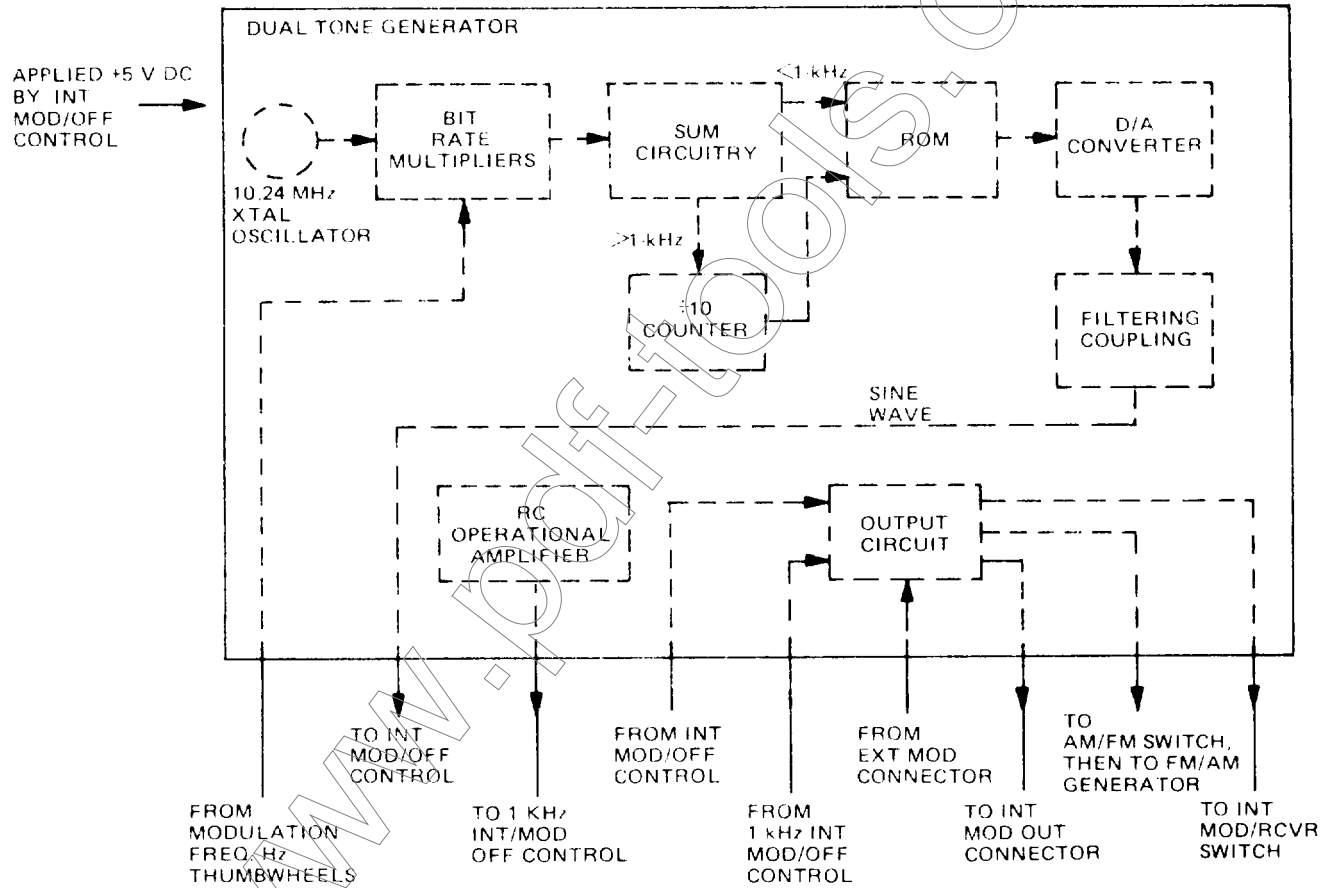


Figure 3-7. Dual tone generator block diagram

a. The INT MOD/OFF control applies power (+5 V dc) to the variable tone circuits. The MODULATION FREQ. Hz thumbwheels control the frequency, which is digitally selected, and crystal controlled. The output of a 10.24 MHz crystal oscillator is applied to bit rate multipliers which are controlled by the setting of the MODULATION FREQ. Hz thumbwheels. The output of the bit rate multipliers is summed. If it is greater than 1-kHz, it is sent to a 10 counter, then to a Read Only Memory (ROM). If it is less than 1-kHz, it is sent directly to the ROM. It is then applied to a Digital/Analog (D/A) converter, where it is converted to a frequency based on output from the ROM. The output signal from the D/A converter is filtered and ac coupled into a sine wave. This signal is applied to the INT MOD/OFF control on the front panel. The INT MOD/OFF control potentiometer (POT) varies the output level. The tone generator can be keyed off by inserting a phone jack into the EXT MOD connector.

b. The fixed tone generator is a resistor capacitor (RC) operational amplifier oscillator which adjusts the frequency to approximately 1 kHz. The signal is applied to the 1-kHz INT MOD/OFF control, which controls the amplitude.

c. If there is an external modulation input at the EXT MOD connector, it is presented for summation in the Dual Tone Generator Assembly (figure 6-20).

d. In the output circuit of the Dual Tone Generator, the fixed tone, the variable tone, and input at the EXT MOD connector are summed. The summed signal is applied to an output buffer-amplifier. The amplified signal is applied to the INT MOD OUT connector, to the AM/FM switch, which applies it to the FM/AM Generator (figure 6-38), and to the INT MOD position of the INT MOD/RCVR switch. This switch couples the signal to the VOL control, and the VOL control feeds the 250-kHz I.F. Monitor Audio Circuit Board (figure 6-21), which applies an audio signal to the speaker.

3-8. Oscilloscope Theory, (Refer to figure 3-8 for a block diagram.)

a. To operate the oscilloscope, the ANALY DISPR control must be turned fully ccw, in detent. When the control is in this position, the Spectrum Analyzer is off, and the Oscilloscope is on. The

AC/OFF/DC switch must be in either the AC or DC position. These two positions allow +12 V to the Oscilloscope Inverter Circuit Board (figure 6-28).

b. The Inverter Circuit Board is the power supply for the crt. It uses the +12 V allowed by the AC/OFF/DC switch as a source for the switching regulator: --2000 V dc is developed for the crt cathode, and +200 V dc is developed for the horizontal and vertical deflection plates of the crt. The crt heater voltage is also developed. The Inverter Board sends signals to the CRT for blanking of the retrace, and it also controls the intensity and focus of the crt trace.

c. Vertical inputs to the crt are derived by the oscilloscope Main Circuit Board (figure 6-30) from either the input to the SCOPE IN connector, or from the 15/6/1.5 KHz positions of the EXT V/DIV control. For internal modulation, AM modulation is applied to the Main Circuit Board from the 250-kHz Intermediate Frequency on the 250-kHz I.F. Monitor Audio Circuit Board (figure 6-21), and frequency deviation is applied to the Main Circuit Board from the FM audio output of the 250-kHz I.F. Monitor Audio Circuit Board. When using the oscilloscope as a general purpose test instrument to measure external inputs applied through the SCOPE IN connector, the EXT V/DIV Control must be in the .01 V/DIV, .1 V/DIV, 1 V/DIV, or 10 V/DIV position. The EXT V/DIV vernier control reduces the signal amplitude when it is not in the CAL position. The Main Circuit Board applies the signals derived from either the SCOPE IN connector or the 15/6/1.5 KHz positions of the EXT V/DIV control to the crt to control the vertical position of the trace. These inputs to the crt are either ac or dc coupled. The VERT control adjusts the vertical position of the crt trace.

d. Horizontal inputs to the crt derived from the internal sweep, according to the position of the SWEEP control. The internal sweep comes from the internal sweep generator on the Main Circuit Board. When the SWEEP control is fully ccw, the sweep frequency equals the tone generator output frequency, and the length of the sweep is controlled by the amplitude of the tone generator output. The SWEEP vernier control increases the number of pulses displayed when it is not in the CAL position. The HORIZ control adjusts the horizontal position of the crt trace.

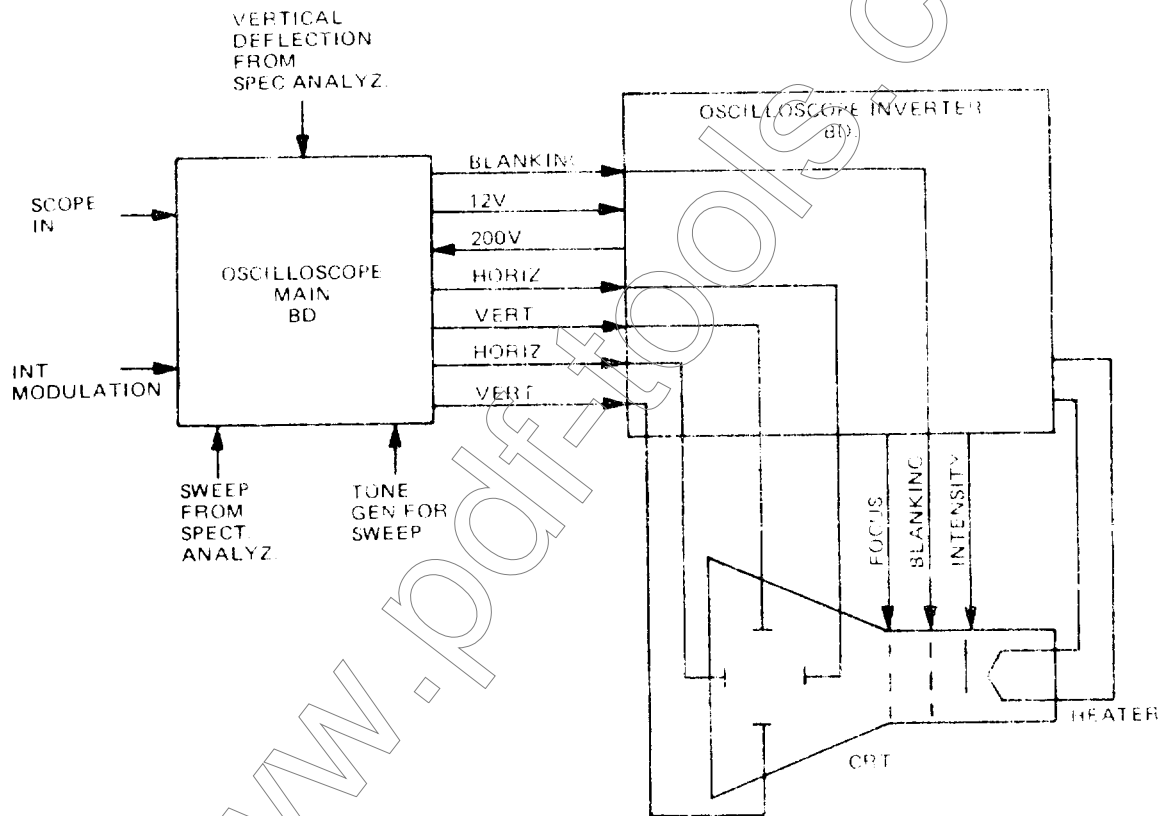


Figure 3-8. Oscilloscope block diagram

3-9. Spectrum Analyzer Theory. (Refer to figure 3-9 for a block diagram of Spectrum Analyzer Circuit Board 1, and to Figure 3-10 for a block diagram of Spectrum Analyzer Circuit Board 2.)

a. TO turn the Spectrum Analyzer on, the AC/OFF/DC switch must be in either the AC or DC position. This applies power (+12 V ) to the oscilloscope Inverter Circuit Board (figure 6-28). The ANALY DISPR control must be out of the fully ccw, or detent position. When it is out of detent, the Oscilloscope inputs to the horizontal and vertical deflective plates of the crt are disabled, the Spectrum Analyzer inputs to the horizontal and vertical deflection plates are enabled, and the HORIZ and VERT controls are disabled.

b. Amplitude is displayed by the Spectrum Analyzer in the following manner. Spectrum Analyzer Module No. 1 (figure 6-27) receives a 1.20-MHz input from the 2nd Mixer (figure 6-33). The signal is amplified and filtered, then mixed with the swept frequency of a Voltage Controlled oscillator (V.C.O.) which has a center frequency of 145-MHz. The resulting 25-MHz signal is filtered by a 25-MHz crystal filter, which has a bandpass of 30 kHz. The 25-MHz signal then mixes with a signal from a 26-MHz crystal oscillator. This produces a 1-MHz signal which is applied to the logarithmic (log) amplifier on Spectrum Analyzer Module No. 2 (figure 6-29) Output of the log amplifier is applied to a detector, and output of the detector is applied to the Spectrum Analyzer input of the vertical deflection amplifier on the oscilloscope Main Circuit Board (figure 6-30). A signal is then applied from the Main Circuit Board to the Inverter Circuit Board, then to the vertical deflection plates of the crt to display the amplitude.

c. Frequency is displayed on the Spectrum Analyzer in the following manner. An 18-Hz sawtooth, signal produced on Spectrum Analyzer Module No. 1 is the crt sweep signal. It is applied to the varactor tune circuit on Spectrum Analyzer Module No. 1. The varactor tune voltage is controlled by the ANALY DISPR control. When the ANALY DISPR control is turned ccw, but short of detent, dispersion is minimum, and the varactor causes the V.C.O. to sweep from 145.5-MHz to 144.5-MHz at an 18-Hz rate. When the ANALY DISPR control is fully cw, dispersion is maximum and the varactor causes the V.C.O. to sweep from 150-MHz to 140-MHz at an 18-Hz rate. The sweep-

ing V.C.O. allows signals to be viewed during minimum dispersion which are  $\pm 500$ -kHz from the frequency of the FREQUENCY MHz thumbwheels. During maximum dispersion, signals may be viewed which are + 5 MHz from the frequency of the FREQUENCY MHz thumbwheels. The V.C.O. is phase locked to the 5.12 MHz crystal oscillator on Module No. 2 to keep the center frequency at 145-MHz.

3-10. MM-100 (Multimeter) Theory. (Refer to figure 3-11 for a block diagram.)

a. The MM-100 is powered by +12 V dc through its accessory cable at the EXT ACC connector.

b. Measurements of AM% of modulation use a modulation frequency of 1-kHz. AM% of modulation information is derived from demodulated output from the AN/GRM-114. Demodulated input to the MM-100 is transformer coupled for isolation. Then it is applied to a peak detector, and a corresponding dc voltage is applied to the meter driver. The AM% of modulation is read on the top scale ( 0-1-100% ) of the meter.

c. When measuring ohms, the x1 position of the probe is recommended, because there is less than 1 W from the tip of the probe to the probe output connector. The FUNCTION control must be in the OHMS (only) position. The RANGE control may be in any of the five OHMS positions (x1 through x 10k). The meter indication is read on the bottom scale (OHMS). The fuse protects the OHMS function only. 1 V dc is present at the INPUT connector. An operational amplifier feedback system provides accurate center scale reading.

d. The DC -- position of the FUNCTION control allows negative dc voltages to be measured. This position reverses the polarity of the INPUT connector by switching the center conductor to meter ground and switching the shield to an input amplifier. DC is applied to the meter driver through the loading resistors selected by the position of the RANGE switch (.1-300 V, full scale). Maximum input is --300 V dc either directly or with the probe in the x1 position. Maximum input is --800 V dc using the probe in the x10 position. DC --voltages are read on the top or second scale, depending on the value of full scale deflection, as determined by the position of the RANGE control.

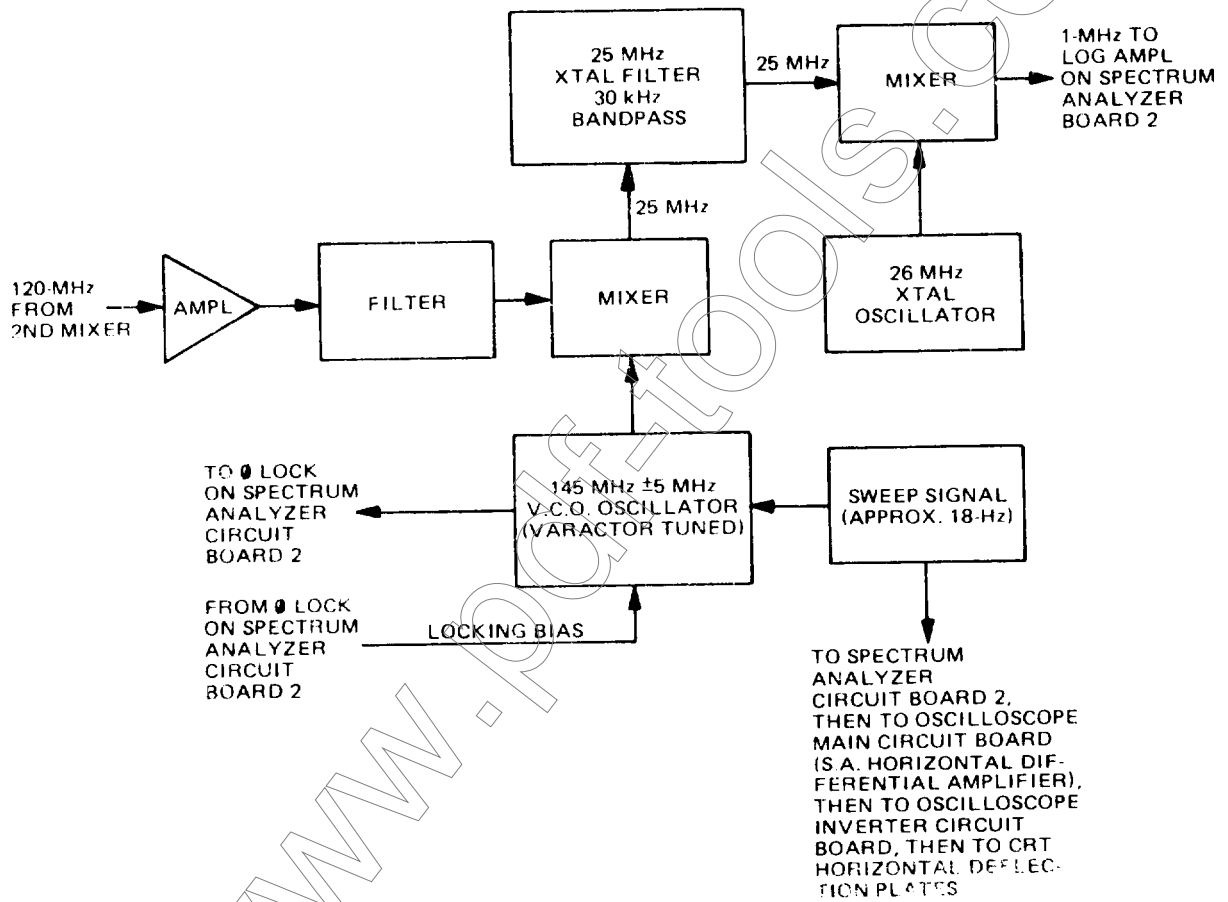


Figure 3-9. Spectrum analyzer circuit board 1 block diagram

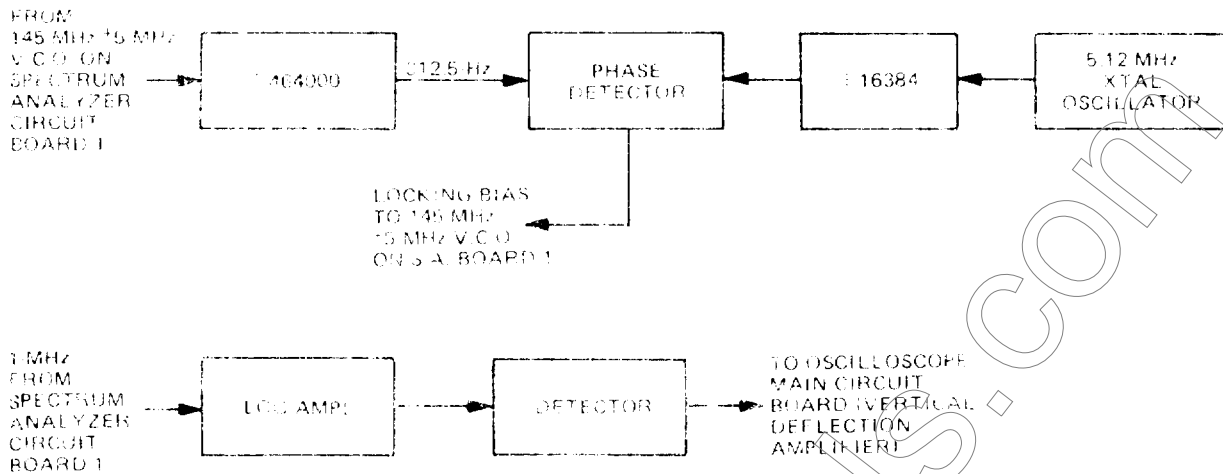


Figure 3-10. Spectrum analyzer circuit board 2 block diagram

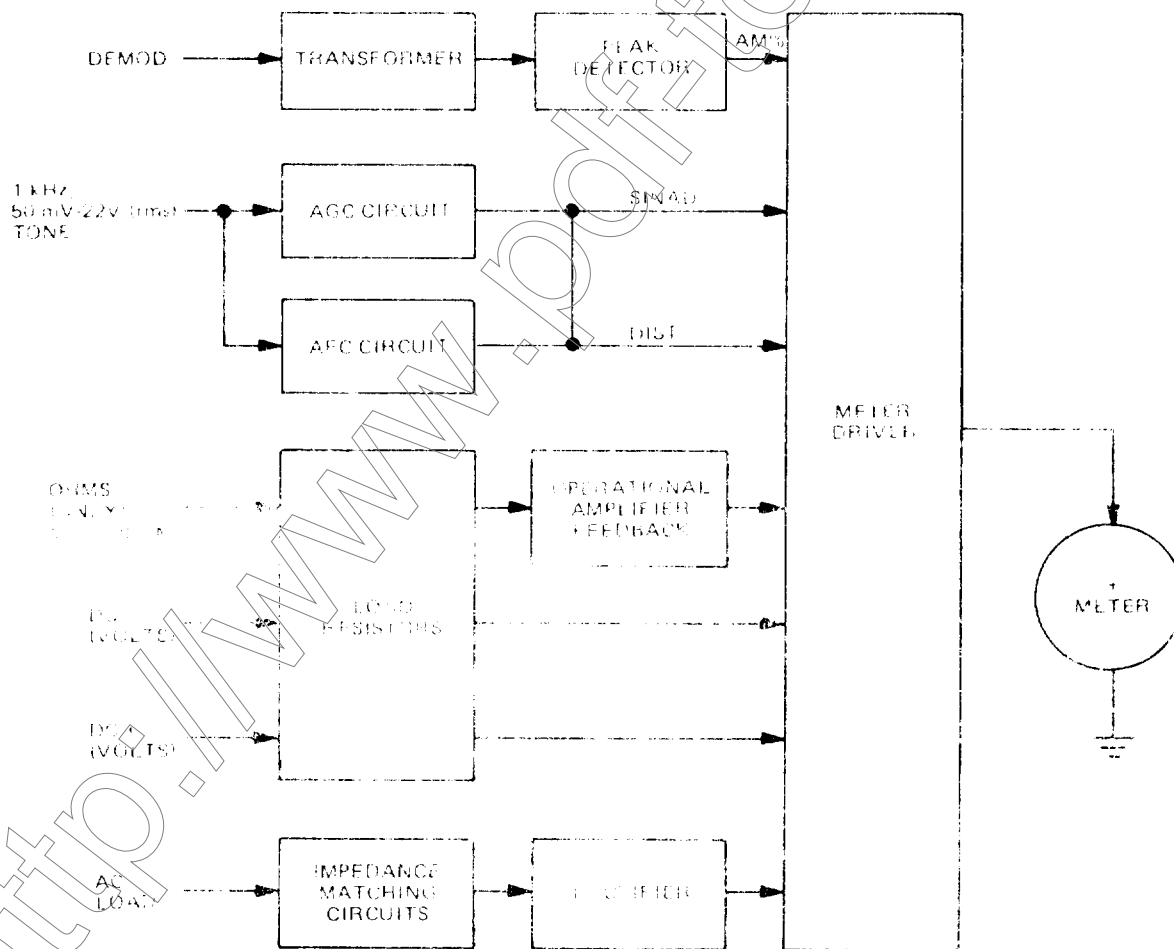


Figure 3-11. MM-100 (Multimeter) block diagram

e. When the FUNCTION control is in the DC+ position, positive dc voltage is measured. The polarity of the INPUT connector is normal, because the center conductor of the INPUT connector is switched to the input amplifier, and the shield is switched to meter ground. DC is applied to the meter driver through loading resistors selected by the position of the RANGE control (.1V-300V, full scale). Maximum input is 300 V dc, either directly, or with the probe in the x1 position. Maximum input is 800 V dc using the probe in the x10 position. DC+ voltages are read on the top or second scale depending on the value of full scale deflection, as determined by the setting of the RANGE control.

f. Input loading for ac voltages occurs through impedance matching circuits. There are five different AC LOAD positions for these circuits, HI-Z (1 M W) — 3.2 W. The position of the RANGE control selects the range of full scale deflection (.1V - 300 V). For direct input, 300 V ac is maximum input. 600 V ac is maximum input using the probe in the x10 position. The frequency range is 25-Hz to 25-kHz with the probe. Input ac voltages are rectified and passed to the meter driver. The dB scale (red scale) is provided for ac reference measurements.

g. When the RANGE control is in the SINAD position, the SINAD scale (blue scale), is calibrated in dB below 100% distortion. The FUNCTION control should be in the AC LOAD positions as required. SINAD measurements use a 1-kHz tone, 50 mV-22V (rms). Internal AGC and AFC circuits allow measurements to be made without level or frequency settings.

h. For the DIST (distortion) positions of the RANGE control, 0-10% is read on the top scale, and 0-30% is read on the 0 to 3 scale. Distortion measurements use a 1-kHz, 50-m V -22V (rms) tone only. Internal AGC and AFC circuits allow measurements to be made without level or frequency settings.

3-11. Power Supply Theory. (Refer to figure 3-12 for a block diagram. )

a. Power may be supplied to the AN/GRM-114 from the battery, from an external dc source, or from an external ac source. When operating on battery voltage, 12 V is applied from the battery to the Duty Cycle Regulator (figure 6-16) through

the battery fuse. For operation on an external dc voltage, +11 to +28 V dc is applied to the Duty Cycle Regulator through the external dc fuse. For operating on an ac voltage, the ac voltage is connected to the transformer through a fuse on the Rear Panel. The transformer steps down the ac input voltage to 9 V ac. This voltage is rectified by two bridge rectifiers. Unregulated dc voltage is fed to the Duty Cycle Regulator. When operating on an external ac or dc voltage, rectified ac or external dc is applied to the PWR/OFF/BATT switch. When the switch is in the PWR positions, voltage is applied through the normally closed contacts of the Duty Cycle Regulator relay to the Duty Cycle Regulator circuits. To operate on battery, the PWR/OFF/BATT Switch is depressed to the momentary BATT position. This sends a signal to the Regulator and Power Supply Circuit Board (figure 6-22) which energizes the Duty Cycle Regulator relay allowing battery voltage to be presented to the Duty Cycle Regulator circuits. To remove battery power, the PWR/OFF/BATT Switch is again depressed to the momentary battery position.

b. The Duty Cycle Regulator develops +5, +12 and -39 V dc regulated outputs from the source voltage. The +5 V dc output is used in logic circuits. The +12 V dc output is fed to the Oscilloscope Main Circuit Board (figure 6-30) and the Regulator and Power Supply Circuit Board. The -39 V dc output is fed to the Regulator and Power Supply Circuit Board. The Duty Cycle Regulator also provides a battery charging circuit. This circuit, which provides 15 V dc, operates only on an external voltage.

c. The Regulator and Power Supply Circuit Board receives inputs from the Duty Cycle Regulator. The Circuit Board develops +11, -12, and -35 V dc outputs for operation of circuit boards and mechanical assemblies. These voltages are current limited to prevent damage to the regulator circuits. The Circuit Board also contains a battery timer circuit, which turns the test set off after six to ten minutes of battery operation, and a low voltage cutoff circuit which prevents battery operation of the test set when the battery voltage is below 11 volts. The Circuit Board converts RF signals detected by the Power Monitor (figure 6-25) into dc voltages which are sent to the DEVIATION (KHz)/WATTS meter for power measurements. It also switches the AN/GRM-114 between the generate and receive modes.



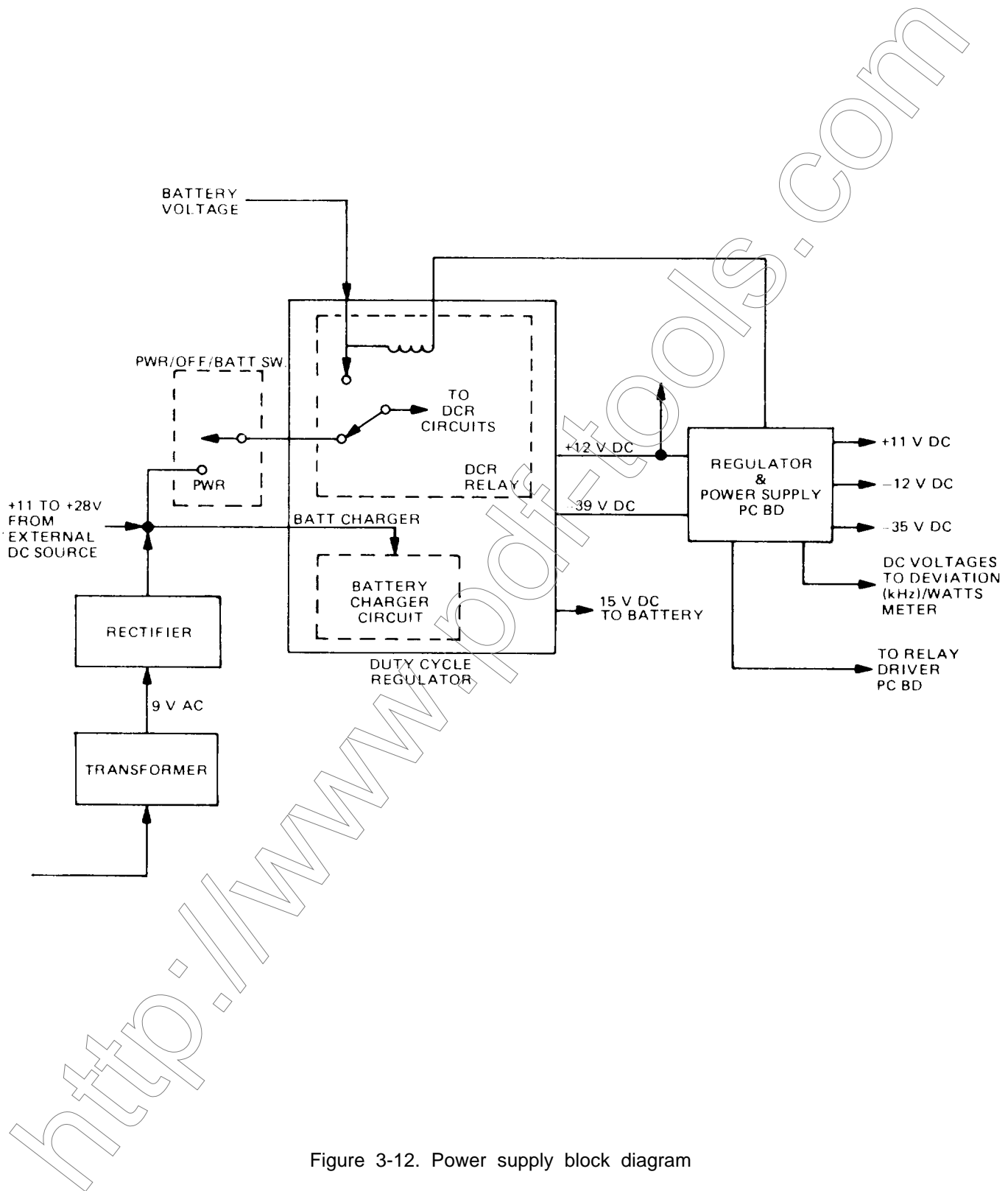


Figure 3-12. Power supply block diagram

CHAPTER 4

OPERATING INSTRUCTIONS

**CAUTION**

A transmitter must only be connected to the TRANS/RCVR connector on the front panel of the AN/GRM-114. Connecting a transmitter to any other connector will severely damage the AN/GRM-114.

**4-1. Operating Procedures** Observe the following precautions when operating the AN/GRM-114:

- a. When working with "live" circuits of high potential, keep one hand in pocket or behind back to avoid serious shock hazard.
- b. Remove all jewelry or other cosmetic apparel before performing any test procedures involving "live" circuits.
- c. Use only insulated troubleshooting tools when working with "live" circuits.
- d. For added insulation, place rubber bench mat underneath all powered bench equipment, as well as a rubber floor mat underneath operator chair.
- e. Heed all WARNINGS and CAUTIONS concerning maximum voltage and power inputs.

f. When operating AN/GRM-114 in conjunction with a unit under test (UUT), apply power in following sequence:

- (1) The device receiving an input is energized first.
- (2) The device generating an output is energized second.

g. Avoid using oscilloscope/spectrum analyzer in direct sunlight as scope trace is difficult to see under these conditions.

h. Do not allow scope trace to become concentrated on CRT as a stationary spot, as CRT screen may be burned permanently. Reduce trace intensity if trace must remain stationary.

i. Protect AN/GRM-114 from vibration or mechanical shock. The CRT is highly evacuated and if broken, will implode, causing possible serious injury from fragmented glass.

**4-2. AN/GRM-114 Controls, indicators, and Connectors.** Table 4-1 lists the controls, indicators, anti connectors (figure 4-1) of the AN/GRM-114.

Table 4-1. AN/GRM-114 Controls, Indicators, and Connectors

Control, indicator, or connector	Function
DEVIATION (KHz) /WATTS meter	Provides visual display of peak FM deviation, transmitter output power, received signal strength, and internal battery charge condition.
0 dBm lamp	Lights when rf signal output is at 0 dBm or above.
HI LVL/ $\mu$ V x 100/NORM switch	3-position switch which selects power range for RF LEVEL/BFO INJECTION dial as follows: NORM position - RF/BFO output level is equal to setting of RF LEVEL/ BFO INJECTION dial on $\mu$ V (microvolts) or dBm (decibels referenced to 1 milliwatt) scale.

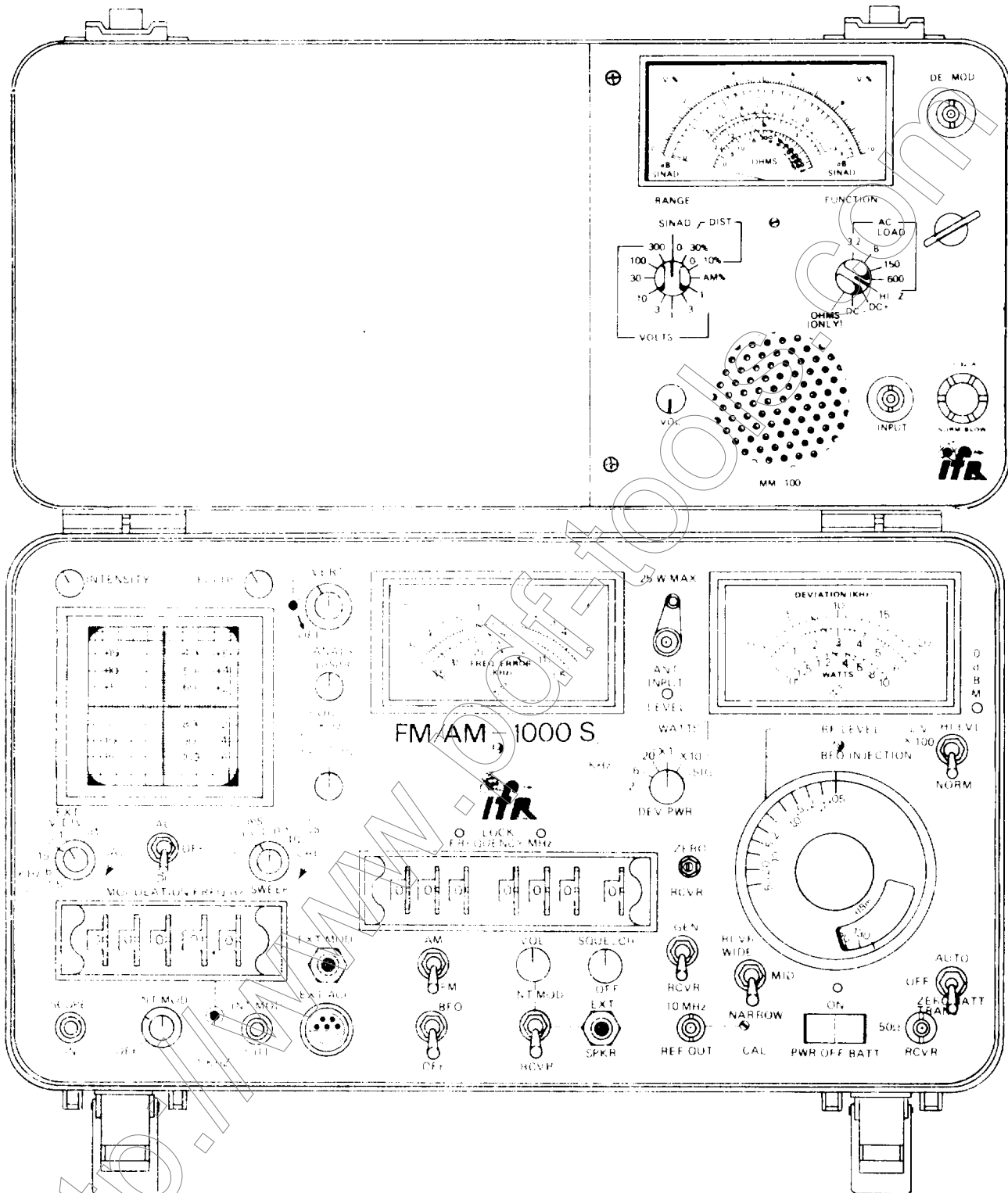


Figure 4-1. AN/GRM-114 controls, indicators, and connectors

Table -4-1. AN/GRM-114 Controls, Indicators, and Connectors – Continued

Control, indicator, or connector	Function
HI LVL/ $\mu$ V x 100/NORM switch - Continued	<p><math>\mu</math>V x 100 position - RF/BFO output level is 100 times the RF LEVEL/BFO INJECTION dial setting on the <math>\mu</math>V scale. (Equivalent level in dBm is equal to reading of dBm scale, plus 40 db.)</p>
ZERO RCVR adjustment	<p>HI LVL position - Enables RF output levels above -35 dBm to be achieved.</p> <p>Adjustment screw for zeroing FREQ. ERROR meter when power is ON.</p>
RF LEVEL/BFO INJECTION dial	<p>Controls RF output level when set is operating in signal GEN mode and beat frequency oscillator (bfo) injection level when operating in RCVR mode. Control knob contains scales for levels in both <math>\mu</math>V and dBm (decibels referenced to 1 milliwatt).</p>
AUTO/OFF/ZERO, BATT switch	<p>3-position switch which activates/deactivates auto-zeroing circuit and provides a visual indication of internal battery voltage condition as follows:</p> <p>AUTO position - Auto-zeroing circuit is activated, automatically zeroing receiver and FREQ. ERROR meter through an internal self-check.</p> <p>OFF position - Auto-zeroing circuit is deactivated.</p> <p>ZERO, BATT position - When switch is held in this springloaded position, a visual indication of internal battery voltage is displayed on DEVIATION (KHz)/WATTS meter BATT (green) scale.</p>

<http://www.pdf-tutorials.com>

Table 4-1. AN/GRM-114 Controls, Indicators, and Connectors – Continued

Control, indicator, or connector	Function
<p>AUTO/OFF/ZERO, BATT switch – Continued</p>	<p style="text-align: center;">NOTE</p> <p>AN/GRM-114 should not be used as test set when switch is in this position. When activated, auto-zeroing reference pulse will cause minor cathode ray tube (crt) trace and meter needle deflections to occur; this is a normal operating condition and should be disregarded.</p> <p>With auto-zeroing circuit activated, a 3-ms void will be produced by reference pulse every 1.5 seconds in generate or receive modes. If this conditions hinders testing of unit under test (UUT), place switch to OFF position. In OFF position, FREQ. ERROR meter is not calibrated and should not be used for frequency error measurements.</p>
<p>TRANS/RCVR connector</p>	<p>50 W rf input/output connector for UUT.</p>
<p>ON lamp</p>	<p>Lights when power is applied.</p>
<p>PWR/OFF/BATT switch</p>	<p>3-position switch which supplies/interrupts power as follows:</p> <ul style="list-style-type: none"> <li> <p>PWR (leftmost position)</p> <ul style="list-style-type: none"> <li>- Allows application of external ac or dc power.</li> </ul> </li> <li> <p>Off-center position)</p> <ul style="list-style-type: none"> <li>- Shuts off power to all circuits, except battery charger circuit.</li> </ul> </li> <li> <p>BATT (rightmost position)</p> <ul style="list-style-type: none"> <li>- Powers AN/GRM-114 by its internal battery; set will turn off automatically after approximately eight minutes of operation, to prevent battery rundown.</li> </ul> </li> </ul>

Table 4-1. AN/GRM-114 Controls, Indicators, and Connectors --- Continued

Control, indicator, or connector	Function
PWR/OFF/BATT switch – Continued	<p style="text-align: center;">NOTE</p> <p>AN/GRM-114 internal battery is charging whenever test set is connected to an ac power source, including times when power switch is OFF.</p>
RCVR WIDE/MID/NARROW switch	Selects WIDE, MID or NARROW bandwidth of AN/GRM-114 receiver.
GEN/RCVR switch	<p>Controls operating mode of AN/GRM-114 as a signal generator or receiver as follows:</p> <p>GEN position - AN/GRM-114 functions as a signal generator, producing rf output at TRANS/RCVR connector. If rf energy is applied to this connector while set, is in generator mode, set will automatically switch to receiver mode.</p> <p>RCVR position - AN/GRM-114 functions as a receiver. Signal input (0.1 watt minimum required) may be applied through the TRANS/RCVR connector or “off-the-air” from an external antenna attached to ANT INPUT connector.</p>
10 MHz CAL adjustment	Fine tuning adjustment for 10-MHz master oscillator frequency.
10 MHz REF OUT connector	10-MHz master oscillator output connector.
EXT SPKR connector	Audio output connector for remote speaker or headphones.
SQUELCH/OFF control	Squelch threshold adjustment; squelch disables audio output when rf input at ANT INPUT connector falls below squelch threshold.

Table 4-1. AN/GRM-114 Controls, Indicators, and Connectors – Continued

Control, indicator, or connector	Function
SQUELCH/OFF control – Continued,	NOTE  SQUELCH control is OFF when fully ccw in detent position. When out of detent position, rotate control cw to increase squelch threshold or ccw to decrease threshold. (The greater the squelch threshold, the greater the signal input required to break the threshold).
INT MOD/RCVR switch	Couples receiver or dual tone generator audio output to internal speaker through VOL control.
VOL control	Controls audio output level of internal speaker (or external accessory speaker when connected to EXT SPKR connector).
BFO/OFF switch	Activates or deactivates internal beat frequency oscillator (bfo).
AM/FM switch	Selects signal mode to be generated or received as follows:  AM position - Generates or receives amplitude modulated (AM) signals.  FM position - Generates or receives frequency modulated (FM) signals.
EXT ACC connector	Output connector providing power or signal sources for external accessory equipment. (See Appendix D for connector pin assignments).
EXT MOD connector	Input connector for external modulation sources.
INT MOD OUT connector	Output connector which couples dual tone generator audio output to external devices. Output level is controlled by INT MOD/OFF (outer control) and 1 kHz INT MOD/OFF (inner control).

Table 4-1. AN/GRM-114 Controls, Indicators, and Connectors – Continued

Control, indicator, or connector	Function
INT MOD OUT connector – Continued	<p><b>NOTE</b></p> <p>Output can consist of one or any combination of following modulated signals mixed together:</p> <p>1 kHz internal modulation, variable internal modulation, and external modulation.</p>
INT MOD/OFF	<p>Controls % of AM modulation or FM peak deviation of frequency selected on MODULATION FREQ. Hz thumbwheels. Modulation control is OFF in full ccw (detent position); when out of detent, rotate control cw to increase modulation level.</p>
1 KHz INT MOD/OFF control	<p><b>NOTE</b></p> <p>Modulation frequency can be externally keyed through the EXT MOD connector.</p>
MODULATION FREQ. Hz thumbwheels	<p>Controls % of AM modulation or FM peak deviation for an approximate 1-kHz tone. Modulation control is OFF in full ccw (detent position); when out of detent, rotate control cw to increase modulation level.</p>
SCOPE IN connector	<p>Select internal modulation frequency produced by dual tone generator (10.0 Hz through 9999.9 HZ).</p>
SWEEP control	<p>Vertical deflection input for oscilloscope.</p>
SWEEP vernier control	<p>Controls horizontal sweep speed of oscilloscope in indicated increments per graticule division.</p>
	<p>Permits continuous variation of sweep speed within any of the ranges provided by SWEEP control. In CAL position (fullyw, detent), oscilloscope horizontal graticule divisions are equal to setting of SWEEP control.</p> <p><b>NOTE</b></p> <p>Do not make time measurements with SWEEP vernier control out of CAL position.</p>



Table 4-1. AN/GRM-114 Controls, Indicators, and Connector--Continued

Control, indicator, or connector	Function
AC/DC/OFF switch	<p>3 -position switch which ac couples scope inputs when in AC position; dc couples scope inputs when in DC position; and disconnects power from oscilloscope/spectrum analyzer in OFF position.</p> <p style="text-align: center;">NOTE</p> <p>When switching from one coupling mode to another, pause briefly in OFF position; this ensures that scope power supply inverter will start.</p> <p>To conserve power during battery operation, place coupling switch to OFF when oscilloscope or spectrum analyzer is not in use.</p>
EXT V/DIV control	<p>Controls oscilloscope vertical sensitivity and input source applied to oscilloscope as follows:</p> <p>EXT V/DIV positions</p> <ul style="list-style-type: none"> <li>- Selects oscilloscope vertical sensitivity (in indicated voltage increments per graticule division) for signals applied to SCOPE IN connector.</li> </ul> <p>KHz positions</p> <ul style="list-style-type: none"> <li>- Oscilloscope displays frequency deviation (in FM mode) or modulation envelope (in AM mode).</li> </ul> <p style="text-align: center;">NOTE</p> <p>If EXT V/DIV control is in 15 or 1.5 KHz position, frequency deviation is read on left-hand vertical scale. If control is in 6 KHz position, frequency deviation is read on right-hand vertical scale. If viewing modulation in AM mode, the position of EXT V/DIV in the KHz range is irrelevant.</p>

Table 4-1. AN/GRM-114 Controls, Indicators, and Connectors – Continued

Control, indicator, or connector	Function
EXT V/DIV vernier control	Permits variation of oscilloscope vertical sensitivity within any of the ranges provided by EXT V/DIV control. in CAL position (fully cw, detent), oscilloscope vertical graticule divisions are equal to setting of EXT V/DIV control.  NOTE  Do not make voltage measurements with EXT V/DIV vernier control out of CAL position.
FREQUENCY MHz thumbwheels	Selects frequency of signal generator or receiver.  NOTE  Left hand thumb wheel selects frequency in 100-MHz steps. Right-hand thumbwheel selects frequency in 100-Hz steps.
1.5/5/15 KHz control	Selects full-scale sensitivity of FREQ. ERROR (KHz) meter.
Cathode ray tube (crt) display	Display screen for AN/GRM-114 oscilloscope or spectrum analyzer.
INTENSITY control	Controls brightness of crt trace. Rotate control ccw to decrease brightness, cw to increase brightness.  NOTE  Warmup time of crt is approximately 30 seconds from a cold start-up; trace display will not become visible until crt achieves warmup.
HORIZ control	Controls horizontal position of oscilloscope trace. Rotate control cw to move trace to right, ccw to move trace to left.
FOCUS control	Controls sharpness of oscilloscope trace.
VERT control	Controls vertical position of oscilloscope trace. Rotate control cw to move trace up, ccw to move trace down.

Table 4-1. AN/GRM-114 Controls, Indicators, and Connectors – Continued

Control, indicator, or connector	Function
ANALY DISP/OFF control	Continuously varies spectrum analyzer dispersion within a span of 1 to 10 MHz. Full cw rotation of control provides a dispersion of 1 MHz per major graticule division; full ccw rotation (short of detent position) provides a dispersion of 500 kHz per major graticule division. In full ccw detent position, spectrum analyzer is off and oscilloscope is on.
LOCK (left lamp)	When lit, indicates proper operation of high frequency phase lock loop. Lamp will blink momentarily when MHz segments of FREQUENCY MHz thumbwheels are increased in value or decreased in value, however lamp should remain lit at all other times when power is applied.
LOCK (right lamp)	When lit, indicates proper operation of 79-80 MHz low frequency phase lock board in AN/GRM-114. Lamp will blink momentarily when kHz and Hz segments of FREQUENCY MHz thumbwheels are increased or decreased in value; however, lamp should remain lit at all other times when power is applied.
FREQ. ERROR (KHz) meter	Provides visual display of difference between received signal frequency and AN/GRM-114 receiver frequency (as represented by FREQUENCY MHz thumbwheel setting).
FREQ. ERROR (KHz) zero adjustment (located below meter)	Mechanical zero adjustment of FREQ. ERROR (KHz) meter intended for use when power is off.
ANT INPUT LEVEL lamp	External antenna input to AN/GRM-114, used primarily for off-the-air testing.
LEVEL lamp	When lit, indicates that input level at ANT INPUT connector is above the squelch threshold of AN/GRM-114 receiver.

NOTE

During spectrum analyzer operation, all oscilloscope controls except INTENSITY control, FOCUS control and AC/OFF/DC switch are disabled. Spectrum analyzer can be turned off using AC/OFF/DC switch.

Table 4-1. AN/GRM-114 Controls, Indicators, and Connectors — Continued

Control, indicator, or connector	Function
<p>DEV/PWR control</p>	<p>Provides visual display of peak FM frequency deviation, input power at TRANS/RCVR and received signal strength as follows:</p> <p>KHz positions - Selects full scale range for peak FM deviation as displayed by DEVIATION (KHz)/WATTS meter.</p> <p>WATTS positions - Selects multiplier for output power measurements on WATTS scale of DEVIATION (KHz)/WATTS meter.</p> <p>SIG position - For signals received off the air, representation of relative signal strength can be determined by observing DEVIATION (KHz)/WATTS meter needle deflection. As signal strength increases, the meter needle deflection will increase towards right of meter scale.</p>
<p>DEVIATION (KHz) /WATTS meter, zero adjustment (located below meter)</p>	<p>Mechanical zero adjustment of DEVIATION (KHz)/WATTS meter intended for use when power is off.</p>
<p>NOTE</p> <p>The following controls and indicators are located on the MM-100.</p>	
<p>Meter indicator</p> <p>NOTE</p> <p>All signals indicated on the Meter require connection to the INPUT jack except AM% modulation, which is an internal connection.</p>	<p>Provides visual display of external ac voltage, external dc voltage, peak AM% modulation % distortion of received, generated signal, and external resistance.</p>
<p>DE-MOD connector</p>	<p>Provides a demodulated signal from an rf input signal, that is read on meter when DE-MOD jack is connected to INPUT jack.</p>

Table 4-1. AN/GRM-114 Controls, Indicators, and Connectors – Continued

Control, indicator, or connector	Function
FUNCTION control	<p>AC LOAD positions - Provides ac resistance in amounts listed.</p> <p>DC positions - Provides high impedance dc input.</p> <p>OHMS (only position) - For use when measuring resistance.</p>
INPUT connector	Input connector for MM-100 probe or test cable.
VOL control	Controls audio output of MM-100 internal speaker.
RANGE control	<p>Controls meter display as follows:</p> <p>VOLTS positions - When FUNCTION control is in DC positions, value of VOLTS position represents full scale meter deflection for dc voltage. When FUNCTION control is in AC positions, value of VOLTS position represents full scale meter deflection for ac voltage.</p> <p>OHMS position - When FUNCTION control is in OHMS (only) position, measured resistance equals value of OHMS scale (on meter) times value of OHMS position (on RANGE control).</p> <p>AM% position - Peak AM% modulation is displayed on top scale of meter.</p>

Table 4-1. AN/GRM-114 Controls, Indicators, and Connectors – Continued

Control, indicator, or connector	Function
RANGE control — Continued	<p>DIST positions - Top or second scale of meter (depending on value of position) displays % distortion.</p> <p>SINAD position - Meter indicates value of signal, noise, and distortion on SINAD scale.</p> <p><b>NOTE</b></p> <p>DIST and SINAD positions are intended for use at 1 kHz only.</p>

4-3. Operating Procedures. Table 4-2 lists start-up procedures, emergency operating procedures, and stopping procedures for the AN/GRM-114.

4-4. RF Signal Generator Operating Instructions. Table 4-3 lists the initial adjustments

and control settings (figure 4-2) necessary to generate rf signals. Table 4-4 lists the operating instructions. Refer to table 4-5 for operating instructions for AM signals and refer to table 4-6 for operating instructions for FM signals.

Table 4-2. AN/GRM-114 Operating Procedures

Condition	Procedure
startup	<p>a. For battery operation, set PWR/OFF/BATT switch on front panel to BATT.</p> <p><b>NOTE</b></p> <p>Battery will operate for 40 minutes before requiring recharging if oscilloscope is being used, and for 1 hour if it is not. Battery may be recharged from external ac power source while source powers AN/GRM-114. Whether oscilloscope is being used or not, AN/GRM-114 will shut off every 6-10 minutes. When it does, immediately set PWR/OFF/BATT switch to BATT position. Power will return to unit.</p> <p>For operating from external ac or dc power source, connect 6-pin socket on end of furnished ac or dc power cable to 6-pin plug on rear panel.</p>

Table 4-2. AN/GRM-114 Operating Procedures – Continued

Condition	Procedure
Startup (Continued)	<p>b. For ac operation, connect 3-pin grounded plug of ac power cable to standard 3-pin grounded outlet.</p> <div data-bbox="1027 417 1219 485" style="border: 1px solid black; padding: 5px; text-align: center; margin: 10px 0;"> <p><b>WARNING</b></p> </div> <p style="margin-left: 40px;">Do not connect 3-pin grounded plug to 2-pin outlet through an adapter. Electrical shock may result.</p> <p>c. For dc operation, connect cigarette lighter adapter of dc power cable to cigarette lighter socket.</p> <p>d. Set the PWR/OFF/BATT switch on front panel to PWR.</p>
Emergency	<p>If battery weakens and recharging is not practical, first disconnect power from UUT (if UUT is connected), then set PWR/OFF/BATT switch on front panel to OFF position, connect external ac or dc power supply as specified in paragraphs a, b, or c above, then set PWR/OFF/BATT switch to PWR position. Finally, connect power to UUT (if UUT is connected).</p>
Stopping	<p>Disconnect power from UUT (if UUT is connected). Set PWR/OFF/BATT switch on front panel to OFF position. Disconnect UUT from AN/GRM-114. Remove power cable socket from plug on rear panel then remove either 3-pin grounded plug (ac power cable) from 3-pin grounded outlet, or cigarette lighter adapter from cigarette lighter socket.</p>

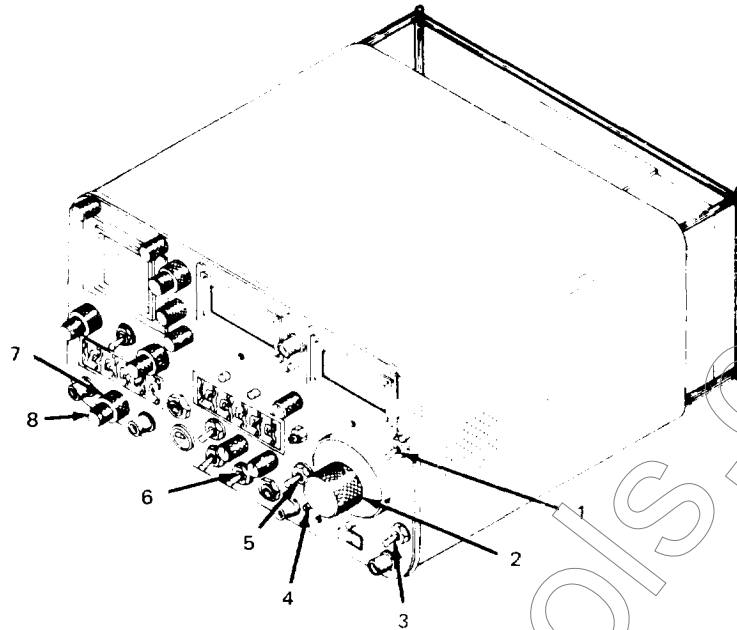


Figure 4-2. RF signal generator controls, indicators, and connectors

Table 4-3. RF Signal Generator Initial Adjustments anti Control Settings

Figure 4-2 Reference No.	Control, indicator, or connector	Initial adjustment or setting
1	HI LVL/μV x 100/NORM switch	NORM
2	RF LEVEL/BFO INJECTION dial	Fully ccw
3	AUTO/OFF/ZERO, BATT switch	AUTO
4	RCVR WIDE/MID/NARROW switch	NARROW
5	GEN/RCVR switch	GEN
6	INT MOD/RCVR switch	RCVR
7	INT MOD/OFF switch	Fully ccw, detent (OFF)
8	1 kHz INT MOD control	Fully ccw, detent (OFF)
9	EXT V/DIV vernier	CAL
10	SWEEP vernier	Fully cw, detent CAL



Table 4-4. RF Signal Generator Operating Instructions

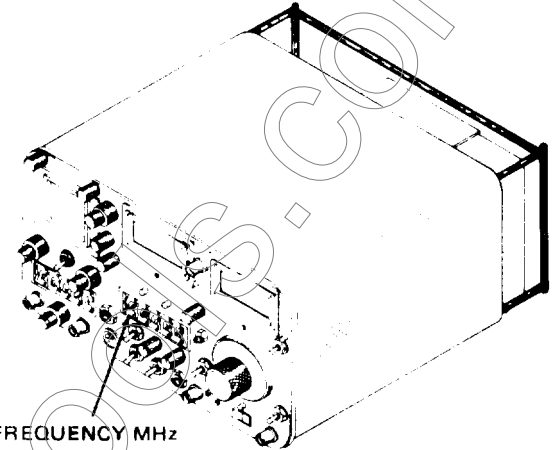
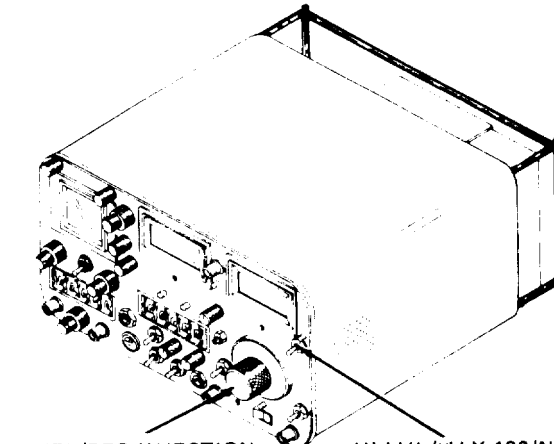
Step	Procedure	Illustration
1	<p>Set FREQUENCY MHz thumb wheels to desired rf frequency output.</p>	 <p>FREQUENCY MHz</p>
2	<p>For an rf output less than 50 <math>\mu</math>V, set HI LVL/<math>\mu</math>V x 100/NORM switch to NORM and rotate RF LEVEL/BFO INJECTION dial to desired <math>\mu</math>V setting.</p> <p style="text-align: center;"><b>NOTE</b></p> <p>RF output in dBm is indicated by the reading on dBm scale.</p> <p>The AN/GRM-114 is now generating rf signals at desired frequency and output level.</p>	 <p>RF LEVEL/BFO INJECTION</p> <p>HI LVL/<math>\mu</math>V X 100/NORM</p>

Table 4-4. RF Signal Generator Operating Instructions – Continued

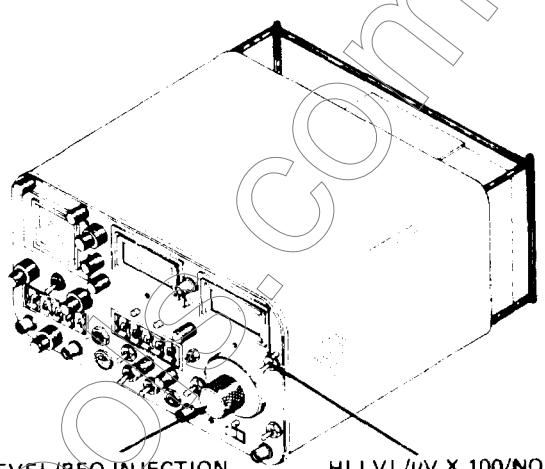
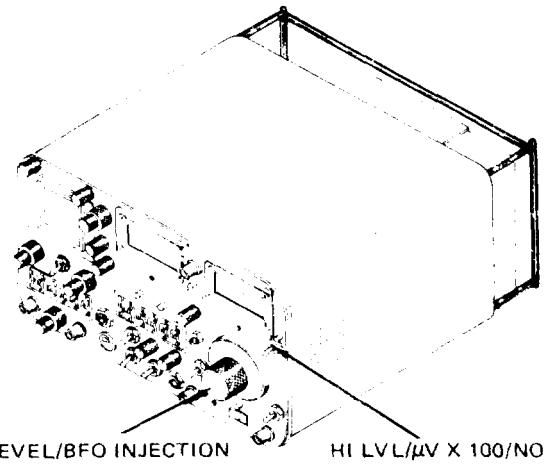
Step	Procedure	Illustration
<p>3</p>	<p>For an rf output level greater than 50<math>\mu</math>V (but less than 5000 <math>\mu</math>V):</p> <p>(a) Place HI LEVEL/<math>\mu</math>V X 100/NORM switch to <math>\mu</math>V X 100 position.</p> <p>(b) Rotate RF LEVEL/BFO INJECTION dial to desired <math>\mu</math>V setting. The AN/GRM-114 is now generating rf signals at desired frequency and output level.</p> <p style="text-align: center;">NOTE</p> <p>RF output level in <math>\mu</math>V is now 100 times the setting of RF LEVEL/BFO INJECTION dial on <math>\mu</math>V scale.</p> <p>Equivalent rf output level in dBm can be determined by mathematically adding +40 dBm to reading on dBm scale.</p>	
<p>4</p>	<p>For an rf output level greater than -35 dBm:</p> <p>(a) Place HI LVL/<math>\mu</math>V X 100/NORM switch to HI LVL position.</p> <p>(b) Slowly rotate RF LEVEL/BFO INJECTION dial cw until 0 dBm Lamp lights.</p> <p>(c) Record setting of RF LEVEL/BFO INJECTION dial on dBm scale.</p> <p>(d) Add result obtained in step 4. (c) to desired rf output level in dBm. Record result.</p> <p>(e) Rotate RF LEVEL/BFO INJECTION dial to setting obtained in step 4. (d).</p> <p>(f) The AN/GRM-114 is now generating rf signals at desired frequency and output level.</p>	

Table 4-5. RF Signal Generator Operating Instructions for AM RF Signals

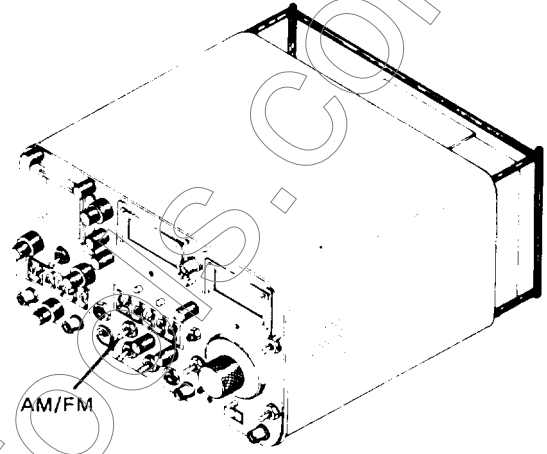
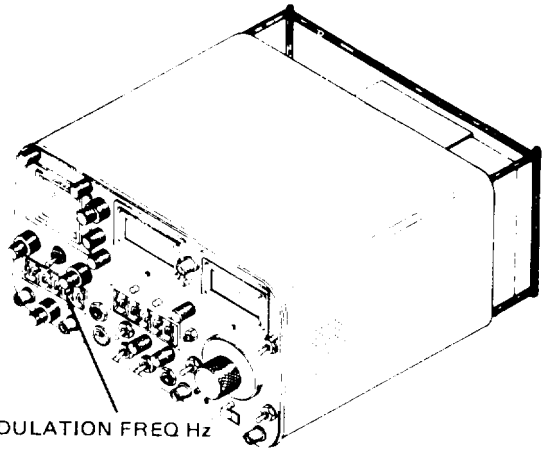
Step	Procedure	Illustration
1	Place AM/FM switch to AM.	 <p>The illustration shows a perspective view of the RF signal generator. A circular switch on the front panel is highlighted with a circle and labeled 'AM/FM'. The switch is currently in the 'FM' position.</p>
2	Set MODULATION FREQ Hz thumbwheels to desired tone modulation frequency.	 <p>The illustration shows a perspective view of the RF signal generator. Two thumbwheels on the front panel are highlighted with a circle and labeled 'MODULATION FREQ Hz'. The thumbwheels are currently set to '00'.</p>

Table 4-5. RF Signal Generator Operating Instructions for AM RF Signals -- Continued

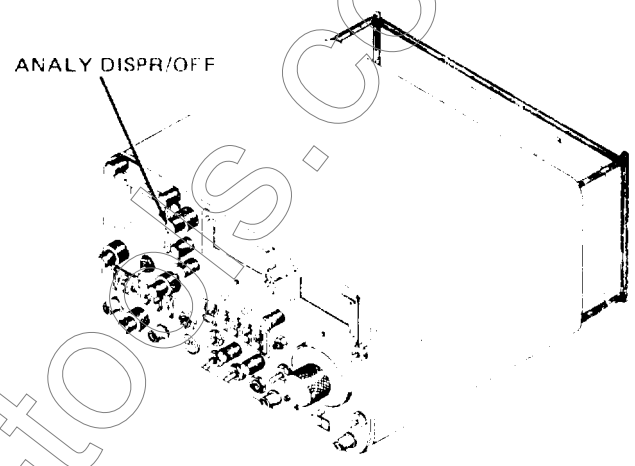
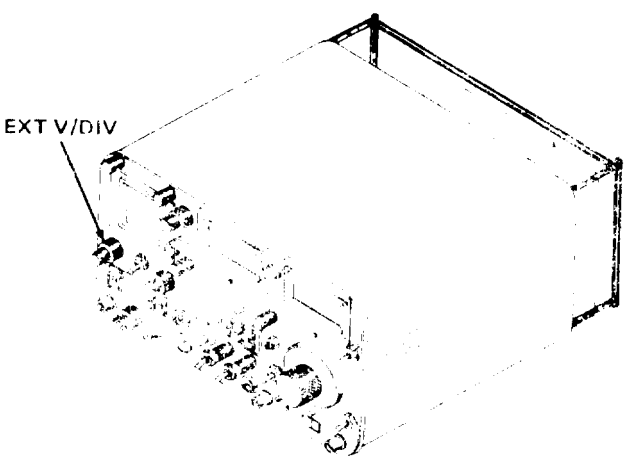
Step	Procedure	Illustration
3	Rotate ANALY DISPR/OFF control fully ccw to detent position.	 <p>ANALY DISPR/OFF</p>
1	Place EXT V/DIV, control to 1.5 KHz, 6KHz or 15 KHz.	 <p>EXT V/DIV</p>

Table 4-5. RF Signal Generator Operating Instructions for AM RF Signals - Continued

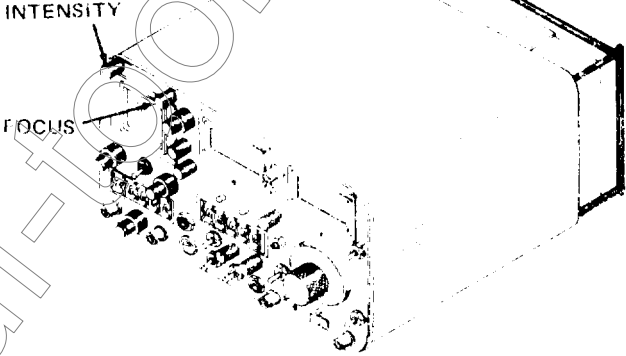
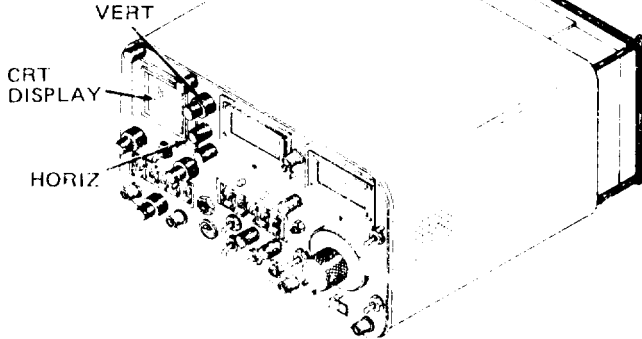
Step	Procedure	Illustration
5	<p>When applying power to oscilloscope or Spectrum analyzer through PWR/OFF/BATT switch or AC/DC/OFF switch, make sure INTENSITY control is as moderate (left) position.</p> <p>Adjust INTENSITY control cw and FOCUS control appropriately for a sharp visible trace display.</p>	 <p>This illustration shows a close-up of the control panel on the left side of the device. Two knobs are highlighted with arrows and labels: 'INTENSITY' and 'FOCUS'. The INTENSITY knob is positioned towards the left side of its range, and the FOCUS knob is also positioned towards the left side of its range.</p>
6	<p>Adjust VERT control and HORIZ control to obtain a centered trace, with lower edge of displayed carrier aligned with major horizontal axis.</p>	 <p>This illustration shows a close-up of the control panel on the left side of the device. Three knobs are highlighted with arrows and labels: 'VERT', 'CRT DISPLAY', and 'HORIZ'. The VERT knob is positioned towards the top of its range, and the HORIZ knob is positioned towards the left side of its range.</p>

Table 4-5. RF Signal Generator Operating Instructions for AM RF Signals – Continued

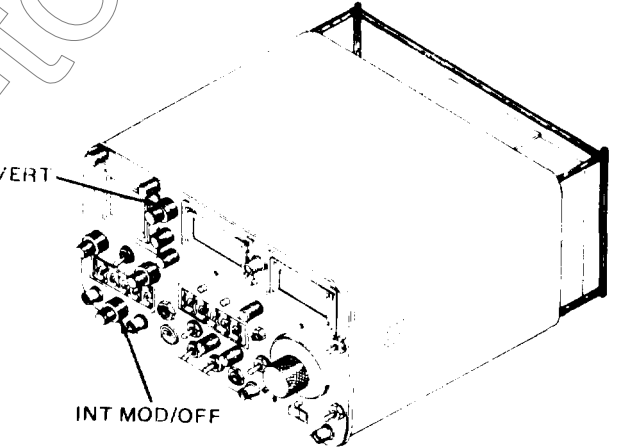
Step	Procedure	Illustration
7	Measure peak-to-peak amplitude (in graticule divisions) of displayed carrier. Record result.	
8	Apply result obtained in step 7 to the following equation:  $x = \frac{(\text{desired \% modulation}) \times (\text{result of step 7})}{100}$	
9	where: x = number of graticule divisions (peak-to-peak) of modulated signal.  NOTE  Steps 9. (a) and (b) must be performed simultaneously, as one will affect the other.  (a) Adjust VERT control to align negative peak of the modulated signal with the major horizontal axis.  (b) Rotate INT MOD/OFF control to adjust peak-to-peak amplitude of the same modulated signal (in graticule divisions) to the value of x obtained in step 8.  (c) The signal generator is now calibrated to the desired percent modulation and is generating at the selected frequency and output level.	

Table 4-6. RF Signal Generator Operating Instructions for FM RF Signals

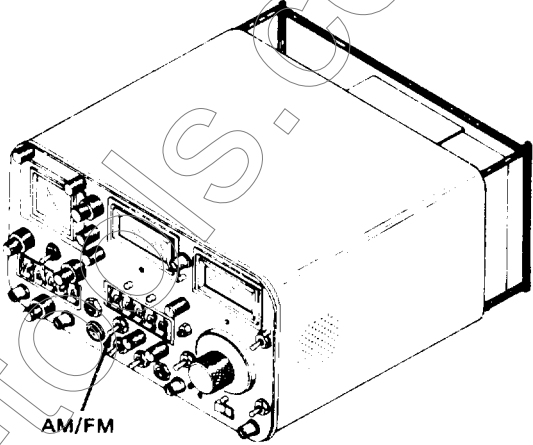
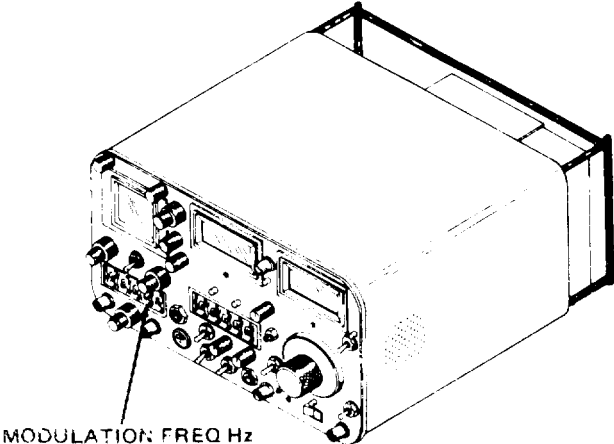
step	Procedure	Illustration
1	Return controls and indicators to the settings listed in table 4-3. Then generate an rf signal by performing steps of table 4-4.	
2	Place AM/FM switch to FM.	 <p>The illustration shows a perspective view of the RF signal generator. A line points from the label 'AM/FM' to a switch on the front panel.</p>
3	Set MODULATION FREQ Hz thumb-wheels to desired tone modulation frequency.	 <p>The illustration shows a perspective view of the RF signal generator. A line points from the label 'MODULATION FREQ Hz' to a set of thumb-wheels on the front panel.</p>

Table 4-6. RF Signal Generator operating Instructions for FM RF Signals -- Continued


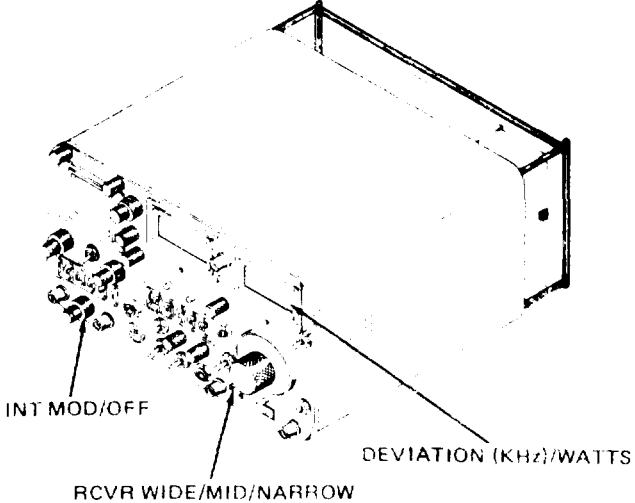
step	Procedure	Illustration
4	<p>Place DEV/PWR control to desired deviation range (2, 6, or 20 KHz).</p>	 <p>DEV/PWR</p>
5	<p>Rotate INT MOD/OFF control cw while observing DEVIATION (KHz)/WATTS meter until meter indicates desired deviation on appropriate scale. The AN/GRM-114 is now generating frequency modulated rf signals within the desired deviation range.</p> <p style="text-align: center;"><b>NOTE</b></p> <p>If deviation is above 5 kHz, place RCVR WIDE/MID/NARROW switch to MID or WIDE position.</p> <p>Signals at a 1-kHz rate with more than 5-kHz deviation must be monitored with RCVR WIDE/MID/NARROW switch in MID position.</p> <p>Signals modulated above 2 kHz should be monitored with RCVR WIDE/MID/NARROW switch in WIDE position. Note residual modulation indication due to noise on DEVIATION (KHz)/WATTS meter; add this value to desired value.</p>	 <p>INT MOD/OFF</p> <p>RCVR WIDE/MID/NARROW</p> <p>DEVIATION (KHz)/WATTS</p>



Table 4-6. RF Signal Generator Operating Instructions for FM R F Signals — Continued

Step	Procedure	Illustration
6	Emergency operating procedures. For emergency operating procedures (battery weakening) refer to table 4-2.	
7	Stopping procedures. Refer to the stopping procedures in table 4-2.	

4-5. Oscilloscope Operating Instructions.

**CAUTION**

Do not apply inure than 200 V (peak-to-]leak) to the SCOPE INPUT connector. If an oscilloscope probe is used to apply a signal from a UUT to the SCOPE INPUT connector, attach the ground lead of the probe to UUT ground.

Table 4-7 lists the initial adjustments and control settings (figure 4-3) necessary to display a trace

on the oscilloscope. Table 4-8 lists the operating instructions.

**NOTE**

To apply power to the AN/GRM-114, refer to the instructions in paragraph 4-4.

Warm-Up time of the crt is approximately 30 seconds from a "cold" startup. The trace will not appear until the crt warms up.

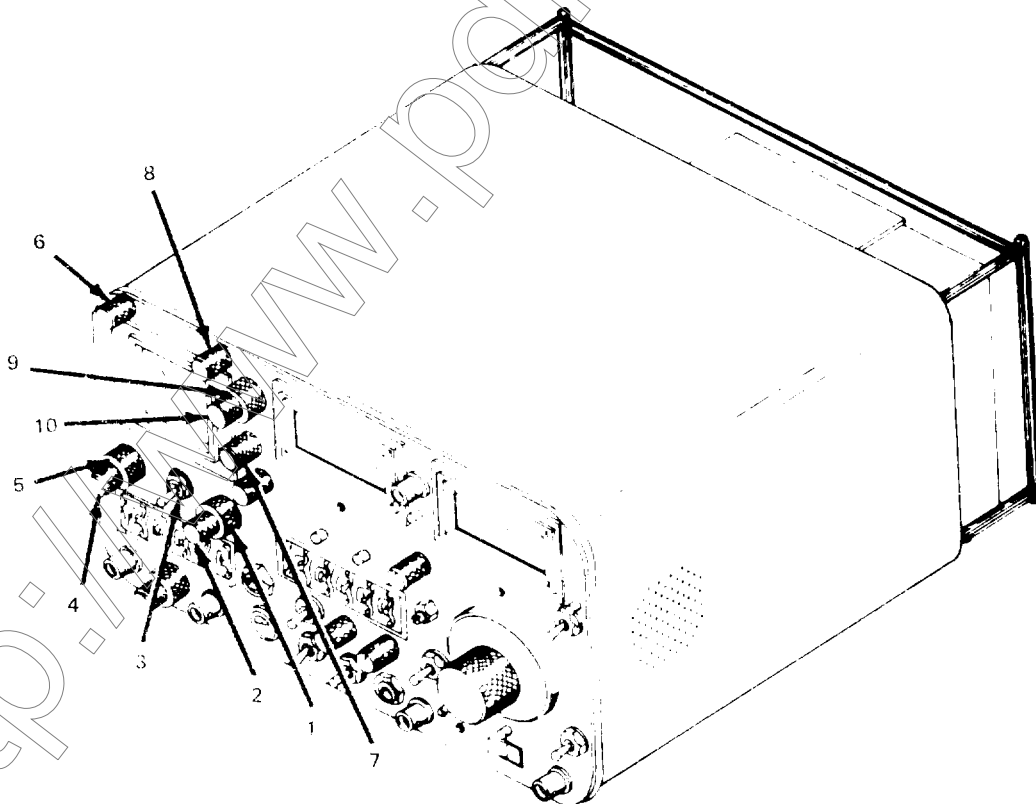


Figure 4-3. Oscilloscopic controls, indicators, and connectors

Table 4-7. Oscilloscope Initial Adjustments and Control Settings

Figure 4-3 Reference No.	Control, indicator or connector	Initial adjustment or setting
1	SWEEP control	1 ms
2	SWEEP vernier control	Fully cw, detent (in CAL)
3	AC/OFF/DC switch	AC
4	EXT V/DIV vernier control	Fully cw, detent (in CAL)
5	EXT V/DIV control	10 V/DIV
6	INTENSITY control	Midrange
7	HORIZ control	Midrange
8	FOCUS control	Midrange
9	VERT control	Midrange
10	ANALY DISPR/OFF control	Fully ccw, detent (OFF)

Table 4-8. Oscilloscope Operating Procedures

Step	Procedure	Illustration
1	<p style="text-align: center;"><b>CAUTION</b></p> <p>Do not exceed 200 V (peak-to-peak) into the SCOPE IN connector. When applying power to oscilloscope or spectrum analyzer through PWR/OFF/BATT switch or AC/DC/OFF switch, make sure INTENSITY control is at moderate (left) position.</p> <p>Adjust INTENSITY control cw and FOCUS control appropriately to obtain a sharp visible trace display.</p>	<p>The illustration shows a close-up of the oscilloscope's control panel. Three labels with arrows point to specific controls: 'INTENSITY' points to a knob on the left, 'FOCUS' points to a knob in the center, and 'CRT DISPLAY' points to the screen area on the right.</p>

Table 4-8. Oscilloscope Operating Procedures – Continued

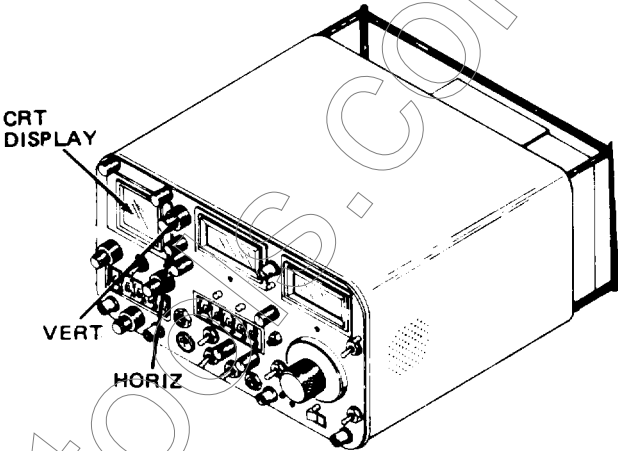
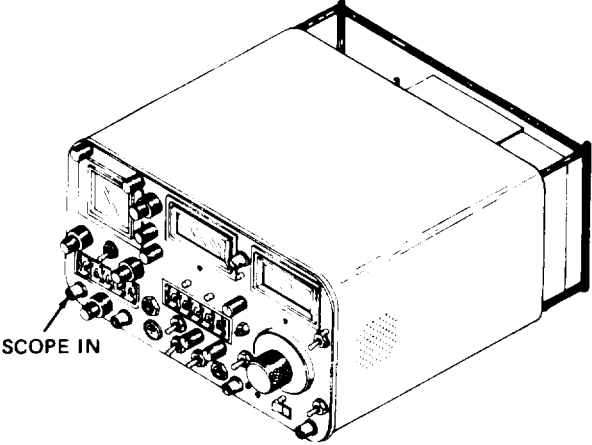
Step	Procedure	Illustration
2	Adjust VERT control and HORIZ control to center scope trace over major horizontal axis of crt.	 <p>This illustration shows a perspective view of an oscilloscope. Three labels with leader lines point to specific controls on the front panel: 'CRT DISPLAY' points to the screen area, 'VERT' points to a vertical control knob, and 'HORIZ' points to a horizontal control knob.</p>
3	Connect signal stimuli to SCOPE IN connector.	 <p>This illustration shows a perspective view of the same oscilloscope. A label 'SCOPE IN' with a leader line points to a specific input connector on the front panel.</p>

Table 4-8. Oscilloscope Operating Procedures -- Continued

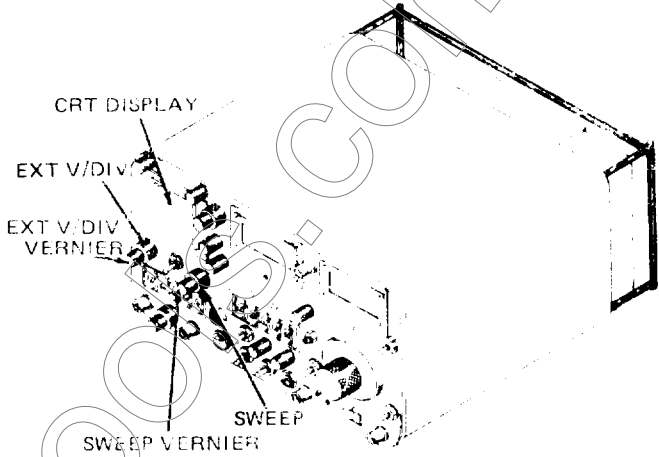
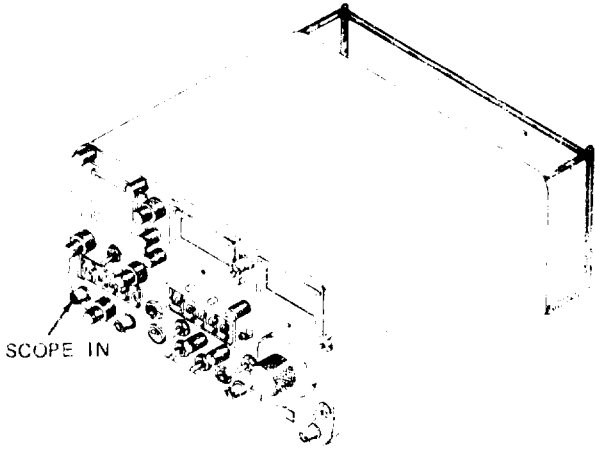
Step	Procedure	Illustration
4	<p>Adjust SWEEP control, EXT V/DIV control and SWEEP vernier control to obtain a stable waveform.</p> <p style="text-align: center;"><b>NOTE</b></p> <p>EXT V/DIV vernier control must remain in CAL position (fully cw, detent).</p>	 <p>The illustration shows a perspective view of the oscilloscope's control panel. Labels with leader lines point to the following controls: CRT DISPLAY (top left), EXT V/DIV (middle left), EXT V/DIV VERNIER (middle left, below EXT V/DIV), SWEEP (middle right), and SWEEP VERNIER (middle right, below SWEEP).</p>
5	<p>Disconnect the signal stimuli from the SCOPE IN connector.</p>	 <p>The illustration shows a perspective view of the oscilloscope's control panel. A label with a leader line points to the SCOPE IN connector located on the left side of the panel.</p>

Table 4-8. Oscilloscope Operating Procedures – Continued

Step	Procedure	Illustration
6	Emergency operating procedures. Refer to the emergency operating procedures (battery weakening) in table 4-2.	
7	Stopping procedures  (a) Set AC/DC/OFF switch to OFF position.  (b) For further stopping procedures, refer to table 4-2.	

4-6. Receiver Operating Instructions. Table 4-9 lists the initial adjustments and control settings (figure 4-4) necessary to receive signals. Table 4-10 lists the operating instructions.

NOTE

To apply power to the AN/GRM-114, refer to the instructions in paragraph 4-3.

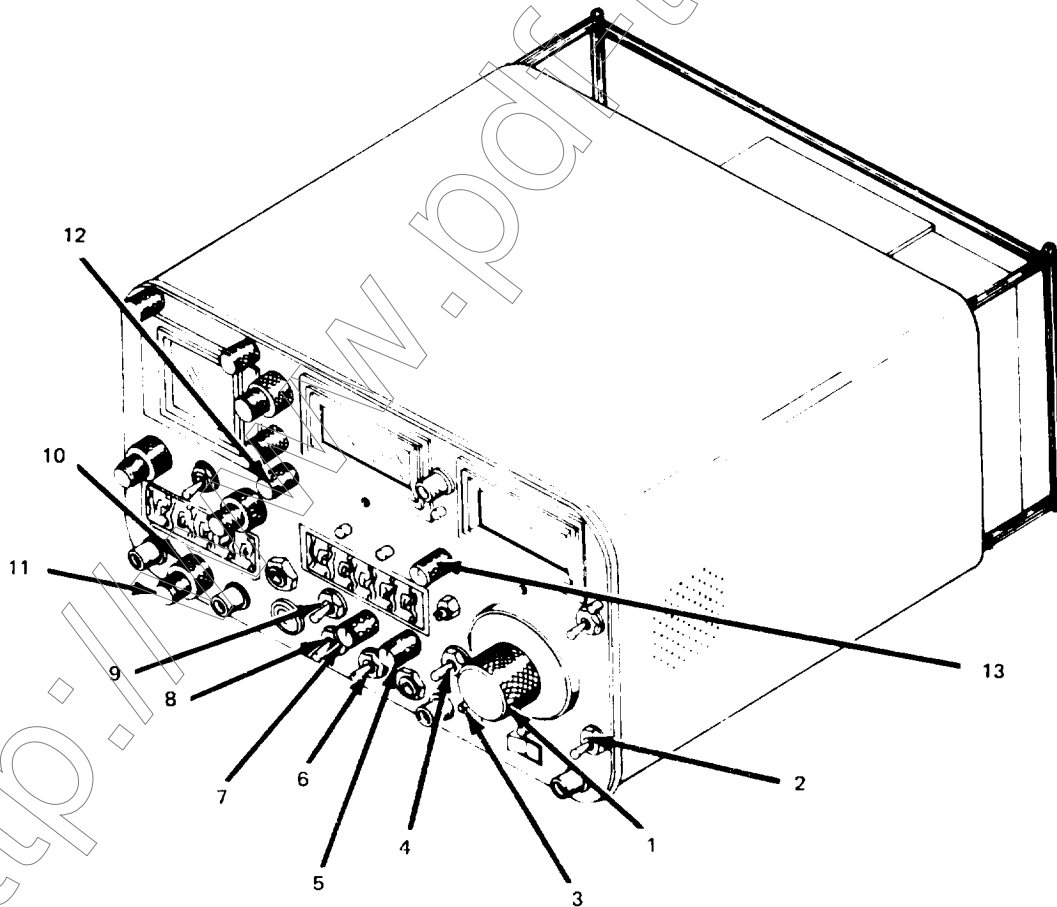


Figure 4-4. Receiver controls, indicators, and connectors

Table 4-9. Initial Adjustments and Control Settings

Figure 4-4 Reference No.	Control, indicator or connector	Initial adjustment or setting
1	RF LEVEL/BFO INJECTION dial	Fully ccw
2	AUTO/OFF/ZERO, BATT switch	AUTO
3	RCVR WIDE/MID/NARROW switch	WIDE
4	GEN/RCVR switch	RCVR
5	SQUELCH/OFF control	Fully ccw, short of detent
6	INT MOD/RCVR switch	RCVR
7	VOL control	Fully ccw
8	BFO/OFF switch	OFF
9	AM/FM switch	AM or FM depending on mode of signal to be received.
10	INT MOD/OFF control	Fully ccw, detent (OFF)
11.	1 KHz INT MOD/OFF control	Fully ccw, detent (OFF)
12	1.5/5/15 KHz control	15 KHz
13	DEV,/PWR control	SIG

Table 4-10. Receiver Operating Instructions

Step	Procedure	Illustration
	<p style="text-align: center;"><b>CAUTION</b></p> <p>Do not connect a transmitter to the ANT INPUT connector. Connect only an external antenna to the ANT INPUT connector. Do not exceed 200 V (peak-to-peak) into the SCOPE IN connector.</p> <p style="text-align: center;">NOTE</p> <p>Remove any static discharge from an unterminated antenna before connecting it to the AN/GRM-114.</p>	

Table 4-10. Receiver Operating Instructions – Continued

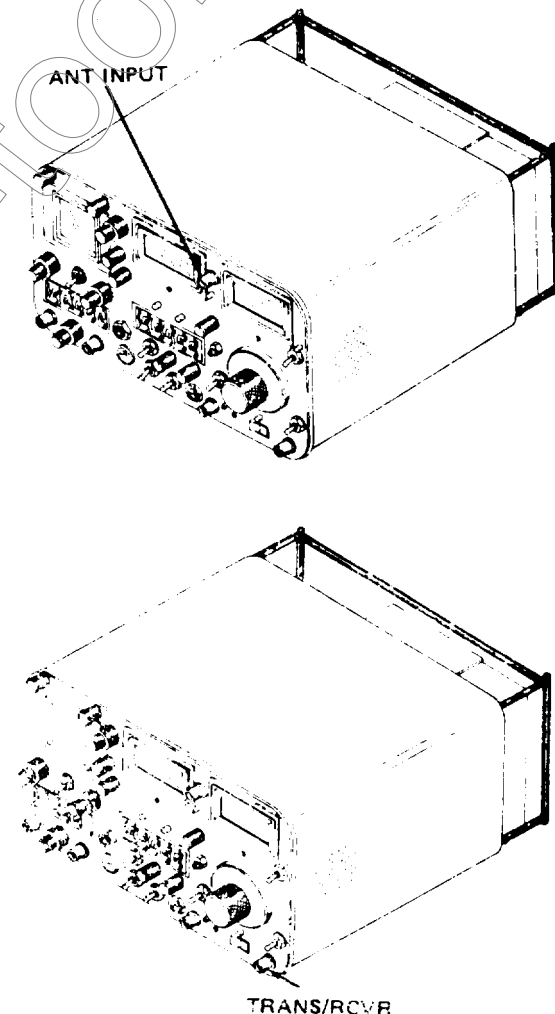
step	Procedure	Illustration
1	<p style="text-align: center;"><b>CAUTION</b></p> <p>Maximum continuous input to this connector must not exceed 0.25 W.</p> <p>Maximum input is -30 dBm for proper spectrum analyzer operation (signals above -30 dBm may cause spurious signals to be generated and displayed by AN/GRM-114),</p> <p>Select one of the following methods of signal reception:</p> <p>(a) External antenna</p> <p>Connect external antenna to ANT INPUT connector for "off-the-air" monitoring. Proceed to step 3.</p> <p style="text-align: center;"><b>CAUTION</b></p> <p>Do not apply more than 20 watts of continuous input, to TRANS/RCVR connector.</p> <p>(b) Direct Cable Connection from UUT</p> <p>Connect cable from UUT to TRANS/RCVR connector.</p> <p>Maximum operating "ON" time for measurement of transmitter output using TRANS/RCVR connector is:</p> <p>10 seconds at 100 W, 15% duty cycle,                  20 seconds at 50 W, 30% duty cycle, or                  2 minutes at 30 W, 50% duty cycle.</p>	
2	<p>Apply power to UUT (if applicable)</p>	

Table 4-10. Receiver Operating Instructions – Continued

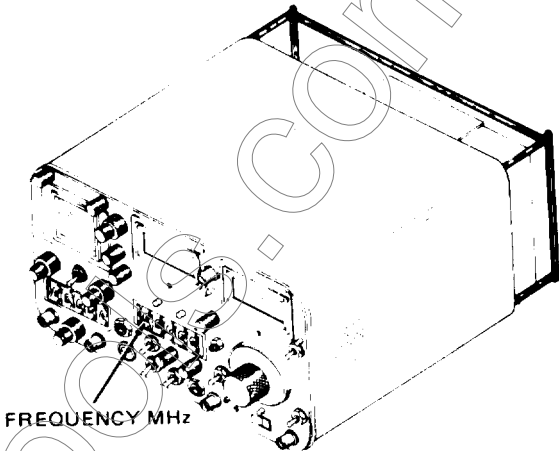
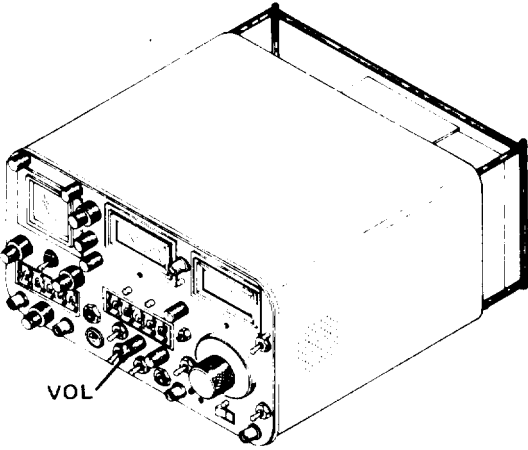
Step	Procedure	Illustration
3	Set FREQUENCY MHz thumbwheels to frequency of signal to be received.	 <p>The illustration shows a perspective view of the receiver's front panel. A callout line points to a set of thumbwheels labeled "FREQUENCY MHz".</p>
4	Adjust VOL control to a comfortable listening level.	 <p>The illustration shows a perspective view of the receiver's front panel. A callout line points to a knob labeled "VOL".</p>



Table 4-10. Receiver Operating Instructions – Continued

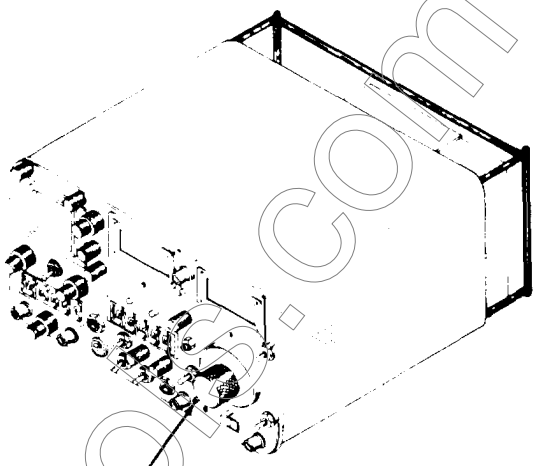
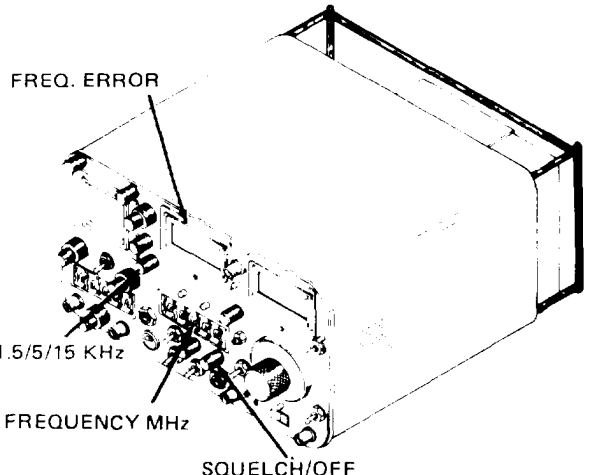
Step	Procedure	Illustration
5	<p>If an area of the spectrum is being monitored where frequency channels are packed closely together, bandwidth of signal may be reduced by placing RCVR WIDE/MID/NARROW switch to MID or NARROW setting.</p> <p>When monitoring FM signals, the NARROW setting of RCVR WIDE/MID/NARROW switch will not accommodate greater than 5-kHz FM deviation of most FM transmitters. If FM deviation is more than <math>\pm 5</math> kHz, place RCVR WIDE/MID/NARROW switch to MID position.</p> <p style="text-align: center;"><b>NOTE</b></p> <p>Ensure that proper bandpass width has been selected on RCVR WIDE/MID/NARROW switch. Too high a bandpass will cause higher noise reading. Too low a bandpass will cause distortion.</p>	 <p style="text-align: center;">RCVR WIDE/MID/NARROW</p>
6	<p>Fine tune the receiver to center frequency (within <math>\pm 100</math> Hz) as follows:</p> <p>(a) If <b>FREQ. ERROR</b> meter appears centered at zero, proceed to step 6 (b); if meter needle is not centered, increase or decrease settings of <b>FREQUENCY MHz</b> thumbwheels in 10-kHz and 1-kHz steps to center needle as closely as possible to zero, then proceed to step 6 (b).</p> <p>(b) Rotate 1.5/5/15 KHz control to 5 KHz position. If <b>FREQ. ERROR</b> meter remains centered at zero, proceed to step 6 (c); if meter needle deviates from zero, increase or decrease settings of <b>FREQUENCY MHz</b> thumbwheels in 1-kHz steps to center needle as closely as possible to zero, then proceed to step 6(c).</p>	 <p style="text-align: center;">FREQ. ERROR</p> <p style="text-align: center;">1.5/5/15 KHz</p> <p style="text-align: center;">FREQUENCY MHz</p> <p style="text-align: center;">SQUELCH/OFF</p>

Table 4-10. Receiver Operating Instructions -- Continued

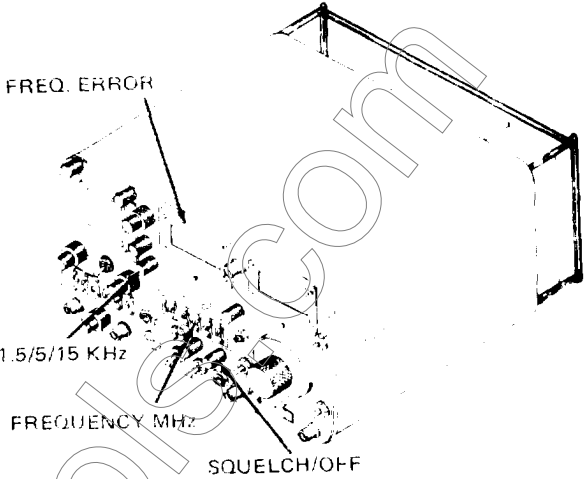
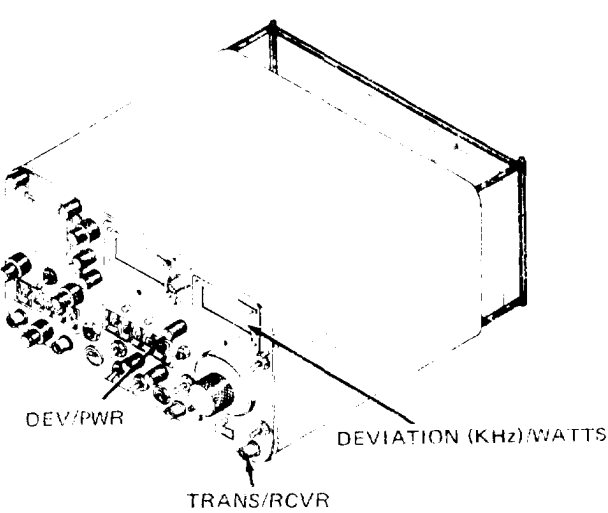
Step	Procedure	Illustration
6 (Cent)	<p>(c) Rotate 1.5/5/15 KHz control to 1.5 KHz position. Increase or decrease settings of FREQUENCY MHz thumbwheels in 100-Hz steps until meter needle is centered at zero (within 1 minor division on meter scale). Setting of FREQUENCY MHz thumbwheels now reflect exact frequency of received signal.</p>	 <p>FREQ. ERROR</p> <p>1.5/5/15 KHz</p> <p>FREQUENCY MHz</p> <p>SQUELCH/OFF</p>
7	<p>If received signal is being monitored through a direct cable connection at TRANS/RCVR connector, rotate DEV/PWR control to WATTS x 10. If DEVIATION (KHz) WATTS meter reading is under 10 watts (on red scale), rotate DEV/PWR control to WATTS x 1.</p>	 <p>DEV/PWR</p> <p>DEVIATION (KHz)/WATTS</p> <p>TRANS/RCVR</p>

Table 4-10. Receiver Operating Instructions— Continued

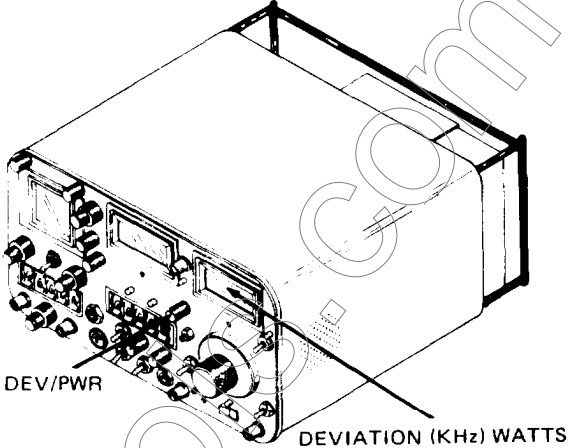
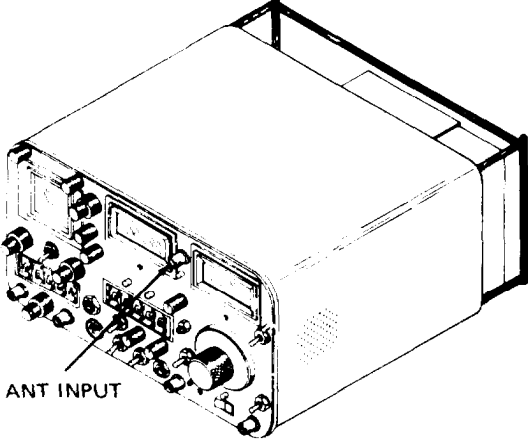
Step	Procedure	Illustration
8	<p>Output power of UUT can now be measured on red scale of DEVIATION (KHz) /WATTS meter,</p> <p style="text-align: center;">NOTE</p> <p>For signals received “off-the-air”, a representation of relative signal strength can be determined by observing DEVIATION (KHz) /WATTS meter needle deflection (with DEV/PWR control in SIG position). As signal strength increases, the meter needle deflection will increase toward the right of meter scale. For exact measurement of “off-the-air” signal strength, refer to procedures for measuring signal strength under spectrum analyzer operating instructions.</p>	
9	<p>Emergency operating procedures.</p> <p>(a) Broken antenna. Remove antenna from ANT INPUT connector. Remove insulation to expose wire. Butt the two separated ends together and secure with any nonconductive material.</p> <p>(b) Jammed signals. It is likely that under real or simulated tactical conditions the receiver will be jammed by the enemy. Enemy jamming is done by transmitting a strong signal on the same frequency as that used for communication, making it difficult or impossible to receive the desired signal. Unusual noise or signal strength indications without messages may be caused by enemy jamming, signals from a friendly station, or noise from a local source; or the receiver may be defective. To determine whether or not the interference is originating in the</p>	

Table 4-10. Receiver Operating Instructions -- Continued

Step	Procedure	Illustration
9 (Cont)	<p>AN/GRM-114, disconnect and remove the antenna. If the interference continues, the AN/GRM-114 is defective.</p> <p>Enemy jamming signals may be typed as continuous wave or modulated. A jamming signal may be intended to block a single frequency. This is called spot jamming. The enemy may use one or several transmitters to jam a block or band of frequencies. This method is called barrage jamming. Following are several types of jamming signals:</p> <p>(1) CW (continuous wave) jamming. CW jamming is transmitted as a steady carrier. This signal beats with another signal and produces a steady tone or in some cases, a quieting effect. CW jamming signals may also be keyed by using a random on-and-off signal or using actual code characters keyed to the same rate or a little faster than the signal being received.</p> <p>(2) Modulated jamming. Modulated jamming signals may consist of noise, laughter, singing, music, various tone, or almost any unusual sound, or it may be a combination of these sounds. Various types of modulated jamming signals are explained below.</p> <p>(a) <i>Spark</i>. This is one of the simplest, most effective, and most easily produced jamming signals. This type of signal sounds very rough, raspy, and sometimes like an operating electric motor with sparking brushes. The signal is very broad; therefore, it will interfere with a large number of communication channels.</p> <p>(b) <i>Sweep-through</i>. This signal is the result of sweeping or moving a carrier back and forth at a slow or rapid rate. The numerous signals of varying amplitude and frequency</p>	

Table 4-10. Receiver Operating Instructions – Continued

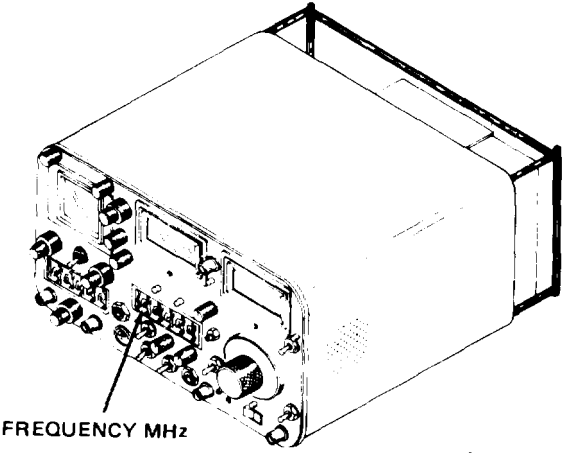
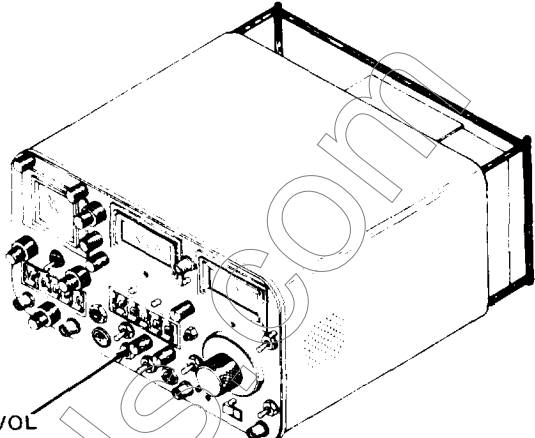
Step	Procedure	Illustration
9 (Cent	<p>produce a sound like that of a low-flying airplane passing overhead. This type of jamming is effective over a broad range of frequencies. When it is varied rapidly, it is effective against all types of voice signals.</p> <p>(c) Stepped tones or bagpipes. This signal usually consists of several separate tones. The tones are transmitted in the order of first increasing and then decreasing pitch, repeated over and over. The audible effect is like the sound of a Scottish bagpipe.</p> <p>(d) Noise. Noise is random both in amplitude and frequency. It produces a sound similar to that heard when a receiver is not tuned to a station and the VOL control is turned to maximum.</p> <p>(e) Gulls. This signal consists of a quick rise and slow fall of a variable audio frequency. The sound is similar to the cry of the sea gull.</p> <p>(f) Tone. This signal consists of a single audio frequency of unvarying tone. It produces a steady howl. Another method of tone jamming is to vary it slowly. This produces a howling sound of varying pitch.</p> <p>(3) Antijamming procedures. When it is determined that the incoming signal is being jammed, notify your immediate superior officer and continue to operate the equipment. To provide maximum intelligibility of jammed signals, follow one or more of the operational procedures given in the following steps. If these procedures do not provide sufficient signal separation for satisfactory operation, change to an alternate frequency.</p> <p>(a) Detune FREQUENCY MHz thumbwheel switches by several increments on either side of received signal.</p>	 <p>FREQUENCY MHz</p>

Table 4-10. Receiver Operating Instructions – Continued

Step	Procedure	Illustration
9 (Cent	<p>This may cause some separation of received signal and jamming signal.</p> <p>(b) Vary VOL control. This may reduce jamming signal enough to permit weak signal to be heard.</p> <p>(c) Refer to table 4-2 for further emergency operating procedures (battery weakening).</p>	
10	<p>Stopping procedures. Refer to the stopping procedures in table 4-2.</p>	

4-7. Spectrum Analyzer Operating Instructions. Table 4-11 lists the initial adjustments and control settings (figure 4-5) necessary to operate the spectrum analyzer. Table 4-12 lists the operating instructions for use of the spectrum analyzer. To detect spurious signals with the spectrum analyzer refer to table 4-13.

NOTE

To apply power to the AN/GRM-114, refer to the instructions in paragraph 4-3.

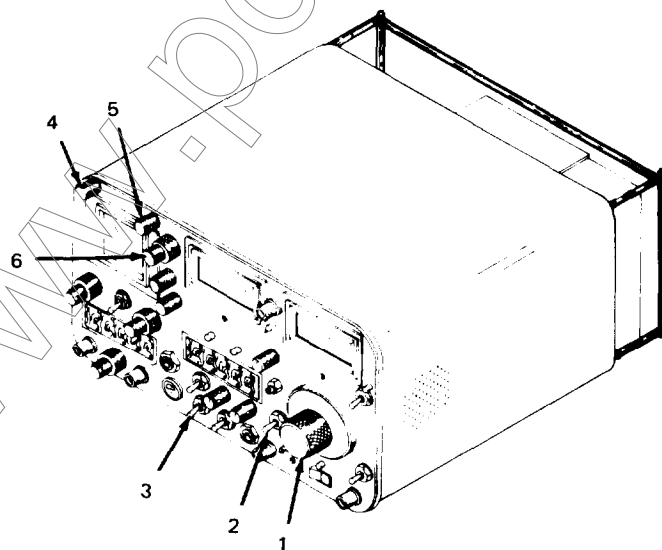


Figure 4-5. Spectrum analyzer controls, indicators, and connectors

Table 4-1. Initial Adjustments and Control Settings

Figure 4-5 Reference No.	Control, indicator, or connector	Initial adjustment or setting
1	RF LEVEL/BFO INJECTION dial	Fully ccw
2	GEN/RXV R switch	RCVR
3	BFO/OFF switch	OFF
4	INTENSITY control	Midrange
5	FOCUS control	Midrange
6	ANALY DISPR/OFF control	Fully cw

Table 4-12. Spectrum Analyzer Operating Instructions

Step	Procedure	Illustration
	<p><b>CAUTION</b></p> <p>Do not exceed 200 V (peak-to-peak) into the SCOPE IN connector.</p> <p><b>NOTE</b></p> <p>Remove any static discharge from anm unterminated antenna before connecting it to the AN/GRM-114. Perform the following steps to measure signal strength.</p> <p><b>CAUTION</b></p> <p>Maximum continuous input to this connector must not exceed 0.25 W.</p> <p>Maximum input is -30 dBm for proper spectrum analyzer operation (signals above -30 dBm may cause spurious signals to be generated and displayed by AN/GRM-114).</p>	
1	Connect signal stimuli to ANT INPUT connector-, or connect transmitter output to TRANS/RCVR connector.	

Table 4-12. Spectrum Analyzer Operating Instructions – Continued

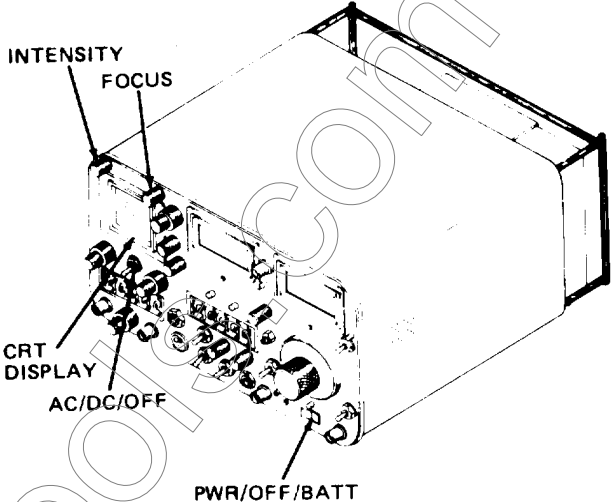
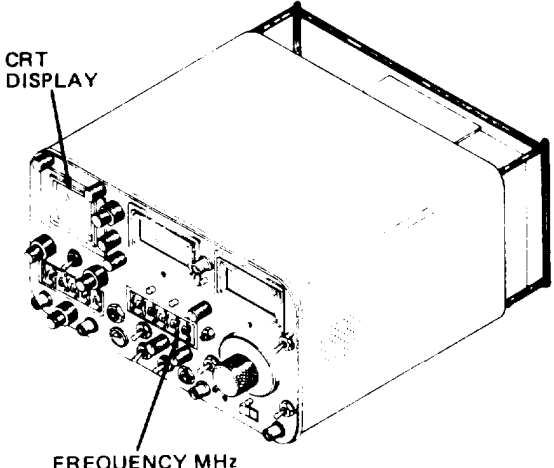
Step	Procedure	Illustration
	<p style="text-align: center;"><b>CAUTION</b></p> <p>When applying power to the oscilloscope or spectrum analyzer from PWR/OFF/BATT switch or AC/DC/OFF switch, make sure INTENSITY control is in moderate (left) position.</p>	
2	<p>Adjust INTENSITY control cw and FOCUS control appropriately to obtain a sharp visible trace display.</p> <p style="text-align: center;">NOTE</p> <p>Warmup time of crt is approximately 30 seconds from a "cold" startup; trace display will not become visible until crt achieves warmup.</p>	 <p>This illustration shows the control panel of the spectrum analyzer. Labels with leader lines point to the INTENSITY control knob, the FOCUS control knob, the CRT DISPLAY area, the AC/DC/OFF switch, and the PWR/OFF/BATT switch.</p>
3	<p>Adjust FREQUENCY MHz thumbwheels so that desired signal is aligned along major vertical axis of crt. Signal to be measured is now on center frequency.</p>	 <p>This illustration shows the control panel of the spectrum analyzer. Labels with leader lines point to the CRT DISPLAY area and the FREQUENCY MHz thumbwheels.</p>



Table 4-12. Spectrum Analyzer Operating Instructions -- Continued

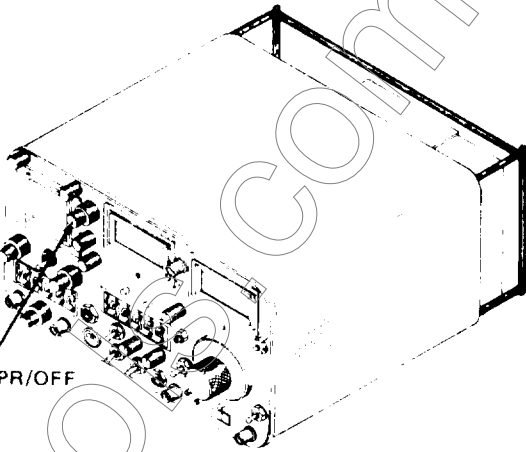
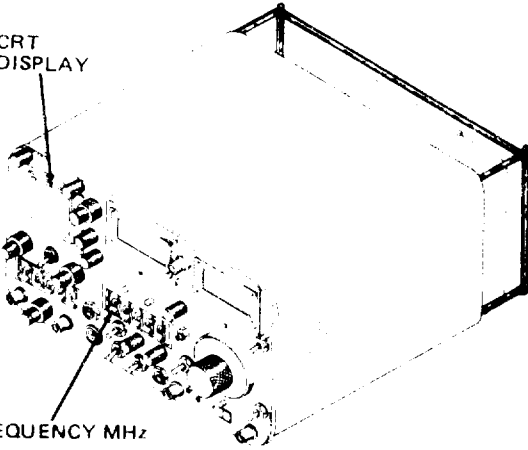
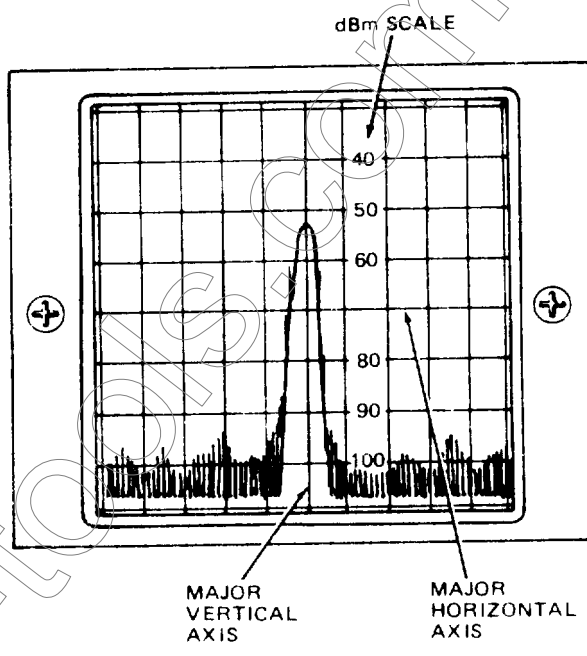
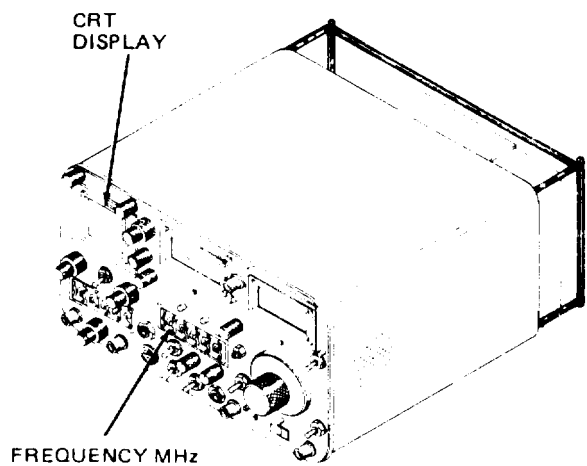
Step	Procedure	Illustration
4	Rotate ANALY DISPR/OFF control Fully ccw, short of detent position	 <p>ANALY DISPR/OFF</p>
5	Again adjust FREQUENCY MHz thumb- wheels so desired signal is aligned along major vertical axis on crt.	 <p>CRT DISPLAY</p> <p>FREQUENCY MHz</p>

Table 4-12. Spectrum Analyzer Operating Instructions – Continued

step	Procedure	Illustration
6	Measure and record peak of displayed signal along vertical dB scale.	
7	Offset displayed signal to either side of major vertical axis by two major graticule divisions by increasing or decreasing settings of FREQUENCY MHz thumb-wheels.	

<http://www.pdf-t.com>

Table 4-12. Spectrum Analyzer Operating Instructions — Continued

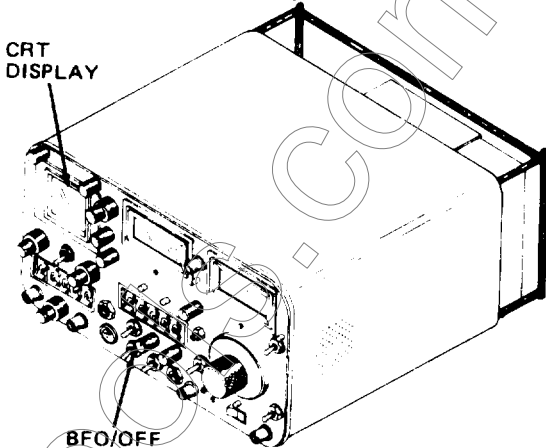
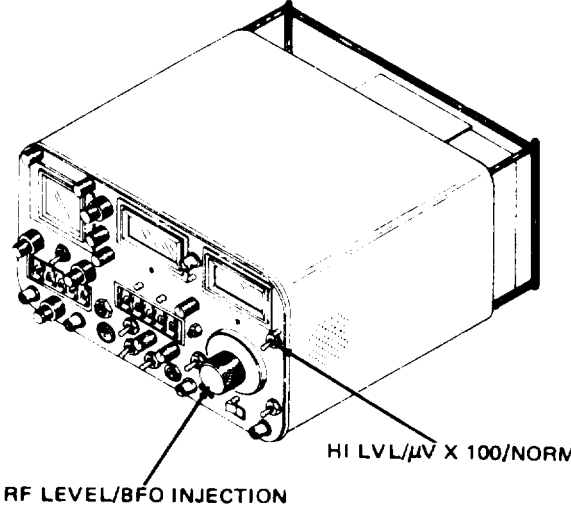
Step	Procedure	Illustration
8	Place BFO/OFF switch to BFO.	 <p>This illustration shows a perspective view of the spectrum analyzer. A label 'CRT DISPLAY' points to the screen on the left side of the front panel. Another label 'BFO/OFF' points to a switch located on the front panel, below the CRT display area.</p>
9	<p>Rotate RF LEVEL/BFO INJECTION dial cw so that injected bfo signal is the same amplitude as signal under test.</p> <p style="text-align: center;"><b>NOTE</b></p> <p>If injected bfo signal cannot be raised to amplitude of signal under test, set HI LVL/<math>\mu</math>V X 100/NORM switch to <math>\mu</math>V X 100. Again rotate RF LEVEL/BFO INJECTION dial cw until injected bfo signal matches amplitude of signal under test.</p>	 <p>This illustration shows a perspective view of the spectrum analyzer. A label 'RF LEVEL/BFO INJECTION' points to a large dial on the front panel. Another label 'HI LVL/<math>\mu</math>V X 100/NORM' points to a switch on the front panel, located to the right of the RF LEVEL/BFO INJECTION dial.</p>

Table 4-12. Spectrum Analyzer Operating Instructions – Continued

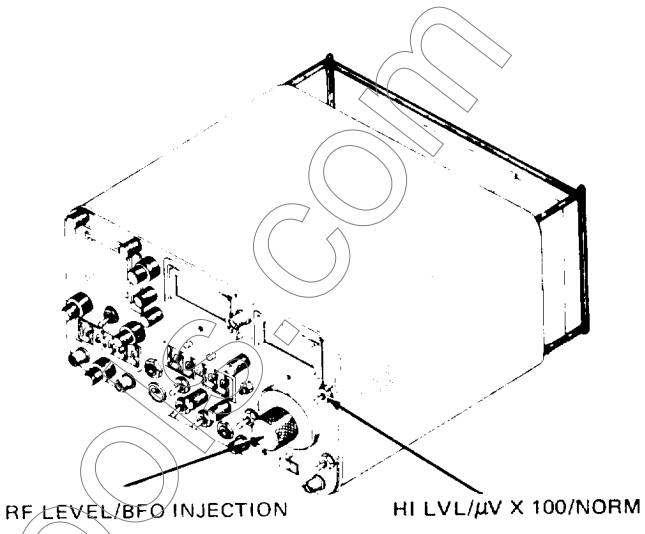
Step	Procedure	Illustration
10	<p>Read signal strength of signal under test on <math>\mu\text{V}</math> or dBm scale of RF LEVEL/BFO INJECTION dial as follows:</p> <p>(a) If HI LVL/<math>\mu\text{V}</math> X 100/NORM switch is at NORM, setting of RF LEVEL/BFO INJECTION dial represents measured signal strength.</p> <p>(b) If HI LVL/<math>\mu\text{V}</math> X 100/NORM switch is at <math>\mu\text{V}</math> X 100, add +40 dBm to reading of RF LEVEL/BFO INJECTION dial on dBm scale to obtain true signal strength in dBm. For equivalent signal strength in <math>\mu\text{V}</math>, multiply <math>\mu\text{V}</math> setting of RF LEVEL/BFO INJECTION dial by 100.</p>	 <p>The illustration shows a perspective view of the Spectrum Analyzer's front panel. Two specific controls are highlighted with leader lines: the 'RF LEVEL/BFO INJECTION' dial on the left and the 'HI LVL/<math>\mu\text{V}</math> X 100/NORM' switch on the right.</p>

Table 4-13. Spectrum Analyzer Operating Instructions for Spurious Signal Detection

Step	Procedure	Illustration
1	<p>Return controls and indicators to the settings listed in table 4-11.</p> <p><b>NOTE</b></p> <p>Remove any static discharge from an unterminated antenna before connecting to the AN/GRM-114.</p>	

Table 4-13. Spectrum Analyzer Operating Instructions for Spurious Signal Detection – Continued

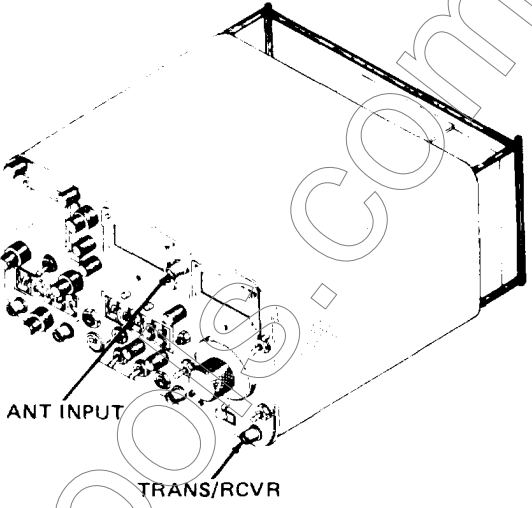
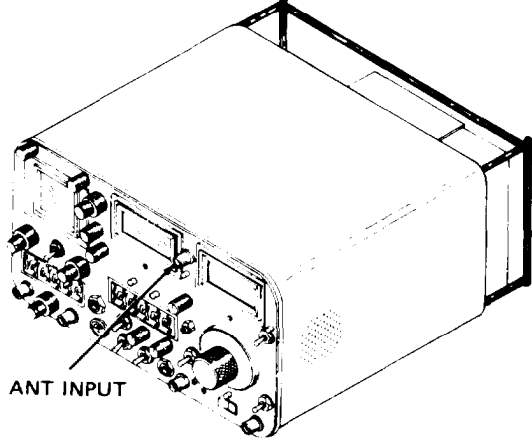
Step	Procedure	Illustration
1 (Cont)	<p style="text-align: center;"><b>CAUTION</b></p> <p>Do not connect transmitter to ANT INPUT connector. Connect only external antenna to ANT INPUT connector.</p> <p>Maximum continuous input to ANT INPUT connector must not exceed 0.25 W.</p> <p>Maximum input to ANT INPUT connector is <math>-30</math> dBm for proper spectrum analyzer operation (signals above <math>-30</math> dBm may cause spurious signals to be generated and displayed by AN/GRM-114).</p> <p>If signal is to be monitored through a UUT via a direct cable connection to TRANS/RCVR connector, do not apply more than 20 watts of CONTINUOUS input to TRANS/RCVR connector. Maximum operating "ON" time for measurement of transmitter output using TRANS/RCVR connector is:</p> <p>10 seconds at 100 W, 15% duty cycle,                  20 seconds at 50 W, 30% duty cycle, or                  2 minutes at 30 W, 50% duty cycle.</p>	 <p>ANT INPUT</p> <p>TRANS/RCVR</p>
2	<p>Connect external antenna to ANT INPUT connector for "off-the-air" monitoring.</p>	 <p>ANT INPUT</p>

Table 4-13, Spectrum Analyzer Operating Instructions for Spurious Signal Detection--Continued

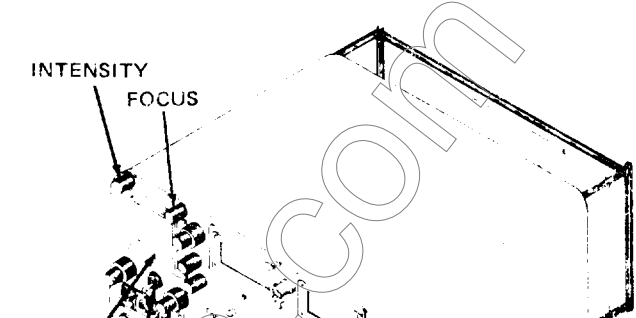

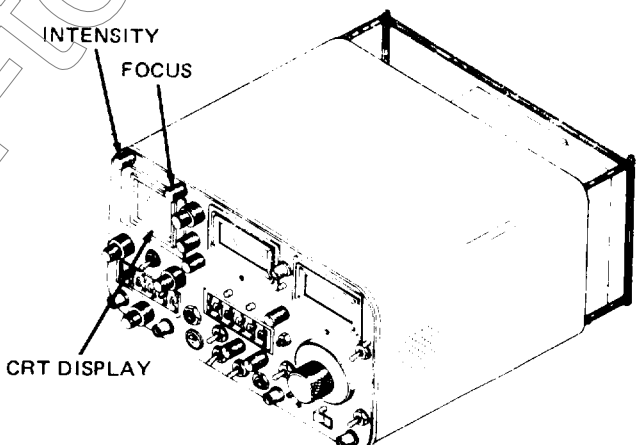
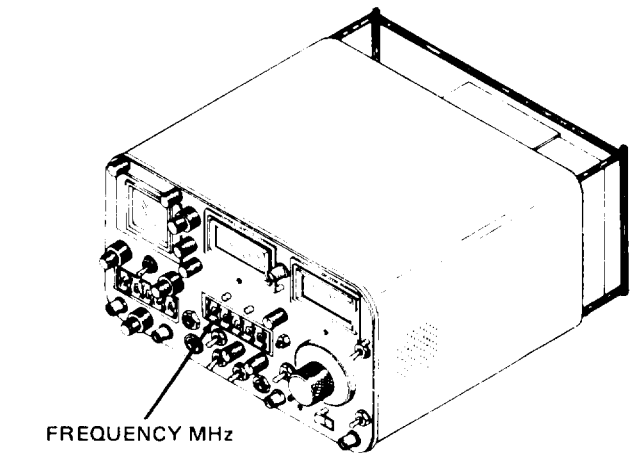
Step	Procedure	Illustration
3	<p>Apply power to UUT (if applicable).</p> <p style="text-align: center;"><b>CAUTION</b></p> <p>When applying power to spectrum analyzer or oscilloscope from PWR/OFF/BATT switch or AC/DC/OFF switch, make sure INTENSITY control is in moderate (left) position.</p>	 <p>INTENSITY FOCUS</p>
4	<p>Adjust INTENSITY control cw and FOCUS control appropriately for a sharp visible trace on crt.</p> <p style="text-align: center;"><b>NOTE</b></p> <p>Warmup time of crt is approximately 30 seconds from a "cold" startup; trace display will not become visible until crt achieves warmup.</p>	 <p>CRT DISPLAY AC/DC/OFF PWR/OFF/BATT</p>  <p>INTENSITY FOCUS</p>
5	<p>Set FREQUENCY MHz thumbwheels to desired center frequency.</p>	 <p>FREQUENCY MHz</p>

Table 4-13. Spectrum Analyzer Operating Instructions for Spurious Signal Detection – Continued

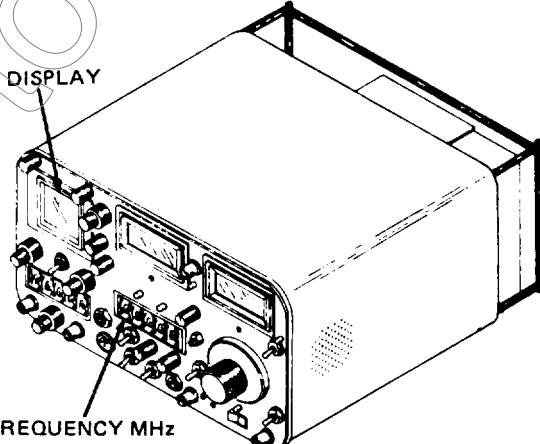
Step	Procedure	Illustration
6	<p>Momentarily remove and reapply power to UUT (or in case of a transmitter spectral purity check, key transmitter on and off), while carefully observing carrier signal and surrounding span for any spurious signals.</p> <p style="text-align: center;"><b>NOTE</b></p> <p><b>When interrupting power to UUT (or keying transmitter on and off ), certain momentary spikes which protrude above the noise level may appear. Disregard these momentary spikes; look for signals which remain constant in amplitude during this time.</b></p>	
7	<p>To determine origin of spurious signal, increase or decrease setting of 1 MHz and 100 kHz segments of FREQUENCY MHz thurnbwheels several times above or below center frequency.</p>	

Table 4-13. Spectrum Analyzer Operating Instructions for Spurious Signal Detection – Continued

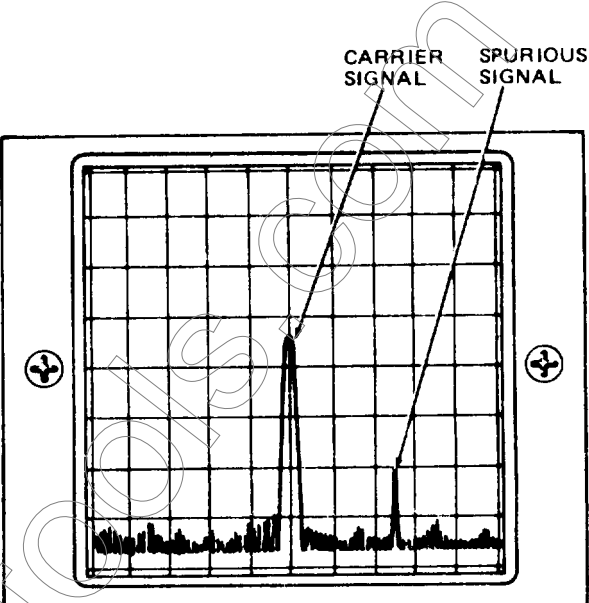
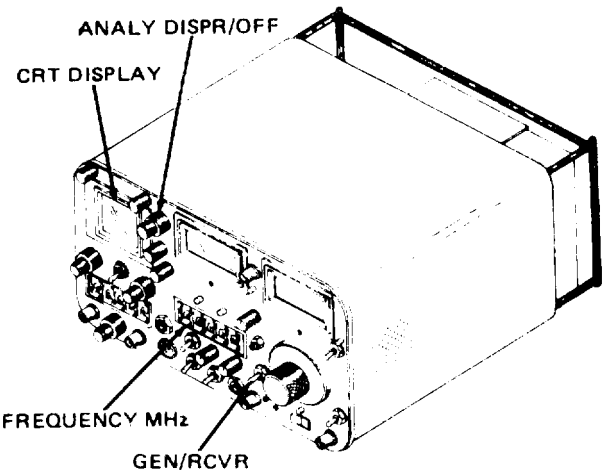
Step	Procedure	Illustration
7 (Cont)	<p>(a) If the spurious signal moves closer to or further away from carrier signal, the spurious signal is being produced by the AN/GRM-114 and thus can be disregarded.</p> <p>(b) If the spurious signal moves in same direction and same distance as carrier signal, the spurious signal is being produced by UUT.</p>	 <p>The illustration shows a spectrum analyzer's CRT display with a grid. Two distinct peaks are visible: a taller peak on the left labeled 'CARRIER SIGNAL' and a shorter peak on the right labeled 'SPURIOUS SIGNAL'. The baseline shows a noisy floor level.</p>
8	<p>To determine frequency of spurious signal, increase or decrease the setting of the FREQUENCY MHz thumbwheels while rotating ANALY DISPR/OFF control ccw until the spurious signal is aligned with major vertical axis. The setting of FREQUENCY MHz thumbwheels represents frequency of spurious signal.</p> <p><b>NOTE</b></p> <p>ANALY DISPR/OFF, control should be fully ccw, short of detent when final frequency reading is taken.</p> <p>To verify actual center of AN/GRM-114 spectrum analyzer, place GEN/RCVR switch to GEN position and observe generated signal:</p>	 <p>The illustration shows the physical spectrum analyzer unit from a three-quarter perspective. Labels point to the 'ANALY DISPR/OFF' control knob on the top panel, the 'CRT DISPLAY' window, the 'FREQUENCY MHz' thumbwheels on the front panel, and the 'GEN/RCVR' switch on the front panel.</p>



Table 413. Spectrum Analyzer Operating Instructions for Spurious Signal Detection – Continued

Step	Procedure	Illustration
8 (Cont)	<p>(a) If generated signal is aligned with major vertical axis, frequency of detected spurious signal is equal to setting of FREQUENCY MHz thumbwheels.</p> <p>(b) If generated signal is not centered over major vertical axis, note position of generated signal on crt graticule; place GEN/RCVR switch to RCVR and increase or decrease setting of FREQUENCY MHz thumbwheels to align spurious signal to same position to which the generated signal was previously aligned. The setting of FREQUENCY MHz thumbwheels represents frequency of detected spurious signal.</p>	
9	<p>Emergency operating procedures. Refer to the emergency operating procedures in step 9 of table 4-10 and in table 4-2.</p>	
10	<p>Stopping procedures. Refer to the stopping procedures in table 4-2.</p>	

4-8. Audio Generator Operating Instructions. When the AN/GRM-114 is used as an audio generator, the operation can be accomplished by either the use of the MM-100 to measure the audio signal level and match the impedance of the UUT or through the use of the oscilloscope as the audio signal level monitor. Therefore, two procedures

are presented. Table 4-14 lists the initial adjustments and control settings (figure 4-6) necessary to generate an audio signal. Table 4-15 lists the operating instructions using the MM-100 and table 4-16 lists the operating instructions using the oscilloscope.

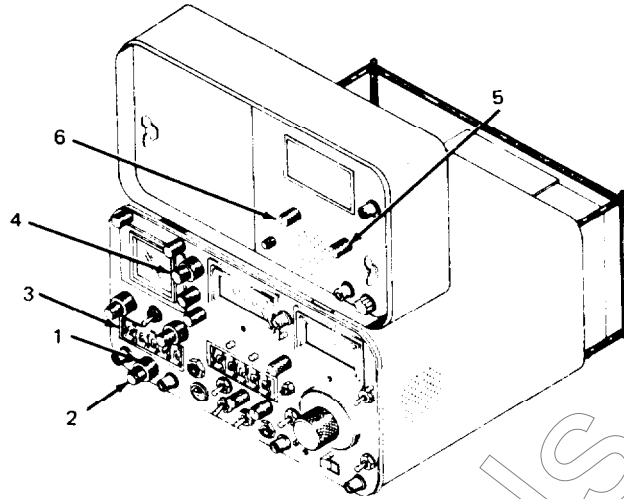


Figure 4-6. Audio generator controls, indicators, and connectors.

Table 4-14. Audio Generator Initial Adjustments and Control Settings

Figure 4-6 Reference No.	Control, indicator, or connector	Initial adjustment or setting
1	INT MOD/OFF control	Fully ccw, detent (OFF)
2	1 KHz INT MOD/OFF control	Fully ccw, detent (OFF)
3	MODULATION FREQ. Hz thumbwheels	0000.0 HZ
4	ANALY DISPR/OFF control	Fully ccw detent (OFF)
5	FUNCTION switch (MM-100)	HI-Z
6	RANGE switch (MM-100)	300

http://www.pdfbooks.com

Table 4-15. Audio Generation with MM-100 Operating Instructions

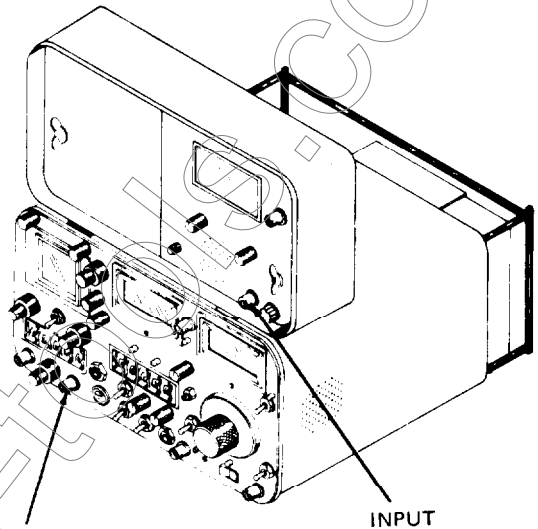
Step	Procedure	Illustration
1	<p>Connect one end of coaxial cable to INT MOD OUT connector and opposite end of cable to the INPUT jack of MM-100.</p>	
2	<p>Determine the input impedance of the unit to be tested and determine the level of the audio signal to be inserted into the UUT.</p>	

Table 4-15. Audio Generation with MM-100 Operating Instruction--Continued

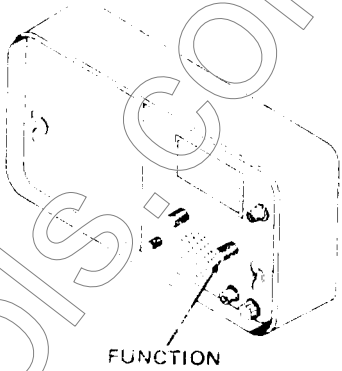
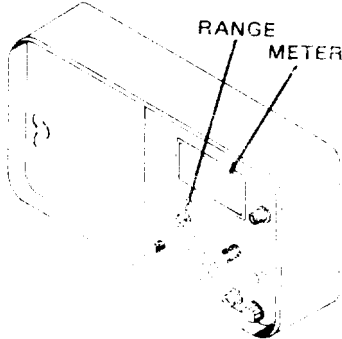
Step	Procedure	Illustration
3	Set the FUNCTION switch to the setting which corresponds with the impedance Of the UUT.	 <p>The illustration shows a perspective view of the MM-100 control panel. A label 'FUNCTION' with a pointer indicates a switch located on the right side of the panel, below the 'RANGE' switch.</p>
4	Set the RANGE switch to audio signal level to be injected into the UUT.	 <p>The illustration shows a perspective view of the MM-100 control panel. Two labels, 'RANGE' and 'METER', with pointers indicate a switch and a meter located on the right side of the panel.</p>

Table 4-15. Audio Generation with MM-100 Operating Instructions — Continued

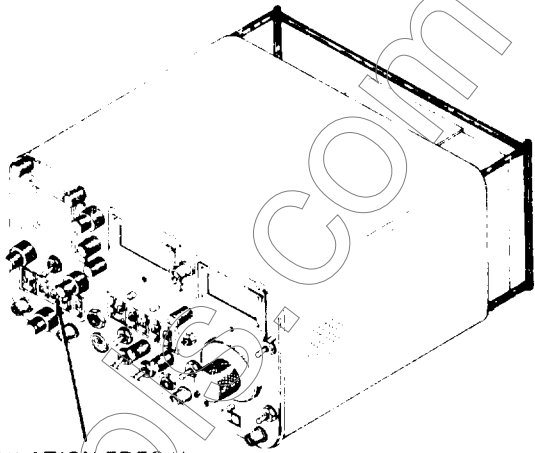
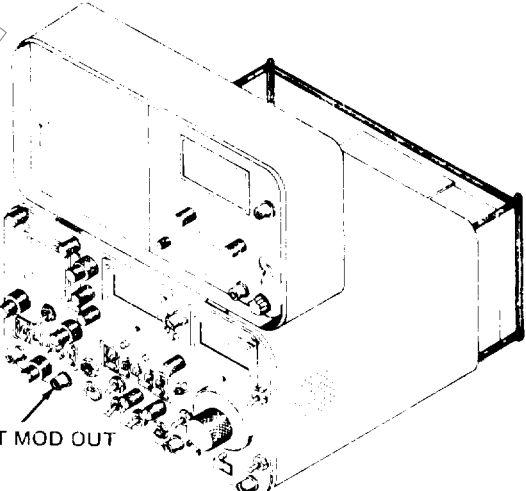
Step	Procedure	Illustration
5	Set MODULATION FREQUENCY Hz thumbwheels to the desired audio frequency.	 <p data-bbox="813 768 1068 789">MODULATION FREQ Hz</p>
6	Apply power to AN/GRM-114 as instructed in paragraph 4-3 and also apply power to UUT. While observing the MM-100 meter, adjust INT MOD/OFF control to the desired signal level (ac volts rms)	 <p data-bbox="824 1423 976 1444">INT MOD OUT</p>

Table 4-15. Audio Generation with MM-100 Operating Instructions – Continued

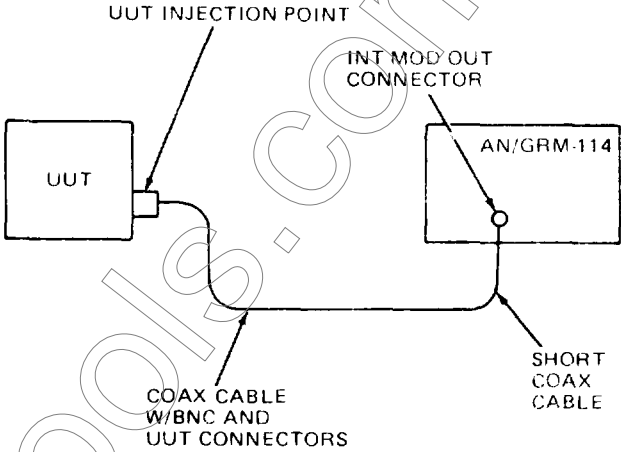
Step	Procedure	Illustration
7	Disconnect the end of the cable from the INPUT jack of the MM-100 and connect the cable to the input of the UUT.	

Table 4-16. Audio Generation with Oscilloscope Operating Instructions

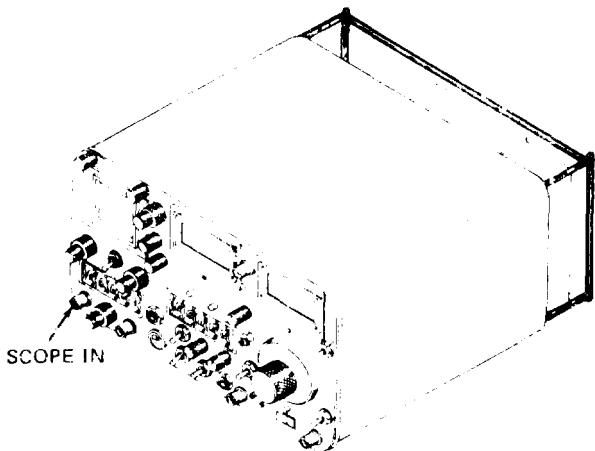
step	Procedure	Illustration
1	<p style="text-align: center;"><b>CAUTION</b></p> <p>Do not exceed 200 V (peak-to-peak) to SCOPE IN connector.</p> <p>Connect BNC tee connector to SCOPE IN connector.</p>	

Table 4-16. Audio Generation with Oscilloscope Operating Instructions – Continued

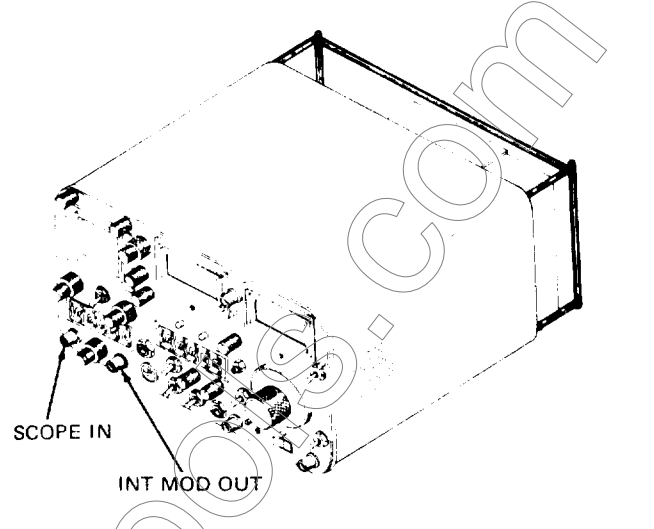
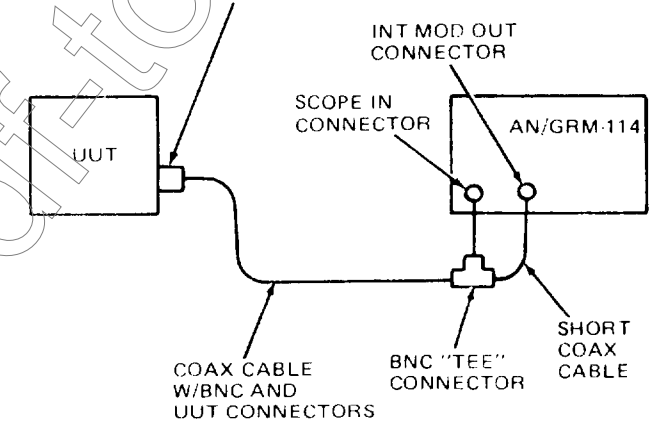
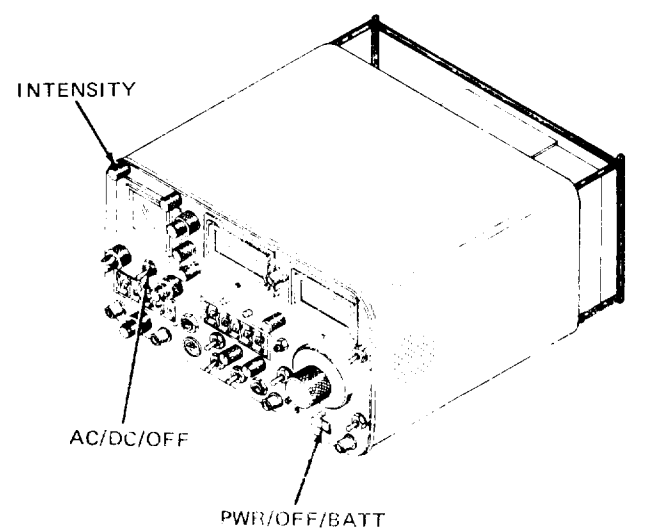
Step	Procedure	Illustration
2	<p>Connect one end of short coax cable to INT MOD OUT connector and opposite end to BNC tee connector previously attached to SCOPE IN connector.</p>	
3	<p>Apply power to UUT.</p>	
4	<p>Apply power to AN/GRM-114 as instructed in paragraph 4-3.</p>	
	<p style="text-align: center;"><b>CAUTION</b></p> <p>When applying power to oscilloscope or spectrum analyzer from PWR/OFF/BATT switch or AC/DC/OFF switch, make sure INTENSITY control is in moderate (left) position.</p>	

Table 4-16. Audio Generation with Oscilloscope Operating Instructions – Continued

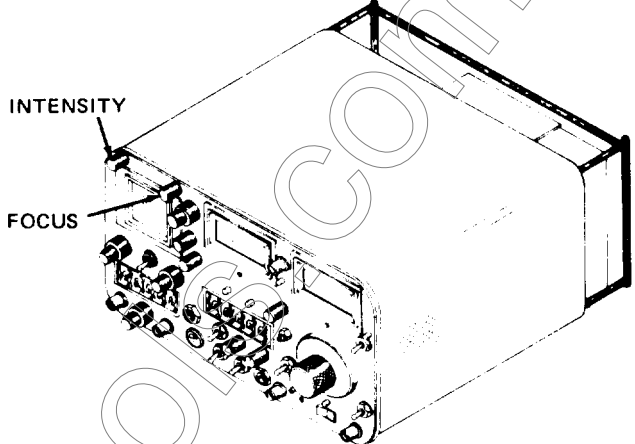
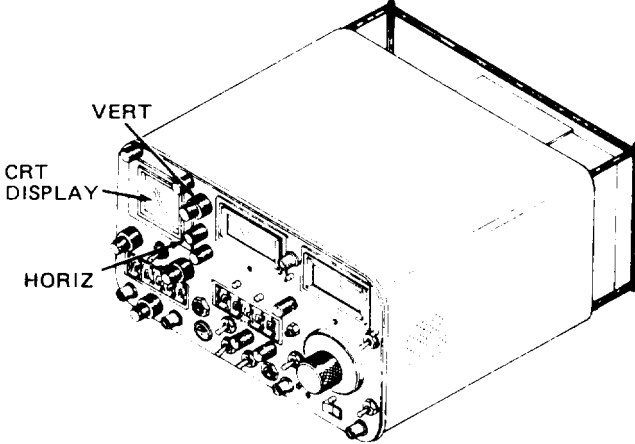
Step	Procedure	Illustration
5	<p>Adjust INTENSITY control cw and FOCUS control appropriately for a sharp visible trace display.</p> <p style="text-align: center;">NOTE</p> <p>Warmup time of crt is approximately 30 seconds from a "cold" startup; trace display will not become visible until crt achieves warmup.</p>	 <p>The illustration shows a perspective view of the oscilloscope's control panel. Two specific controls are highlighted with arrows and labels: 'INTENSITY' and 'FOCUS'. The panel is densely packed with various knobs, switches, and connectors.</p>
6	<p>Adjust VERT and HORIZ controls so that the trace is centered and aligned along major horizontal axis.</p>	 <p>The illustration shows a perspective view of the oscilloscope's control panel. Three controls are highlighted with arrows and labels: 'VERT', 'CRT DISPLAY', and 'HORIZ'. The panel is densely packed with various knobs, switches, and connectors.</p>



Table 4-16. Audio Generation with Oscilloscope Operating Instructions – Continued

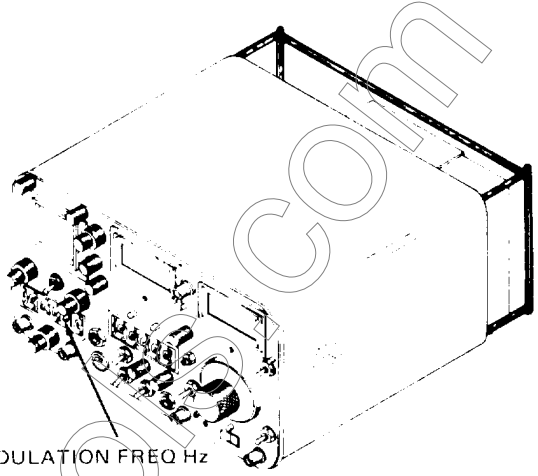
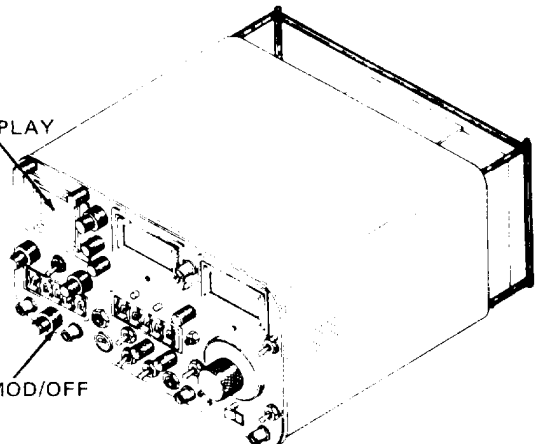
Step	Procedure	Illustration
7	Set MODULATION FREQ Hz thumb-wheels to desired audio frequency.	 <p>MODULATION FREQ Hz</p>
8	<p>For calibration, the level of the injected audio tone must be expressed in volts peak-to-peak. Volts rms or volts peak must be converted to volts peak-to-peak, using following formulas:</p> <p>volts peak-to-peak = 2.828 x volts rms</p> <p>volts peak-to-peak = 2 x volts peak</p>	
9	Rotate INT MOD Control to adjust waveform to desired amplitude in volts peak.	 <p>CRT DISPLAY</p> <p>INT MOD/OFF</p>

Table 4-16. Audio Generation with Oscilloscope Operating Instructions--Continued

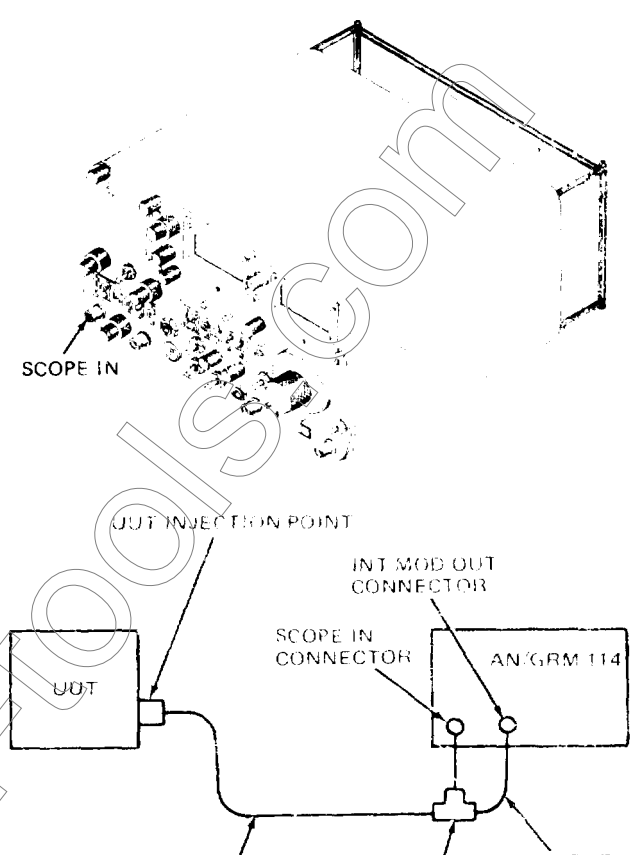
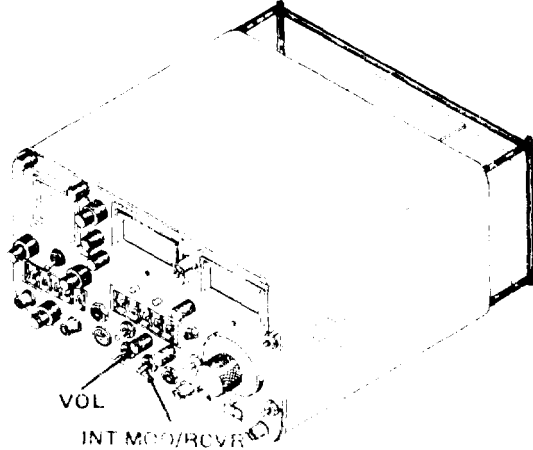
Step	Procedure	Illustration
10	<p style="text-align: center;"><b>CAUTION</b></p> <p>Do not exceed 200 V (peak-to-peak) to SCOPE IN connector.</p> <p>Connect BNC connector of remaining coax cable to tee connector attached to SCOPE IN connector. Connect opposite end of coax cable to injection point on UUT. Desired audio tone is now being injected into UUT.</p>	
11	<p>To monitor the injected tones, place INT MOD/RCVR switch to INT MOD and adjust VOL control for a comfortable listening level.</p>	

Table 4-16. Audio Generation with Oscilloscope Operating Instructions – Continued

Step	Procedure	Illustration
12	Emergency operating procedures. For emergency operating procedures (battery weakening) refer to table 4-2.	
13	Stopping procedures. Disconnect power from AN/GRM-114 as instructed in table 4-2 before disconnecting power from UUT.	

4-9. Power Monitor Function. Table 4-17 lists operating instructions for measuring transmitter carrier power. Such measurements utilize the power monitor.

4-10. Master Oscillator Calibration. Follow procedures in table 4-18 to calibrate master oscillator using a received time standard signal.

Table 4-17. Power Monitor Operating Instructions for Measuring Transmitter Carrier Power

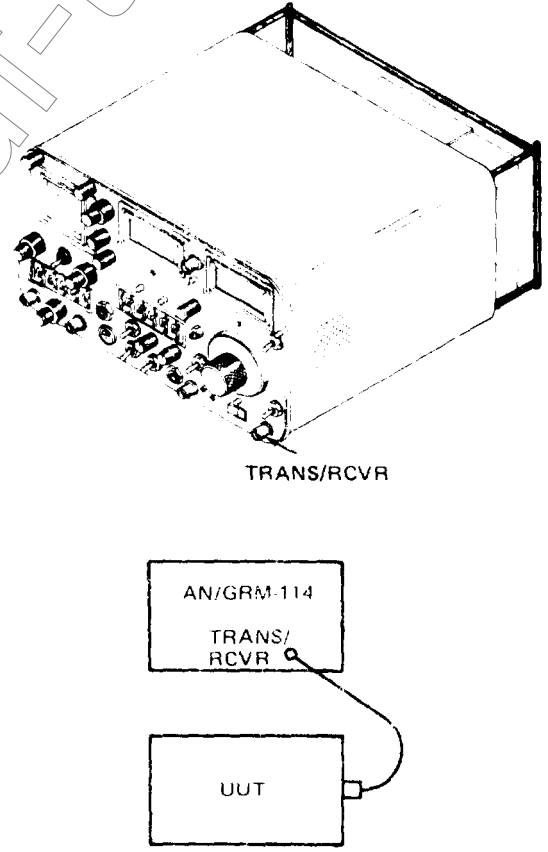
Step	Procedure	Illustration
	<p style="text-align: center;"><b>NOTE</b></p> <p>To apply power to the AN/GRM-114, refer to the instructions in paragraph 4-3.</p>	
1	Set controls for receive operation (AM or FM) as listed in table 4-9.	
2	Apply power to UUT.	
3	Connect coax cable between UUT RF output and AN/GRM-114 TRANS/RCVR connector.	 <p>The illustration shows a perspective view of the AN/GRM-114 unit with a label 'TRANS/RCVR' pointing to its front panel. Below this, a schematic diagram shows a box labeled 'AN/GRM-114' with a port labeled 'TRANS/RCVR' connected by a cable to a box labeled 'UUT'.</p>

Table 4-17. Power Monitor Operating Instructions for Measuring Transmitter Carrier Power — Continued

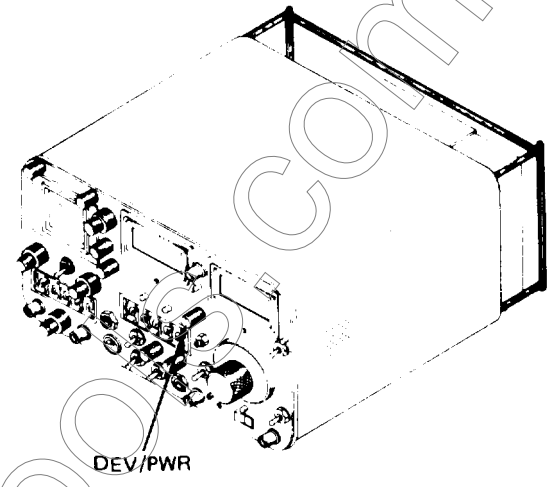
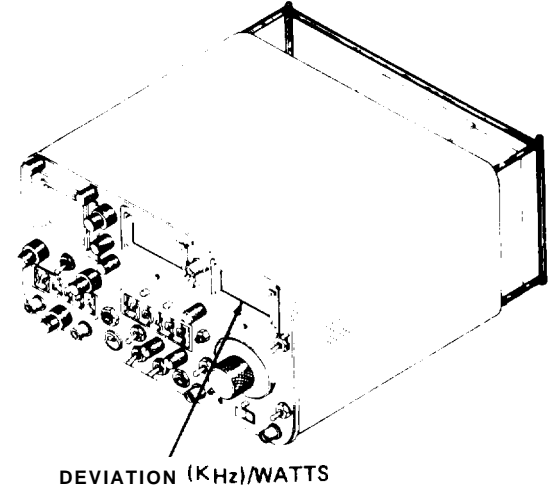
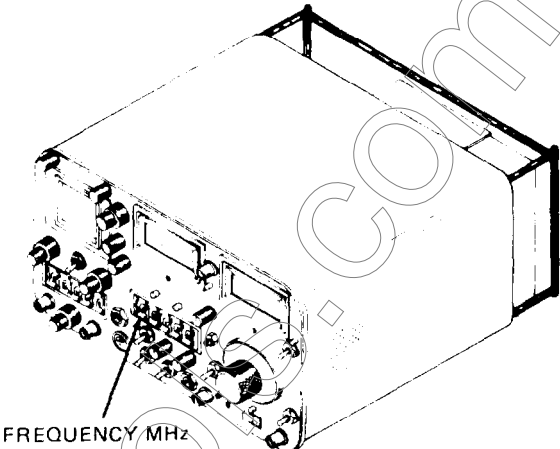
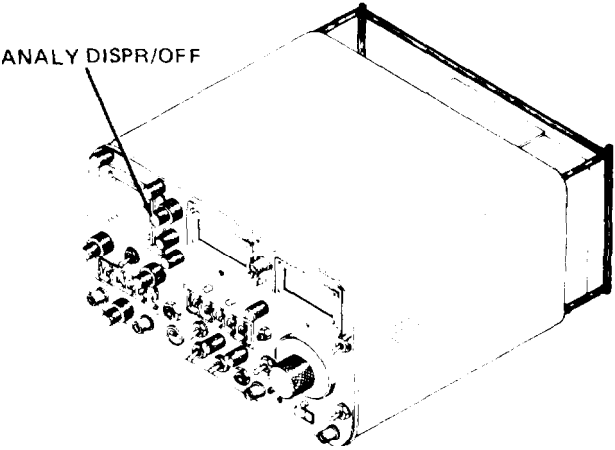
Step	Procedure	Illustration
4	<p>Rotate DEV/PWR control to WATTS x 10.</p> <p style="text-align: center;">NOTE</p> <p>Due to various construction of buildings, a national standard (e.g. WWV) signal may not be obtained without a rooftop antenna or relocation of AN/GRM-114 to an outdoor location.</p>	 <p style="text-align: center;">DEV/PWR</p>
5	<p>Key up UUT. Read UUT power output on red scale of DEVIATION (KHz) /WATTS meter.</p> <p style="text-align: center;">NOTE</p> <p>If DEVIATION (KHz) /WATTS meter needle deflection is less than 10 watts when UUT is keyed, rotate DEV/PWR control to WATTS x 1.</p>	 <p style="text-align: center;">DEVIATION (KHz)/WATTS</p>

Table 4-17, Power Monitoring Instructions for Measuring Transmitter Carrier Power – Continued

Step	Procedure	Illustration
6	Set FREQUENCY MHz thumbwheels to frequency of transmitter.	 <p>FREQUENCY MHz</p>
7	Set ANALY DISPR control w just short of detent.	 <p>ANALY DISPR/OFF</p>

**NOTE**

UUT power output can also be viewed on spectrum analyzer dB scale, using following approximate equivalences:

- 30 dB marking on spectrum analyzer = 100 watts,
- 40 dB marking on spectrum analyzer = 10 watts,
- 50 dB marking on spectrum analyzer = 1 watt, and
- 60 dB marking on spectrum analyzer = 0.1 watt.

Table 4-17. Power Monitor Operating Instructions for Measuring Transmitter Carrier Power – Continued

Step	Procedure	Illustration
8	Emergency operating procedures. For emergency operating procedures (battery weakening), refer to table 4-2.	
9	Stopping procedures. Refer to the stopping procedures in table 4-2.	

Table 4-18. Master Oscillator Calibration using Received Time Standard Signal

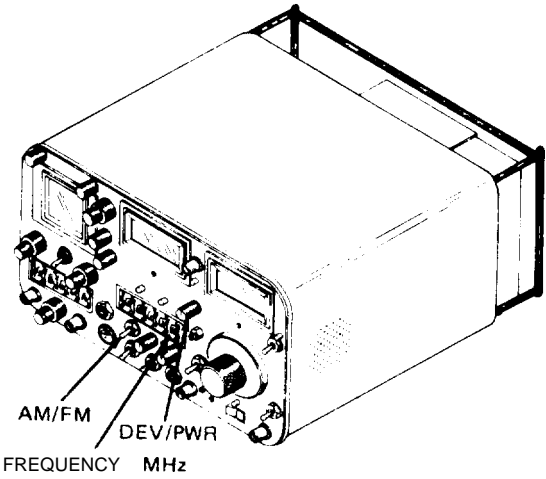
step	Procedure	Illustration
1	<p>Perform the steps necessary to receive AM signals as listed under paragraph 4-6.</p> <p style="text-align: center;">NOTE</p> <p>Set AM/FM switch to AM.</p> <p>Set FREQUENCY MHz thumbwheels to 10.0000 MHz.</p> <p>Set DEV/PWR control to SIG.</p>	 <p>The illustration shows a perspective view of a rectangular radio receiver. On the front panel, there are several controls. A label 'AM/FM' points to a switch on the left. A label 'DEV/PWR' points to a control knob in the center. A label 'FREQUENCY MHz' points to a set of thumbwheels on the right side of the front panel.</p>
2	Set AN/GRM-114 controls for oscilloscope operation as listed in table 4-7.	

Table 4-18. Master Oscillator Calibration using Received Time Standard Signal – Continued

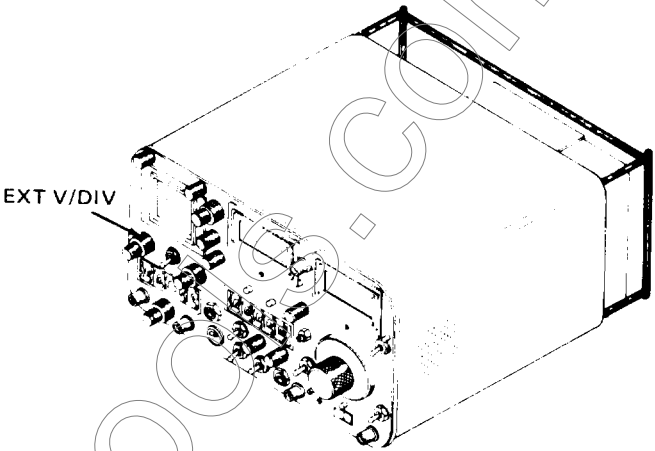
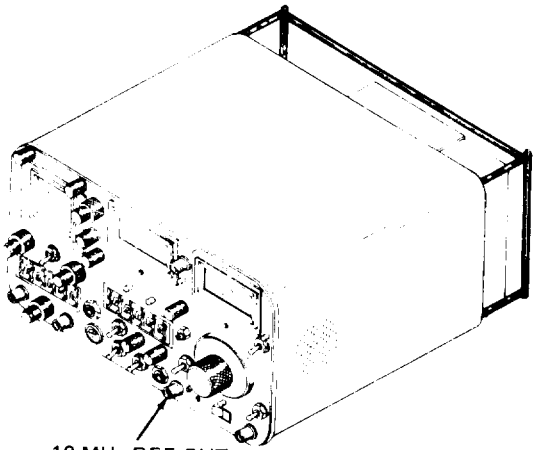
Step	Procedure	Illustration
3	Rotate EXT V/DIV control to 15 KHz.	 <p>The illustration shows a perspective view of the device's front panel. A label 'EXT V/DIV' with a pointer indicates the position of the control knob on the left side of the panel.</p>
4	Insert a short length of wire into center conductor of 10 MHz REF OUT connector.	 <p>The illustration shows a perspective view of the device's front panel. A label '10 MHz REF OUT' with a pointer indicates the location of the connector on the left side of the panel.</p>

Table 4-18. Master Oscillator Calibration using Received Time StanSignal — Continued

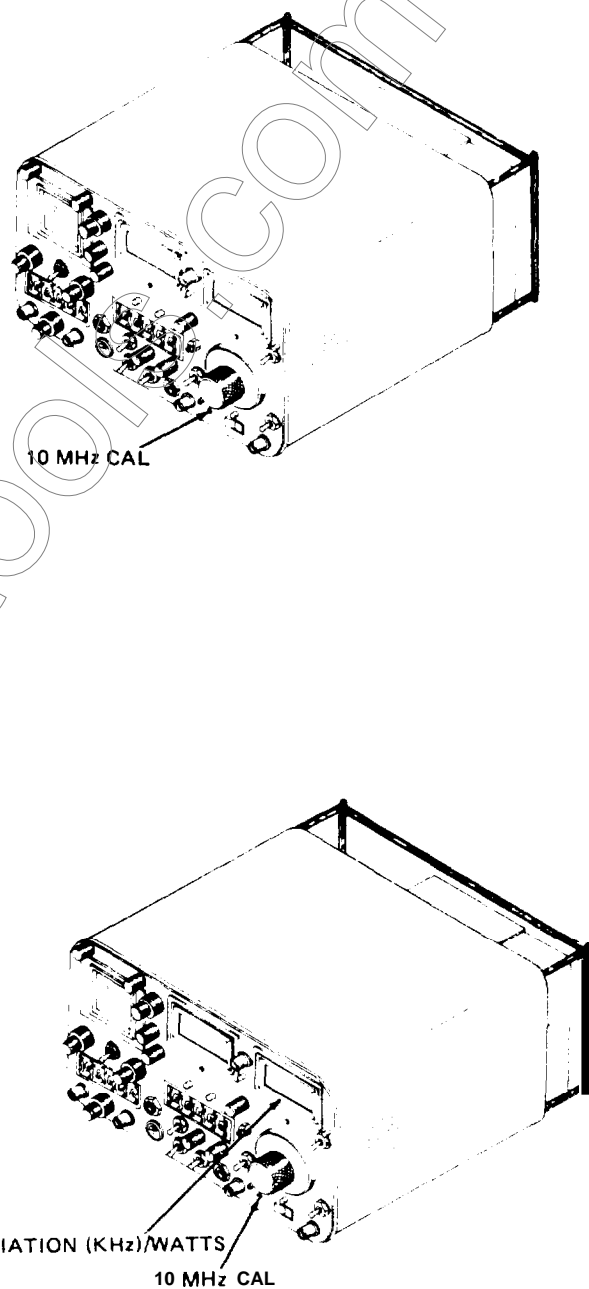
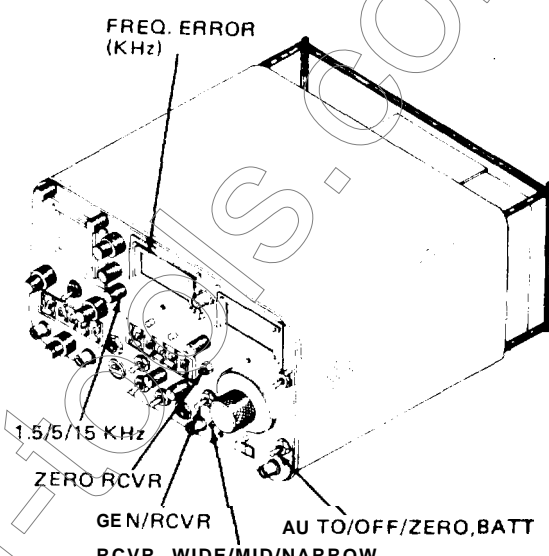
Step	Procedure	Illustration
5	Adjust position of wire to obtain a suitable beat note from AN/GRM-14 speaker.	
6	<p>Using small screwdriver, adjust the 10 MHz CAL adjustment until the beat note achieves as low a frequency as possible:</p> <p>(a) Initially, it is helpful to observe oscillation of the waveform on the oscilloscope while rotating 10 MHz CAL adjustment; adjust screw until oscillation diminishes to a point of being as close as possible to stationary.</p> <p>(b) While observing DEVIATION (KHz)/WATTS meter, continue to adjust the 10 MHz CAL adjustment until meter needle oscillation is as slow as possible. During this step, recheck oscilloscope to be sure the waveform is stable. Master oscillator is now calibrated in accordance with the time standard signal.</p>	 <p>The top illustration shows the internal components of the device, with a label '10 MHz CAL' pointing to a specific adjustment screw. The bottom illustration shows the same internal components, with labels 'DEVIATION (KHz)/WATTS' and '10 MHz CAL' pointing to the meter and the adjustment screw, respectively.</p>



Table 4-18. Master Oscillator Calibration using Received Time Standard Signal --- Continued

step	Procedure	
6 (Cont)	<p>NOTE</p> <p>Careful calibration can result in a beat frequency less than 0.1 Hz.</p>	 <p>The diagram shows a control panel with several components labeled: 'FREQ. ERROR (KHz)' at the top, a '1.5/5/15 KHz' control knob, a 'ZERO RCVR' knob, a 'GEN/RCVR' switch, and an 'AU TO/OFF/ZERO,BATT RCVR WIDE/MID/NARROW' switch. A large watermark 'http://www.pdf-tips.com' is overlaid on the diagram.</p>
7	<p>When calibrating the master oscillator for accurate frequency reference/measurement, the FREQ. ERROR meter should also be zeroed for reliable frequency measurements. Procedure is as follows:</p> <p>(a) Place GEN/RCVR switch to GEN.</p> <p>NOTE</p> <p>RCVR WIDE/MID/NARROW switch must be in NARROW.</p> <p>(b) Make sure AUTO/OFF/ZERO, BATT switch is in AUTO.</p> <p>(c) Rotate 1.5/5/15 KHz control to 1.5 KHz.</p> <p>(d) Adjust ZERO RCVR adjustment cw or ccw to center FREQ. ERROR meter needle at zero.</p>	
8	<p>Emergency operating procedures. Refer to the emergency operating procedures in step 9 of table 4-10, and in table 4-2.</p>	
9	<p>Stopping procedures. Refer to the stopping procedures in table 4-2.</p>	

4-11. The procedures in table 4-19 are for calibrating the master oscillator through an external source when a 10 MHz “off-the-air” reference signal is not available.

4-12. Frequency Error Measurement. Table 4-20 lists the initial adjustments and control settings (figure 4-7) necessary to measure frequency error. Table 4-21 lists the operating instructions.

Table 4-19. Master Oscillator Calibration using an External Frequency Standard

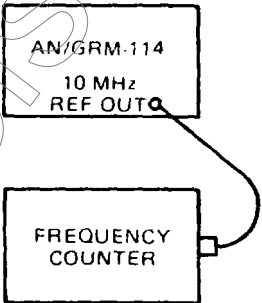
Step	Procedure	Illustration
1	Connect one end of coax cable to 10 MHz REF OUT connector.	
2	Connect opposite end of coax cable to input of frequency counter.	
3	Apply power to frequency counter.	
4	Apply power to AN/GRM-114 as instructed in paragraph 4-3.	
5	For most precise adjustment, wait approximately 5 minutes before proceeding with Step 6.	

Table 4-19. Master Oscillator Calibration using an External Frequency Standard — Continued

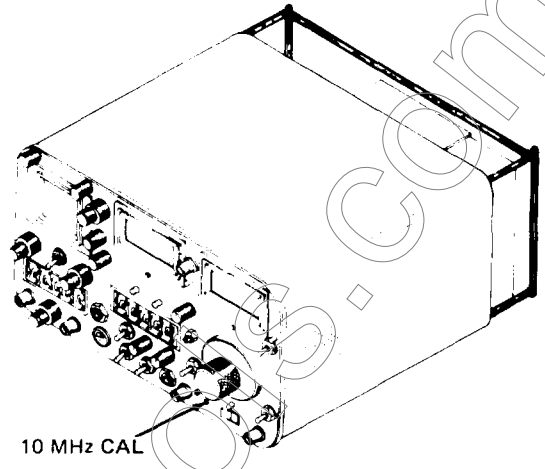
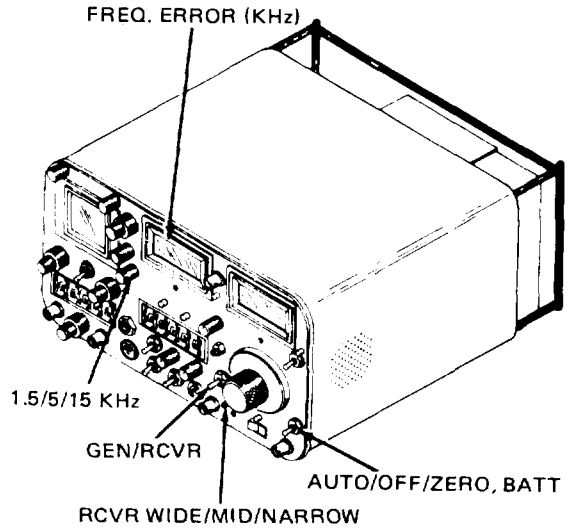
Step	Procedure	Illustration
6	<p>Adjust 10 MHz CAL adjustment until frequency counter reads 10.000000 MHz. Master oscillator is now calibrated to frequency counter.</p>	 <p>10 MHz CAL</p>
7	<p>When calibrating the master oscillator for accurate frequency reference/measurement, the <b>FREQ. ERROR</b> meter must be zeroed for reliable frequency measurements. Procedure is as follows:</p> <p>(a) Place <b>GEN/RCVR</b> switch to <b>GEN</b>.</p> <p><b>NOTE</b></p> <p><b>RCVR WIDE/MID/NARROW</b> switch must be in <b>NARROW</b>.</p> <p>(b) Make sure <b>AUTO/OFF/ZERO, BATT</b> switch is in <b>AUTO</b>.</p> <p>(c) Rotate <b>1.5/5/15 KHz</b> control to <b>1.5 KHz</b>.</p> <p>(d) Adjust <b>ZERO RCVR</b> adjustment cw or ccw to center <b>FREQ. ERROR</b> meter needle at zero.</p>	 <p>FREQ. ERROR (KHz)</p> <p>1.5/5/15 KHz</p> <p>GEN/RCVR</p> <p>AUTO/OFF/ZERO, BATT</p> <p>RCVR WIDE/MID/NARROW</p>

Table 4-19. Master Oscillator Calibration using an External Frequency Standard – Continued

Step	Procedure	Illustration
8	Emergency operating procedures. For emergency operating procedures (battery weakening) refer to table 4-2.	
9	Stopping procedures. Disconnect power from AN/GRM-114 as instructed in table 4-2 before disconnecting power from frequency counter.	

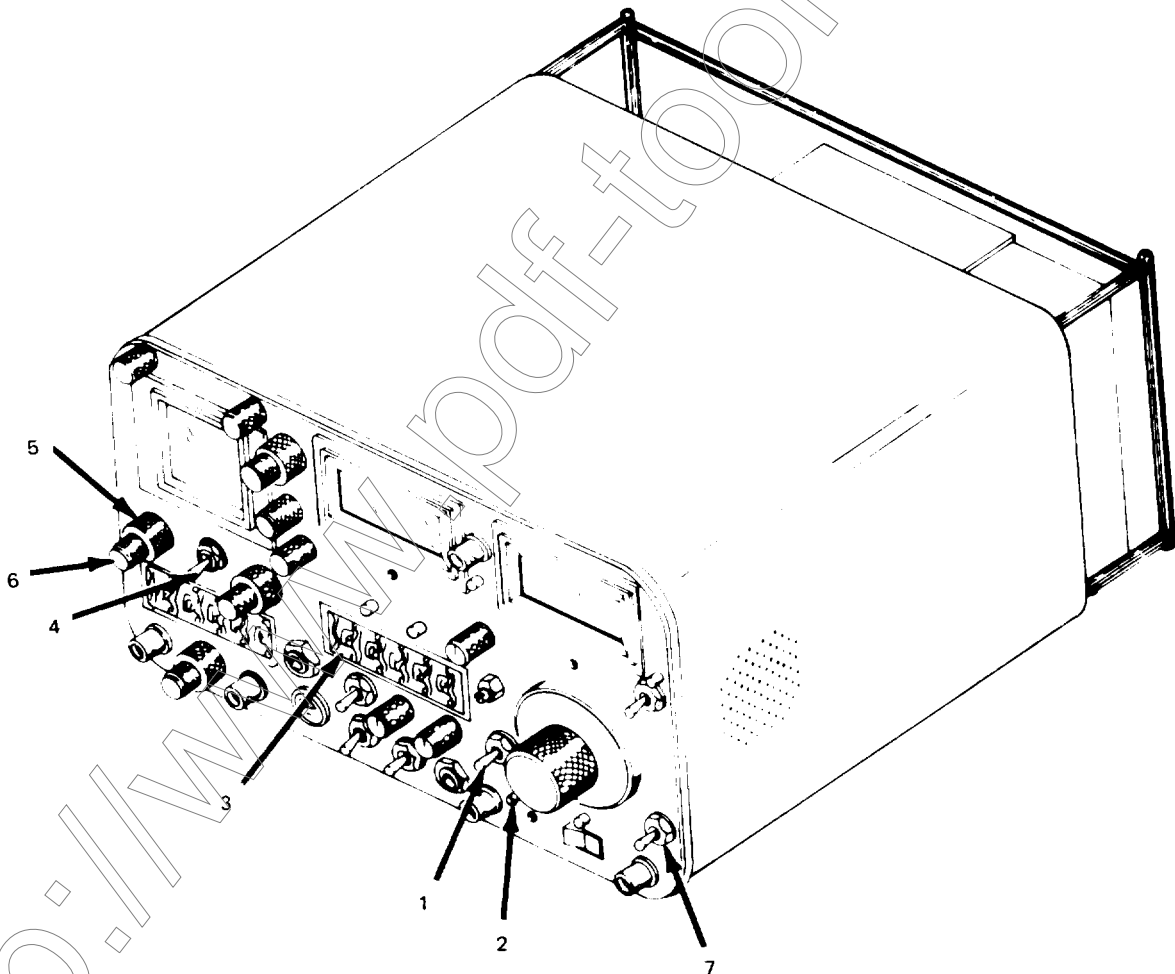


Figure 4-7. Frequency error measurement controls, indicators and connectors

Table 4-20. Initial Adjustments and Control Settings

Figure 4-7 Reference No.	Control, indicator, or connector	Initial adjustment or setting
1	GEN/RCVR switch	RCVR
2	RCVR WIDE/MID/NARROW	NARROW
3	FREQUENCY MHz thumbwheel switches	0000000
4	AC/DC/OFF switch	DC
5	EXT V/DIV control	15 KHz
6	EXT V/DIV vernier control	CAL
7	AUTO/OFF/ZERO, BATT switch	AUTO
8	AM/FM switch	FM

Table 4-21. Frequency Error Measurement Operating Instructions

Step	Procedure	Illustration
1	<p><b>CAUTION</b></p> <p>When applying power to the oscilloscope or spectrum analyzer from the PWR/OFF/BATT switch or from the AC/DC/OFF switch, make sure INTENSITY control is in moderate (left) position.</p> <p>Center the oscilloscope trace using the HORIZ and VERT controls.</p>	<p>The diagram shows the front panel of the oscilloscope with several controls labeled. From left to right, the labels are: INTENSITY (pointing to a knob), FOCUS (pointing to a knob), VERT (pointing to a vertical slider), HORIZ (pointing to a horizontal slider), CRT DISPLAY (pointing to the screen area), AC/DC/OFF (pointing to a switch), and PWR/OFF/BATT (pointing to a switch).</p>

Table 4-21. Frequency Error Measurement Operating Instructions – Continued

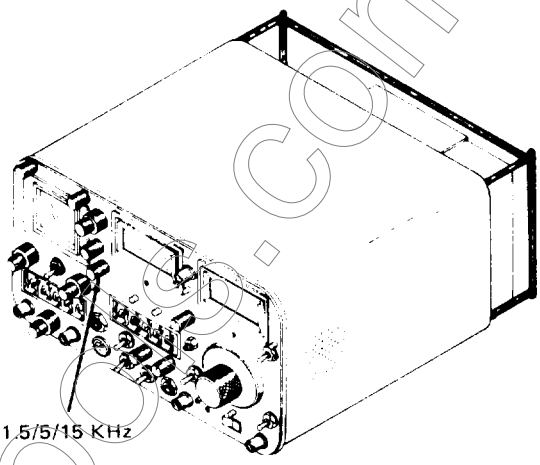
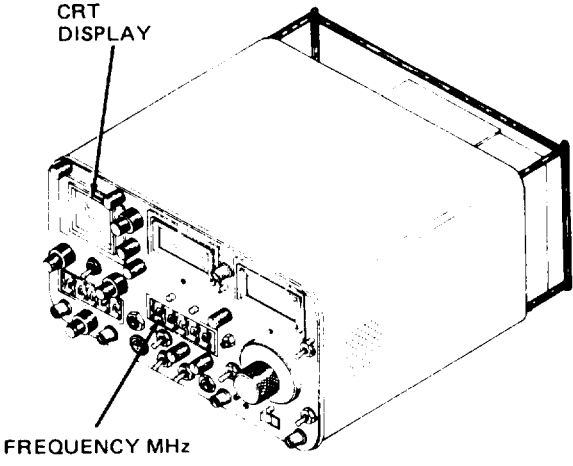
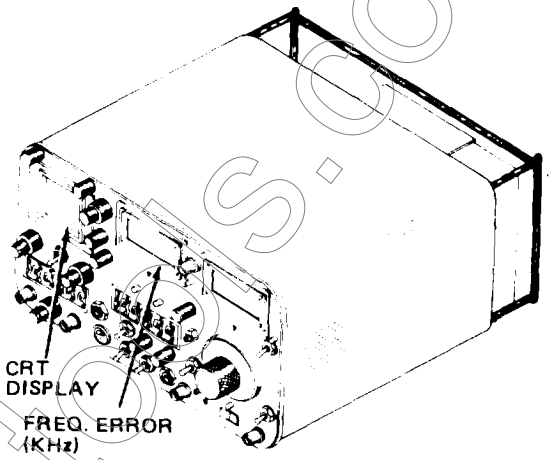
Step	Procedure	Illustration
2	Set the 1.5/5/15 KHz control to the 15 KHz.	 <p>1.5/5/15 KHz</p>
3	Set FREQUENCY MHz thumbwheel switches to 0000100.	 <p>CRT DISPLAY</p> <p>FREQUENCY MHz</p>

Table 4-21. Frequency Error Measurement Operating Instructions – Continued

Step	Procedure	Illustration
4	Verify that both the oscilloscope and the FREQ. ERROR (KHz) meter read -10 KHz.	 <p>The illustration shows the rear panel of a piece of electronic equipment. Two specific components are highlighted with arrows and labels: 'CRT DISPLAY' and 'FREQ. ERROR (KHz)'. The panel also features various other connectors and controls, including what appears to be a 'C-10' label and several circular ports.</p>
5	Other oscilloscope and FREQ. ERROR (KHz) meter ranges may be checked in the same manner.	
6	Emergency operating procedures. For emergency operating procedures (battery weakening) refer to table 4-2.	
7	Stopping procedures. Refer to the stopping procedures in table 4-2.	

4-13. Audio Frequency Monitor Function. For a demonstration of the audio frequency monitor function, refer to the audio generator operating instructions in paragraph 4-8.

4-14. Multimeter Operating Instructions. Table 4-22 lists operating instructions for the multimeter, using signals generated by the AN/GRM-114.

Table 4-22. Multimeter Operating Instructions

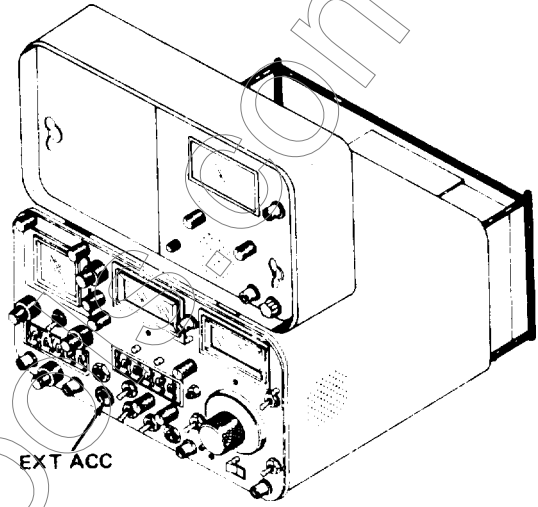
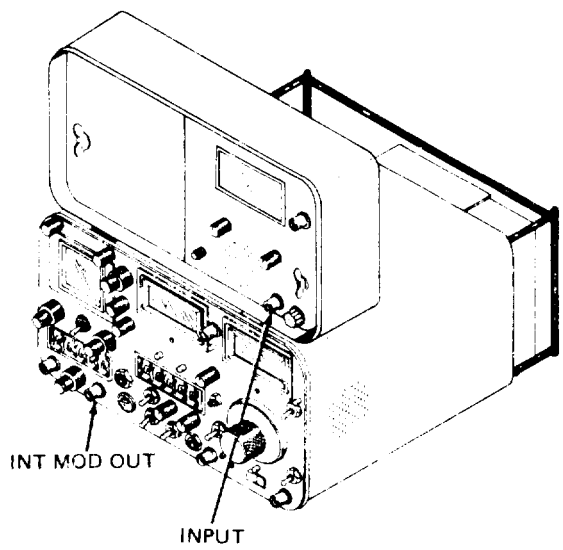
Step	Procedure	Illustration
1	<p style="text-align: center;"><b>CAUTION</b></p> <p>Do not exceed 300 V into the multimeter INPUT connector.</p> <p>Connect the multipronged cable, which is built into the multimeter, to the EXT ACC connector.</p>	 <p>This illustration shows a perspective view of a multimeter with its top cover open. A line points to a specific connector on the front panel labeled "EXT ACC".</p>
2	<p>Connect the 2-ended BNC cable between the INT MOD OUT connector and the multimeter INPUT connector.</p>	 <p>This illustration shows a perspective view of the same multimeter with its top cover open. Two lines point to connectors on the front panel: one labeled "INT MOD OUT" and another labeled "INPUT".</p>



Table 4-22. Multimeter Operating Instructions — Continued

Step	Procedure	Illustration
3	To apply power to the AN/GRM-114, refer to the instructions in paragraph 4-3.	<p>This illustration shows a perspective view of the multimeter's control panel. Three labels with leader lines point to specific controls: 'RANGE' points to a rotary switch on the left, 'METER' points to the central meter display, and 'FUNCTION' points to a rotary switch on the right. A fourth label, 'INT MOD/OFF', points to a control on the bottom left of the panel.</p>
4	To generate a signal, refer to the instructions in tables 4-3, 4-4, 4-5, and 4-6.	
5	To measure ac voltage of the generated signal, set FUNCTION control to HI-Z. Set RANGE control to the VOLTS position which gives best meter reading (top or second scale, depending on VOLTS position). Rotate INT MOD/OFF control to vary voltage.	
	NOTE	
	The multimeter measures "distortion of 1-kHz signals only.	
6	To measure distortion of the generated signal, set RANGE control to the DIST position -which gives best meter reading (top or second scale, depending on the DIST position).	<p>This illustration shows a perspective view of the multimeter's control panel, focusing on the meter area. Two labels with leader lines point to controls: 'RANGE' points to the rotary switch on the left, and 'METER' points to the central meter display.</p>

Table 4-22. Multimeter operating Instructions – Continued

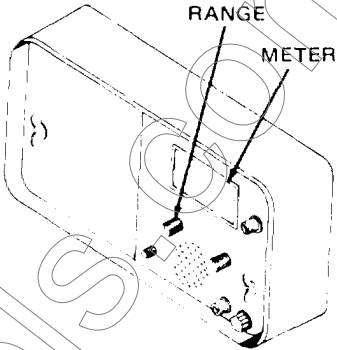
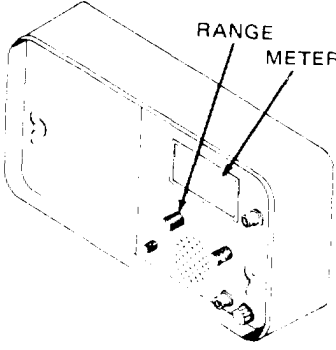
Step	Procedure	Illustration
7	<p>To measure SINAD value of applied signal, set RANGE control to SINAD. Read value on SINAD scale of meter.</p> <p style="text-align: center;"><b>NOTE</b></p> <p>For the following step, the AM/FM switch of the AN/GRM-114 must be in AM position.</p> <p>Adjust the FREQUENCY MHz thumbwheel switches to generate an AM signal.</p>	
8	<p>To read the AM% modulation of the applied signal, set RANGE control of multimeter to AM% position, read meter indication on top or second scale.</p>	

Table 4-22. Multimeter Operating Instructions – Continued

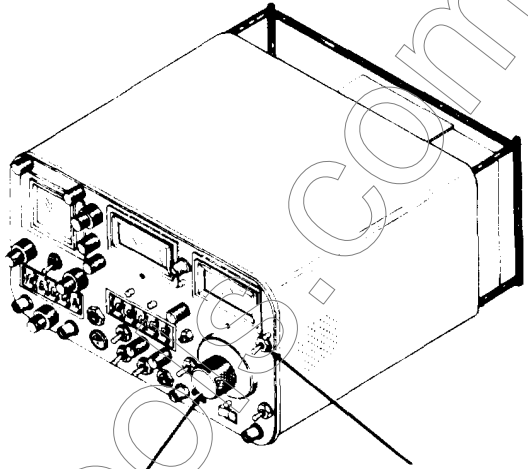
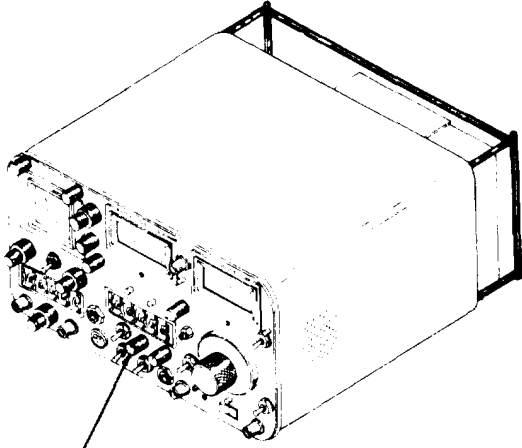
Step	Procedure	Illustration
9	Adjust INT MOD/OFF control for desired AM% modulation. Accuracy will be best with a 1-kHz signal.	 <p data-bbox="847 846 1125 874">RF LEVEL/BFO INJECTION</p> <p data-bbox="1158 832 1405 859">HI LVL/<math>\mu</math>V X 100/NORM</p>
10	Adjust the VOL control for a comfortable listening level.	 <p data-bbox="935 1634 981 1661">VOL</p>

Table 4-22. Multimeter operating Instructions – Continued

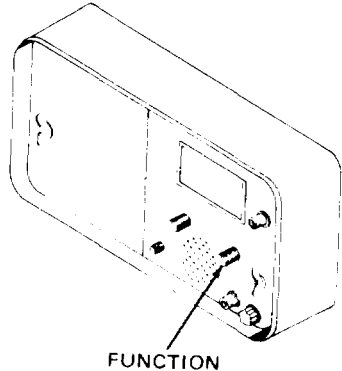
Step	Procedure	Illustration
11	<p style="text-align: center;"><b>NOTE</b></p> <p>To measure dc voltage and resistance, a source external to the AN/GRM-114, or a battery external to the AN/GRM-114 is required.</p> <p>If using source external to the AN/GRM-114, connect one end of 2-ended BNC cable to INPUT connector of multimeter and one end to output of external source. Make sure power is applied to AN/GRM-114 and thus to multimeter before applying power to external sources. Then refer to instructions in tables 4-9 and 4-10.</p> <p style="text-align: center;"><b>CAUTION</b></p> <p>Do not exceed 600 V ac or 800 V dc on the multimeter probe.</p> <p>To measure dc voltage, set FUNCTION control to + or — DC depending on voltage to be measured.</p>	 <p style="text-align: center;">FUNCTION</p>

Table 4-22. Multimeter Operating Instructions — Continued

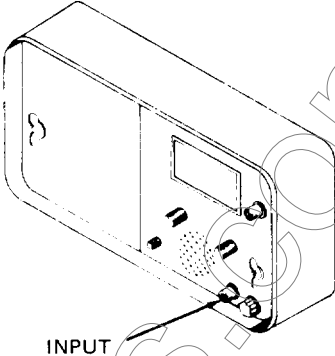
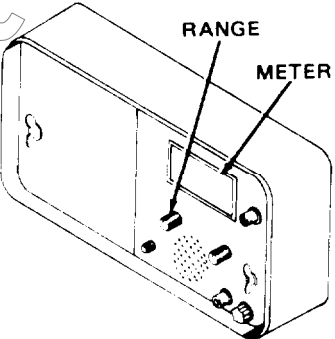
Step	Procedure	Illustration
12	Disconnect 2-ended BNC cable.	 <p data-bbox="964 638 1029 659">INPUT</p>
13	Connect multimeter probe to INPUT connector.	
14	Set RANGE control to the VOLTS position which gives the best meter reading (on either the top or second scale, depending on VOLTS position).	 <p data-bbox="1101 932 1182 953">RANGE</p> <p data-bbox="1175 974 1256 995">METER</p>
<p style="text-align: center;"><b>CAUTION</b></p> <p>When no longer measuring resistance, remove FUNCTION control from OHMS (only) position. Placing multimeter probes across large voltages when in OHMS (only) position will blow multimeter fuse.</p>		

Table 4-22. Multimeter Operating Instructions — Continued

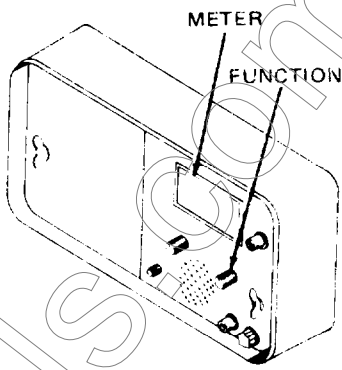
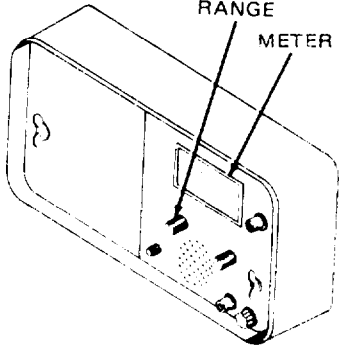
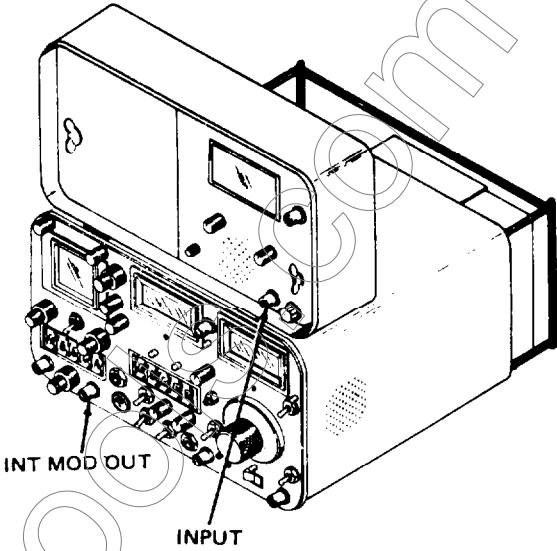
Step	Procedure	Illustration
15	To measure resistance, set FUNCTION control to OHMS (only).	
16	Connect multimeter probe across resistance to be measured.	
17	Set RANGE control to the OHMS position which gives the best meter reading (on OHMS scale).	

Table 4-22. Multimeter Operating Instructions — Continued

Step	Procedure	Illustration
18	Emergency operating procedures., Refer to the emergency operating procedures in step 9 of table 4-10 and in table 4-2.	
19	<p>Stopping procedures,</p> <p>(a) Refer to the stopping procedures in table 4-2.</p> <p>(b) Disconnect BNC cable from INPUT connector of multimeter and INT MOD OUT connector of AN/GRM-114, or output of external signal source.</p>	

<http://www.pdf-toc.com>

CHAPTER 5

MAINTENANCE INSTRUCTIONS

**WARNING**

Dangerous voltages exist within the AN/GRM-114 while the unit is operating. Personnel should be familiar with the requirements of TB-385-4 before attempting maintenance,

5-1. General.

This chapter contains maintenance, troubleshooting, and disassembly/reassembly instructions.

5-2. AN/GRM-114 Routine Maintenance Checks and Services.

a. Recommended cleaning supplies: Denatured alcohol, soft bristle brush, lint-free cloth and hand controlled dry air jet (30 psi maximum pressure).

**CAUTION**

Use air jet cautiously to avoid damaging fragile components.

b. Remove dust and dirt from AN/GRM-114 case, thumb wheel switches, meters, and rear panel.

5-3. Tools and Test Equipment. Table 5-1 lists tools and test equipment necessary to perform the AN/GRM-114 maintenance.

Table 5-1. Tools and Test Equipment

Tool or test equipment	Tool number
<b>NOTE</b>	
Test equipment with equivalent specifications can be substituted for the items listed below.	
Oscilloscope with X10 Probe	OS-262(P)/U
Frequency Counter	TD-1225A(V)1/U
Spectrum Analyzer, with Plug-in module	141T (28480) 8555A (28480)
Variable Attenuator, Texscan	Texscan RA-50 (23042)
Digital Multimeter	AN/USM-451
High voltage probe, Calif. Instrument	Calif. Instrument HV-30 (12897)
Distortion analyzer	AN/URM-184A 334A (28480)



Table 5-1. Tools and Test Equipment — Continued

Tool or test equipment	Tool number
VSWR Bridge, Wiltron	Wiltron (60-N50) (87807)
Function Generator	SG-1133
Signal Generator	AN/USM-308(V)1
Sweep Signal Generator	Wavetek (2002) (Z3338)
Tracking generator	SG-1125/U
Triple output power supply, 50V @ 2 Amp	LAMBDA (LPT-7202FM) (80103)
50 W termination	IFR 2650-0010-200 (51190)
Power supply, 10 to 30 V variable @ 10 Amp	LAMBDA LK351FM (80103)
Wattmeter, AN/URM-120	AN/URM-120
Modulation meter	ME-57/U
VHF transmitter	RT-524/VRC
R.F. Power meter with power detector head	42BD (04901) 41-41A (04901)
Comp assy, AGC monitor meter	IFR 7003-9801-500 (51190)
Comp assy, battery load box	IFR 1003-9801-600 (51190)
Resistor, 390-k W, ¼ W	IFR 4702-0394-003 (51190)
PCB assy extender, 79-80 MHz Loop	IFR 7010-9801-200 (51190)
PCB assy extender. reg & pwr supply	IFR 7010-9801-300 (51190)
PCB assy extender, 250 kHz I.F.	IFR 7010-9801-400 (51190)

Table 5-1. Tools and Test Equipment--Continued

Tool or test equipment	Tool number
Test lead BNC to SMB (2)	IFR 6050-0032-400 (51190)
Test lead BNC to SMA (2)	IFR 6050-0092-400 (51190)
Test lead BNC to BNC (2)	IFR 6050-0522-400 (511.90)
Connector, SMB tee	IFR 2200-0250-100 (51190)
Connector, BNC tee	IFR 2105-1410-900 (51190)
Adapter, SMB Jack to Jack	IFR 2123-0000-016 (51190)
Adapter, SMA Jack to Jack	IFR 2200-0110-100 (51190)
High frequency multiplier/ mixer sniffer	IFR 6500-9801-700 (51190)
Extender cable (9 pin)	IFR 6046-9801-800 (51190)
Resistor, 470 W, ¼W	IFR 4702-0471-003 (51190)
Coax cable with sniffer loop	IFR 6050-0534-800 (51190)
Test lead SMB to SMB (2)	IFR 6050-0042-220 (51190)
Resistor, 300 W, ¼W	IFR 4706-3011-001 (51190)
Resistor, 300 k W, 1%	
Resistor, 30 k W, 1%	
Resistor, 600 W, 5%	
Resistor, 150 W, 5%	
Resistor, 8 W, 5%	
Resistor, 3.3 W, 5%	
Tool kit, Electronic Equipment TK - 100 / G	

5-4. Glossary. Table 5-2 contains a glossary of frequently used abbreviations found within this manual.

5-5. AN/GRM-114 Performance Test.

a. General. Figure 5-2 and tables 5-3 and 5-4 provide performance testing information for the AN/GRM-114. These procedures set forth specific requirements that the unit must meet before it is returned to the using organization. The procedures may be used as minimum performance tests or used to confirm a fault within a unit suspected of failure. Isolation of a con-

firmed fault is provided in the troubleshooting section of paragraph 5-6.

b. Presentation. The performance test provided is given in the form of a flowchart. Follow the step-by-step directions given within this flow chart. Set switches on the AN/GRM-114 according to tables 5-3 and 5-4 only when these tables are referenced within the flowchart. Any dashed number located inside a connector circle refers to a figure number within the troubleshooting section of paragraph 5-6. Figure 5-1 is an example of the application of flowchart symbols. Refer to this figure when necessary.

Table 5-2. Glossary of Abbreviations (Sheet 1 of 2).

Abbr.	Definition
A	Ampere
ac	alternating current
adj	adjust
AM	amplitude modulation
ampl	amplifier
ant	antenna
assy	assembly
atten	attenuator
bd	board
batt	battery
BFO	beat-frequency oscillator
ckt	circuit
cw	clockwise
ccw	counterclockwise
CRT	Cathode-ray tube
dB	decibel
dBm	decibel, referred to 1 milliwatt
dc	direct current
DCR	duty cycle regulator
devn	deviation
div	division
ext	external
FM	frequency modulation
freq	frequency
gen	generate, generator
Het. amp	heterodyne amplifier
ht	height
horlz	horizontal
Hz	Hertz
inj	inject, injection
intl	internal
kHz:	kilohertz
L.O.	local oscillator
mA	milliamp
mS	millisecond
mV	millivolt

Table 5-2. Glossary of Abbreviations (Sheet 2 of 2).

Abbr.	Definition
maj	major
min	minor
MHz	megahertz
mod	modulation
NLT	not less than
NMT	not more than
norm	normal
OSC	oscillate, oscillator
P.C.B.	printed circuit board
P-P	peak to peak
rf	radio frequency
rms	root mean square
SA	spectrum analyzer
sig	signal
tcxo	temperature-compensated crystal oscillator
T.p.	test point
$\mu$ V	microvolt
V ac	volts, alternating current
V.C.O.	voltage controlled oscillator
V dc	volts, direct current
V/DIV	volts per division
v p-p	volts, peak to peak
V rms	volts, root mean square
vert	vertical
vol	volume
W	watt
xtal	crystal
<	less than
>	greater than

Table 5-3. AN/GRM-114 Performance Test - Initial Conditions.

Step	AN/GRM-114 setting
1.	INTENSITY control to 3 o'clock position
2.	EXT V/DIV switch to 15 KHz
3.	EXT V/DIV vernier to CAL
4.	AC/DC switch to DC
5.	SWEEP switch to 1 mS
6.	SWEEP vernier to CAL
7.	MODULATION FREQ Hz switches to 1000.0
8.	INT MOD control to OFF
9.	1 KHz INT MOD control to OFF
10.	VERT control to 12 o'clock position
11.	ANALY DISPR control ccw to OFF
12.	HORIZ control to 12 o'clock position
13.	1.5/1.5/15 KHz switch to 15
14.	AM/FM switch to AM
15.	BFO switch to OFF

Table 5-3. AN/GRM-114 Performance Test - Initial Conditions – Continued.

Step	AN/GRM-114 setting
1 6 .	FREQUENCY MHz switch to 1110000
1 7 .	VOL control to 9 o'clock position
1 8 .	INT MOD/RCVR switch to RCVR
1 9 .	SQUELCH control ccw to detent stop (not off)
2 0 .	DEV/PWR switch to SIG
2 1 .	GEN/RCVR switch to RCVR
2 2 .	RCVR WIDE/MID/NARROW switch to NARROW
2 3 .	RF LEVEL/BFO INJECTION dial to 10
2 4 .	HI LVL/NORM switch to NORM
2 5 .	AUTO/ZERO, BATT switch to AUTO
2 6 .	Plug line cord into an active AC outlet.

Table 5-4. AN/GRM-114 Performance Test - Initial Conditions.

Step	AN/GRM-114 setting
1.	INT MOD control to OFF
2.	1 KHz INT MOD control to OFF
3.	GEN/RCVR switch to GEN
4.	INT MOD/RCVR switch to RCVR
5.	HI LVL/NORM switch to $\mu$ V X 100
6.	FREQUENCY MHz switches to 0000500
7.	RF LEVEL/BFO INJECTION' dial to 10
8.	EXT V/DIV switch to .01
9.	1.5/5/15 KHz switch to 15

5-6 AN/GRM-114 Troubleshooting.

a. General. Figures 5-3 through 5-12, and tables 5-5 through 5-9 provide troubleshooting information for the AN/GRM-114. These procedures set forth specific methods to isolate a problem to a mechanical assembly or circuit board. The technician is then referred back to the performance test of figure 5-2. Use these procedures as a guide to problem isolation.

b. Presentation. The troubleshooting procedures provided are given in the form of flow-

charts. Follow the step-by-step directions given within these flowcharts. Set switches on the AN/GRM-114 according to tables 5-5,5-7, and 5-9 only when these tables are referenced within the flowcharts. Perform these troubleshooting procedures when referenced by their figure number from the performance test of figure 5-2, or when a problem is apparent in one of the assemblies covered. Figure 5-1 is an example of the application of flowchart symbols. When necessary refer to component location diagrams located at the end of the alignment procedures to find referenced connectors, jacks, and potentiometers.

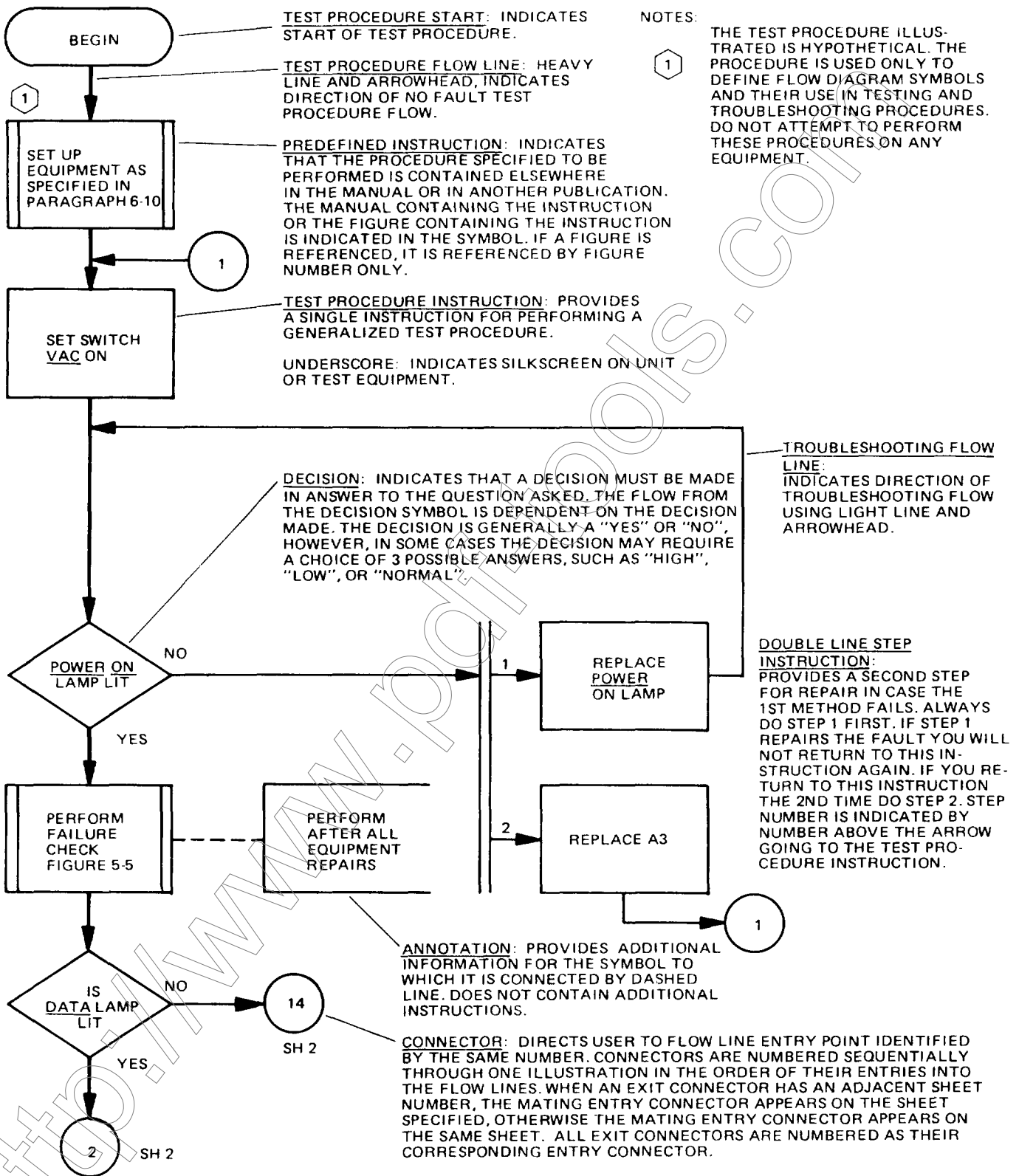


Figure 5-1. Flowchart symbol application.

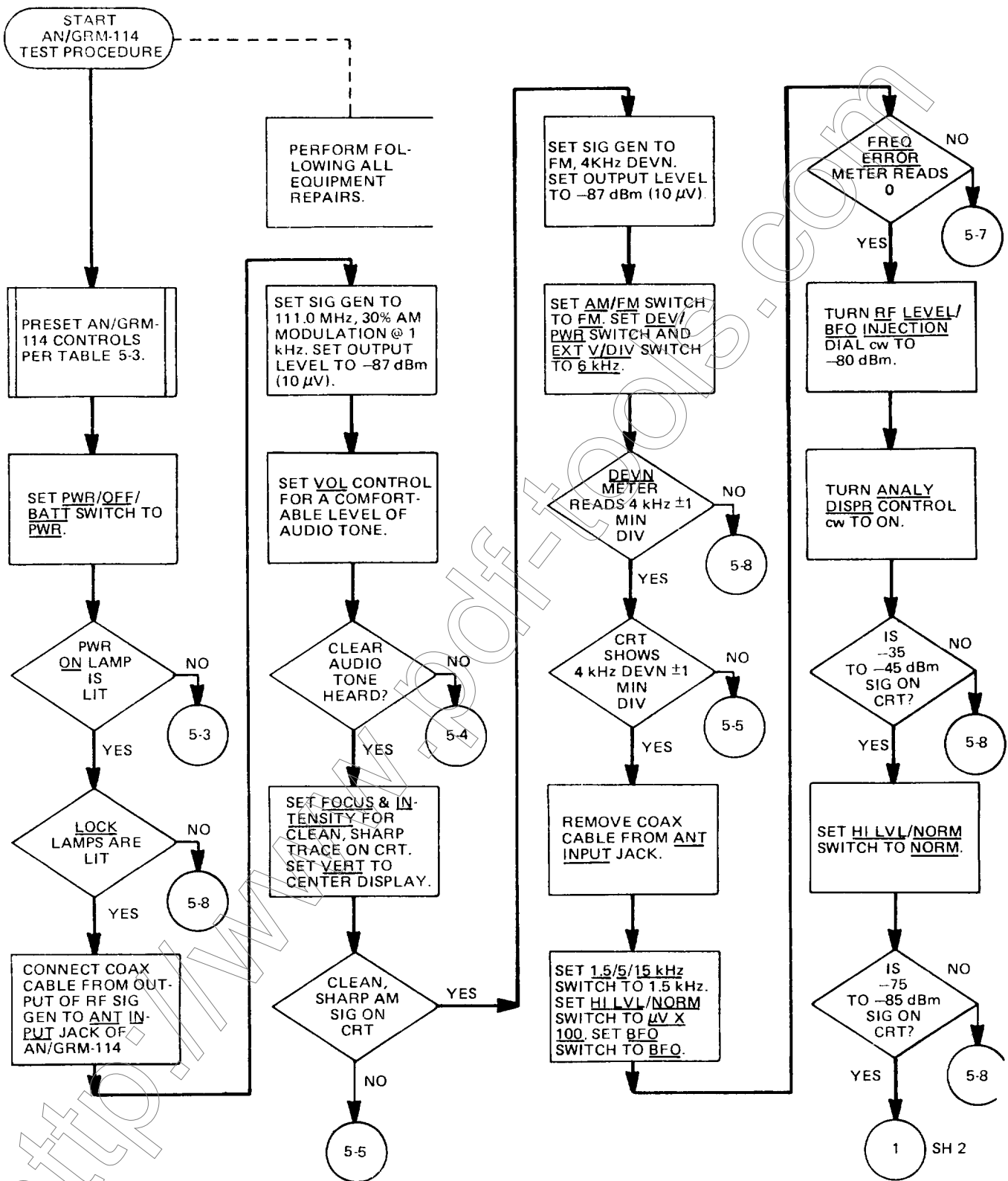


Figure 5-2. AN/GRM-114 performance test (sheet 1 of 13).

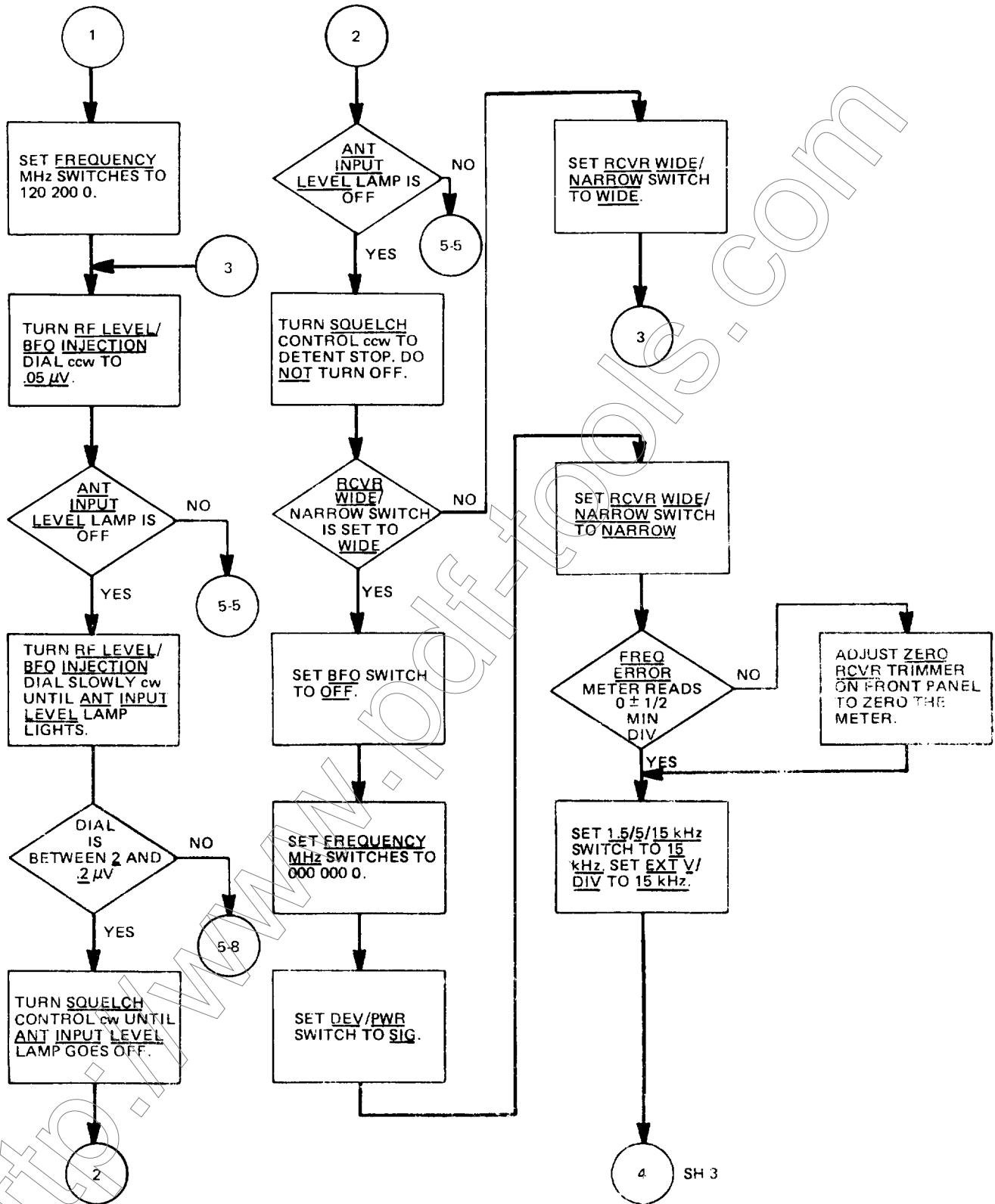


Figure 5-2. AN/GRM-114 performance test (sheet 2 of 13).



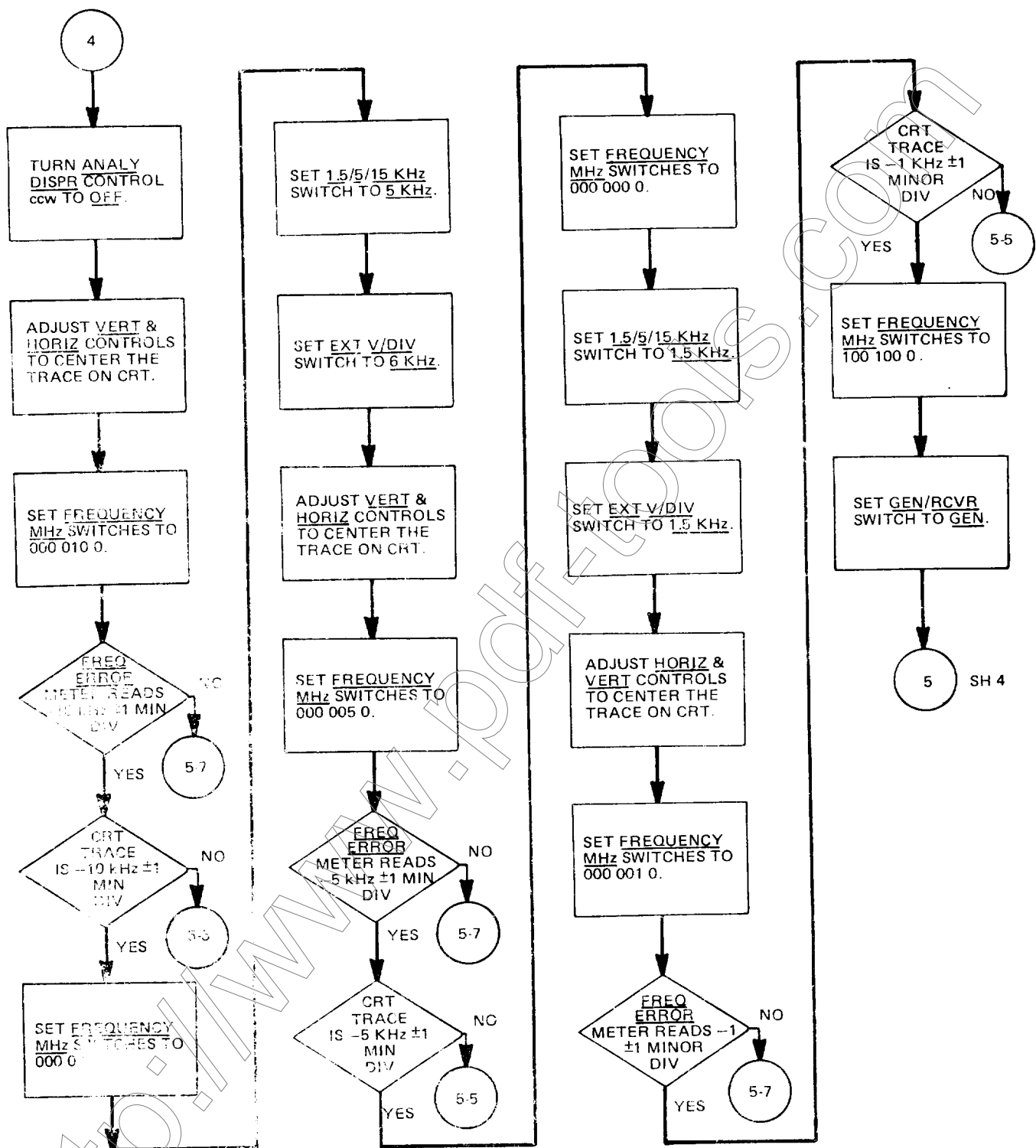


Figure 5-2. AN/DRM-114 performance test (sheet 3 of 13)

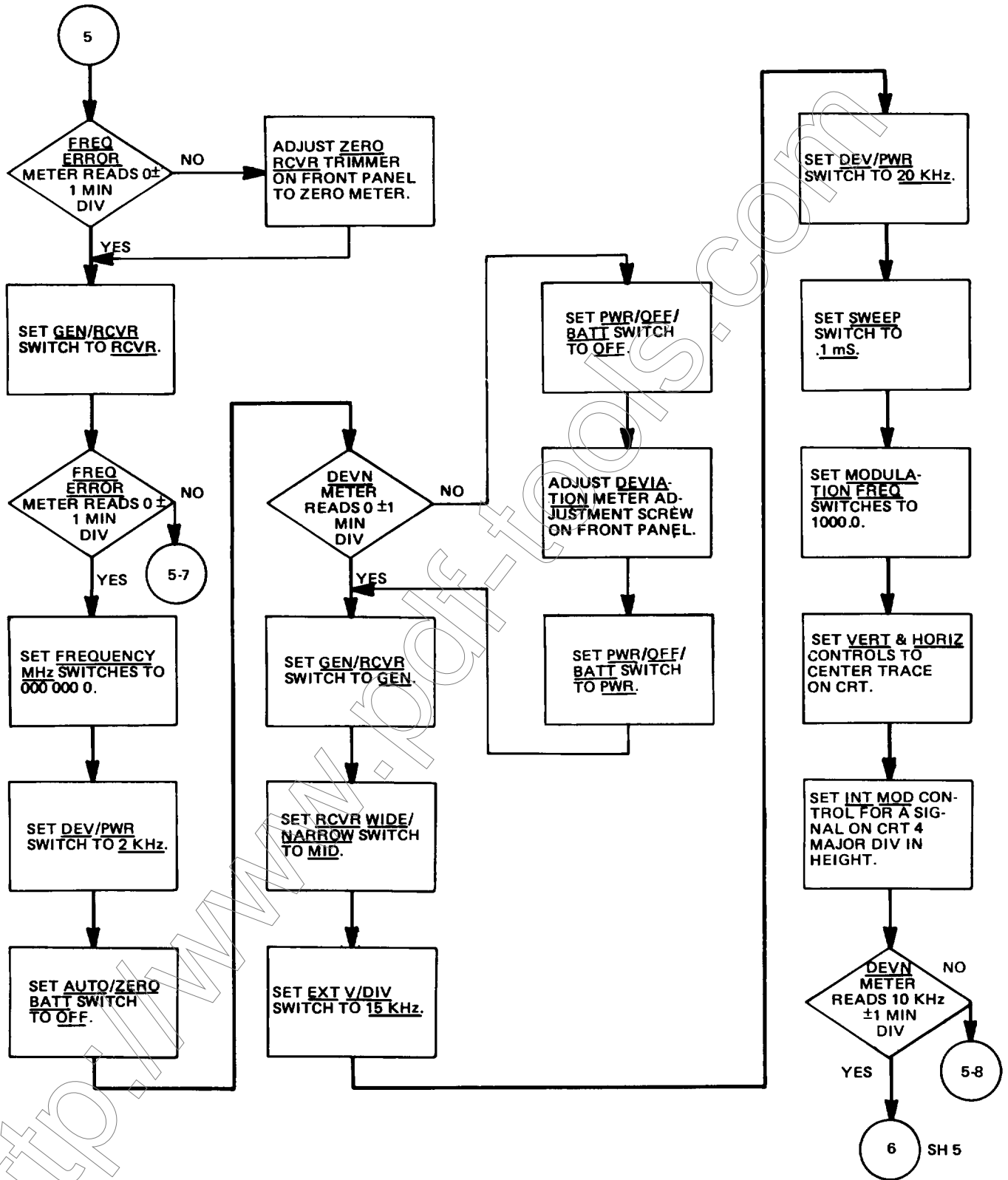


Figure 5-2. AN/GRM-114 performance test (sheet 4 of 13).

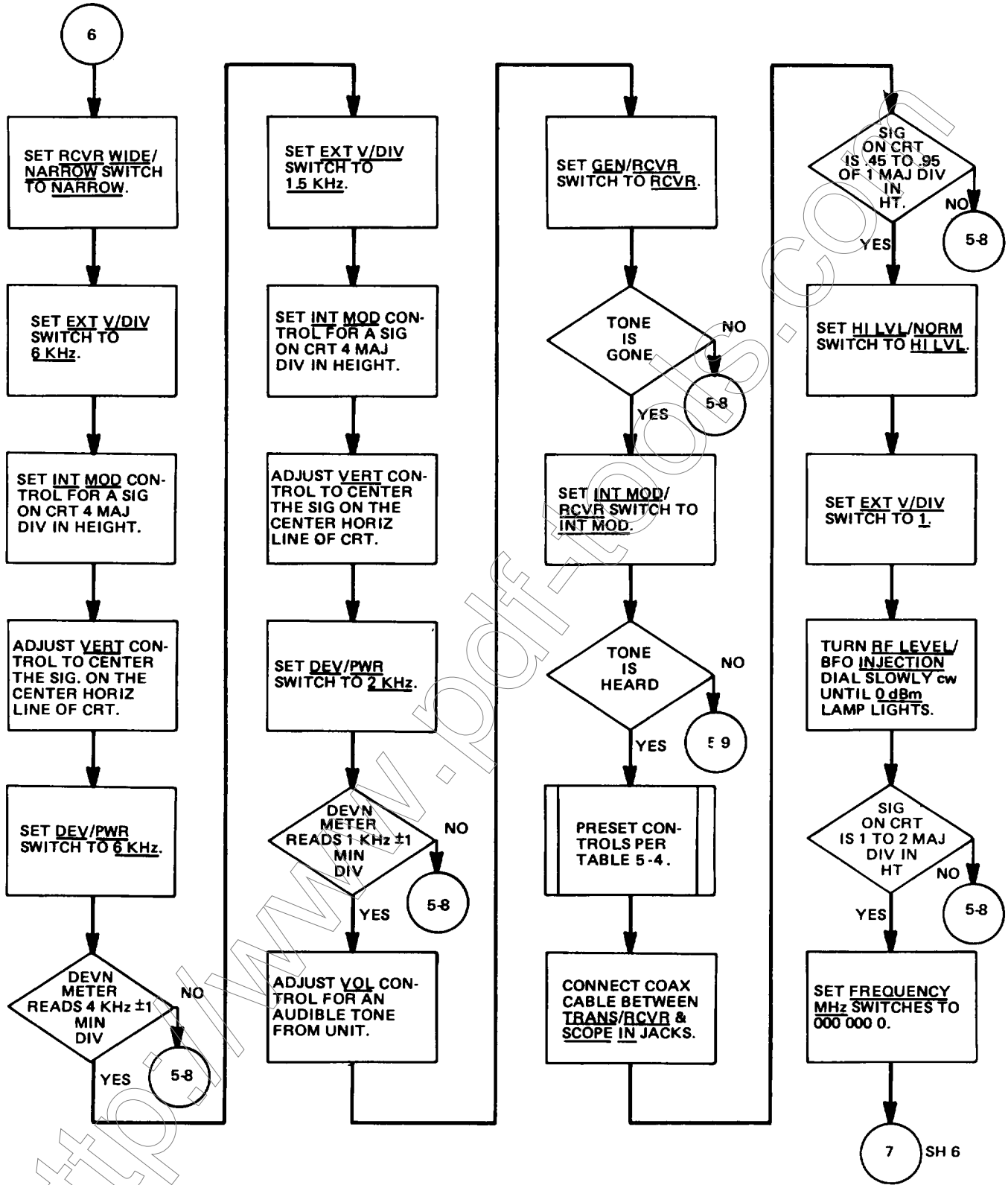


Figure 5-2. AN/GRM-114 performance test (sheet 5 of 13).

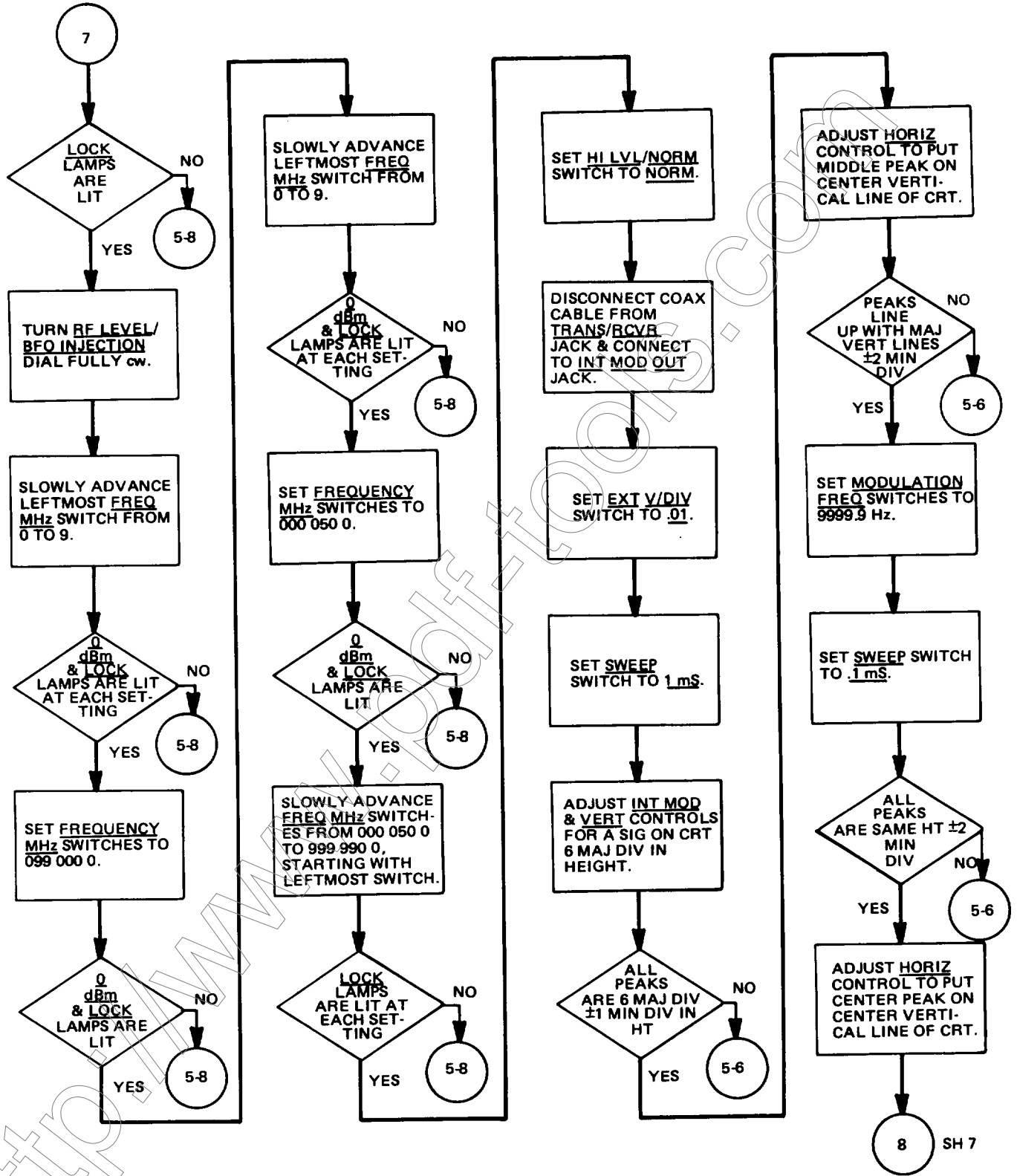


Figure 5-2. AN/GRM-114 performance test (sheet 6 of 13).

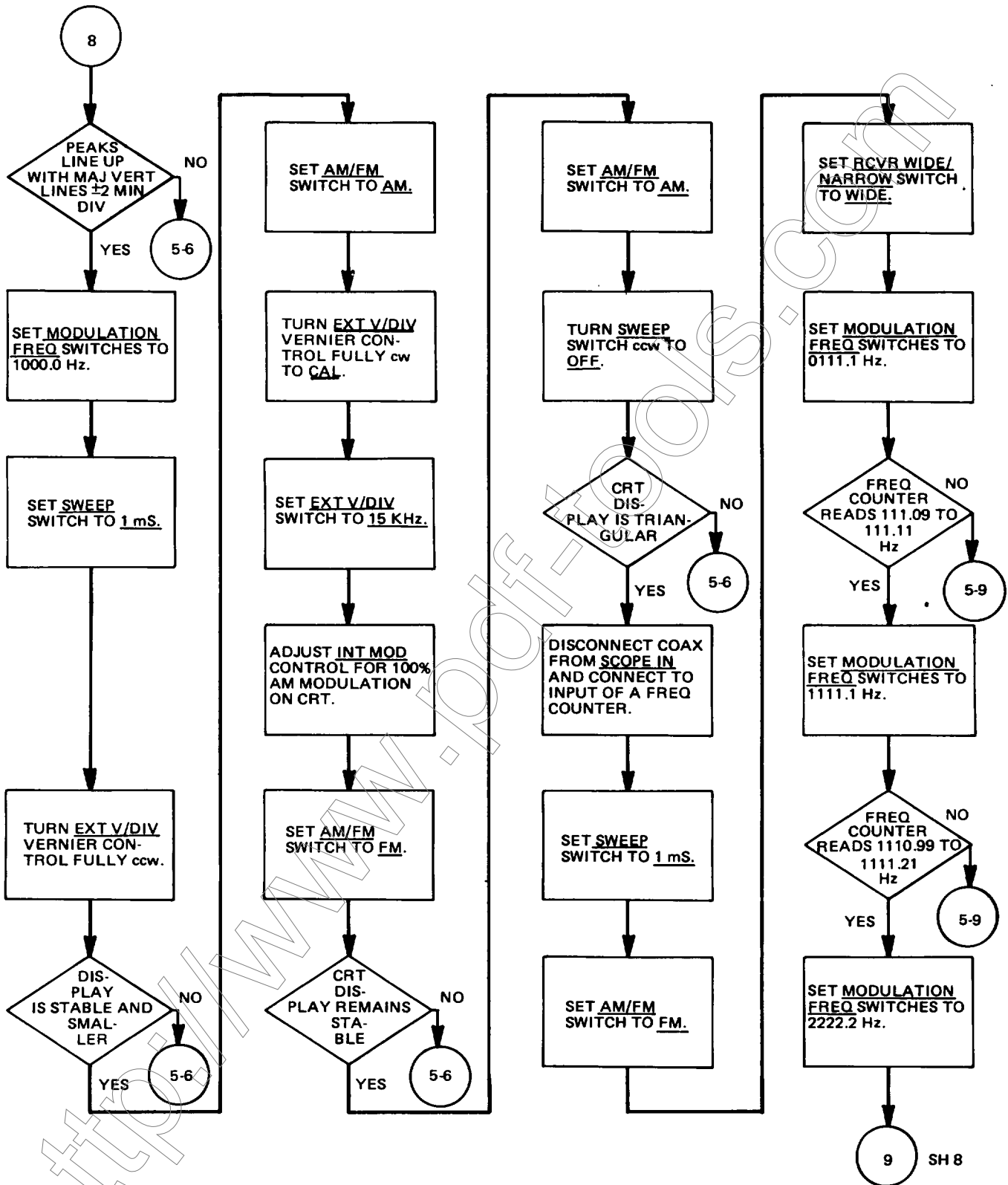


Figure 5-2. AN/GRM-114 performance test (sheet 7 of 13).

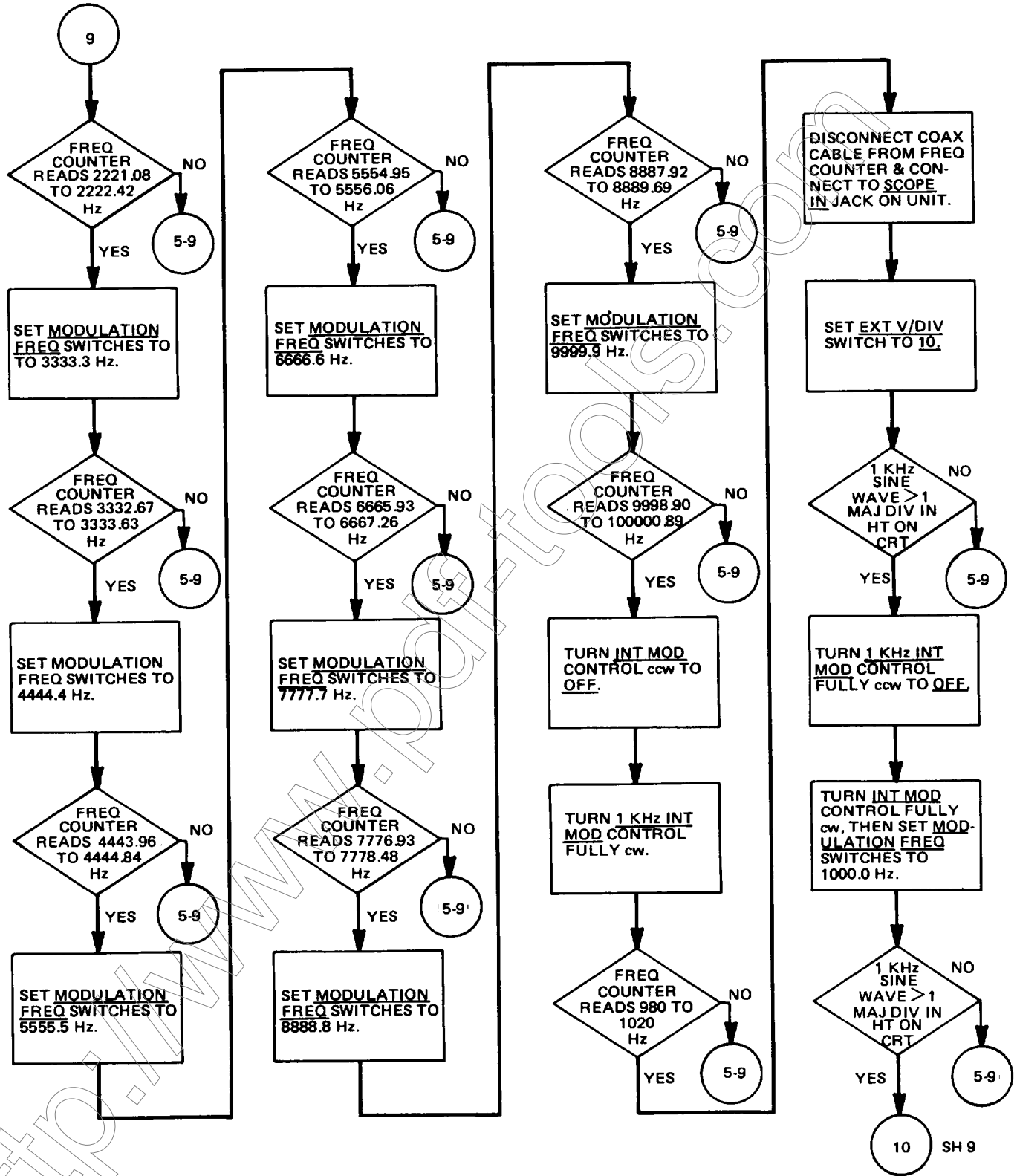


Figure 5-2. AN/GRM-114 performance test (sheet 8 of 13).

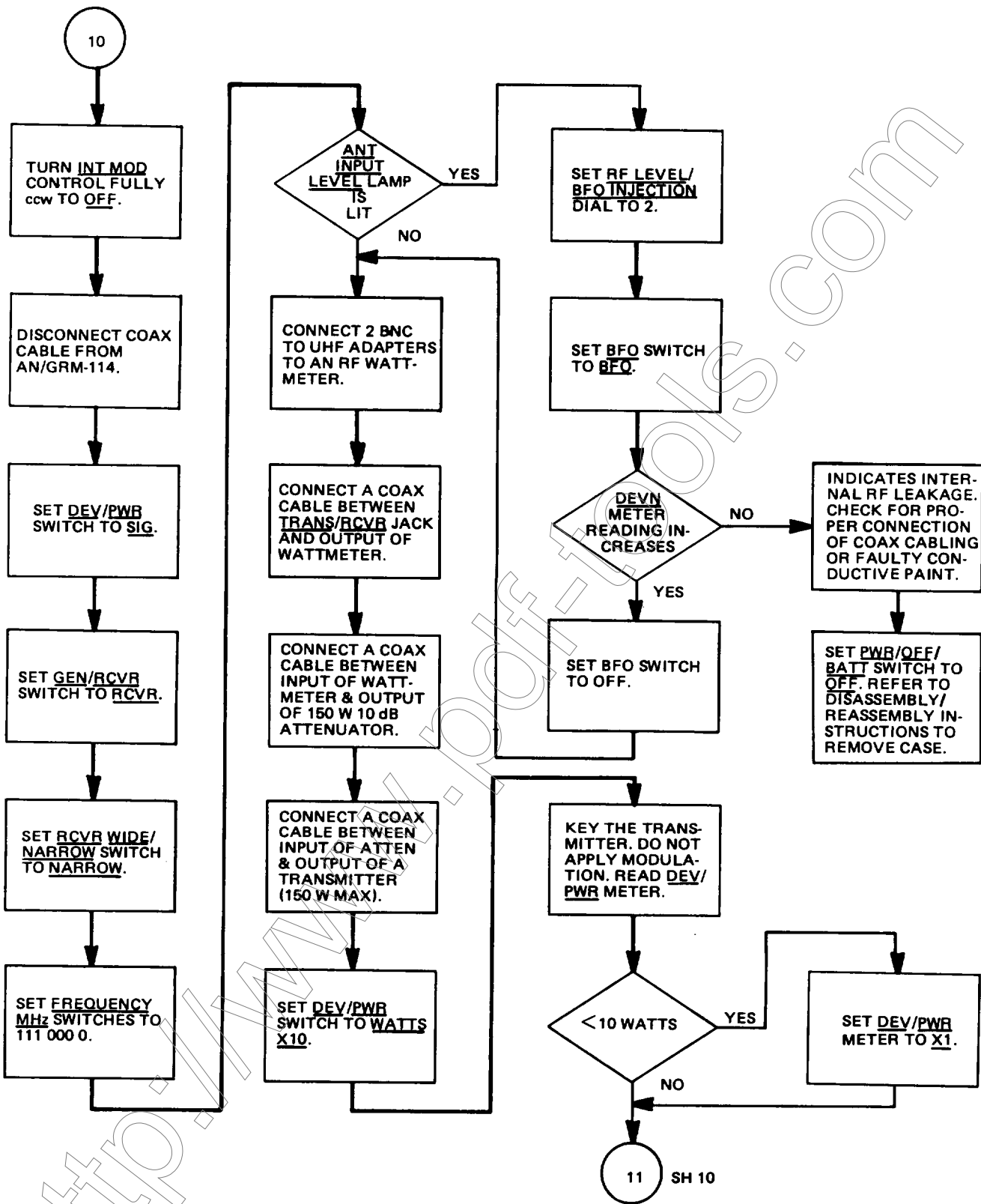


Figure 5-2. AN/GRM-114 performance test (sheet 9 of 13).

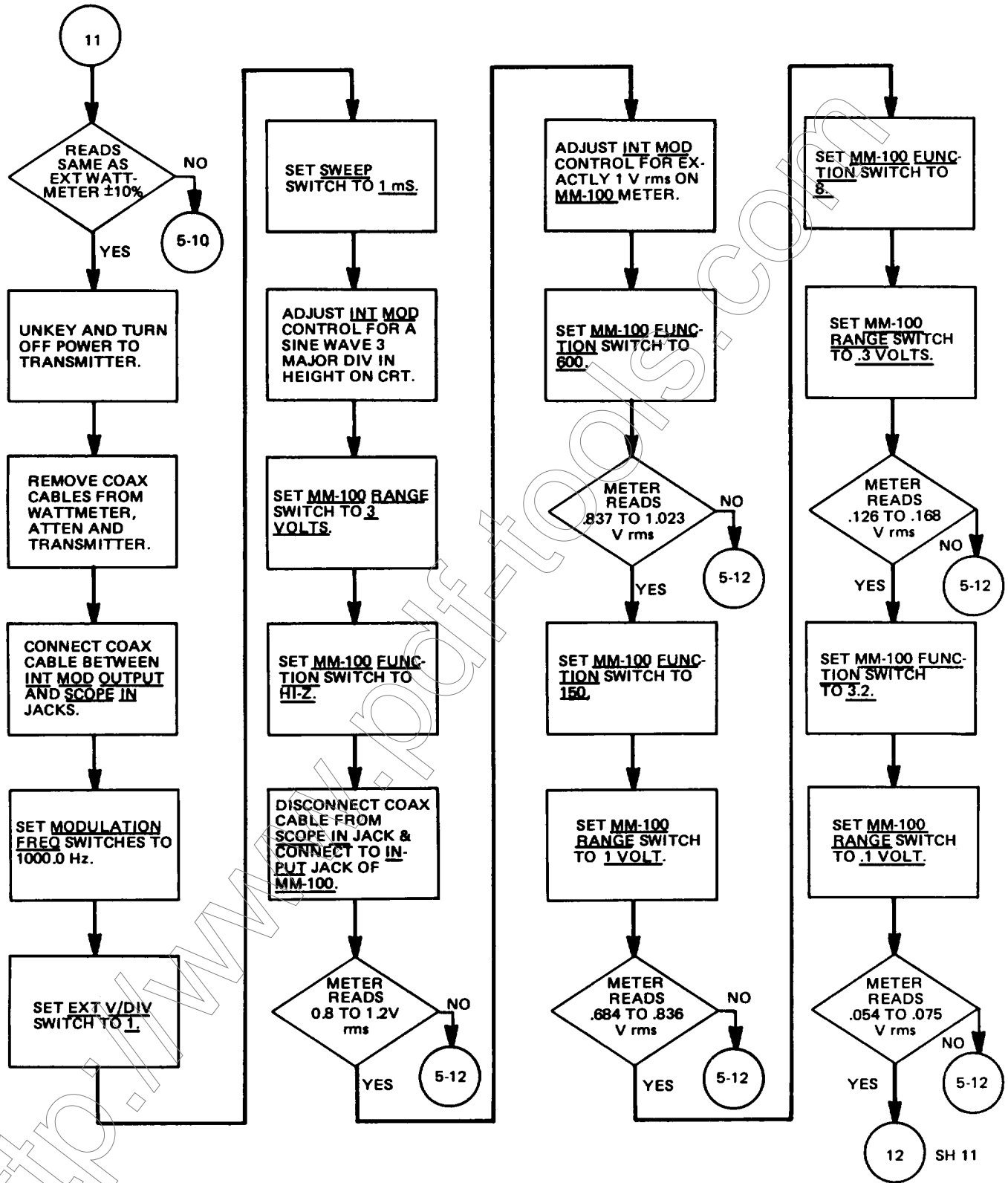


Figure 5-2. AN/GRM-114 performance test (sheet 10 of 13),



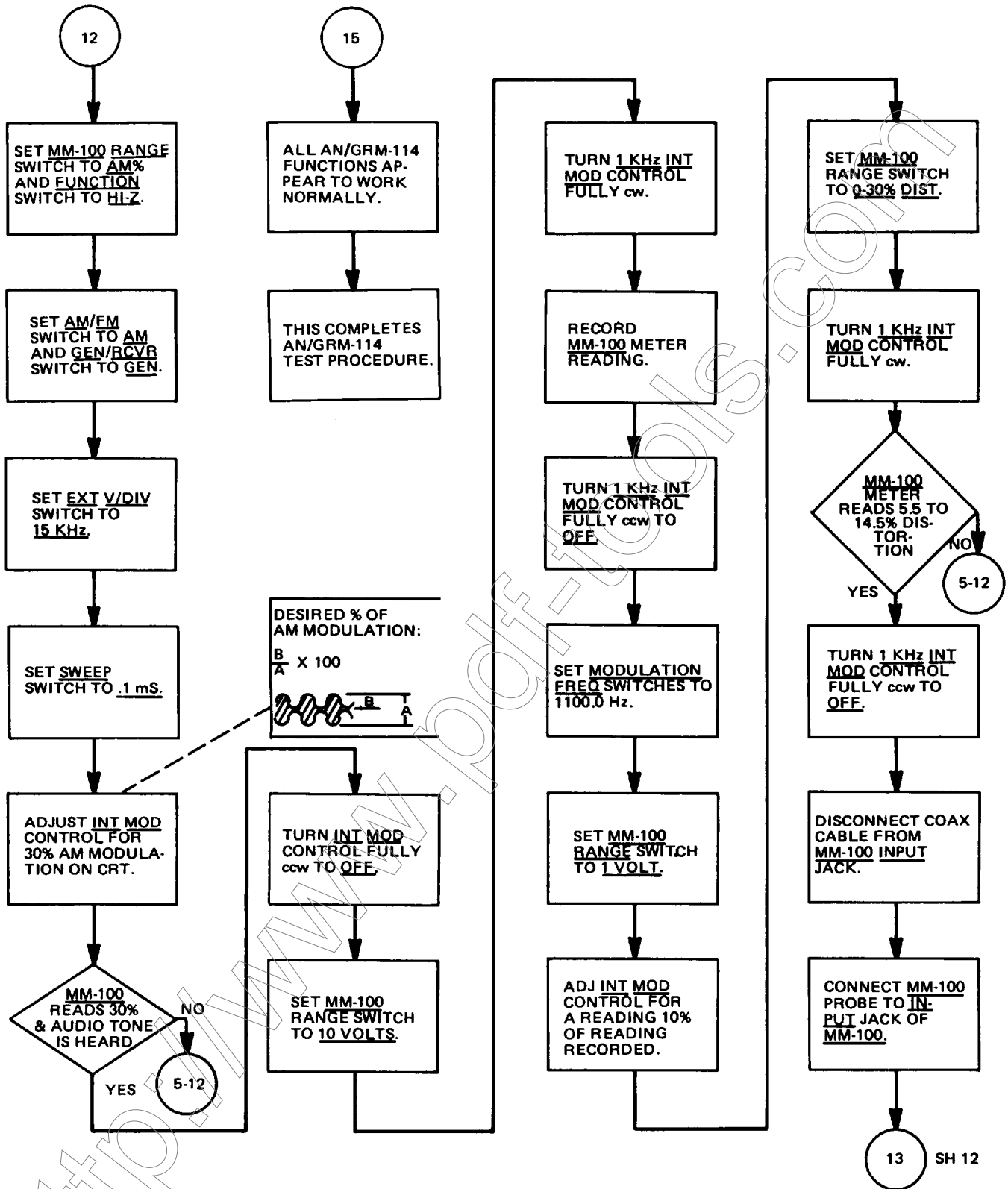


Figure 5-2. AN/GRM-114 performance test (sheet 11 of 13)

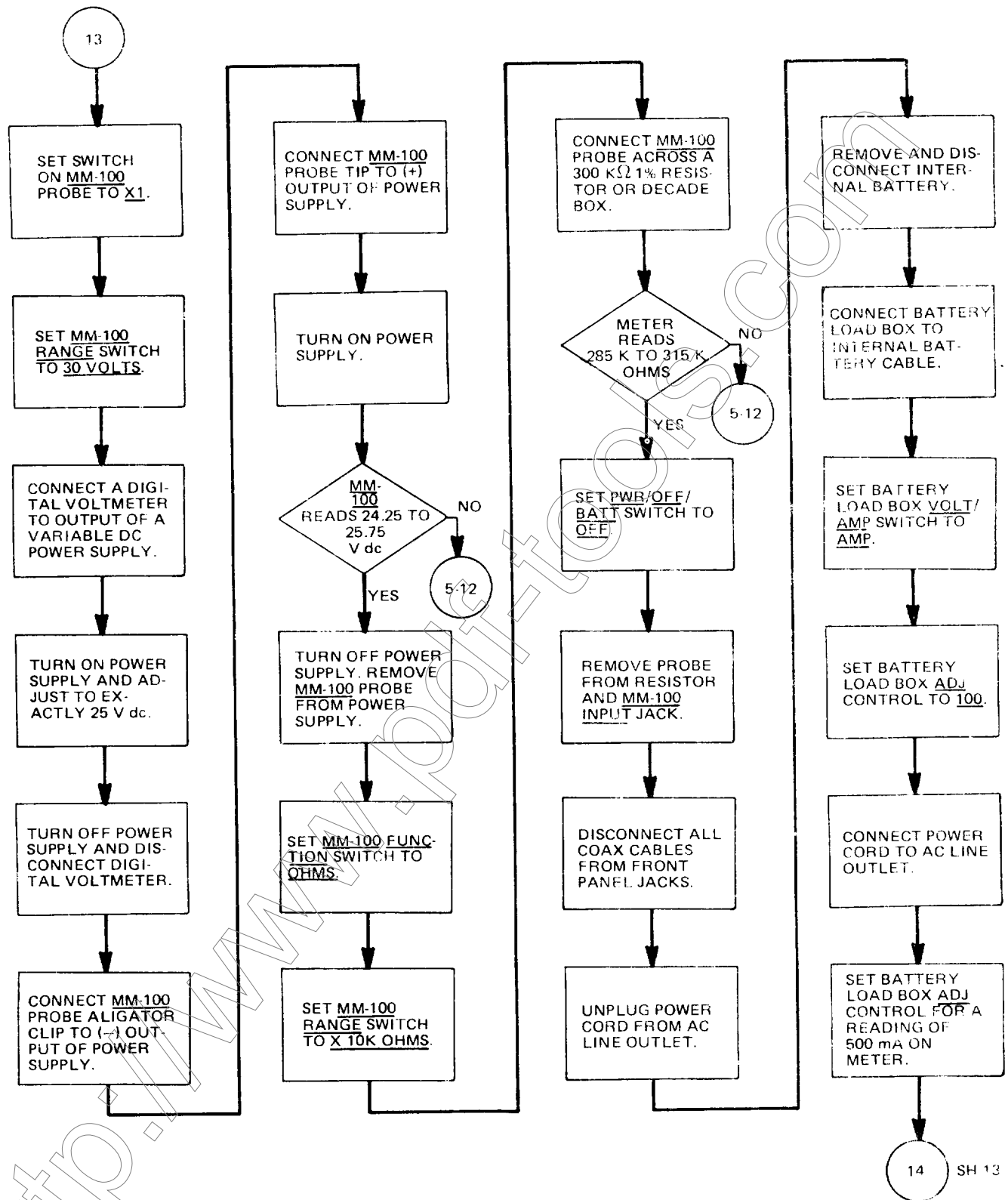


Figure 5-2. AN/GRM-114 performance test (sheet 12 of 13)

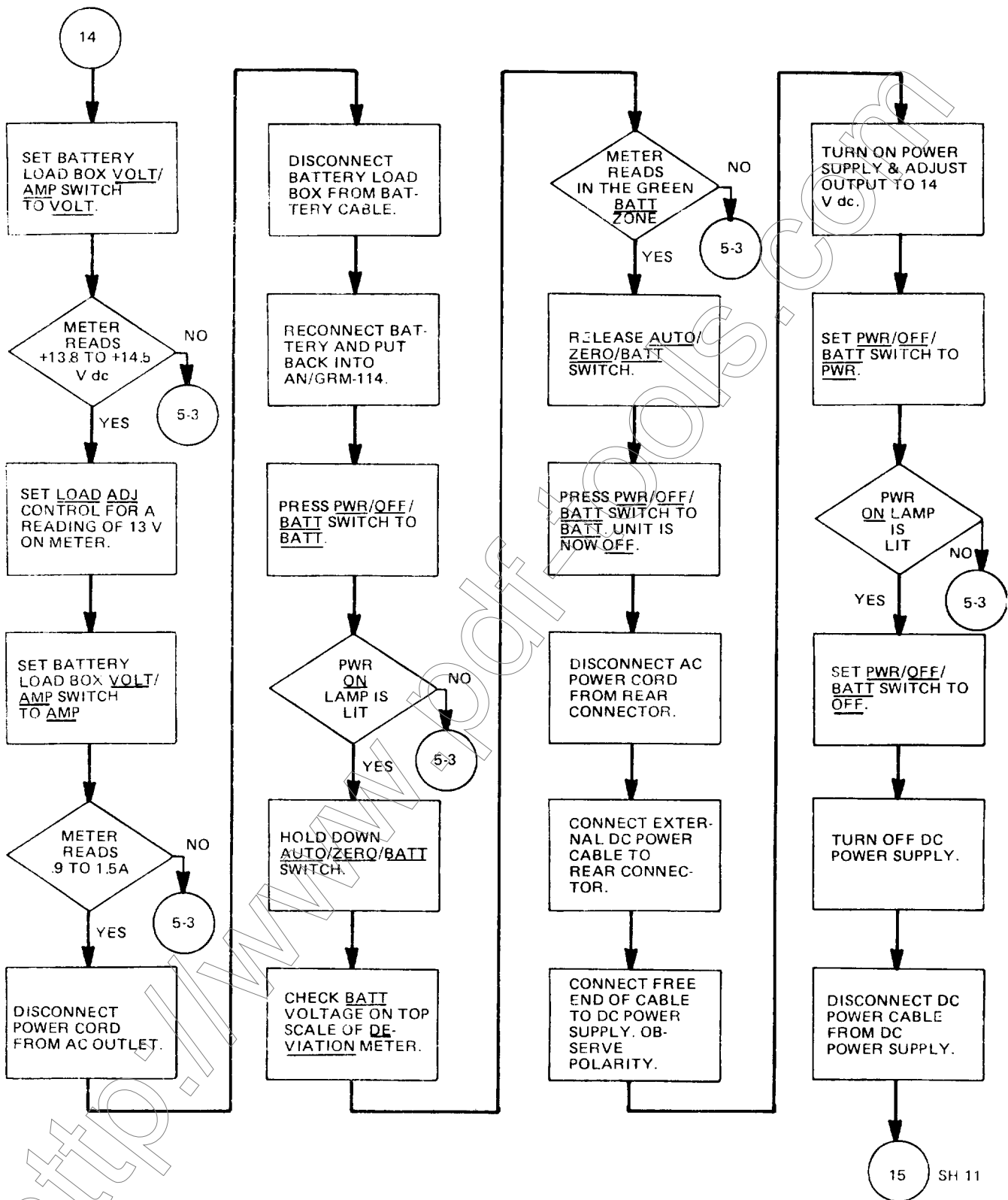


Figure 5-2. AN/GRM-114 performance test (sheet 13 of 13)

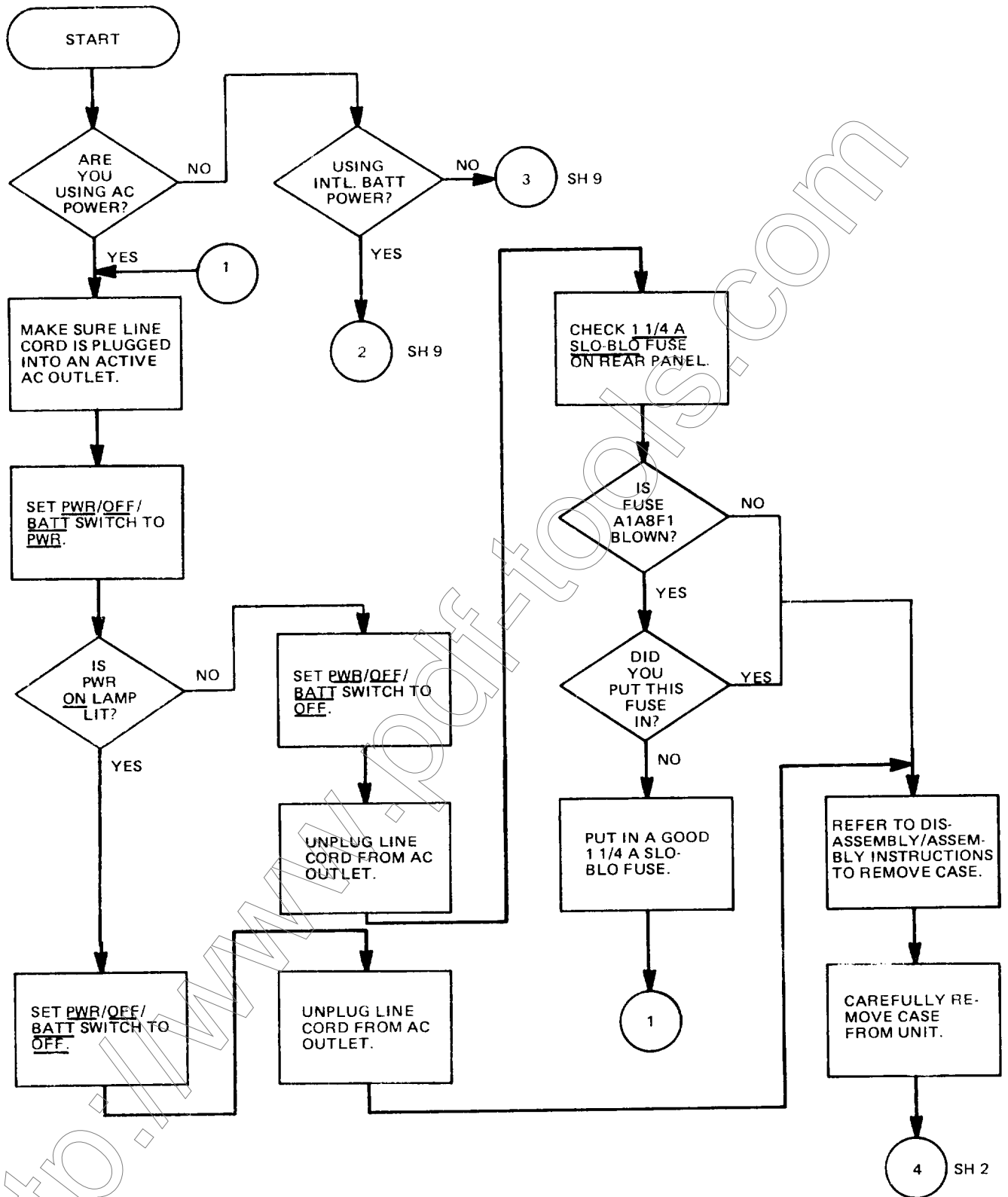


Figure 5-3. Power supply troubleshooting (sheet 1 of 16).

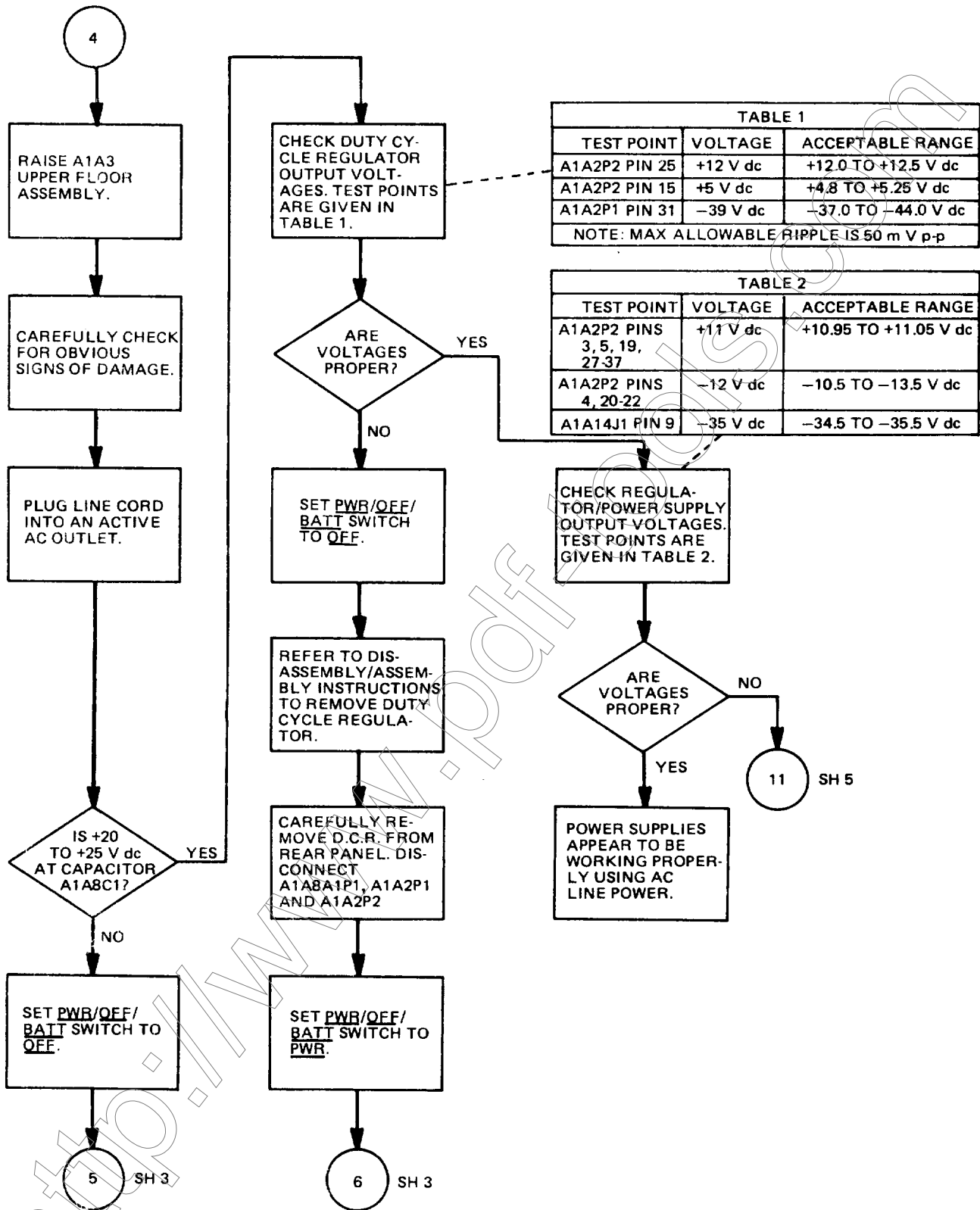


Figure 5-3. Power Supply troubleshooting (sheet 2 of 16).

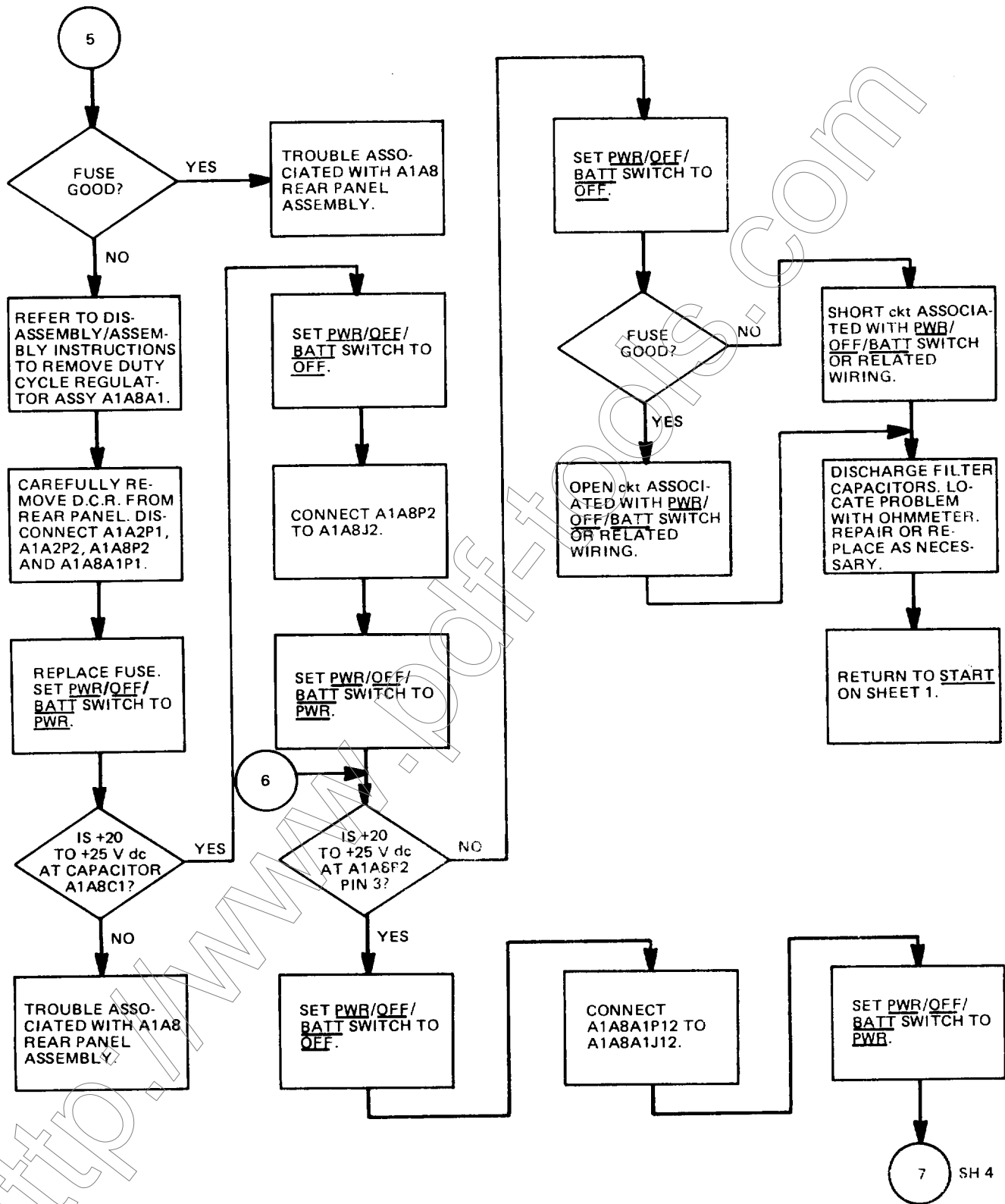


Figure 5-3. Power supply troubleshooting (sheet 3 of 16).

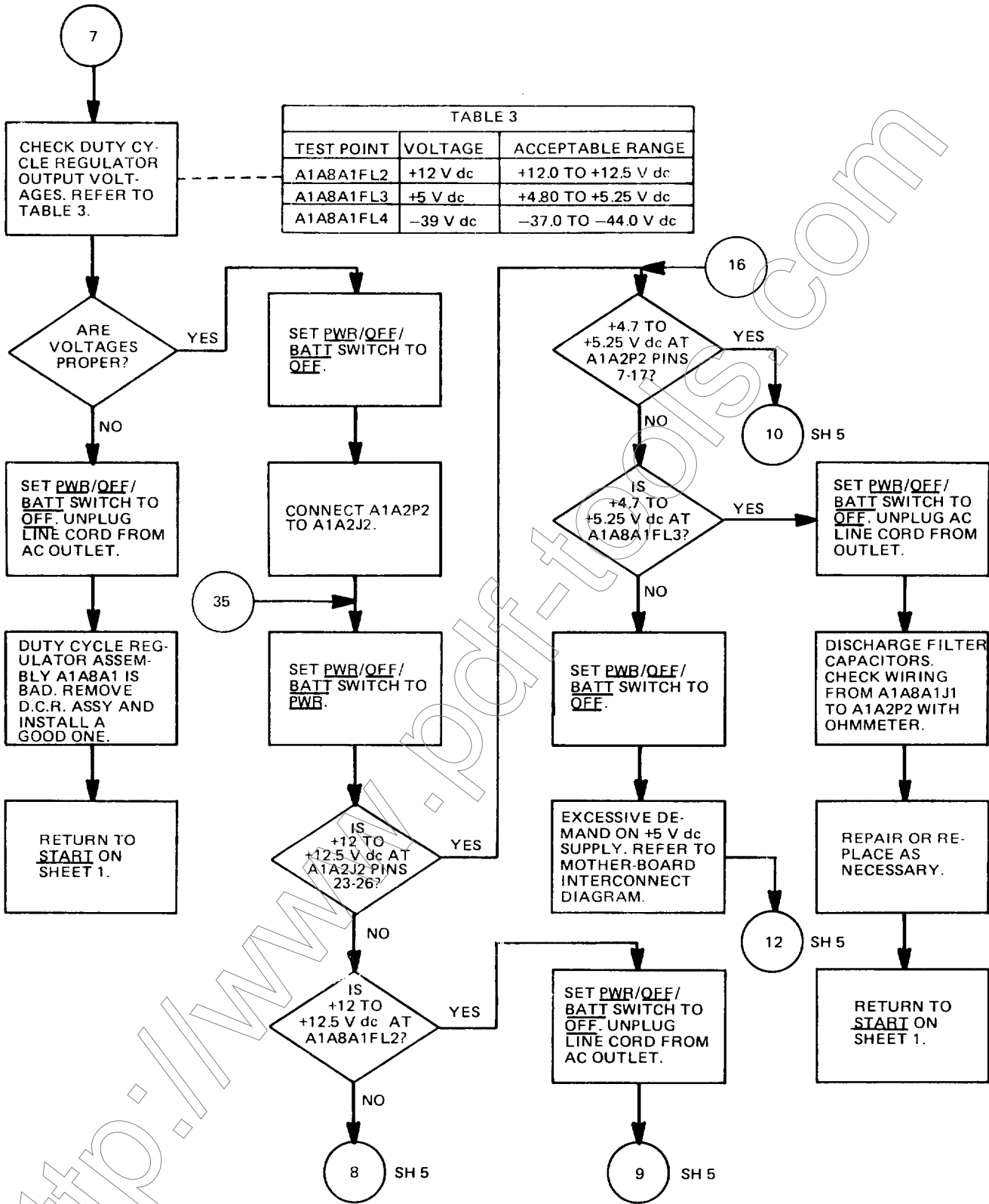


Figure 5-3. Power supply troubleshooting (sheet 4 of 16).

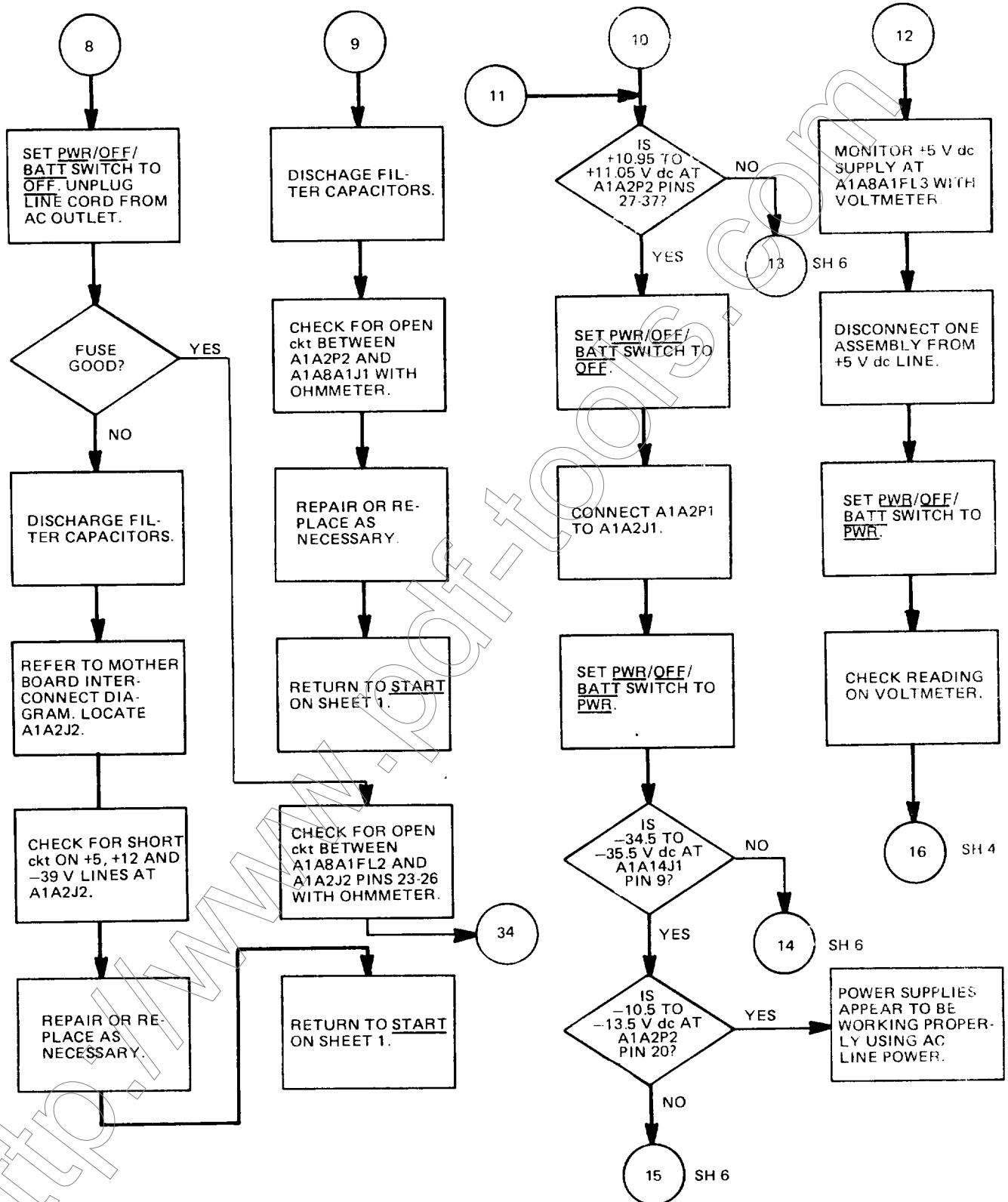


Figure 5-3. Power supply troubleshooting (sheet 5 of 16).



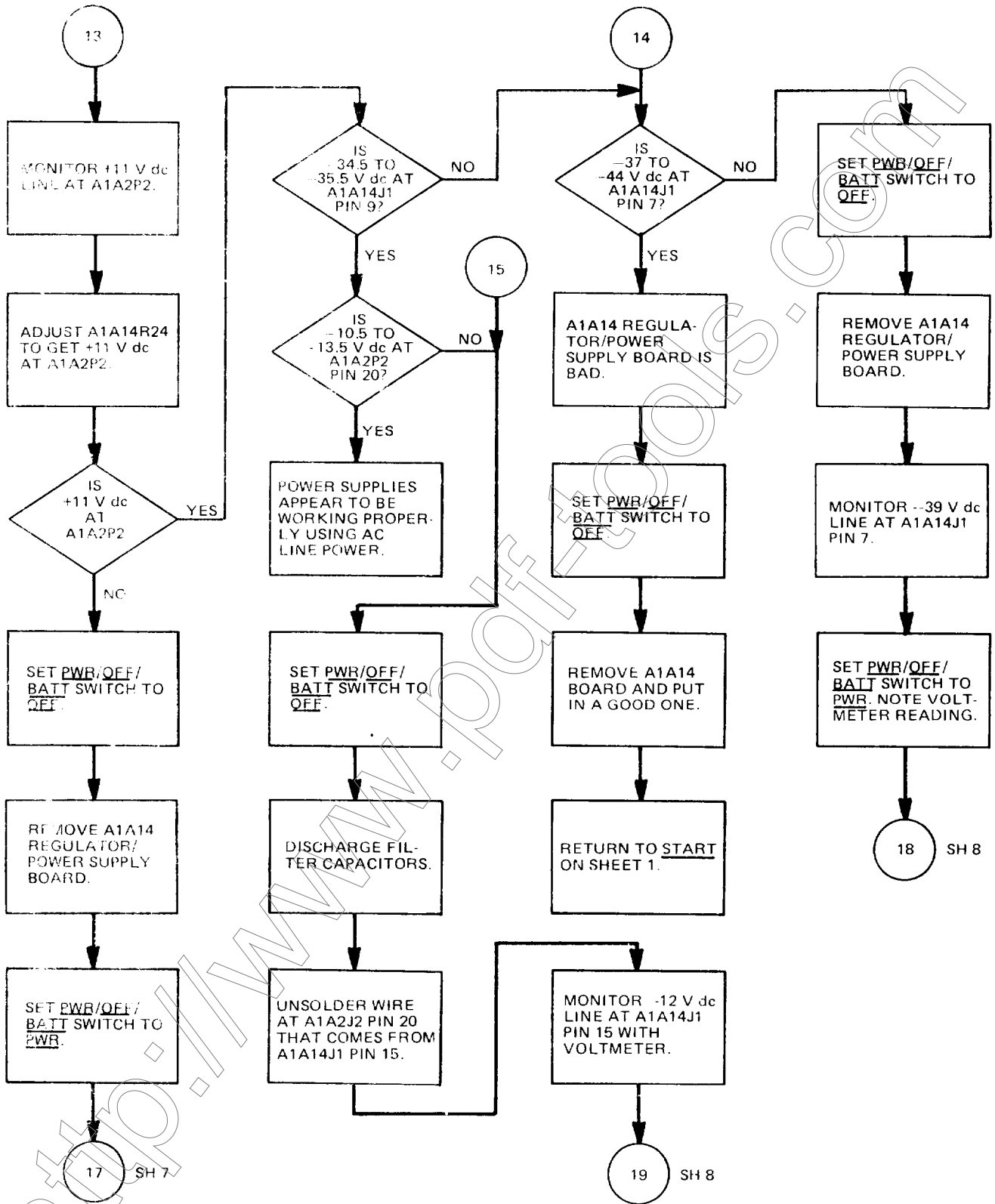


Figure 5-3. Power supply troubleshooting (sheet 6 of 16).

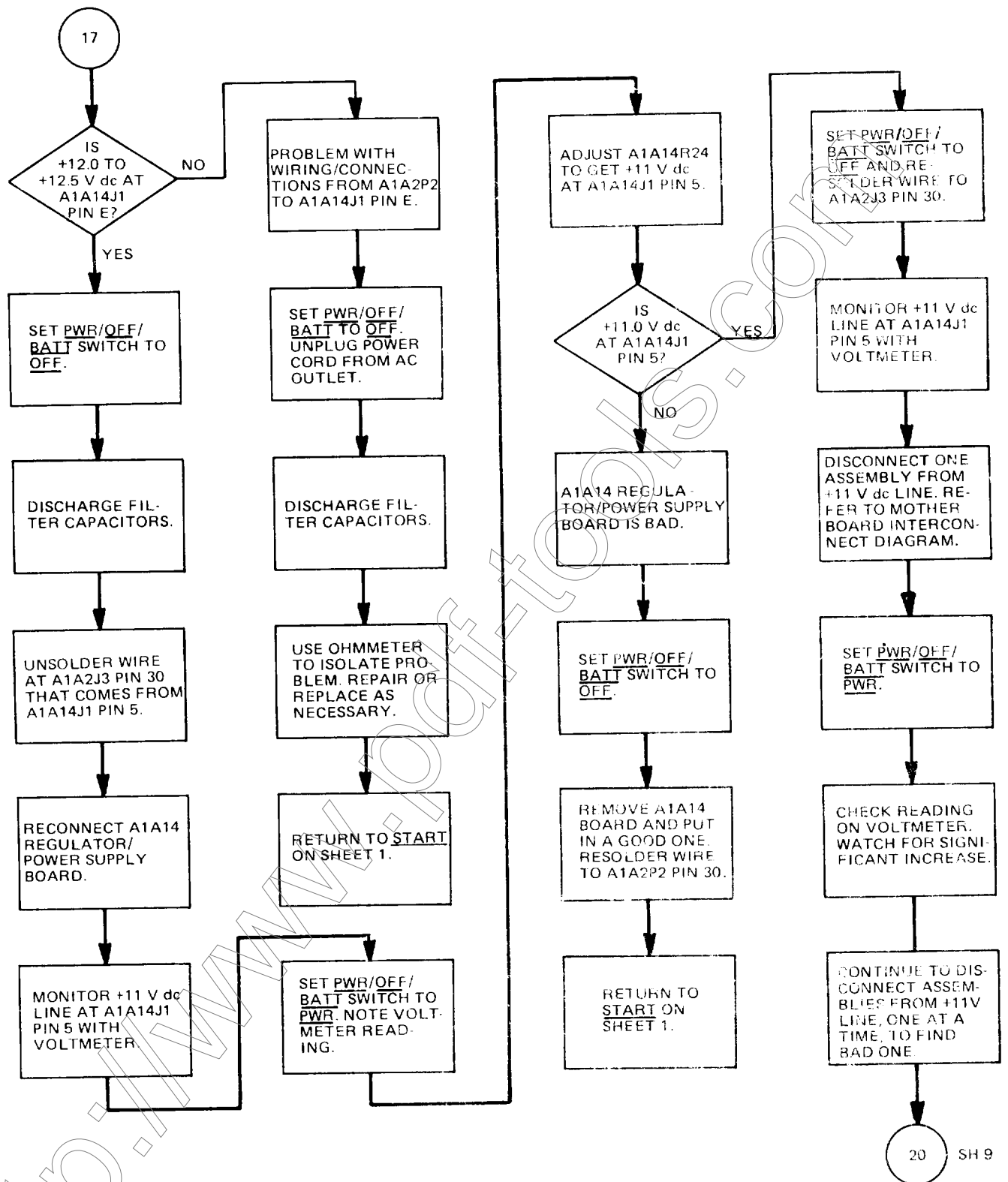


Figure 5-3. Power supply troubleshooting (sheet 6 of 16)

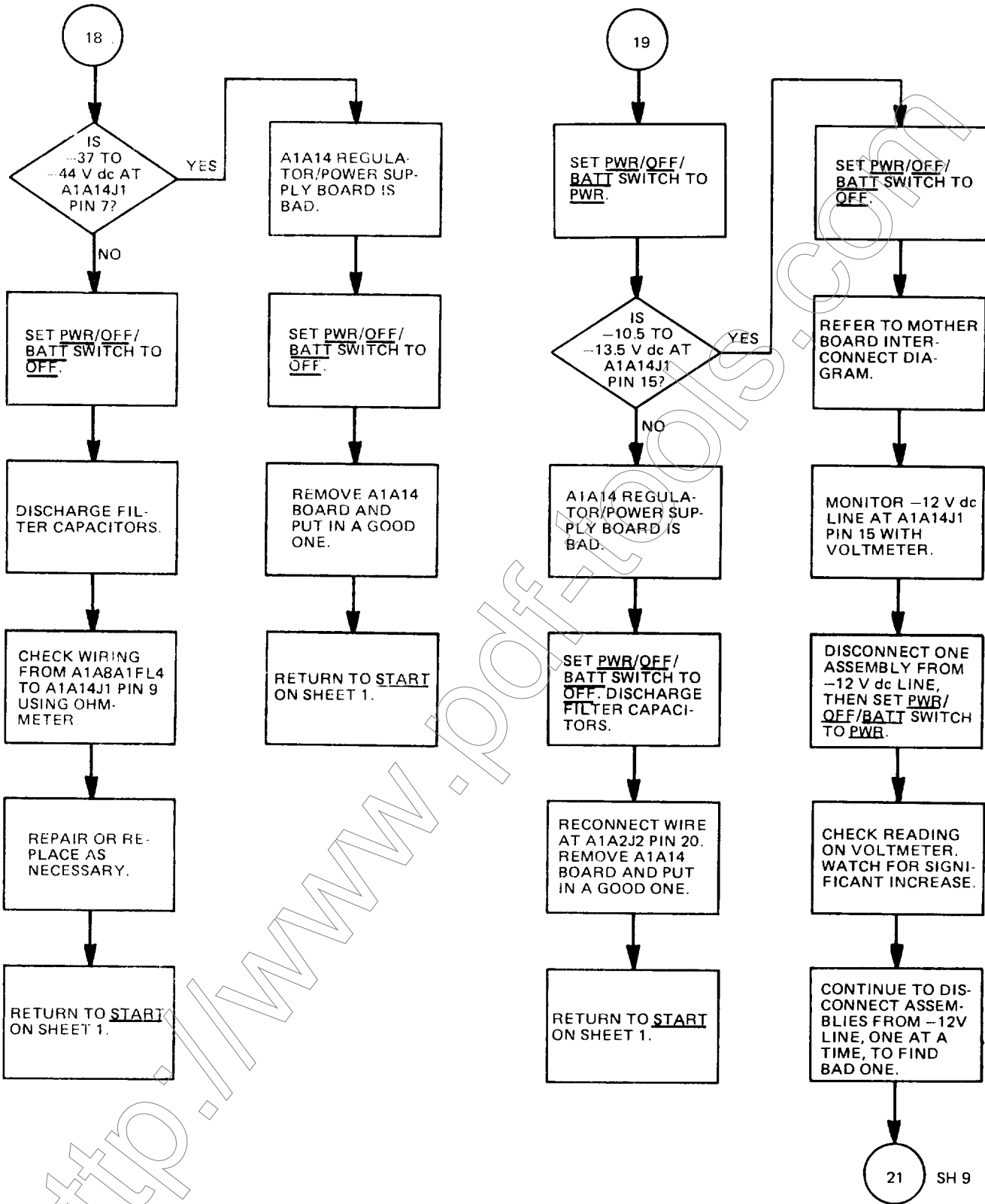


Figure 5-3, Power supply troubleshooting (sheet 8 of 16).

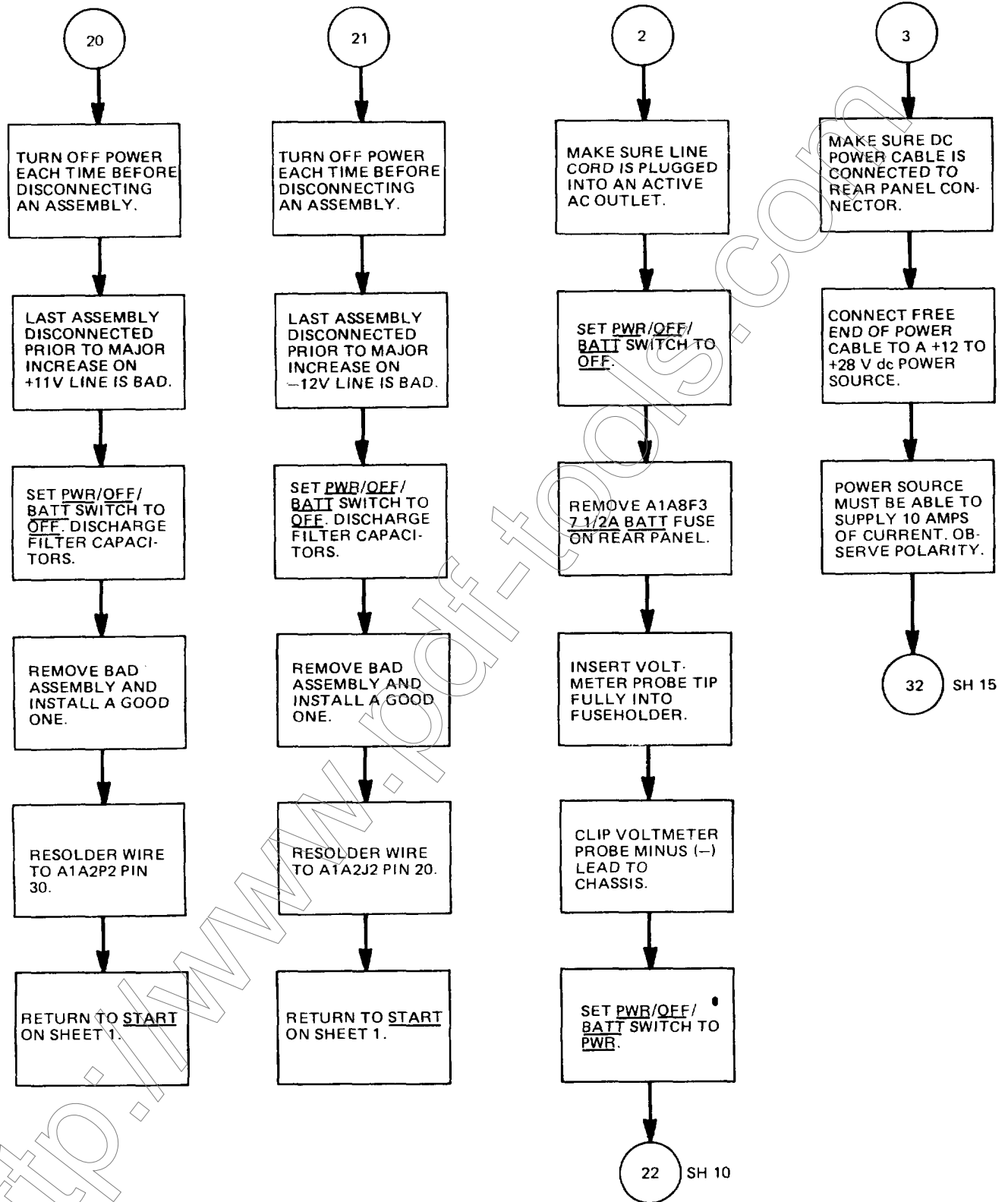


Figure 5-3. Power supply troubleshooting (sheet 9 of 16).

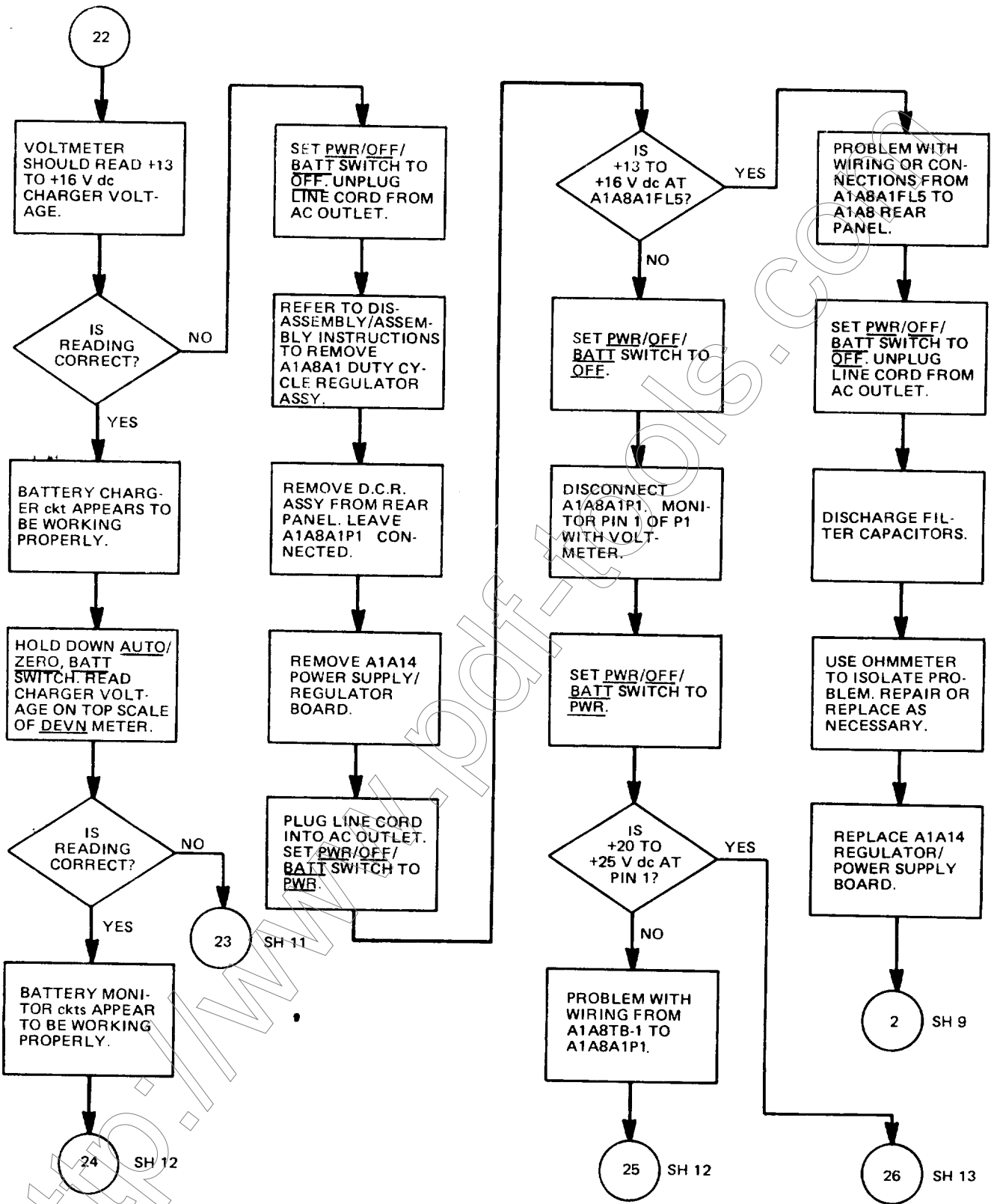


Figure 5-3. Power supply troubleshooting (sheet 10 of 16).

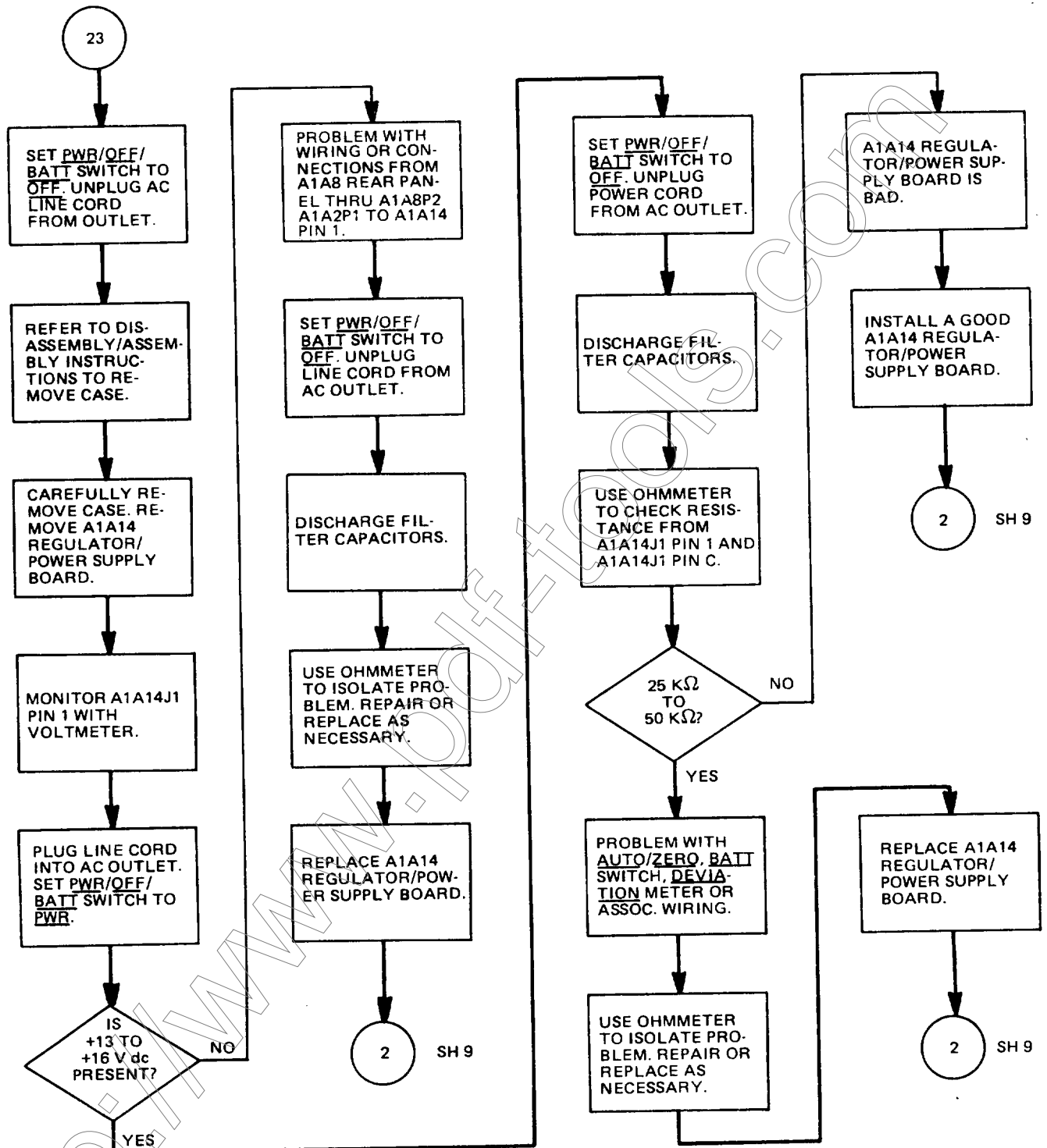


Figure 5-3. Power supply troubleshooting (sheet 11 of 16).

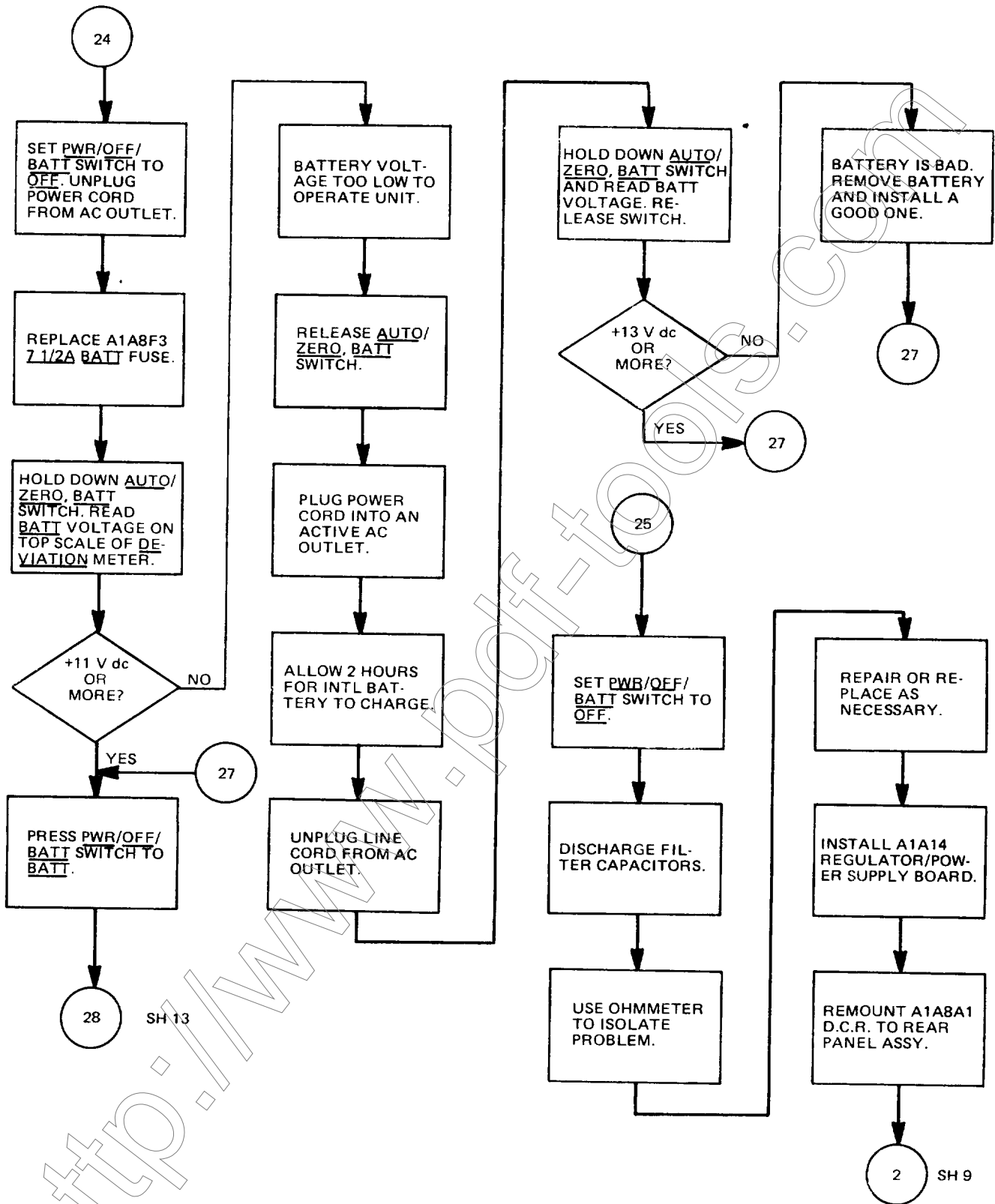


Figure 5-3. Power supply troubleshooting (sheet 12 of 16).





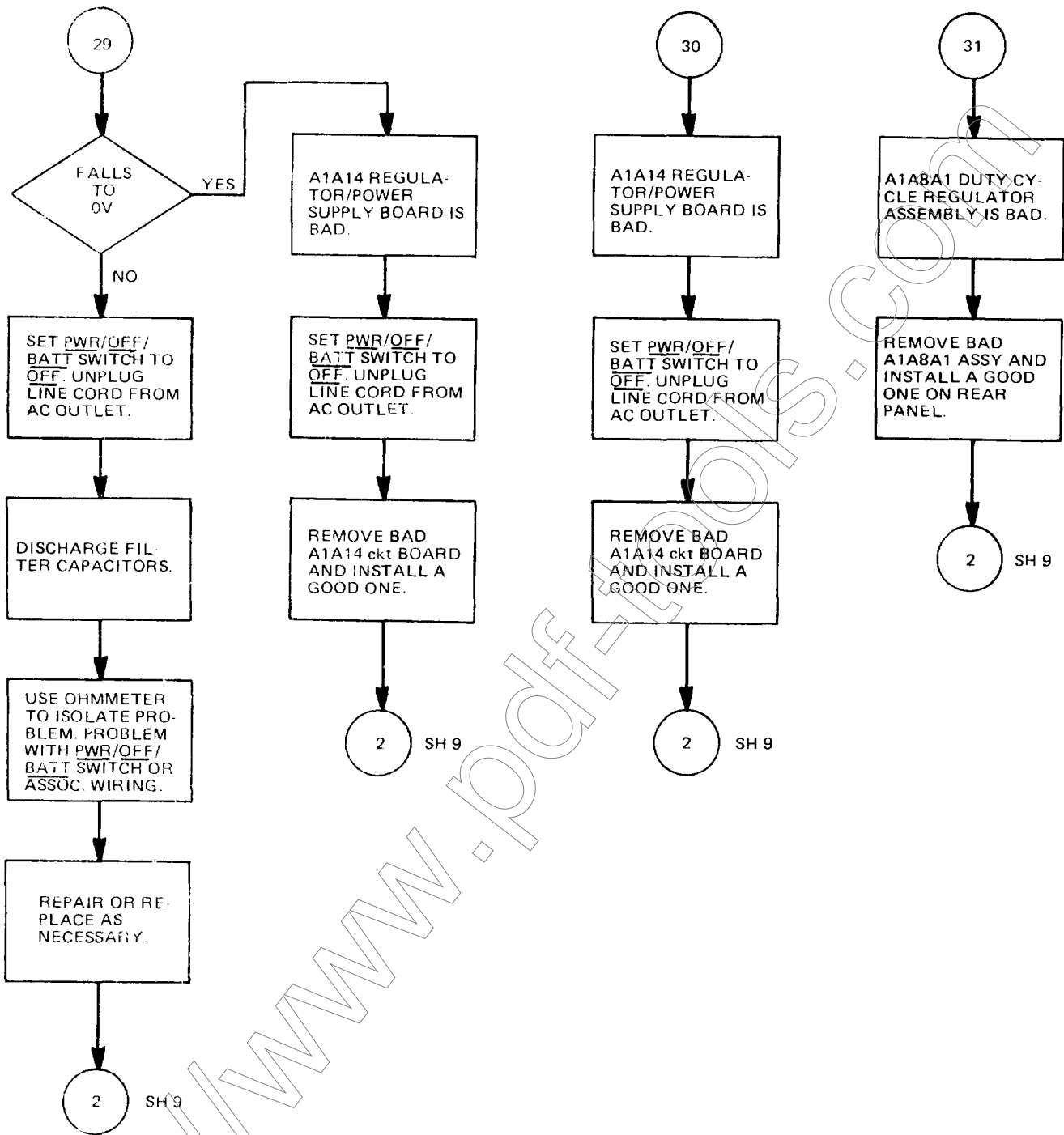


Figure 5-34 Power supply troubleshooting (sheet 14 of 16).

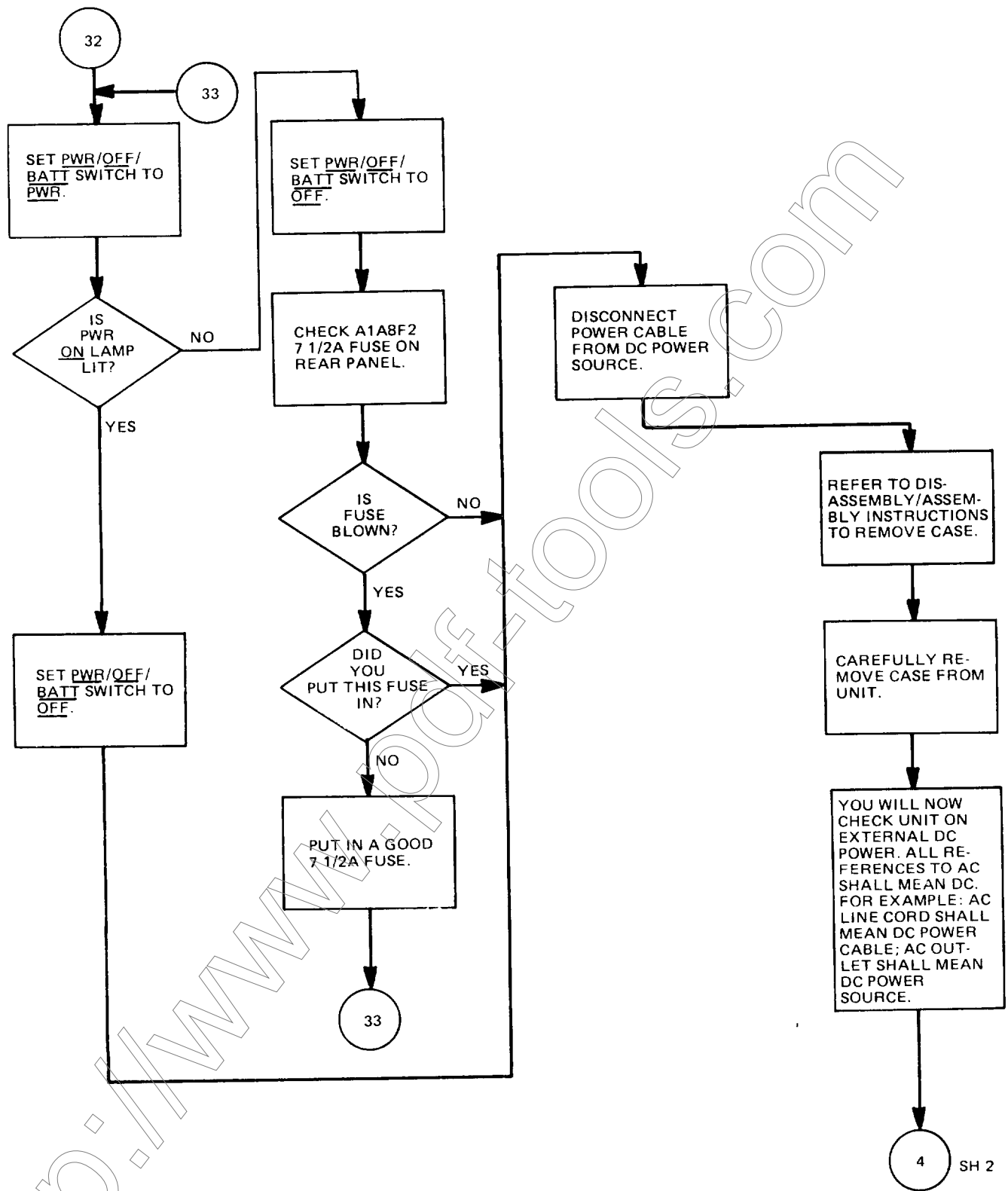


Figure 5-3. Power supply troubleshooting (sheet 15 of 16).

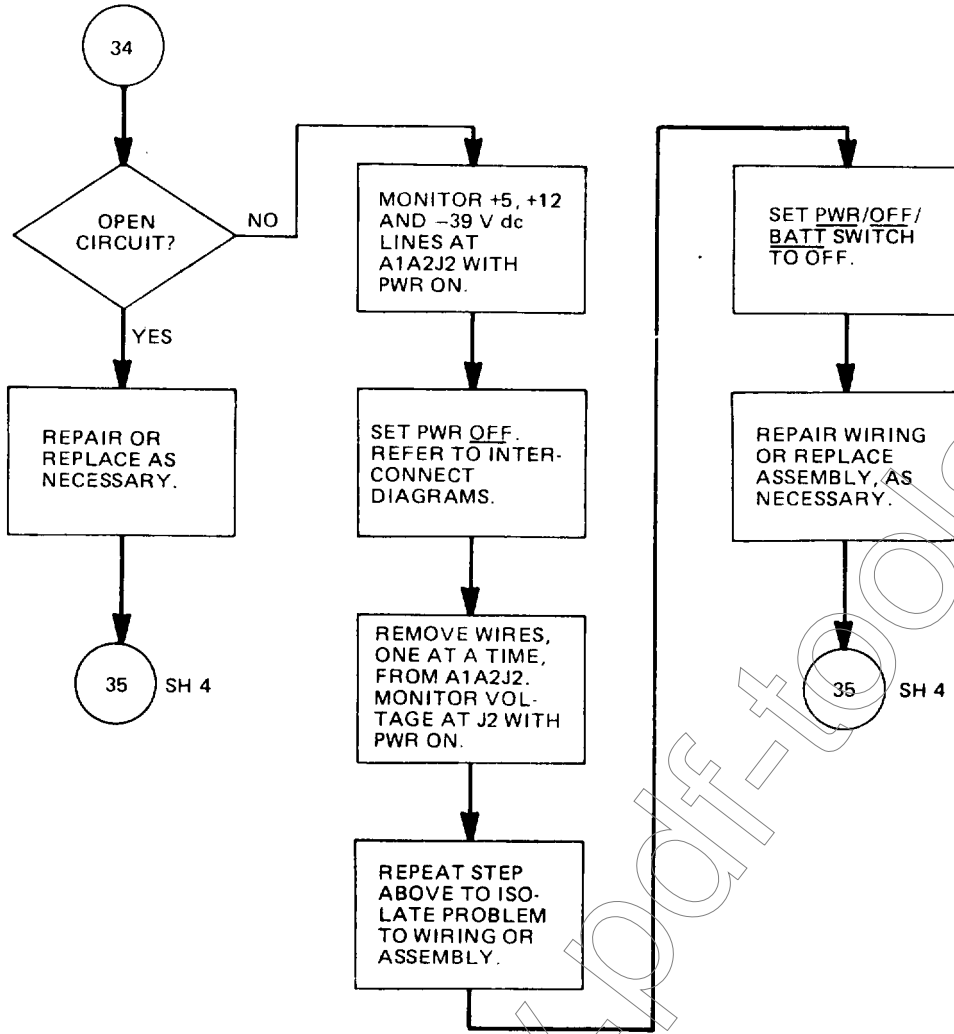


Figure 5-3. Power supply troubleshooting (sheet 16 of 16).

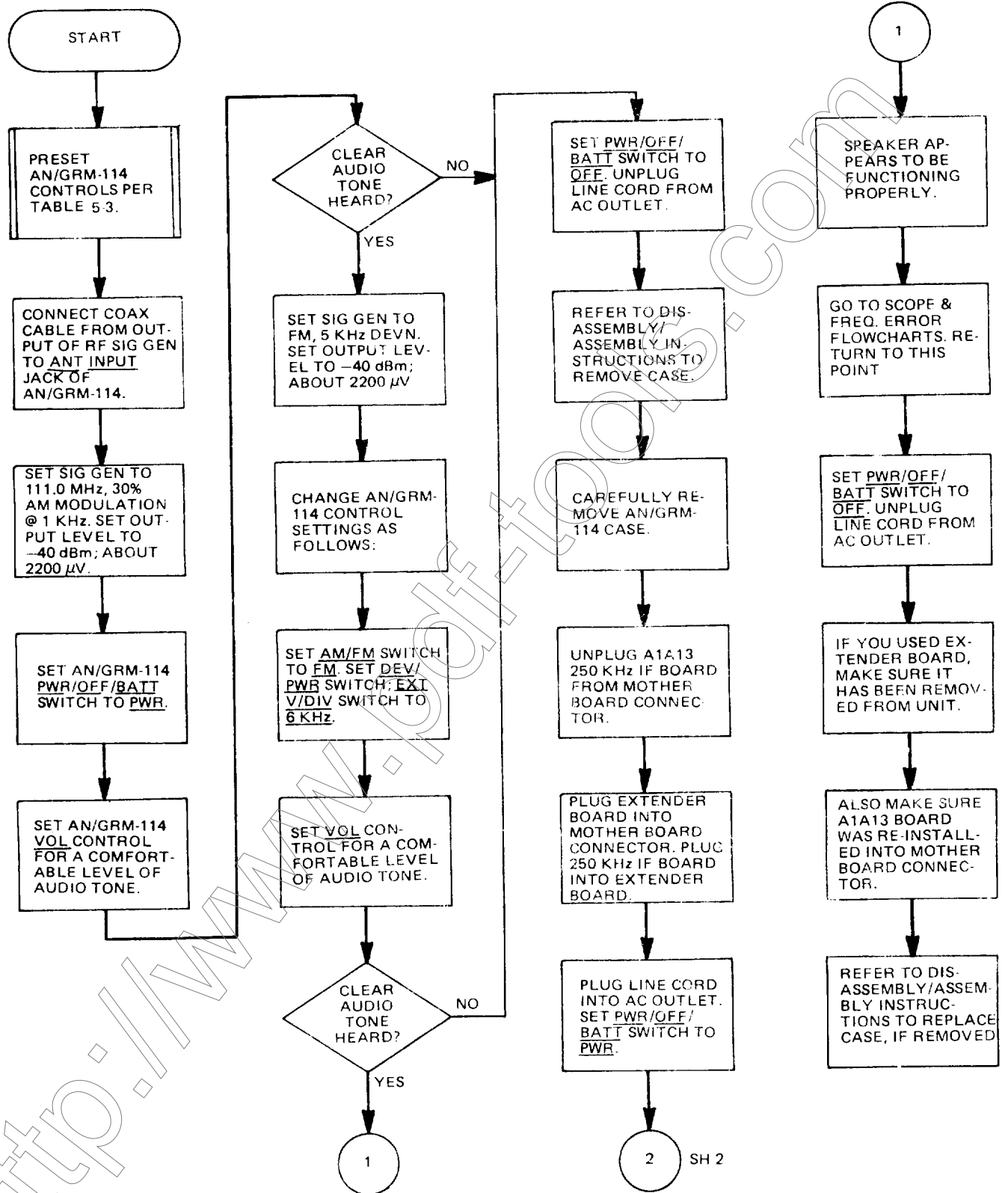


Figure 5-34. Audio frequency monitor troubleshooting (sheet 1 of 4).

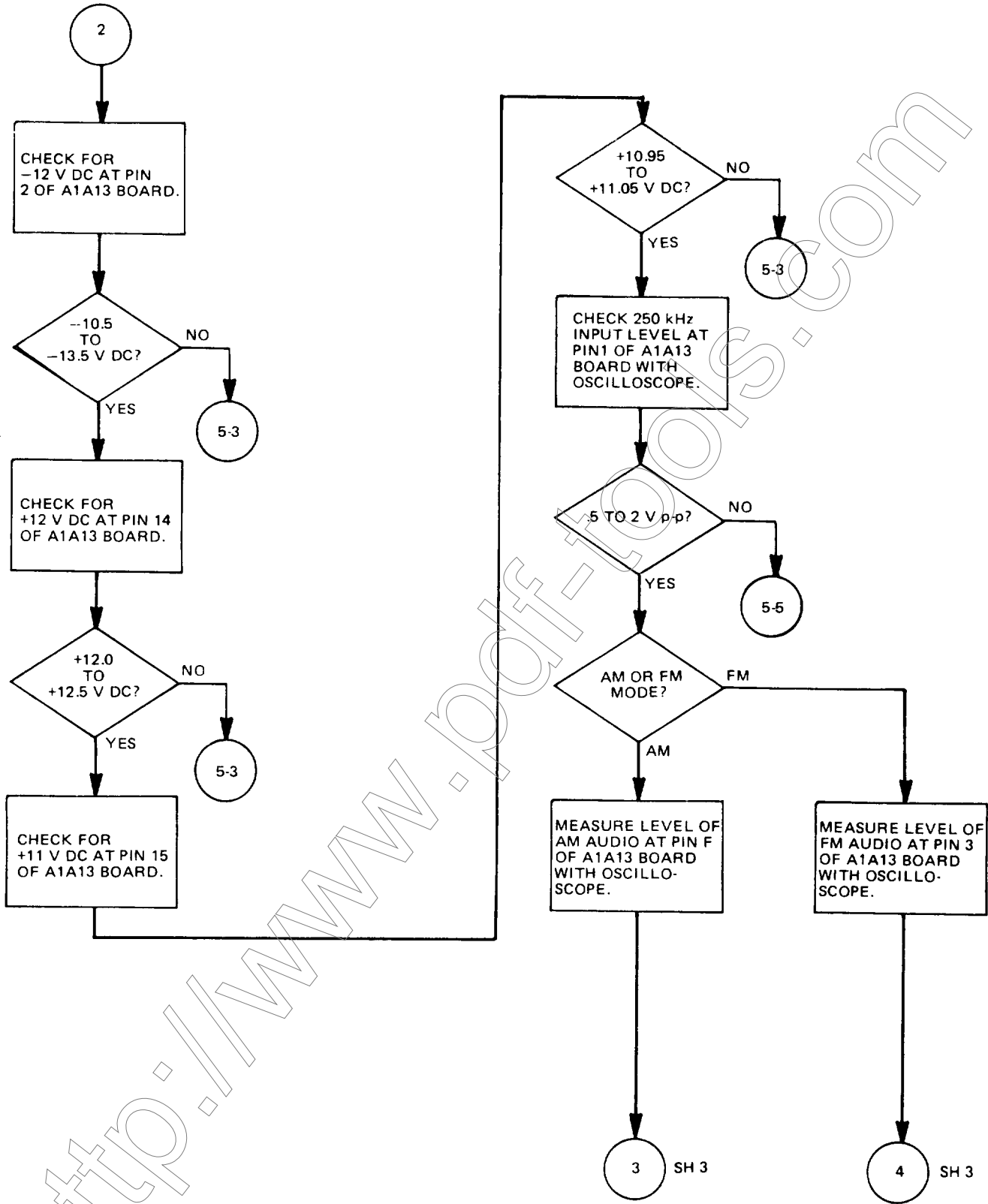


Figure 5-4. Audio frequency monitor troubleshooting (sheet 2 of 4).

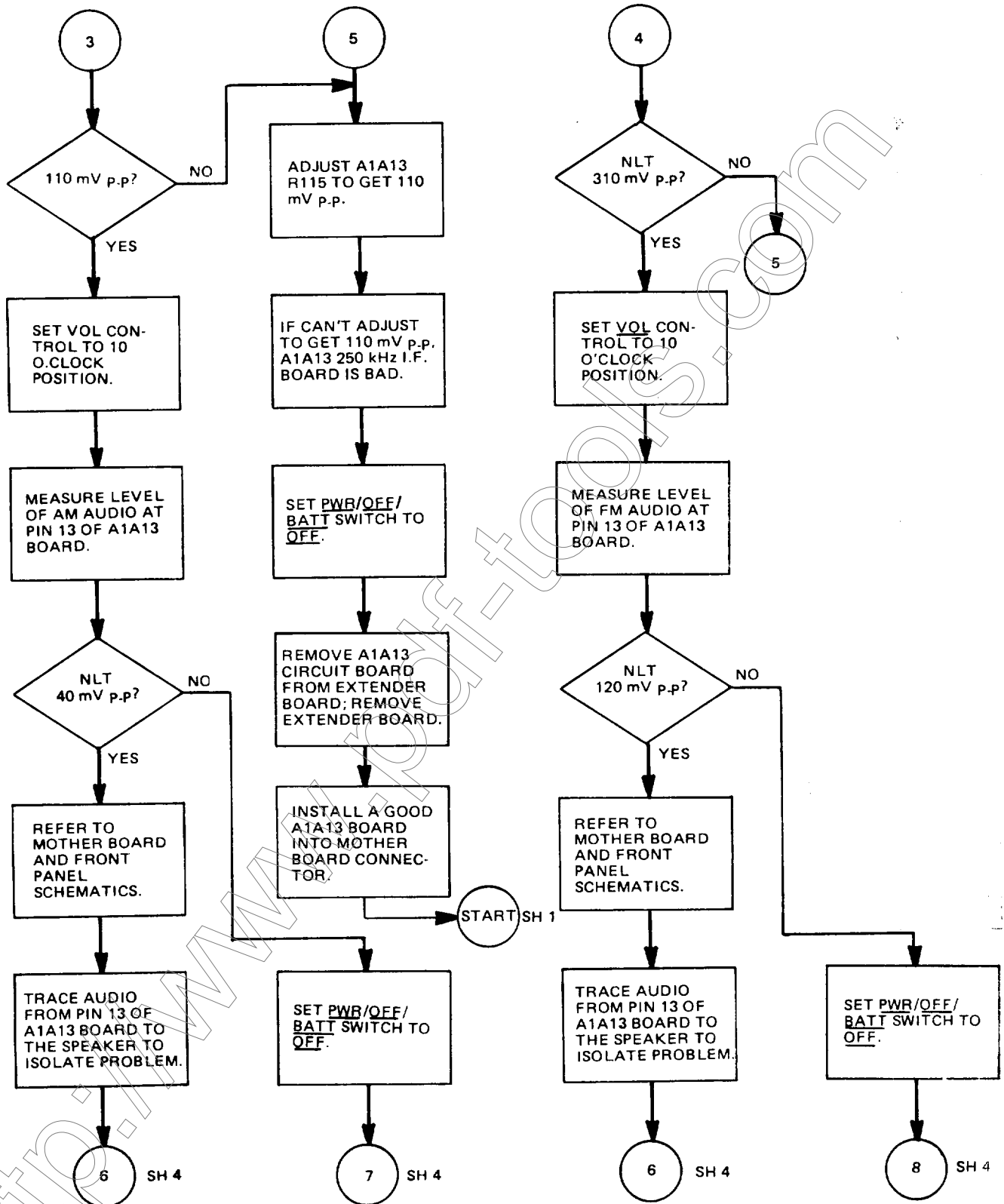


Figure 5-4. Audio frequency monitor troubleshooting (sheet 3 of 4).

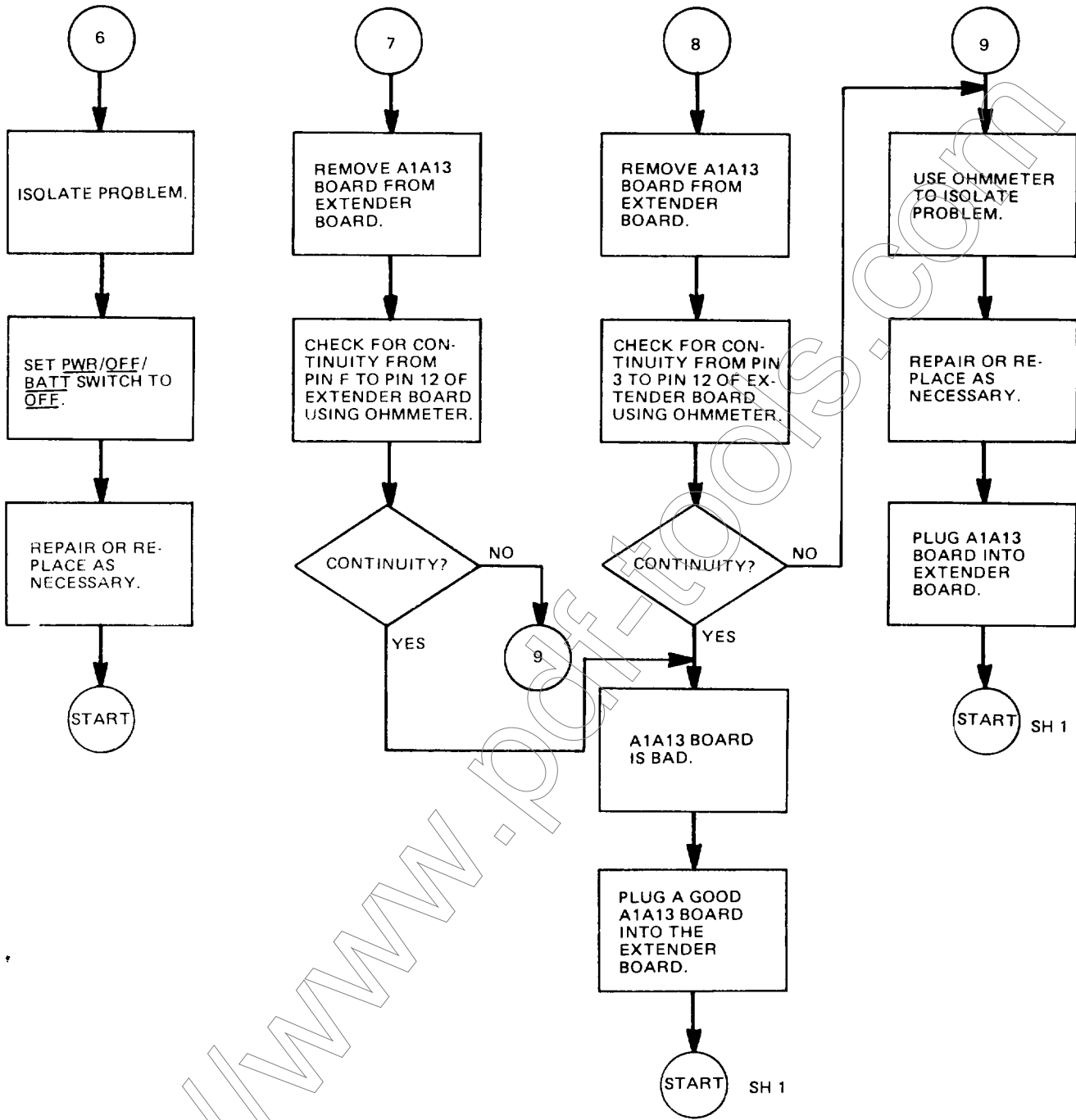


Figure 5-4. Audio frequency monitor troubleshooting (sheet 4 of 4).

Table 5-5. Receiver Troubleshooting - Initial Conditions.

Control	Setting
INTENSITY	As required
EXT V/DIV	15 KHz
EXT V/DIV Vernier	CAL
AC/OFF/DC	DC
SWEEP	1 mS
SWEEP Vernier	CAL
MODULATION FREQ Hz	0000.0
INT MOD/OFF	OFF
VERT	Midrange
ANALY DISPR	OFF
HORIZ	Midrange
1.5/5/15 KHz	15
AM/FM	AM
BFO/OFF	OFF
FREQUENCY MHz	0000000
VOL	Fully ccw
INT MOD/RCVR	RCVR
SQUELCH	Fully ccw
DEV/PWR	SIG
GEN/RCVR	RCVR
RCVR WIDE/MID/NARROW	NARROW
RF LEVEL/BFO INJECTION	10
HI LBL/ $\mu$ V x 100/NORM	NORM
PWR/OFF/BATT	PWR

Table 5-6. 1st and 2nd Local Oscillators (Sheet 1 of 3).

Reading	Meaning										
FL	Frequency of 2ND local oscillator, determined by value of four rightmost thumbwheels of FREQUENCY MHz subtracted from 1080.0000 MHz. $1080.0000 - XXXX = F_L$ .										
$F_v/10$	Frequency delivered to 1080 MHz Multiplier/Mixer.										
$(F_v/10) - 100$ MHz	Frequency produced within 79-80 MHz Loop Circuit Board, delivered to 100 MHz Multiplier/108 MHz Mixer.										
COMB FREQUENCY ( $F_c$ )	<p>LEFTMOST DIGIT OF FREQUENCY MHz THUMBWHEELS</p> <table border="0"> <tr> <td>0 or 1</td> <td>1100 MHz</td> </tr> <tr> <td>2 or 3</td> <td>1300 MHz</td> </tr> <tr> <td>4 or 5</td> <td>1500 MHz</td> </tr> <tr> <td>6 or 7</td> <td>1700 MHz</td> </tr> <tr> <td>8 or 9</td> <td>1900 MHz</td> </tr> </table> <p style="text-align: right;"><math>F_c</math></p>	0 or 1	1100 MHz	2 or 3	1300 MHz	4 or 5	1500 MHz	6 or 7	1700 MHz	8 or 9	1900 MHz
0 or 1	1100 MHz										
2 or 3	1300 MHz										
4 or 5	1500 MHz										
6 or 7	1700 MHz										
8 or 9	1900 MHz										



Table 5-6. 1st and 2nd Local oscillators (Sheet 2 of 3).

Reading	Meaning
$f_{VCO}$	Frequency generated by 1200-2200 MHz Oscillator. It equals 1200 MHz plus the value of the three leftmost digits of the FREQUENCY MHz thumbwheels (in MHz).
$f'_{VCO}$	Frequency generated by 1200-2200 MHz Oscillator as a result of an external voltage control.
$v_{vco}$	DC voltage sent to 1200-2200 MHz Oscillator from the tuning integrator in the V.C.O. Tuner Circuit Board. This voltage controls the frequency of the 1200-2200 MHz Oscillator.
$v''_{VCO}$	DC voltages sent to the 1200-2200 MHz Oscillator by an external dc source.
$F_{vco-Fc}$	Frequency delivered to Heterodyne Amplifier ,2 Prescaler from the High Frequency Multiplier/Mixer.
$f_{vco-Fc}$ 2	Frequency sent to the High Frequency Phase Lock Circuit Board from the Heterodyne Amplifier: ,2 Prescaler.
Spectrum Analyzer Display of High Frequency Multiplier/Mixer Test Point	Refer to the table of Fc values. For the selected frequency the required power level is ---18 dBm to —25 dBm. The unselected frequencies must have power level at least 25 dBm below that of the selected frequency.

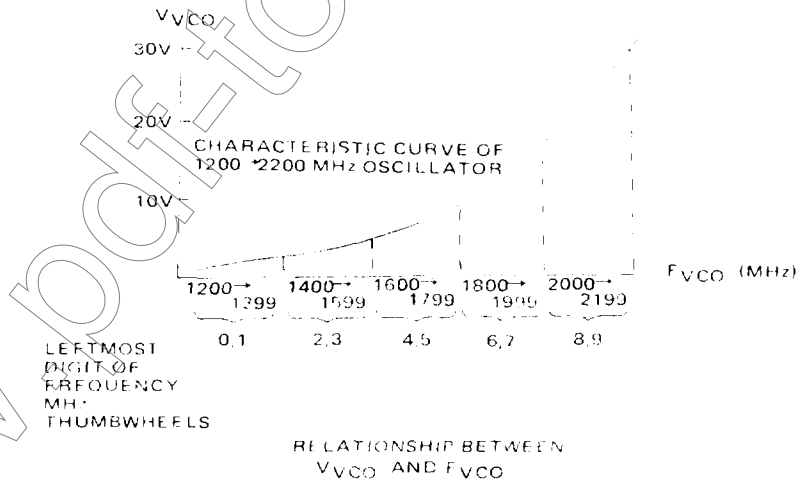
NOTE

The test point is located in the center of the left-hand enclosure end cover of the High Frequency Multiplier Mixer A1A26 (as viewed from the front panel). Insert the High Frequency Multiplier Mixer sniffer (refer to Table 5-1) into the indentation.

Table 5-6. 1st and 2nd Local oscillators (Sheet 3 of 3).

Reading	Meaning					
SWITCHING VOLTAGES FOR $F_c$	V.C.O. Tuner Circuit Board					
		A1A11P-1			A1A26P-4	
		INPUTS			OUTPUT	
	$F_c$	Pin 1	Pin 9	Pin 3	+11V at Pin No.	High Freq. Mult./Mixer +11V at Pin No.
	1100 MHz	0V	0V	0V	10	1
	1300 MHz	0v	0V	+5V	11	2
	1500 MHz	0v	+5V	0V	12	3
1100 MHz	0V	+5V	+5V	13	4	
1900 MHz	58V	0V	0V	11	5	

RELATIONSHIP BETWEEN  $V_{VCO}$  AND  $F_{VCO}$



Operating open-loop, as in troubleshooting, the voltage  $V_{VCO}$  will be one of two possible values for each range. If  $F_{VCO}$  is below  $F_{VCO}$ ,  $V_{VCO}$  will go to the largest negative value of the range in an effort to raise  $F_{VCO}$ . If  $F_{VCO}$  is above  $F_{VCO}$ ,  $V_{VCO}$  will go to the smallest (negative) value for the range.

When the High Frequency Phase-Lock Loop is operating closed loop, as in normal operation, the value of  $V_{VCO}$  will correspond to a particular frequency based on the characteristic curve of the 1200-2200 MHz Oscillator. When  $V_{VCO}$  is monitored (using a "tee" connector), while the leftmost digit of the FREQUENCY MHz thumbwheels is changed, in order through all possible setting,  $V_{VCO}$  should smoothly and continuously increase, in negative voltage, as  $F_{VCO}$  increases.

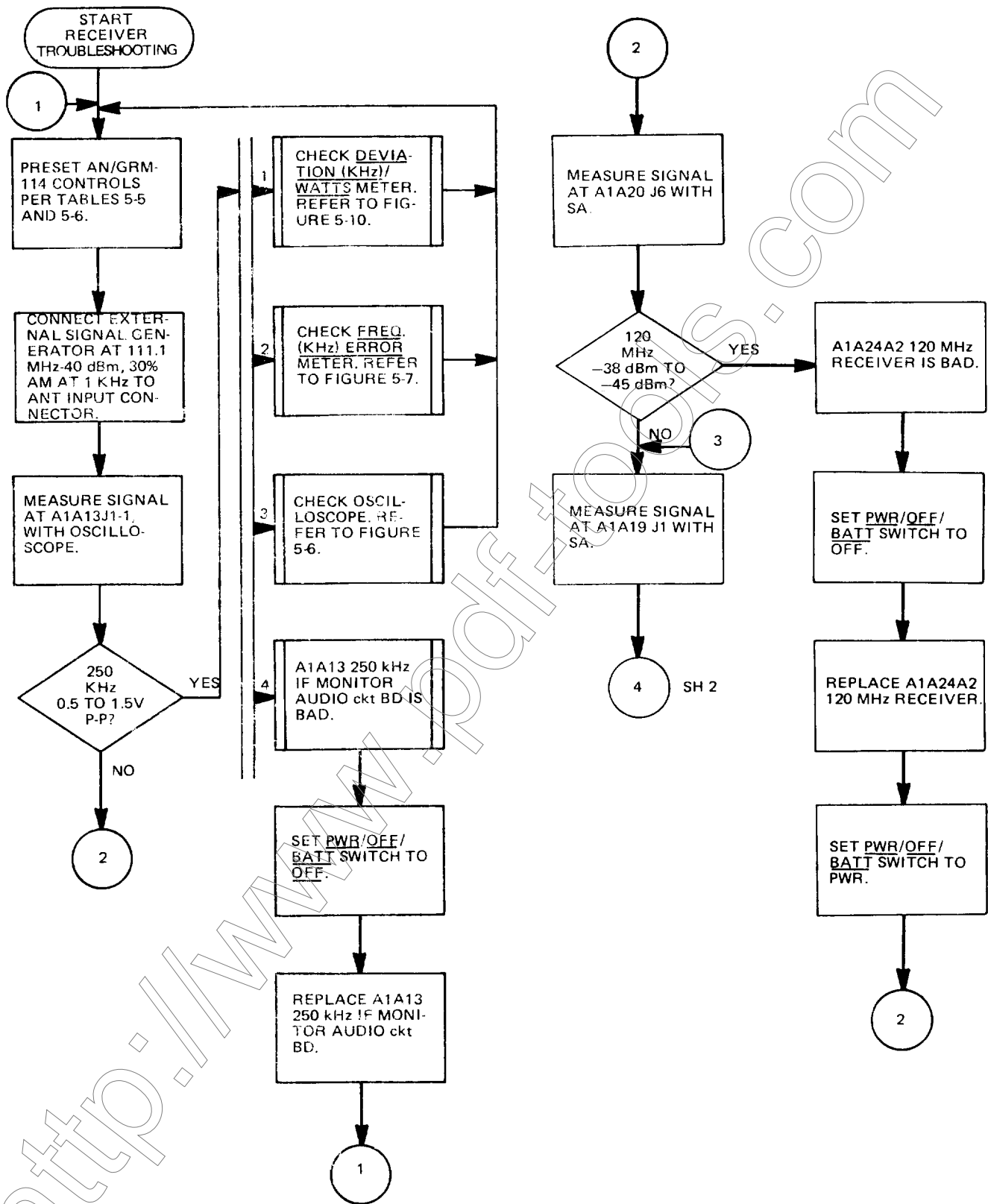


Figure 5-5. Receiver troubleshooting (sheet 1 of 14).

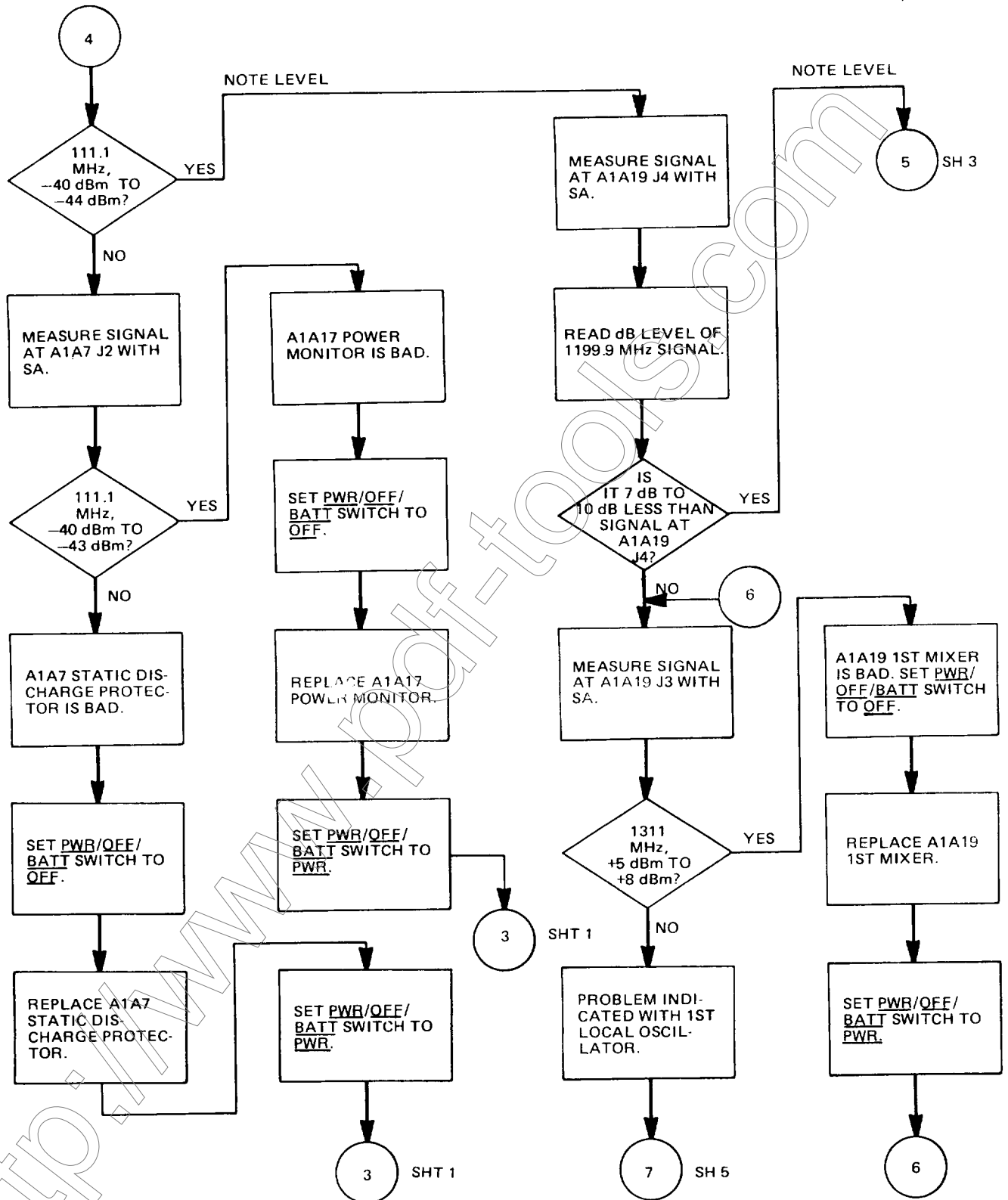


Figure 5-5. Receiver troubleshooting (sheet 2 of 14).

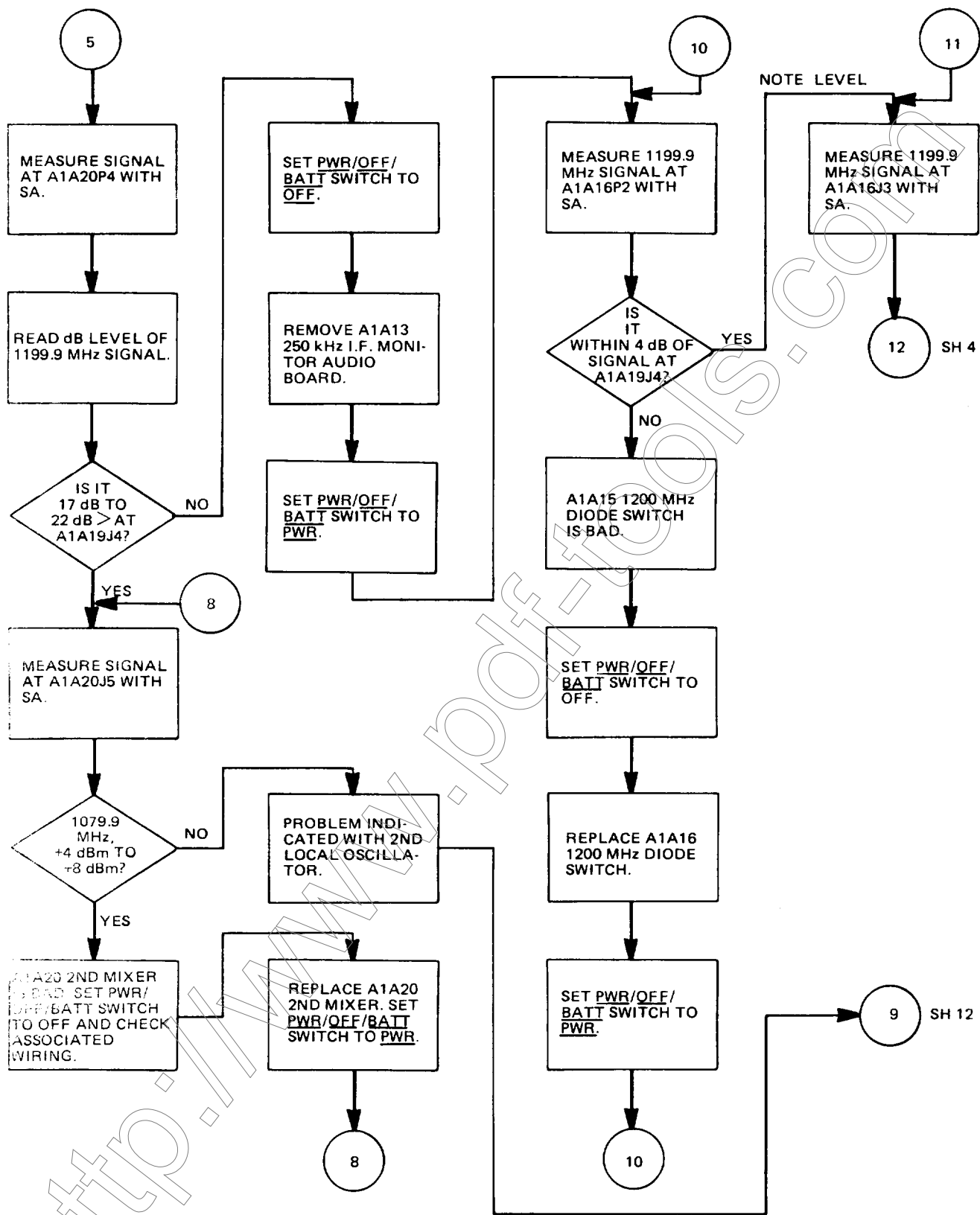


Figure 5-5. Receiver troubleshooting (sheet 3 of 14).

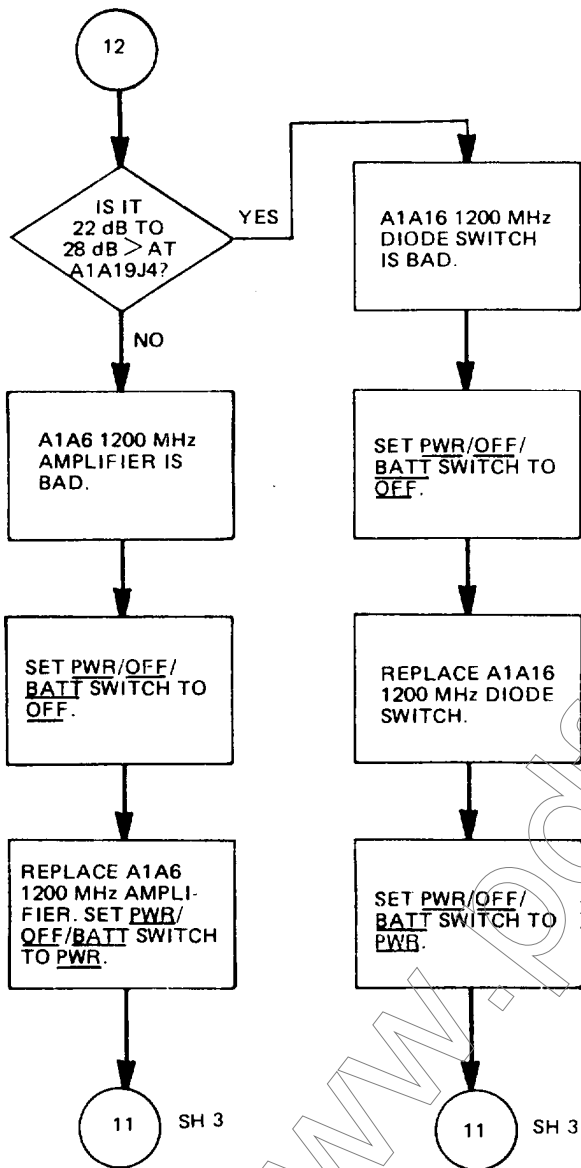


Figure 5-5. Receiver troubleshooting (sheet 4 of 14).

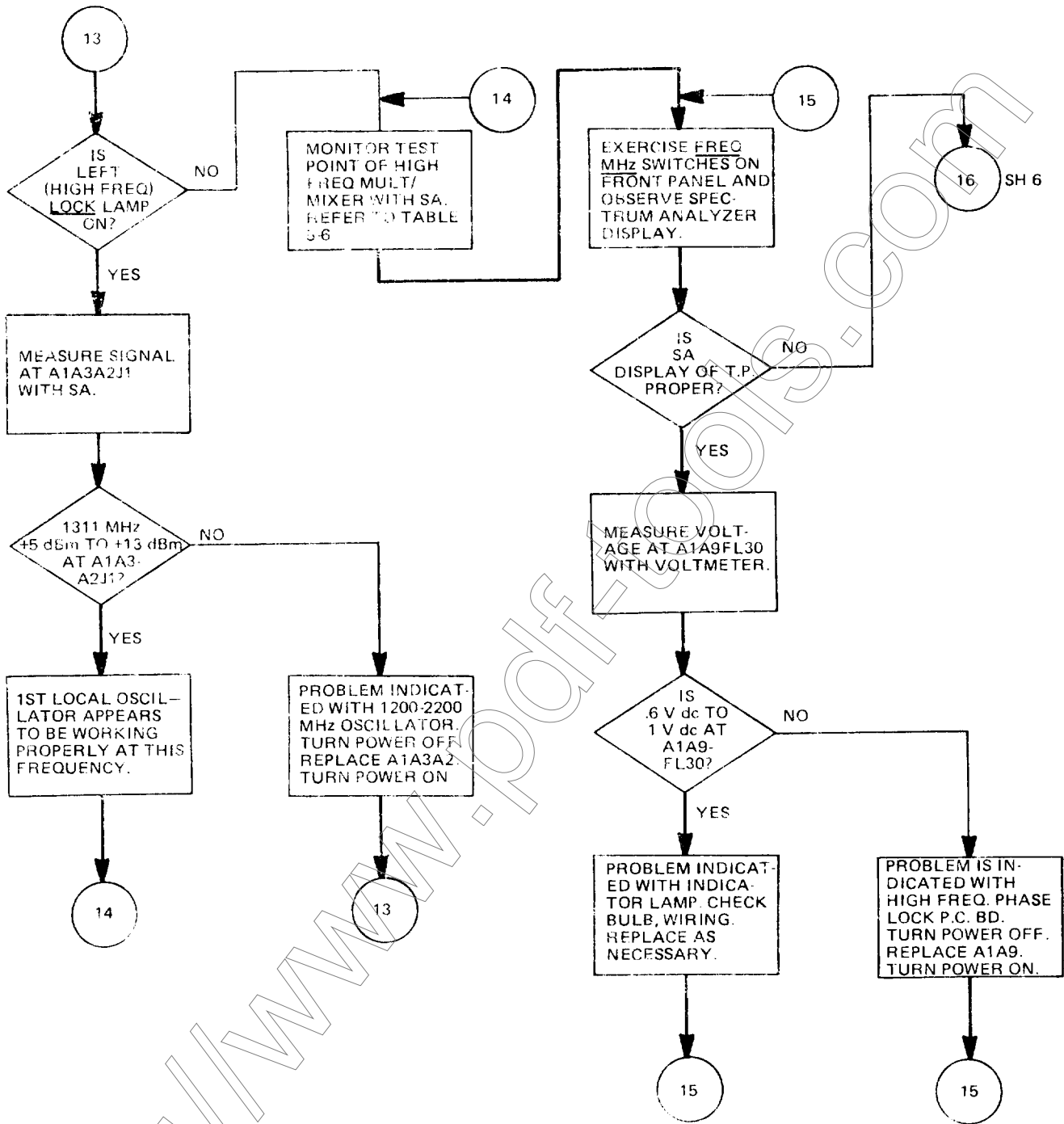


Figure 5-5. Receiver troubleshooting (shet 5 of 14).

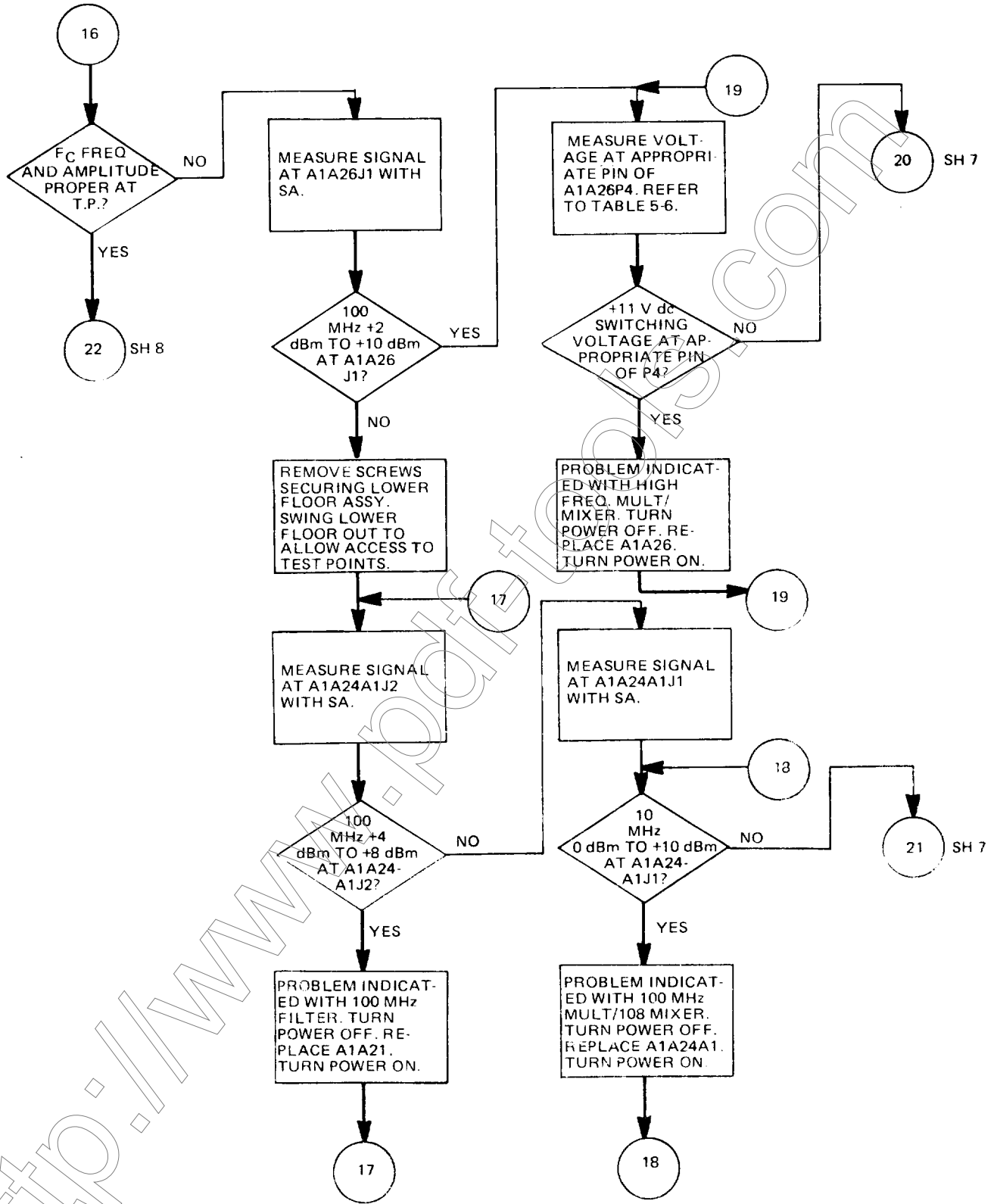


Figure 5-5. Receiver troubleshooting (sheet 6 of 14).



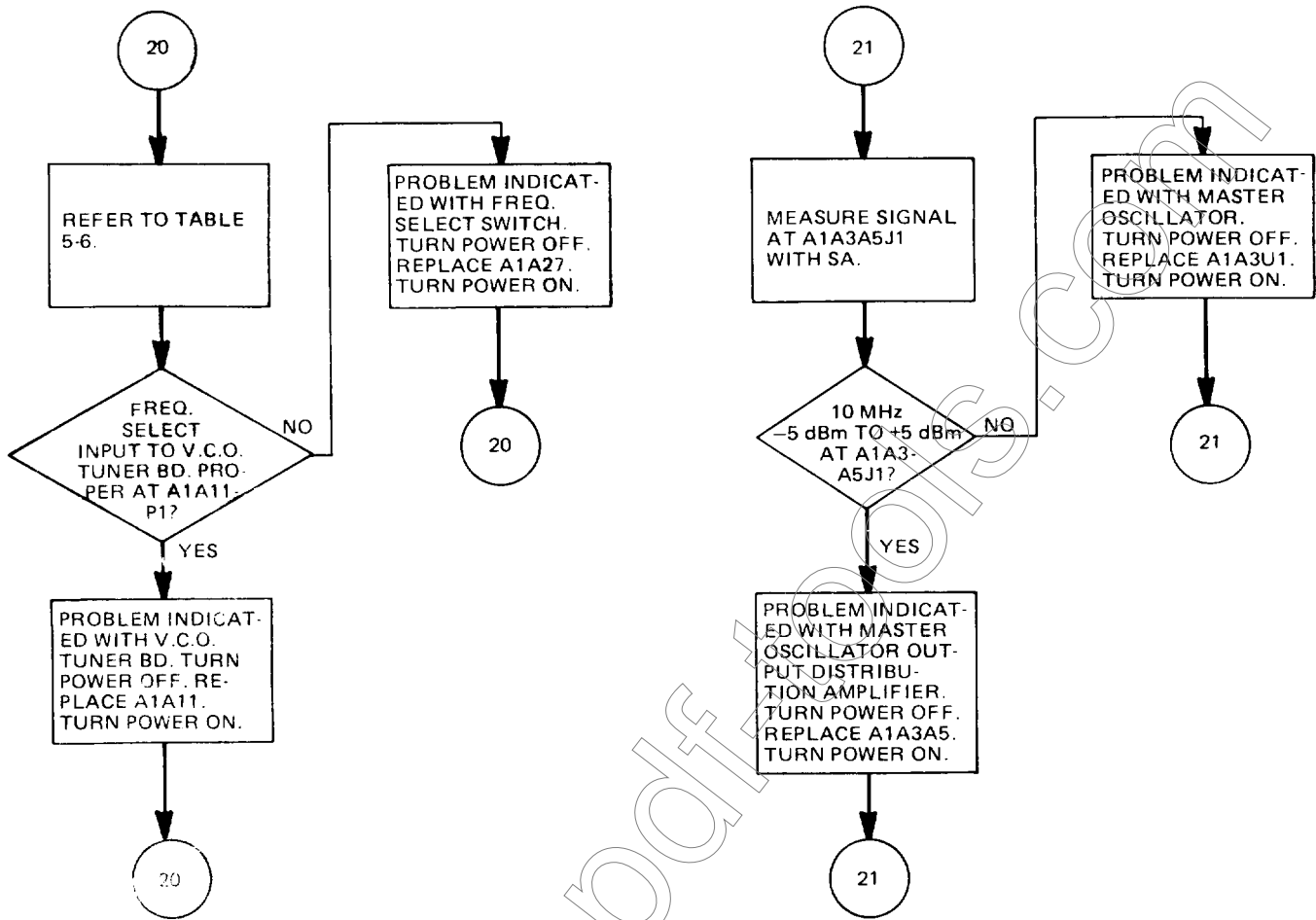


Figure 5-5. Receiver troubleshooting (sheet 7 of 14).

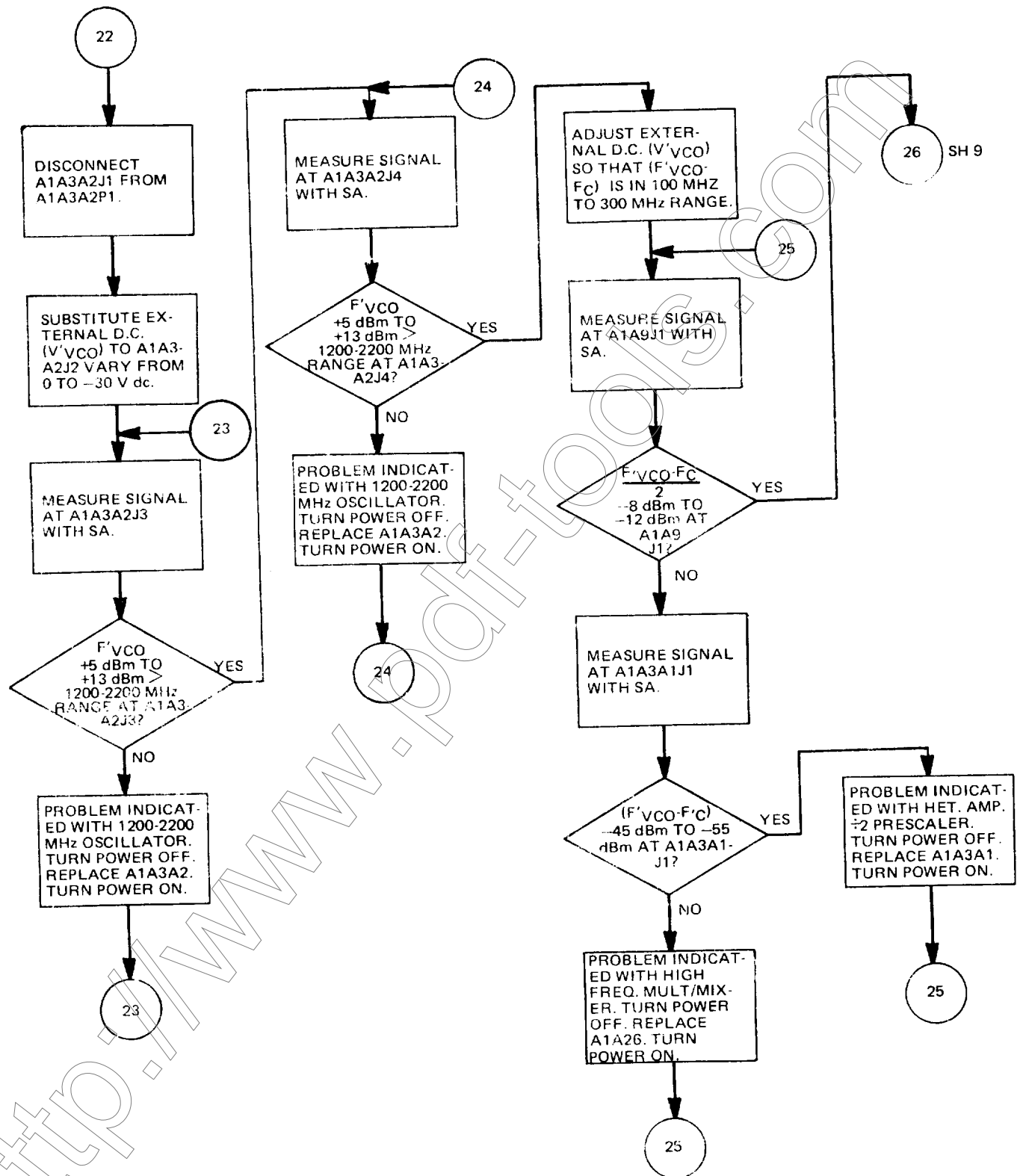


Figure 5-5. Receiver troubleshooting (sheet 8 of 14).

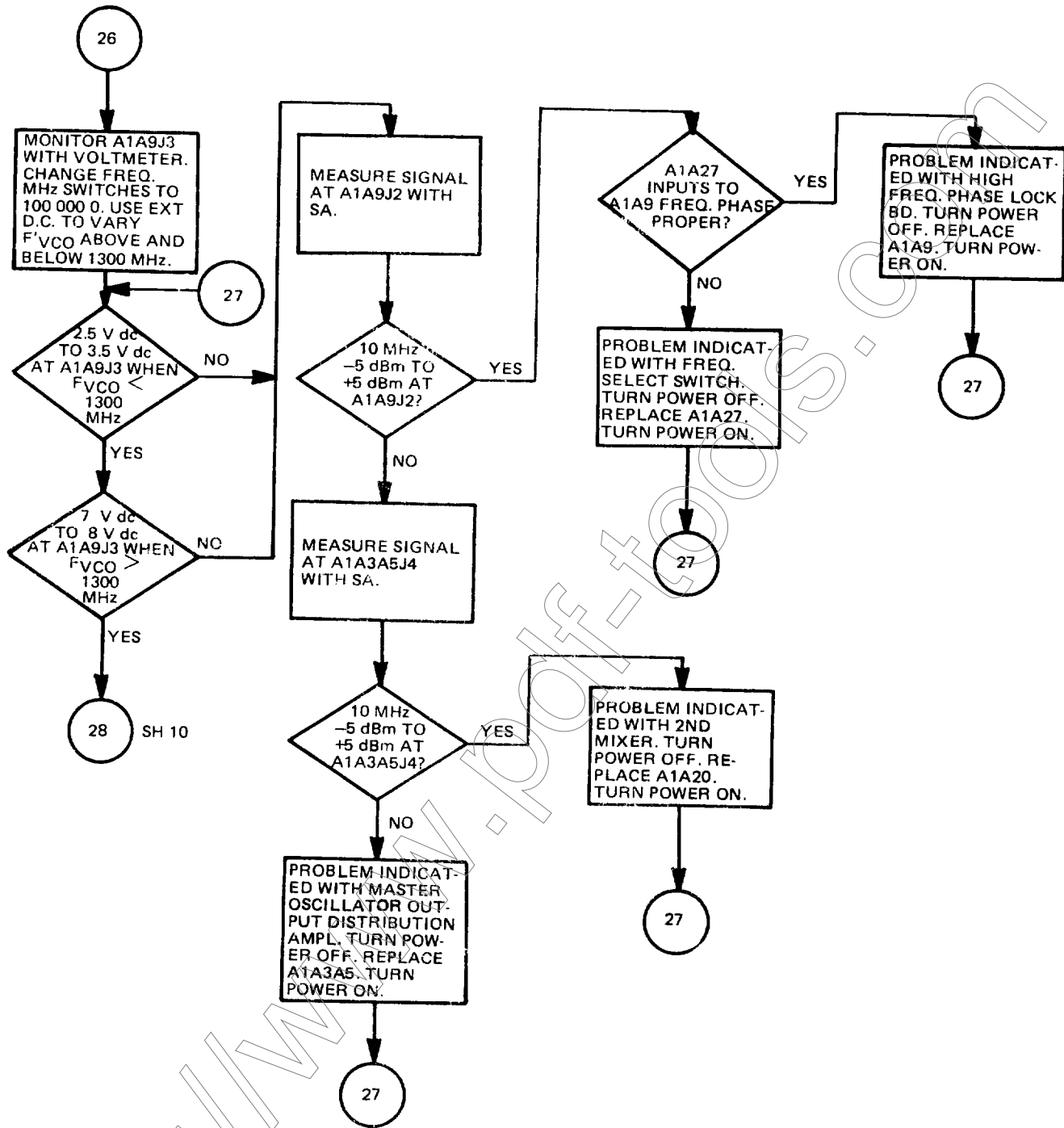


Figure 5-5. Receiver troubleshooting (sheet 9 of 14).

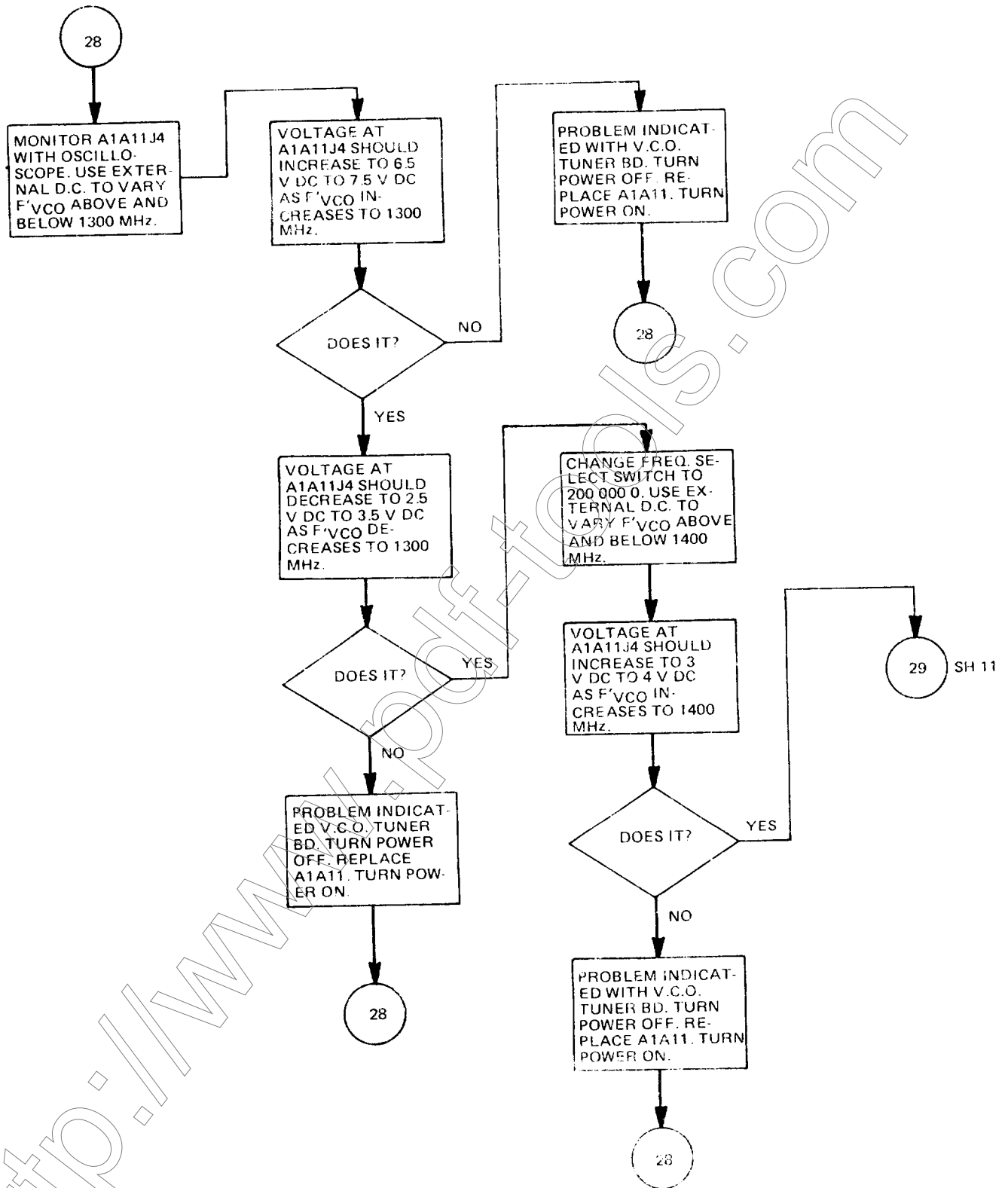


Figure 5-5. Receiver troubleshooting (sheet 10 of 14).

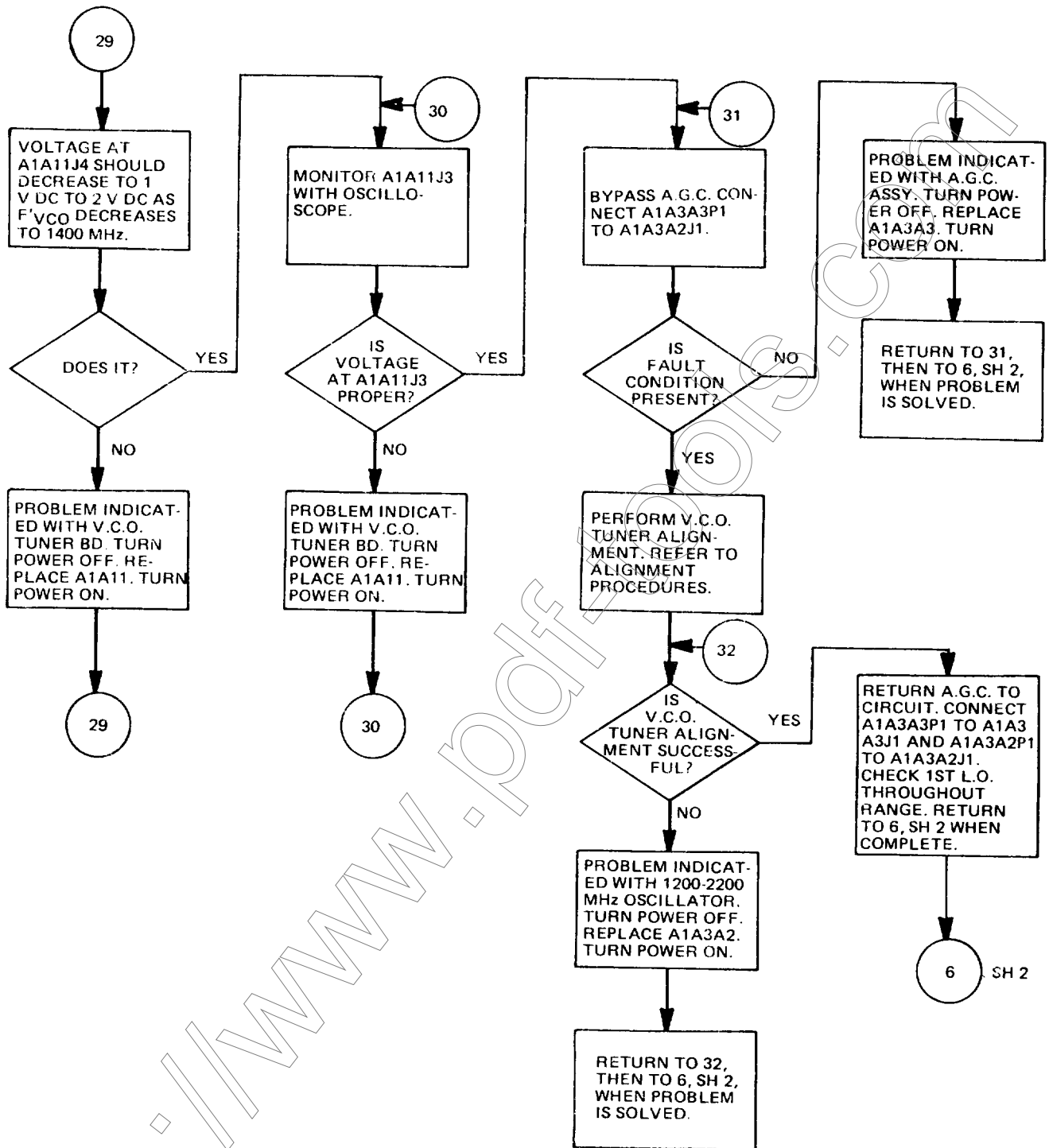


Figure 5-5. Receiver troubleshooting (sheet 11 of 14).

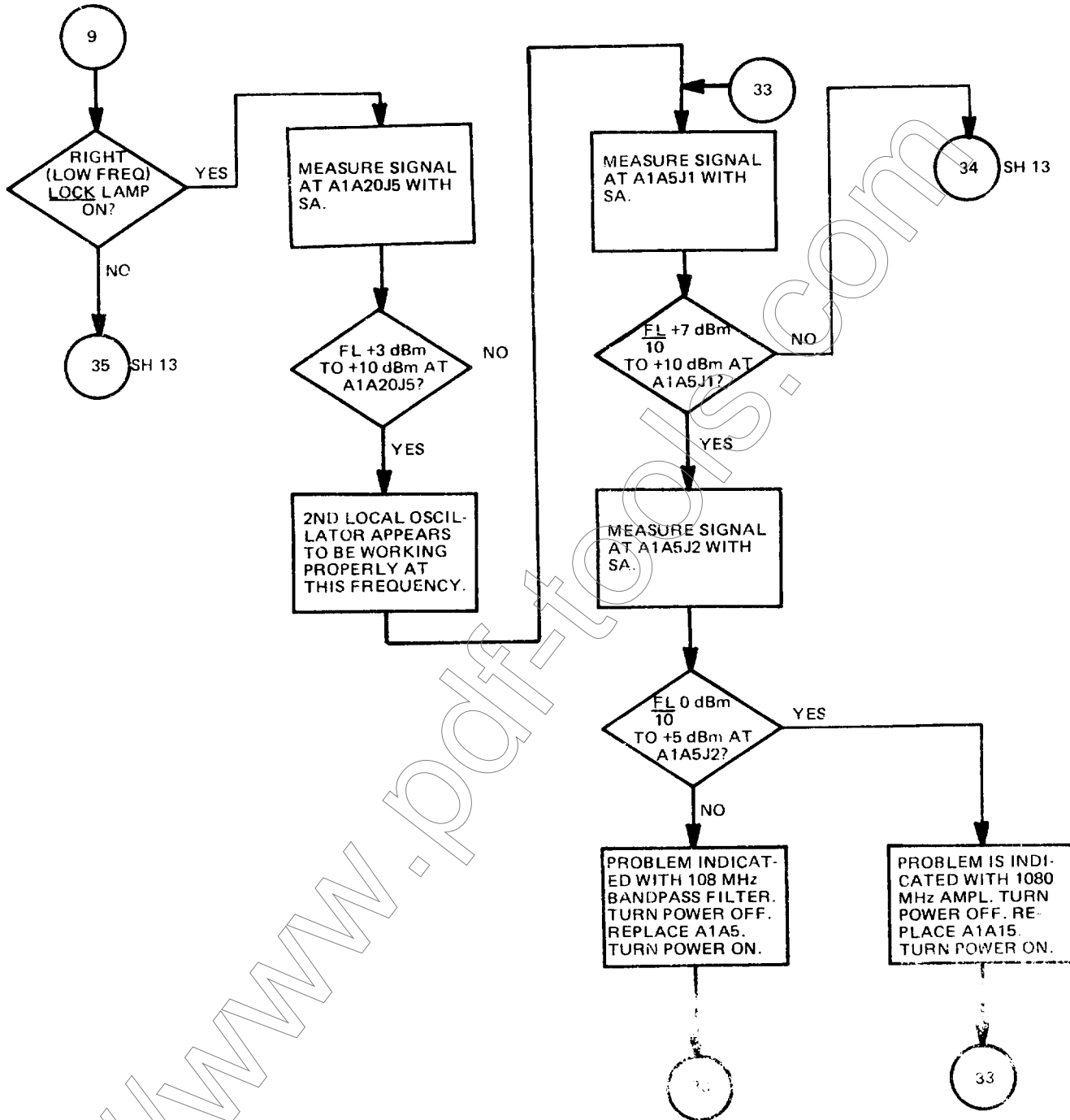


Figure 5-5. Receiver troubleshooting (sheet 12 of 14).

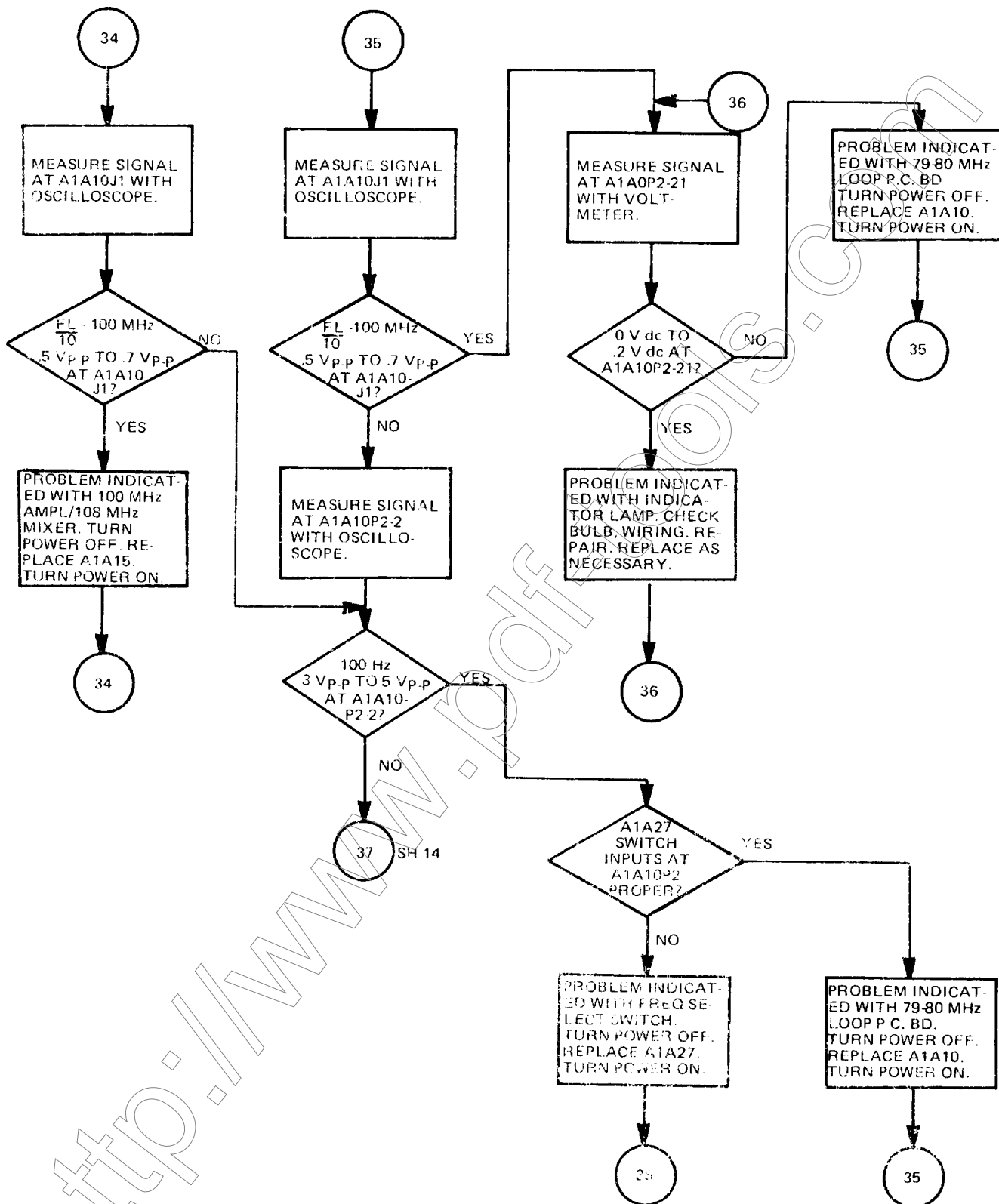


Figure 5-5. Receiver troubleshooting (sheet 13 of 14).

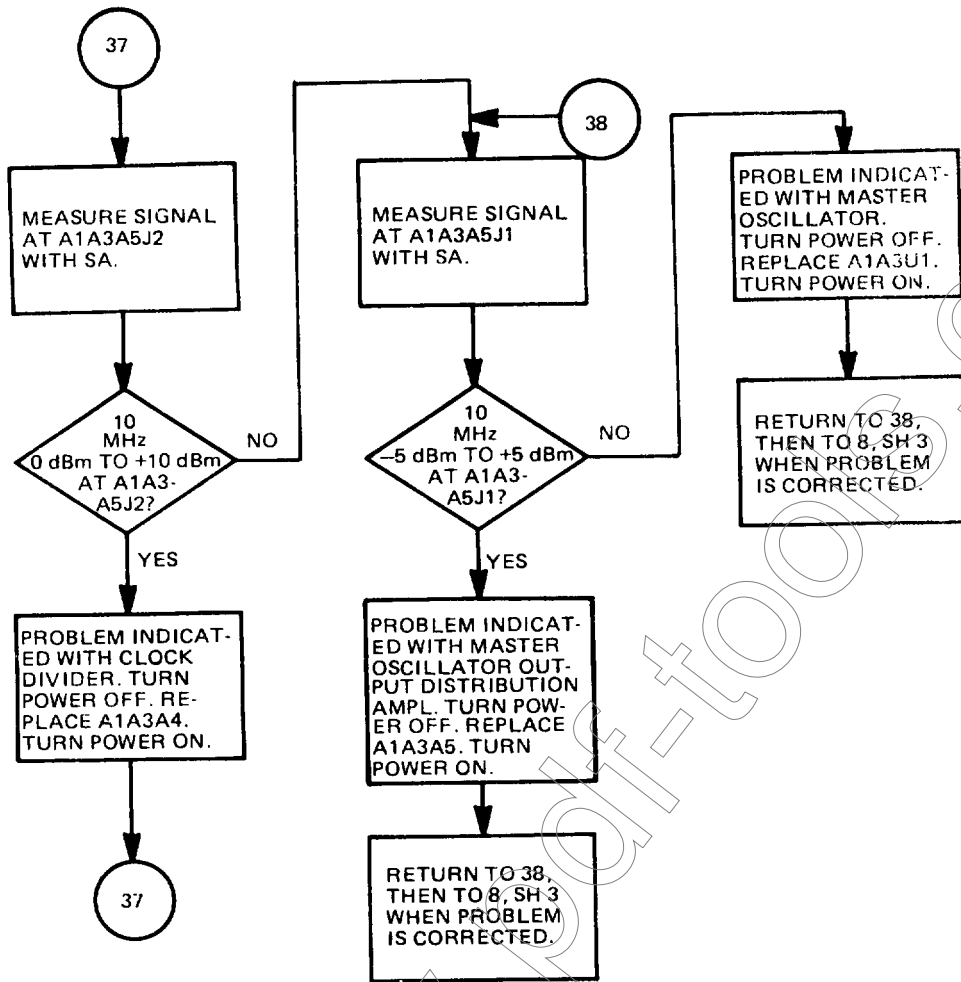


Figure 5-5. Receiver troubleshooting (sheet 14 of 14).



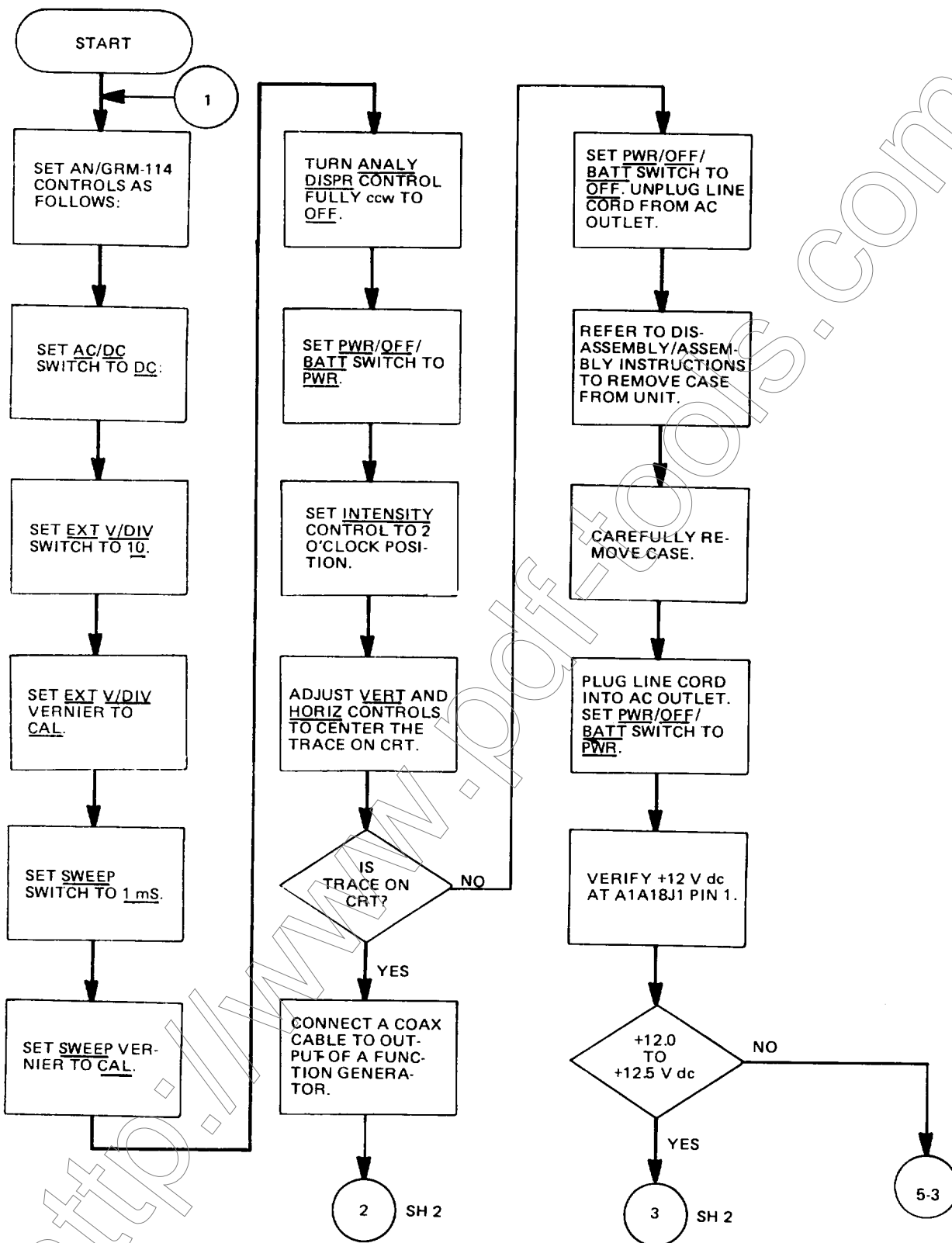


Figure 5-6. Oscilloscope and spectrum analyzer troubleshooting (sheet 1 of 7).

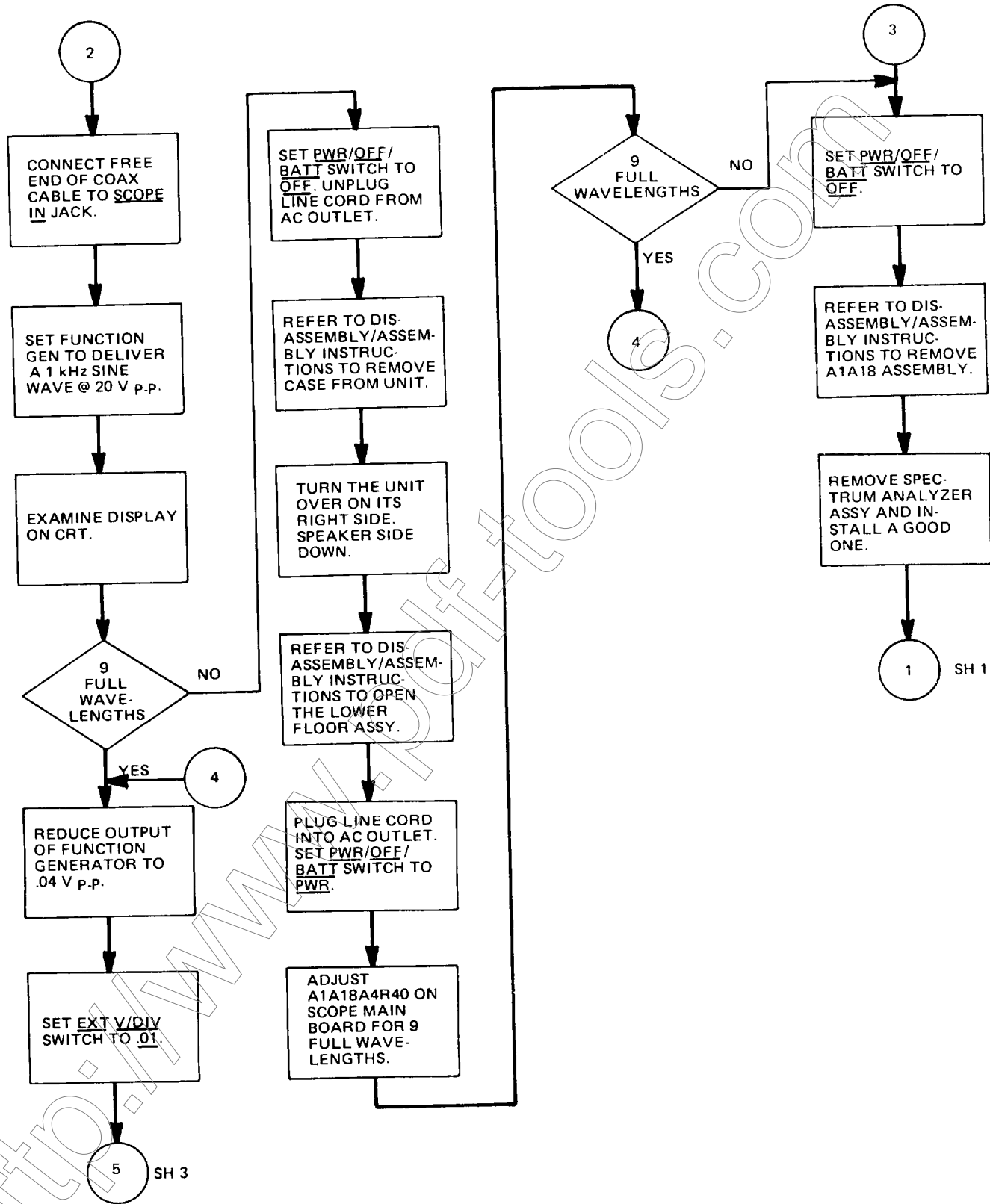


Figure 5-6. Oscilloscope and spectrum analyzer troubleshooting (sheet 2 of 7).

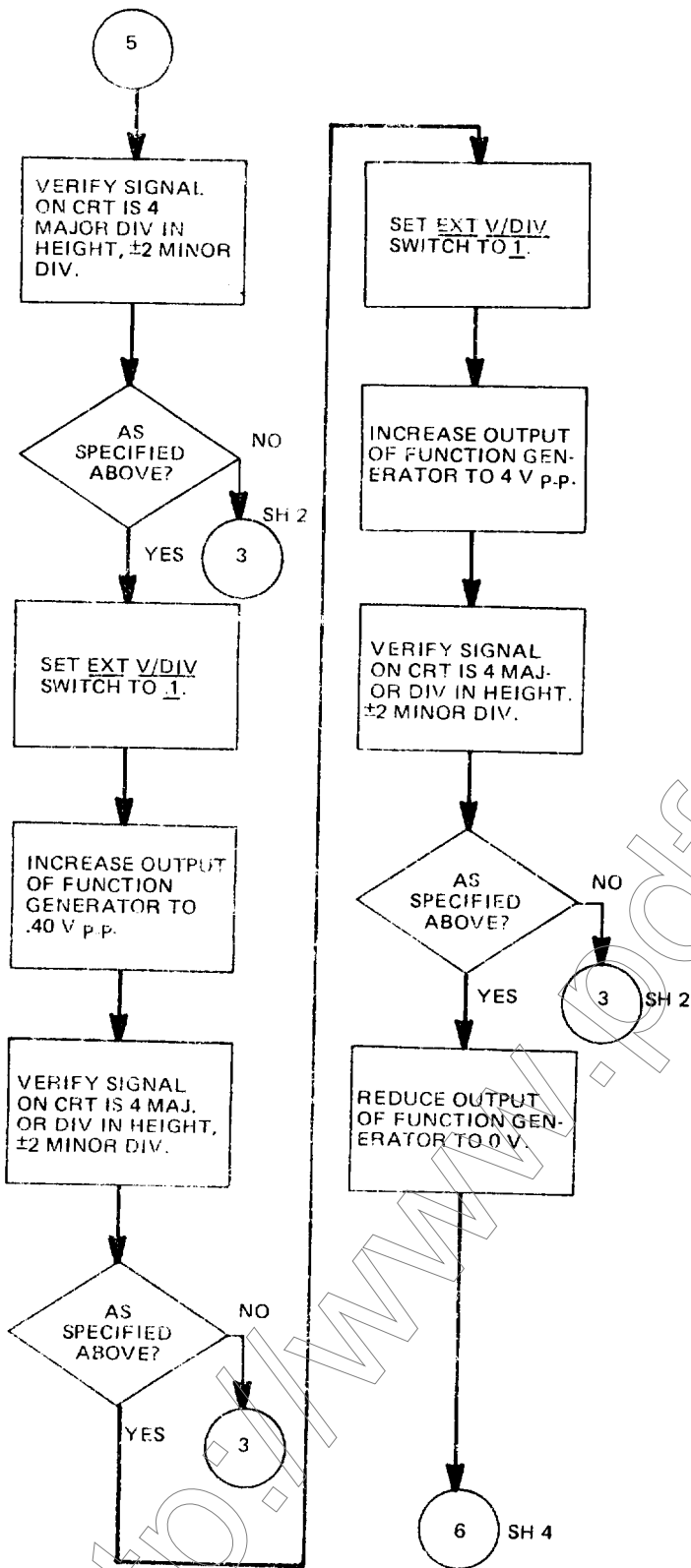


Figure 5-6. Oscilloscope and spectrum analyzer troubleshooting (sheet 3 of 7).

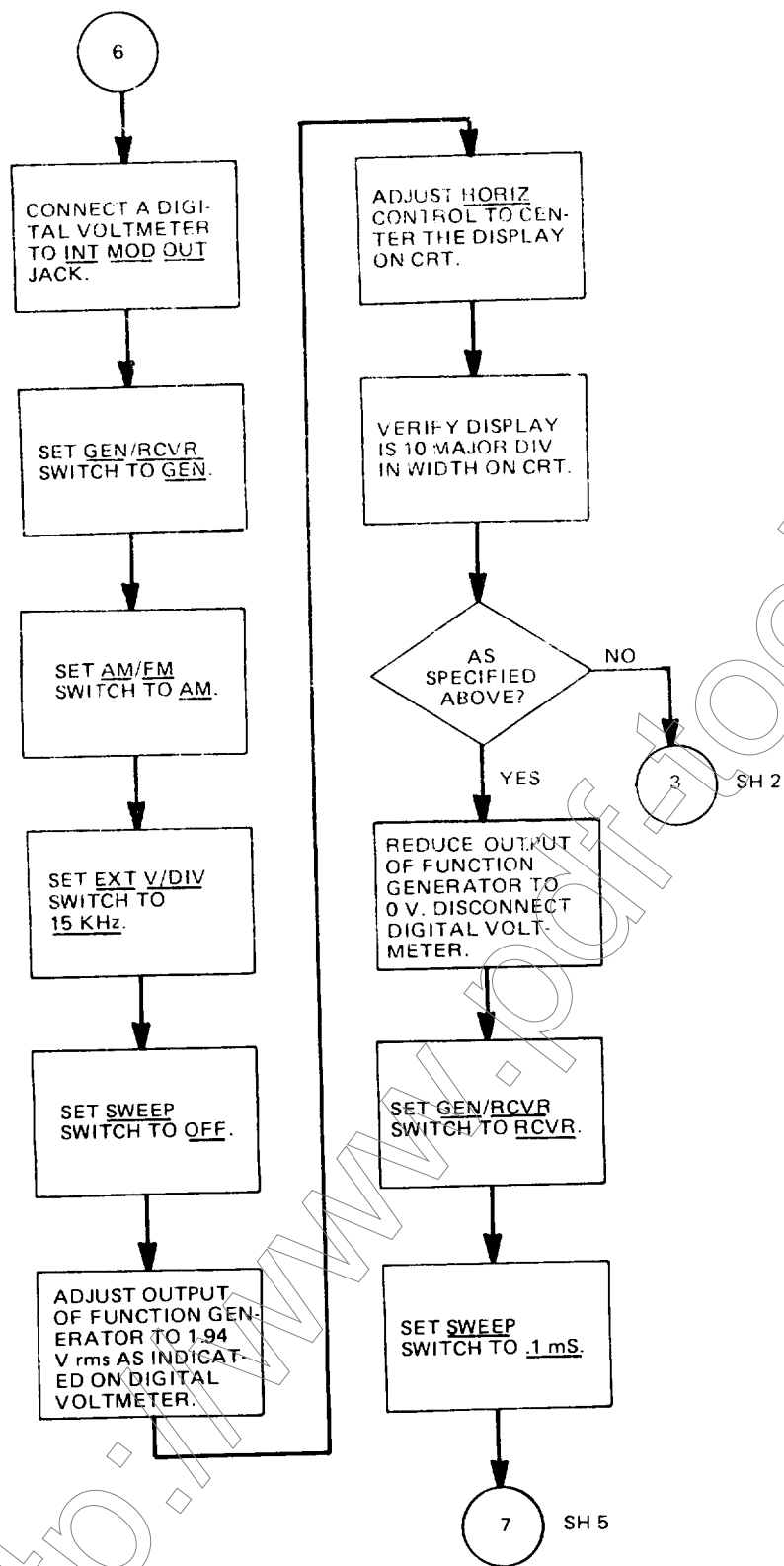


Figure 5-6. Oscilloscope and spectrum analyzer troubleshooting (sheet 4 of 7 ).

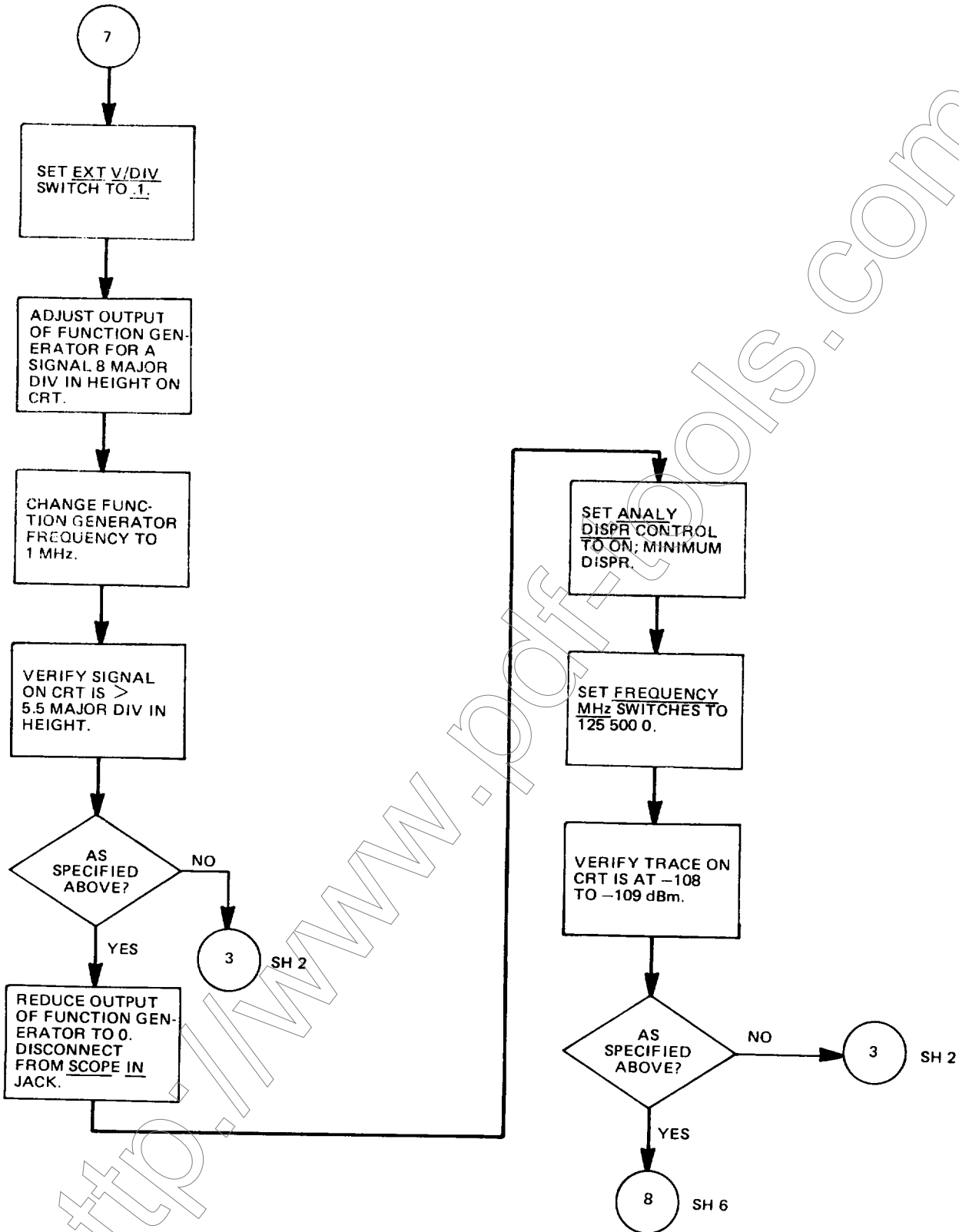


Figure 5-6. Oscilloscope and spectrum analyzer troubleshooting (sheet 5 of 7 ).

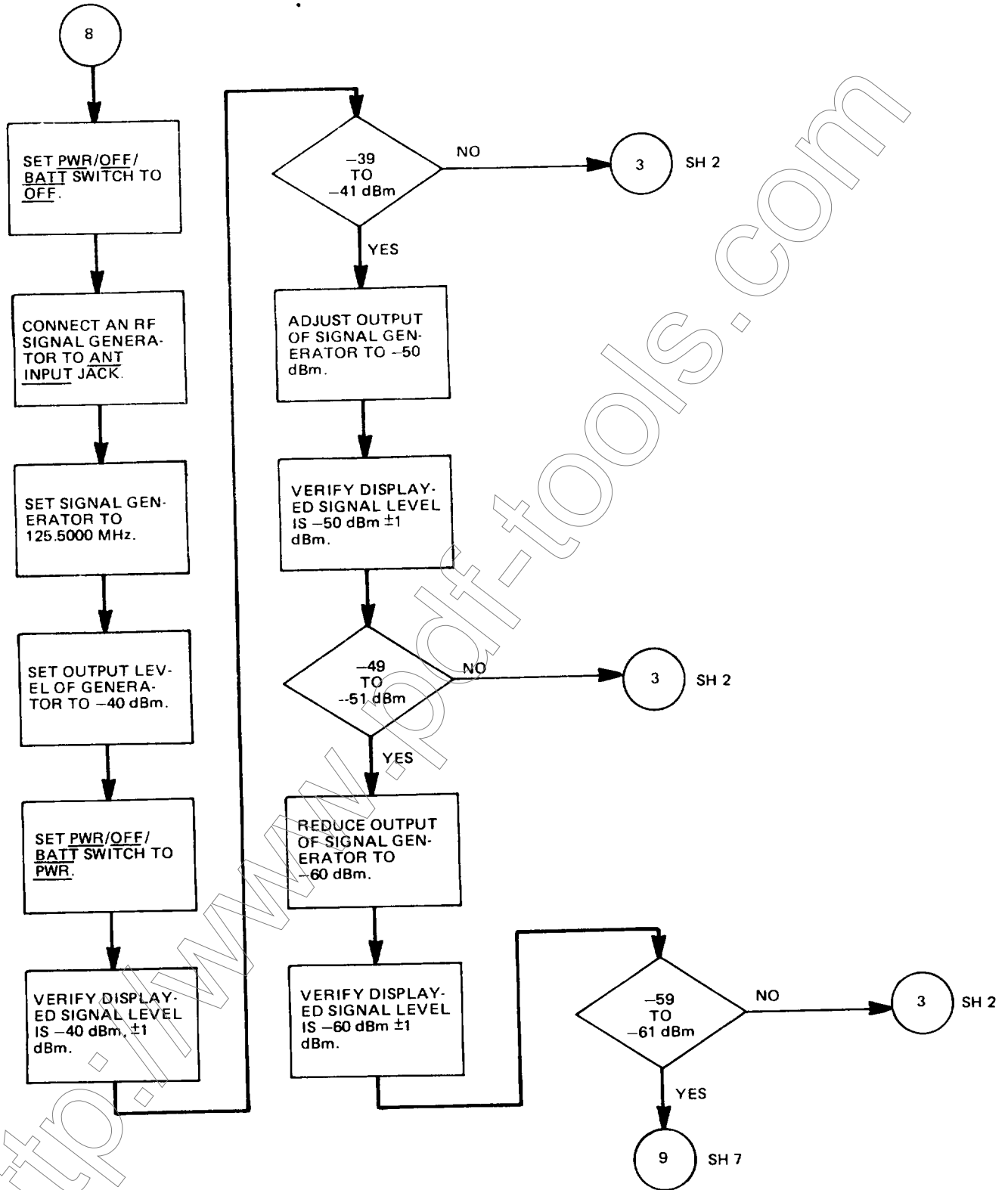


Figure 5-6. Oscilloscope and spectrum analyzer troubleshooting (sheet 6 of 7).

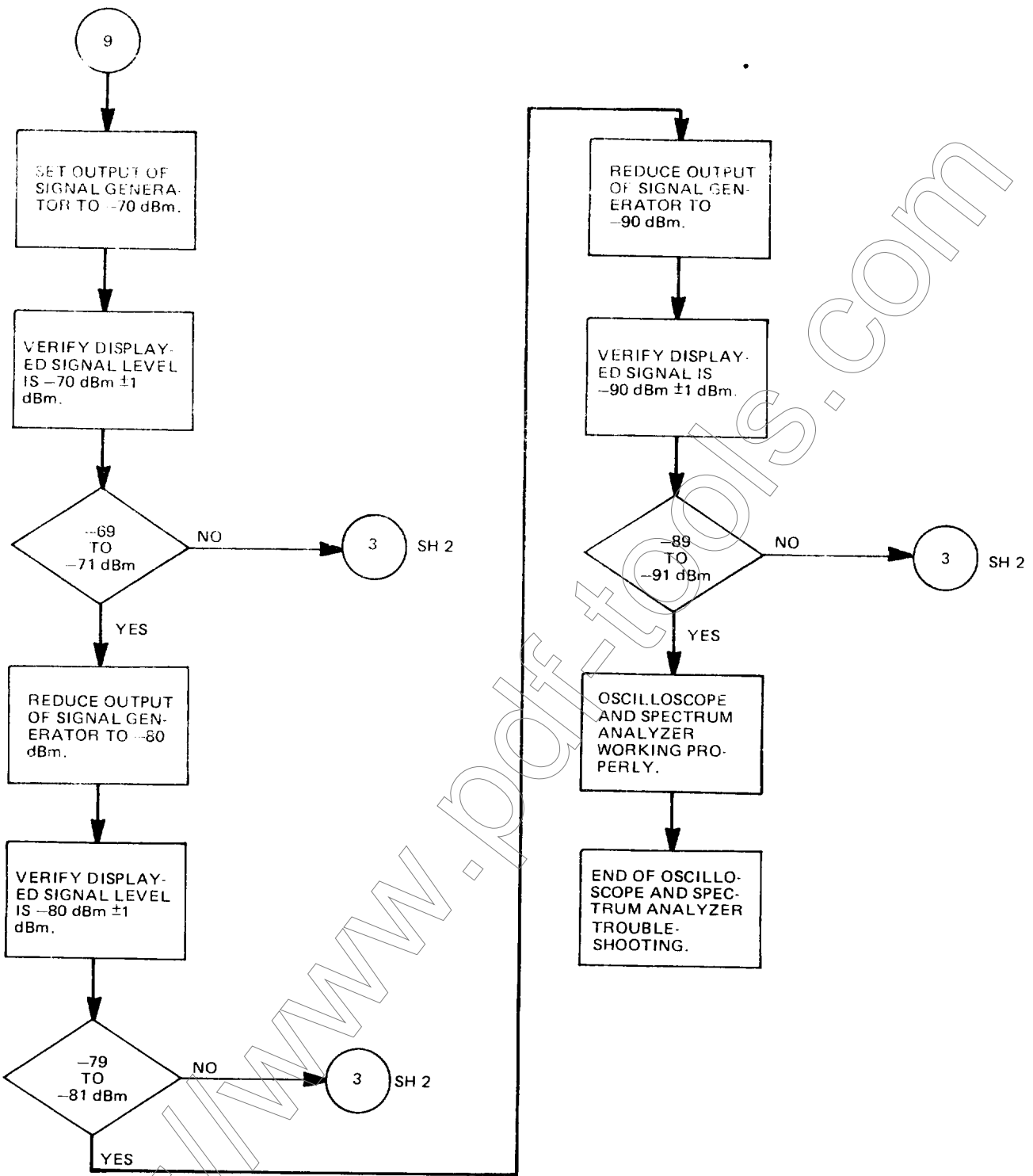


Figure 5-6. Oscilloscope and spectrum analyzer troubleshooting (sheet 7 of 7).

Table 5-7. Frequency Error Measurement - Initial Conditions.

Step	AN/GRM-114 setting
1.	GEN/RCVR switch to RCVR
2.	EXT V/DIV switch to .1
3.	EXT V/DIV vernier to CAL
4.	AC/DC switch to DC
5.	SWEEP switch to 1 mS
6.	SWEEP vernier to CAL
7.	1.5/5/15 KHz switch to 1.5
8.	AM/FM switch to FM
9.	FREQUENCY MHz switches to 0000000
10.	INT MOD/RCVR switch to RCVR
11.	SQUELCH control fully ccw to OFF
12.	RCVR WIDE/MID/NARROW switch to NARROW
13.	AUTO/ZERO, BATT switch to NARROW
14.	PWR/OFF/BATT switch to OFF
15.	Unplug line cord from AC outlet.

Table 5-8. 1st and 2nd Local Oscillators (Sheet 1 of 3).

Reading	Meaning										
$F_L$	Frequency of 2ND local oscillator, determined by value of four rightmost thumbwheels of FREQUENCY MHz subtracted from 1080.0000 MHz. $1080.0000 - XXXX = F_L$ .										
$F_L/10$	Frequency delivered to 1080 MHz Multiplier/Mixer.										
$(F_L/10) - 100$ MHz	Frequency produced within 79-80 MHz Loop Circuit Board, delivered to 100 MHz Multiplier/108 MHz Mixer.										
COMB FREQUENCY ( $F_c$ )	<p>LEFTMOST DIGIT OF FREQUENCY MHz THUMBWHEELS</p> <table border="0"> <tr> <td>0 or 1</td> <td>1100 MHz</td> </tr> <tr> <td>2 or 3</td> <td>1300 MHz</td> </tr> <tr> <td>4 or 5</td> <td>1500 MHz</td> </tr> <tr> <td>6 or 7</td> <td>1700 MHz</td> </tr> <tr> <td>8 or 9</td> <td>1900 MHz</td> </tr> </table>	0 or 1	1100 MHz	2 or 3	1300 MHz	4 or 5	1500 MHz	6 or 7	1700 MHz	8 or 9	1900 MHz
0 or 1	1100 MHz										
2 or 3	1300 MHz										
4 or 5	1500 MHz										
6 or 7	1700 MHz										
8 or 9	1900 MHz										
$F V \square C O$	Frequency generated by 1200-2200 MHz Oscillator. It equals 1200 MHz plus the value of the three leftmost digits of the FREQUENCY MHz thumbwheels (in MHz).										
$F V \square C O$	Frequency generated by 1200-2200 MHz Oscillator as a result of an external voltage control.										



Table 5-8. 1st and 2nd Local Oscillators (Sheet 2 of 3).

Reading	Meaning
$V_{VCO}$	DC voltage sent to 1200-2200 MHz Oscillator from the tuning integrator in the V.C.O. Tuner Circuit Board. This voltage controls the frequency of the 1200-2200 MHz Oscillator.
$V'_{VCO}$	DC voltages sent to the 1200-2200 MHz Oscillator by an external dc source.
$F_{VCO-F_c}$	Frequency delivered to Heterodyne Amplifier, 2 Prescaler from the High Frequency Multiplier/Mixer.
$F_{VCO-F_c}$	Frequency sent to the High Frequency Phase Lock Circuit Board from the Heterodyne Amplifier, 2 Prescaler.
Spectrum Analyzer Display of High Frequency Multiplier/Mixer Test Point	Refer to the table of $F_c$ values. For the selected frequency the required power level is -18 dBm to -25 dBm. The unselected frequencies must have power level at least 25 dBm below that of the selected frequency.

NOTE

The test point is located in the center of the left-hand enclosure end cover of the High Frequency Multiplier Mixer A1A26 (as viewed from the front panel). Insert the High Frequency Multiplier Mixer sniffer (refer to Table 5-1) into the indentation.

SWITCHING VOLTAGES FOR  $F_c$

		V.C.O. Tuner Circuit Board				
		A1A11P-1			A1A261P-4	
		INPUTS			OUTPUTS	High Freq. Mult./Mixer
$F_c$		Pin 2	Pin 2	Pin 3	+11V at Pin No.	+11V at Pin No.
1100	MHz	0V	0V	0V	10	1
1300	MHz	0V	0V	+5V	11	2
1500	MHz	0V	+5V	0V	12	3
1100	MHz	0V	+5V	+5V	13	4
1900	MHz	+5V	0V	0V	14	5

Table 5-8. 1st and 2nd Local Oscillators (Sheet 3 of 3).

Reading	Meaning
<p>RELATIONSHIP BETWEEN <math>V_{VCO}</math> AND <math>F_{VCO}</math></p>	<div style="text-align: center;"> <p>CHARACTERISTIC CURVE OF 1200-2200 MHz OSCILLATOR</p> <p>LEFTMOST DIGIT OF FREQUENCY MHz THUMBWHEELS</p> <p>RELATIONSHIP BETWEEN <math>V_{VCO}</math> AND <math>F_{VCO}</math></p> </div> <p>Operating open-loop, as in troubleshooting, the voltage <math>V_{VCO}</math> will be one of two possible values for each range. If <math>F_{VCO}</math> is below <math>F_{VCO}</math>, <math>V_{VCO}</math> will go to the largest negative value of the range in an effort to raise <math>F_{VCO}</math>. If <math>F_{VCO}</math> is above <math>F_{VCO}</math>, <math>V_{VCO}</math> will go to the smallest (negative) value for the range.</p> <p>When the High Frequency Phase-Lock Loop is operating closed loop, as in normal operation, the value of <math>V_{VCO}</math> will correspond to a particular frequency based on the characteristic curve of the 1200-2200 MHz Oscillator. When <math>V_{VCO}</math> is monitored (using a "tee" connector), while the leftmost digit of the FREQUENCY MHz thumbwheels is changed, in order through all possible settings, <math>V_{VCO}</math> should smoothly and continuously increase, in negative voltage, as <math>F_{VCO}</math> increases.</p>

http://www.EngineeringBooksPdf.com

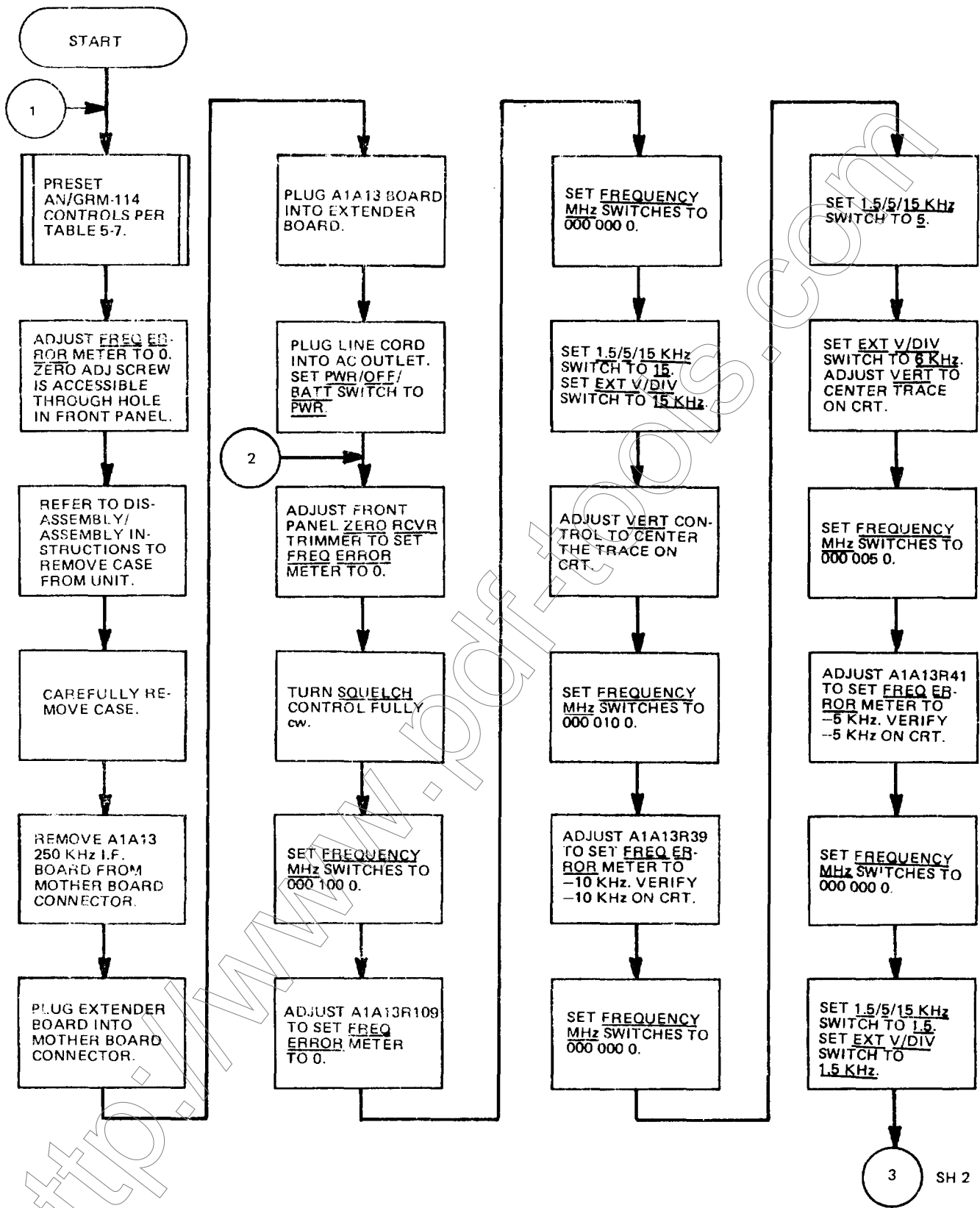


Figure 5-7. Frequency error measurement troubleshooting (sheet 1 of 3).

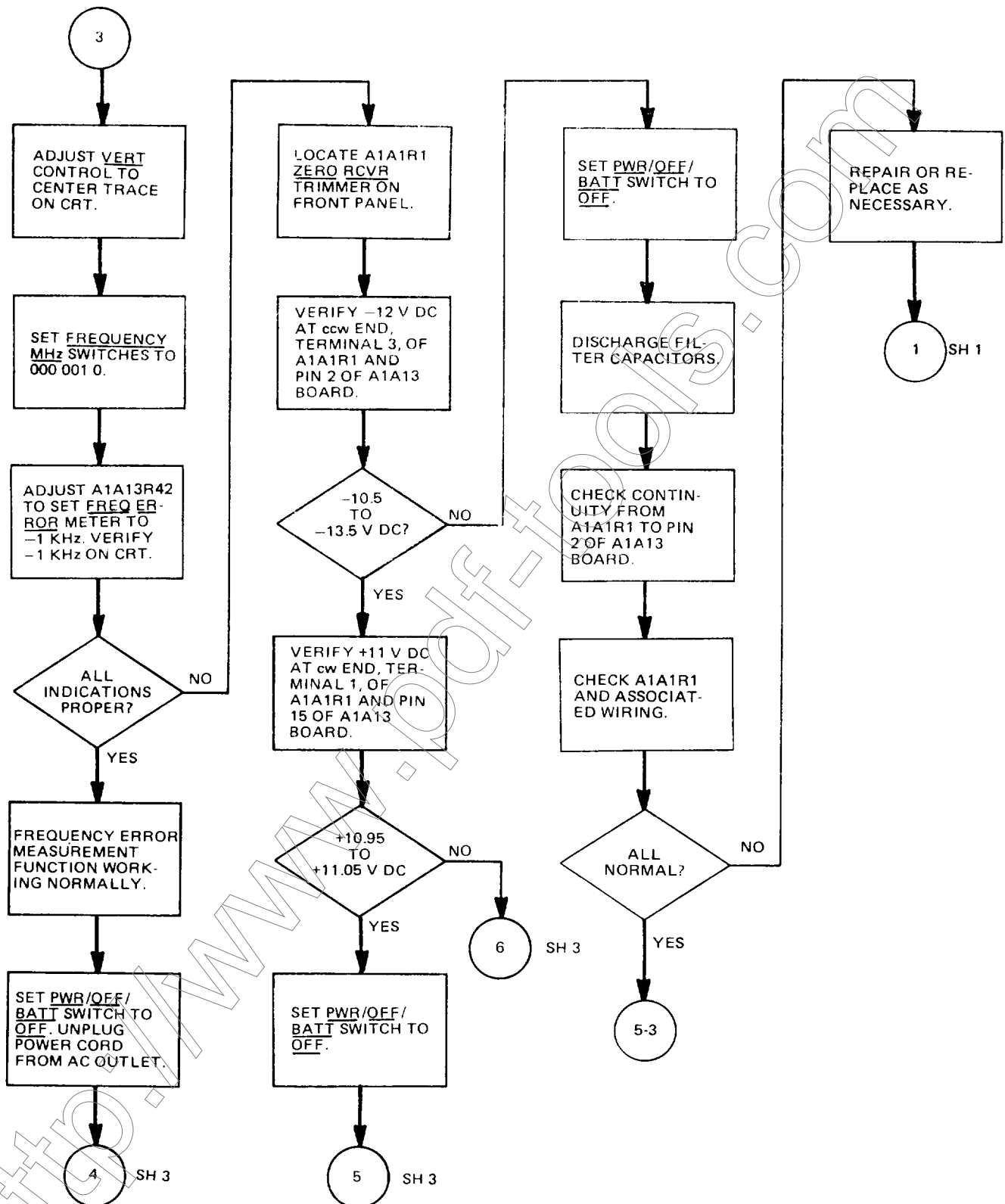


Figure 5-7. Frequency error measurement troubleshooting (sheet 2 of 3).

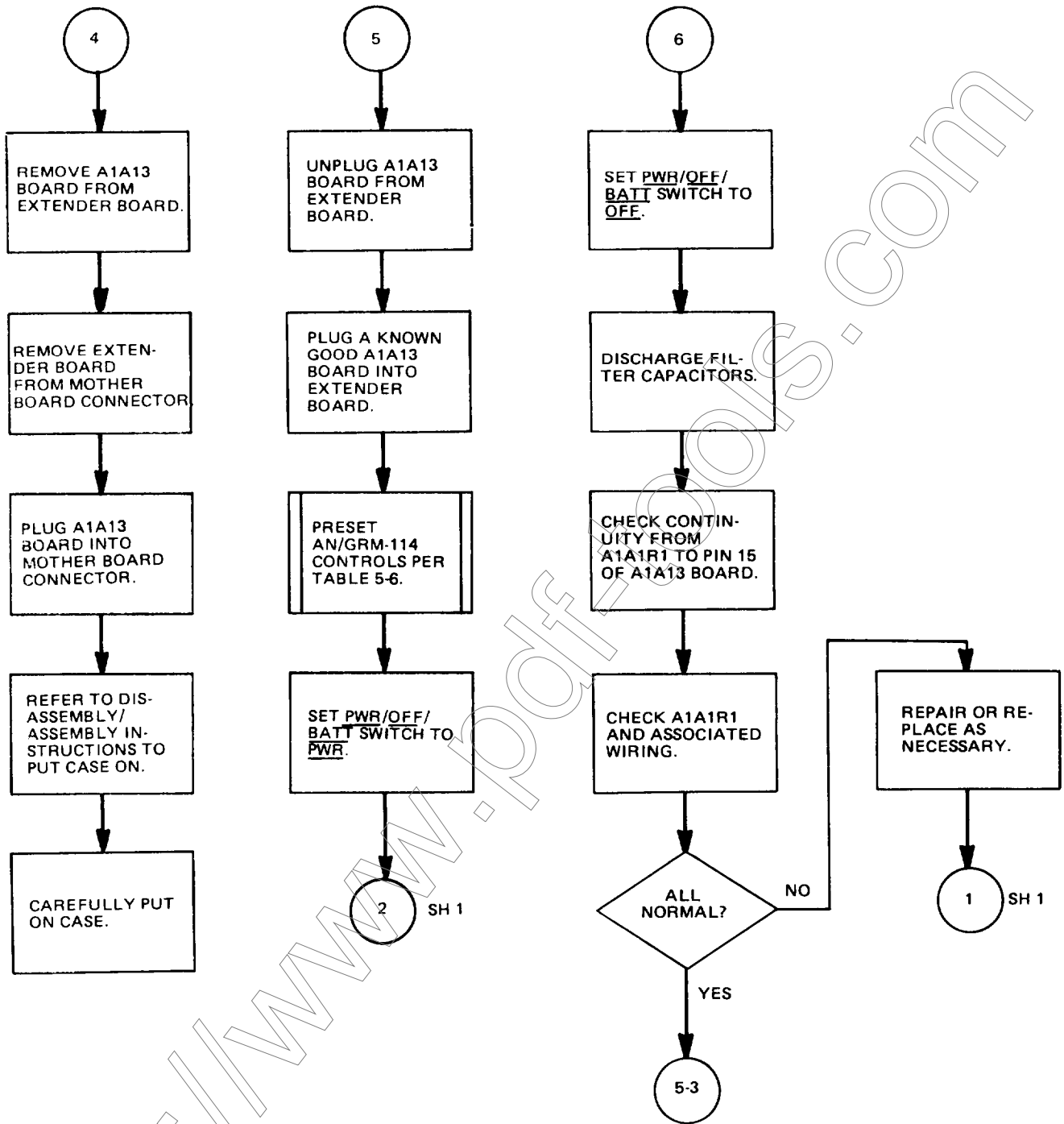


Figure 5-7. Frequency error measurement troubleshooting (sheet 3 of 3).

Table 5-9. RF Signal Generator Troubleshooting Initial Conditions

Control	Setting
INTENSITY	As required
EXT V/DIV	15 KHz
EXT V/DIV Vernier	CAL
AC/DC/OFF	DC
SWEEP	1 mS
SWEEP Vernier	CAL
MODULATION FREQ Hz	0000.0
INT MOD/OFF	OFF, fully ccw in detent
1 KHz INT MOD	OFF, fully ccw in detent
VERT	Midrange
ANALY DISPR	OFF, fully ccw in detent
HORIZ	Midrange
KHz	5
AM/FM	FM
BFO/OFF	OFF
VOL	Fully ccw
INT MOD/RCVR	RCVR
SQUELCH	Fully ccw, not in detent
DEV/PWR	SIG
GEN/RCVR	RCVR
RCVR WIDE/MID/NARROW	NARROW
RF LEVEL/BFO INJECTION	10 $\mu$ V
HI LVL/ $\mu$ V X 100/NORM	NORM
AUTO/OFF/ZERO, BATT	AUTO
PWR/OFF/BATT	PWR
FREQUENCY MHz	111 100 0

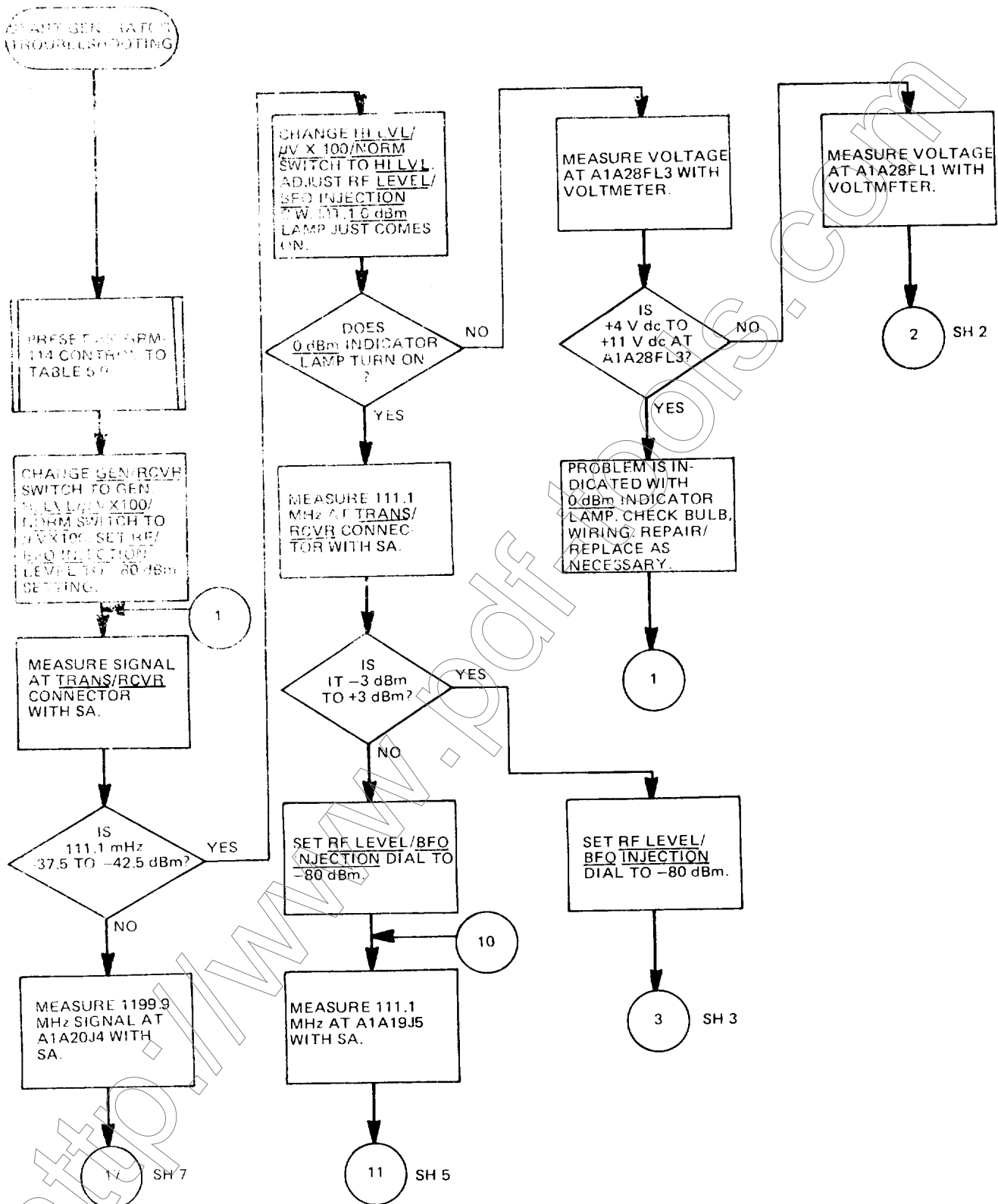


Figure 5-8. RF signal generator troubleshooting (sheet 1 of 19)

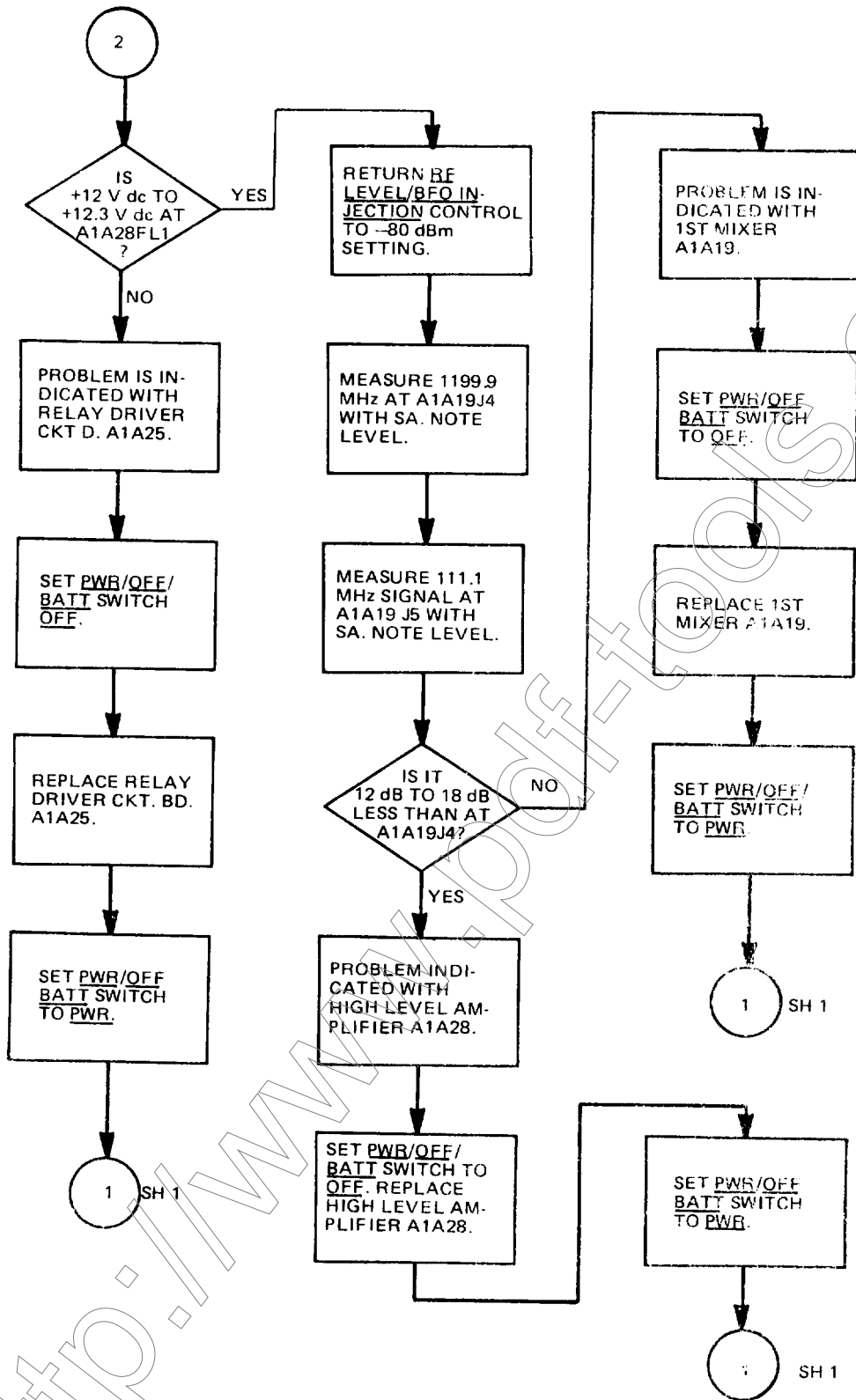


Figure 5-8. RF signal generator troubleshooting (sheet 2 of 19)



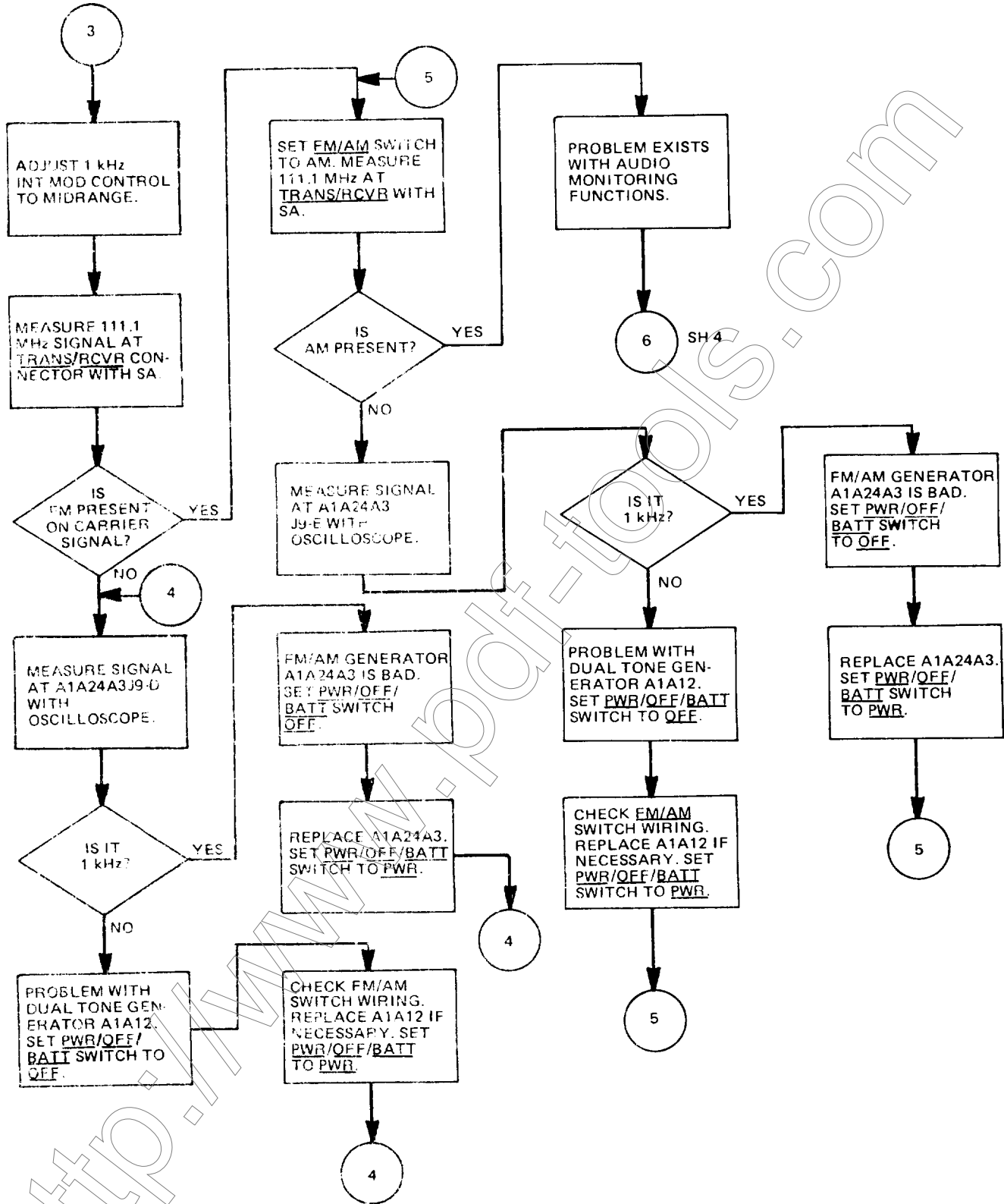


Figure 5-8. RF signal generator troubleshooting (sheet 3 of 19)

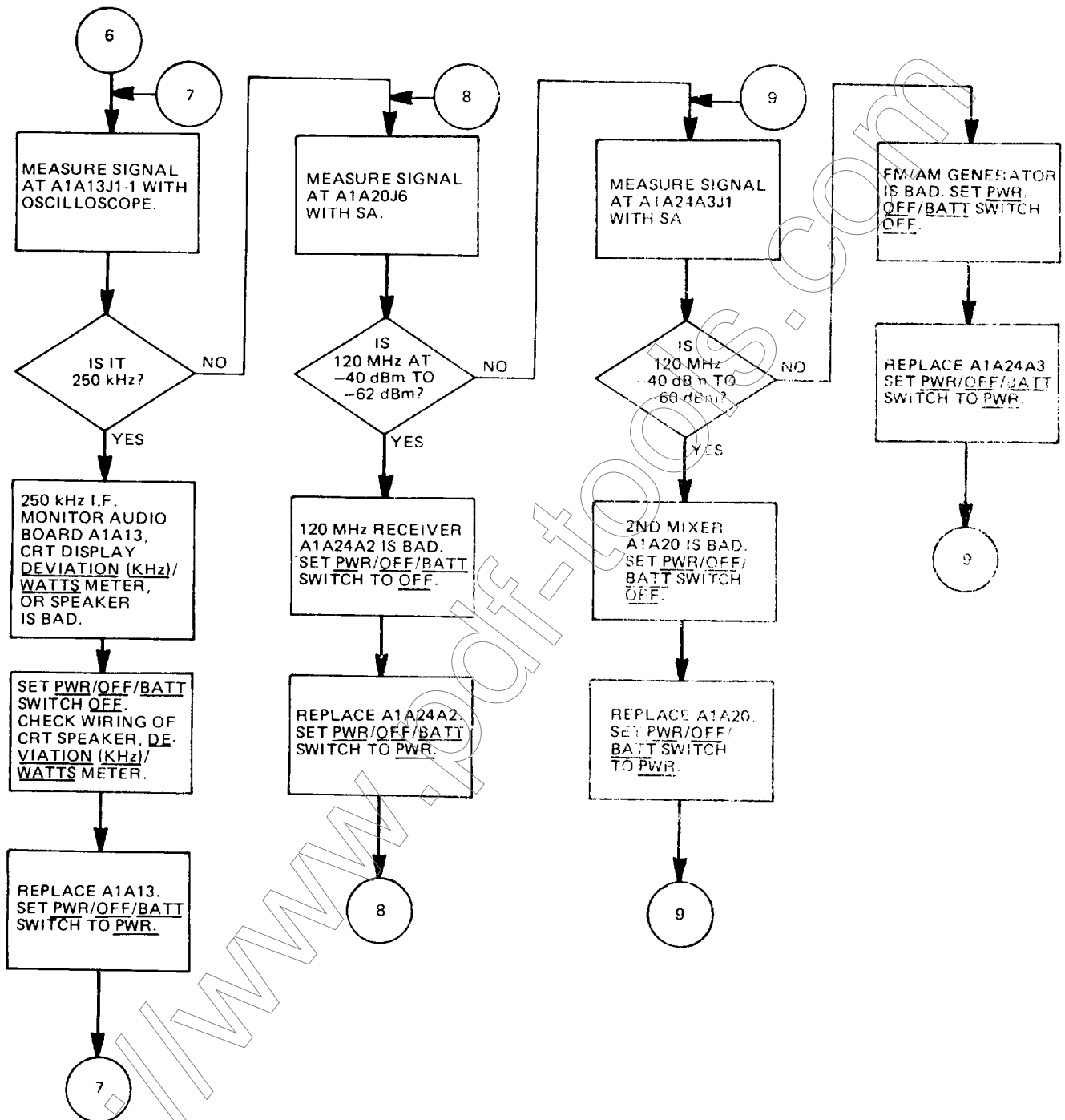


Figure 5-8. RF signal generator troubleshooting (sheet 4 of 19)

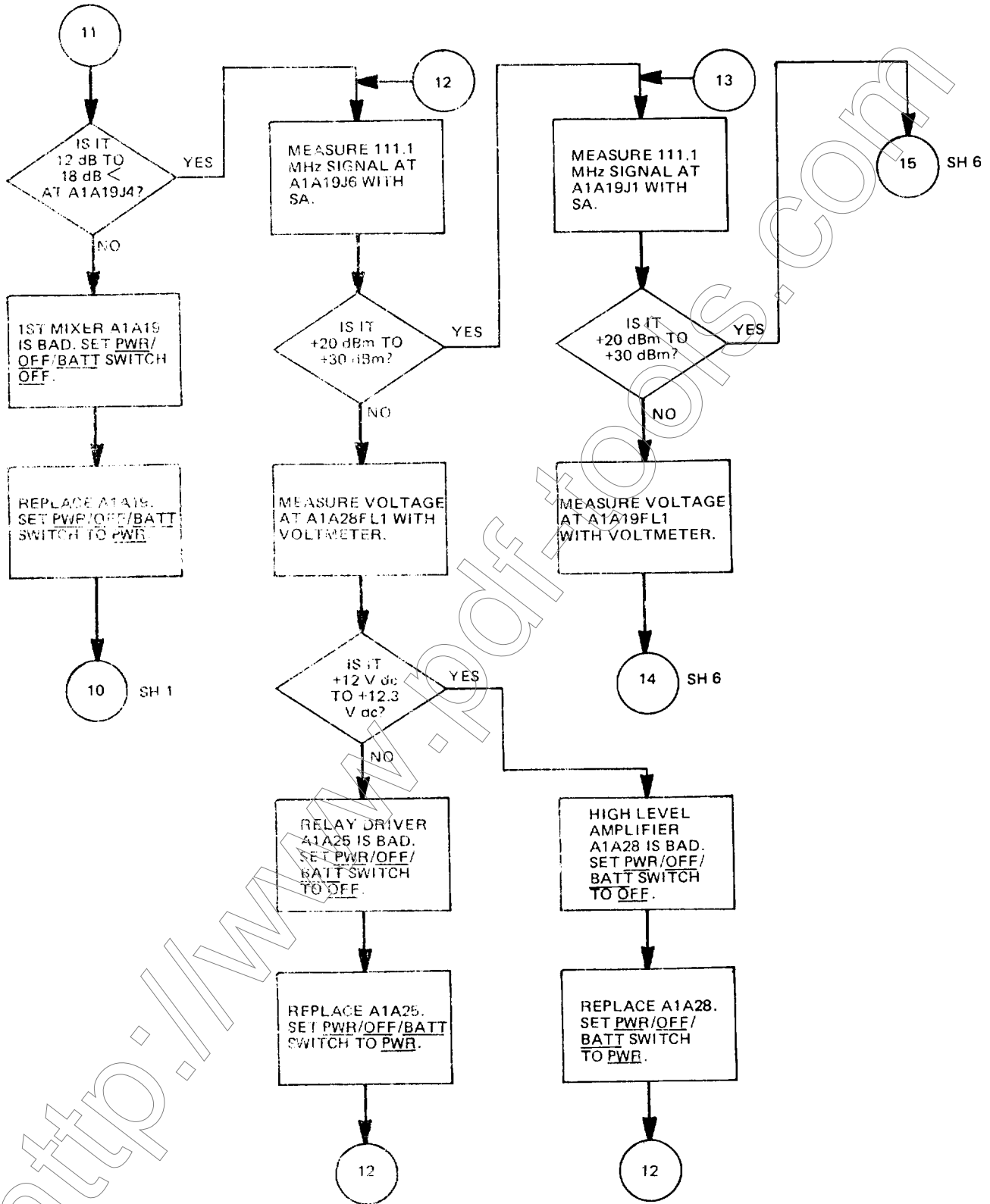


Figure 5-8. RF signal generator troubleshooting (sheet 5 of 19)

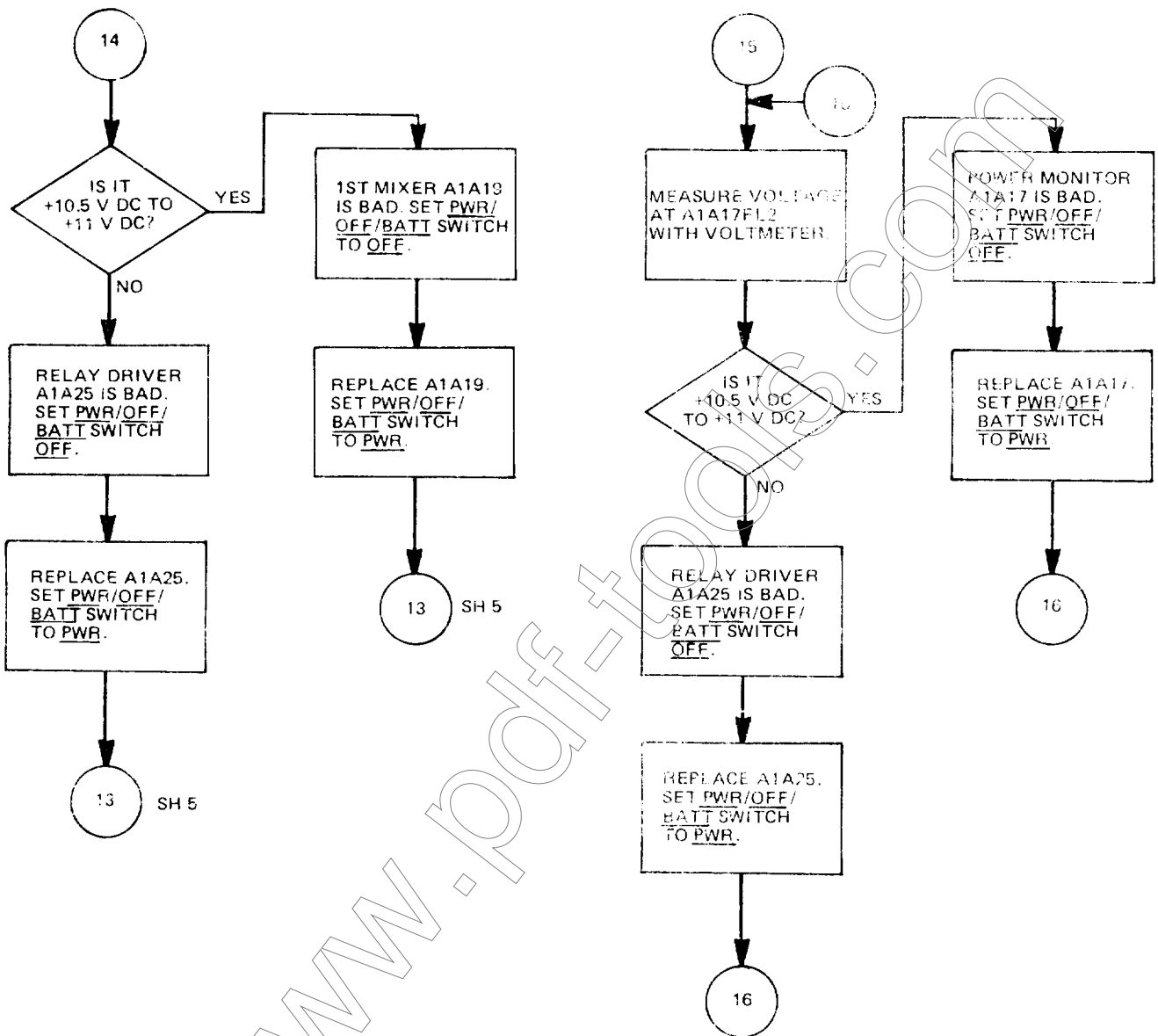


Figure 5-8. RF signal generator troubleshooting (sheet 6 of 19)

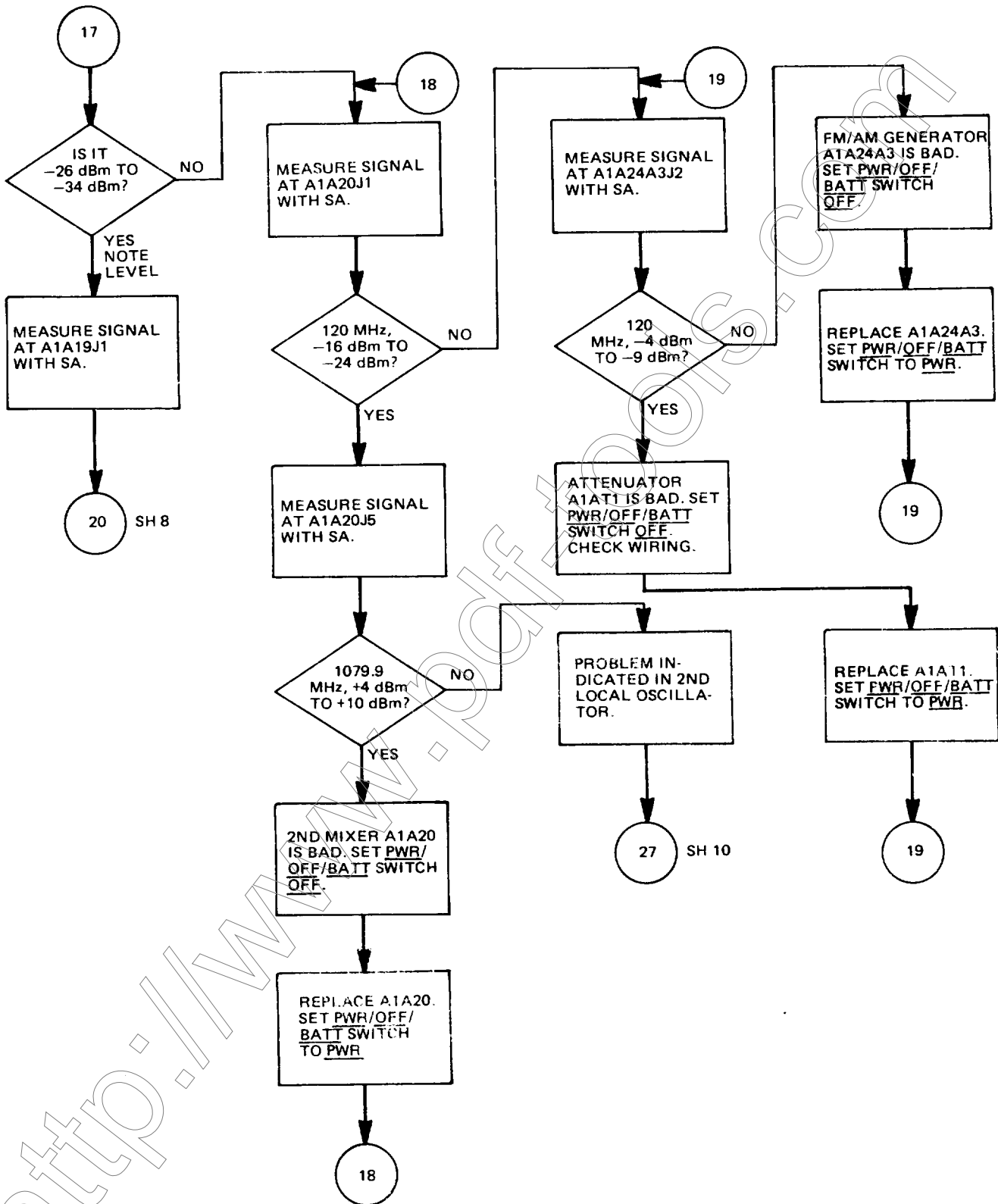


Figure 5-8. RF signal generator troubleshooting (sheet 7 of 19)

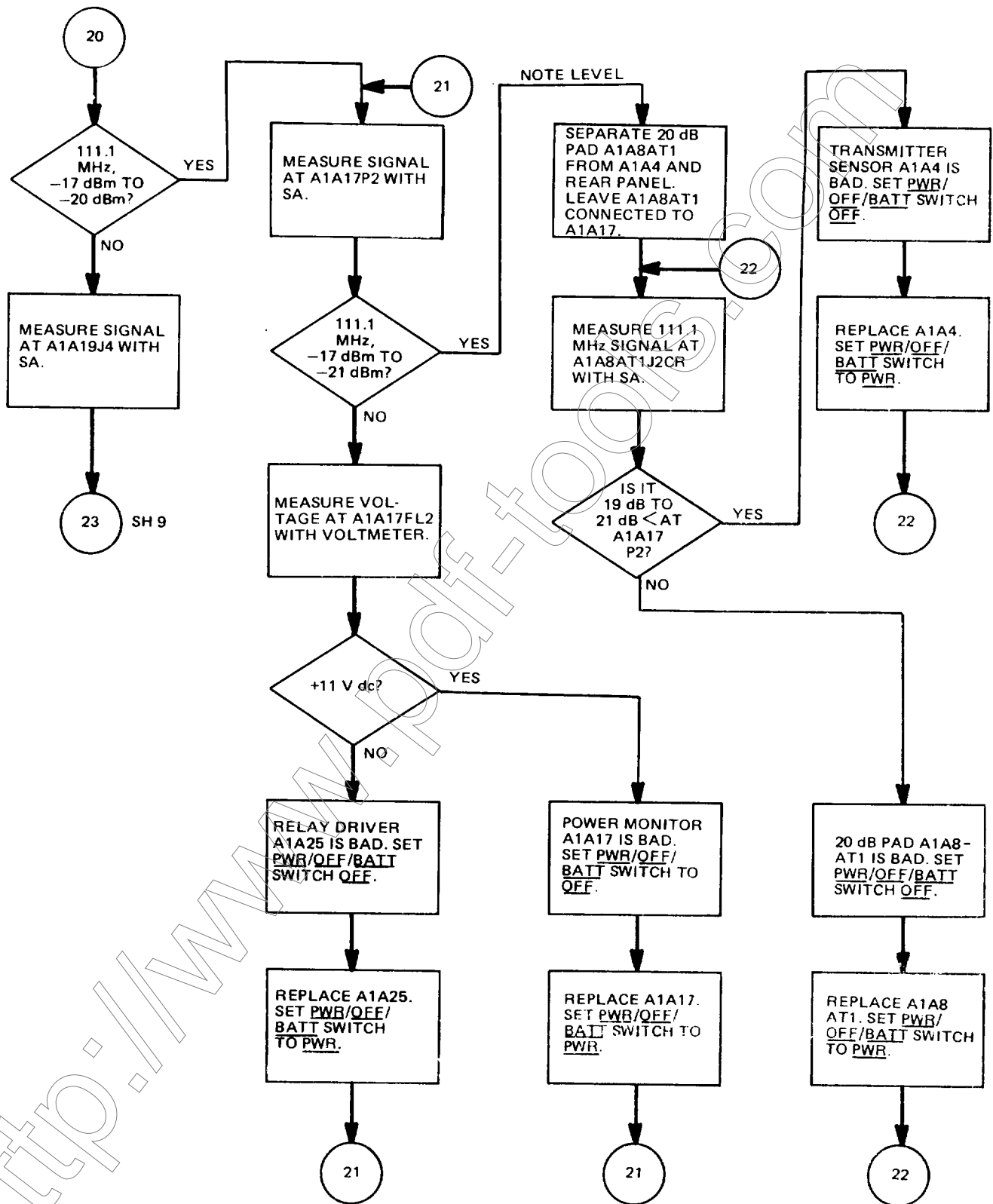


Figure 5-8. RF signal generator troubleshooting (sheet 8 of 19)

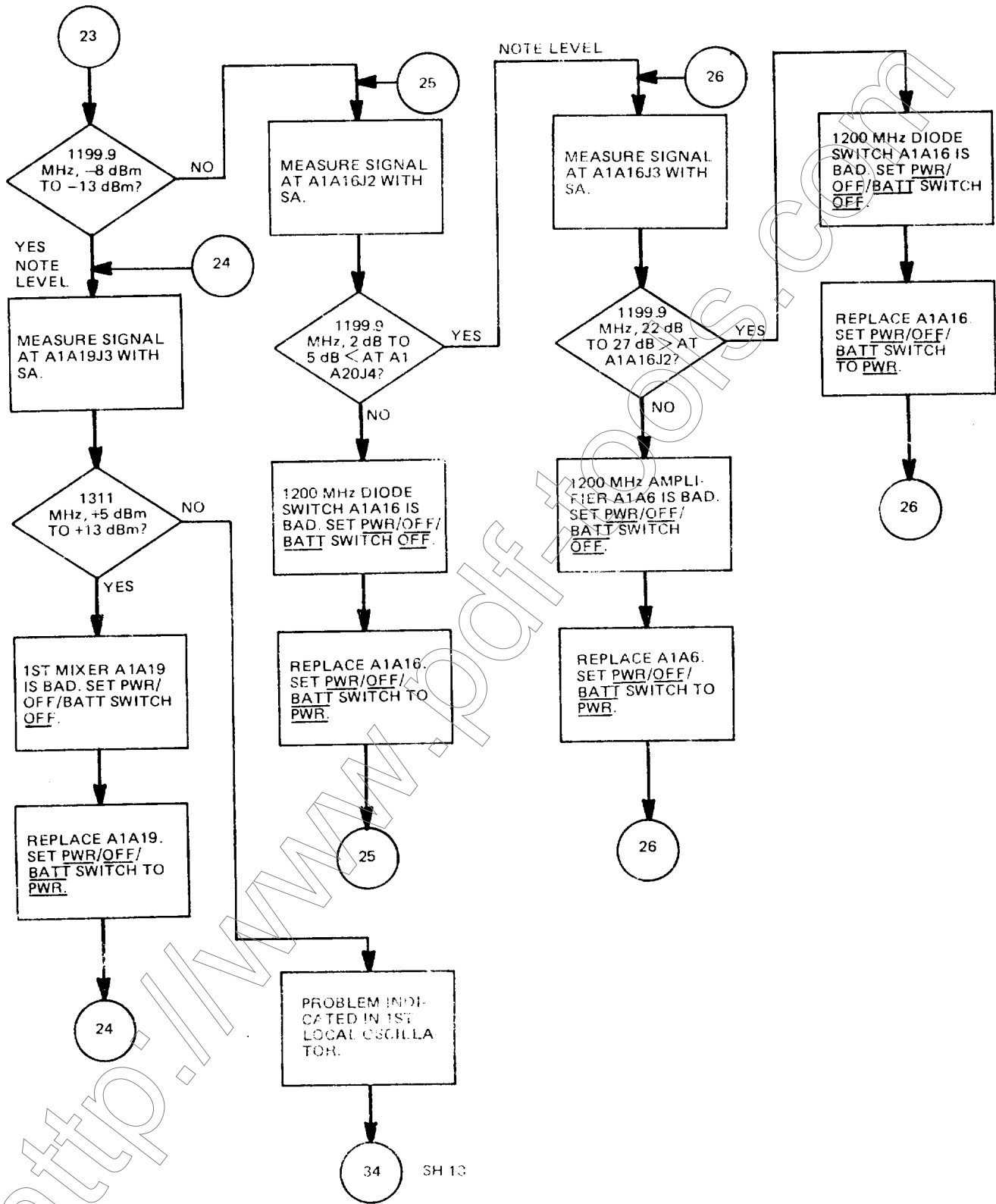


Figure 5-8. RF signal generator troubleshooting (sheet 9 of 19)

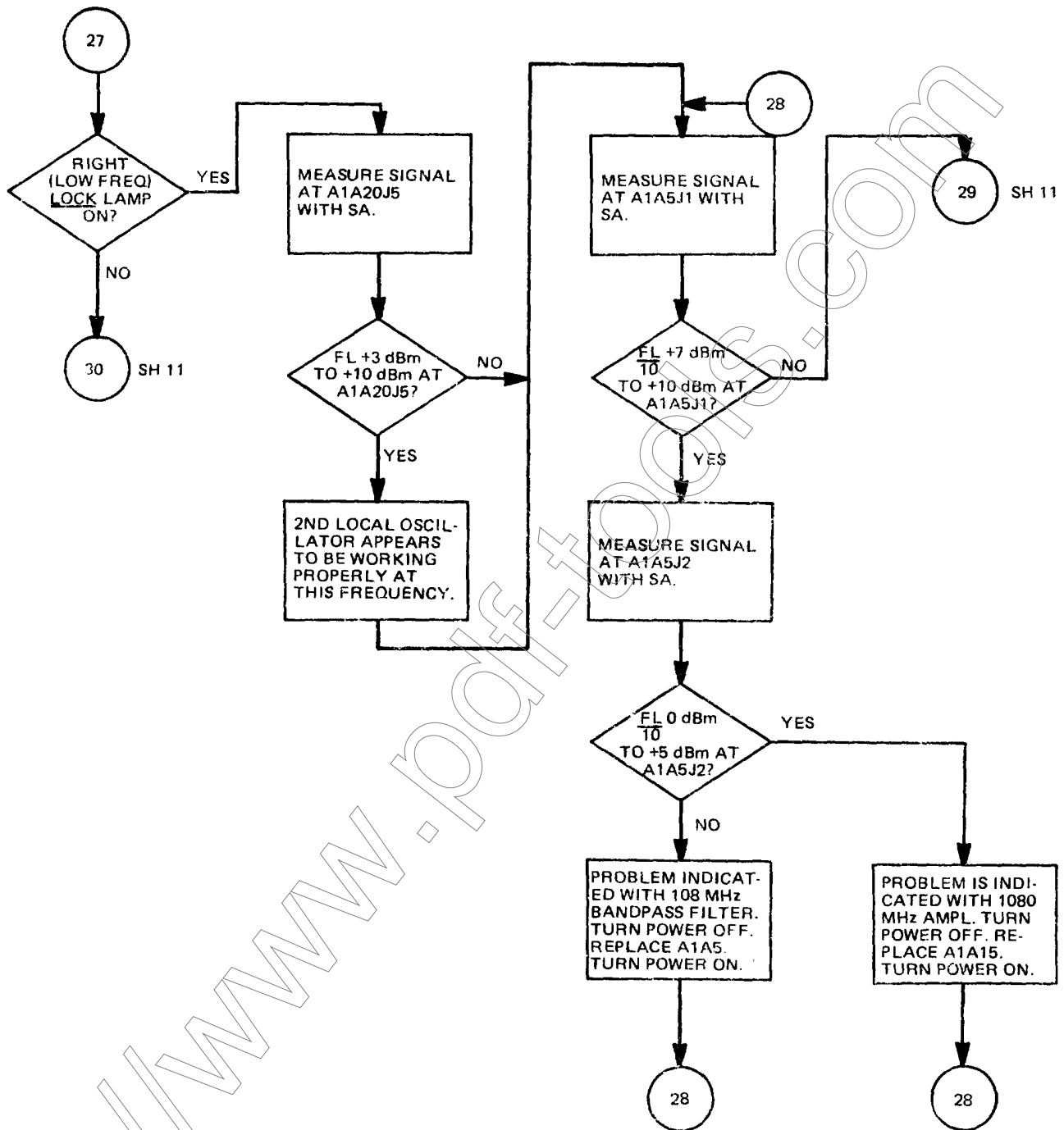


Figure 5-8. RF signal generator troubleshooting (sheet 10 of 19)



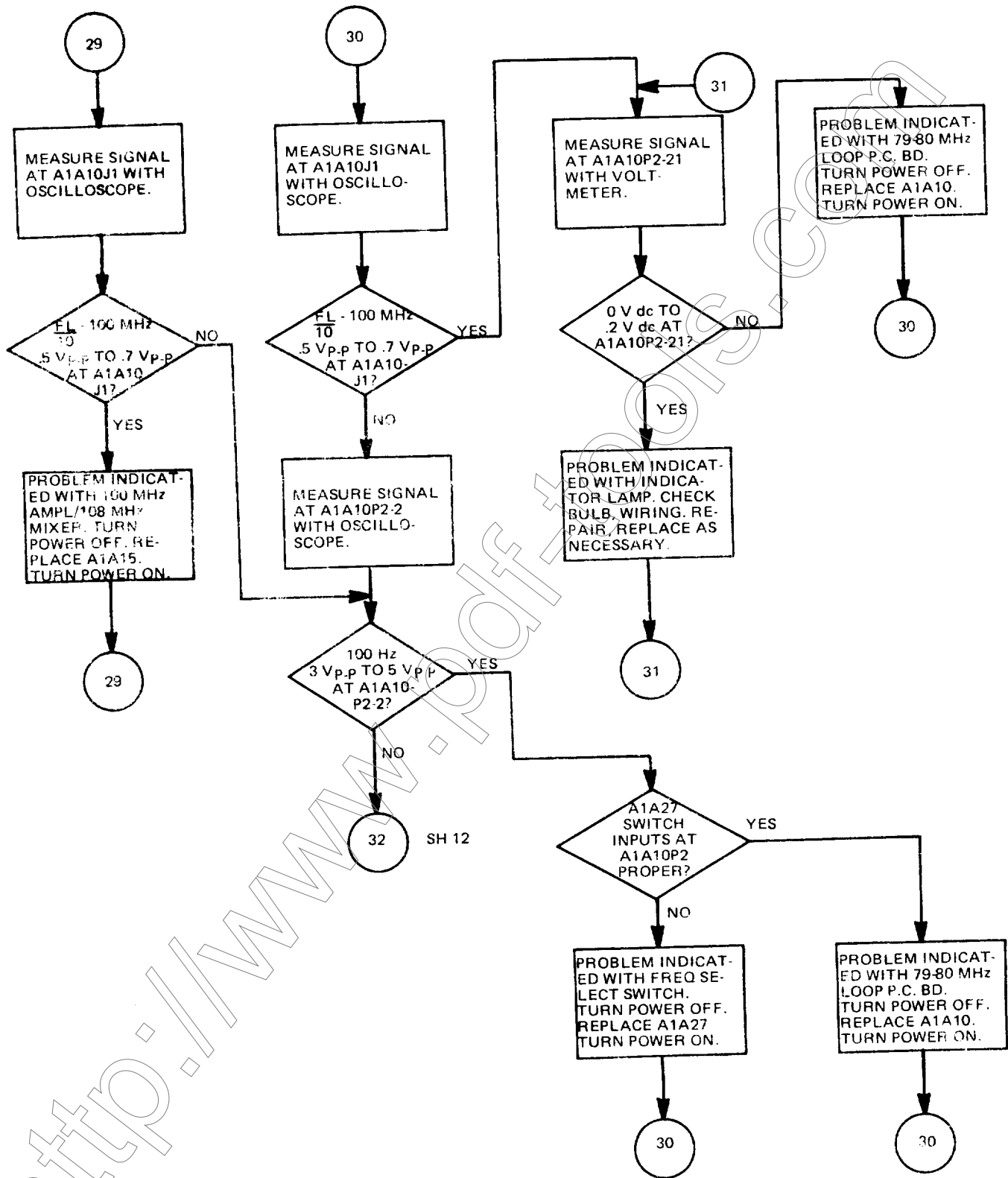


Figure 5-8. RF signal generator troubleshooting (sheet 11 of 19)

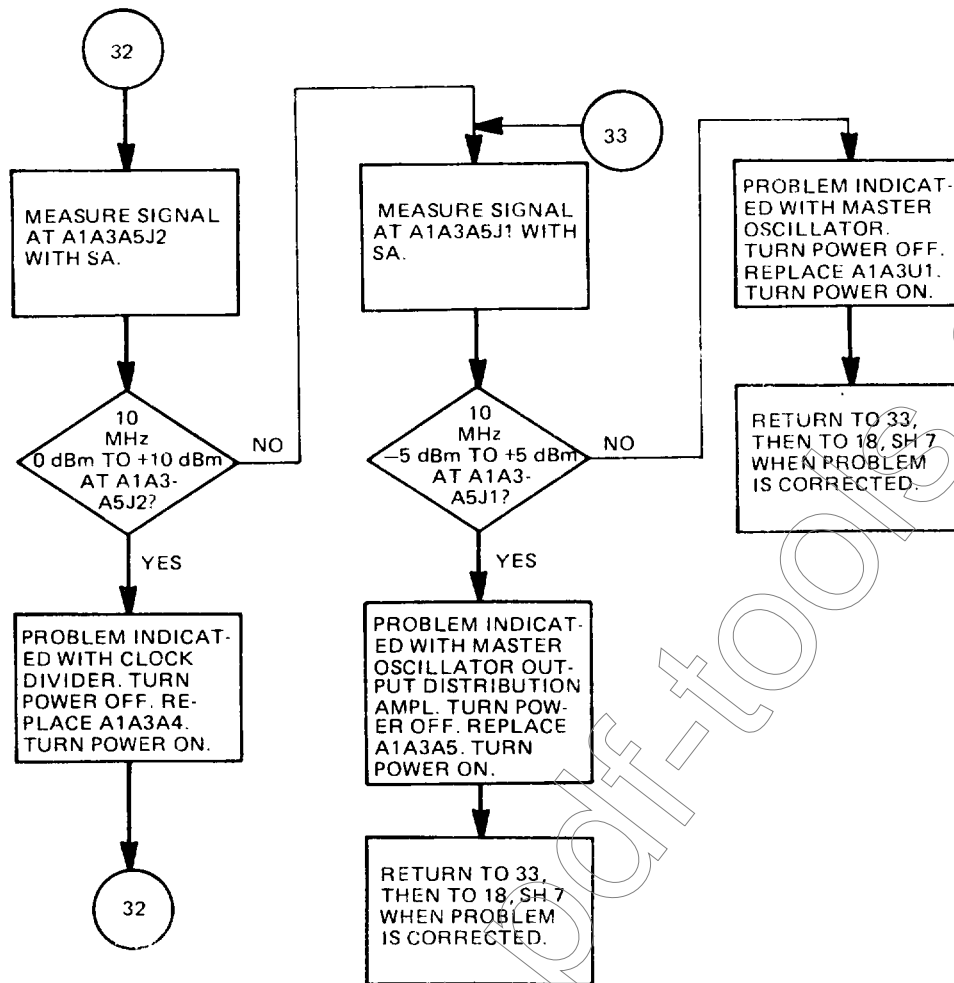


Figure 5-8. RF signal generator troubleshooting (sheet 12 of 19)

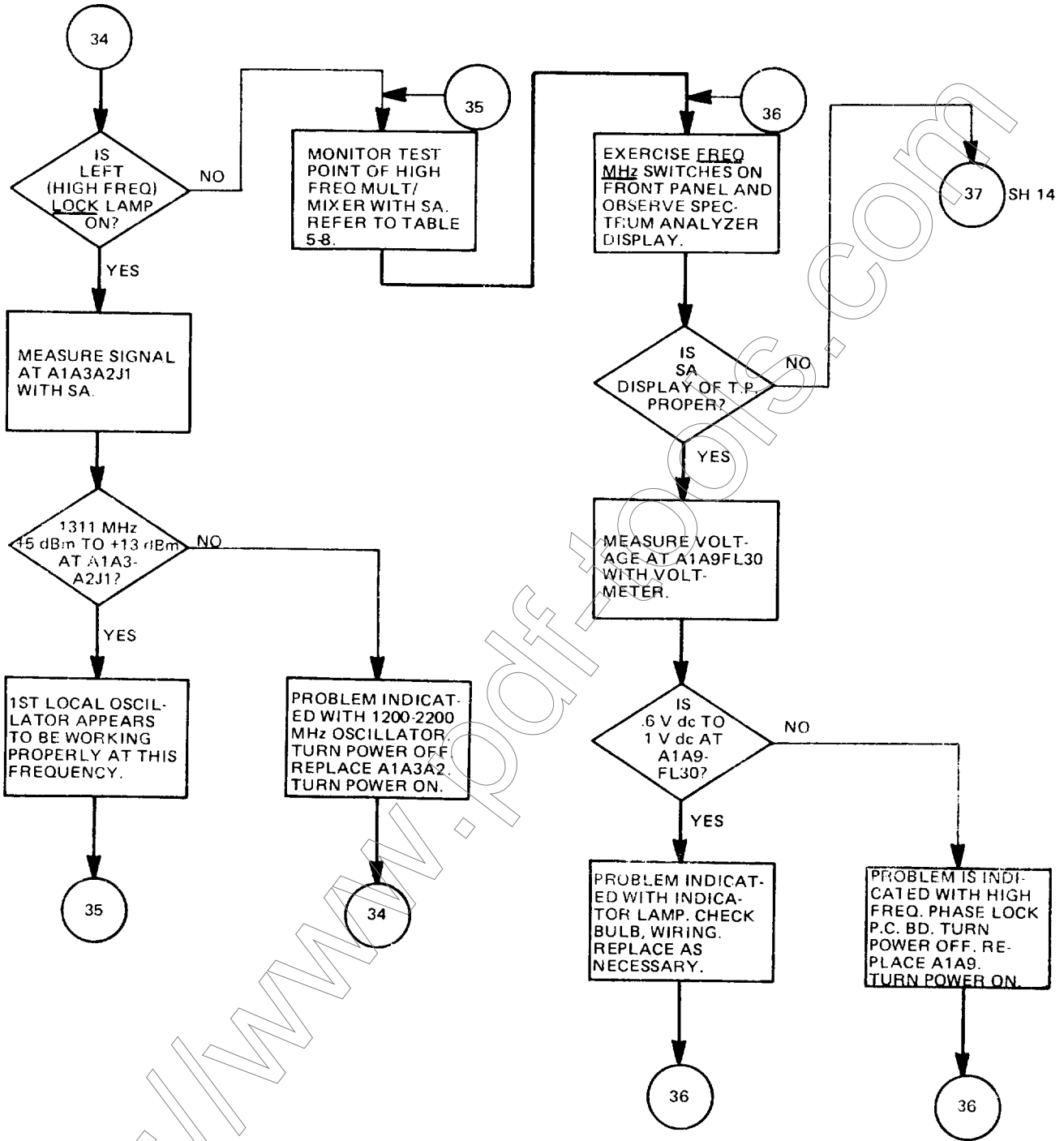


Figure 5-8. RF signal generator troubleshooting (sheet 13 of 19)

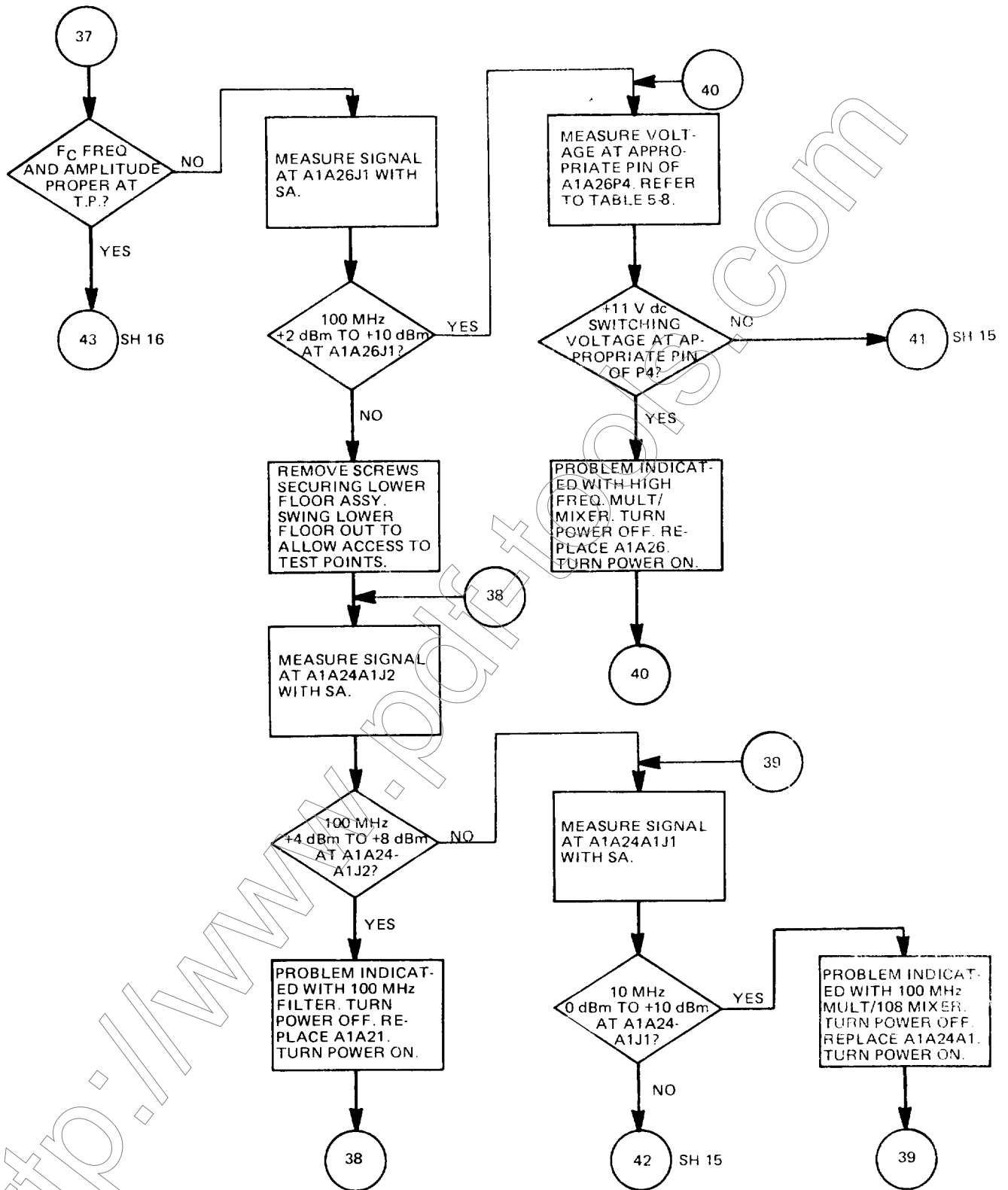


Figure 5-8. RF signal generator troubleshooting (sheet 14 of 19)

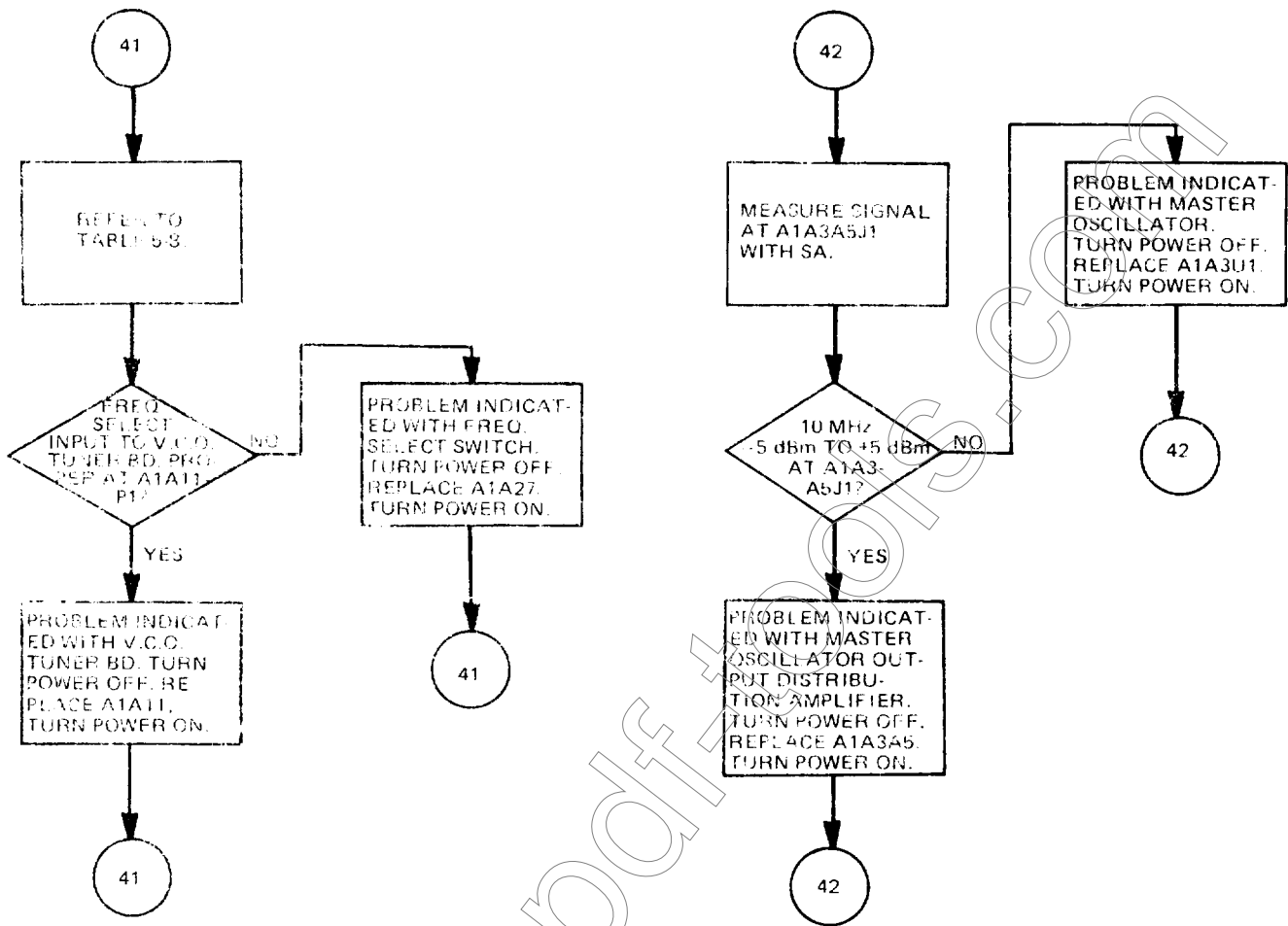


Figure 5-8. RF signal generator troubleshooting (sheet 15 of 19)

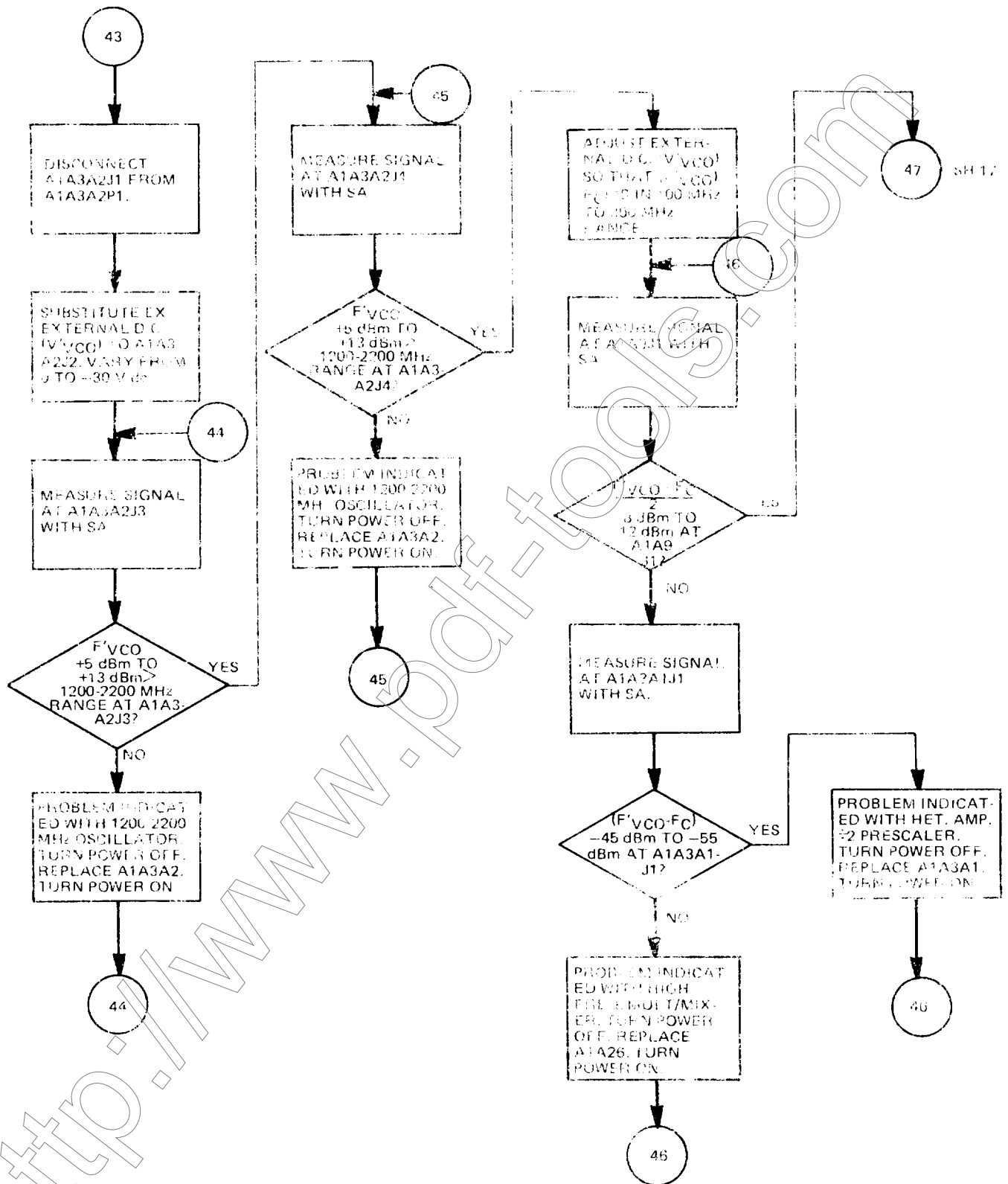


Figure 5-8. RF signal generator troubleshooting (sheet 16 of 19)

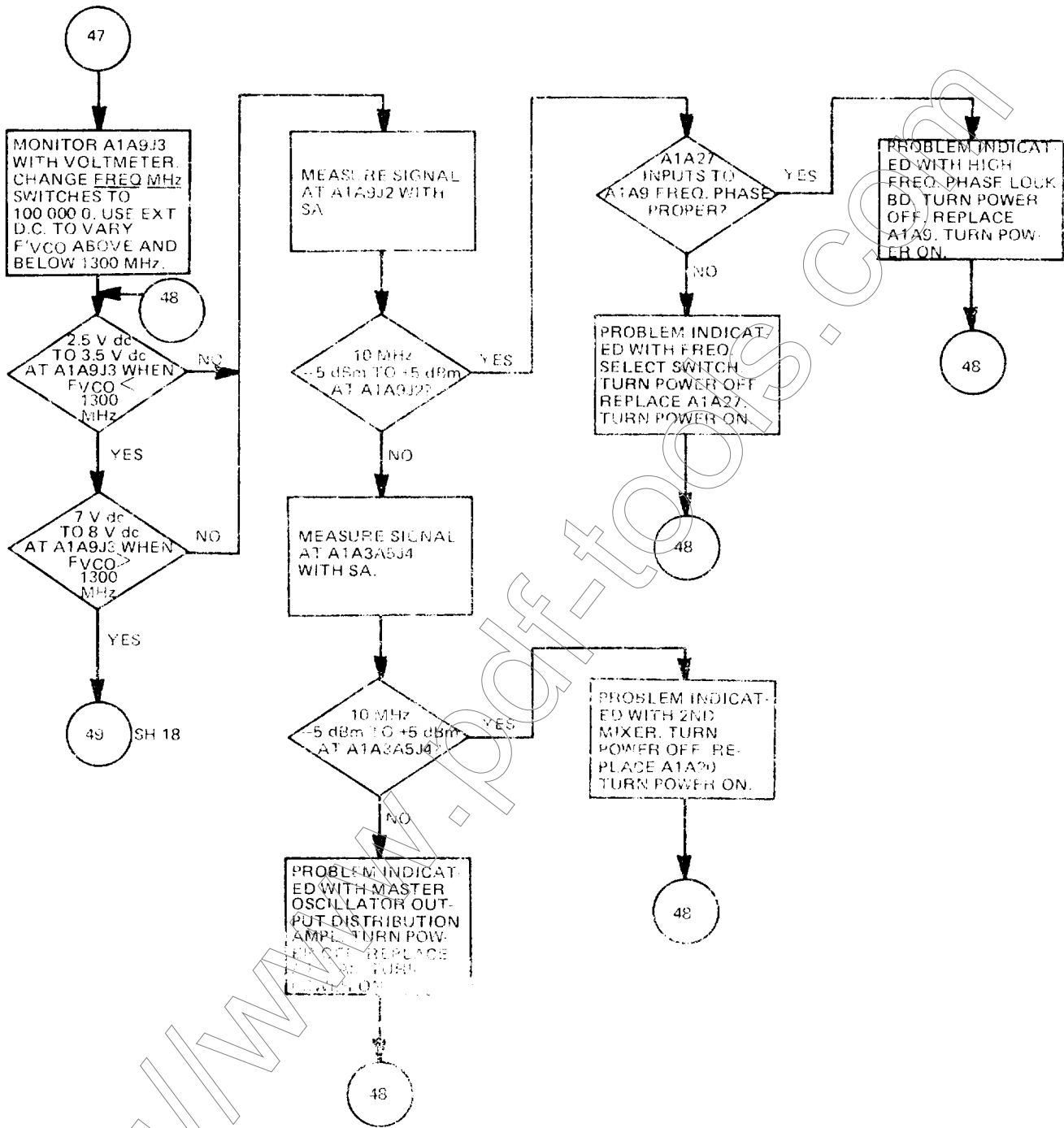


Figure 5-8. RF signal generator troubleshooting (sheet 17 of 19)

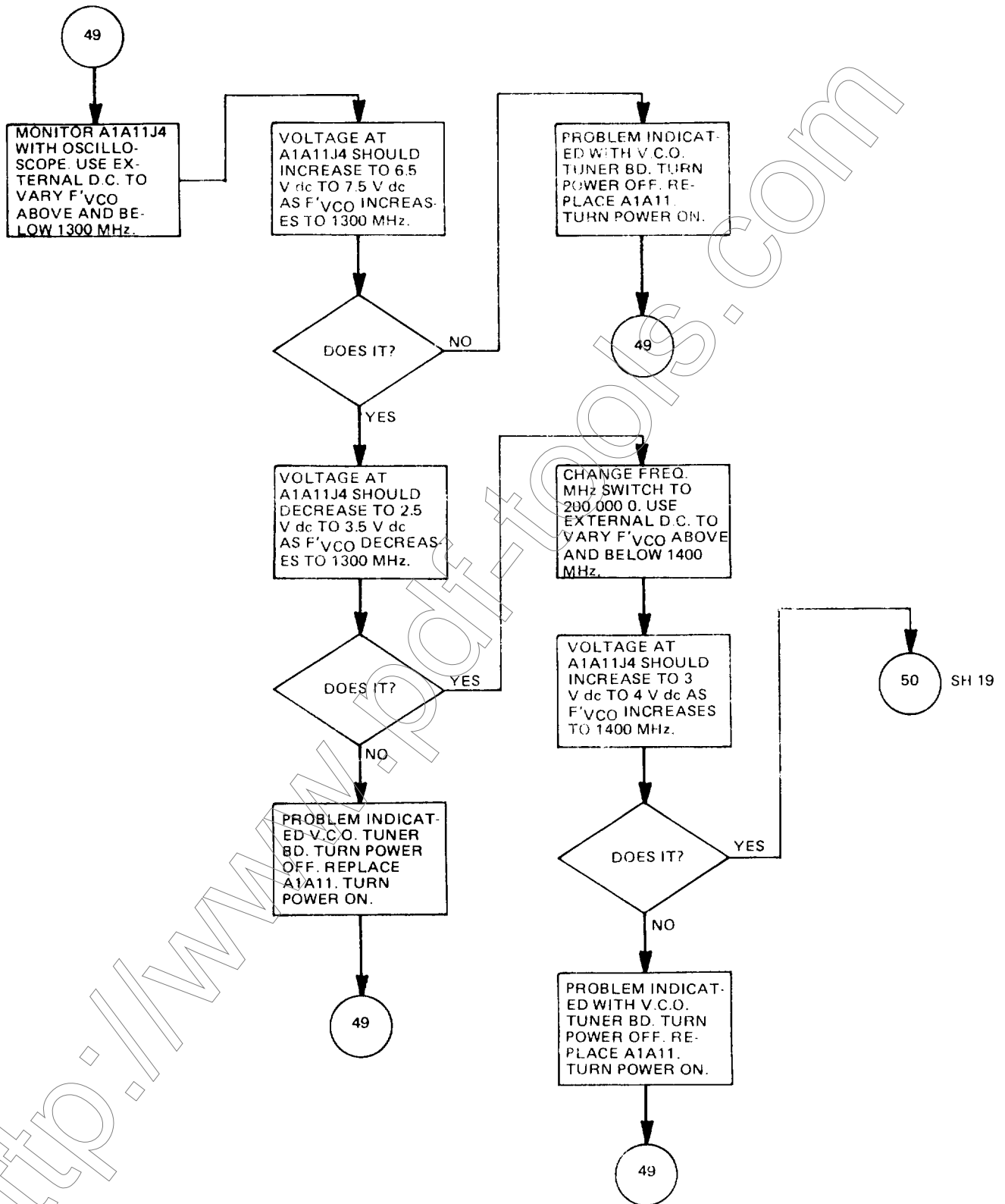


Figure 5-8. RF signal generator troubleshooting (sheet 18 of 19)



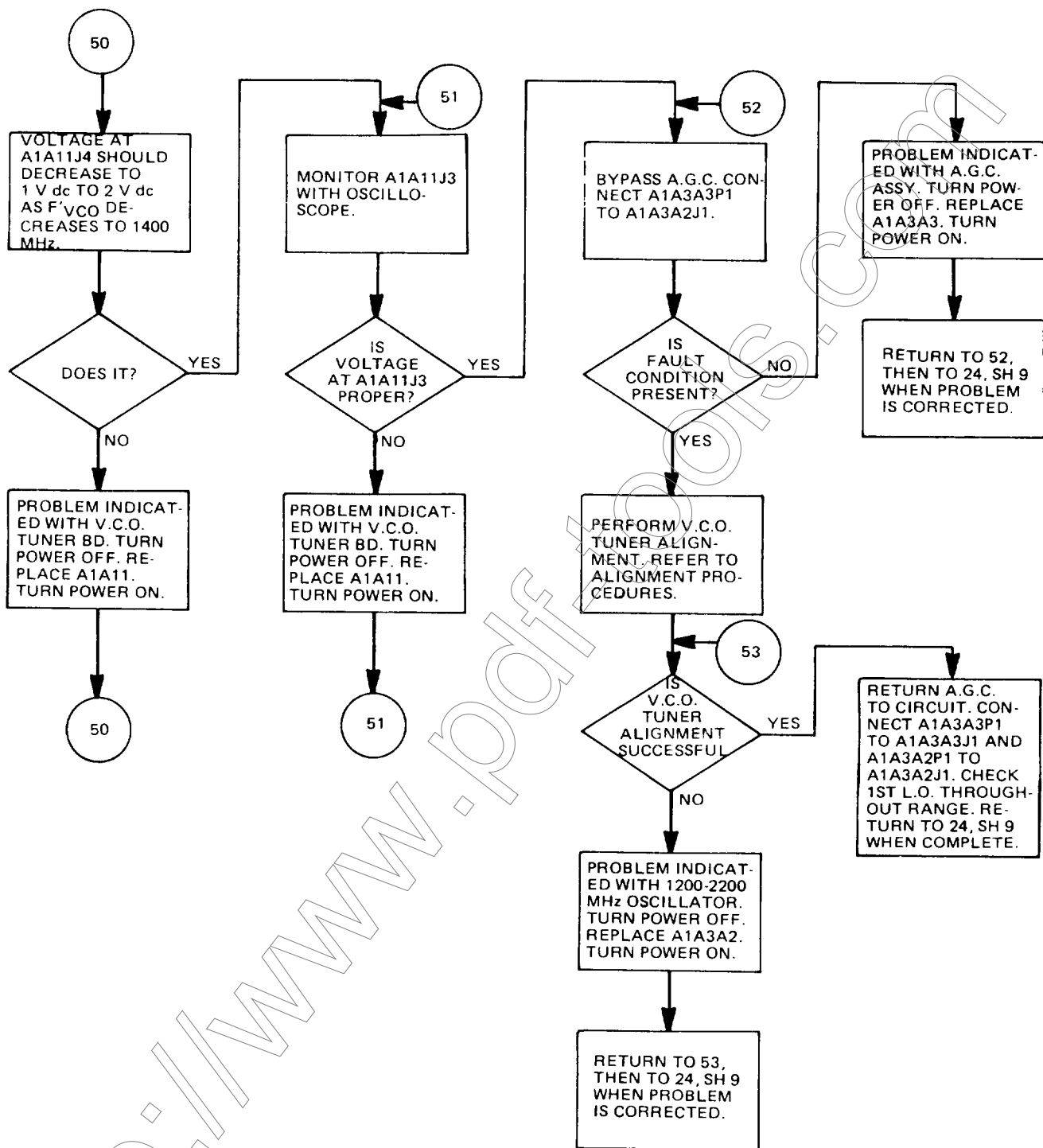


Figure 5-8. RF signal generator troubleshooting (sheet 19 of 19)

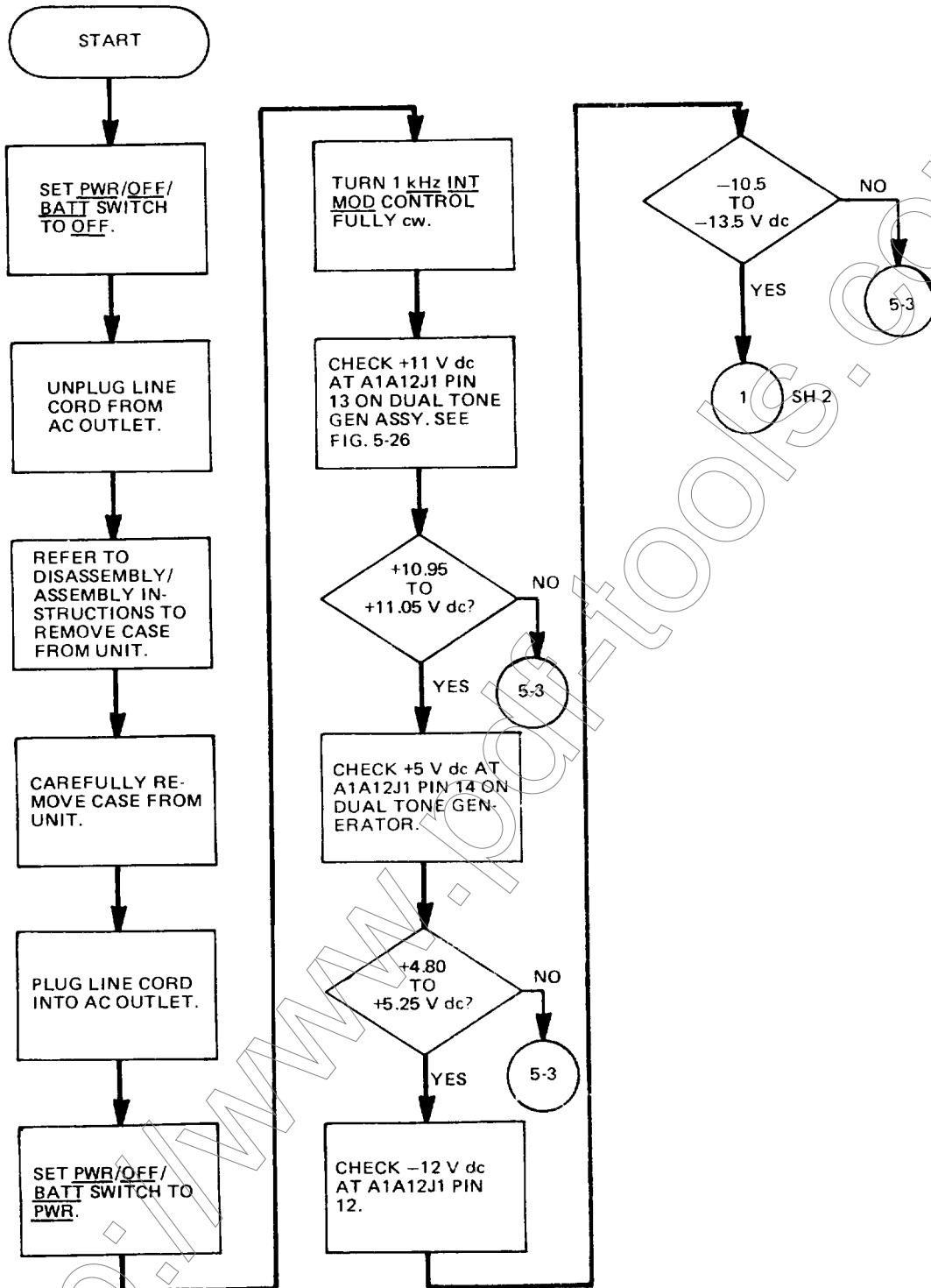


Figure 5-9. Dual tone generator - troubleshooting (sheet 1 of 3)

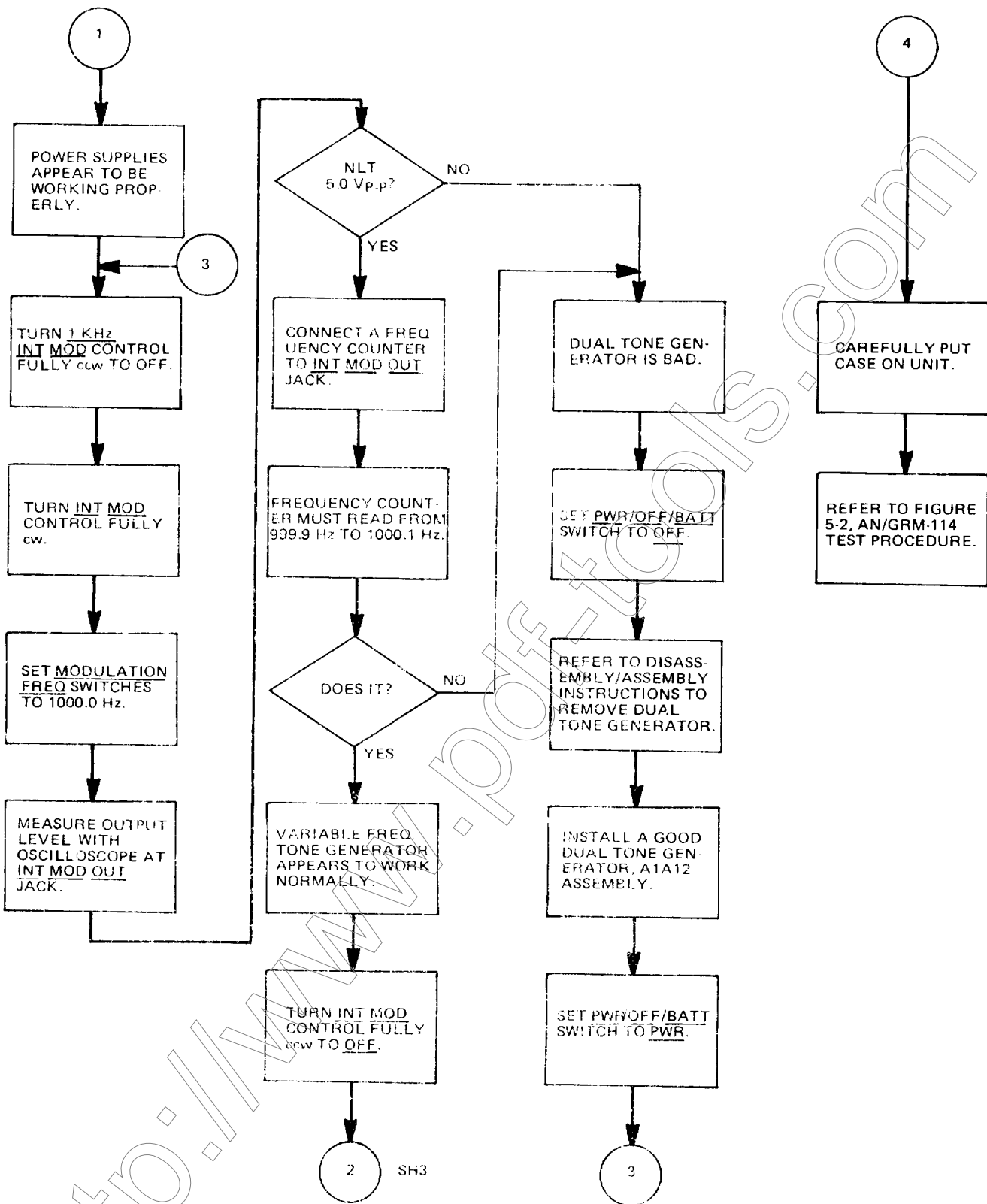


Figure 5-9. Dual tone generator - troubleshooting (sheet 2 of 3)

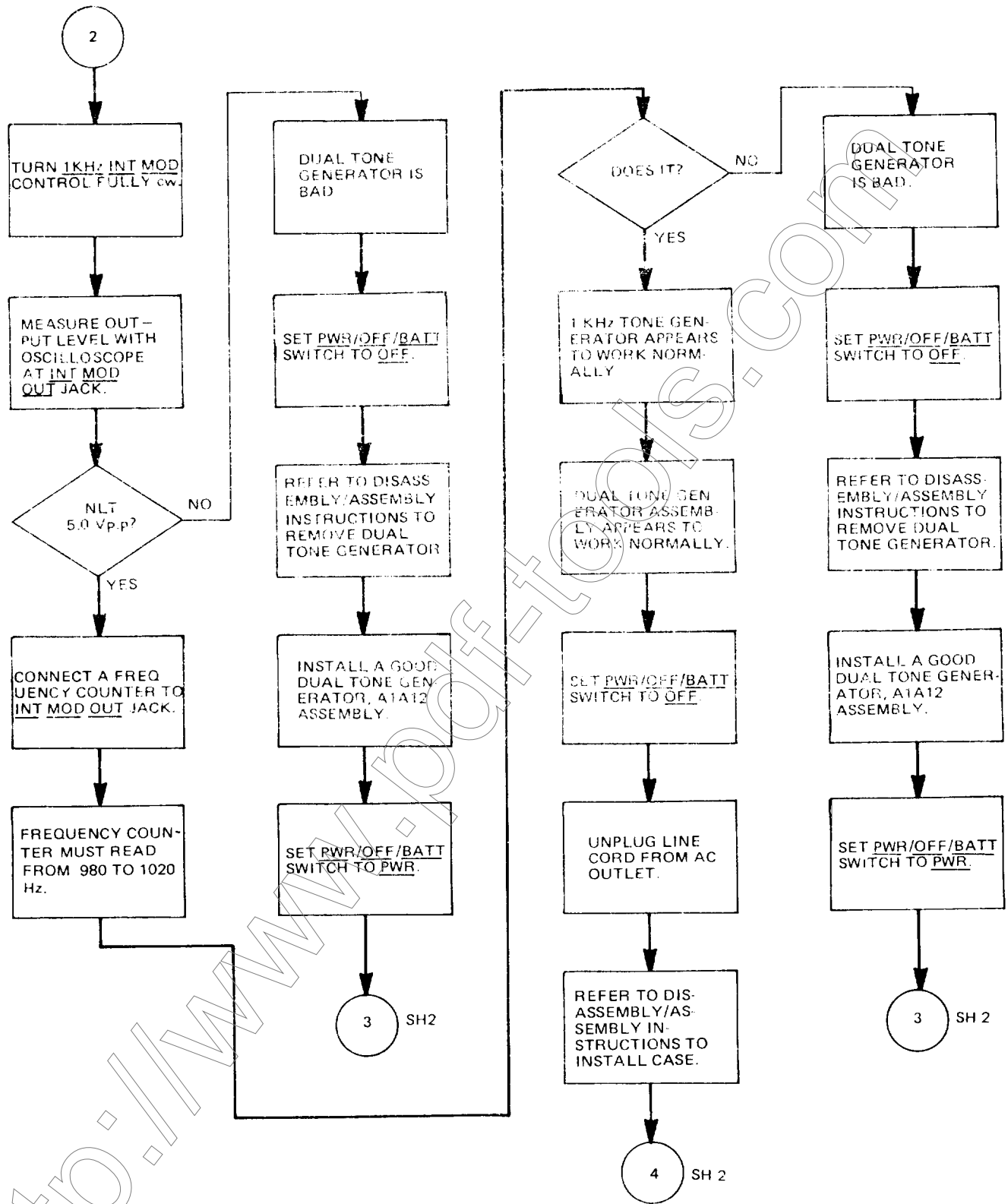


Figure 5-9. Dual tone generator - troubleshooting (sheet 3 of 3)

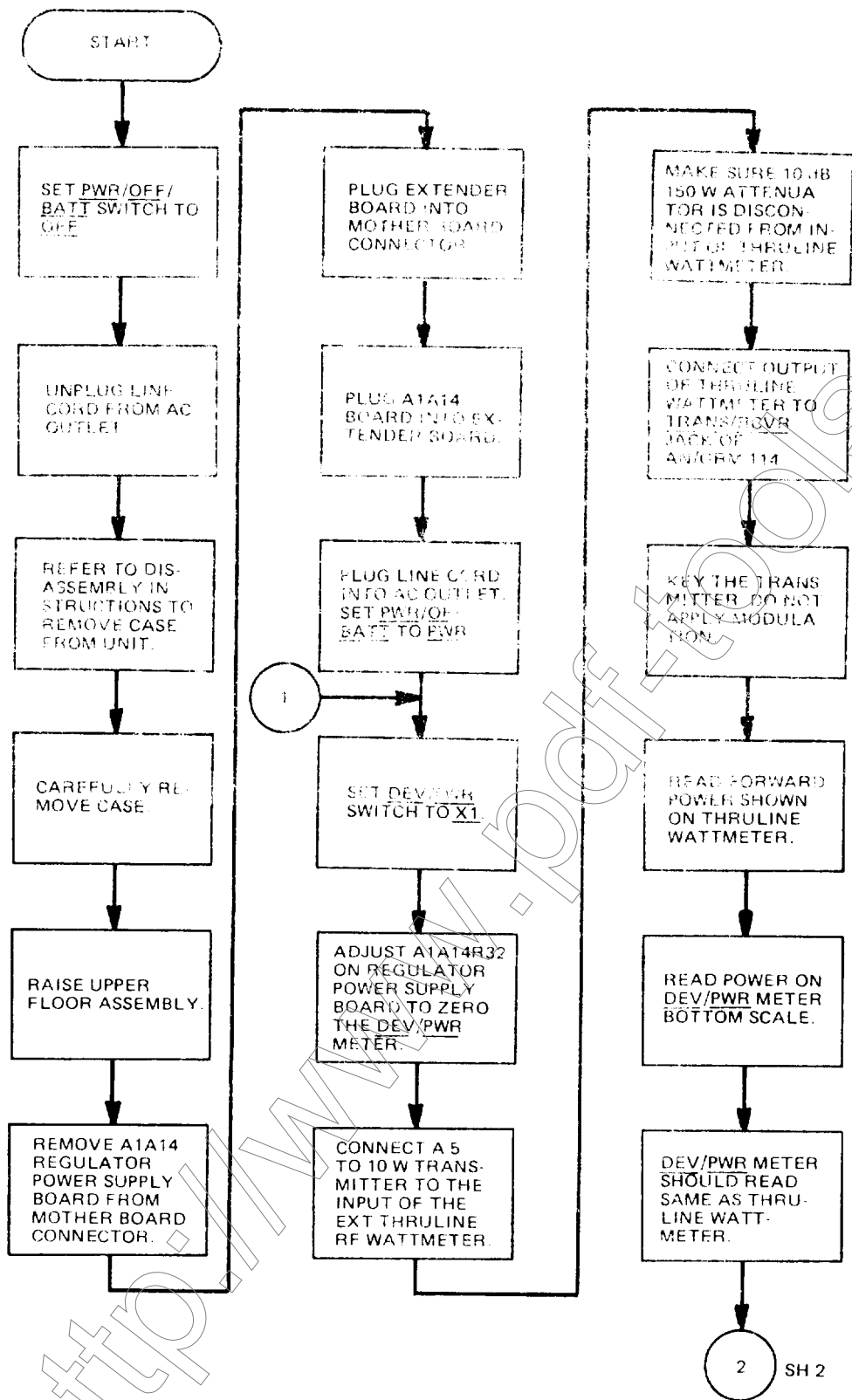


Figure 5-10. RF wattmeter troubleshooting (sheet 1 of 4)

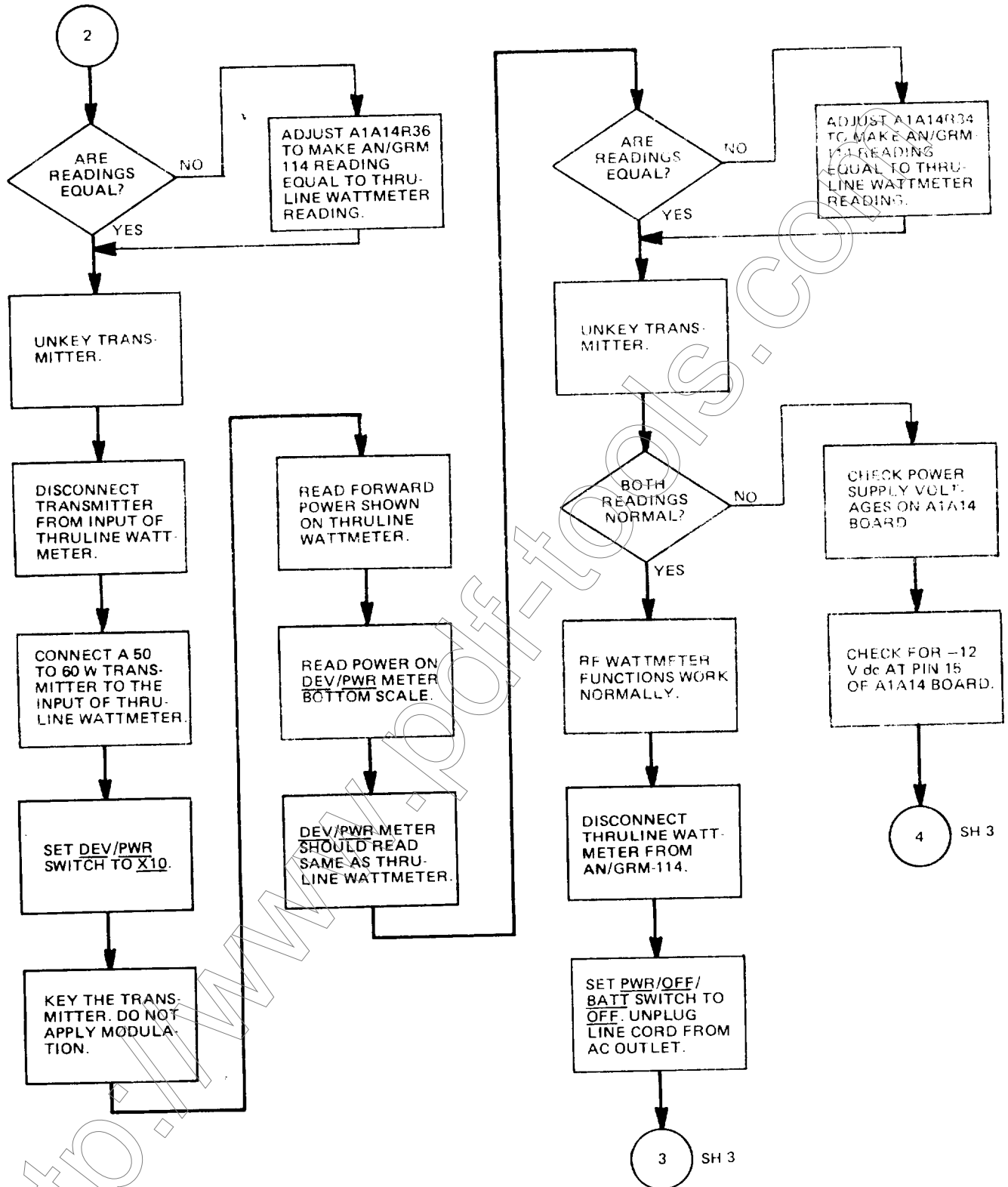


Figure 5-10. RF wattmeter troubleshooting (sheet 2 of 4)

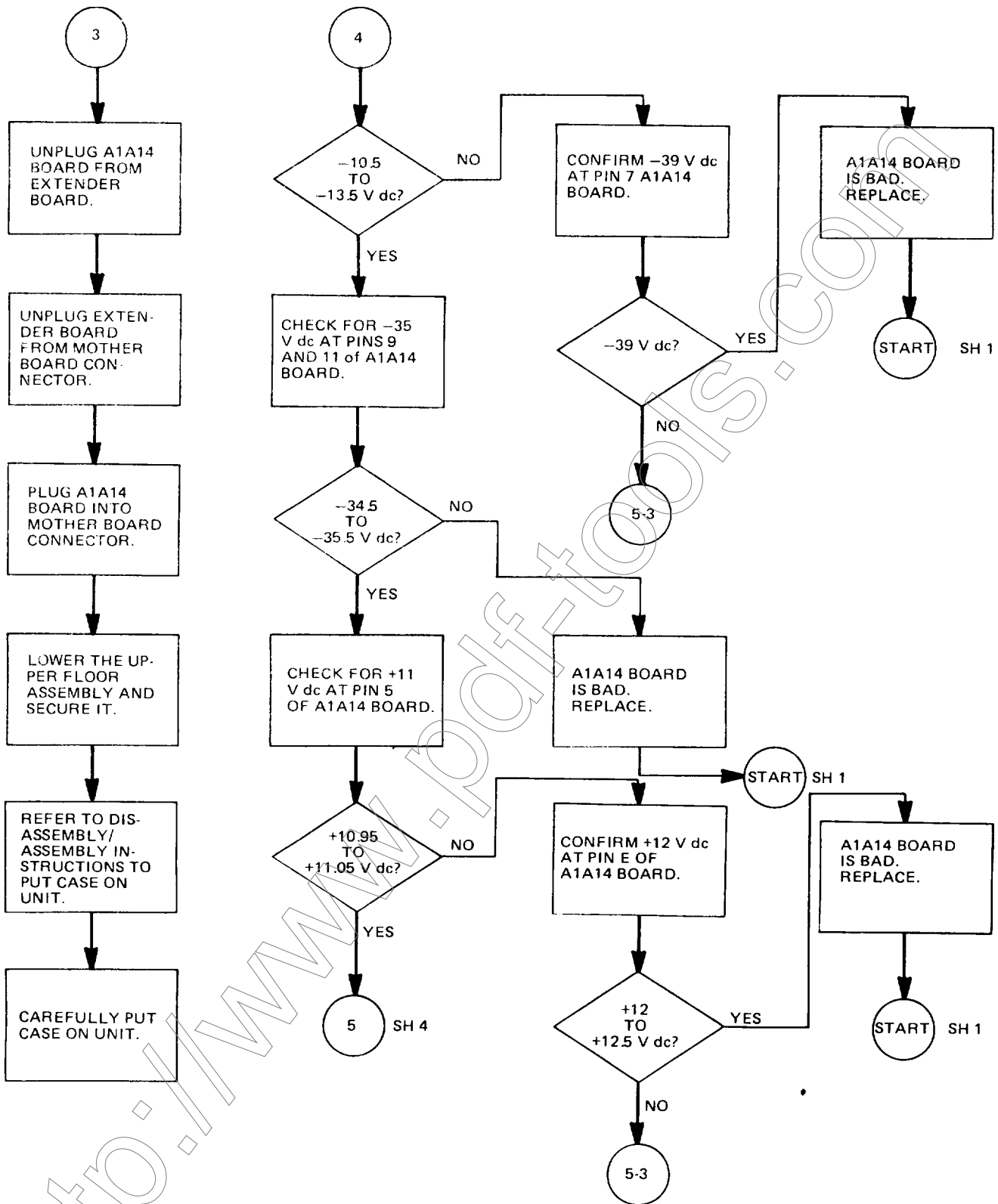


Figure 5-10. RF wattmeter troubleshooting (sheet 3 of 4)

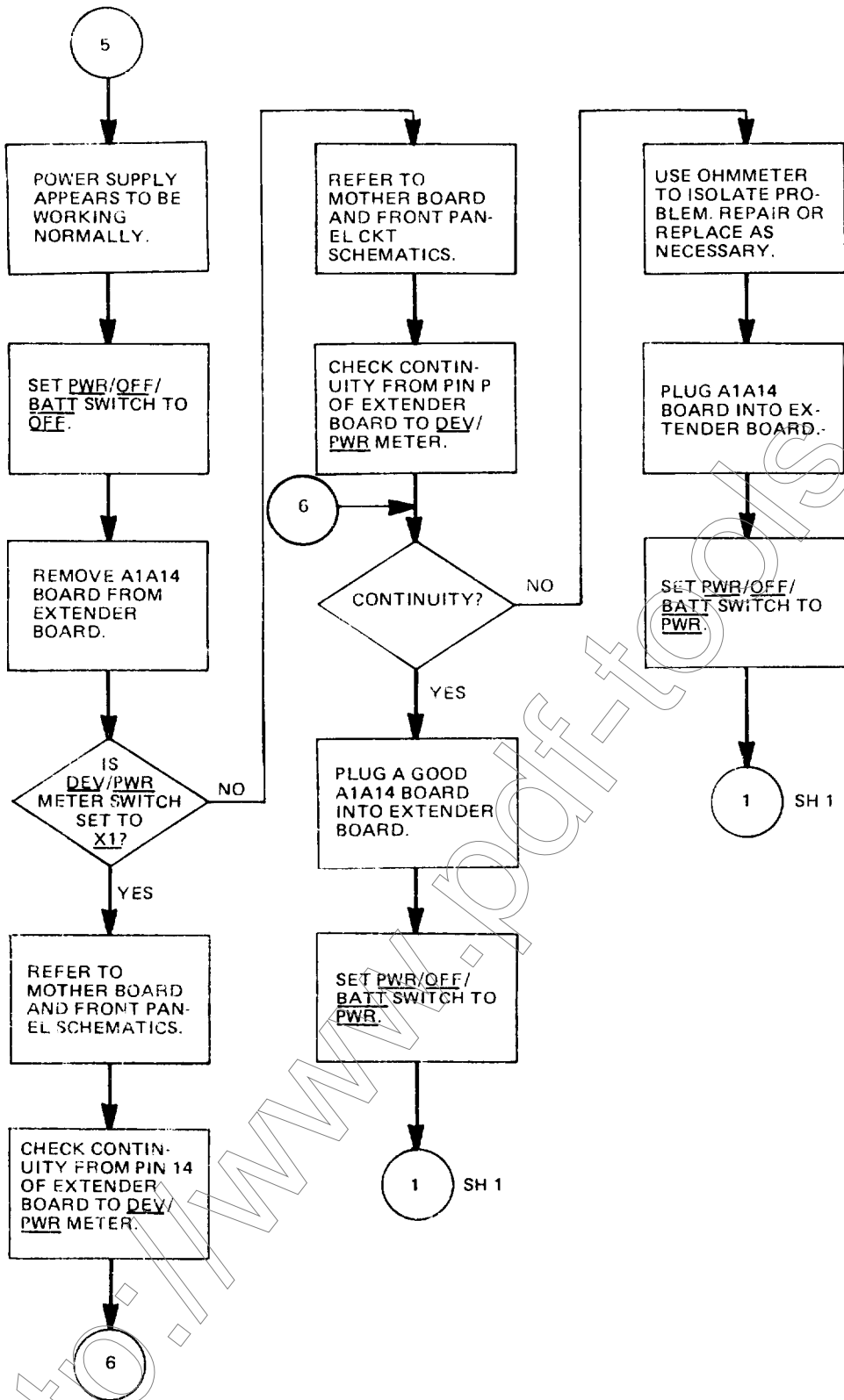


Figure 5-10. RF wattmeter troubleshooting (sheet 4 of 4)



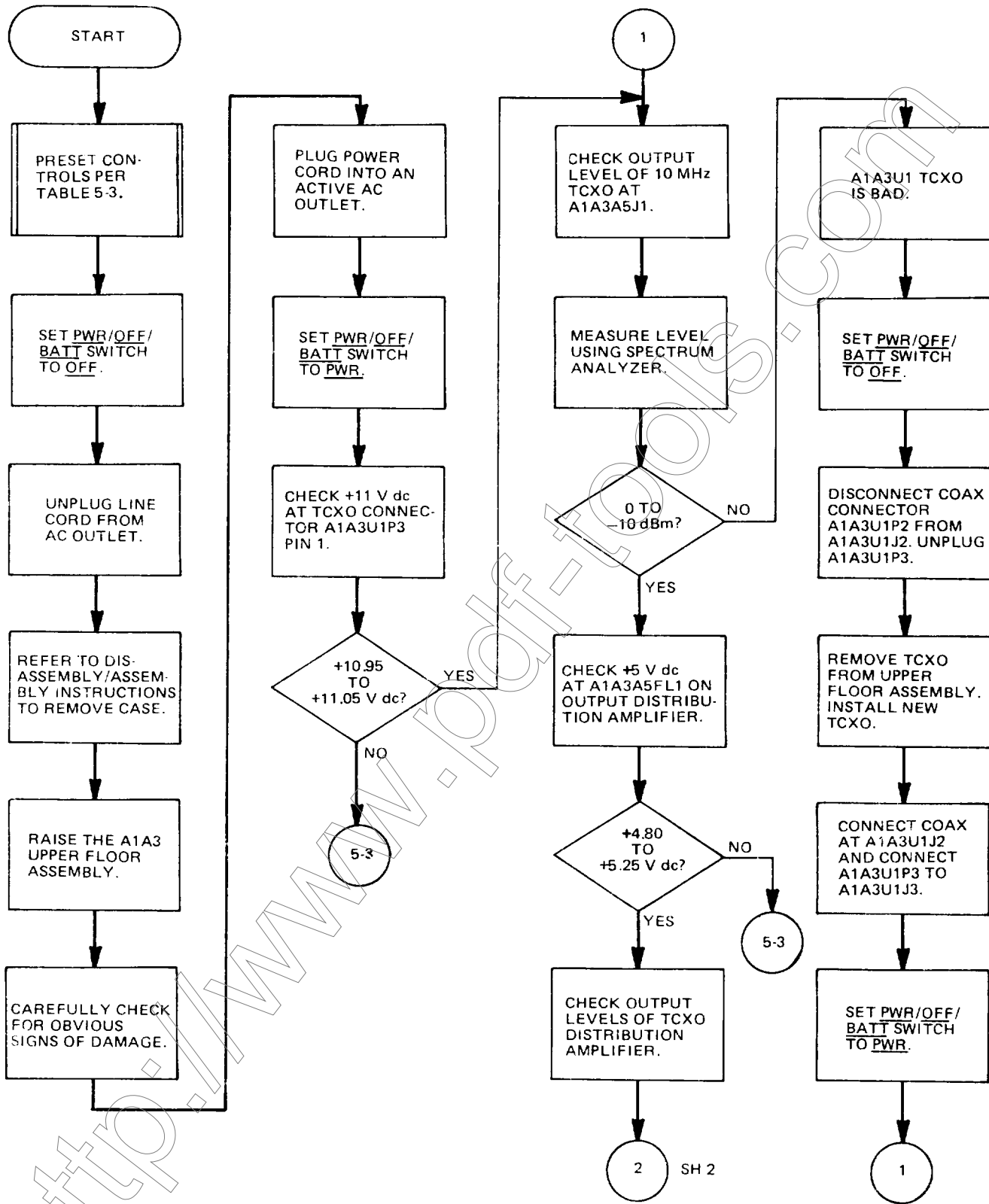


Figure 5-11. TCXO and output distribution amplifier troubleshooting (sheet 1 of 4)

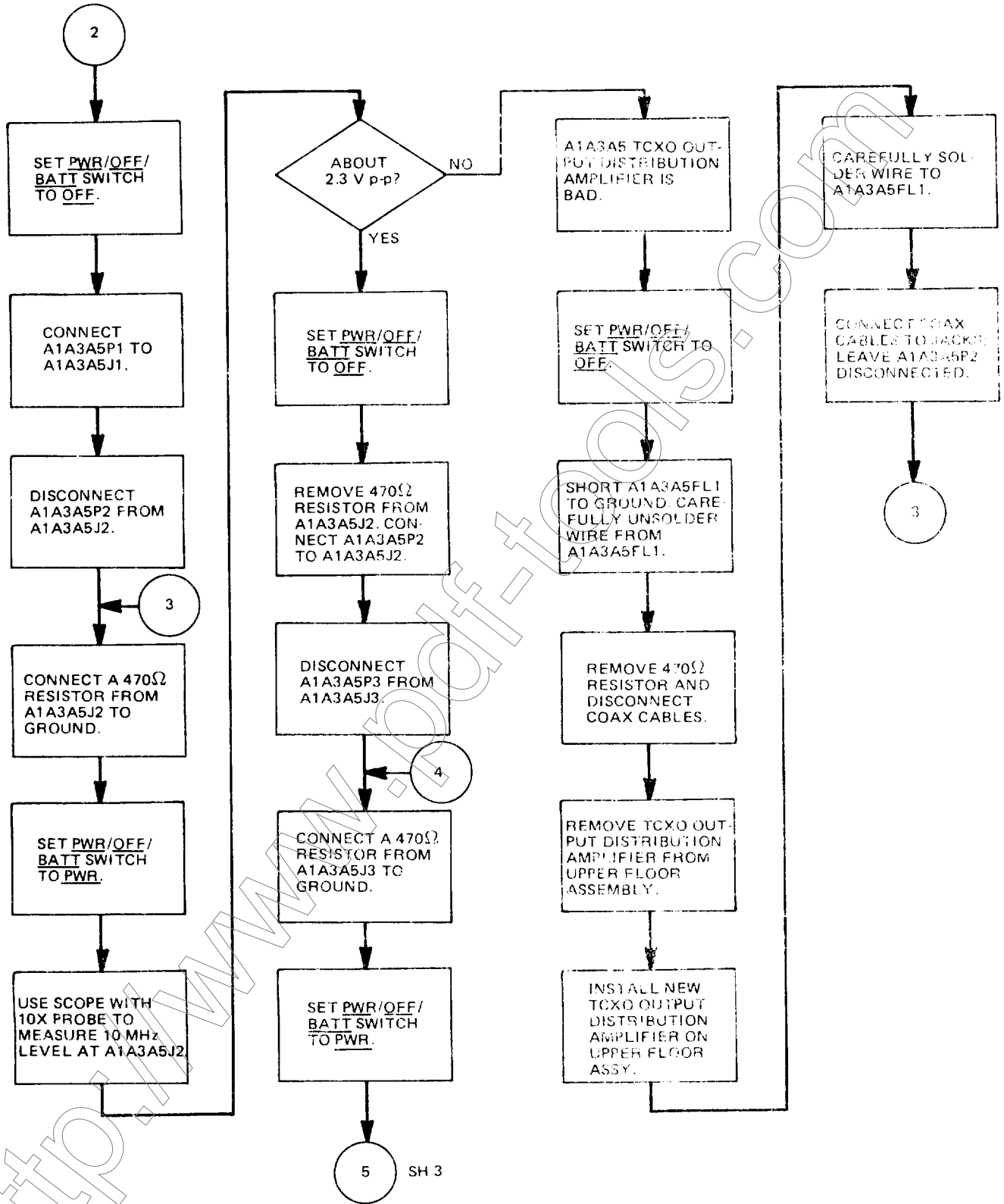


Figure 5-11. TCXO and output distribution amplifier troubleshooting (sheet 2 of 4)

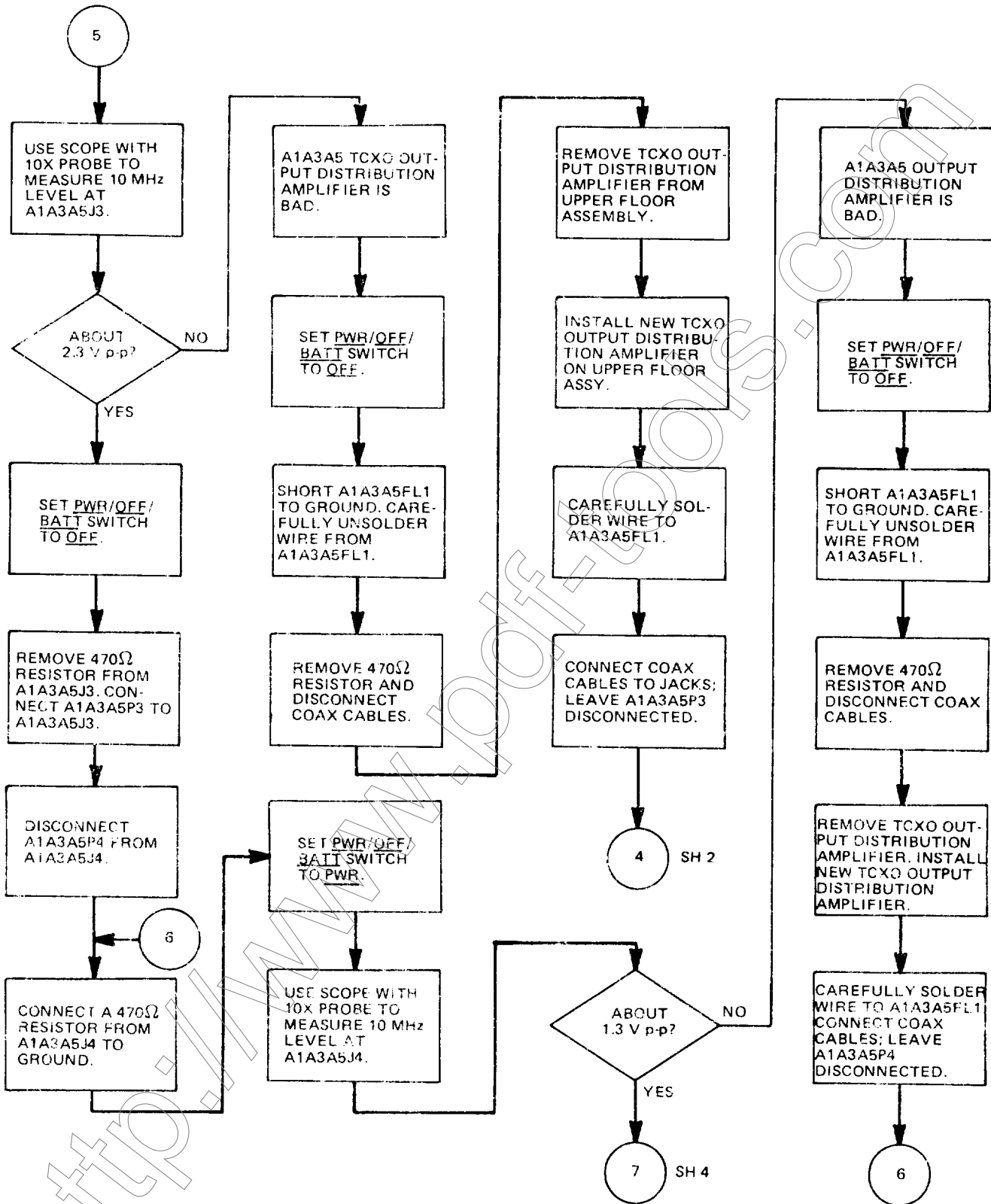


Figure 5-11. TCXO and output distribution amplifier troubleshooting (sheet 3 of 4)

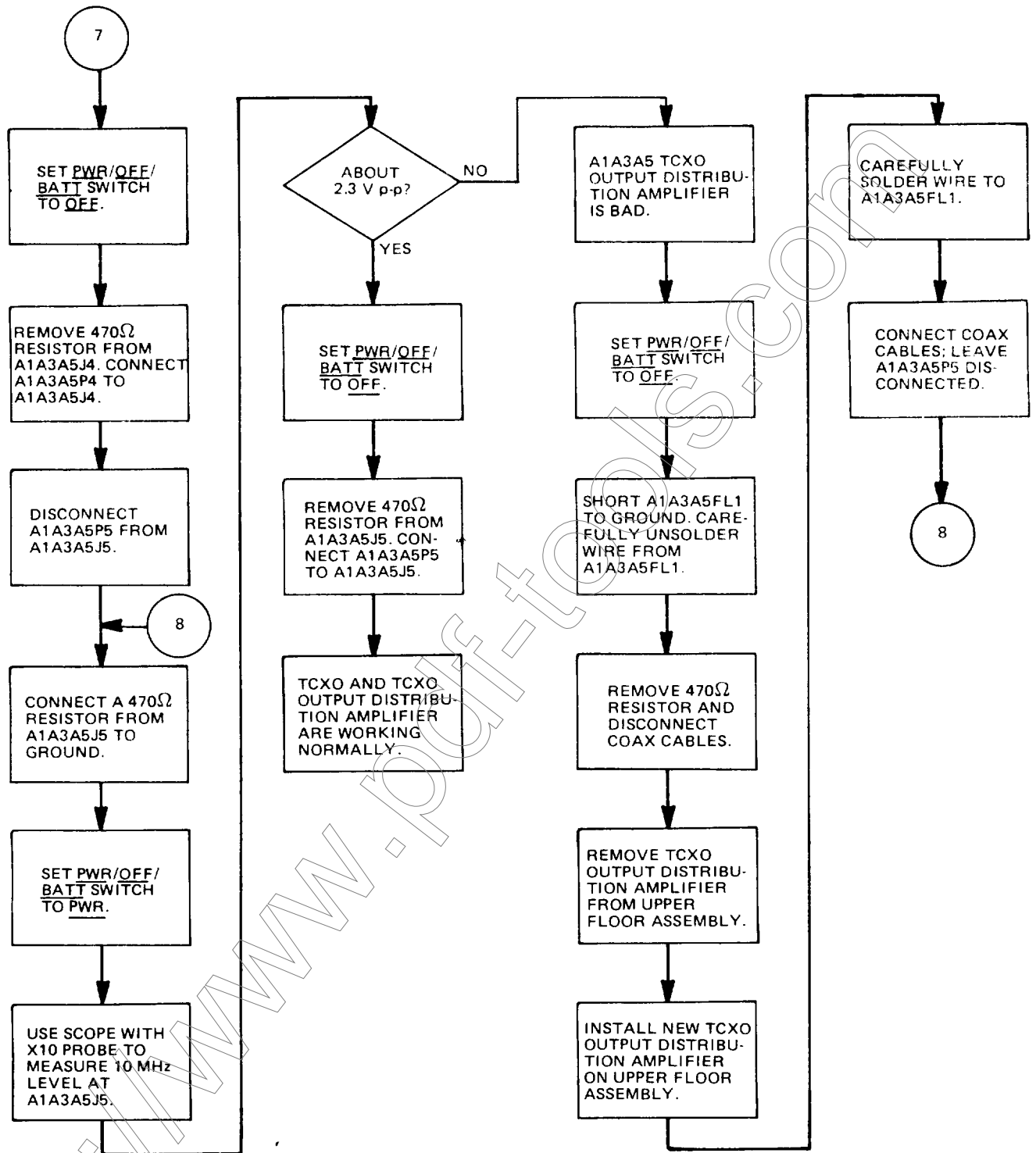


Figure 5-11. TCXO and output distribution amplifier troubleshooting (sheet 4 of 4)

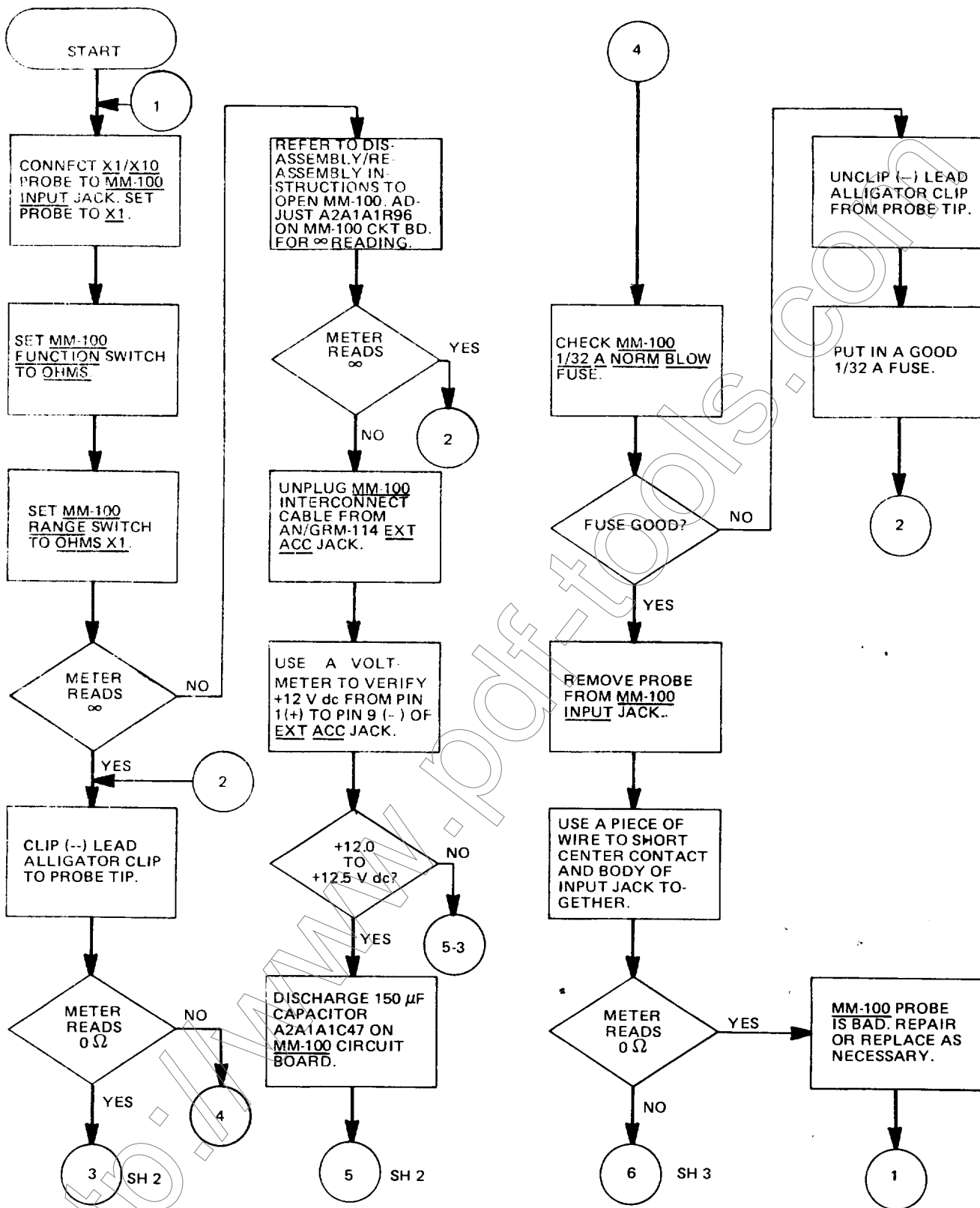


Figure 5-12. MM-100 multimeter troubleshooting (sheet 1 of 10)

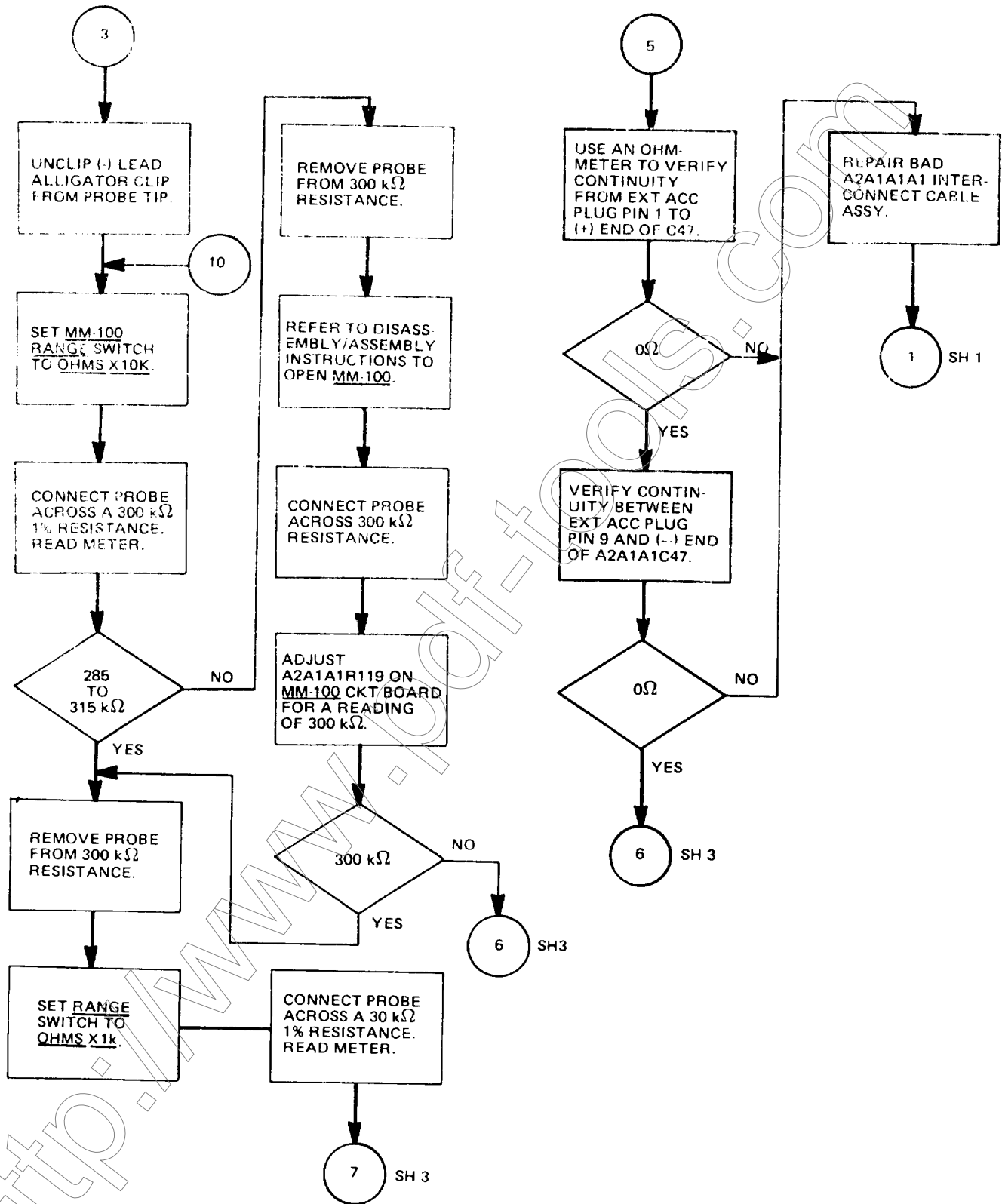


Figure 5-12. MM-100 multimeter troubleshooting (sheet 2 of 10)

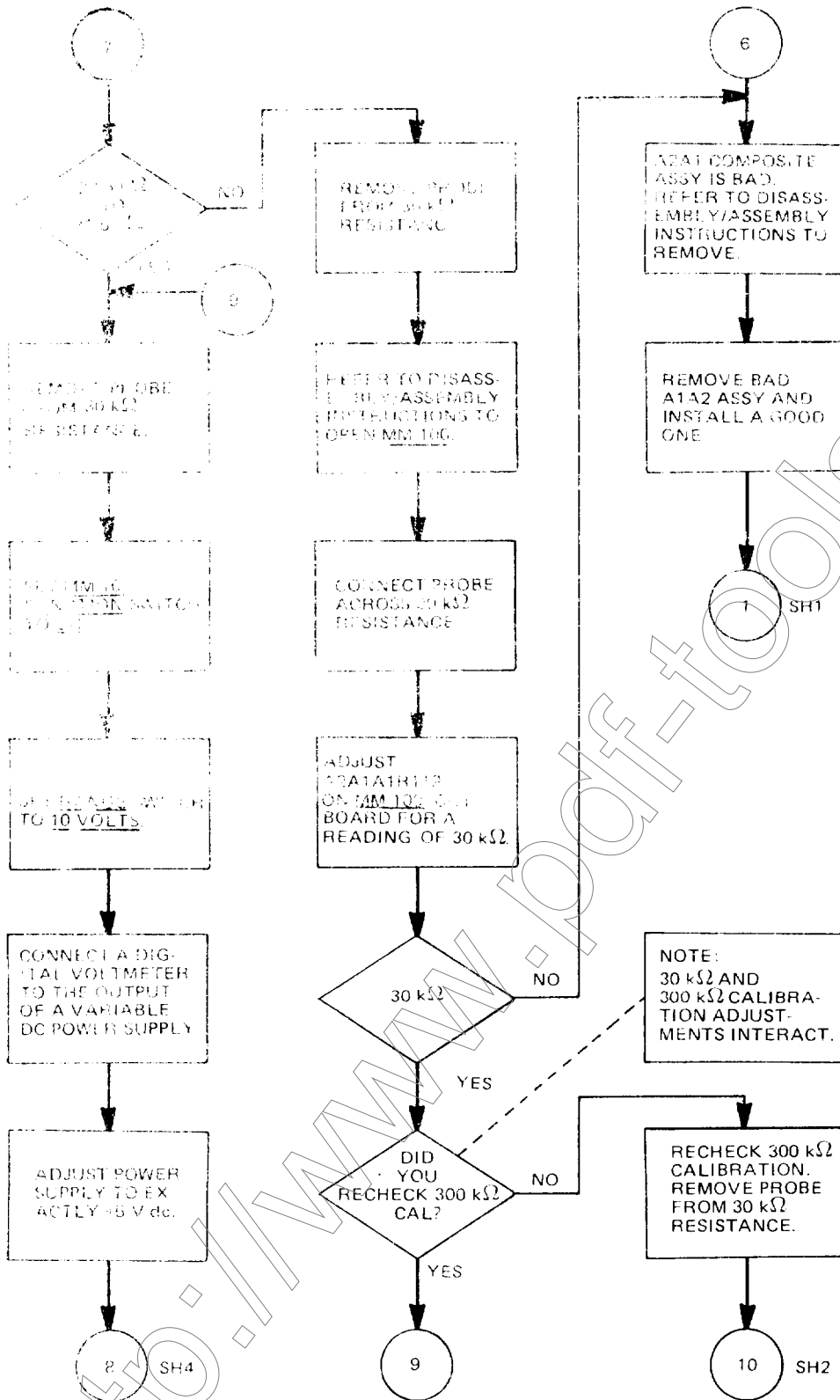


Figure 5-12. MM-100 multimeter troubleshooting (sheet 3 of 10)

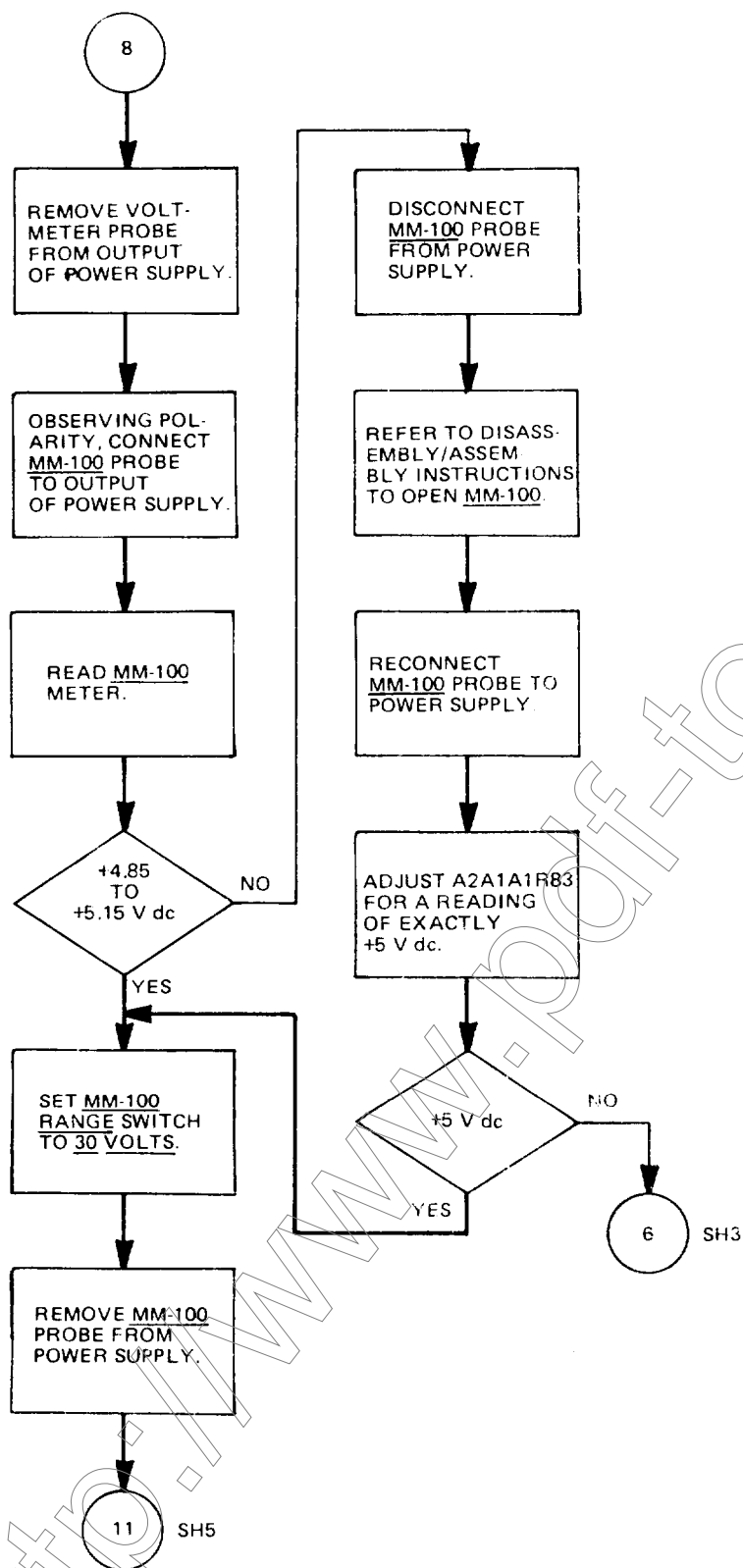


Figure 5-12. MM-100 multimeter troubleshooting (sheet 4 of 10)



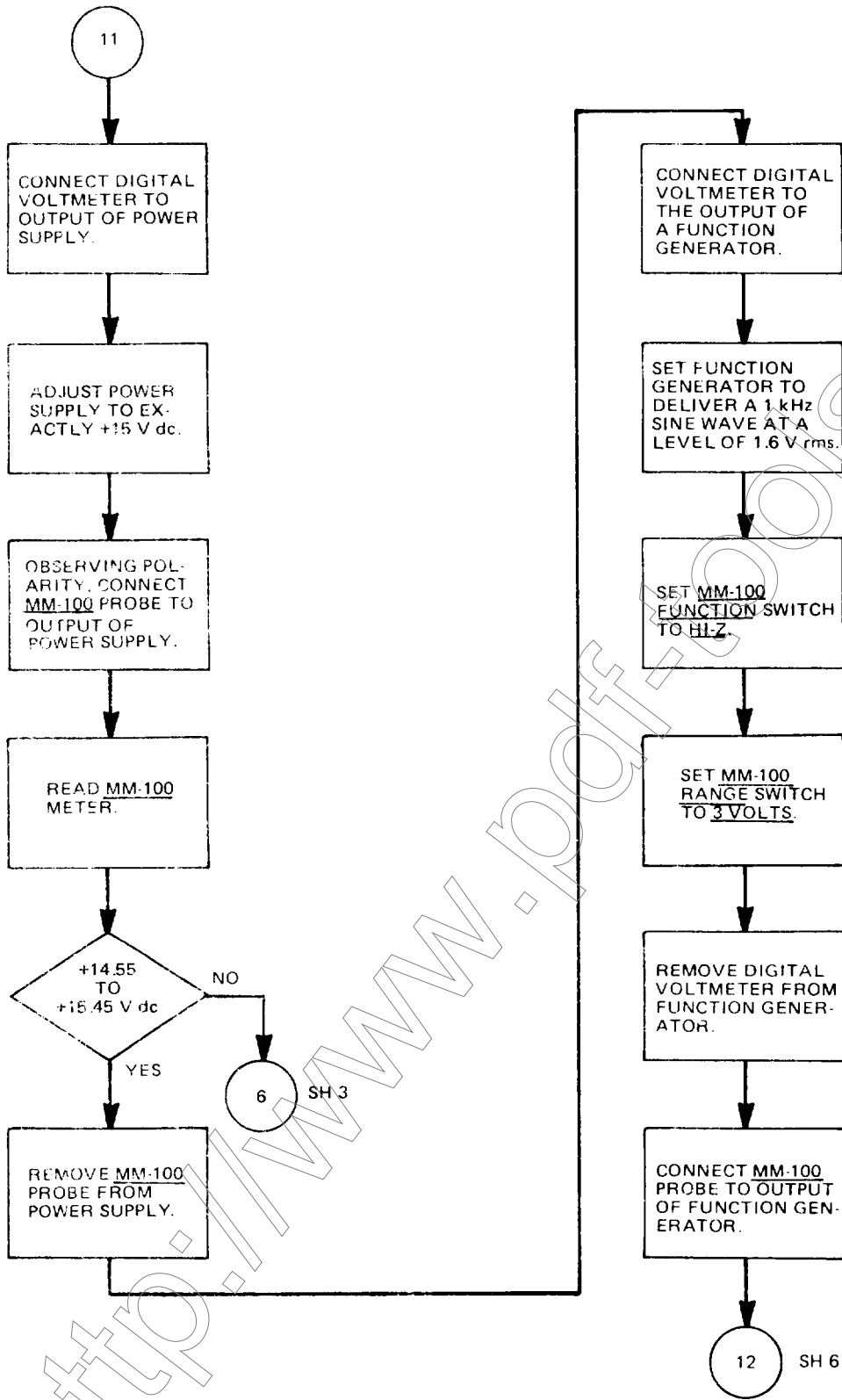


Figure 5-12. MM-100 multimeter troubleshooting (sheet 5 of 10)

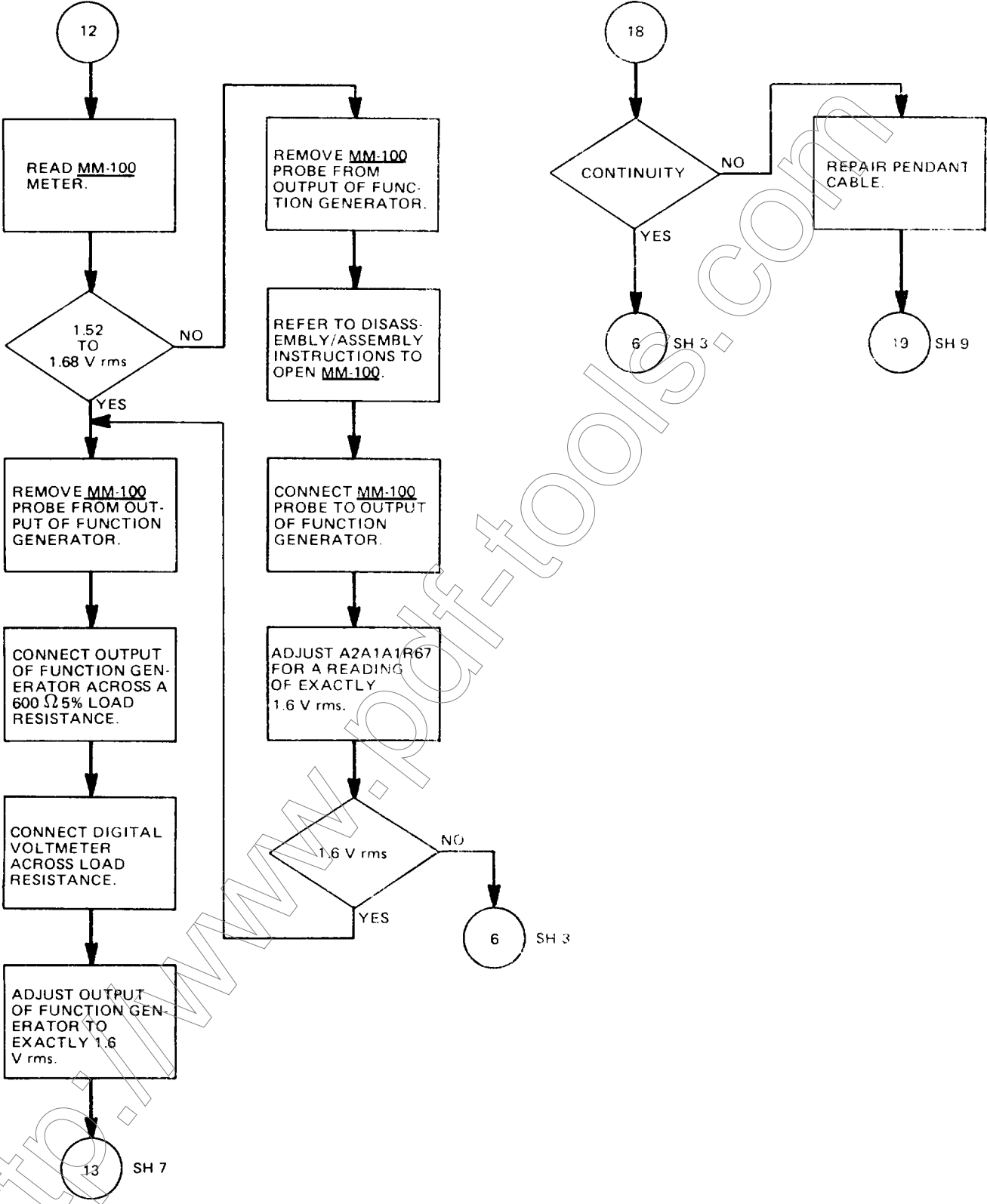


Figure 5-12. MM-100 multimeter troubleshooting (sheet 6 of 10)

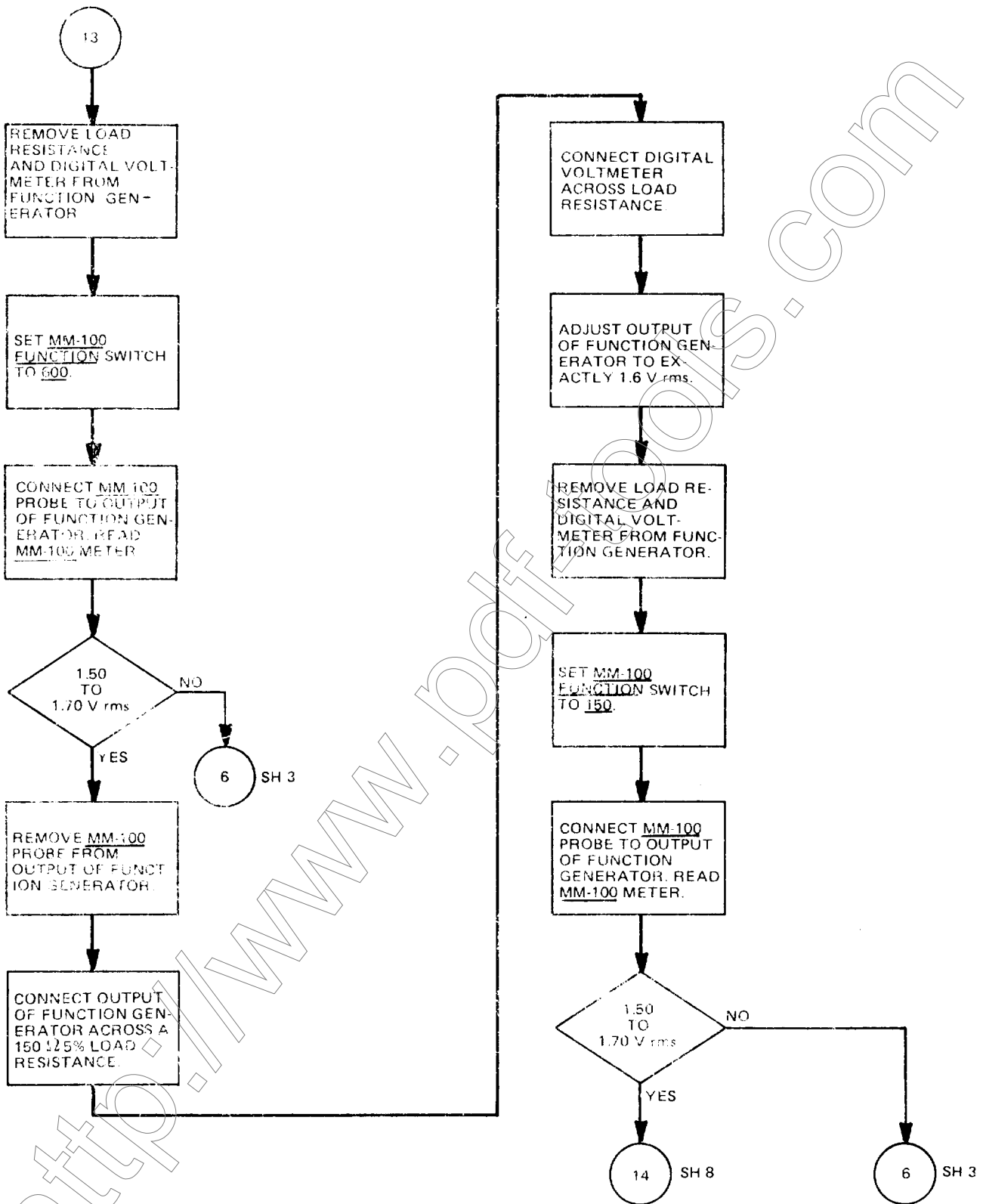


Figure 5-12. MM-100 multimeter troubleshooting (sheet 7 of 10)

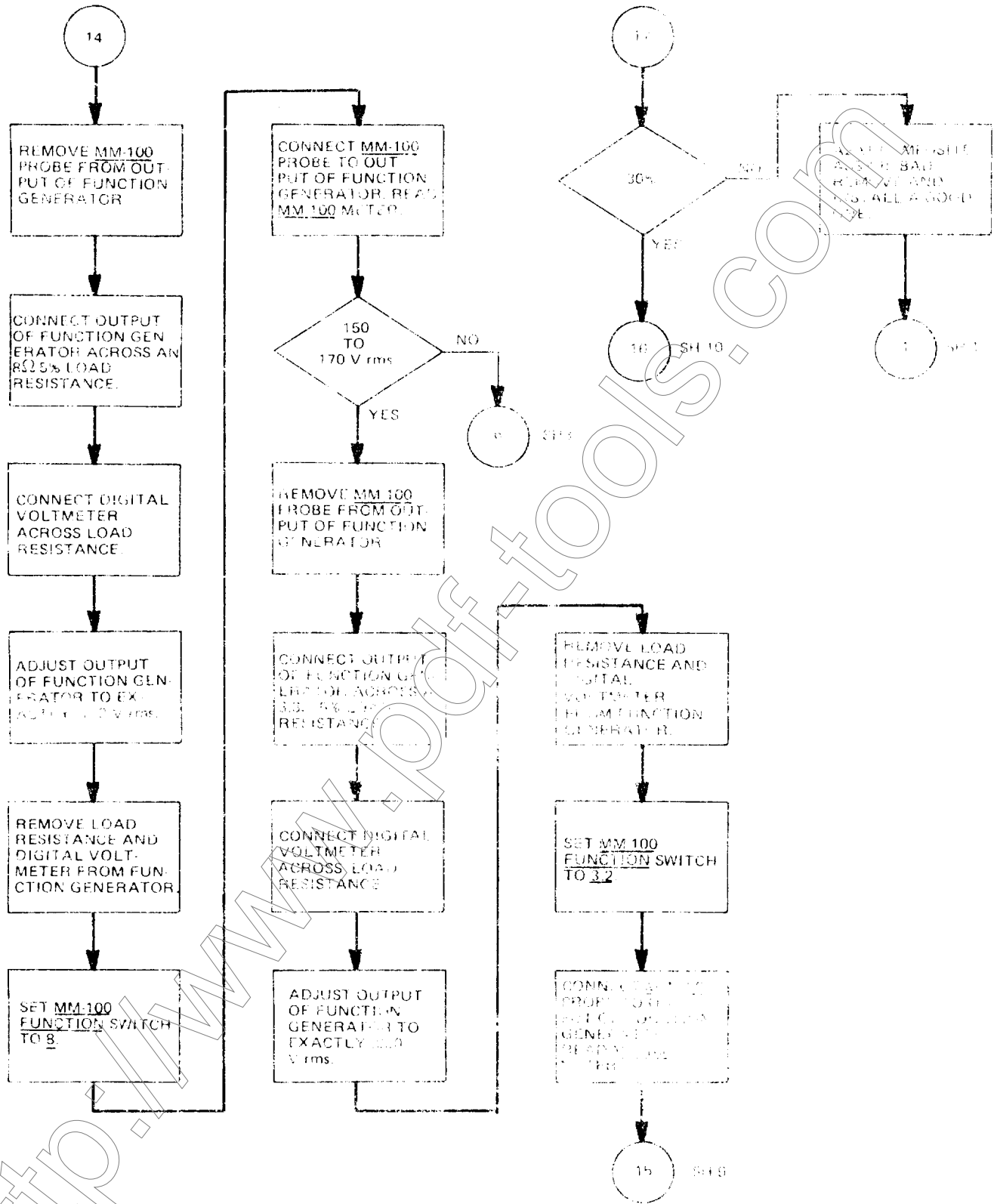


Figure 5-12. MM-100 multimeter troubleshooting (sheet 8 of 10)

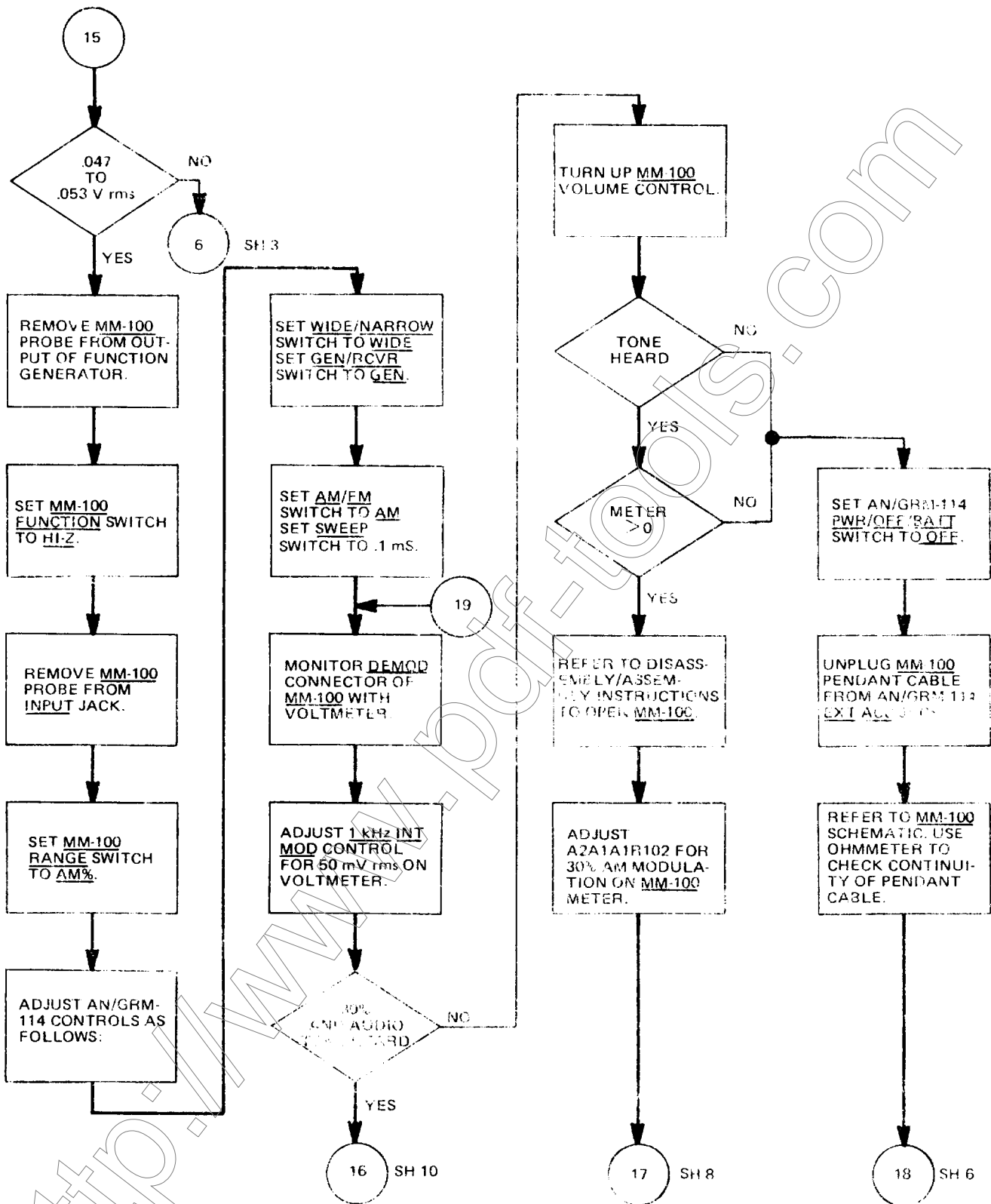


Figure 5-12. MM-100 multimeter troubleshooting (sheet 9 of 10)

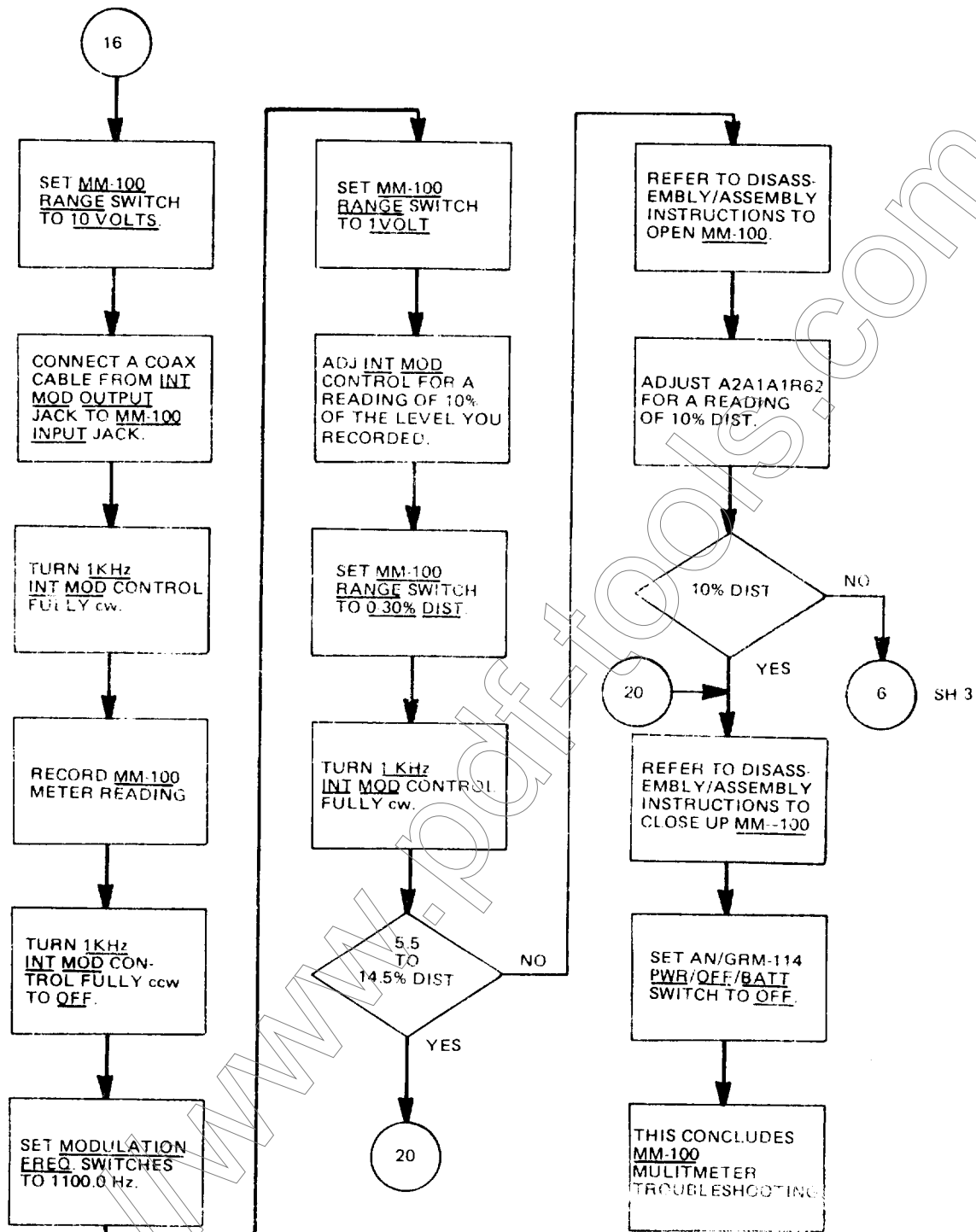


Figure 5-12. MM-100 multimeter troubleshooting (sheet 10 of 10)

5-7. AN/GRM-114 Alignment and Adjustment.

a. General. The AN/GRM-114 contains numerous assemblies which are interactive with the functioning of other assemblies. When these assemblies are replaced as part of faults found while using the performance tests or troubleshooting tests, the interactive assembly or assemblies must be aligned or adjusted. Table 5-10 is a list-

ing of assemblies which, when adjusted, aligned or replaced require that other assemblies also be aligned or adjusted. If in the performance of these alignment procedures adjustment does not achieve the required values, refer to the troubleshooting procedures of paragraph 5-6. When the required values have been achieved and the appropriate alignment procedures have been performed, return to the beginning of Figure 5-2, AN/GRM-114 Performance Test.

Table 5-10. AN/GRM-114 Assemblies and Interactive Assemblies

Assembly	Align or adjust assembly
Heterodyne Amplifier ,2 Prescaler A1A3A1	VCO Tuner A1A11
1200-2200 MHZ oscillator A1A3A2	VCX3 Tuner A1A11
A.G.C. System A1A3A3	a. VCO Tuner A1A11 b. High Frequency Multiplier/Mixer A1A26
108 MHz Bandpass Filter A1A5	1080 MHz Multiplier Amplifier A1A15
1200 MHz Amplifier A1A6	a. 250 KHz I.F. Monitor Audio A1A13 b. FM/AM Generator A1A24A3
Static Discharge Protector A1A7	250 KHz I. E'. Monitor Audio A1A13
Duty Cycle Regulator A1A8A1	Regulator and Power Supply A1A14
High Frequency Phase Lock A1A9	VCO Tuner A1A11
VCO Tuner A1A11	VCO Tuner A1A11
250 KHz I.F. Monitor Audio A1A13	250 KHz I.F. Monitor Audio A1A13
Regulator and Power supply A1A14	Regulator and Power Supply A1A14
1080 MHz Multiplier Amplifier A1A15	1080 MHz Multiplier Amplifier A1A15
1200 MHz Diode Switch A1A16	a. 230 KHz I.F. Monitor Audio A1A13 b. FM/AM Generator A1A24AS

Table 5-10. AN/GRM-114 Assemblies and Interactive Assemblies - Continued

Assembly	Align or adjust assembly
Power Monitor A1A17	Power Monitor A1A17
Spectrum Analyzer A1A18	Spectrum Analyzer A1A18
First Mixer A1A19	a. 250 KHz I.F. Monitor Audio A1A13 b. FM/AM Generator A1A24A3
Second Mixer A1A20	a. 250 KHz I.F. Monitor Audio A1A13 b. FM/AM Generator A1A24A3
100 MHz Filter A1A21	a. High Frequency Multiplier/Mixer A1A26 b. VCO Tuner A1A11
100 MHz Amplifier/ 108 MHz Mixer A1A24A1	1080 MHz Multiplier Amplifier A1A15
120 MHz Receiver A1A24A2	250 KHz I.F. Monitor Audio A1A13
FM/AM Generator A1A24A3	FM/AM Generator A1A24A3
High Frequency Multiplier/ Mixer A1A26	a. High Frequency Multiplier/Mixer A1A26 b. VCO Tuner A1A11

b. VCO Tuner A1A11 Alignment. VCO Tuner A1A11 is aligned using the following procedure:

- (1) Remove all power from the AN/GRM-114 and (disassemble the unit to gain access to the VCO Tuner A1A11 module. Then apply power to the AN/GRM-114.
- (2) Set the FREQUENCY MHz thumb-wheels to 0000000.
- (3) On 1200-2200 MHz Oscillator A1A3-A2, tag and remove plugs A1A3A2P4 and A1A3A3P1 from jack A1A3A2J4 and A1A3A3J1 respectively.
- (4) Attach plug A1A3A3P1 (removed in step (3)) to jack A1A3A2J4.

- (5) On High Frequency Phase Lock A1A9, tag and remove plug A1A9P3 from jack A1A9J3.
- (6) Attach SMB tee adapter to jack A1A9J3 on High Frequency Phase Lock A1A9.
- (7) Attach plug A1A9P3 (removed in step (5)) to the tee adapter.
- (8) Connect coaxial cable between the SMB tee adapter at A1A9J3 and the SCOPE IN connector on AN/GRM-114 front panel.
- (9) Set the oscilloscope controls for a display of 0 to 8 V dc.
- (10) On VCO Tuner A1A11 set A1A11R3 fully cw. Measure and record the dc level displayed on the oscilloscope.



Table 5-10. AN/GRM-114 Assemblies and Interactive Assemblies - Continued

Assembly	Align or adjust assembly
Power Monitor A1A17	Power Monitor A1A17
Spectrum Analyzer A1A18	Spectrum Analyzer A1208
First Mixer A1A19	a. 250 KHz I.F. Monitor Audio A1A13 b. FM/AM Generator A1A24A3
Second Mixer A1A20	a. 250 KHz I.F. Monitor Audio A1A13 b. FM/AM Generator A1A24A3
100 MHz Filter A1A21	a. High Frequency Multiplier/Mixer A1A26 b. VCO Tuner A1A11
100 MHz Amplifier/ 108 MHz Mixer A1A24A1	1080 MHz Multiplier Amplifier A1A15
120 MHz Receiver A1A24A2	250 KHz I.F. Monitor Audio A1A13
FM/AM Generator A1A24A3	FM/AM Generator A1A24A3
High Frequency Multiplier/ Mixer A1A26	a. High Frequency Multiplier/Mixer A1A26 b. VCO Tuner A1A11

b. VCO Tuner A1A11 Alignment. VCO Tuner A1A11 is aligned using the following procedure:

- (1) Remove all power from the AN/GRM-114 and disassemble the unit to gain access to the VCO Tuner A1A11 module. Then apply power to the AN/GRM-114.
- (2) Set the FREQUENCY MHz thumbwheels to 0000000.
- (3) On 1200-2200 MHz Oscillator A1A3-A2, tag and remove plugs A1A3A2P4 and A1A3A3P1 from jack A1A3A2J4 and A1A3A3J1 respectively.
- (4) Attach plug A1A3A3P1 (removed in step (3)) to jack A1A3A2J4.

- (5) On High Frequency Phase Lock A1A9, tag and remove plug A1A9P3 from jack A1A9J3.
- (6) Attach SMB tee adapter to jack A1A9J3 on High Frequency Phase Lock A1A9.
- (7) Attach plug A1A9P3 (removed in step (5)) to the tee adapter.
- (8) Connect coaxial cable between the SMB tee adapter at A1A9J3 and the SCOPE IN connector on AN/GRM-114 front panel.
- (9) Set the oscilloscope controls for a display of 0 to 8 V dc.
- (10) On VCO Tuner A1A11 set A1A11R3 fully cw. Measure and record the dc level displayed on the oscilloscope.

- (15) On 1200-2200 MHz Oscillator A1A3-A2, set A1A3A2A1R1 fully c w.
- (16) Observe the tune line on the oscilloscope while varying A1A11R3 fully through its entire range and check that the tune line does not oscillate and is centered on the center horizontal line.

## NOTE

When performing step (16), if correct skip to step ( 19); if the tune line oscillates perform steps (17) and (18); if the tune line is not centered perform step (18).

- (17) On 1200-2200 MHz Oscillator A1A3-A2, adjust A1A8A2A1R1 so that the tune line does not oscillate when varying A1A11R3 through the entire range of adjustment.
- (18) Adjust A1A11R3 so that the tune line is centered on the center horizontal line.
- (19) Disconnect the test leads from A1-A11TP1 and ground, the coaxial cable from theSMB adator and SCOPE IN connector, plug A1A9A3 from the tee adapter and the SMB tee adapter from A1A913.
- (20) Connect plugs A1A9P3, A1A3A2P4, and A1A3A3P1 to jacks A1A9J3, A1A3A2J4, and A1A3A3J1 respectively.
- (21) Remove all power from the AN/GRM-114 and reassemble.

c. High Frequency Multiplier/Mixer A1-A26 Alignment. High Frequency Multiplier/Mixer A1A26 is aligned using the following procedure:

- (1) Make sure the power cord is disconnected.
- (2) Remove fuse A1A8F3 from AN/GRM-114.

- (3) Disassemble the AN/GRM-114 to gain access to High Frequency Multiplier/Mixer A1A26 and remove the A1A26 assembly.
- (4) Connect the extender cable between jack A1A26J4 and plug A1A26P4.
- (5) Connect the AN/GRM-114 115 volt or power cord to a 115 volt ac source,
- (6) Insert the high frequency sniffer to the center of the A1A26 assembly.
- (7) Apply power to the AN/GRM-114,
- (8) Set the spectrum analyzer controls for a center frequency of 1600 MHz and a 0-dB reference and connect coaxial cable between the high-frequency sniffer and the spectrum analyzer.
- (9) Set FREQUENCY MHz thumbwheels to the frequencies listed in table 5-12 and check and record selected tune pulse frequency and amplitude as listed.
- (10) When performing step (9), if the selected tune pulse is not within tolerance, make the adjustment as listed above in table 5-12 to achieve the tolerance. Record each selected tune pulse.
- (11) Check that all selected tune pulses recorded in either step (9) or (10) are within 3 dB of one another.
- (12) When performing step (11), if any selected tune pulse is not within tolerance, adjust all selected tune pulses to achieve the 3-dB tolerance.
- (13) Turn power off, remove the power cord from its source of power, remove the high frequency sniffer from A1A26 assembly. and remove the extender from A1A26J4 and A1-A26P4.
- (14) Reinstall the A1A26 assembly in the AN/GRM-114.

Table 5-12. Tune Pulse Frequency and Amplitude Tests.

FREQUENCY					
Frequency MHz switch settings	1100	1300	1500	1700	1900
0000000	*-18 to -25 dB	Below -43 dB	Below -43 dB	Below -43 dB	Below -43 dB
2000000	Below -43 dB	*-18 to -25 dB	Below -43 dB	Below -43 dB	Below -43 dB
4000000	Below -43 dB	Below -43 dB	*-18 to -25 dB	Below -43 dB	Below -43 dB
6000000	Below -43 dB	Below -43 dB	Below -43 dB	*-18 to -25 dB	Below -43 dB
8000000	Below -43 dB	Below -43 dB	Below -43 dB	Below -43 dB	*-18 to -25 dB
ADJUSTMENT	TU5	TU4	TU3	TU2	TU1

\*Selected tune pulse

- (15) Reconnect the power cord to its power source and turn power on.
- (16) Insert the high frequency sniffer to the center of the A1A26 assembly and repeat steps (9) through (12).
- (17) Remove the high- frequency sniffer and coaxial cable, turn power off, and remove power cord from its power source.
- (18) Reassemble the AN/GRM-114 and install fuse A1A8F3.

d. 1080 MHz Multiplier Amplifier A1A15. 1080 MHz Multiplier Amplifier A1A15 is aligned using the following procedure:

- (1) Remove all power from the AN/GRM-114 and disassemble the unit to gain access to 1080 MHz Multiplier Amplifier A1A15 and Second Mixer A1A20.
- (2) Tag and remove plug A1A20P5 from jack A1A20J5 on Second Mixer A1A20 and connect to SMB jack-to-jack adaptor.
- (3) Connect coaxial cable from SMB jack-to-jack adaptor and the spectrum analyzer input.

- (4) Apply power and set spectrum analyzer controls for a center frequency of 1080 MHz and a +10 dB reference level.
- (5) Check that the spectrum analyzer displays 1080 MHz at +4 dB (or greater) and that all harmonics are at least 50 dB below the level of the 1080 MHz signal.
- (6) If the check performed in step (5) is not correct, adjust A1A15 TU1 and A1A15 TU2 (tuning screws) on the 1080 MHz cavity filter to obtain maximum amplitude of the 1080 MHz signal.
- (7) Set the PWR OFF BATT switch to OFF and then back to PWR and check that the display on the spectrum analyzer is stable with no oscillations.
- (8) If the check performed in step (7) is not correct, adjust A1A15TU1 and A1A15TU2 until the display is stable.
- (9) Turn power off, remove the coaxial cable and SMB jack-to-jack adaptor
- (10) Connect plug A1A20P5 to jack A1A20J5 on the Second Mixer.
- (11) Reassemble the AN/GRM-114.

e. 250 KHz I.F. Monitor Audio A1A13. 250 KHz I.F. Monitor Audio A1A13 is aligned, using the following procedure:

- (1) Remove all power from the AN/GRM-114 and disassemble the unit to gain access to the 250 KHz I.F. Monitor Audio A1A13 module.
- (2) Connect AN/GRM-114 115 volt ac power cord to a 115- volt ac power source and set the front panel controls as listed.

Control	Setting
GEN/RCVR	RCVR
RCVR WIDE/MID/NARROW	NARROW
FREQUENCY MHz	1202000
SQUELCH/OFF	Fully ccw to detent (not off)
INT MOD/RCVR	RCVR
AM/FM	AM
VOL	Fully ccw
1.5/5/15 KHz	15 KHz
AUTO/ZERO BATT	AUTO
EXT V/DIV	15
EXT V/DIV (vernier)	CAL
SWEEP	0.1 mS
DEV/PWR	SIG
PWR/OFF/BATT	PWR

- (3) Connect a coaxial cable between ANT INPUT jack and the ref signal generator output.
- (4) Set the rf signal generator for an output frequency of 120.2 MHz with an output level of -110 dBm and a modulation of 1 kHz at 30%.
- (5) Check that the ANT INPUT LEVEL lamp lights. If the lamp does not light, adjust A1A13R8 until the lamp just lights.
- (6) Set RCVR WIDE/MID/NARROW switch to WIDE.
- (7) Check that the ANT INPUT LEVEL lamp lights, If the lamp does not light, adjust A1A13R7 until the lamp just lights.

- (8) Set the rf signal generator for an output level of -25 dBm.
- (9) Check that the DEVIATION meter deflects full scale to the right. If the meter does not indicate full scale deflection, adjust A1A13R91 for a full-scale reading.

**NOTE**

In performing steps (5) through (9), if any adjustments were required, repeat these steps until no adjustments are required.

- (10) Set RCVR WIDE/MID/NARROW switch to NARROW; set VERT control to center the trace; the EXT V/DIV switch to 1; the AC/DC switch to DC; and connect the scope X1 probe between the SCOPE IN jack and the tie point of A1A13R25 and A1A13R26.
- (11) Check that the oscilloscope trace deflects +2 volts or less. If the trace deflection is not correct, adjust A1A13R27 for a deflection of +2 volts or less.
- (12) Set the RCVR WIDE/MID/NARROW switch to WIDE and check that the oscilloscope trace deflects -2 volts or less. If the trace deflection is not correct, adjust A1A13R27.

**NOTE**

In performing steps (11) and (12), if any adjustments were required, repeat these steps until no adjustments are required.

- (13) Remove the scope X1 probe.
- (14) Set the RCVR WIDE/MID/NARROW switch to NARROW; the AM/FM switch to FM; the 1.5/5/15 KHz switch to 1.5; the SQUELCH control fully cw; and the FREQUENCY MHz thumbwheels to 000 100 0.

- (15) Check that the **FREQ. ERROR (KHz)** meter indicates 0. If the meter is not correct, adjust A1A13R47 for the 0 indication.
- (16) Set the **SQUELCH** control fully ccw (into detent-off); the **EXT V/DIV** switch to 15; the **FREQUENCY MHz** thumbwheels to 000 000 0; the **VERT** control to center the oscilloscope trace on the center horizontal line; and the 1.5/5/15 KHz switch to 15.
- (17) Set the **FREQUENCY MHz** thumbwheels to 0000100.
- (18) Check that the **FREQ. ERROR (KHz)** meter and the oscilloscope indicate  $-10 \pm 0.5$  kHz. If the **FREQ. ERROR (KHz)** meter indication is not correct, adjust A1A13R39 for a reading of  $-10 \pm 0.5$  kHz. If the oscilloscope indication is not correct, adjust A1A13R44 for a trace that is  $-10 \pm 0.5$  kHz.
- (19) Set 1.5/5/15 KHz switch to 5; set **EXT V/DIV** switch to 5; and adjust the **VERT** control to center the oscilloscope trace on the center horizontal line.
- (20) Set **FREQUENCY MHz** thumbwheels to 0000050. Check that the **FREQ. ERROR (KHz)** meter and the oscilloscope indicate  $-5 \pm 0.2$  kHz. If the **FREQ. ERROR (KHz)** meter indication is not correct, adjust A1A13R41 for a reading of  $-5 \pm 0.2$  kHz. If the oscilloscope indication is not correct, adjust A1A13R44 for a trace that is  $-5 \pm 0.2$  kHz.
- (21) Set 1.5/5/15 KHz switch to 1.5; set **EXT V/DIV** switch to 1.5; and adjust the **VERT** control to center the oscilloscope trace on the center horizontal line.
- (22) Set **FREQUENCY MHz** thumbwheels to 000 001 0. Check that the **FREQ. ERROR (KHz)** meter and oscilloscope indicate  $-1 \pm 0.1$  kHz. If the **FREQ. ERROR (KHz)** meter indication is not correct, adjust A1A13R42 for a reading of  $-1 \pm 0.1$  kHz. If the oscilloscope indication is not correct, adjust A1A13R44 for a trace that is  $-1 \pm 0$  kHz.
- (23) Set **FREQUENCY MHz** thumbwheels to 0000000 and set the **GEN/RCVR** switch to **GEN**.
- (24) Check that the **FREQ. ERROR (KHz)** meter indicates 0. If the **FREQ. ERROR (KHz)** meter indication is not correct, adjust the **ZERO/RCVR** screwdriver adjustment for 0.
- (25) Set the **GEN/RCVR** switch to **RCVR**; set **DEV/PWR** switch to 2 KHz; and set the **AUTO/ZERO BATT** switch to **AUTO**.
- (26) Check that the **DEVIATION (KHz)** meter indicates 0. If the **DEVIATION (KHz)** meter indication is not correct, adjust A1A12R71 for a reading of 0.
- (27) Set the **GEN/RCVR** switch to **GEN** and check that the **DEVIATION (KHz)** meter indicates 0. If the **DEVIATION (KHz)** meter indication is not correct, adjust A1A13R81 for a reading of 0.
- (28) Connect the coaxial cable between the **TRANS/RCVR** jack and an external modulation meter; set the **FREQUENCY MHz** thumbwheels to 120000 0; set the **EXT V/DIV** switch to 15 KHz; set **RCVR WIDE/MID/NARROW** switch to **WIDE**; set the **HI LVL/NORM** switch to **HI LVL**; and set the **DEV/PWR** switch to 20 KHz.

NOTE

When performing step (29), if necessary to obtain an indication 0:1 the modulation meter, adjust the **RF LEVEL/BFO INJECTION** dial.

- (29) Set 1 KHz INT MOD control for a 10 kHz indication on the external modulation meter.
- (30) Check that the DEVIATION (KHz) meter indicates  $10 \pm 0.1$  kHz. If the DEVIATION (KHz) meter indication is not correct, adjust A1A13R79 for a reading of  $10 \pm 0.1$  kHz.
- (31) Set the 1 KHz INT MOD control for a 4 kHz indication on the modulation meter; set the RCVR WIDE/MID/NARROW switch to NARROW; set the EXT V/DIV switch to 6 KHz; and set the DEV/PWR switch to 6 KHz.
- (32) Check that the DEVIATION (KHz) meter indicates  $4 \pm 1$  kHz. If the DEVIATION (KHz) meter indication is not correct, adjust A1A13R83 for a reading of  $4 \pm 1$  kHz.
- (33) Set 1 KHz INT MOD control for a 1 kHz indication on the modulation meter; set the EXT V/DIV switch to 1.5 KHz; and set the DEV/PWR switch to 2 KHz.
- (34) Verify that the DEVIATION (KHz) meter indicates  $1 \pm 0.05$  kHz. If the DEVIATION (KHz) meter indication is not correct, adjust A1A13R85 for a reading of  $1 \pm 0.05$  kHz.
- (35) Disconnect the external modulation meter and coaxial cable.
- (36) Connect the coaxial cable between the MM-100 DE-MOD jack and the digital multimeter: connect the MiU-100 cable to the EXT ACC jack on the AN/GRM-114; set the GEN/RCVR switch to RCVR; set AM/FM switch to AM; and connect a coaxial cable between the ANT INPUT jack and the rf signal generator Output.
- (37) Adjust the rf signal generator for a 120 MHz output with a level of -60 dBm and modulation of 1 kHz at 30%.

(38) Verify that the digital multimeter indicates 50 millivolts. If the digital multimeter indication is not correct, adjust A1A13R115 for a multimeter indication of 50 millivolts.

(39) Remove all cables and test equipment, turn off power, remove Power Cord from Power Source and reassemble the AN/GRM-114.

f. FM/AM Generator A1A24A3. FM/AM Generator A1A24A3 is aligned using the following procedure:

(1) Remove all power from the AN/GRM-114 and disassemble the unit to gain access to the FM/AM Generator A1A24A3 module.

(2) Remove the metal shield from the FM/AM Generator mechanical assembly A1A24A3, then connect the digital voltmeter between the tie point of R24 and R25 on circuit A1A24A3A1.

(3) Connect the AN/GRM-114 Power cord to power source and set the front panel controls as listed:

Control	Setting
GEN/RCVR	GEN
RCVR WIDE/MID/NARROW	NARROW
AC/DC	DC
AM/FM	AM
SWEEP	10 $\mu$ S
INT MOD	OFF
1 KHz INT MOD	OFF
EXT V/DIV	15 KHz
DEV/PWR	SIG
BFO OFF	BFO
1.5/5/15 KHz	5 KHz

(4) Adjust A1A24A3L2 through its entire range cw and then fully ccw and check that the digital voltmeter indicates 1 to 10 volts dc.

(5) Adjust A1A24A3L2 for an indication of  $5 \pm 0.5$  volts dc on the digital voltmeter and check that the 250 kHz signal displayed on the oscilloscope is stable.

NOTE

If the indications measured in steps (4) and (5) are not correct, replace FM/AM Generator A1A24A3 and repeat steps (3) through (5) before proceeding.

- (6) Remove the digital voltmeter; remove from AN/GRM-114; reassemble metal shield to FM/AM Generator A1A24A3; reapply power to AN/GRM-114; set the FREQUENCY MHz thumbwheels to 120 051 0; set the RF LEVEL/BFO INJECTION control to  $-100$  dB; set the HI LVL/NORM switch to  $100 \mu\text{V}$ ; and connect the coaxial cable between the TRANS/RCVR jack and the spectrum analyzer input.
- (7) Check that the spectrum analyzer displays a 120.051 MHz signal at  $60 \pm 1$  dB. If the spectrum analyzer display is not correct, adjust A1A24A3-R20 for a display of 120.051 MHz at  $60 \pm 1$  dB.
- (8) Set the GEN/RCVR switch to RCVR; set the RF LEVEL/BFO INJECTION control to 1; set the SWEEP switch to 10 mS; and connect the coaxial cable between the ANT INPUT jack and the rf signal generator output jack.
- (9) Adjust the rf signal generator for a 120.05 MHz output with an output level of 100 microvolts.
- (10) Check that the oscilloscope display is as shown in figure 5-13, and the FREQ. ERROR indicates full scale deflection to the left. If the oscilloscope display and the FREQ. ERROR indication are not correct, adjust A1A24A3R21 for the proper indications.

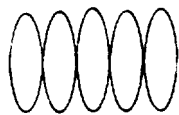


Figure 5-13. Zero beat pattern

- (11) Remove all cables and turn off power, unplug power cord and reassemble the AN/GRM-114.

g. Regulator and Power Supply A1A14. Regulator and Power Supply A1A14 is aligned using the following procedures:

- (1) Remove all power from the AN/GRM-114 and disassemble the AN/GRM-114 to gain access to the Regulator and Power Supply A1A14 module.
- (2) Connect the AN/GRM-114 power cord to power source.
- (3) Set the PWR OFF BATT switch to PWR and connect the digital voltmeter between pin 5 of A1A14P1 and ground.
- (4) Verify that the digital voltmeter indicates 10.95 to 11.05 volts dc. If the digital voltmeter indication is not correct, adjust A1A14R24 for a reading 11.00 volts dc.
- (5) Connect the digital voltmeter between pin 9 of A1A14P1 and ground and check for an indication of  $-34.5$  to  $-35.4$  volts dc. If the digital voltmeter indication is not correct, replace Regulator and Power Supply A1A14.
- (6) Connect the digital voltmeter between pin 15 of A1A14P1 and ground and check for an indication of  $-10.5$  to  $-13.5$  volts dc. If the digital voltmeter indication is not correct, replace Regulator and Power Supply A1A14.
- (7) Set the PWR OFF BATT switch to OFF; remove the AN/GRM-114 power cord from power source, and disconnect the internal battery.
- (8) Observe the polarity and connect the dc power supply to the AN/GRM-114 battery leads.
- (9) Connect the digital voltmeter to the dc power supply output and adjust

the dc power supply for a 14 volt dc output as indicated on the digital voltmeter.

- (10) Set the PWR OFF BATT switch to BATT.
- (11) Observe the digital voltmeter and adjust the dc power supply to decrease the output voltage and check that the AN/GRM-114 power cuts off when the digital voltmeter indicates between 10.8 and 11.2 volts dc. If the AN/GRM-114 power does not cutoff correctly, adjust A1A14R14 until the proper cutoff voltage level is achieved.
- (12) Repeat steps (9) through (11) until no adjustment is required to achieve proper cutoff voltage.
- (13) Adjust the dc power supply for a 14 volt dc output. as indicated on the digital voltmeter and set PWR OFF BATT to BATT and depress twice.
- (14) Hold the AUTO/ZERO BATT switch in the ZERO BATT position and check that the DEVIATION (KHz) meter indicates 14 on the 0 to 20 Scale. If the DEVIATION (KHz) meter indication is not correct, adjust A1A14R28 for an indication of 14.
- (15) Disconnect DC Power Supply and reconnect internal battery.
- (16) Turn off all power, remove all cables and test instruments, and reassemble the AN/GRM-114.

h. Power Monitor A1A17. Power Monitor A1A17 is aligned using the following procedure:

- (1) Remove all power from the AN/GRM-114 and disassemble the AN/GRM-114 to gain access to the Regulator and Power Supply A1A14 module.
- (2) Obtain an rf power source capable of providing 50 watts of power and record the type of modulation, the deviation, and frequency of the rf power source.

- (3) Set the AN/GRM-114 controls as listed:

Control	Setting
DEV/PWR	X1 WATTS
GEN/RCVR	GEN
AM/FM	As recorded in step b.
RCVR WIDE/MID/NARROW	a) If deviation recorded in step b. is 0 to 9 kHz - NARROW b) If deviation recorded in step b. is <9- WIDE
AUTO/ZERO BATT	AUTO
AC/DC	DC
FREQUENCY MHz	As recorded in step h.

**CAUTION**

Connect the OUTPUT of the 10 dB pad to ONLY the TRANS/RCVR jack. Connection to any other jack will cause severe damage to the AN/GRM-114.

- (4) Connect a coaxial cable between the rf power source and the INPUT of the 10 dB pad and a coaxial cable between the OUTPUT of the 10 dB pad and the AN/GRM-114 TRANS/RCVR jack.
- (5) Turn on or key the 50 watt rf power source and check for an indication of 5 watts on the DEVIATION (KHz) meter. If the indication 011 the DEVIATION (KHz) meter is not correct, adjust A1A14R36 for a 5 watt indication.
- (6) Turn off or unkey the 50 watt rf power source; set the DEV/PWR switch to X10 WATTS; and remove the coaxial cables and the 10 dB pad.
- (7) Connect the coaxial cable between the output of the 50 watt rf power source



and the TRANS/RCVR jack on the AN/GRM-114.

- (8) Turn on or key the 50 watt rf power source and check that the DEVIATION (KHz) meter indicates 5. If the DEVIATION (KHz) indication is not correct, adjust A1A14R34 for 5 on the meter.
- (9) Turn off all power, remove all cables and test instruments and reassemble the AN/GRM-114.

i. Spectrum Analyzer A1A18. Spectrum Analyzer A1A18 is aligned using the following procedure.

- (1) Remove all power from the AN/GRM-114 and disassemble the unit to gain access to the Spectrum Analyzer A1A18 module.
- (2) Connect the AN/GRM-114 power cord to a power source and set the front panel controls as listed:

Control	Setting
MODULATION FREQ Hz	1000.0
INT MOD	Midrange
GEN/RCVR	GEN
ANALY DISPR	Fully ccw to off.
EXT V/DIV	15 KHz
SWEEP	1 mS
PWR/OFF/BATT	PWR
VERT and HORIZ	Center signal on CRT.
FOCUS and INTENSITY	Clean and sharp display on CRT
AM/FM	FM
SWEEP vernier	Fully cw to CAL

- (3) Set HORIZ control so that the first cycle is aligned with the first major division on the left of the CRT.
- (4) Verify that 9 cycles appear on the CRT. If 9 cycles are not displayed, adjust A1A18A4R40 for the correct display.

- (5) Set HORIZ control so that the fifth cycle is on the center graticule of the CRT.
- (6) Verify that each cycle is aligned with the major divisions  $\pm 1$  minor division of the CRT graticule. If all cycles are not aligned, adjust A1A18A4R47 for the correct alignment.
- (7) Set the EXT V/DIV switch to 1.5 KHz.
- (8) Set the INT MOD control for 1 major division and verify that the displayed signal remains synchronized. If the signal is not synchronized, adjust A1A18A4R40 to synchronize the signal.
- (9) Observe the amplitude of the displayed signal and set the EXT V/DIV vernier control fully ccw.
- (10) Verify that the signal displayed decreases to approximately 1/10 of the observed amplitude and stays synchronized. If the displayed signal is not correct, adjust A1A18A4R40 to obtain the synchronized signal desired.
- (11) Set the EXT V/DIV Vernier control fully cw to CAL, the AM/FM switch to AM, and vary the INT MOD/OFF control to produce an AM signal envelope with 0 to 10% modulation.
- (12) Verify that the signal displayed stays synchronized. If the signal does not remain synchronized, adjust A1A18-A4R40 to obtain synchronization.
- (13) Set the SWEEP switch to 0.1 mS.
- (14) While adjusting the SWEEP vernier control ccw, verify that the signal displayed stays synchronized. If the signal does not stay synchronized, adjust A1A18A4R40 to keep the signal synchronized.

- (15) Set SWEEP Vernier control fully cw to CAL.
- (16) Repeat steps (3) through (15) until no adjustments are required.
- (17) Attach a BNC tee adapter to the SCOPE IN connector on the front panel.
- (18) Connect a coaxial cable between the INT MOD OUT connector and one side of the BNC tee.
- (19) Connect a coaxial cable between the remaining side of the BNC tee and the vertical input of an external oscilloscope.
- (20) Set the EXT V/DIV switch to .1 KHz and the SWEEP switch to 1 mS.
- (21) Set the external oscilloscope for 0.1 volts per division, 1 millisecond per division horizontal sweep, and adjust the AN/GRM-114 INT MOD control for a four major division signal on the external oscilloscope.
- (22) Verify that the AN/GRM-114 CRT indicates a 4 major division  $\pm 1$  minor division signal display. If the signal displayed is not correct, adjust A1A18A4R7 for the correct indication.
- (23) Set the external oscilloscope for 0.01 volt per division, the AN/GRM-114 EXT V/DIV switch to .01, and the INT MOD control for a four major division signal on the external oscilloscope.
- (24) Verify that the AN/GRM-114 CRT indicates a 4 major division  $\pm 1$  minor division signal display. If the signal displayed is not correct, adjust A1A18A4R7 for the correct indication.
- (25) Set the external oscilloscope for 1 volt per division, the AN/GRM-114 EXT V/DIV switch to 1, and the INT MOD control for a four major division signal on the external oscilloscope.
- (26) Check that the AN/GRM-114 CRT indicates a 4 major division  $\pm 1$  minor division signal display. If the signal displayed is not correct, adjust A1A18A4R7 for the correct indication.
- (27) Set the external oscilloscope for 10 volts per division, the AN/GRM-114 EXT V/DIV switch to 10, and the INT MOD control for a 1 major division signal on the external oscilloscope.
- (28) Check that the AN/GRM-114 CRT indicates a 1 major division  $\pm 1$  minor division signal display. If the signal displayed is not correct, adjust A1A18A4R7 for the correct indication.
- (29) Repeat steps (20) through (28) until no adjustments are required.
- (30) Disconnect and remove the external oscilloscope, coaxial cables, and the BNC tee adapter.
- (31) Set the ANALY DISP control cw just out of detent and the FREQUENCY MHz thumbwheels to 125 500 0.
- (32) On the Dual Tone Generator A1A12 module disconnect A1A12J1 from A1A12P1.
- (33) Remove all power from the AN/GRM-114, then remove the Spectrum Analyzer Assembly A1A18 from the Front Panel to gain access to Spectrum Analyzer Module No. 2 A1A18-A3. Then reapply power to the AN/GRM-114.
- (34) Obtain an rf signal generator anti set for a frequency of 125.500 with an rf output level of  $-90$  dBm and connect a coaxial cable from the ANT INPUT connector to the signal generator output .
- (35) Verify that the baseline on the CRT display is  $-109$  dBm  $\pm 1$  dB. If the baseline is not correct, adjust A1A1-A3R30 for the correct baseline display.

- (36) Verify that the signal displayed on the CRT is  $-90$  dBm  $\pm 1$  dB. If the signal displayed is not correct, adjust A1-A18A3R4 for the correct signal display.
- (37) Set the signal generator for an rf output of  $+60$  dBm.
- (38) Check that the signal displayed on the CRT is  $-60$  dBm  $\pm 1$  dB. If the signal displayed is not correct, adjust A1-A18A3R29 for the correct signal display.
- (39) Repeat steps (34) through (38) until no adjustments are required,
- (40) Set the signal generator for an rf output of  $-30$  dBm.
- (41) Verify that the signal displayed on the CRT is  $-30$  dBm  $\pm 1$  dB. If the signal displayed is not correct, adjust A1A18-A3R5 for the correct signal display.
- (42) Remove all power from the signal generator; remove all power from the AN/GRM-114; then reinstall the Spectrum Analyzer Assembly A1A18 to the Front Panel. Apply power to the AN/GRM-114, then to the signal generator.
- (43) Reduce the signal generator output in 10 dB steps from  $-30$  dBm to  $-100$  dBm and check that the signal displayed on the CRT decreases in 10 dB  $\pm 2$  dB steps.
- (44) Set the signal generator for an output of  $-70$  dBm and set the AN/GRM-114 FREQUENCY MHz thumbwheels to 1260000.
- (45) Verify that the signal displayed on the CRT is at the fifth major division left of the center graticule  $\pm 2$  minor divisions. If the signal displayed is not correct, adjust A1A18A1R37 for the correct signal display.
- (46) Set the FREQUENCY MHz thumbwheels to 125 000 0 and check that the signal displayed on the CRT is at the fifth major division right of the center graticule  $\pm 2$  minor divisions. If the signal displayed is not correct, adjust A1A18A1R37 for the correct signal display.
- (47) Repeat steps (44) through (46) until the adjustments to A1A18A1R37 are balanced.
- (48) Set the ANALY DISPR control fully cw and the FREQUENCY MHz thumbwheels to 1305000.
- (49) Verify that the signal displayed on the CRT is at the fifth major division right of the center graticule  $\pm 2$  minor divisions. If the signal displayed is not correct, adjust A1A18A1R39 for the correct signal display.
- (50) Set the FREQUENCY MHz thumbwheels to 120 500 0 and verify that the signal displayed on the CRT is at the fifth major division left of the center graticule  $\pm 2$  minor divisions. If the signal displayed is not correct, adjust A1A18A1R39 for the correct signal display.
- (51) Repeat steps (46) through (48) until the adjustments to A1A18A1R39 are balanced.
- (52) Set the FREQUENCY MHz thumbwheels in 1 MHz steps from 1205000 to 130 500 0 and verify that the signal displayed on the CRT moves one major division  $\pm 2$  minor divisions for each 1 MHz step.
- (53) On the Dual Tone Generator A1A12 reconnect A1A12J1 to A1A12P1.
- (54) Remove all cables and test equipment, turn off power, remove power cord from power source, and reassemble the AN/GRM-114.

5-8. Component Location Diagrams. Figures 5-14 through 5-45 contain the component location diagrams referred to within the troubleshooting and alignment procedures of paragraphs 5-6 and 5-7.

5-9. Inspection. This paragraph provides a checklist useful in determining the physical condition of the AN/GRM-114 through visual inspection. Defects resulting from wear, physical damage or deterioration can be detected using this checklist.

**WARNING**

Power to the AN/GRM-114 must be disconnected while completing entire checklist.

a. Inspect AN/GRM-114 exterior for visible damage (repair or replace damaged components as required):

(1) Check for scratches, dents, punctures, badly worn areas, broken covers or other evidence reflective of possible internal damage.

(2) (Check for burned or scorched paint on AN/GRM-114 covers indicating possible AN/GRM-114 overheating.

(3) Check for evidence of corrosion.

b. Inspect AN/GRM-114 controls and indicators for defective or damaged hardware (repair or replace damaged components as required):

(1) Check for loose control knobs.

(2) Check for cracked or broken lamps.

(3) Check for burned out indicator lamps.

(4) Check for defective control knob or switch detents.

c. Inspect AN/GRM-114 connectors for visible damage (repair or replace damaged components as required):

(1) Check for corroded contacts, pins etc.

(2) Check for loose, bent or broken pins.

(3) Check for damaged connector housings or insulation.

(4) Check for improperly soldered or broken connections.

5-10. Performance Verification. Successful completion of the Performance Test (para. 5-5) and Troubleshooting (para. 5-6) flowcharts assure proper performance of the AN/GRM-114.

5-11. Disassembly Instructions.

a. General. The following procedures provide a complete breakdown of the AN/GRM-114 including all assemblies therein. Disassemble, only as far as is necessary to reach the desired assembly and/or to effect any repair.

b. Precautions and General Techniques. Mark, or otherwise identify, all disconnected electrical wiring or cables.

**WARNING**

Disconnect power cable from power source and the BATT fuse (A1A8F3) from rear of AN/GRM-114 before disassembling any portion of the equipment.

Table 5-13 provides disassembly sequences for any module to be removed from the AN/GRM-114. Use this table before proceeding to the actual disassembly procedure for the module to be removed. This allows removal of a module using a minimum number of disassembly steps. Find the desired module to be removed in the first column of table 5-13, then, in column three, locate modules which must be removed before removing the desired module. The module removal paragraphs are listed in column four. When necessary, refer to component location diagrams located at the end of the alignment procedures to find referenced connectors, jacks, and potentiometers.

**CAUTION**

Use extreme care when unsoldering wires from feed-thru capacitors. Carefully lift wires straight out rather than pulling them to side.

Do not bend semi-rigid coax cables.

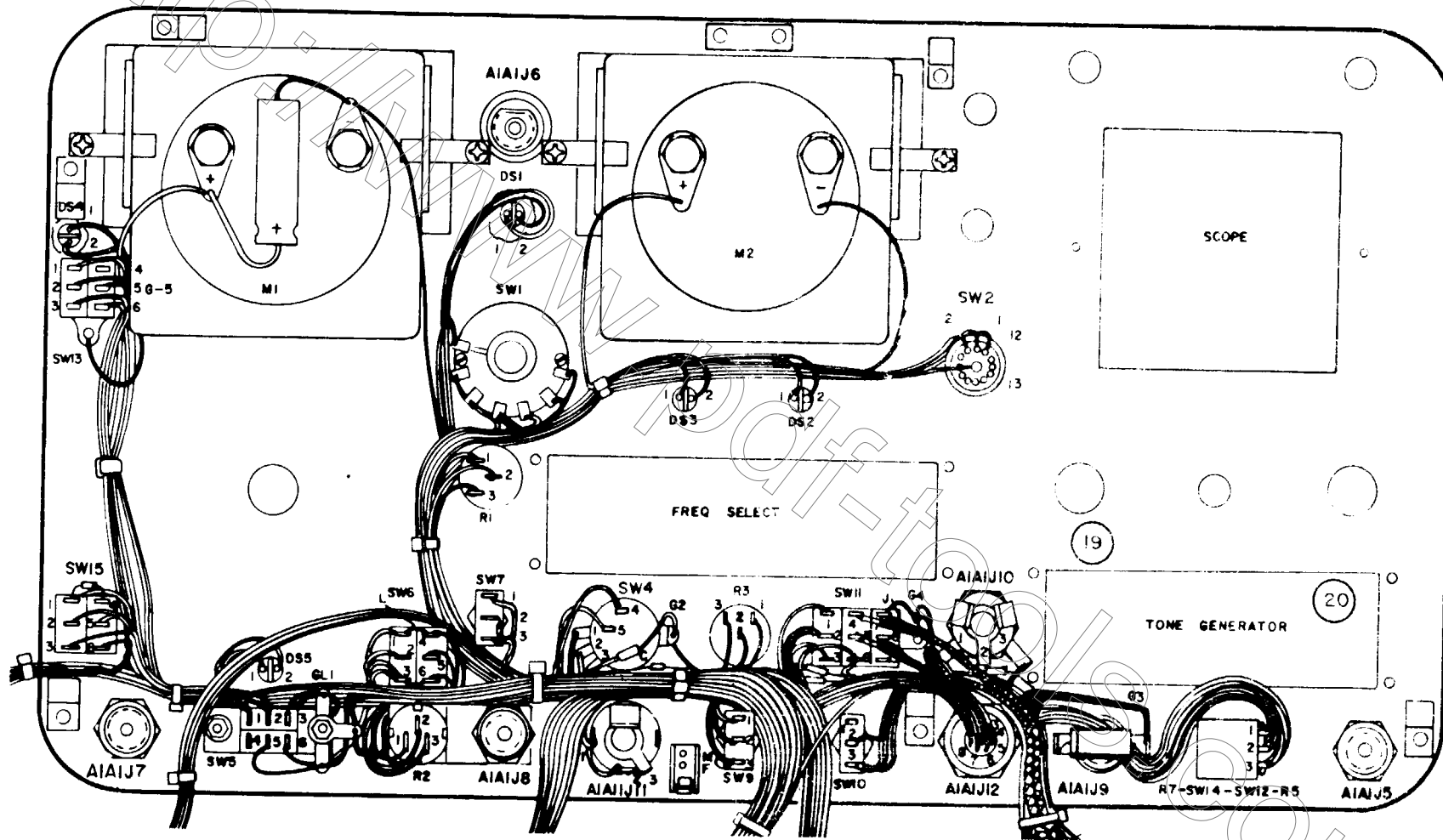


Figure 5-14. Front panel A1A1 (rear view) component location diagram

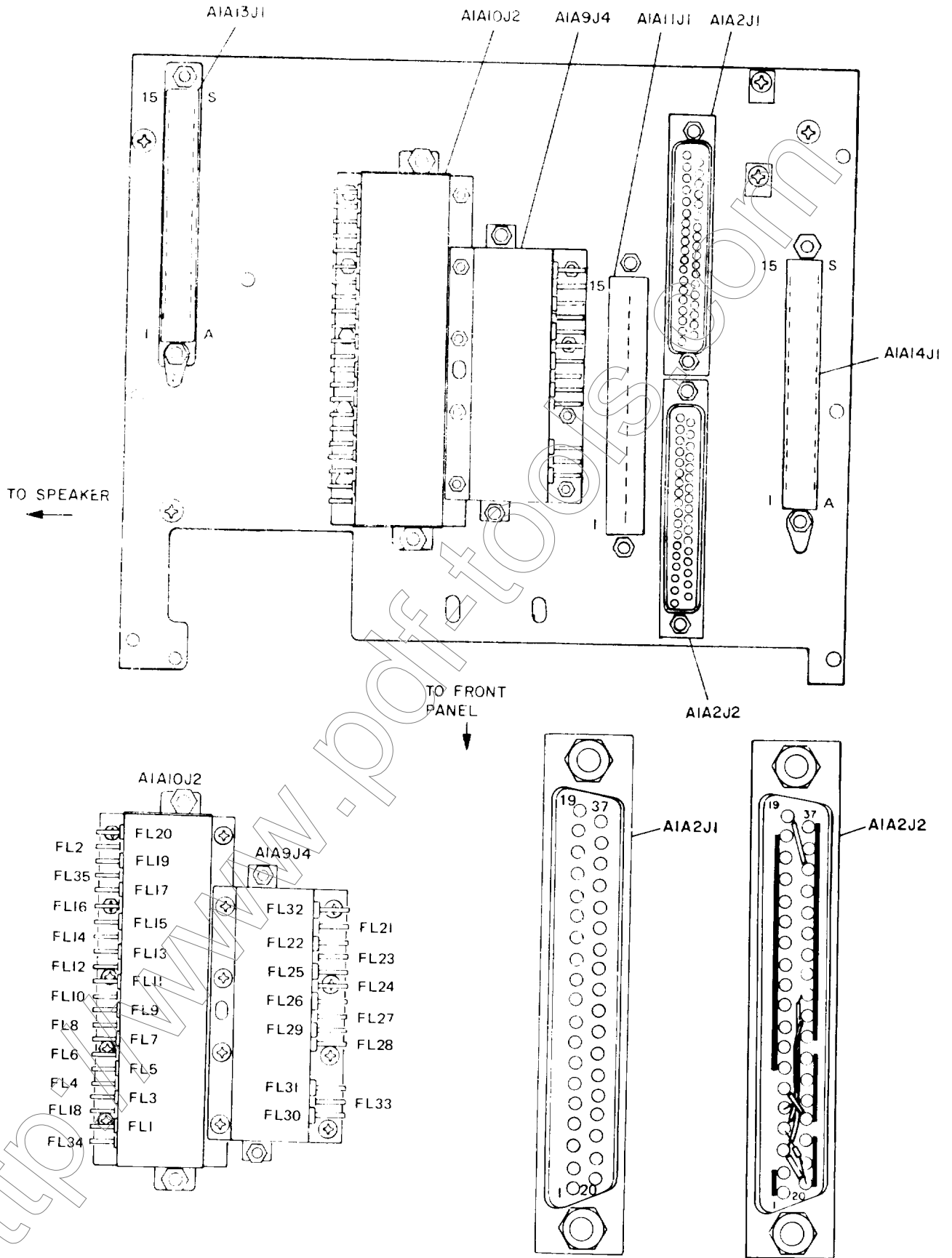


Figure 5-15 Mother board A1A2 component location diagram

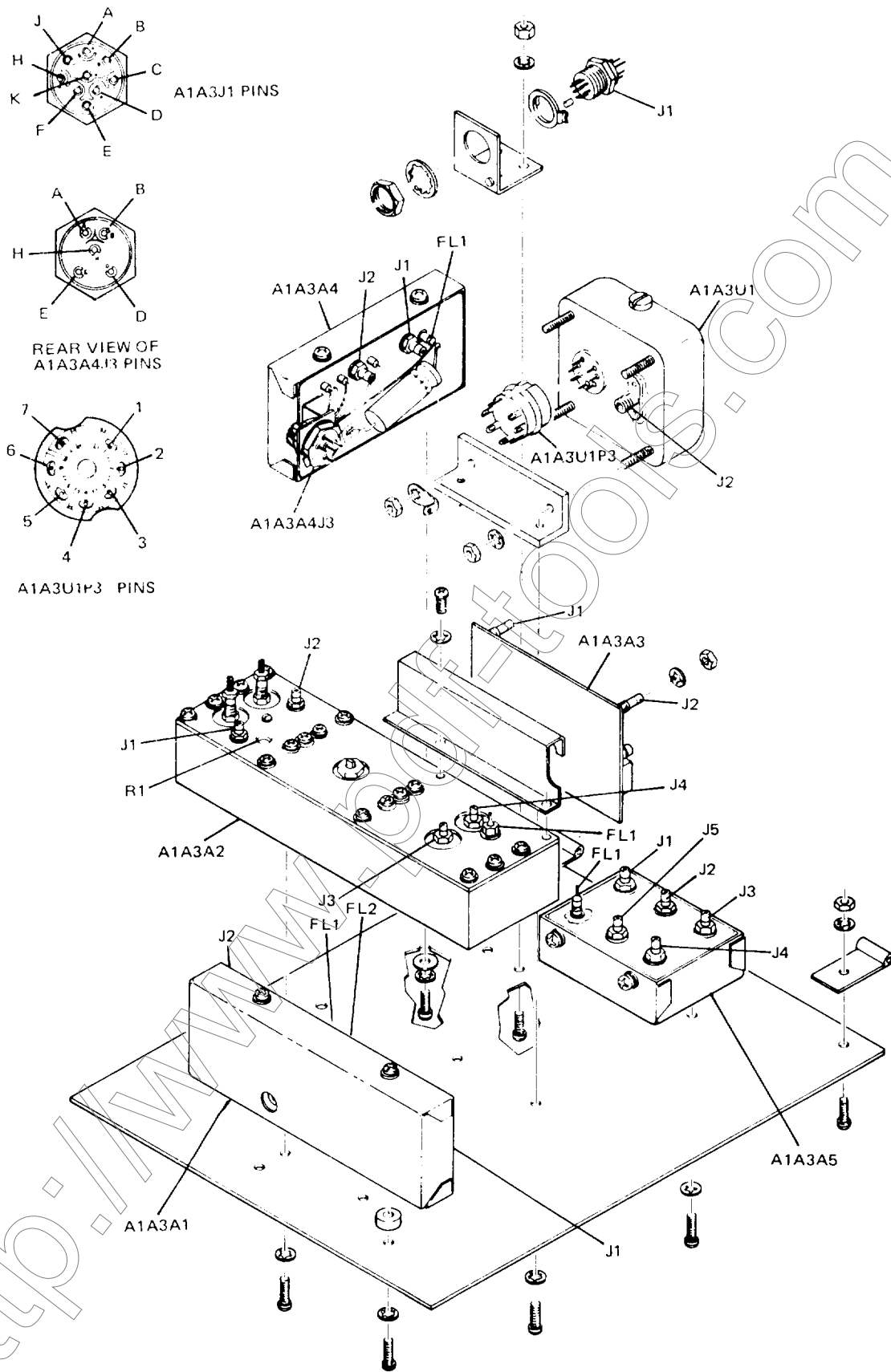


Figure 5-16. Upper floor assembly A1A3 component location diagram

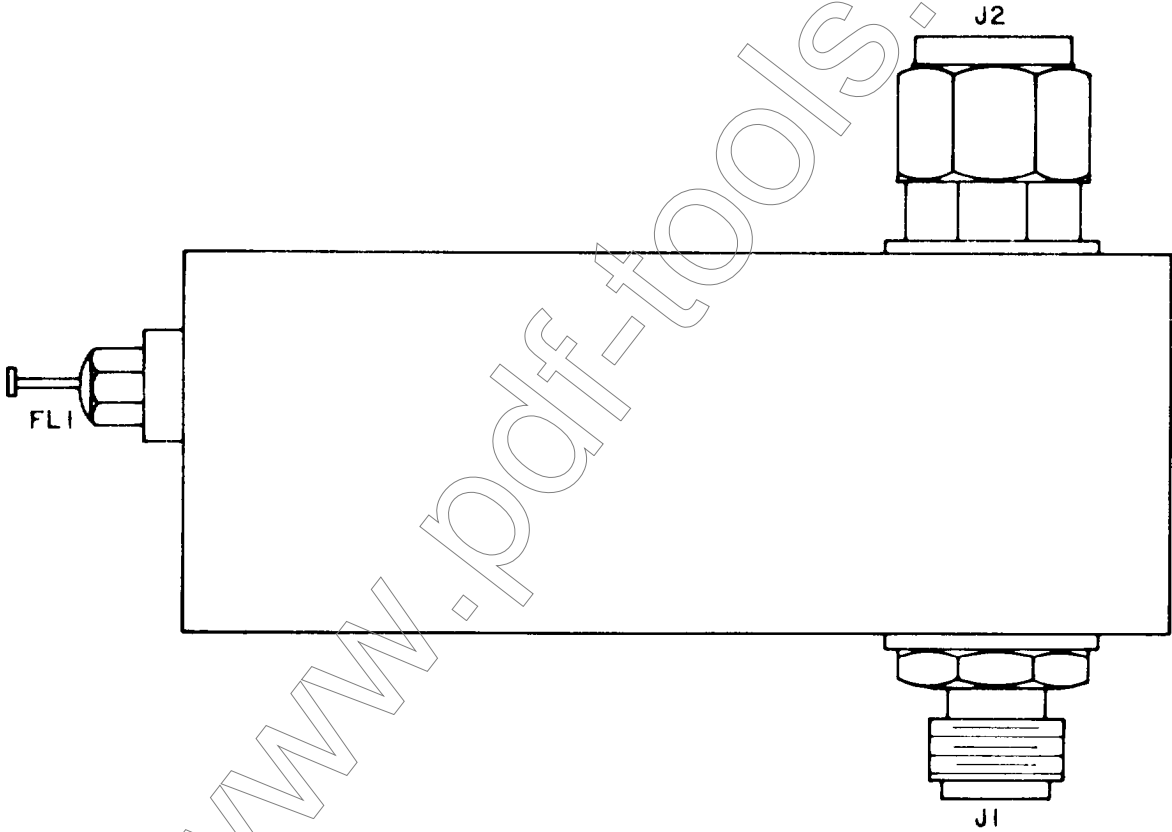


Figure 5-17. Transmitter sensor A1A4 component location diagram



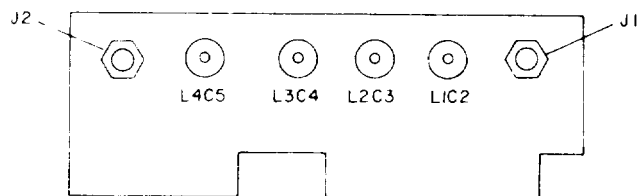


Figure 5-18. 108 MHz bandpass filter A1A5 component location diagram

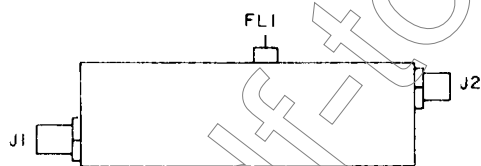


Figure 5-19. 1200 MHz amplifier A1A6 component location diagram

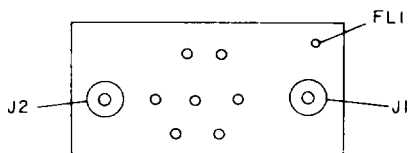


Figure 5-20. Static discharge protector A1A7 component location diagram.

http://www...

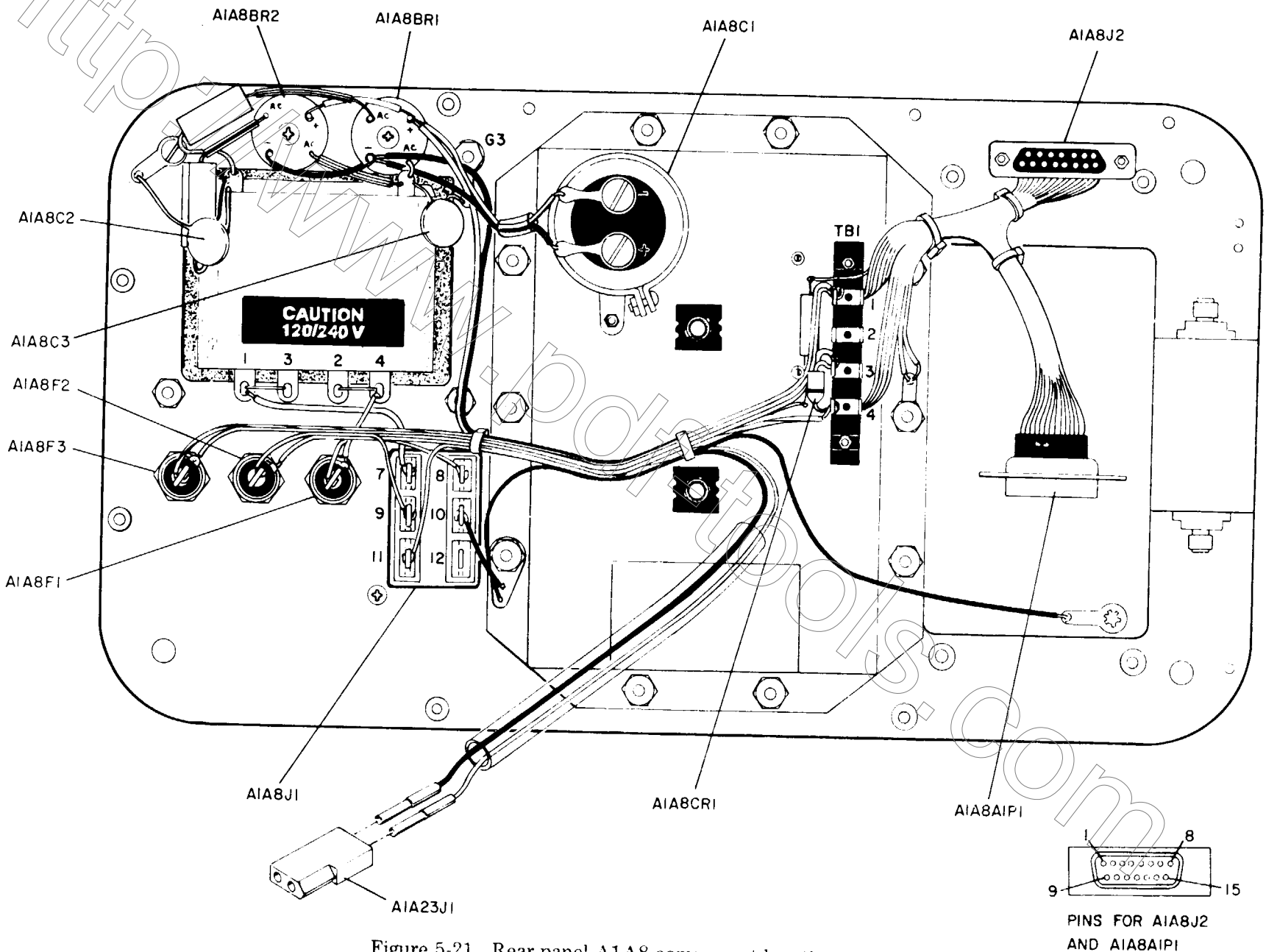


Figure 5-21. Rear panel A1A8 component location diagram

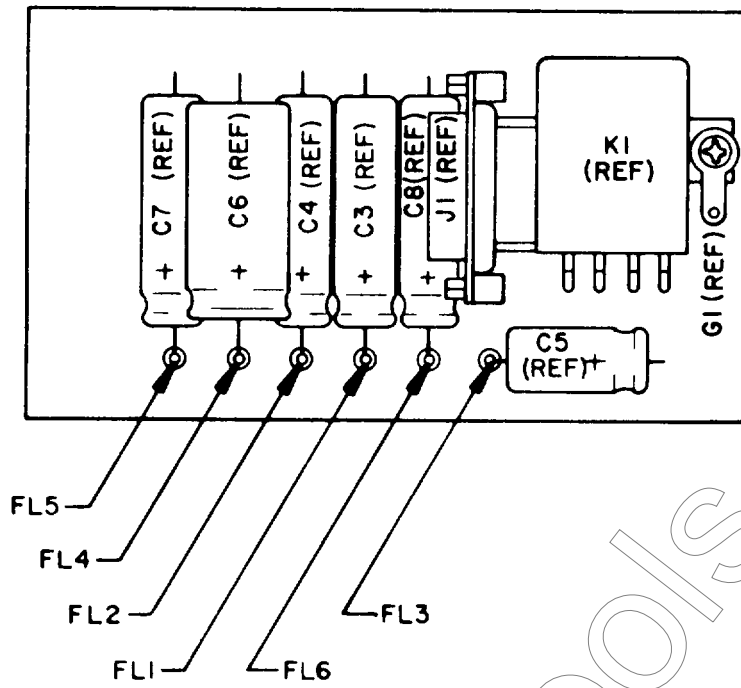


Figure 5-22. Duty cycle regulator A1A8A1 component location diagram

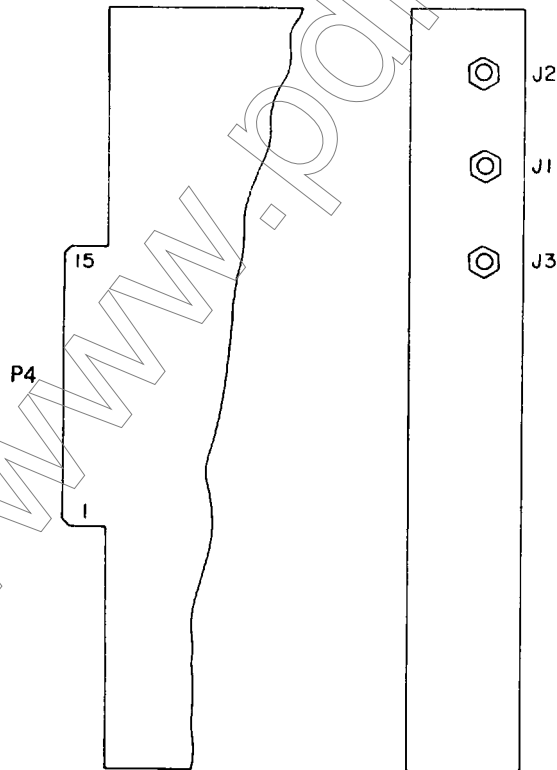


Figure 5-23. High frequency phase lock loop A1A9 component location diagram

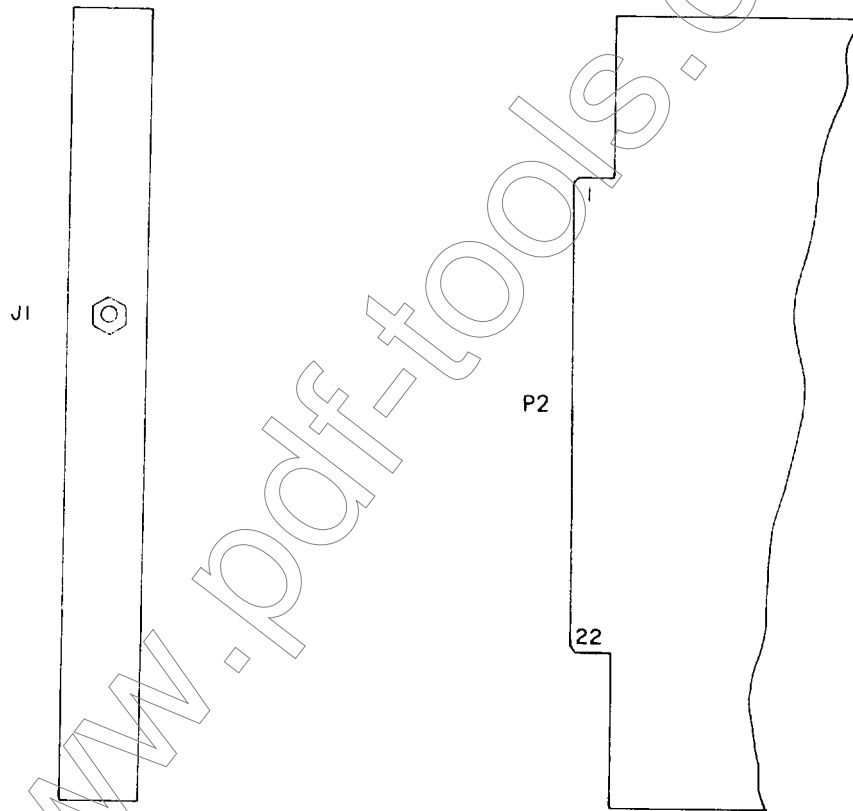


Figure 5-24. 79-80 MHz loop A1A10 component location diagram

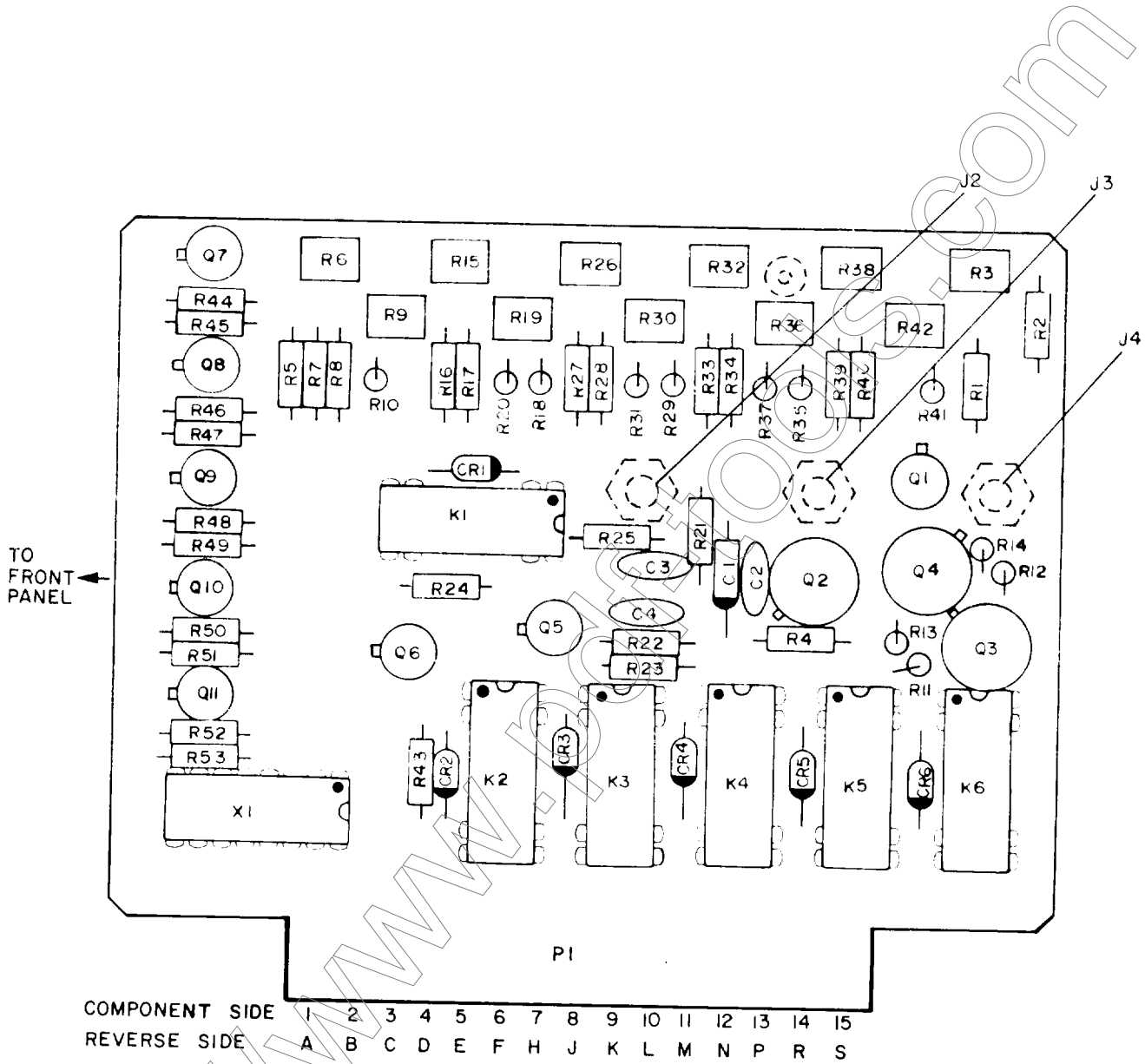


Figure 5-25. VCO tuner A1A11 component location diagram

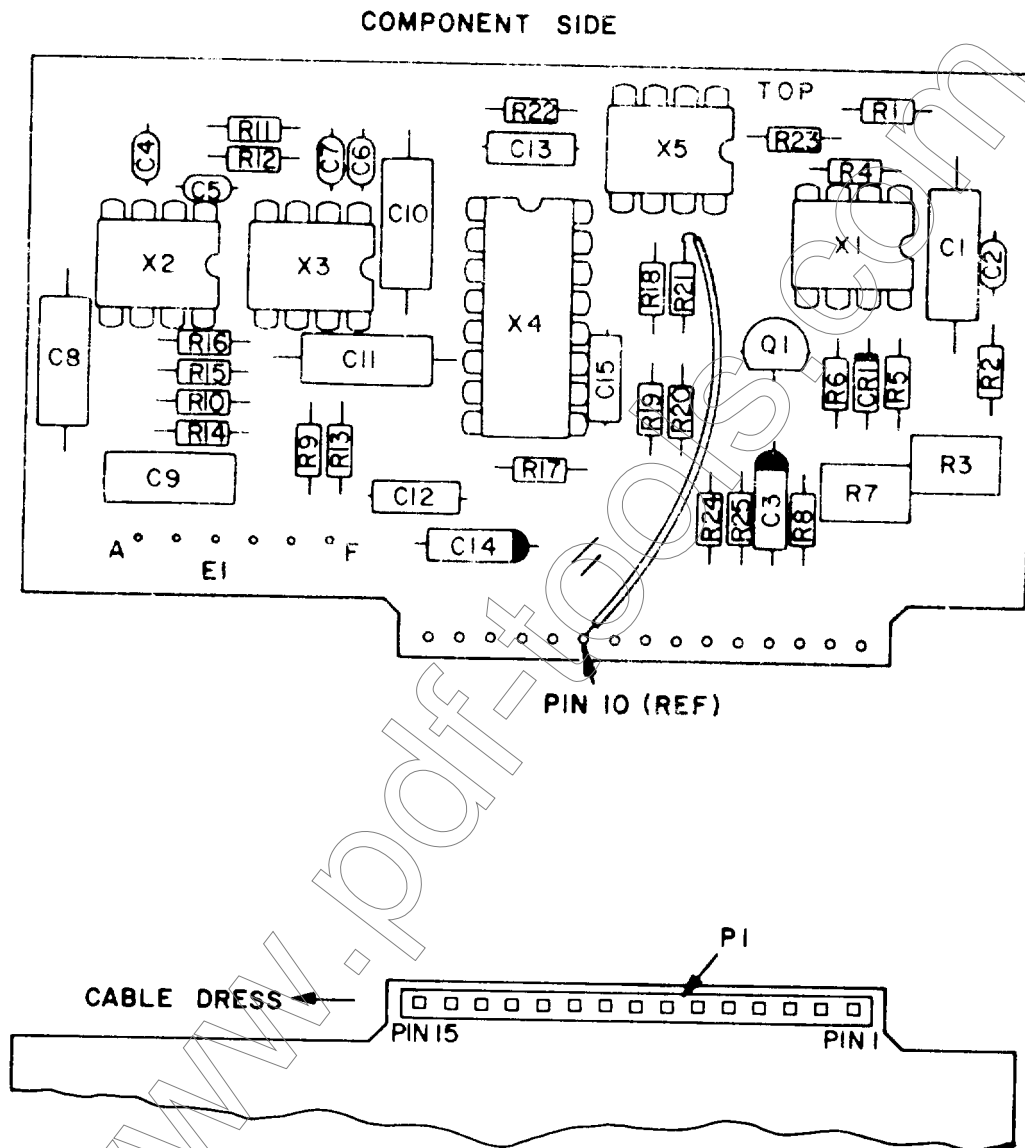


Figure 5-26. Dual tone generator A1A12 component location diagram

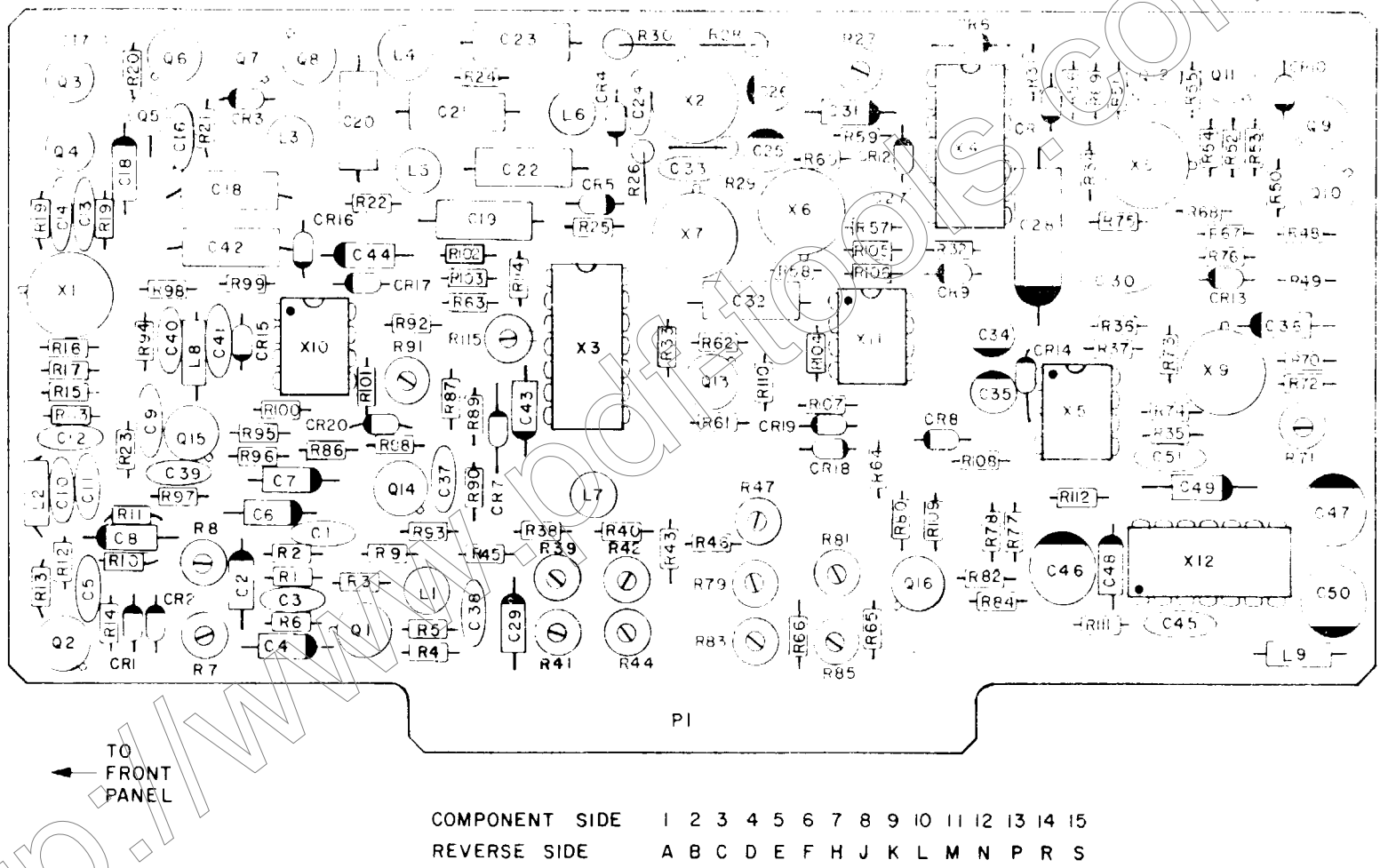


Figure 5-27. 250 kHz I.F. monitor audio circuit board A1A13 component location diagram

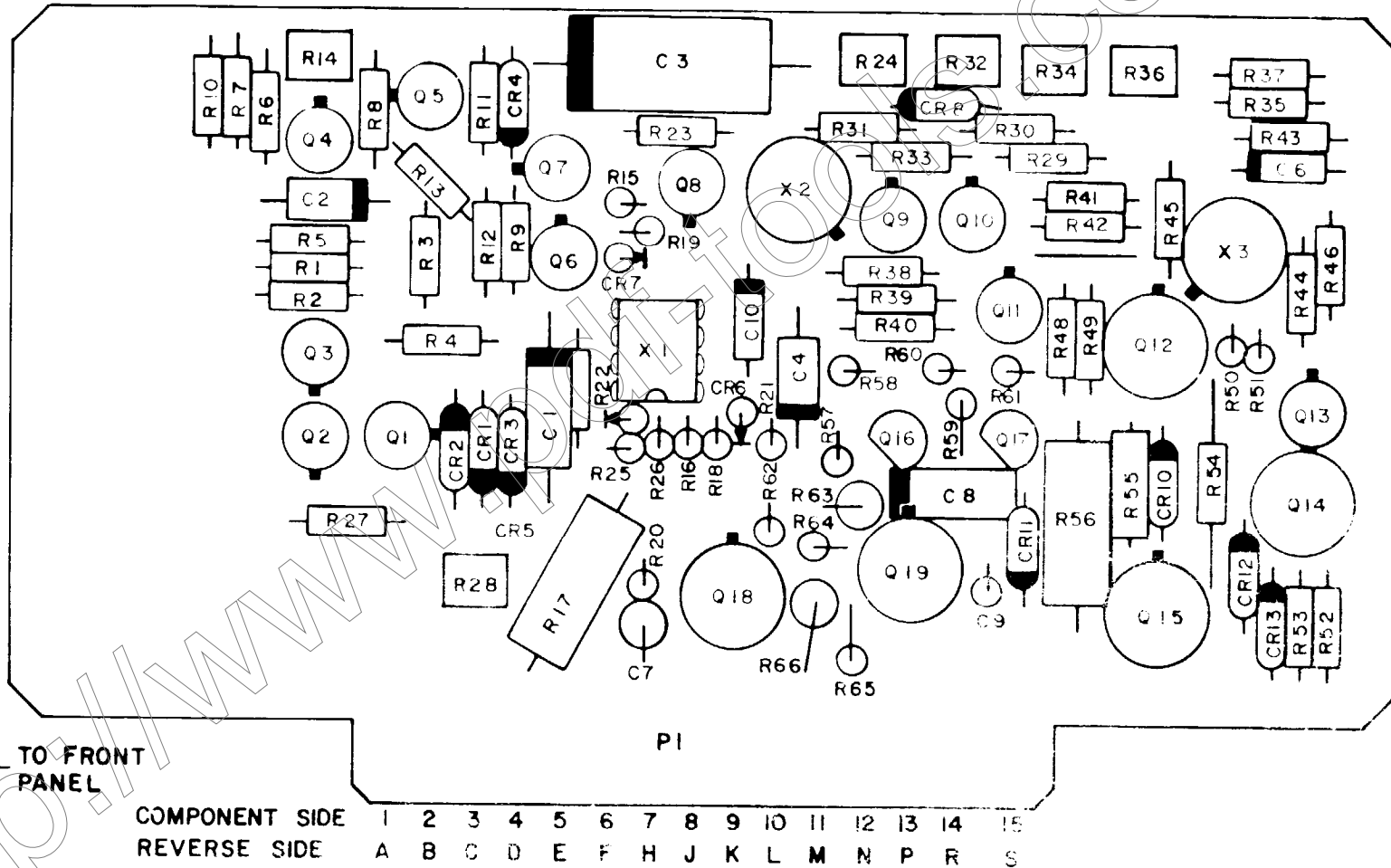


Figure 5-28. Regulator and power supply A1A14 component location diagram



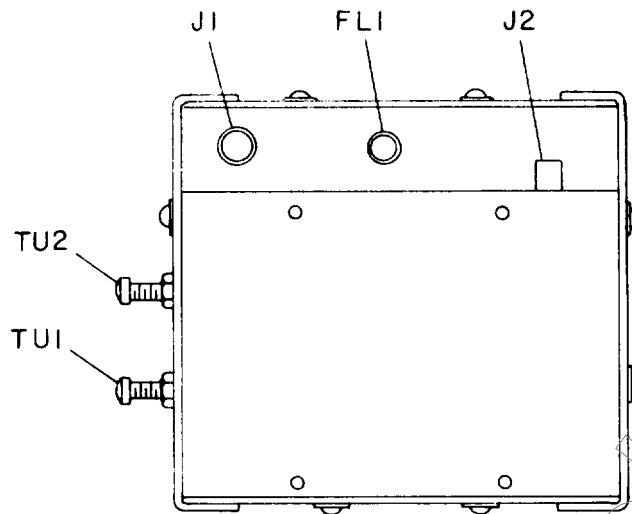


Figure 5-29. 1080 MHz multiplier amplifier A1A15 component location diagram

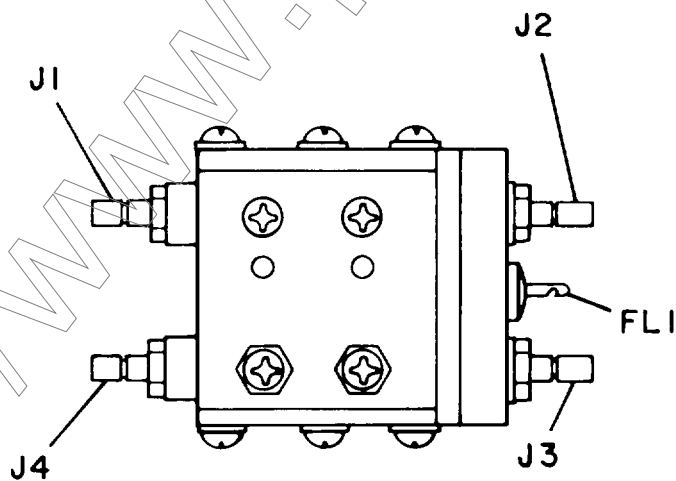


Figure 5-30. 1200 MHz diode switch A1A16 component location diagram

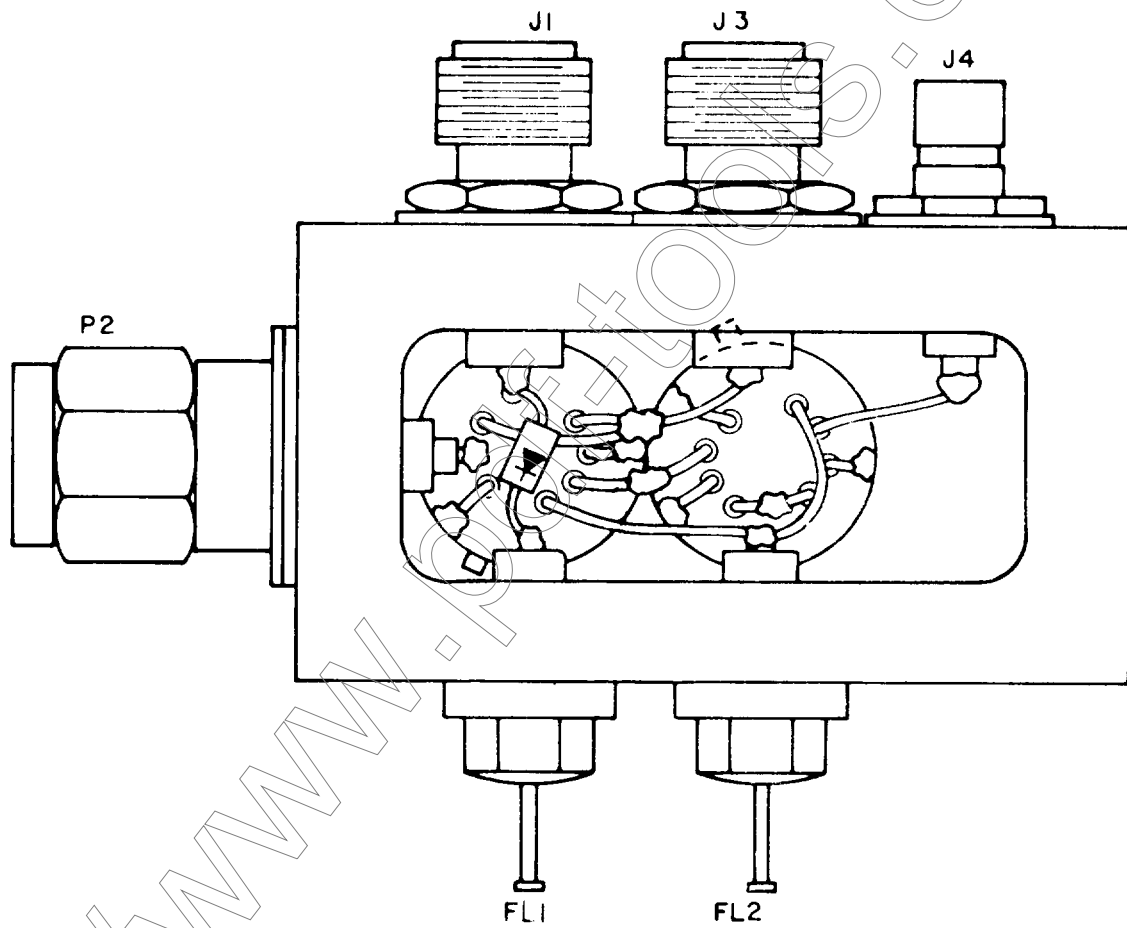


Figure 5-31. Power monitor AI A1A17 component location diagram

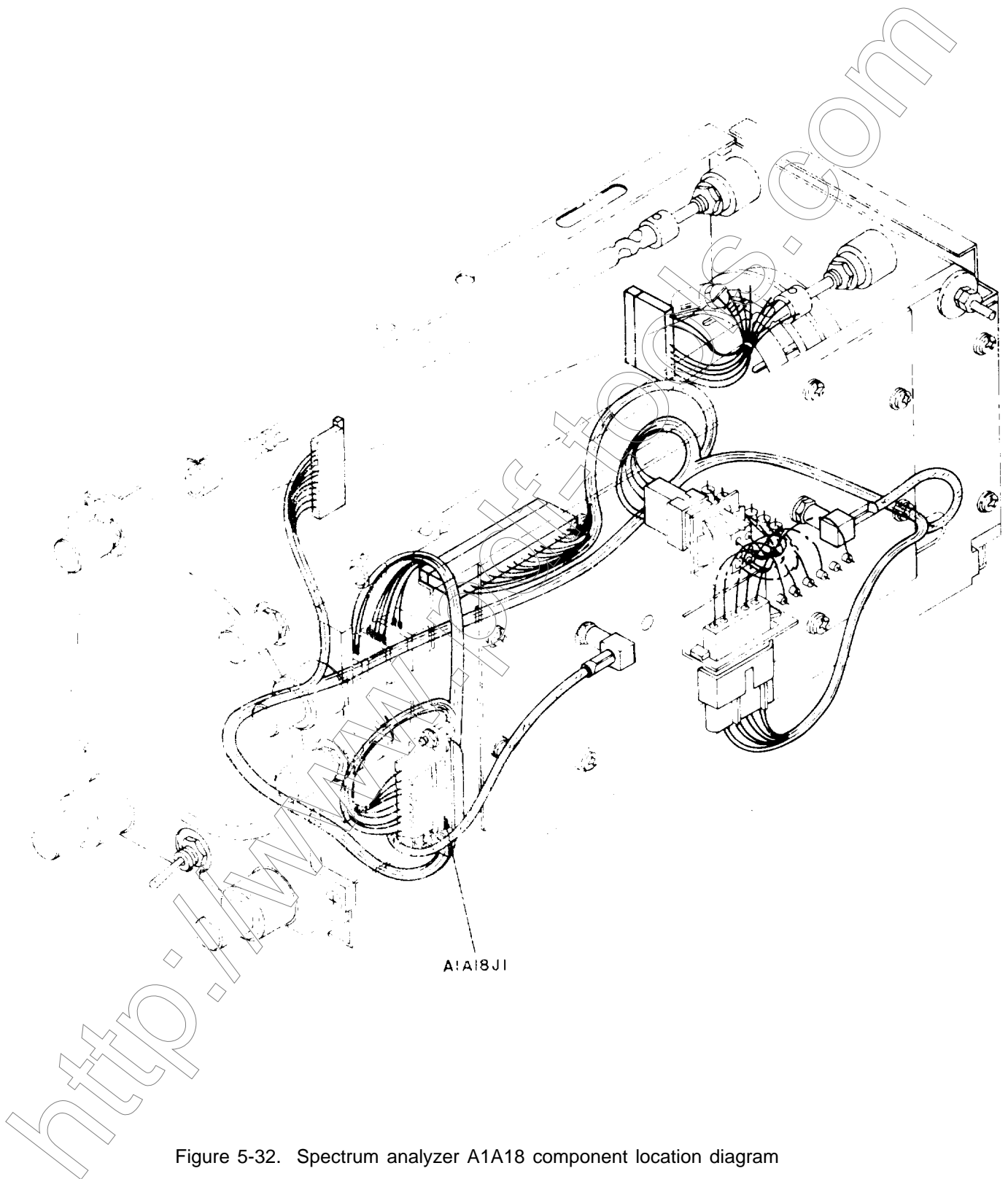


Figure 5-32. Spectrum analyzer A1A18 component location diagram

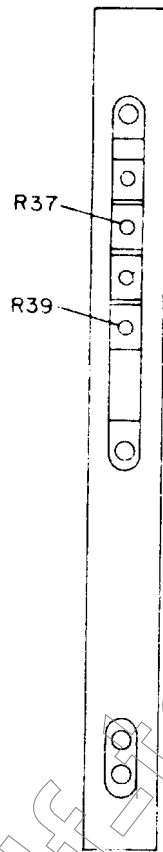


Figure 5-33. Spectrum analyzer module no. 1 A1A18A1 component location diagram

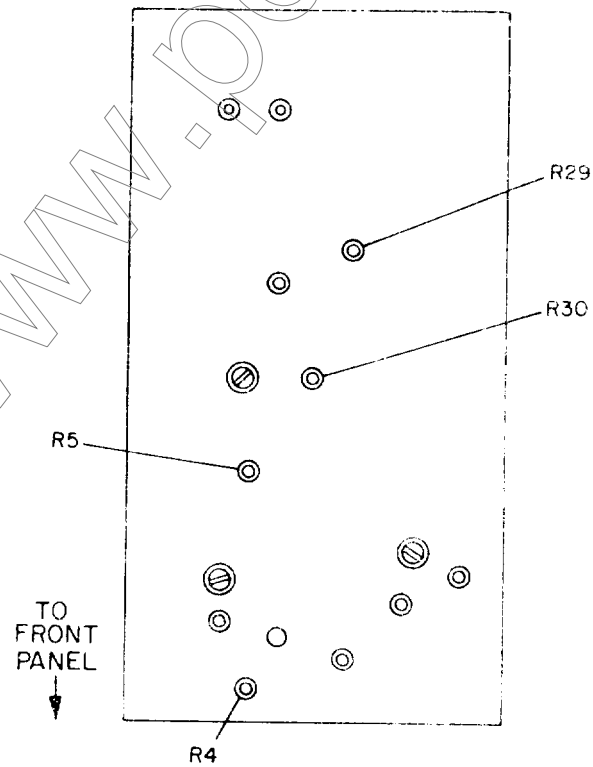


Figure 5-34. Spectrum analyzer module No. 2 A1A18A3 component location diagram

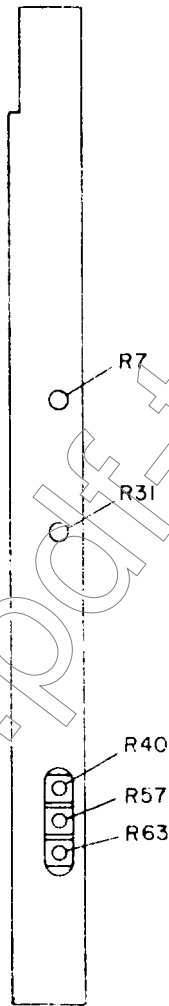


Figure 5-35. Oscilloscope main circuit board A1A18A4 component location diagram

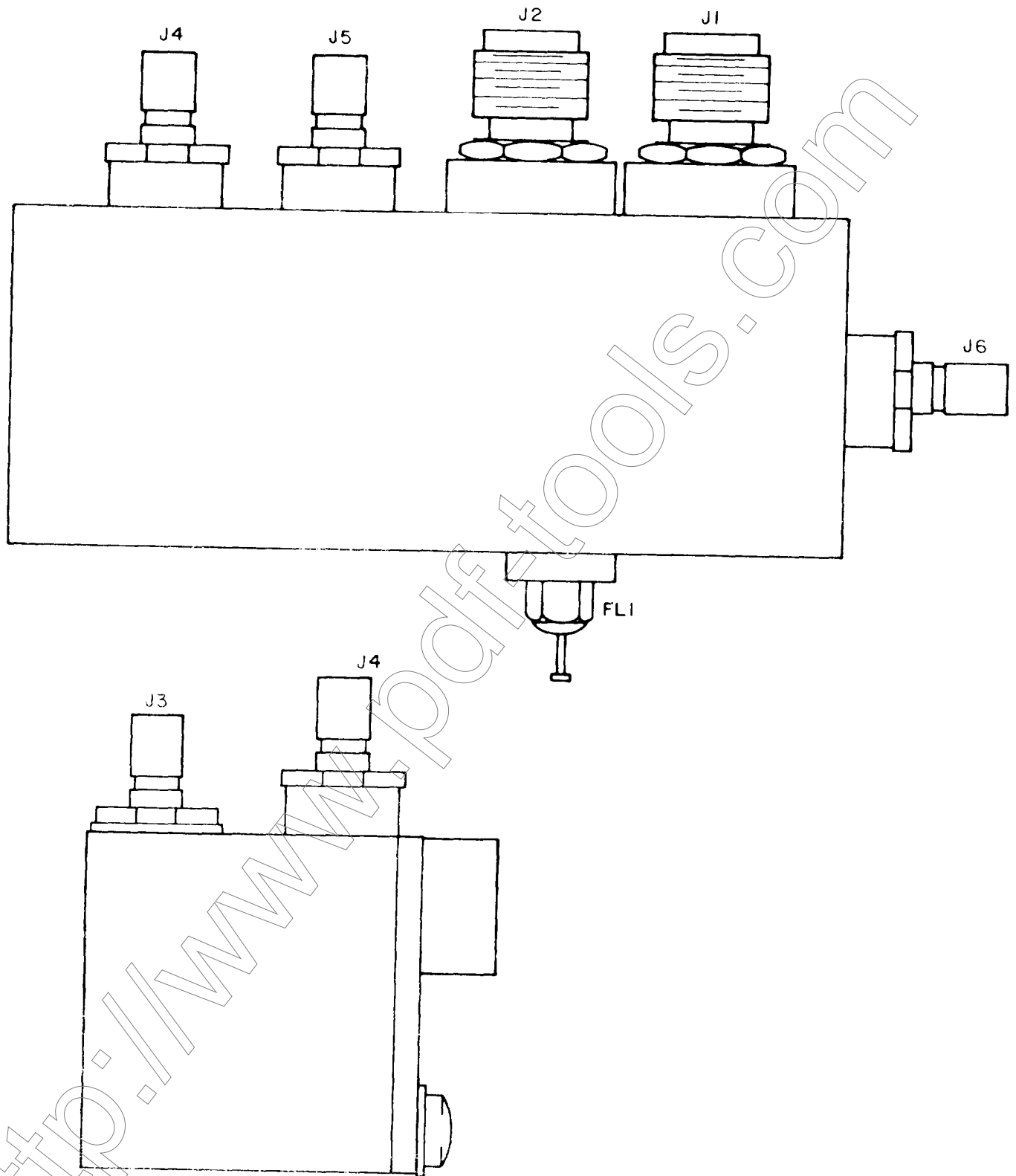


Figure 5-36. 1st mixer A1A19 component location diagram

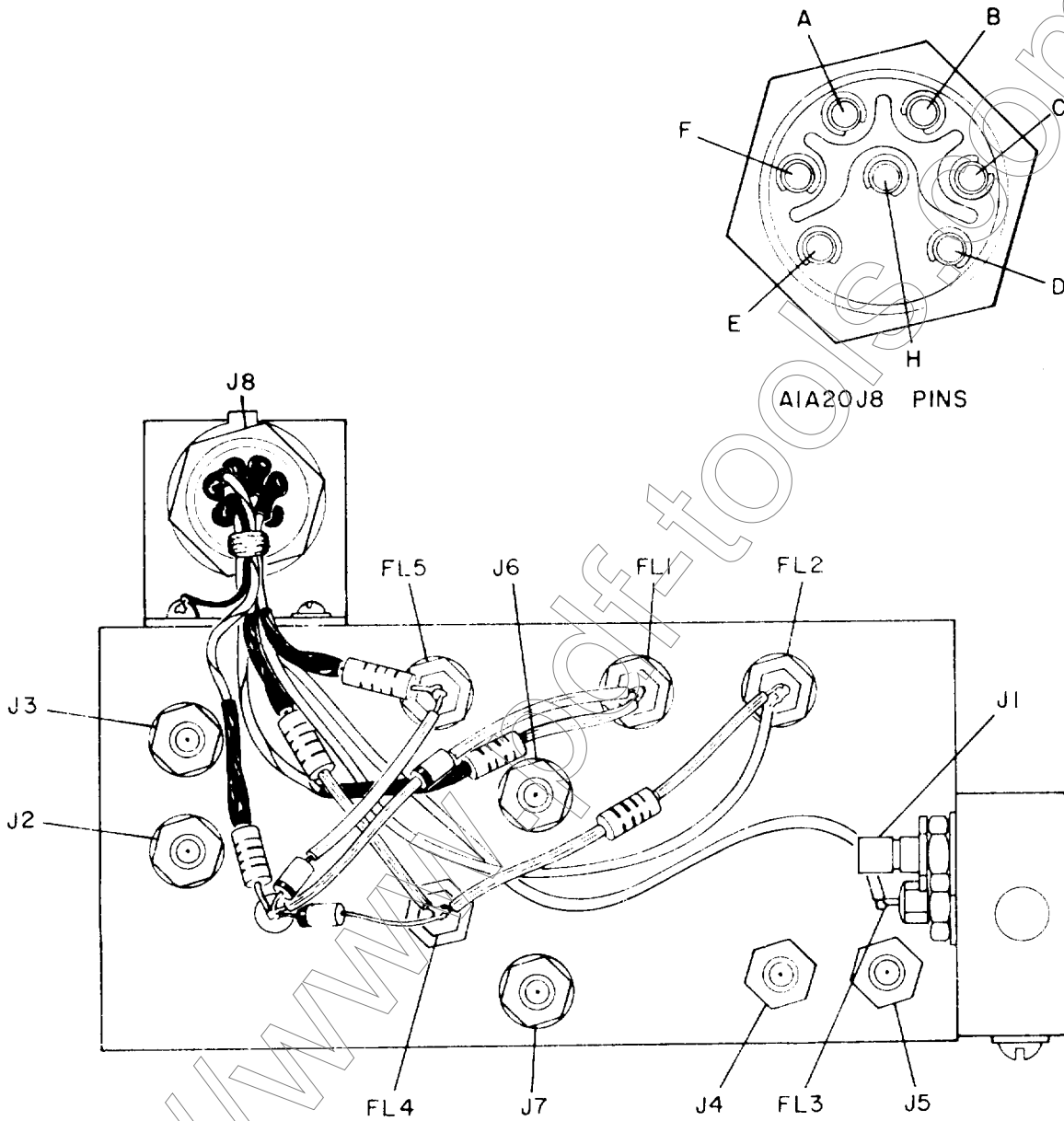


Figure 5-37. 2nd mixer A1A20 component location diagram

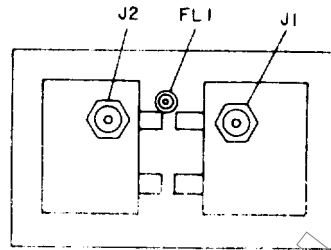


Figure 5-38. 100 MHz filter A1A21 component location diagram

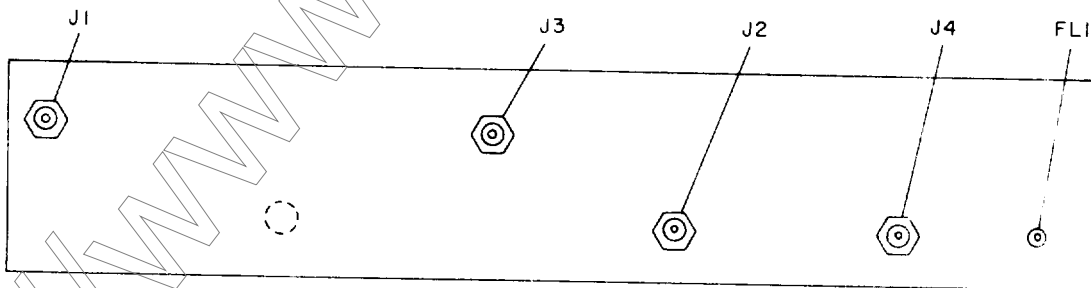


Figure 5-39. 100 MHz amplifier/108 MHz mixer A1A24A1 component location diagram



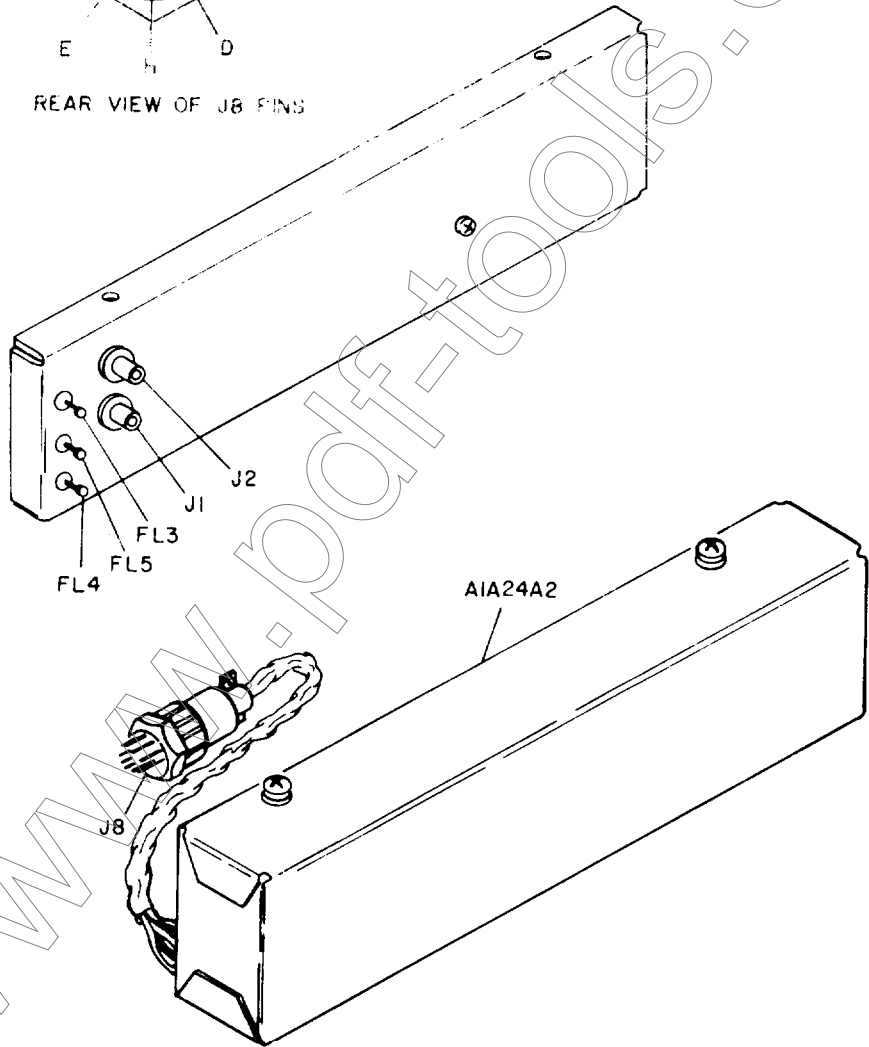
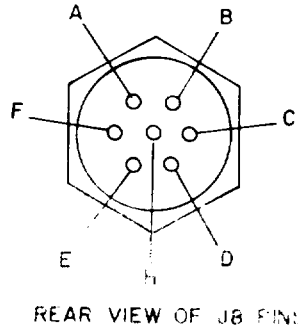


Figure 5-40. 120 MHz receiver A1A24A2 component location diagram

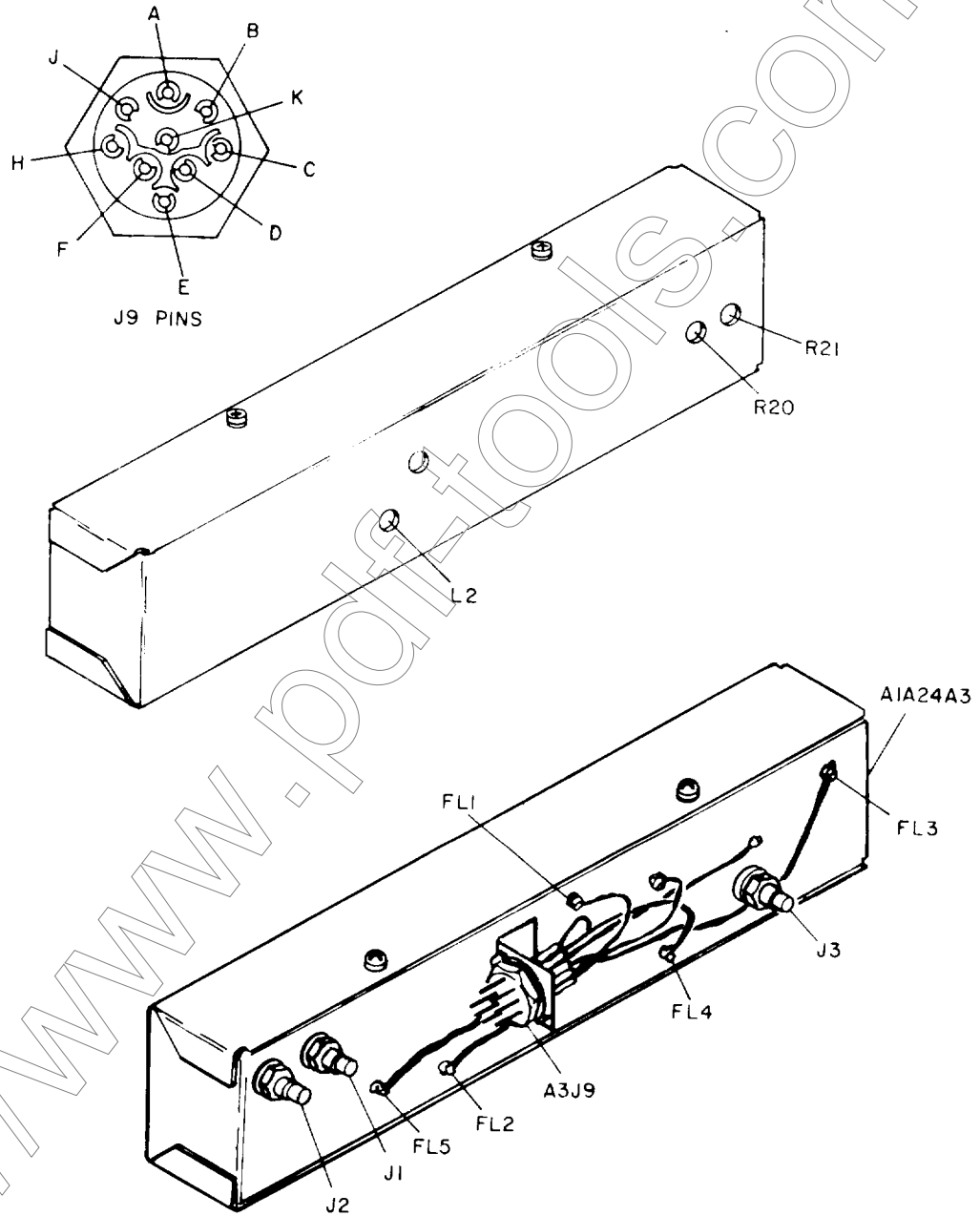


Figure 5-41. FM/AM generator A1A24A3 component location diagram

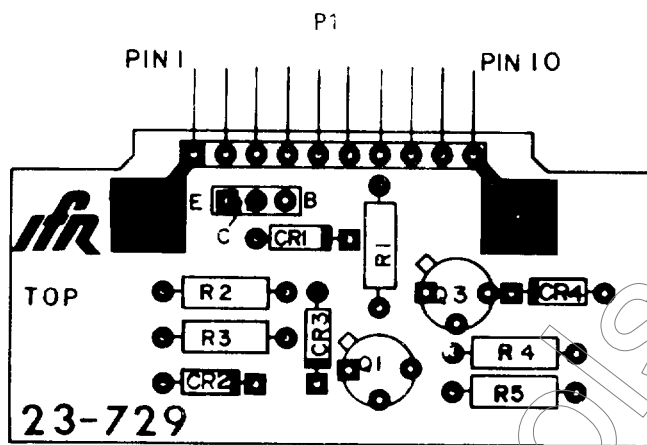


Figure 5-42. Relay driver A1A25 component location diagram

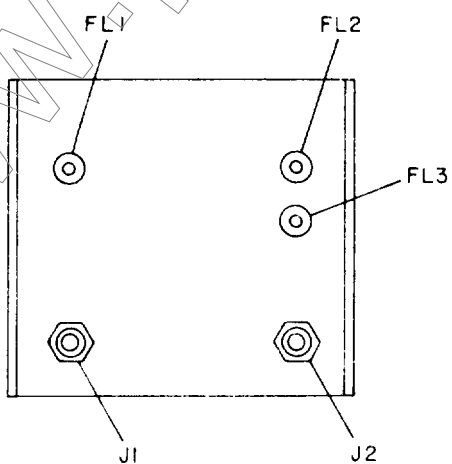


Figure 5-43. High level amplifier A1A28 component location diagram

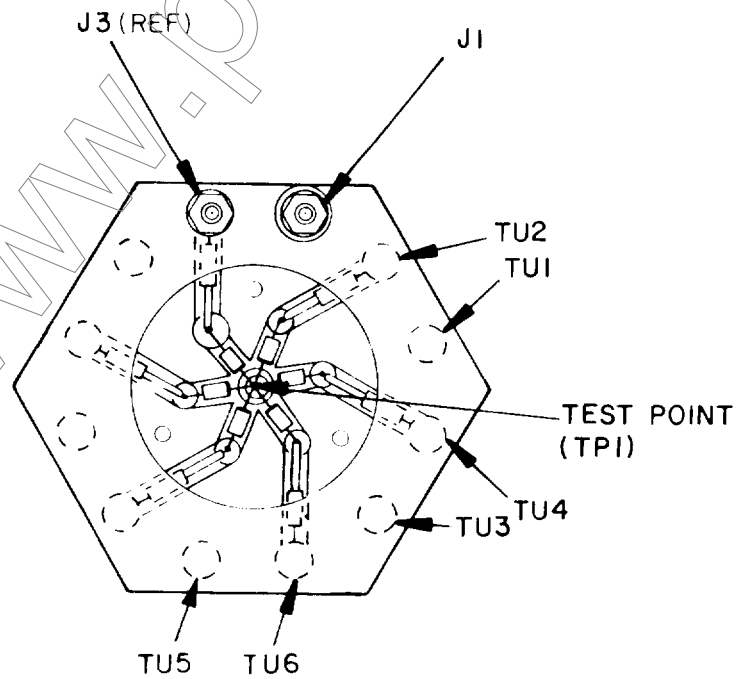
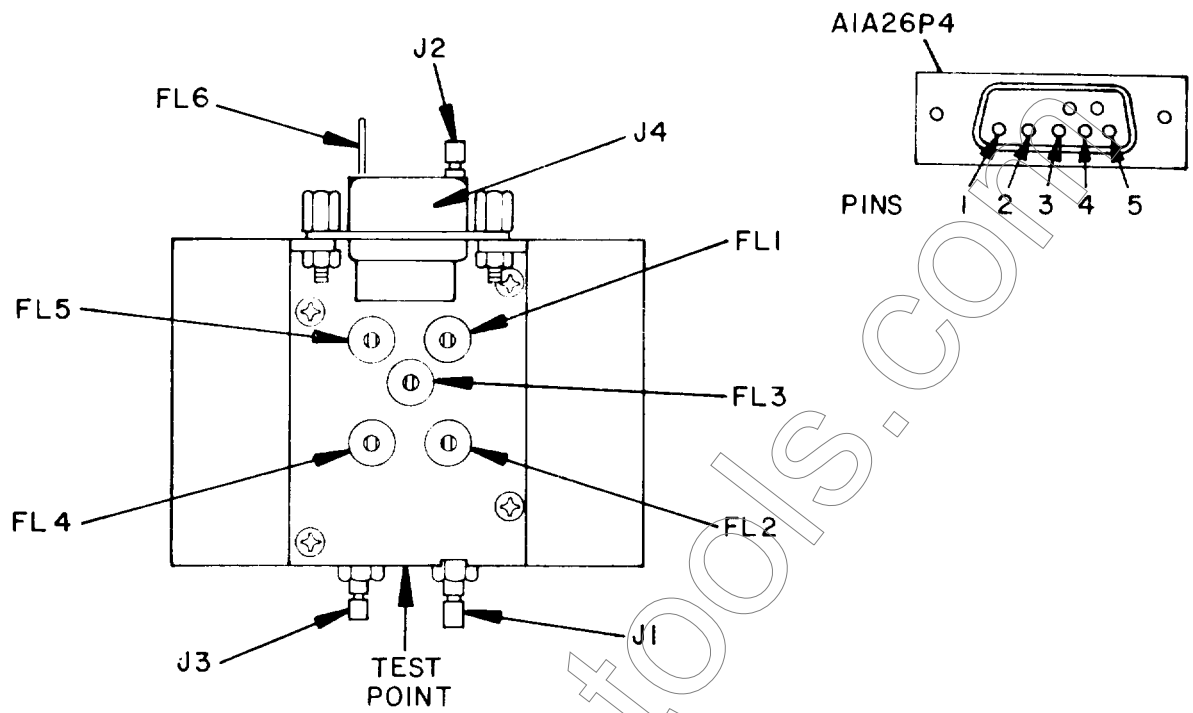


Figure 5-44. High frequency multiplier/mixer A1A26 component location diagram

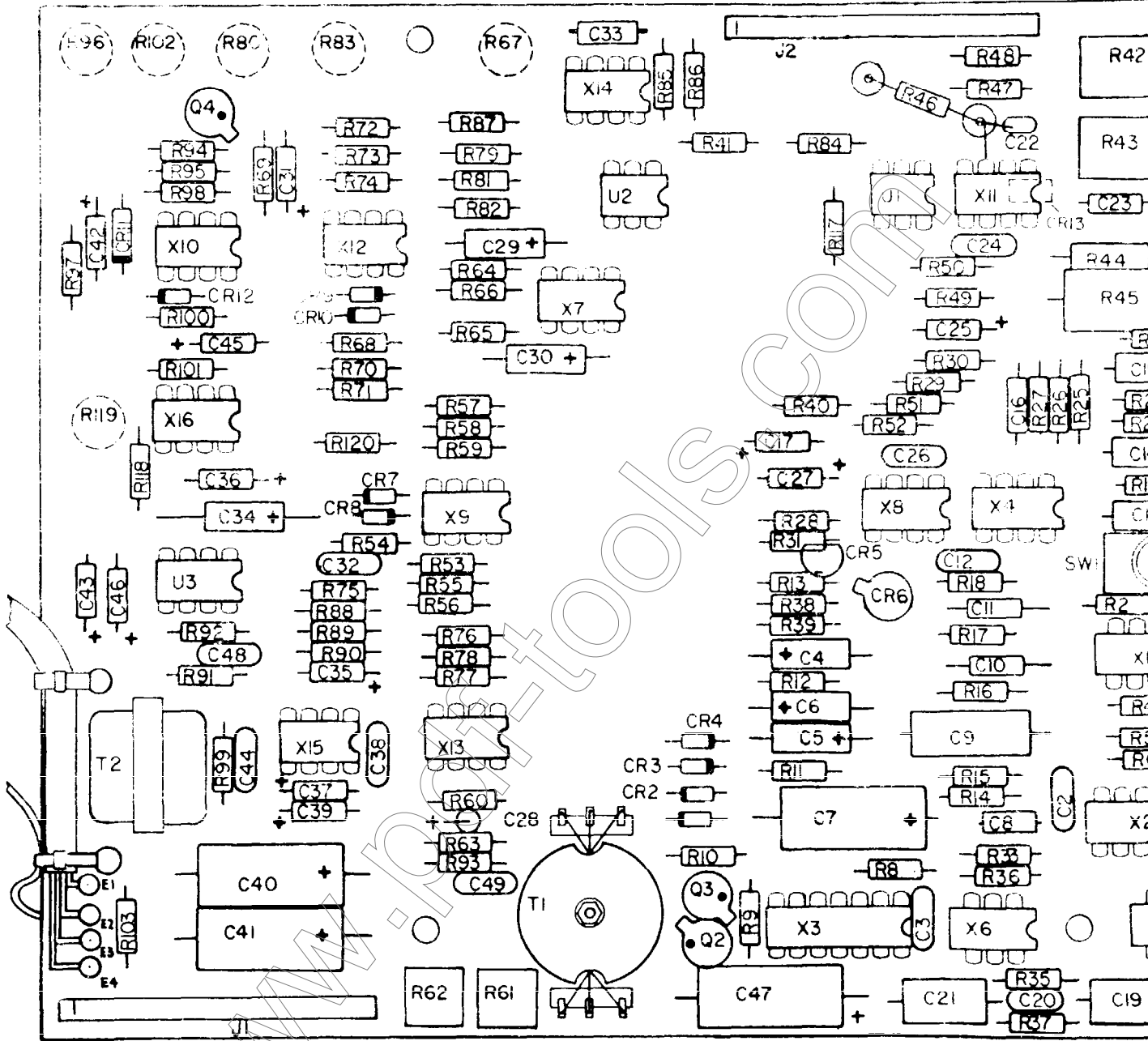


Figure 5-45. MM-100 assembly A2A1A1

http://www.militarytools.com

Table 5-13. Disassembly Sequence

Module to be removed	Module disassembly steps	Modules which must be removed first	Module removal steps
Heterodyne Amplifier , 2 Prescaler (A1A3A1)	d. (2)-(5)	Case Swing Upper Floor out	c. (1)-(6) d. (1)
1200-2200 MHz Oscillator (A1A3A2)	d. (6)-(10)	Case Swing Upper Floor out AGC Circuit Board	c. (1)-(6) d. (1) d. (8)-(9)
AGC Circuit Board (A1A3A3)	d. (8)-(9)	Case Swing Upper Floor out	c. (1)-(6) d. (1)
TCXO Master Oscillator (A1A3U1)	d. (11)-(14)	Case Swing Upper Floor out	c. (1)-(6) d. (1)
TCXO Master Oscillator Output Distribution Amplifier (A1A3A5)	d. (15)-(17)	Case Swing Upper Floor out	c. (1)-(6) d. (1)
Clock Divider (A1A3A4)	d. (18)-(20)	Case Swing Upper Floor out	c. (1)-(6) d. (1)
2nd Mixer (A1A20)	e. (1)-(4)	Case Swing Upper Floor out	C. (1)-(6) d. (1)
100 MHz Filter (A1A21)	e. (5)-(9)	Case	c. (1)-(6)
Speaker	e. (10)-(13)	Case	C. (1)-(6)
1st Mixer (A1A19)	e. (14)-(17)	Case Swing Upper Floor out	c. (1)-(6) d. (1)
1200 MHz Diode Switch (A1A16)	e. (18)-(23)	Case 100 MHz Filter	c. (1)-(6) c. (5)-(9)
High Frequency Multiplier/ Mixer (A1A26)	e. (25)-(29)	Case Capacitor A1A8C1	c. (1)-(6) e. (24)
Regulator and Power Supply Circuit Board (A1A14)	f. (1)-(3)	Case Swing Upper Floor out Capacitor A1A8C1	c. (1)-(6) d. (1) e. (24)
VCO Tuner Circuit Board (A1A11)	f. (4)-(7)	Case Swing Upper Floor out	c. (1)-(6) d. (1)
High Frequency Phase Lock Assembly (A1A9)	f. (8)-(10)	Case Swing Upper Floor out	c. (1)-(6) d. (1)

Table 5-13. Disassembly Sequence – Continued

Module to be removed	Module disassembly steps	Modules which must be removed first	Module removal steps
79-80 MHz Loop Assembly (A1A10)	f. (11)-(13)	Case Swing Upper Floor out	c. (1)-(6) d. (1)
250 kHz I.F. Monitor Audio Circuit Board (A1A13)	f. (14)-(16)	Case Swing Upper Floor out 1st Mixer	c. (1)-(6) d. (1) e. (14)-(17)
1080 MHz Multiplier Amplifier (A1A15)	f. (17)-(20)	Case Swing Upper Floor out 2nd Mixer 1st Mixer 250 kHz I.F. Monitor Audio Circuit Board	c. (1)-(6) d. (1) e. (1)-(4) e. (14)-(17) f. (14)-(16)
1200 MHz Amplifier (A1A6)	f. (21)-(24)	Case Swing Upper Floor out 2nd Mixer 1st Mixer 250 kHz I.F. Monitor Audio Circuit Board 1080 MHz Multiplier Amplifier	c. (1)-(6) d. (1) e. (1)-(4) e. (14)-(17) f. (14)-(16) f. (17)-(20)
High Level Amplifier (A1A28)	f. (25)-(28)	Case Swing Upper Floor out 1st Mixer Semi-rigid coax cables from 1200 MHz Diode Switch	c. (1)-(6) d. (1) e. (14)-(17) e. (19)
Static Discharge Protector (A1A7)	f. (29)-(32)	Case Speaker	c. (1)-(6) e. (10)-(13)
108 MHz Bandpass Filter (A1A5)	f. (33)-(35)	Case	c. (1)-(6)
Relay Driver (A1A25)	f. (36)-(37)	Case 108 MHz Bandpass Filter	c. (1)-(6) f. (33)-(35)
FM/AM Generator (A1A24A3)	g. (3)-(6)	Case Swing Lower Floor out	c. (1)-(6) g. (1)-(2)
100 MHz Amplifier/ 108 MHz Mixer (A1A24A1)	g. (7)-(10)	Case Swing Lower Floor out FM/AM Generator	c. (1)-(6) g. (1)-(2) g. (3)-(6)

Table 5-13. Disassembly Sequence – Continued

Module to be removed	Module disassembly steps	Modules which must be removed first	Module removal steps
120 MHz Receiver (A1A24A2)	g. (11)-(14)	Case Swing Lower Floor out FM/AM Generator 100 MHz Amplifier/108 MHz Mixer	c. (1)-(6) g. (1)-(2) g. (3)-(6) g. (7)-(10)
Duty Cycle Regulator (A1A8A1)	h. (1)-(4)	Case Swing Upper Floor out	c. (1)-(6) d. (1)
Transmitter Sensor (A1A4)	h. (5)-(8)	Case	c. (1)-(6)
20 dB Pad (A1A8AT1)	h. (9)-(12)	Case Swing Upper Floor out Duty Cycle Regulator Transmitter Sensor	c. (1)-(6) d. (1) h. (1)-(4) h. (5)-(8)
Power Monitor (A1A17)	h. (13)	Case Swing Upper Floor out Duty Cycle Regulator Transmitter Sensor 20 dB Pad	c. (1)-(6) d. (1) h. (1)-(4) h. (5)-(8) h. (9)-(12)
Battery Modified Mechanical Assembly (A1A23)	h. (14)-(16)	Case Swing Upper Floor out	c. (1)-(6) d. (1)
Transformer	h. (17)-(19)	Case	c. (1)-(6)
Spectrum Analyzer Assembly (A1A18)	i. (4)-(11)	Case Swing Upper Floor out Tilt Front Panel forward	c. (1)-(6) d. (1) i. (1)-(3)
Dual Tone Generator (A1A12)	i. (12)-(14)	Case Swing Upper Floor out Tilt Front Panel forward Spectrum Analyzer Assembly	c. (1)-(6) d. (1) i. (1)-(3) i. (4)-(11)
FREQ. ERROR (KHz) meter	i. (15)-(17)	Case Swing Upper Floor out	c. (1)-(6) d. (1)
Frequency Select Switch Assembly (FREQUENCY MHz Thumbwheels) (A1A27)	i. (18)-(20)	Case Swing Upper Floor out FREQ. ERROR (KHz) Meter Tilt Front Panel forward	c. (1)-(6) d. (1) i. (15)-(17) i. (1)-(3)
DEVIATION (KHz)/ WATTS meter	i. (21)-(23)	Case Swing Upper Floor out 2nd Mixer	c. (1)-(6) d. (1) e. (1)-(4)



Table 5-13. Disassembly Sequence -- Continued

Module to be removed	Module disassembly steps	Modules which must be removed first	Module removal steps
ANT INPUT connector	i. (24)-(25)	Case Swing Upper Floor out Tilt Front Panel forward	c. (1)-(6) d. (1) i. (1)-(3)
DEV/PWR control	i. (26)-(29)	Case Swing Upper Floor out Tilt Front Panel forward FREQ. ERROR (KHz) Meter	c. (1)-(3) d. (1) i. (1)-(3) i. (15)-(17)
HI LVL/ $\mu$ V x 100/NORM switch	i. (30)-(32)	Case Speaker	c. (1)-(3) e. (10)-(13)
AUTO/OFF/ZERO, BATT switch	i. (33)-(35)	Case Speaker	c. (1)-(3) e. (10)-(13)
RF LEVEL/BFO INJECTION Dial Assembly	i. (36)-(41)	Case Swing Upper Floor out Tilt Front Panel forward Speaker	c. (1)-(3) d. (1) i. (1)-(3) e. (10)-(13)
TRANS/RCVR connector	i. (42)-(43)	Case Disconnect semi-rigid coax cable from TRANS/RCVR connector	c. (1)-(3) i. (2)
PWR/OFF/BATT switch	1. (44)-(47)	Case	c. (1)-(3)
ZERO/RCVR switch	i. (18)-(50)	Case Swing Upper Floor out Tilt Front Panel forward FREQ. ERROR (KHz) meter DEV/PWR Control	c. (1)-(3) d. (1) i. (1)-(3) i. (15)-(17) i. (26)-(29)
GEN/RCVR switch	i. (51)-(53)	Case Swing Upper Floor out Tilt Front Panel forward FREQ. ERROR (KHz) Meter DEV/PWR Control ZERO/RCVR Switch	c. (1)-(3) d. (1) i. (1)-(3) i. (15)-(17) i. (26)-(29) i. (48)-(50)
RCVR WIDE/MID/NARROW switch	i. (54)-(56)	Case Swing Upper Floor out Tilt Front Panel forward FREQ. ERROR (KHz) Meter DEV/PWR Control ZERO/RCVR Switch GEN/RCVR Switch	c. (1)-(3) d. (1) i. (1)-(3) i. (15)-(17) i. (26)-(29) i. (48)-(50) i. (51)-(53)

Table 5-13. Disassembly Sequence – Continued

Module to be removed	Module disassembly steps	Modules which must be removed first	Module removal steps
10 MHz REF OUT connector	i. (57)-458)	Case Disconnect coax cable from 10 MHz REF OUT connector	c. (1)-(3) i. (2)
SQUELCH control	i. (59)-(62)	Case Swing Upper Floor out Tilt Front Panel forward FREQ. ERROR (KHz) Meter Frequency Select Switch Assembly (FREQUENCY MHz Thumbwheels)	c. (1)-(3) d. (1) i. (1)-(3) i. (15)-(17) i. (18)-(20)
EXT SPKR connector	i. (63)-(65)	Case	c. (1)-(3)
VOL control	i. (66)-(69)	Case Swing Upper Floor out Tilt Front Panel forward FREQ. ERROR (KHz) Meter Frequency Select Switch Assembly (FREQUENCY MHz Thumbwheels)	c. (1)-(3) d. (1) i. (1)-(3) i. (15)-(17) i. (18)-(20)
INT MOD/RCVR switch	i. (70)-(72)	Case	c. (1)-(3)
AM/FM switch	i. (73)-(75)	Case Swing Upper Floor out Tilt Front Panel forward FREQ. ERROR. (KHz) Meter Frequency Select Switch Assembly (FREQUENCY MHz Thumbwheels)	c. (1)-(3) d. (1) i. (1)-(3) i. (15)-(17) i. (18)-(20)
BFO/OFF switch	i. (76)-(78)	Case	c. (1)-(3)
EXT MOD connector	i. (79)-(81)	Case Swing Upper Floor out Tilt Front Panel forward FREQ. ERROR (KHz) Meter Frequency Select Switch Assembly (FREQUENCY KHz Thumbwheels)	c. (1)-(3) d. (1) i. (1)-(3) i. (15)-(17) i. (18)-(20)
EXT ACC connector	i. (82)-(84)	Case	c. (1)-(3)
INT MOD OUT connector	i. (85)-(87)	cast'	c. (1)-(3)
1 KHz INT MOD and INT MOD controls	i. (88)-(92)	Case Swing Upper Floor out Tilt Front Panel forward Spectrum Analyzer Assembly Dual Tone Generator	c. (1)-(3) d. (1) i. (1)-(3) i. (4)-(11) i. (12)-(14)

Table 5-13. Disassembly Sequence – Continued

Module to be removed	Module disassembly steps	Modules which must be removed first	Module removal steps
SCOPE IN connector	i. (93)-(94)	Case Disconnect coax cable from SCOPE IN connector	c. (1)-(3) i. (2)
1,5/5/15 KHz control	i. (95)-(99)	Case Swing Upper Floor out Tilt Front Panel forward Spectrum Analyzer Assembly	c. (1)-(3) d. (1) i. (1)-(3) i. (4)-(11)
CAL adjustment	i. (100)-(101)	Case	c. (1)-(3)
Phase Lock Lamps	i. (102)-(109)	Case Swing Upper Floor out Tilt Front Panel forward FREQ. ERROR (KHz) Meter	c. (1)-(3) d. (1) i. (1)-(3) i. (15)-(17)
INPUT LEVEL lamp	i. (110)-(113)	Case Swing Upper Floor out ANT INPUT connector	c. (1) d. (1) i. (2) (24)-(25)
ON lamp	i. (114)-(117)	Case PWR/OFF/BATT Switch	c. (1)-(3) i. (44)-(47)
0 dBm lamp	i. (118)-(121)	Case Speaker	c. (1)-(3) e. (10)-(13)
MM-100 (Multimeter) Circuit Board	j. (5)-(10)	Remove MM-100 case from AN/GRM-114 case MM-100 Composite Assembly	c. (1) j. (1)-(4)

## c. Case Removal.

- (1) Unlock two latches which lock multi-meter case to AN/GRM-114 case. Slide multimeter case off AN/GRM-114 case.
- (2) Remove four Phillips screws and four washers which secure black rectangular frame to four standoffs on rear panel. Remove frame from stand-offs.
- (3) Remove eight Phillips screws and eight flat washers which secure case to rear panel.
- (4) Remove one Phillips screw which secures case to top of front panel.
- (5) Remove one Phillips screw which secures case to bottom of front panel.
- (6) Slide case away from front panel, off AN/GRM-114.

## d. Removal of Assemblies from Upper Floor.

- (1) Remove two Phillips screws (1) and two washers (2) which secure Upper Floor Assembly (3) to frame support members (4) and (129) (figure 5-46). Swing out Upper Floor Assembly.
- (2) Tag and unsolder wires from feed-thru capacitors of Heterodyne Amplifier, 2 Prescaler (5) (figure 5-48).
- (3) Tag and disconnect coax cables from assembly (5) (figure 5-48).
- (4) Remove two Phillips screws (2), two lockwashers (3), and two spacers (4) which secure assembly (5) to Upper Floor (6) (figure 5-48).
- (5) Remove assembly (5) from Upper Floor (6) (figure 5-48).
- (6) Tag and unsolder wires from feed-thru capacitor of 1200-2200 MHz Oscillator (11) (figure 5-48).

- (7) Tag and disconnect coax cables from assembly (11) (figure 5-48).
- (8) Remove two 5/16" Phillips screws (7) and two lockwashers (8) from AGC PCB mounting bracket (9) (figure 5-48).
- (9) Remove bracket (9) with AGC PCB (10) from 1200-2200 MHz Oscillator Assembly (11) (figure 5-48).
- (10) Remove four Phillips screws (1), four lockwashers (36) which secure assembly (11) to Upper Floor (6) (figure 5-48).
- (11) Remove two hex nuts (16), one lockwasher (17), and one ground lug (18) which secure TCXO mounting bracket (15) to TCXO Master Oscillator (13) (figure 5-48).
- (12) Remove TCXO (13) from mounting bracket. (15) (figure 5-48).
- (13) Disconnect Connector (14) from TCXO (13).
- (14) Tag and disconnect coax cable from TCXO (13) (figure 5-48).
- (15) Tag and unsolder wire from feed-thru capacitor of TCXO Output Distribution Amplifier (21) (figure 5-48).
- (16) Tag and disconnect coax cables from assembly (21) (figure 5-48).
- (17) Remove two 1/4" Phillips screws (19), and two lockwashers (20) which secure assembly (21) to Upper Floor (6) (figure 5-48).
- (18) Disconnect mating connector from connector (23) on clock divider (22) (figure 5-48).
- (19) Tag and disconnect coax cables from assembly (22).
- (20) Remove two 1/4" Phillips screws (24), two lockwashers (25), and two flatwashers (26) which secure assembly (22) to Upper Floor (6) (figure 5-48).

e. Removal of Assemblies from Frame Support Members.

- (1) Remove two 3/8" Phillips screw (23) which secure Second Mixer Assembly (24) to frame support member (25) (figure 5-46)
- (2) Remove assembly (24) from frame support member (25) (figure 5-46).
- (3) Unplug mating connector from connector (26) on assembly (24) (figure 5-46).
- (4) Tag and disconnect coax cables from assembly (24) (figure 5-46).
- (5) Remove two Phillips screws (75) and two washers (76) which secure mounting angle (77) to 1200 MHz Diode Switch/High Frequency Multiplier Mixer mounting bracket (30) (figure 5-46).
- (6) Tag and disconnect coax cables from 100 MHz Filter assembly (37) (figure 5-46).
- (7) Tag and unsolder wire from feed-thru capacitor on assembly (37) (figure 5-46).
- (8) Remove two screws (78) and two washers (79) which secure 100 MHz Filter (37) to mounting angle (77).
- (9) Remove assembly (37) from AN/GRM-114.
- (10) Remove one 1/2" Phillips screw (42) and one lockwasher (43) to disconnect frame support member (25) from front panel (44) (figure 5-46).
- (11) Remove one 1/4" Phillips screw (38) and one lockwasher (39), and one 1/2" Phillips screw (40) and one lockwasher (39) which secure Speaker Assembly/Plate Retainer (41) to frame support member (25) (figure 5-46).
- (12) Unsolder wires from speaker.

- (13) Remove Speaker Assembly/Plate Retainer (11) from frame support member (25) (figure 5-46).
  - (14) Tag and (Disconnect coax cables from First Mixer Assembly (45) (figure 5-46).
  - (15) Tag and unsolder wire from feed-thru capacitor on assembly (45) (figure 5-46).
  - (16) Remove three 7/16" Phillips screws (46) which secure assembly (45) to frame support member (25) (figure 5-46).
  - (17) Remove assembly (45) from frame support member (25) (figure 5-46).
  - (18) Use an allen wrench to remove two 5/8" socket head screws (47) and two spacers (48) which hold 1200 MHz Filter/Diode Switch Assembly (49) to mounting bracket (30) (figure 5-46).
  - (19) Tag and disconnect two semi-rigid coax cables from assembly (49) (figure 5-16).
- NOTE
- Use extreme care so as not to kink cables.
- (20) Tag and unsolder wire from feed-thru capacitor on assembly (49) (figure 5-46).
  - (21) Remove two Phillips screws (50) which hold straps for two remaining coax cables.
  - (22) Tag and disconnect two remaining coax cables from assembly (49) (figure 5-16).
  - (23) Remove assembly from AN/GRM-114.
  - (24) Discharge capacitor A1A8C1 (7). Then loosen one slotted screw in capacitor mounting clamp (5). Remove

capacitor from mounting clamp (figure 5-46).

- (25) Remove 7½ A BATT fuse from fuseholder on rear panel of AN/GRM-114.
- (26) Tag and disconnect coax cables from High Frequency Multiplier/Mixer Assembly (51) (figure 5-46).
- (27) Unplug mating connector from connector on assembly (51) (figure 5-46).
- (28) Use an Allen wrench to remove four socket head screws which hold assembly (51) to mounting bracket (30) (figure 5-46).
- (29) Remove assembly (51) from mounting bracket (30) (figure 5-46).

f. Removal of Assemblies from Mother Board.

- (1) Remove two 1/4" Phillips screws (151) and two lockwashers (152) which secure Regulator Power Supply Circuit Board retainer (8) to frame support member (129) (figure 5-46).
- (2) Remove Circuit board retainer (8) from frame support member (129) (figure 5-46).
- (3) Remove Regulator Power Supply PCB (10) from Mother Board (12) (figure 5-46).
- (4) Loosen one Phillips screw (13) on top of standoff (14) which secures VCO PCB retainer (15) to standoff (14) (figure 5-46).
- (5) Move retainer (15) out of the way to allow removal of VCO PCB (16) (figure 5-46).
- (6) Tag and disconnect coax cables from PCB (16) (figure 5-46).
- (7) Remove PCB (16) from Mother Board (12) (figure 5-46).

(8) Tag and disconnect coax cables from High Frequency Phase Lock PCB enclosure (18) (figure 5-46).

(9) Remove five slotted nuts (153) and lockwashers (17) from underside of Mother Board (12), which secure PCB enclosure (18) to Mother Board (12). Remove hex nut from three coax connectors which secure PCB (19) to enclosure (18) (figure 5-46).

(10) Remove PCB enclosure (18) from Mother Board (12). Remove PCB (19) from Mother Board (12) (figure 5-46).

(11) Tag and disconnect coax cable from 79-80 MHz Loop PCB enclosure (20) (figure 5-46).

(12) Remove four slotted nuts (154) and four lockwashers (157) from underside of Mother Board (12), which secure PCB enclosure (20) to Mother Board (12) (figure 5-46). Remove hex nut from coax connector which secures PCB (21) to enclosure (20) (figure 5-46).

(13) Remove PCB enclosure (20) from Mother Board (12). Remove PCB (21) from Mother Board (12) (figure 5-46),

(14) Remove two Phillips screws (72) and two lockwashers (73) which secure 250 kHz I.F. Monitor Audio Circuit Board retainer (74) to Frame Support Member (25).

(15) Remove two 3/8" Phillips screws (27) and two lockwashers (28) which secure 250 kHz I.F. Monitor Audio Circuit Board guide mounting plate (29) to 1200 MHz Diode Switch/High Frequency Multiplier Mixer mounting bracket (30) (figure 5-46).

(16) Remove 250 kHz I.F. Monitor Audio PCB (32) from Mother Board (12) (figure 5-46).

(17) Tag and disconnect coax cables from 1080 MHz Multiplier Amplifier Assembly (33) (figure 5-46).

- (18) Tag and unsolder wire from feed-thru capacitor on assembly.
  - (19) Remove one 1/8" Phillips screw, one 5/32" Phillips screw, and one lock-washer which secure assembly (33) to mounting bracket (34) (figure 5-46).
  - (20) Remove assembly (33) from mounting bracket (34) (figure 5-46).
  - (21) Tag and disconnect coax cables from 1200 MHz Amplifier Assembly (36) (figure 5-46).
  - (22) Tag and unsolder wire from feed-thru capacitor on assembly (36) (figure 5-46).
  - (23) Remove four Phillips screws and four lockwashers from underside of Mother Board (12) which secure assembly (36) to Mother Board (figure 5-46).
  - (24) Remove assembly (36) and mounting bracket (34) from Mother Board (12) (figure 5-46).
  - (25) Tag and disconnect coax cables from High Level Amplifier Assembly (63) (figure 5-46).
  - (26) Tag and unsolder wires from feed-thru capacitors.
  - (27) Remove two 3/8" Phillips screws and two lockwashers from underside of Mother Board (12) which secure High Level Amplifier (63) to Mother Board (figure 5-46).
  - (28) Remove High Level Amplifier (63) from Mother Board (12) (figure 5-46).
  - (29) Remove two 1/4" Phillips screws and two lockwashers from underside of Mother Board (12) which secure static Discharge Protector (35) to Mother Board (figure 5-46).
  - (30) Tag and disconnect coax cables from assembly (35) (figure 5-46).
  - (31) Tag and unsolder wire from feed-thru capacitor.
  - (32) Remove assembly (35) from Mother Board (12) (figure 5-46).
  - (33) Tag and remove coax cables from 108 MHz Band pass Filter Assembly (71) (figure 5-46).
  - (34) Remove four 7/16" Phillips screws, four lockwashers, and four spacers which secure 108 MHz Bandpass Filter (71 ) to underside of mounting bracket (30) (figure 5-46).
  - (35) Remove 108 MHz Bandpass Filter (71) (figure 5-46).
  - (36) Remove two 5/16" Phillips screws (68) and two lockwashers (69) which secure Relay Driver Circuit Board (70) to underside of Mother Board (12) (figure 5-46).
  - (37) Unplug Relay Driver Circuit Board (70) from connector and remove circuit board (figure 5-46).
- g. Removal of Assemblies from Lower Floor.
- (1) Remove two screws (155) and two washers (156) which secure frame support member ( 53) to Front Panel (44) and Rear Panel (58) (figure 5-46).
  - (2) Swing Lower Floor (52) open (figure 5-46).
  - (3) Tag and disconnect coax cables from FM/AM Generator (54) (figure 5-46).
  - (4) Unplug mating connector from bracket mounted connector (141) (figure 5-46).
  - (5) Remove two 1/4" Phillips screws, two lockwashers and two flatwashers from FM/AM Generator (54) (figure 5-46).

- (6) Remove assembly (54) from Lower Floor (52) (figure 5-46).
  - (7) Remove two 1/4" Phillips screws, two lockwashers, and two flat washers which hold 100 MHz Amplifier/108 MHz Mixer Assembly (55) to Lower Floor (52) (figure 5-46).
  - (8) Tag and disconnect coax cables from assembly (55) (figure 5-46).
  - (9) Tag and unsolder wire from feed-thru capacitor.
  - (10) Remove assembly (55) from Lower Floor (52) (figure 5-46).
  - (11) Tag and disconnect coax cables from 120 MHz Receiver Assembly (56) (figure 5-46).
  - (12) Tag and unsolder wires from feed-thru capacitors on assembly (56) (figure 5-46).
  - (13) Remove two 1/4" Phillips screws, four lockwashers and two flat washers which hold assembly (56) to Lower Floor (52) (figure 5-46).
  - (14) Remove assembly (56) from Lower Floor (52) (figure 5-46).
- h. Removal of Assemblies from Rear Panel.
- (1) Loosen two captive screws which secure A1A8A1P1 to A1A8A1J1 (140) on Duty Cycle Regulator Assembly (59) (figure 5-46).
  - (2) Remove four Phillips screws which hold Duty Cycle Regulator (59) to Rear Panel (58) (figure 5-46).
  - (3) Remove Phillips screw and terminal lug at inside bottom of Regulator (59).
  - (4) Remove Duty Cycle Regulator (59) from Rear Panel (58) (figure 5-46).
  - (5) Unscrew semirigid coax hex nut connection from Transmitter Sensor (62) (figure 5-46).
  - (6) Tag and unsolder wire from feed-thru capacitor.
  - (7) Unscrew hex nut connection between 20 dB Pad (61) and Transmitter Sensor Assembly (62) (figure 5-46).
  - (8) Remove Transmitter Sensor (62) (figure 5-46).
  - (9) Remove four 3/8" Phillips screws which secure 20 dB Pad (61) to Rear Panel (58) (figure 5-46).
  - (10) Unscrew hex nut connection between Power Monitor (60) and 20 dB Pad Assembly (61) (figure 5-46).
  - (11) Tag and disconnect coax cables from Power Monitor Assembly (60) (figure 5-46).
  - (12) Remove 20 dB Pad (61) (figure 5-46).
  - (13) Remove Power Monitor (60) from 20 dB Pad (61) (figure 5-46).
  - (14) Remove two 3 3/4" Phillips screws (64) and two flat washers (65) which hold Modified Battery Assembly (66) to Rear Panel (58) (figure 5-46).
  - (15) Unplug 2-pin Molex connector (139) (figure 5-46).
  - (16) Remove Modified Battery Assembly (66) (figure 5-46).
  - (17) Remove four screws, two lockwashers and two ground lugs from Rear Panel (58) which secure transformer mounting bracket and transformer (67) to Rear Panel (58) (figure 5-46),
  - (18) Tag and unsolder wires from transformer (67) (figure 5-46).



- (19) Remove transformer mounting brackets, transformer (67) and one stand-off (figure 5-46).

i. Removal of Assemblies from Front Panel.

- (1) Remove Phillips screws and lockwashers which hold frame support members to Front Panel (44) (figure 5-46).
- (2) Disconnect coax connectors from rear of TRANS/RCVR, 10 MHz REF OUT, SCOPE IN, and ANT INPUT coaxial jacks.
- (3) Tilt top of Front Panel forward to provide better access to rear of Front Panel (44) (figure 5-46).
- (4) Use an Allen wrench to loosen the two socket head screws located in control knobs (108, 109, 112, 115, 116, 117, 118, 121 and 124) (figure 5-46).
- (5) Remove knobs from control shafts.
- (6) Disconnect plug from jack (145) attached to Spectrum Analyzer Assembly (125) (figure 5-46).
- (7) Disconnect coax connector (144) (figure 5-46).
- (8) Remove hex nuts (110, 113, 119, 132, and 134) which secure Spectrum Analyzer Assembly (125) to Front Panel (44) (figure 5-46).
- (9) Remove flatwashers (111, 114, 120, 133, and 135) from control bushings (figure 5-46).
- (10) Remove two hex nuts (143) from screw (126) which secure Spectrum Analyzer Assembly (125) to frame support member (129) (figure 5-46). Let screw (126) washer (127) and spacer (128) remain in Spectrum Analyzer (125).

- (11) Lift Spectrum Analyzer Assembly (125) from AN/GRM-114 (figure 5-46).

- (12) Disconnect fifteen-pin connector A1-A12P1 from Dual Tone Generator PCB (109) (figure 5-47).

- (13) Remove four hex nuts (72) and four lockwashers (73) which secure Dual Tone Generator Assembly (74) to Front Panel (44) (figure 5-47).

- (14) Remove Dual Tone Generator Assembly (74) from Front Panel (44) (figure 5-47).

- (15) Remove two hex nuts and solder lugs from Frequency Error Meter (81) terminals (figure 5-47).

- (16) Remove two screws which hold meter to rear of Front Panel (44) (figure 5-47).

- (17) Remove meter from Front Panel.

- (18) Tag and disconnect two multi-pin plugs from Frequency (MHz) Select Switch Assembly PCB (79) (figure 5-47).

- (19) Remove four hex nuts (75), four lockwashers (76), and four flatwashers (77) which hold Frequency (MHz) Select Switch Assembly (78) to Front Panel (44) (figure 5-47).

- (20) Remove assembly from Front Panel.

- (21) Remove two hex nuts and solder lugs from Deviation (KHz) /WATTS meter (80) terminals (figure 5-47).

- (22) Remove two screws which secure meter to Front Panel (44) (figure 5-47).

- (23) Remove meter from Front Panel.

- (24) Remove hex nut and lockwasher which secure ANT INPUT jack (82) to Front Panel (44) (figure 5-47).
- (25) Remove ANT INPUT jack from Front Panel.
- (26) Use an Allen wrench to loosen socket head screws (83) which secure knob (84) to shaft of DEV/PWR switch shaft (figure 5-47).
- (27) Tag and unsolder wires from DEV/PWR switch wafer terminals.
- (28) Remove hex nut (110) and flat washer which secure DEV/PWR switch to Front Panel (44) (figure 5-47).
- (29) Remove switch and lockwasher from Front Panel.
- (30) Tag and unsolder wires from HI LVL/ $\mu$ V x 100/NORM switch.
- (31) Remove hex nut (113) and flat washer which secure switch to Front Panel (44) (figure 5-47).
- (32) Remove switch and lockwasher from Front Panel.
- (33) Tag and unsolder wires from AUTO/OFF/ZERO, BATT switch.
- (34) Remove hex nut (86) and flat washer which secure switch to Front Panel (44) (figure 5-47).
- (35) Remove switch and lockwasher from Front Panel.
- (36) Use an Allen wrench to loosen two socket head screws (87) in RF LEVEL/BFO INJECTION control knob (88) (figure 5-47).
- (37) Remove knob (88) (figure 5-47).
- (38) Remove two 1/4" Phillips screws from dial/attenuator stop (89) (figure 5-47).
- (39) Remove hex nut (127) and dBm Dial (128) from shaft of Dial Attenuator Assembly (91). Then remove one 1/4" Phillips screw which holds dial index/attenuator ring (90) to Front Panel (44) (figure 5-47).
- (40) Remove dial index/attenuator ring (90) from Front Panel (44) (figure 5-47).
- (41) Disconnect coax connectors from attenuator Assembly (91) (figure 5-47).
- (42) Remove hex nut and lockwasher which secure TRANS/RCVR jack (92) to Front Panel (44) (figure 5-47).
- (43) Remove TRANS/RCVR jack (92) from Front Panel (44) (figure 5-47).
- (44) Make sure two-pin Molex battery connector (139) has been disconnected (figure 5-47).
- (45) Unsolder wires from PWR/OFF/BATT switch (93) at rear of Front Panel (44) (figure 5-47).
- (46) Remove two hex nuts, one washer and three solder lugs which secure switch (93) to Front Panel (44) (figure 5-47).
- (47) Remove switch and spacer from Front Panel.
- (48) Tag and unsolder wires from ZERO/RCVR potentiometer at rear of Front Panel.
- (49) Remove hex nut (94) and flat washer which secure ZERO/RCVR potentiometer to Front Panel (44) (figure 5-47).
- (50) Remove potentiometer and lockwasher from Front Panel.
- (51) Tag and unsolder wires from GEN/RCVR switch at rear of Front Panel (44) (figure 5-47).
- (52) Remove hex nut (95) and flat washer which secure GEN/RCVR switch to Front Panel (44) (figure 5-47).

- (53) Remove switch and lockwasher from Front Panel.
- (54) Tag and unsolder wires from RCVR WIDE/MID/NARROW switch at rear of Front Panel (44) (figure 5-47).
- (55) Remove hex nut (125) and flat washer which secure switch to Front Panel (44) (figure 5-47).
- (56) Remove switch and lockwasher from Front Panel (44) (figure 5-47).
- (57) Remove hex nut from rear of mounting block. Remove hex nut and lockwasher which secure REF OUT jack (96) to Front Panel (44) (figure 5-47).
- (58) Remove REF OUT jack (96) from Front Panel.
- (59) Use an Allen wrench to loosen two socket head screws in SQUELCH control knob (97) and remove knob (97) from control shaft (figure 5-47).
- (60) Tag and unsolder wires from SQUELCH control at rear of Front Panel (44) (figure 5-47).
- (61) Remove hex nut and flat washer which secure control to Front Panel (44) (figure 5-47).
- (62) Remove SQUELCH control and terminal lug from Front Panel.
- (63) Tag and unsolder wires from EXT SPKR jack (98) at rear of Front Panel (44) (figure 5-47).
- (64) Remove hex nut and flat washer which secure EXT SPKR jack (98) to Front Panel (44) (figure 5-47).
- (65) Remove jack and lockwasher from Front Panel.
- (66) Use an Allen wrench to loosen two socket head screws which hold VOL control knob (99) to VOL control shaft. Remove knob (99) (figure 5-47).
- (67) Tag and unsolder wires from VOL control at rear of Front Panel (44) (figure 5-47).
- (68) Remove hex nut and flat washer which secure VOL control to Front Panel (44) (figure 5-47).
- (69) Remove VOL control and lockwasher from Front Panel.
- (70) Tag and unsolder wires from INT MOD/RCVR switch (100) at rear of Front Panel (44) (figure 5-47).
- (71) Remove hex nut and flat washer which secure INT MOD/RCVR switch (100) to Front Panel (44) (figure 5-47).
- (72) Remove switch and lockwasher from Front Panel.
- (73) Tag and unsolder wires from AM/FM switch (101) at rear of Front Panel (44) (figure 5-47).
- (74) Remove hex nut and flat washer which secure AM/FM switch (101) to Front Panel (44) (figure 5-47).
- (75) Remove AM/FM switch and terminal lug from Front Panel.
- (76) Tag and unsolder wires from BFO switch (102) (figure 5-47).
- (77) Remove hex nut and flat washer which secure BFO switch to Front Panel (44) (figure 5-47).
- (78) Remove BFO switch and lockwasher from Front Panel.
- (79) Tag and unsolder wires from EXT MOD jack (103) (figure 5-47).
- (80) Remove hex nut and flat washer which secure EXT MOD jack (103) to Front Panel (44) (figure 5-47).
- (81) Remove jack and lock washer from Front Panel.

- (82) Tag and unsolder wires from EXT ACC jack (104) at rear of Front Panel (44) (figure 5-47).
- (83) Remove hex nut and lockwasher at rear of Front Panel (44) which secure jack to Front Panel (44) (figure 5-47).
- (84) Remove EXT ACC jack from Front Panel.
- (85) Tag and unsolder wires from INT MOD OUT jack (105) at rear of Front Panel (44) (figure 5-47).
- (86) Remove hex nut and lockwasher at rear of Front Panel (44) which secure jack (105) to Front Panel (44) (figure 5-47).
- (87) Remove INT MOD OUT jack from Front Panel.
- (88) Use an Allen wrench to loosen socket head screws which secure INT MOD knob (106) and 1 KHz INT MOD knob (108) to control shafts (figure 5-47).
- (89) Remove knobs (106 and 108) from control shafts.
- (90) Tag and unsolder wires from INT MOD and 1 KHz INT MOD controls at rear of Front Panel (44) (figure 5-47).
- (91) Remove hex nut and flat washer which secure INT MOD controls to Front Panel (44) (figure 5-47).
- (92) Remove INT MOD controls from Front Panel.
- (93) Remove hex nut and lockwasher which secure SCOPE IN jack (107) to Front Panel (44) (figure 5-47).
- (94) Remove SCOPE IN jack (107) from Front Panel.
- (95) Use an Allen wrench to loosen socket head screws in 1.5/5/15 KHz control knob (122) (figure 5-47).
- (96) Remove knob from control shaft.
- (97) Tag and unsolder wires from 1.5/5/15 KHz control at rear of Front Panel (44) (figure 5-47).
- (98) Remove hex nut (112) and flat washer which secure switch to Front Panel (44) (figure 5-47).
- (99) Remove 1.5/5/15 KHz control and lockwasher from Front Panel (44) (figure 5-47).
- (100) Tag and unsolder wires from 10 MHz CAL control (126) (figure 5-47).
- (101) Unscrew control from mounting block at rear of Front Panel (44) (figure 5-47).
- (102) Pull off green lamp cover (146) from left-hand Phase Lock lamp on Front Panel (44) (figure 5-46).
- (103) Use a piece of tape to remove lamp from lamp socket.
- (104) Tag and unsolder wires from lamp socket at rear of Front Panel (44) (figure 5-46).
- (105) Remove lamp socket from rear of Front Panel (44) (figure 5-46).
- (106) Pull off green lamp cover (147) from right-hand Phase Lock lamp on Front Panel (44) (figure 5-46).
- (107) Use a piece of tape to remove lamp from lamp socket.
- (108) Tag and unsolder wires from lamp socket at rear of Front Panel (44) (figure 5-46).
- (109) Remove lamp socket from rear of Front Panel (44) (figure 5-46).
- (110) Pull off green lamp cover (148) from INPUT LEVEL lamp on Front Panel (44) (figure 5-46).
- (111) Use a piece of tape to remove lamp from lamp socket.

- (112) Tag and unsolder wires from lamp socket at rear of Front Panel (44) (figure 5-46).
- (113) Remove lamp socket from rear of Front Panel (44) (figure 5-46).
- (114) Pull off green lamp cover (149) from Power ON lamp on Front Panel (44) (figure 5-46).
- (115) Use a piece of tape to remove lamp from lamp socket.
- (116) Tag and unsolder wires from lamp socket at rear of Front Panel (44) (figure 5-46).
- (117) Remove lamp socket from rear of Front Panel (44) (figure 5-46).
- (118) Pull off amber lamp cover (150) from 0 dBm lamp on Front Panel (44) (figure 5-46).
- (119) Use a piece of tape to remove lamp from lamp socket.
- (120) Tag and unsolder wires from lamp socket at rear of Front Panel.
- (121) Remove lamp socket from rear of Front Panel (44) (figure 5-46).

j. MM-100 (Multimeter) Disassembly.

- (1) Loosen left-hand 1/4-turn fastener which secures metal cover plate to MM-100 accessory compartment. Remove cover plate.
- (2) Remove one 1/4" Phillips screw (1) and one washer (2) which secure bracket (3) to MM-100 case (figure 5-49).
- (3) Loosen 1/4-turn fastener which holds right-hand side of MM-100 Composite Assembly to MM-100 case.
- (4) Separate MM-100 Composite Assembly from MM-100 Case.

- (5) Remove three 1/2" screws (8) which secure Circuit Board (10) to standoffs (9) on Structural Front Panel (11) (figure 5-49).
- (6) Remove two Phillips screws (47) which secure cable retaining plate (48) to bracket (3) (figure 5-49).
- (7) Remove two 7/16" Phillips screws (4), two flat washers (5), and two spacers (6) which secure bracket (3) to Front Panel (7) (figure 5-49).
- (8) Disconnect two connectors (46) from Circuit Board (10) (figure 5-49).
- (9) Tag and unsolder four wires of Cable Assembly (49) from Circuit Board (10) (figure 5-49).
- (10) Remove Cable Assembly (49) from Circuit Board (10) (figure 5-49).

5-12. Reassembly Instructions.

a. General. The following procedures provide a guide for assembling the AN/GRM-114, including all the assemblies herein.

b. Precautions and General Techniques. Reconnect all electrical wiring or cables as identified. Be careful not to damage connector pins when installing mating connectors. When necessary refer to component location diagrams located at the end of the alignment procedures to find referenced connectors, jacks, and potentiometers.

c. Rear Panel Reassembly.

- (1) Install transformer mounting bracket, transformer (67), and two spacers (figure 5-46).
- (2) Attach four screws and two ground lugs to Rear Panel (58) which hold transformer mounting bracket and transformer (67) to Rear Panel. Solder wires to transformer (figure 5-46).
- (3) Install Battery Cover (6) (figure 5-46).

- (4) Install Modified Battery mechanical assembly (66) (figure 5-46).
  - (5) Plug in battery connector (figure 5-46).
  - (6) Attach two 3-3/4" Phillips screws (64) and two flat washer (65) which hold Modified Battery mechanical assembly (66) to Rear Panel (58) (figure 5-46).
  - (7) Install 20 dB pad (61) (figure 5-46).
  - (8) Attach four 3/8" Phillips screws which hold 20 dB pad (61) to Rear Panel (58) (figure 5-46).
  - (9) Attach hex nut connection between 20 dB pad (61) and Transmitter Sensor (62) (figure 5-46).
  - (10) Install Duty Cycle Regulator (59) to Rear Panel (58) (figure 5-46).
  - (11) Attach four 3/8" Phillips screws which hold Duty Cycle Regulator (59) to Rear Panel (58). Then plug A1A8A1P1 into A1A8A1J1 (140) and tighten two captive screws. Install Phillips screw and terminal lug at inside bottom of regulator (figure 5-46).
  - (12) Install Transmitter sensor (62) (figure 5-46).
  - (13) Solder wire to feed-through capacitor.
  - (14) Attach semi-rigid coax to Transmitter Sensor (62) (figure 5-46).
  - (15) Install Power Monitor (60) to 20 dB pad (61) (figure 5-46).
  - (16) Attach hex nut connection between Power Monitor (60) to 20 dB pad (61) (figure 5-46).
  - (17) Attach tagged coax cables to Power Monitor (60) (figure 5-46).
- d. Mother Board Reassembly.
- (1) Install 79-80 MHz Loop Circuit Bead (21) to Mother Board (12) (figure 5-46).
  - (2) Install 79-80 MHz Loop Circuit Board enclosure (20) to Mother Board (12) (figure 5-46).
  - (3) Install hex nut to coax connector which holds PCB (21) to enclosure (20).
  - (4) Install tagged coax cable to 79-80 MHz Loop Circuit Board enclosure (20) (figure 5-46).
  - (5) Attach four slotted four lockwashers (157) to underside of Mother Board (12), which secure 79-80 MHz Loop Circuit Board enclosure (20) to Mother Board (figure 5-46).
  - (6) Install High Frequency Phase Lock Circuit Board (19) to Mother Board (12) (figure 5-46).
  - (7) Install High Frequency Phase Lock Circuit Board enclosure (18) to Mother Board (12) (figure 5-46).
  - (8) Install three hex nuts and lockwashers to coax connectors which secure PCB (19) to enclosure (18) (figure 5-46).
  - (9) Attach five slotted nuts (153) and lockwashers (17) to underside of Mother Board (12), which secure enclosure (18) to Mother Board (figure 5-46).
  - (10) Install tagged coax cables to enclosure (18) (figure 5-46).
  - (11) Install tagged coax cables to VCO Tuner Circuit Board (16) (figure 5-46).
  - (12) Install VCO Tuner Circuit Board (16) to Mother Board (12) (figure 5-46).

- (13) Secure VCO PCB retainer (15) to standoff (14) with one Phillips screw (13) (figure 5-46).
- (14) Install Regulator and Power Supply Circuit Board (10) to Mother Board (12) (figure 5-46).
- (15) Install Circuit Board retainer (8) to frame support member (129) (figure 5-46).
- (16) Attach two 1/4" Phillips screws and two lockwashers which secure Regulator and Power Supply Circuit Board retainer (8) to frame support member (129) (figure 5-46).
- (17) install Static Discharge Protector (35) to Mother Board (12) (figure 5-46).
- (18) Install tagged coax cables to Static Discharge Protector (35) (figure 5-46).
- (19) Attach two 1/4" Phillips screws and two lockwashers to underside of Mother Board (12) which secure Static Discharge Protector (35) to Mother Board (figure 5-46).
- (20) Install mounting bracket (34) to Mother Board (12) (figure 5-46).
- (21) Install 1200 MHz Amplifier (36) to Mother Board (12) (figure 5-46).
- (22) Attach four Phillips screws and four lockwashers to underside of Mother Board (12) which secure 1200 MHz Amplifier (36) to Mother Board. Solder wire to feed-through capacitor on assembly (figure 5-46).
- (23) Attach RF cables to 1200 MHz Amplifier (36) (figure 5-46).
- (24) Solder wire to 1080 MHz Multiplier Amplifier (33) feed-through capacitor (figure 5-46).
- (25) Install 1080 MHz Multiplier Ampl. (33) to mounting bracket (34) (figure 5-46).
- (26) Attach one 1/8" Phillips screw, and one 5/32" Phillips screw and one lockwasher which secure 1080 MHz Multiplier Amplifier (33) to mounting bracket (34) (figure 5-46).
- (27) Attach tagged coax cables to 1080 MHz Multiplier Amplifier (33) (figure 5-46).
- (28) Install High Level Amplifier (63) to Mother Board (12) (figure 5-46).
- (29) Attach two 3/8" Phillips screws and two lockwashers to underside of Mother Board (12) which secure High Level Amplifier (63) to Mother Board (figure 5-46).
- (30) Solder wires to feed-through capacitors.
- (31) Install tagged coax cables to High Level Amplifier (63) (figure 5-46).
- (32) Install 250 kHz I.F. Monitor Audio Circuit Board (32) (figure 5-46).
- (33) Attach two 3/8" Phillips screws (27) and two lockwashers (28) which secure 250 kHz I.F. Monitor Audio Circuit Board guide mounting plate (29) through 1200 MHz Diode Switch/High Frequency Multiplier/Mixer mounting bracket (30) to lower frame support member (136) (figure 5-46).
- (34) Attach 250 kHz I.F. Monitor Audio Circuit Board retainer (74) with two Phillips screws (72) and lockwashers (73) to upper frame support member (25) (figure 5-46).
- (35) Plug in Relay Driver Circuit Board (70) to connector and install Circuit Board (figure 5-46).
- (36) Attach two 5/16" Phillips screws (68) and two lockwashers (69) which hold Relay Driver Circuit Board (70) to underside of Mother Board (12) (figure 5-46).
- (37) Install 108 MHz Bandpass Filter (71) (figure 5-46).

(38) Attach four 7/16" Phillips screws, four lockwashers, and four spacers which hold 108 MHz Bandpass Filter (71) to underside of 1200 MHz Diode Switch/High Frequency Multiplier/Mixer mounting bracket (30) (figure 5-46).

(39) Attach tagged coax cables to 108 MHz Band pass Filter (71) (figure 5-46).

e. Frame Support Member Reassembly.

(1) Install High Frequency Multiplier/Mixer (51) to mounting bracket (30) (figure 5-46).

(2) Use an Allen wrench to attach four socket head screws which hold the High Frequency Multiplier/Mixer (51) to 1200 MHz Diode Switch/High Frequency Multiplier/Mixer mounting bracket (30) (figure 5-46).

NOTE

Install Battery Fuse on back of Rear Panel.

(3) Plug mating connector into connector on assembly (51) (figure 5-46).

(4) Solder wires to assembly (51) (figure 5-46).

(5) Install tagged coax cables to assembly (51) (figure 5-46).

(6) Insert capacitor (7) through mounting clamp (5). Tighten slotted screw in mounting clamp (figure 5-46).

(7) Install 1200 MHz Diode Switch (49) to mounting bracket (30) (figure 5-46).

(8) Solder wire to feed-through capacitor.

(9) Install tagged coax cables.

(10) Attach two Phillips screws (50) which hold straps for tagged coax cables (figure 5-46).

(11) Install tagged coax cables to 1200 MHz Diode Switch (49) (figure 5-46).

(12) Use an Allen wrench to attach two 5/8" socket head screws (47) and two spacers (48) which hold 1200 MHz Diode Switch (49) to 1200 MHz Diode Switch/High Frequency Multiplier/Mixer mounting bracket (30) (figure 5-46).

(13) Install First Mixer (45) to frame support member (25) (figure 5-46).

(14) Attach three 7/16" Phillips screws (46) which secure First Mixer (45) to frame support member (25) (figure 5-46).

(15) Solder wire to feed-through capacitor.

(16) Install tagged coax cables to First Mixer (45) (figure 5-46).

(17) Install speaker assembly/plate retainer (41) to frame support member (25) (figure 5-46).

(18) Solder wires to speaker assembly.

(19) Attach one 1/4" Phillips screw (38) and one lockwasher (39), and one 1/2" Phillips screw (40) and one lockwasher (39) which secure speaker assembly/plate retainer (41) to frame support member (25) (figure 5-46).

(20) Attach 100 MHz Filter (37) to mounting angle (77) with two screws (78) and two washers (79) (figure 5-46).

(21) Solder wire to feed-through capacitor on assembly (37) (figure 5-46).

(22) Install tagged coax cables to assembly (37) (figure 5-46).

(23) Attach mounting angle (77) to 1200 MHz Diode Switch/High Frequency Multiplier/Mixer mounting bracket (30) with two screws (75) and lockwashers (76) (figure 5-46).



- (24) Install tagged coax cables to Second Mixer Assembly (24) (figure 5-46).
- (25) Plug in circular mating connector (26).
- (26) Install Second Mixer Assembly (24) to frame support member (25) (figure 5-46).
- (27) Attach two 3/8" Phillips screws (23) which secure Second Mixer Assembly (24) to frame support member (25) (figure 5-46).

f. Front Panel Reassembly.

- (1) Attach socket head screws with Allen wrench to KHz control (122). Attach control (122) (figure 5-47).
- (2) Use an Allen wrench to attach socket head screws to EXT V/DIV Control (118). Attach control (118), hex nut (119), and washer (120) (figure 5-46).
- (3) Use an Allen wrench to attach socket head screws to EXT V/DIV Vernier Control (117). Attach control (117) (figure 5-46).
- (4) Attach hex nut, washer and SCOPE IN connector (107) (figure 5-47).
- (5) Tighten hex nut.
- (6) Attach tagged coax cable to SCOPE IN connector (107) at rear of Front Panel (44) (figure 5-47).
- (7) Install assembly and washer to rear of Front Panel (44) (figure 5-47).
- (8) Solder tagged wires to assembly at rear of Front Panel (44) (figure 5-47).
- (9) Attach hex nut and washer to Front Panel (44) (figure 5-47).
- (10) Use an Allen wrench to attach two socket head screws to each of two knobs (106), (108) at INT MOD/OFF control (111) (figure 5-47).

- (11) Install INT MOD OFF connector (105) (figure 5-47).
- (12) Attach hex nut to rear of Front Panel (44) which holds INT MOD OUT connector (105) to Front Panel (figure 5-47).
- (13) Install assembly and hex nut.
- (14) Tighten hex nut at rear of Front Panel (44) (figure 5-47).
- (15) Install EXT ACC connector (104) through front of Front Panel (44) (figure 5-47).
- (16) Attach hex nut to rear of Front Panel (44) (figure 5-47).
- (17) Solder tagged wires to assembly for EXT ACC connector (104) at rear of Front Panel (44) (figure 5-47).
- (18) Attach flat washer and hex nut to Front Panel (44) at EXT MOD connector (103) (figure 5-47).
- (19) Install assembly and lockwasher to rear of Front Panel.
- (20) Solder tagged wires to assembly at rear of Front Panel (44) (figure 5-47).
- (21) Install BFO/OFF switch assembly (102), hex nut, and washer to Front Panel (44) (figure 5-47).
- (22) Attach hex nut to rear of Front Panel (44).
- (23) Solder tagged wires to switch assembly at rear of Front Panel (44) (figure 5-47).
- (24) Attach hex nut and flat washer.
- (25) Attach hex nut to Front Panel (44) at BFO/OFF switch (102) (figure 5-47).
- (26) Install AM/FM switch assembly (101), hex nut, and washer to Front Panel (44) (figure 5-47).

- (27) Attach hex nut to rear of Front Panel (44) (figure 5-47).
- (28) Solder tagged wires to switch assembly at rear of Front Panel (44) (figure 5-47).
- (29) Attach hex nut and flat washer.
- (30) Attach hex nut to Front Panel (44) at AM/FM switch (101) (figure 5-47).
- (31) Install INT MOD/RCVR switch assembly (100), hex nut, and washer to Front Panel (44) (figure 5-47).
- (32) Attach hex nut to rear of Front Panel (44) (figure 5-47).
- (33) Solder tagged wires to switch assembly at rear of Front Panel (44) (figure 5-47).
- (34) Attach hex nut and flat washer.
- (35) Attach hex nut to Front Panel (44) at INT MOD/RCVR switch (100) (figure 5-47).
- (36) Install VOL control assembly (99) to Front Panel (44) (figure 5-47).
- (37) Solder tagged wires to assembly at rear of Front Panel (44) (figure 5-47).
- (38) Attach hex nut and flat washer.
- (39) Attach knob (99) (figure 5-47).
- (40) Use an Allen wrench to attach two 1/8" socket head screws which hold VOL control knob (99) to Front Panel (44) (figure 5-47).
- (41) Install EXT SPKR connector assembly (98) with lockwasher to rear of Front Panel (44) (figure 5-47).
- (42) Solder tagged wires to assembly at rear of Front Panel (44) (figure 5-47).
- (43) Attach hex nut and washer to Front Panel (44) at EXT SPKR connector (98) (figure 5-47).
- (44) Install SQUELCH control assembly and lug to Front Panel (44) (figure 5-47).
- (45) Solder tagged wires to rear of Front Panel (44) (figure 5-47).
- (46) Attach hex nut and flat washer.
- (47) Attach knob (97) (figure 5-47).
- (48) Use an Allen wrench to attach two 1/8" socket head screws which hold SQUELCH knob (97) to Front Panel (44) (figure 5-47).
- (49) Install REF OUT connector (96) (figure 5-47).
- (50) Attach CAL mounting block and hex nut to rear of Front Panel (44) (figure 5-47).
- (51) Attach tagged coax cable to rear of Front Panel (44) at REF OUT connector (96) (figure 5-47).
- (52) Attach CAL control (126) to thick portion of threaded mounting block and solder tagged wires to rear of control (figure 5-47).
- (53) Attach RCVR WIDE/MID/NARROW switch (125), hex nut, and washer to Front Panel (44) (figure 5-47).
- (54) Solder tagged wires to rear of switch.
- (55) Solder wire to ground lug on back of Front Panel (44) (figure 5-47).
- (56) Attach hex nut and flat washer to RCVR WIDE/MID/NARROW switch (125) on Front Panel (44) (figure 5-47).
- (57) Attach GEN/RCVR switch (95) lockwasher, hex nut, and flat washer to Front Panel (44) (figure 5-47).
- (58) Solder wires to rear of switch.
- (59) Solder wire to ground lug on back of Front Panel (44) (figure 5-47).

- (60) Attach hex nut, flat washer and lock-washer to GEN/RCVR switch (95) on Front Panel (44) (figure 5-47).
- (61) Install ZERO/RCVR control (94) to rear of Front Panel (44) (figure, 5-47).
- (62) Solder wire, to control at rear of Front Panel (44) (figure 5-47).
- (63) Attach hex nut, flat washer, and lockwasher to ZERO/RCVR adjustment (94) on Front Panel (44) (figure 5-47)
- (64) Install PWR/OFF/BATT switch assembly (93) to mounting screws on rear of Front Panel (44) (figure 5-47).
- (65) Attach hex nut and washer to one mounting screw; hex nut, lockwasher, three terminal lugs, washer and spacer on other screw.
- (65) Solder wires to PWR/OFF/BATT switch (93) at rear of Front Panel (44) (figure 5-47).
- (67) Install TRANS/RCVR connector (92) to Front Panel (44) (figure 5-47).
- (68) Attach hex nut to rear of Front Panel (44) which holds TRANS/RCVR connector (92) to Front Panel (figure 5 - 4 7 ) .
- (69) Connect coax connectors to Dial Attenuator Assembly (91), then install Assembly to Front Panel (44) (figure 5-47).
- (70) Install dial index/attenuator ring (90) to Front Panel (44) (figure 5-47).
- (71) Attach one 1/4" Phillips screw which holds dial index/attenuator ring (90) to Front Panel (44) (figure 5-47).
- (72) Secure dBm Dial (128) to shaft of Dial Attenuator Assembly (91) with hex nut (127) (figure 5-47).
- (73) Secure dial/attenuator stop (89) to dBm Dial (128) with two 1/4" Phillips screws (figure 5-47).
- (74) Attach knob (88) (figure 5-47).
- (75) Use an Allen wrench to attach two - 1/4" socket head screws (87) to BFO INJECTION knob (88) (figure 5-47),
- (76) Attach AUTO/OFF/ZERO, BATT switch (86), hex nut, and washer (figure 5-47).
- (77) Solder wires to rear of switch.
- (78) Attach hex nut and flat washer to AUTO/OFF/ZERO, BATT switch (86) on Front Panel (44) (figure 5-47).
- (79) Attach HI LVL/ $\mu$ V x 100/NORM switch (85), lockwasher, hex nut, and flat washer (figure 5-47).
- (80) Solder tagged wires to rear of switch.
- (81) Solder wire to ground lug on back of Front Panel (44) (figure 5-47).
- (82) Install terminal lug to shaft of HI LVL/ $\mu$ V x 100/NORM switch (85). Insert shaft through rear of Front Panel (figure 5-47).
- (83) Attach hex nut and flat washer to HI LVL/ $\mu$ V x 100/NORM switch (85) on Front Panel (44) (figure 5-47).
- (84) Attach hex nut, flat washer and lock-washer to DEV/PWR control on Front Panel (44) (figure 5-47).
- (85) Attach DEV/PWR knob (84) (figure 5-47). Use an Allen wrench to tighten two 1/8" socket head screws which hold DEV/PWR knob (84) to Front Panel (44).
- (86) Install ANT INPUT connector (82) to Front Panel (44) (figure 5-47).

- (87) Attach tagged coax cable to rear of connector.
- (88) Attach hex nut to rear of Front Panel (44) which holds ANT INPUT connector (82) to Front Panel (figure 5-47).
- (89) Install Frequency Select Switch (78) to Front Panel (44) (figure 5-47).
- (90) Attach four hex nuts (75), four lockwashers (76), and four flat washers (77) which hold switch mechanical assembly (78) to Front Panel (44). Connect two multi-pin plugs to PCB (79) (figure 5-47).
- (91) Install DEVIATION (KHz) /WATTS meter (80) to Front Panel (44) (figure 5-47).
- (92) Attach two screws which hold DEVIATION (KHz)/WATTS meter (80) to rear of Front Panel (44). Install terminal lugs on rear of meter with two hex nuts (figure 5-47).
- (93) Install FREQ ERROR (KHz) meter (81) to Front Panel (44) (figure 5-47).
- (94) Attach two screws which hold FREQ ERROR (KHz) meter (81) to rear of Front Panel (44) (figure 5-47).
- (95) Install terminal lugs on rear of meter with two hex nuts.
- (96) Install Modulation Freq. Hz (Dual Tone Generator) switch assembly (74) to Front Panel (44). Install connector to bottom rear of PCB (109) (figure 5-47).
- (97) Attach four hex nuts (72) and four lockwashers (73) which hold switch mechanical assembly (74) to Front Panel (44) (figure 5-47).
- (98) Secure left-hand phase-lock lamp socket (146) to rear of Front Panel (44) (figure 5-46).
- (99) Solder tagged wires to lamp socket.
- (100) Secure lamp cover to Front Panel (44) (figure 5-46).
- (101) Secure right-hand phase-lock lamp socket (147) to rear of Front Panel (44) (figure 5-46).
- (102) Solder tagged wires to lamp socket.
- (103) Secure lamp cover to Front Panel (44) (figure 5-46).
- (104) Secure INPUT LEVEL lamp socket (148) to rear of Front Panel (44) (figure 5-46).
- (105) Solder tagged wires to lamp socket.
- (106) Secure lamp cover to Front Panel (44) (figure 5-46).
- (107) Secure Power ON lamp socket (149) to rear of Front Panel (44) (figure 5-46).
- (108) Solder tagged wires to lamp socket.
- (109) Secure lamp cover to Front Panel (44) (figure 5-46).
- (110) Secure 0 dBm lamp socket (150) to rear of Front Panel (44) (figure 5-46).
- (111) Solder tagged wires to lamp socket.
- (112) Secure lamp cover to Front Panel (44) (figure 5-46).
- (113) Attach coax cables to TRANS/RCVR connector (92), 10 MHz REF OUT connector (96), ANT INPUT connector (82), and SCOPE IN connector (107) (figure 5-47).
- (114) Attach one 1/2" Phillips screw (42) and one lockwasher (43) to secure frame support member (25) to Front Panel (44) (figure 5-46).
- (115) Attach Phillips screws and lockwashers which hold frame support members to Front Panel (44) (figure 5-46).

g. Spectrum Analyzer Reassembly.

- (1) Install Spectrum Analyzer Assembly (125) to top left frame support member (129) and Front Panel (44) (figure 5-46).
- (2) Attach Spectrum Analyzer Assembly (125) to frame support member (129) with two hex nuts (143) and one lockwasher on one screw (126). Install connectors at (144) and (145) (figure 5-47).
- (3) Attach two screws (130), two lockwashers (131) that hold top left frame support member (129) to Front Panel (44). Tighten frame support member (129) to Front Panel (44) (figure 5-46).
- (4) Attach socket head screws with Allen wrench to INTENSITY control (124). Attach control (124), one hex nut (134), and one washer (135) (figure 5-46).
- (5) Attach socket head screws with Alien wrench to FOCUS control (121). Attach control (121) one hex nut (132) and one washer (133) (figure 5-46).
- (6) Attach socket head screws with Allen wrench to VERT control (115). Attach control (figure 5-46).
- (7) Attach socket head screws with Allen wrench to ANALY DISPR/OFF control (116). Attach control (116) (figure 5-46).
- (8) Install control (112) (figure 5-46).
- (9) Attach socket head screws with. Allen wrench to HORIZ control (112) (figure 5-46).
- (10) Attach socket head screws to SWEEP control (109). Attach control (109), hex nut (110) and washer (111) (figure 5-46).

- (11) Attach socket head screws with Allen wrench to SWEEP Vernier control (108). Attach control (108) (figure 5-46).
- (12) Attach hex nut (113) and washer (114) (figure 5-46) to AC/DC/OFF switch on Front Panel (44) (figure 5-47).

h. Lower Floor Reassembly.

- (1) Install 120 MHz Receiver (56) to Lower Floor (52) (figure 5-46).
- (2) Attach two 1/4" Phillips screws, four lockwashers, and two flat washers which hold 120 MHz Receiver (56) to Lower Floor (52) (figure 5-46).
- (3) Install tagged coax cables to 120 MHz Receiver (56). Install circular connector (142) to mating connector (figure 5-46).
- (4) Install tagged coax cables to 100 MHz Amplifier/108 MHz Mixer (55) (figure 5-46).
- (5) Install 100 MHz Amplifier/108 MHz Mixer (55) to Lower Floor (52) (figure 5-46).
- (6) Attach two 1/4" Phillips screws, two lockwashers, and two flat washers which hold 100 MHz Amplifier/108 MHz Mixer (55) to Lower Floor (52) (figure 5-46).
- (7) Install tagged coax cables to FM/AM Generator (54). Install circular connector to mating connector (141) (figure 5-46).
- (8) Attach two 1/4" Phillips screws, two lockwashers and two flat washers which hold FM/AM Generator (54) to Lower Floor (52) (figure 5-46).
- (9) Close Lower Floor (52) (figure 5-46).

(10) Attach two screws (155) and two washers (156) which secure frame support member (53) to Front Panel (44) and Rear Panel (58) (figure 5-46).

i. Upper Floor Reassembly.

(1) Attach two 1/4" Phillips screws (24), two lockwashers (25), and two flat washers (26) which secure Clock Divider mechanical assembly (22) to Upper Floor (6) (figure 5-48).

(2) Install tagged coax cables. Install mating connector to connector (23) (figure 5-48).

(3) Attach two 1/4" Phillips screws (19) and two lockwashers (20) which secure Master Oscillator Output Distribution Amplifier (21) to Upper Floor (6) (figure 5-48).

(4) Install tagged coax cables and solder wire to feed-through at Master Oscillator Output Distribution Amplifier (21) (figure 5-48).

(5) install TCXO Master Oscillator (13) to mounting bracket (15) (figure 5-48).

(6) Attach two hex nuts (16), one lockwasher (17), and one ground lug (18) which secure Master Oscillator mounting bracket (15) to TCXO Master Oscillator (13) (figure 5-48).

(7) Attach two 5/16" Phillips screws which secure Master oscillator mounting bracket (15) to the Upper Floor (6) (figure 5-48).

(8) Install tagged coax cable to TCXO Master Oscillator (13). Plug in tube socket (14) to TCXO Master Oscillator (13) (figure 5-48).

(9) Install 1200-2200 MHz Oscillator mechanical assembly (11) to Upper Floor (6) (figure 5-48).

(10) Attach four Phillips screws (1) and four lockwashers (36), which secure 1200-2200 MHz Oscillator mechanical assembly (11) to Upper Floor (6) (figure 5-48).

(11) Attach tagged coax cables to 1200-2200 MHz Oscillator mechanical assembly (11) (figure 5-48).

(12) Install AGC mounting bracket (9) with AGC Circuit Board (10) to 1200-2200 MHz oscillator mechanical assembly (11) (figure 5-48).

(13) Attach two 5/16" Phillips screws (7) and two lockwashers (8) to AGC mounting bracket (9) (figure 5-48).

(14) Attach all of the tagged coax cables necessary to the AGC Circuit Board (10) (figure 5-48).

(15) Solder two tagged wires to feed-through on 1200-2200 MHz Oscillator assembly (11); one wire from AGC Circuit Board (10), the other wire from bracket mounted connector (30) (figure 5-48).

(16) Install Heterodyne Amplifier ,2 Prescaler mechanical assembly (5) to Upper Floor (6) (figure 5-48).

(17) Attach two Phillips screws (2), two lockwashers (3), two spacers (4), which secure Heterodyne Amplifier ,2 Prescaler mechanical assembly (5) to Upper Floor (6) (figure 5-48).

(18) Install tagged coax cables and solder wires to feed-through capacitors at Heterodyne Amplifier ,2 Prescaler mechanical assembly (5) (figure 5-48).

(19) Attach two Phillips screws (1) and two washers (2) which secure Upper Floor Assembly (3) to frame support members (4) and (129) (figure 5-46).

j. Case Reassembly.

- (1) Attach case to Front Panel of AN/GRM-114.
- (2) Attach one Phillips screw which secures case to bottom of Front Panel.
- (3) Attach one Phillips screw which secures case to top of Front Panel.
- (4) Attach eight Phillips screws and eight flatwashers which secure case to Rear Panel.
- (5) Attach four Phillips screws and four washers which secure black rectangular frame to four spacers on Rear Panel. Attach black rectangular frame to four spacers.

k. MM-100 (Multimeter) Reassembly.

- (1) Attach cable assembly (49) to PCB Assembly (10) by soldering four wires to PCB Assembly (figure 5-49).
- (2) Attach two connectors (46) to Circuit Board (10) (figure 5-49).
- (3) Attach cable retaining plate (48) to bracket (3) with two Phillips screws (47) (figure 5-49).
- (4) Attach Circuit Board (10) to stand-offs (9) of Structural Front Panel (11) with three 1/2" screws (8) (figure 5-49).
- (5) Attach bracket (3) to Front Panel (7) with two spacers (6), two flat washers (5), and two 7/16" Phillips screws (4) (figure 5-49).
- (6) Attach bracket (3) to MM-100 case with one 1/4" Phillips screw (1) and one washer (2) (figure 5-49).
- (7) Tighten 1/4-turn fastener which holds right-hand side of MM-100 Composite Assembly to MM-100 case.

(8) Attach metal cover plate to MM-100 accessory compartment by tightening 1/4-turn fastener.

(9) Slide MM-100 cover onto AN/GRM-114 cover, then secure by locking latches.

5-13. Preparation for reshipment or limited storage.

Refer to paragraph 1 of chapter 2 for packaging instructions, and to paragraph 12 of chapter 1 for Warranty Information.

5-14. Demolition to prevent enemy use.

a. Authority for Demolition. Demolition of the AN/GRM-114 will be accomplished only upon the order of the commander. The destruction procedure outlined in paragraph b. will be used to prevent further use of the equipment.

h. Methods of destruction. Any of the methods of destruction given below may be used. The time available will be a major determining factor for the method used. The tactical situation will determine in what manner the destruction order will be carried out.

(1) Smash. Smash the controls and connections of the AN/GRM-114 with the heaviest tool available if time does not permit removing the AN/GRM-114 from its case; use sledges, axes, hammers, crowbars, and any other heavy tools available to smash the interior of the AN/GRM-114.

(2) Cut. Cut cabling and wiring. Cut all cables in a number of places; use axes, machetes, and similar tools. If time permits, slash the interior wiring.

(3) Burn. Burn as much of the AN/GRM-114 as is flammable; use gasoline, oil, flame-thrower, or similar tools. Burn instruction literature first. Pour gasoline on the cut cables and ignite it. Use a flame-thrower to burn the spare parts or pour gasoline on the spares and ignite it. Use incendiary grenades to complete destruction of the equipment interiors.

**WARNING**

Be extremely careful with explosives and incendiary devices. Use these items only when the need is urgent.

(4) Explode. Use explosives to complete demolition or to cause maximum destruction when time does not permit demolition by other means. Powder charges, fragmentation gre-

nades, or incendiary grenades may be used. Place the explosive charges against the front panel of the AN/GRM-114 to cause maximum destruction; the second most effective location is against the top of the case of the AN/GRM-114. Incendiary grenades usually are most effective if destruction of small parts and wiring is desired.

(5) Dispose. Bury or scatter the destroyed parts in slit trenches, foxholes, or throw them into streams.

<http://www.pdf-tools.com>



<http://www.pdf-tools.com>

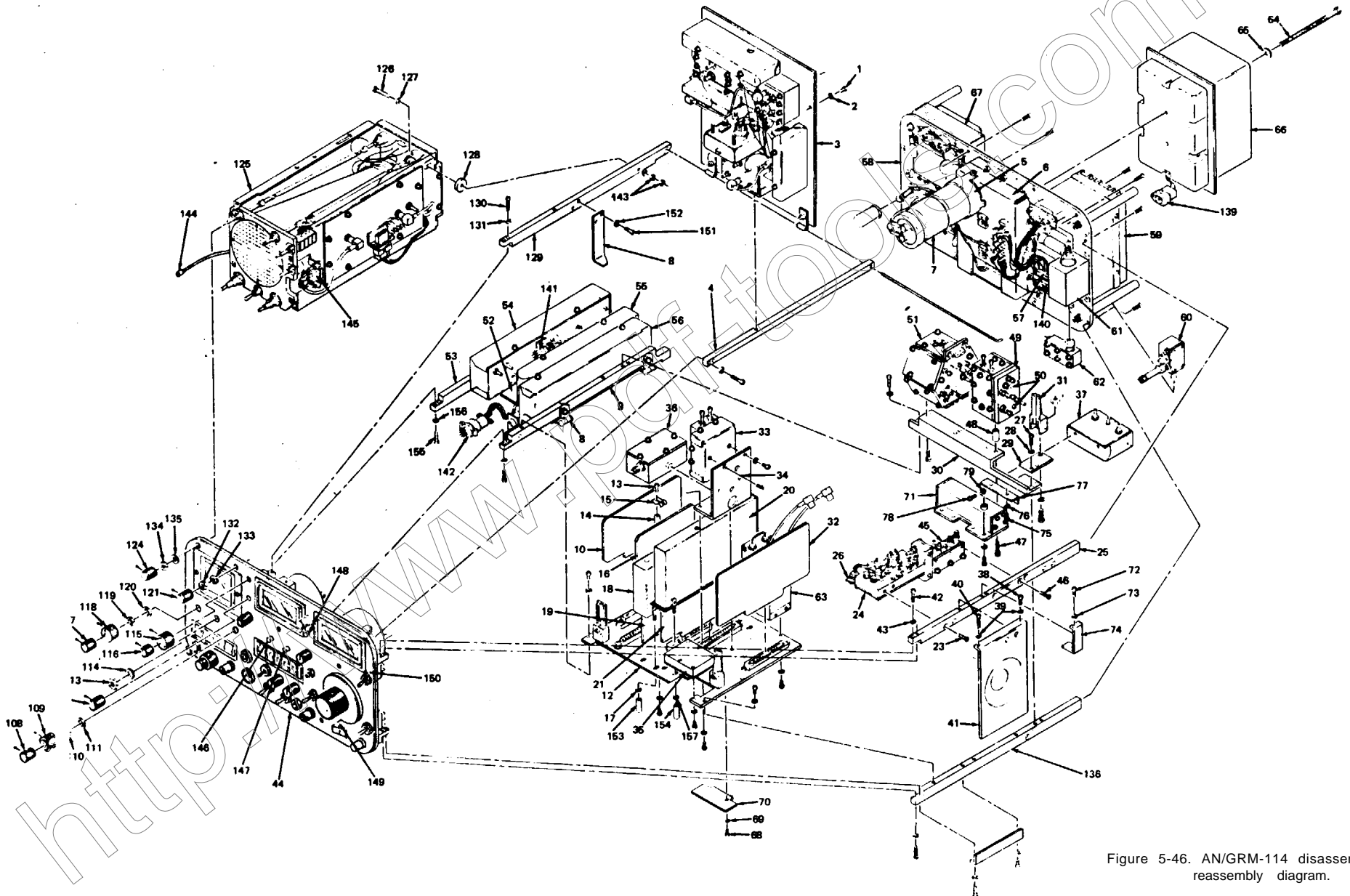


Figure 5-46. AN/GRM-114 disassembly reassembly diagram.

<http://www.pdf-tools.com>

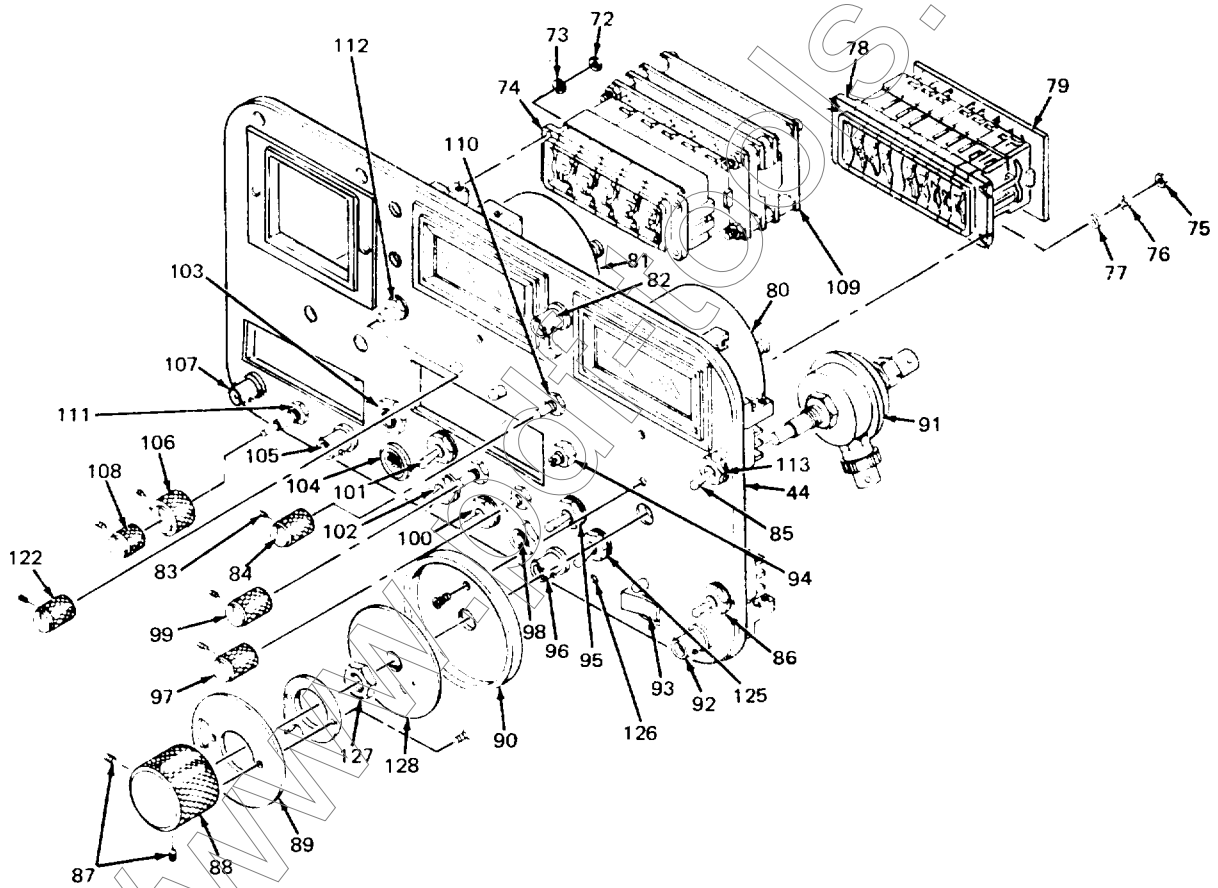


Figure 5-47. Front panel disassembly/reassembly diagram.

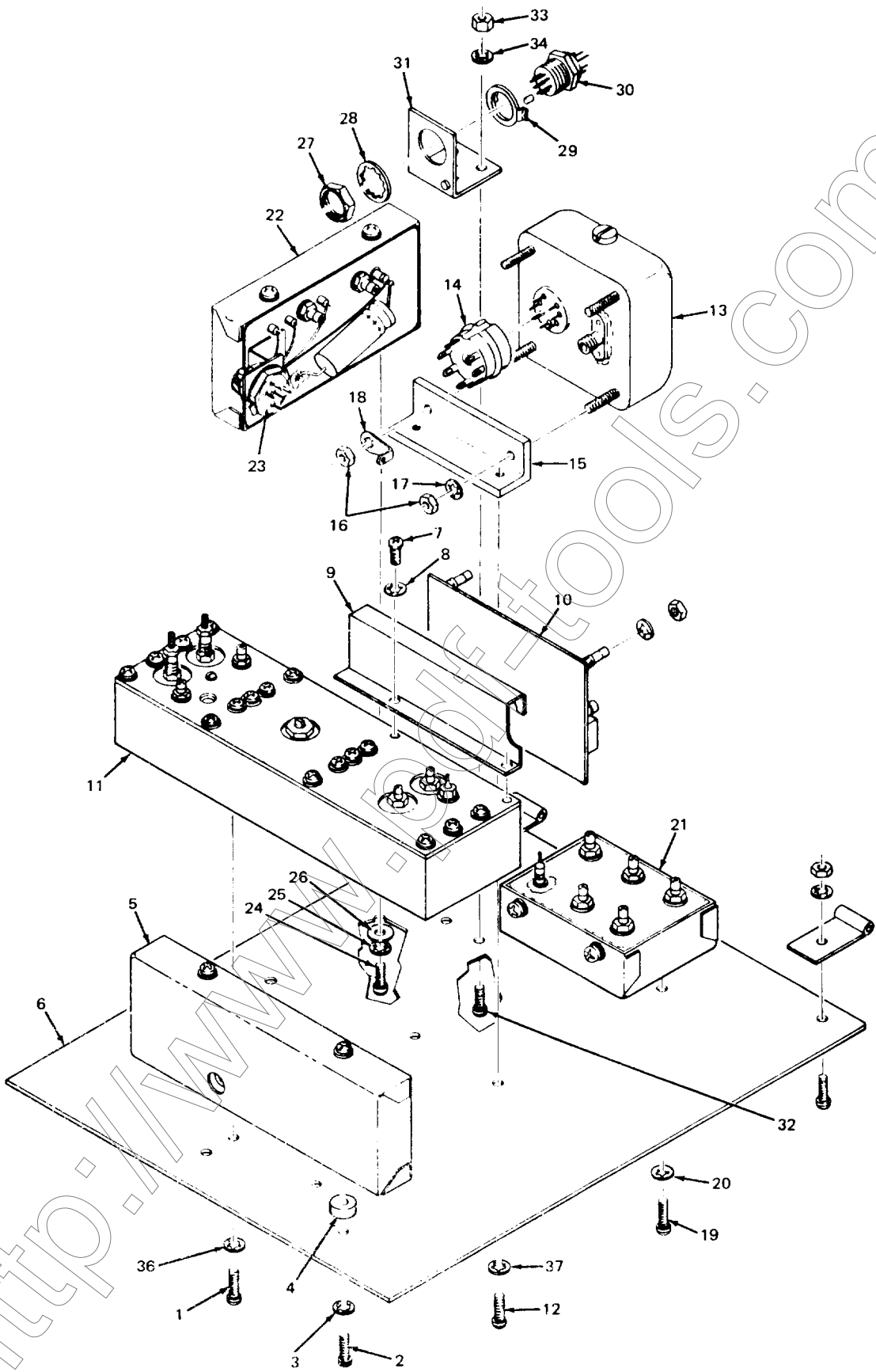


Figure 5-48. Upper floor disassembly/reassembly diagram.

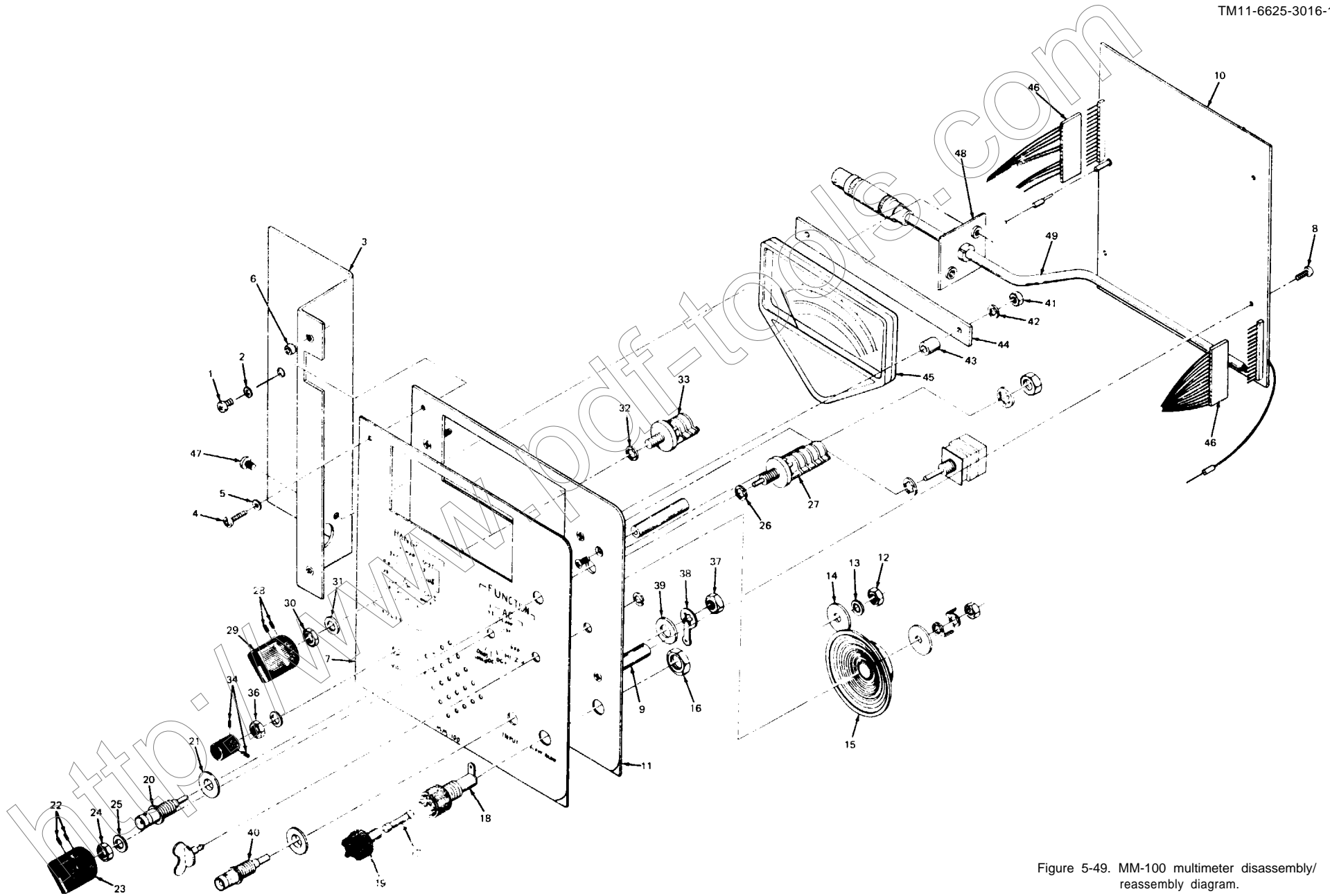


Figure 5-49. MM-100 multimeter disassembly/reassembly diagram.

<http://www.pdf-tools.com>

## CHAPTER 6

SCHEMATIC DIAGRAMS

---

This chapter contains the schematic diagrams for Test Set AN/GRM-114. They are located in back of the manual.

<http://www.pdf-tools.com>



<http://www.pdf-tools.com>

**APPENDIX A****REFERENCES**

DA Pam 310-4	<b>Index of Technical Publications.</b>
TB 43-180	<b>Calibration Requirements for the Maintenance of Army Materiel.</b>
TB 385-4	<b>Safety Precautions for Maintenance of Electrical/Electronic Equipment.</b>
TM 11-6625-400-12	<b>Operator's and Organizational Maintenance Manual for Meter, Modulation ME-57/U.</b>
TM 11-6625-446-15	<b>Operator's, Organizational, Direct Support, General Support and Depot Maintenance Manual: Wattmeter AN/URM-120.</b>
TM 11-6625-1576-15	<b>Organizational, Direct Support, General Support and Depot Maintenance Manual for Distortion Analyzer, Hewlett-Packard Models 333A and 334A.</b>
TM 11-6625-2736-14	<b>Operator's, Organizational, Direct Support and General Support Maintenance Manual: Oscilloscope OS-262(P)/U (NSN 6625-01-007-9416).</b>
TM 11-6625-2953-14	<b>Operator's, Organizational, Direct Support and General Support Maintenance Manual: Multimeter AN/USM-451 (NSN 6625-01-060-6804).</b>
TM 38-750	<b>The Army Maintenance Management System (TAMMS).</b>
TM 740-90-1	<b>Administrative Storage of Equipment.</b>
TM 750-244-2	<b>Procedures for Destruction of Electronics Materiel to Prevent Enemy Use (Electronics Command).</b>

<http://www.pdf-tools.com>

## APPENDIX B

### COMPONENTS OF END ITEM LIST

---

#### Section I. INTRODUCTION

##### B-1. SCOPE

The integral components of and basic issue items for the AN/GRM-114 arc listed in table 1-4 to help you inventory items required for safe and efficient operation.

<http://www.pdf-tools.com>

<http://www.pdf-tools.com>

## APPENDIX D MAINTENANCE ALLOCATION CHART

### SECTION I. INTRODUCTION

1. General. This maintenance allocation chart provides a summary of the maintenance operations for Test Set AN/GRM-114. It authorizes categories of maintenance for specific maintenance functions on repairable items and components and the tools and equipment required to perform each function. This MAC appendix may be used as an aid in planning maintenance operations.

2. Maintenance Functions. Maintenance functions will be limited to and defined as follows:

- a. Inspect. To determine the serviceability of an item by comparing its physical, mechanical, and electrical characteristics with established standards through examination.
- b. Test. To verify serviceability and to detect incipient failure by measuring the mechanical or electrical characteristics of an item and comparing these characteristics with prescribed standards.
- c. Service. Operations required periodically to keep an item in proper operating condition such as to clean, to preserve, to paint and to lubricate.
- d. Adjust. Maintain within prescribed limits by bringing into proper or exact position, or by setting the operation characteristics to the specified parameters.
- e. Align. Maintain within prescribed limits by bringing into proper or exact position, or by setting the operating characteristics to the specified parameters.
- f. Calibrate. To determine the corrections to be made in the readings of instruments or test equipment used in precise measurement. Consists of the comparison of two instruments one which is a certified standard of known accuracy, to detect and adjust any discrepancy in the accuracy of the instrument being compared with the certified standard.
- g. Install. To set up for use in an operational environment such as an encampment, site or vehicle.
- h. Replace. To replace unserviceable items with serviceable like items.
- i. Repair. To restore an item to serviceable condition through correction of a specific failure or unserviceable condition. This function includes, but is not limited to welding, grinding, riveting, straightening, and replacement of parts other than the trial and error replacement of running spare type items such as fuses and indicators.
- j. Overhaul. Normally, the highest degree of maintenance performed by the Army in order to minimize time and assure that work in process is consistent with quality and economy of operation. It consists of that maintenance necessary to restore an item to completely serviceable condition as prescribed by maintenance standards in technical publications for each item to like new, zero mileage, or zero hour condition.
- k. Rebuild. The highest degree of material maintenance. It consists of restoring equipment as nearly as possible to likenew condition in accordance with original manufacturing standards. Rebuild is the highest degree of material maintenance applied to Army equipment. Rebuild reduces to zero the hours the equipment, or component thereof, has been in use.

3. Explanation of Format of Section II, Maintenance Allocation Chart. The add columns in Section II are as follows:

- a. Column 1, Group Number. Column 1 lists group numbers, the purpose of which is to identify components, assemblies, subassemblies, and modules with the next higher assembly.
- b. Column 2, Component/Assembly. Column 2 lists the noun names of components, as-

semblies, subassemblies, and modules on which maintenance is authorized.

c. Column 3, Maintenance Functions. Column 3 lists the functions to be performed on the item listed in column 2.

d. Column 4, Maintenance Category. Column 4 specifies, by the listing of a "worktime" figure in the appropriate subcolumn(s), the lowest level of maintenance authorized to perform the function listed in column 3. This figure represents the active time required to perform that maintenance function at the indicated category of maintenance. If the number of complexity of the tasks within the listed maintenance function vary at different maintenance categories, appropriate "worktime" figures will be shown for each category. The number of man-hours specified by the "worktime" figure represents the average time required to restore an item (assembly, subassembly, component, module, end item or system) to a serviceable condition under typical field operating conditions. This time includes preparation time, troubleshooting time and quality assurance/quality control time in addition to the time required to perform the specific tasks identified for the maintenance functions authorized in the maintenance allocation chart. Subcolumns of column 4 are as follows:

- |                  |                   |
|------------------|-------------------|
| C Operator/crew  | O Organizational  |
| F Direct Support | H General Support |
| D Depot          | Maintenance       |

e. Column 5, Tools and Equipment. Column 5 specifies, by code, those tool sets and test equipment required to perform the designated function. The numbers appearing in this column refer to specific tools and test equipment which are identified in Section III.

4. Explanation of Format of Section III, Tool and Test Equipment Requirements. The columns in Section III are as follows:

a. Tools or Test Equipment Reference Code. The numbers in this column coincide with the numbers used in the Tools and Equipment column of the applicable tool or test equipment for the maintenance functions.

b. Maintenance Category. The codes in this column indicate the maintenance category normally allocated the tool or test equipment.

c. Nomenclature. This column lists tools, test, and maintenance functions.

d. National/NATO Stock Number. This column lists the National/NATO stock number or the specific tool or test equipment.

e. Tool Number. This column lists the manufacturer's part number of the tool followed by the Federal Support Code for Manufacturers (5 digit) in parentheses.

SECTION II MAINTENANCE ALLOCATION CHART  
FOR  
TEST SET, RADIO AN/GRM-114

(1) GROUP NUMBER	(2) COMPONENT/ASSEMBLY	(3) MAINTENANCE FUNCTION	(4) MAINTENANCE CATEGORY					(5) TOOLS AND EQPT.	(6) REMARKS
			C	O	F	H	D		
00	TEST SET, RADIO AN/GRM-114 (P/N 7002-2364-302)	Inspect Install Replace Test Test Adjust Adjust Repair		0.2 0.2 0.2		4.0		Visual 24 24 1 thru 27 1 thru 43 1 thru 27 1 thru 43	
01	MECH ASSY, COMPOSITE A1 (P/N 7003-2364-101)	Test Repair				1.5	4.0 1.0	1 thru 27 24	A thru L A thru M
0101	MECH ASSY, FRONT PANEL A1A1 (P/N 7005-2377-700)	Inspect Replace				0.1 1.2		Visual 24	M
010101	WIRE HARNESS ASSY, FRONT PANEL A1A1A1 (P/N 7007-2377-800)	Inspect Replace				0.1	0.5	Visual 24	M
0102	MECH ASSY, UPPER FLOOR A1A3 (P/N 7006-2364-400)	Inspect Replace				0.1 0.5		Visual 24	A
010201	MECH ASSY, TCXO OSCILLATOR A1A3U1 (P/N 5850-000-010)	Inspect Test Replace				0.1 0.3 0.2		Visual 2,4 24	
010202	MECH ASSY, HET AMP 2 PRESCALER A1A3A1 (P/N 7024-2322-500)	Inspect Test Test Replace				0.1 0.7	1.5	Visual 3,4,14,24 1,3,4,8,24, 32 24	C
01020201	PCB ASSY, HET AMP 2 PRESCALER A1A3A1A1 (P/N 7010-2368-400)	Test					1.5 0.3	1,3,4,8,24, 32 24	C,M
010203	MECH ASSY, 1200-2200 MHZ OSCILLATOR A1A3A2 (P/N 7025-2356-000)	Inspect Test Test Replace				0.2 2.5	3.0	Visual 1,3,4,8,24 1,3,4,8,24, 28 24	C
01020301	PCB ASSY, 1200-2200 MHZ OSCILLATOR A1A3A2A1 (P/N 7010-2355-900)	Test Repair					2.5 0.5	1,3,4,8,24, 28 24	C,E,M
010204	PCB ASSY, AGC SYSTEM A1A3A3 (P/N 7010-2368-600)	Inspect Test Test Replace				0.1 0.7	1.0	Visual 1,8,17,24,36 1,8,17,24,36 24	
010205	MECH ASSY, CLOCK DIVIDER A1A3A4 (P/N 7026-2321-700)	Inspect Test Test Replace				0.1 0.5	1.0	Visual 1,2,4,24 1,2,4,8,24 24	
01020501	PCB ASSY, CLOCK DIVIDER A1A3A4A1 (P/N 7010-2309-300)	Test Repair					1.0 0.5	1,2,4,8,24 24	M
010206	MECH ASSY, TCXO OUTPUT DISTRIBUTION AMPLIFIER A1A3A5 (P/N 7014-2362-000)	Inspect Test Test Replace				0.1 0.4	0.8	Visual 1,24 1,4,7,8,24, 41 24	
01020601	PCB ASSY, TCXO OUTPUT DISTRIBUTION AMPLIFIER A1A3A5A1 (P/N 7010-2361-000)	Test Replace					0.8 0.5	1,4,7,8,24, 24 24	M
0103	MECH ASSY, TRANSMITTER SENSOR A1A4 (P/N 7005-2375-000)	Inspect Test Replace Replace				0.1 2.0		Visual 2,3,4,7,8, 20,24 3,4,7,8,20, 24,25,31,34, 37 24	



SECTION II MAINTENANCE ALLOCATION CHART  
FOR  
TEST SET, RADIO, AN/GRM-114

(1) GROUP NUMBER	(2) COMPONENT ASSEMBLY	(3) MAINTENANCE FUNCTION	(4) MAINTENANCE CATEGORY					(5) TOOLS AND EQPT.	(6) REMARKS
			C	O	F	H	D		
0104	MECH ASSY, 100 MHZ BANDPASS FILTER A1A5 (P/N 7018-2340-200)	Inspect Test Test Replace				0.1 0.5 0.2	0.5	Visual 3,14,24 3,4,14,24 24	E
0105	MECH ASSY, 1200 MHZ AMPLIFIER A1A6 (P/N 7014-2355-400)	Inspect Test				0.2 0.5		Visual 3,9,14,24	
010501	PCB ASSY, 1200 MHZ AMPLIFIER A1A6A1 (P/N 7010-2354-900)	Replace Test				0.5		24	G,H
0106	MECH ASSY, STATIC DISCHARGE PROTECTIVE A1A7 (P/N 7022-2360-200)	Inspect Test Test Replace				0.2 0.4 0.3	0.6	Visual 3,7,8,14,24 3,4,7,8,14, 24	H
0107	MECH ASSY, REAR PANEL A1A8 (P/N 7005-2338-001)	Inspect Test Replace				0.1 0.5 0.5		Visual 4,9,24 24	M
010701	MECH ASSY, DUTY CYCLE REGULATOR A1A8A1 (P/N 7023-2338-400)	Inspect Test Test Replace Repair				0.2 1.0 0.2	2.0	Visual 4,9,13,24 4,9,13,24,28 24	I
01070101	PCB ASSY, TORIUM MOUNTING A1A8A1A1 (P/N 7010-2334-900)	Test Replace					3.0 2.0	1,4,9,13,24, 28	I
0107010101	PCB ASSY, DUTY CYCLE REGULATOR A1A8A1A1A1 (P/N 7010-2309-000)	Test Repair					2.0 0.5	1,4,9,13,24, 28	I,M
0108	PCB ASSY, HIGH FREQUENCY PHASELOCK A1A9 (P/N 7010-2349-300)	Inspect Test Test Replace				0.2 1.5	3.0	Visual 1,3,4,21,24 1,3,4,21,24, 28,39	C,J
0109	PCB ASSY, 79-80 MHZ LOOP A1A10 (P/N 7010-2342-400)	Inspect Test Test Replace				0.1 0.8	1.5	Visual 1,2,4,14,16, 24	
010901	PCB ASSY, VCO TUNER A1A11 (P/N 7010-2342-300)	Inspect Test Test Replace				0.2 0.8		1,2,4,14,16, 24,28,39 24	
01090101	PCB ASSY, VCO TUNER A1A11 (P/N 7010-2342-300)	Inspect Test Test Replace				0.2 0.8		Visual 1,3,4,14,17, 24	B
0109010101	PCB ASSY, VCO TUNER A1A11 (P/N 7010-2342-300)	Inspect Test Test Replace				0.2 0.8		1,3,4,14,17, 24,28 24	
01011	MECH ASSY, DUAL TONE GENERATOR A1A12 (P/N 7005-2375-300)	Inspect Test Test Replace				0.2 0.7	1.5	Visual 1,2,4,5,16, 18,24	
0101101	PCB ASSY, NO. 1 DUAL TONE GENERATOR A1A12A1 (P/N 7010-2374-600)	Test Repair					1.5 0.7	1,2,4,5,8, 16,18,24 24	M
0101102	PCB ASSY, NO. 2 DUAL TONE GENERATOR A1A12A2 (P/N 7010-2374-900)	Test Repair					1.5 0.5	1,2,4,5,8, 16,18,24 24	M

D - 4

SECTION II MAINTENANCE ALLOCATION CHART  
FOR  
TEST SET, RADIO AN/GRM-114

(1) GROUP NUMBER	(2) COMPONENT/ASSEMBLY	(3) MAINTENANCE FUNCTION	(4) MAINTENANCE CATEGORY					(5) TOOLS AND EQPT.	(6) REMARKS
			C	O	F	H	D		
0101103	PCB ASSY, NO. 3 DUAL GENERATOR A1A12A3 (P/N 7010-2375-200)	Test					1.5	1,2,4,5,8, 16,18,24, 24	M
		Repair					0.5	24	
01012	PCB ASSY, 250 KHZ I.F. MONITOR AUDIO A1A13 (P/N 7010-2357-300)	Inspect					0.2	Visual	
		Test					1.5	1,4,7,11,24	
		Test					2.5	1,4,7,11,24, 28,40	
		Replace					0.2	24	
01013	PCB ASSY, REGULATOR AND POWER SUPPLY A1A14 (P/N 7010-2367-201)	Inspect					0.2	Visual	
		Test					0.7	4,9,10,12,24	
		Test					1.0	4,9,10,12, 24,28,29	
		Replace					0.2	24	
01014	MECH ASSY, 1080 MHZ MULTIPLIER AMPLIFIER A1A15 (P/N 7048-2351-600)	Inspect					0.3	Visual	
		Test					0.5	3,14,24	
		Test					0.8	3,4,7,14,24, 29	
		Replace					0.5	24	
0101401	PCB ASSY, 1080 MHZ MULTIPLIER AMPLIFIER A1A15A1 (P/N 7010-2351-300)	Test					0.8	3,4,7,14,24, 29	
		Repair					0.3	24	M
01015	MECH ASSY, 1200 MHZ DIODE SWITCH A1A16 (P/N 7013-2329-700)	Inspect					0.2	Visual	
		Test					0.7	3,4,24	
		Test					0.8	3,4,8,24,32	
		Replace					0.4	24	G,H
01016	MECH ASSY, POWER MONITOR A1A17 (P/N 7005-2373-700)	Inspect					0.2	Visual	
		Test					0.7	3,4,7,8,14, 15,16,24	I
		Test					0.9	3,4,7,8,14, 15,16,24,31	
		Replace					0.3	34,35 24	M
01017	MECH ASSY, SPECTRUM ANALYZER A1A18 (P/N 7029-2362-600)	Inspect					0.3	Visual	
		Test					1.0	4,6,7,16,24	
		Test					4.0	1,4,6,7,16, 24,28,30	
		Repair					0.7	24	
0101701	MECH ASSY, SPECTRUM ANALYZER, MODULE NO. 1 A1A1A1 (P/N 7030-2363-200)	Test					4.0	4,6,7,16,24, 28	
		Replace					0.3	24	
010170101	PCB ASSY, NO. 1 SPECTRUM ANALYZER A1A18A1A1 (P/N 7010-2359-300)	Test					4.0	1,4,6,7,16, 24,28	M
		Repair					0.2	24	
0101702	PCB ASSY, SCOPE INVERTER A1A18A2 (P/N 7010-2362-400)	Test					0.5	4,24,30	
		Replace					0.6	24	
0101703	MECH ASSY, SPECTRUM ANALYZER MODULE NO. 2 A1A18A3 (P/N 7030-2363-300)	Test					4.0	1,4,6,7,16, 24,28	
		Replace					0.3	24	
010170301	PCB ASSY, NO. 2 SPECTRUM ANALYZER A1A18A3A1 (P/N 7010-2359-400)	Test					4.0	1,4,6,7,16, 24,28	
		Repair					0.2	24	M
0101704	PCB ASSY, SCOPE MAIN A1A18A4 (P/N 7010-2362-500)	Test					4.0	1,4,6,7,16, 24,28	
		Replace					0.2	24	
0101705	MECH ASSY, SPECTRUM ANALYZER FRONT PLATE A1A18A5 (P/N 7028-2366-900)	Inspect					0.1	Visual	
		Replace					1.0	24	
010170501	MECH ASSY, HORIZONTAL SWEEP SWITCH A1A18A5A1 (P/N 7013-2366-700)	Test					0.2	4,24	
		Repair					0.5	24	M

SECTION II MAINTENANCE ALLOCATION CHART  
FOR  
TEST SET, RADIO AN/GRM-114

(1) GROUP NUMBER	(2) COMPONENT, ASSEMBLY	(3) MAINTENANCE FUNCTION	(4) MAINTENANCE CATEGORY					(5) TOOLS AND EQPT.	(6) REMARKS
			C	O	F	H	D		
010170502	MECH ASSY, VERTICAL GAIN SWITCH A1A18A5A2 (P/N 7013-2366-800)	Test Replace					0.2 0.5	4,24 24	
010170503	WIRE HARNESS ASSY, SPECTRUM ANALYZER A1A18A5A3 (P/N 7007-2364-600)	Test Repair					0.4 0.4	4,24 24	M
01018	MECH ASSY, FIRST MIXER A1A19 (P/N 7005-2373-300)	Inspect Test  Test  Replace Repair				0.1 0.5    0.3 1.0	Visual 3,4,7,14,15, 16,19,20,24 3,4,7,14,15, 16,19,20,24, 28 24 24		G,H
01019	MECH ASSY, SECOND MIXER A1A20 (P/N 7017-2346-200)	Inspect Test Test Test  Replace				0.2 0.7    0.3	Visual 3,14,19,24 3,4,14,19, 24,28 24		G,H
01020	MECH ASSY, 100 MHZ FILTER A1A21 (P/N 7018-2359-100)	Inspect Test Test  Replace				0.1 0.3   0.2	Visual 3,14,24 3,4,7,8,14, 24 24		E
0102001	PCB ASSY, 100 MHZ FILTER A1A21A1 (P/N 7010-2330-300)	Test  Repair					0.3 0.4	3,4,7,8,14, 24 24	E,M
01021	COAX CABLE ASSY A1A22 (P/N 6042-2645-5XX)	Inspect Test Repair				0.5 0.3 0.3	Visual 4,24 24		M
01022	MECH ASSY, BATTERY MODIFIED A1A23 (P/N 7005-7624-500)	Inspect Test Replace				0.1 0.2 0.2	Visual 4 24		
01023	MECH ASSY, LOWER FLOOR A1A24 (P/N 7005-2349-201)	Inspect Replace Repair				0.1 0.5 1.0	Visual 24 24		D
0102301	MECH ASSY, 100 MHZ AMPLIFIER/108 MHZ MIXER A1A24A1 (P/N 7017-2321-900)	Inspect Test Test  Repair				0.2 0.5   0.3	Visual 3,14,24 3,7,8,14,24, 32,42 24		F,K,L,M
010230101	PCB ASSY, 100 MHZ AMPLIFIER/108 MIXER A1A24A1A1 (P/N 7010-2309-500)	Test  Repair					1.0 0.5	3,4,7,8,14, 24,32,42 24	F,K,L,M
0102302	MECH ASSY, 120 MHZ RECEIVER A1A24A2 (P/N 7027-2348-300)	Inspect Test  Test  Repair				0.2 1.0    0.3	Visual 2,3,4,7,14, 16,24 1,3,4,7,14, 16,24,28,42 24		H,M
010230201	PCB ASSY, 120 MHZ RECEIVER A1A24A2A1 (P/N 7010-2348-200)	Test  Repair					1.5 0.5	1,3,4,7,14, 16,24,28,42 24	H,M
0102303	MECH ASSY, FM/AM GENERATOR A1A24A3 (P/N 7005-2376-200)	Inspect Test  Test  Replace				0.2 0.7    0.3	Visual 3,4,7,14,16, 24 1,3,6,7,8, 14,16,24,42 24		
010230301	PCB ASSY, FM/AM GENERATOR A1A24A3A1 (P/N 7010-2376-100)	Test  Repair					1.0 0.5	1,3,4,6,7,8, 14,16,24,42 24	M

SECTION II MAINTENANCE ALLOCATION CHART  
FOR  
TEST SET, RADIO AN/GRM-114

(1) GROUP NUMBER	(2) COMPONENT/ASSEMBLY	(3) MAINTENANCE FUNCTION	(4) MAINTENANCE CATEGORY					(5) TOOLS AND EQPT.	(6) REMARKS
			C	O	F	H	D		
01024	PCB ASSY, RELAY DRIVER A1A25 (P/N 7010-2373-100)	Inspect Test Test Replace				0.1 0.2 0.1	0.4	Visual 4,24 4,24 24	
01025	MECH ASSY, HIGH FREQUENCY MULTI/MIXER A1A26 (P/N 7015-2309-700)	Inspect Test Test Replace				0.3 0.8 1.2 0.4	1.2	Visual 3,8,14,21, 23,24 3,4,8,14,21, 22,23,24,28, 29 24	C,J
0102501	PCB ASSY, HIGH FREQUENCY MULTI/MIXER A1A26A1 (P/N 7010-2310-100)	Test Repair					1.2 0.5	3,4,8,14,21, 22,23,23,28, 29 24	C,J,M
01026	MECH ASSY, FREQUENCY SELECT SWITCH A1A27 (P/N 7013-2343-300)	Inspect Replace				0.4 0.8		Visual 24	
01027	MECH ASSY, HIGH LEVEL AMPLIFIER A1A28 (P/N 7005-2372-500)	Inspect Test Test Replace				0.2 1.0 0.5	1.5	Visual 3,4,6,8,14, 19,24 3,4,6,8,14, 19,24,33,35 24	
0102701	PCB ASSY, NO. 2 HIGH LEVEL AMPLIFIER A1A28A1 (P/N 7010-2372-400)	Test Repair					1.5 0.7	3,4,6,8,14, 19,24,33,35 24	M
0102702	PCB ASSY, NO. 2 HIGH LEVEL AMPLIFIER A1A28A2 (P/N 7010-2372-100)	Test Repair					1.5 0.7	3,4,6,8,14, 19,24,33,35 24	M
02	CASE ASSEMBLY MM-100 A2 (P/N 7019-2372-100)	Inspect Install Replace Test Adjust Replace Repair				0.2 0.1 0.1 1.5 1.5 0.2	0.5	Visual 24 24 1,3,4,5,6,8, 16,24 1,2,4,5,6,8, 16,24 24	
0201	COMPOSITE ASSY MM-100 A2A1 (P/N 7003-2380-000)	Test Replace Repair				1.5 0.2	0.5	1,2,4,5,6,8, 16,24 24	
020101	PCB ASSY MM-100 A2A1A1 (P/N 7010-2380-300)	Test Replace					1.5 0.5	1,2,4,5,6,8, 16,24,43 24	
02010101	CABLE ASSY, INTERCONNECT MM-100 A2A1A1A1 (P/N 6046-2379-900)	Inspect Test Repair				0.2 0.5 0.5		Visual 4,24 24	M
020102	MECH ASSY, FRONT PANEL MM-100 A2A1A2 (P/N 7005-2380-400)	Inspect Replace				0.1 1.0		Visual 24	

SECTION III TOOL AND TEST EQUIPMENT REQUIREMENTS  
FOR  
TEST SET, RADIO AN/GRM-114

TOOL OR TEST EQUIPMENT REF CODE	MAINTENANCE CATEGORY	NOMENCLATURE	NATIONAL NATO STOCK NUMBER	TOOL NUMBER
1	H,D	OSCILLOSCOPE OS-262(P)/U	6625-01-007-9416	
2	H,D	FREQUENCY COUNTER TD-1225A	6625-01-103-2958	
3	H,D	SPECTRUM ANALYZER IP-1216/U PLUG-IN RF TUNER PL-1400/U PLUG-IN IF PL-1388/U	6625-00-424-4370 6625-00-422-4314 6625-00-431-9339	
4	H,D	DIGITAL MULTIMETER AN/USM-451	6625-01-060-6804	
5	H,D	DISTORTION ANALYZER AN/URM-184A	6625-00-802-8718	
6	H,D	FUNCTION GENERATOR SG-1133/U	6625-01-028-4989	
7	H,D	SIGNAL GENERATOR, RF AN/USM-308(V)1/U	6625-00-442-3470	
8	H,D	TRIPLE OUTPUT POWER SUPPLY, LAMBDA LPT-7202FM (80103)		
9	H,D	POWER SUPPLY, LAMBDA LK351FM (80103)		
10	H,D	WATTMETER AN/URM-120	6625-00-813-8430	
11	H,D	MODULATION METER ME-57/U	6625-00-647-3737	
12	H,D	MODULATED POWER SOURCE-SAGE 243C		
13	H,D	COMP ASSY, BATTERY LOAD BOX IFR 1003-9801-600 (51190)		
14	H,D	TEST LEAD BNC TO SMB (2) IFR 6050-0032-400 (51190)		
15	H,D	TEST LEAD BNC TO SMA (2) IFR 6050-0092-400 (51190)		
16	H,D	TEST LEAD BNC TO BNC (2) IFR 6050-0522-400 (51190)		
17	H,C	CONNECTOR, SMB TEE IFR 2200-0250-100 (51190)		
18	H,D	CONNECTOR, BNC TEE IFR 2105-1410-900 (51190)		
19	H,D	ADAPTER, SMB JACK TO JACK IFR 2123-0000-016 (51190)		
20	H,D	ADAPTER, SMA JACK TO JACK IFR 2200-0110-100 (51190)		
21	H,D	HIGH FREQUENCY MULTIPLIER/MIXER SNIFFER IFR 6500-9801-700 (51190)		
22	H,D	EXTENDER CABLE (9 PIN) IFR 6046-9801-800 (51190)		
23	H,D	TEST LEAD SMB TO SMB (2) IFR 6050-0042-220 (51190)		
24	O,H,D	TOOL KIT, ELECTRONIC EQUIPMENT TK-100/G	5180-00-605-0079	
25	H,D	CONNECTOR, BNC TO N (2) IFR		
26	H,D	MODIFIED 1/4 INCH NUT DRIVER IFR		
27	H,D	CONNECTOR, SMA TEE IFR		
28	D	TEST SET, RADIO AN/GRM-114		
29	D	VARIABLE ATTENUATOR, TEXSCAN RA-5J (230-42)		
30	D	HIGHT VOLTAGE PROBE, CALIF. INSTRUMENT HV-30 (12897)		
31	D	VSWR BRIDGE, WILTRON 60-N50 (87807)		
32	D	SWEEP SIGNAL GENERATOR, WAVETEK 2002 (23338)		
33	D	TRACKING GENERATOR SG-1125/U	6625-00-185-4802	
34	D	50Ω TERMINATION IFR 2650-0010-200 (51190)		
35	D	R.F. POWER METER WITH POWER DETECTOR HEAD 42BD (04901) 41-41A (04901)		
36	D	COMP ASSY, AGC MONITOR METER IFR 7003-9801-500 (51190)		
37	D	Resistor, 390KΩ, 1/4 W IFR 4702-0394-003 (51190)		
38	D	PCB ASSY EXTENDER, 79-80 MHZ LOOP IFR 7010-9801-200 (51190)		

SECTION III TOOL AND TEST EQUIPMENT REQUIREMENTS  
 FOR  
 TEST SET, RADIO AN/GRM-114

TM 11-6625-3016-14

TOOL OR TEST EQUIPMENT REF CODE	MAINTENANCE CATEGORY	NOMENCLATURE	NATIONAL/NATO STOCK NUMBER	TOOL NUMBER
39	D	PCB ASSY EXTENDER, REG AND PWR SUPPLY IFR 7010-9801-300 (51190)		
40	D	PCB ASSY EXTENDER, 250 KHZ I.F. MONITOR IFR 7010-9801-400 (51190)		
41	D	RESISTOR, 470Ω, 1/4 W IFR 4702-0471-003 (51190)		
42	D	COAX CABLE WITH SNIFFER LOOP IFR 6050-0534-800 (51190)		
43	D	RESISTOR, 300Ω, 1/4W IFR 4706-3011-001 (51190)		
		<p style="text-align: center;">NOTE</p> <p>TEST EQUIPMENT WITH EQUIVALENT SPECIFICATIONS CAN BE SUBSTITUTED FOR ABOVE LISTED ITEMS.</p>		

SECTION IV  
REMARKS FOR  
AN/GRM-114 MAINTENANCE ALLOCATION CHART

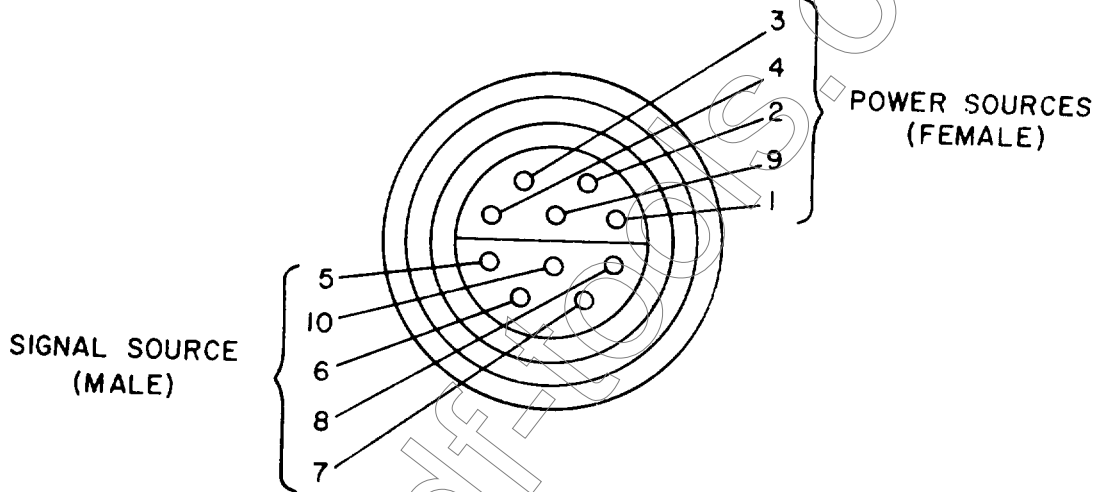
REFERENCE CODE	REMARKS
A	Replacement of upper floor assembly requires calibration of unit.
B	Replacement of VCO Tuner requires alignment.
C	Replacement or repair of module requires VCO Tuner alignment.
D	Replacement of lower floor assembly requires calibration of unit.
E	Replacement or repair of module requires alignment of High Frequency Multiplier Mixer assembly.
F	Replacement or repair of module requires alignment of 1080 MHz Multiplier Amplifier assembly.
G	Replacement or repair of module requires alignment of FM/AM Generator assembly.
H	Replacement or repair of module requires alignment of 250 kHz I.F. Monitor assembly.
I	Replacement or repair of module requires alignment of Regulator and Power Supply assembly.
J	Replacement or repair of module requires alignment of 1200-2200 MHz Oscillator assembly.
K	Replacement or repair of module requires alignment of 108 MHz Bandpass Filter assembly.
L	Replacement or repair of module requires alignment of 100 MHz Amplifier/108 MHz Mixer assembly.
M	Repair by replacement of next higher assembly.

APPENDIX F

PINOUT TABLE FOR EXT ACC CONNECTOR

The table below provides pin assignments for the EXT ACC Connector located on front panel of the AN/GRM-114. This connector provides

power and signal sources for external accessory equipment used with the AN/GRM-114.



EXT ACC CONNECTOR (Front View)

CONNECTOR PIN ASSIGNMENTS			
Pin No.	Power Source	Pin No.	Signal Source
1	+12 V	5	External Modulation
2	+11 V	6	Tone Keying
3	+5 V	7	Microphone Keying
4	-12 v	8	Demodulated Signal Out
9	Ground	10	Signal Ground



<http://www.pdf-tools.com>

RECOMMENDED CHANGES TO EQUIPMENT TECHNICAL PUBLICATIONS



THEN JOT DOWN THE DOPE ABOUT IT ON THIS FORM CAREFULLY TEAR IT OUT, FOLD IT AND DROP IT IN THE MAIL

SOMETHING WRONG WITH THIS PUBLICATION?

FROM (PRINT YOUR UNIT'S COMPLETE ADDRESS)  
 Commander  
 Stateside Army Depot  
 ATTN: AMSTA-US  
 Stateside, N.J. 07705

DATE SENT 10 July 1975

PUBLICATION NUMBER TM 11-5840-340-12	PUBLICATION DATE 23 Jan 74	PUBLICATION TITLE Radar Set AN/PRC-76
---	-------------------------------	--

BE EXACT PIN-POINT WHERE IT IS				IN THIS SPACE TELL WHAT IS WRONG AND WHAT SHOULD BE DONE ABOUT IT.
PAGE NO	PARA GRAPH	FIGURE NO	TABLE NO	
2-25	2-28			<p>Recommend that the installation antenna alignment procedure be changed throughout to specify a 2° IFF antenna lag rather than 1°.</p> <p>REASON: Experience has shown that with only a 1° lag, the antenna servo system is too sensitive to wind gusting in excess of 25 knots, and has a tendency to rapidly accelerate and decelerate as it hunts, causing strain to the drive train. Hunting is minimized by adjusting the lag to 2° without degradation of operation.</p>
3-10	3-3		3-1	<p>Item 5, Function column. Change "2 db" to "5db."</p> <p>REASON: The adjustment procedure the the TRANS POWER FAULT indicator calls for a 3 db (500 watts) adjustment to light the TRANS POWER FAULT indicator.</p>
5-6	5-8			<p>Add new step f.1 to read, "Replace cover plate removed step e.1, above."</p> <p>REASON: To replace the cover plate</p> <p>F03 Zone C 3. On J1-2, change "+24 VDC to "+5 VDC."</p> <p>REASON: This is the output line of the 5 VDC power supply. +24 VDC is the input voltage.</p>

PRINTED NAME GRADE OR TITLE AND TELEPHONE NUMBER SSG I. M. DeSpirito 999-1776	SIGN HERE 
--	---------------

DA FORM 2028-2 JUL 79

PREVIOUS EDITIONS ARE OBSOLETE.

IF YOU HAVE QUESTIONS, WRITE TO THE ADDRESS ON YOUR RECOMMENDATION MAILING LABEL OR CONTACT THE ADDRESS AND GIVE IT TO YOUR HEADQUARTERS.

TEAR ALONG PERFORATED LINE

<http://www.pdf-tools.com>

RECOMMENDED CHANGES TO EQUIPMENT TECHNICAL PUBLICATIONS



THEN...JOT DOWN THE DOPE ABOUT IT ON THIS FORM. CAREFULLY TEAR IT OUT, FOLD IT AND DROP IT IN THE MAIL.

SOMETHING WRONG WITH THIS PUBLICATION?

FROM: (PRINT YOUR UNIT'S COMPLETE ADDRESS)

DATE SENT

PUBLICATION NUMBER

TM 11-6625-3016-14

PUBLICATION DATE

PUBLICATION TITLE

Test Set, Radio AN/GRM-114

BE EXACT PIN-POINT WHERE IT IS

PAGE NO.	PARA-GRAPH	FIGURE NO.	TABLE NO.

IN THIS SPACE TELL WHAT IS WRONG AND WHAT SHOULD BE DONE ABOUT IT:

TEAR ALONG PERFORATED LINE

PRINTED NAME GRADE OR TITLE AND TELEPHONE NUMBER

SIGN HERE

DA FORM 2028-2  
1 JUL 79

PREVIOUS EDITIONS ARE OBSOLETE

P.S.--IF YOUR OUTFIT WANTS TO KNOW ABOUT YOUR RECOMMENDATION MAKE A CARBON COPY OF THIS AND GIVE IT TO YOUR HEADQUARTERS.

TEAR ALONG PERFORATED LINE



POSTAGE AND FEES PAID  
DEPARTMENT OF THE ARMY  
DOD 314

OFFICIAL BUSINESS  
PENALTY FOR PRIVATE USE \$300

DEPARTMENT OF THE ARMY

FOLD BACK

FILL IN YOUR  
UNIT'S ADDRESS

Commander  
US Army Communications-  
Electronics Command  
ATTN: DRSEL-ME-MQ  
Fort Monmouth, New Jersey 07703

http://www.dodtools.com

RECOMMENDED CHANGES TO EQUIPMENT TECHNICAL PUBLICATIONS



THEN...JOT DOWN THE DOPE ABOUT IT ON THIS FORM. CAREFULLY TEAR IT OUT, FOLD IT AND DROP IT IN THE MAIL.

SOMETHING WRONG WITH THIS PUBLICATION?

FROM: (PRINT YOUR UNIT'S COMPLETE ADDRESS)

DATE SENT

PUBLICATION NUMBER

TM 11-6625-3016-14

PUBLICATION DATE

PUBLICATION TITLE

Test Set, Radio AN/GRM-114

BE EXACT PIN-POINT WHERE IT IS

PAGE NO.	PARA-GRAPH	FIGURE NO.	TABLE NO.

IN THIS SPACE TELL WHAT IS WRONG AND WHAT SHOULD BE DONE ABOUT IT:

TEAR ALONG PERFORATED LINE

PRINTED NAME GRADE OR TITLE AND TELEPHONE NUMBER

SIGN HERE

DA FORM 1 JUL 79 2028-2

PREVIOUS EDITIONS ARE OBSOLETE

P.S.--IF YOUR OUTFIT WANTS TO KNOW ABOUT YOUR RECOMMENDATION MAKE A CARBON COPY OF THIS AND GIVE IT TO YOUR HEADQUARTERS.

FILL IN YOUR  
UNIT'S ADDRESS

FOLD BACK

DEPARTMENT OF THE ARMY

OFFICIAL BUSINESS  
PENALTY FOR PRIVATE USE \$300

POSTAGE AND FEES PAID  
DEPARTMENT OF THE ARMY  
DOD 314



TEAR ALONG PERFORATED LINE

Commander  
US Army Communications-  
Electronics Command  
ATTN: DRSEL-ME-MQ  
Fort Monmouth, New Jersey 07703

<http://www.pdf-tools.com>

RECOMMENDED CHANGES TO EQUIPMENT TECHNICAL PUBLICATIONS



**SOMETHING WRONG WITH THIS PUBLICATION?**

THEN...JOT DOWN THE DOPE ABOUT IT ON THIS FORM. CAREFULLY TEAR IT OUT, FOLD IT AND DROP IT IN THE MAIL.

FROM: (PRINT YOUR UNIT'S COMPLETE ADDRESS)

DATE SENT

PUBLICATION NUMBER

TM 11-6625-3016-14

PUBLICATION DATE

PUBLICATION TITLE

Test Set, Radio AN/GRM-114

BE EXACT PIN-POINT WHERE IT IS

PAGE NO.	PARA GRAPH	FIGURE NO.	TABLE NO.

IN THIS SPACE TELL WHAT IS WRONG AND WHAT SHOULD BE DONE ABOUT IT:

TEAR ALONG PERFORATED LINE

PRINTED NAME GRADE OR TITLE AND TELEPHONE NUMBER

SIGN HERE

DA FORM 2028-2  
1 JUL 79

PREVIOUS EDITIONS ARE OBSOLETE

P.S.—IF YOUR UNIT WANTS TO KNOW ABOUT YOUR RECOMMENDATION MAKE A CARBON COPY OF THIS AND GIVE IT TO YOUR HEADQUARTERS.



FILL IN YOUR  
UNIT'S ADDRESS

FOLD BACK

DEPARTMENT OF THE ARMY

POSTAGE AND FEES PAID  
DEPARTMENT OF THE ARMY  
DOD 314



OFFICIAL BUSINESS  
PENALTY FOR PRIVATE USE \$300

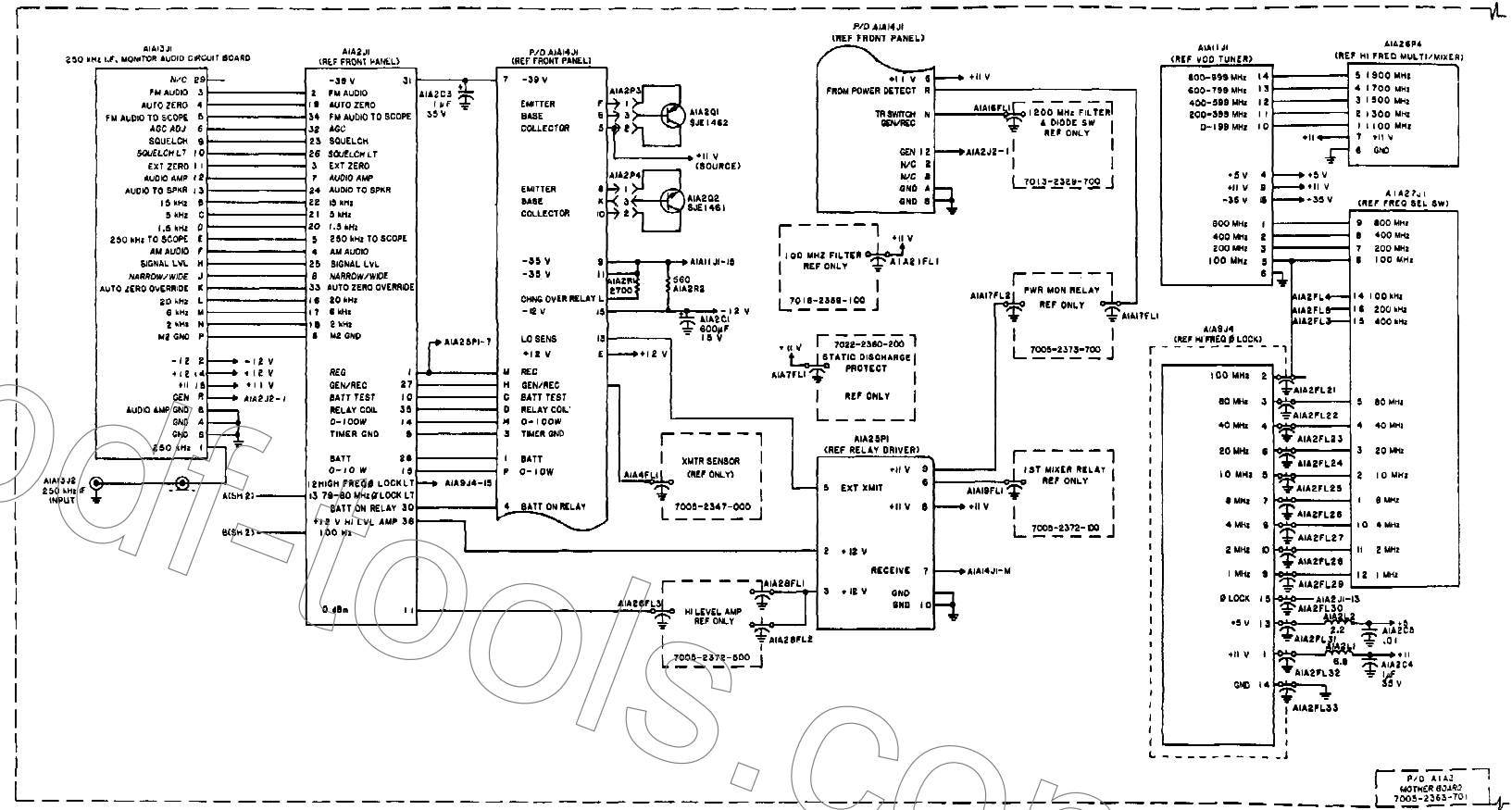
Commander  
US Army Communications-  
Electronics Command  
ATTN: ORSEL-ME-MQ  
Fort Monmouth, New Jersey 07703

TEAR ALONG

ALTERED LINE

<http://www.pdf-tools.com>

http://www.pdffootools.com



- NOTES:
1. LAST REF NO USED: A1A203, A1A204, A1A205, A1A206, A1A207, A1A208, A1A209, A1A210, A1A211, A1A212, A1A213, A1A214, A1A215, A1A216, A1A217, A1A218, A1A219, A1A220, A1A221, A1A222, A1A223, A1A224, A1A225, A1A226, A1A227, A1A228, A1A229, A1A230, A1A231, A1A232, A1A233, A1A234, A1A235, A1A236, A1A237, A1A238, A1A239, A1A240, A1A241, A1A242, A1A243, A1A244, A1A245, A1A246, A1A247, A1A248, A1A249, A1A250, A1A251, A1A252, A1A253, A1A254, A1A255, A1A256, A1A257, A1A258, A1A259, A1A260, A1A261, A1A262, A1A263, A1A264, A1A265, A1A266, A1A267, A1A268, A1A269, A1A270, A1A271, A1A272, A1A273, A1A274, A1A275, A1A276, A1A277, A1A278, A1A279, A1A280, A1A281, A1A282, A1A283, A1A284, A1A285, A1A286, A1A287, A1A288, A1A289, A1A290, A1A291, A1A292, A1A293, A1A294, A1A295, A1A296, A1A297, A1A298, A1A299, A1A300, A1A301, A1A302, A1A303, A1A304, A1A305, A1A306, A1A307, A1A308, A1A309, A1A310, A1A311, A1A312, A1A313, A1A314, A1A315, A1A316, A1A317, A1A318, A1A319, A1A320, A1A321, A1A322, A1A323, A1A324, A1A325, A1A326, A1A327, A1A328, A1A329, A1A330, A1A331, A1A332, A1A333, A1A334, A1A335, A1A336, A1A337, A1A338, A1A339, A1A340, A1A341, A1A342, A1A343, A1A344, A1A345, A1A346, A1A347, A1A348, A1A349, A1A350, A1A351, A1A352, A1A353, A1A354, A1A355, A1A356, A1A357, A1A358, A1A359, A1A360, A1A361, A1A362, A1A363, A1A364, A1A365, A1A366, A1A367, A1A368, A1A369, A1A370, A1A371, A1A372, A1A373, A1A374, A1A375, A1A376, A1A377, A1A378, A1A379, A1A380, A1A381, A1A382, A1A383, A1A384, A1A385, A1A386, A1A387, A1A388, A1A389, A1A390, A1A391, A1A392, A1A393, A1A394, A1A395, A1A396, A1A397, A1A398, A1A399, A1A400, A1A401, A1A402, A1A403, A1A404, A1A405, A1A406, A1A407, A1A408, A1A409, A1A410, A1A411, A1A412, A1A413, A1A414, A1A415, A1A416, A1A417, A1A418, A1A419, A1A420, A1A421, A1A422, A1A423, A1A424, A1A425, A1A426, A1A427, A1A428, A1A429, A1A430, A1A431, A1A432, A1A433, A1A434, A1A435, A1A436, A1A437, A1A438, A1A439, A1A440, A1A441, A1A442, A1A443, A1A444, A1A445, A1A446, A1A447, A1A448, A1A449, A1A450, A1A451, A1A452, A1A453, A1A454, A1A455, A1A456, A1A457, A1A458, A1A459, A1A460, A1A461, A1A462, A1A463, A1A464, A1A465, A1A466, A1A467, A1A468, A1A469, A1A470, A1A471, A1A472, A1A473, A1A474, A1A475, A1A476, A1A477, A1A478, A1A479, A1A480, A1A481, A1A482, A1A483, A1A484, A1A485, A1A486, A1A487, A1A488, A1A489, A1A490, A1A491, A1A492, A1A493, A1A494, A1A495, A1A496, A1A497, A1A498, A1A499, A1A500, A1A501, A1A502, A1A503, A1A504, A1A505, A1A506, A1A507, A1A508, A1A509, A1A510, A1A511, A1A512, A1A513, A1A514, A1A515, A1A516, A1A517, A1A518, A1A519, A1A520, A1A521, A1A522, A1A523, A1A524, A1A525, A1A526, A1A527, A1A528, A1A529, A1A530, A1A531, A1A532, A1A533, A1A534, A1A535, A1A536, A1A537, A1A538, A1A539, A1A540, A1A541, A1A542, A1A543, A1A544, A1A545, A1A546, A1A547, A1A548, A1A549, A1A550, A1A551, A1A552, A1A553, A1A554, A1A555, A1A556, A1A557, A1A558, A1A559, A1A560, A1A561, A1A562, A1A563, A1A564, A1A565, A1A566, A1A567, A1A568, A1A569, A1A570, A1A571, A1A572, A1A573, A1A574, A1A575, A1A576, A1A577, A1A578, A1A579, A1A580, A1A581, A1A582, A1A583, A1A584, A1A585, A1A586, A1A587, A1A588, A1A589, A1A590, A1A591, A1A592, A1A593, A1A594, A1A595, A1A596, A1A597, A1A598, A1A599, A1A600, A1A601, A1A602, A1A603, A1A604, A1A605, A1A606, A1A607, A1A608, A1A609, A1A610, A1A611, A1A612, A1A613, A1A614, A1A615, A1A616, A1A617, A1A618, A1A619, A1A620, A1A621, A1A622, A1A623, A1A624, A1A625, A1A626, A1A627, A1A628, A1A629, A1A630, A1A631, A1A632, A1A633, A1A634, A1A635, A1A636, A1A637, A1A638, A1A639, A1A640, A1A641, A1A642, A1A643, A1A644, A1A645, A1A646, A1A647, A1A648, A1A649, A1A650, A1A651, A1A652, A1A653, A1A654, A1A655, A1A656, A1A657, A1A658, A1A659, A1A660, A1A661, A1A662, A1A663, A1A664, A1A665, A1A666, A1A667, A1A668, A1A669, A1A670, A1A671, A1A672, A1A673, A1A674, A1A675, A1A676, A1A677, A1A678, A1A679, A1A680, A1A681, A1A682, A1A683, A1A684, A1A685, A1A686, A1A687, A1A688, A1A689, A1A690, A1A691, A1A692, A1A693, A1A694, A1A695, A1A696, A1A697, A1A698, A1A699, A1A700, A1A701, A1A702, A1A703, A1A704, A1A705, A1A706, A1A707, A1A708, A1A709, A1A710, A1A711, A1A712, A1A713, A1A714, A1A715, A1A716, A1A717, A1A718, A1A719, A1A720, A1A721, A1A722, A1A723, A1A724, A1A725, A1A726, A1A727, A1A728, A1A729, A1A730, A1A731, A1A732, A1A733, A1A734, A1A735, A1A736, A1A737, A1A738, A1A739, A1A740, A1A741, A1A742, A1A743, A1A744, A1A745, A1A746, A1A747, A1A748, A1A749, A1A750, A1A751, A1A752, A1A753, A1A754, A1A755, A1A756, A1A757, A1A758, A1A759, A1A760, A1A761, A1A762, A1A763, A1A764, A1A765, A1A766, A1A767, A1A768, A1A769, A1A770, A1A771, A1A772, A1A773, A1A774, A1A775, A1A776, A1A777, A1A778, A1A779, A1A780, A1A781, A1A782, A1A783, A1A784, A1A785, A1A786, A1A787, A1A788, A1A789, A1A790, A1A791, A1A792, A1A793, A1A794, A1A795, A1A796, A1A797, A1A798, A1A799, A1A800, A1A801, A1A802, A1A803, A1A804, A1A805, A1A806, A1A807, A1A808, A1A809, A1A810, A1A811, A1A812, A1A813, A1A814, A1A815, A1A816, A1A817, A1A818, A1A819, A1A820, A1A821, A1A822, A1A823, A1A824, A1A825, A1A826, A1A827, A1A828, A1A829, A1A830, A1A831, A1A832, A1A833, A1A834, A1A835, A1A836, A1A837, A1A838, A1A839, A1A840, A1A841, A1A842, A1A843, A1A844, A1A845, A1A846, A1A847, A1A848, A1A849, A1A850, A1A851, A1A852, A1A853, A1A854, A1A855, A1A856, A1A857, A1A858, A1A859, A1A860, A1A861, A1A862, A1A863, A1A864, A1A865, A1A866, A1A867, A1A868, A1A869, A1A870, A1A871, A1A872, A1A873, A1A874, A1A875, A1A876, A1A877, A1A878, A1A879, A1A880, A1A881, A1A882, A1A883, A1A884, A1A885, A1A886, A1A887, A1A888, A1A889, A1A890, A1A891, A1A892, A1A893, A1A894, A1A895, A1A896, A1A897, A1A898, A1A899, A1A900, A1A901, A1A902, A1A903, A1A904, A1A905, A1A906, A1A907, A1A908, A1A909, A1A910, A1A911, A1A912, A1A913, A1A914, A1A915, A1A916, A1A917, A1A918, A1A919, A1A920, A1A921, A1A922, A1A923, A1A924, A1A925, A1A926, A1A927, A1A928, A1A929, A1A930, A1A931, A1A932, A1A933, A1A934, A1A935, A1A936, A1A937, A1A938, A1A939, A1A940, A1A941, A1A942, A1A943, A1A944, A1A945, A1A946, A1A947, A1A948, A1A949, A1A950, A1A951, A1A952, A1A953, A1A954, A1A955, A1A956, A1A957, A1A958, A1A959, A1A960, A1A961, A1A962, A1A963, A1A964, A1A965, A1A966, A1A967, A1A968, A1A969, A1A970, A1A971, A1A972, A1A973, A1A974, A1A975, A1A976, A1A977, A1A978, A1A979, A1A980, A1A981, A1A982, A1A983, A1A984, A1A985, A1A986, A1A987, A1A988, A1A989, A1A990, A1A991, A1A992, A1A993, A1A994, A1A995, A1A996, A1A997, A1A998, A1A999, A1A1000.
  2. ALL POLARIZED CAPACITORS ARE TANTALUM.
  3. ALL REF NOS CARRY AN ASSIGNED DESIGNATOR SERIES (i.e. THIS SCHEMATIC CARRIES SERIES A1A2 THEREFORE P1 IS DESIGNATED A1A2P1).

A1A2 MOTHER BOARD 7005-2363-701

P/D A1A2 MOTHER BOARD 7005-2363-701

Figure 6-1. AN/GRM-114 mother board A1A2, schematic diagram (sheet 1 of 2).

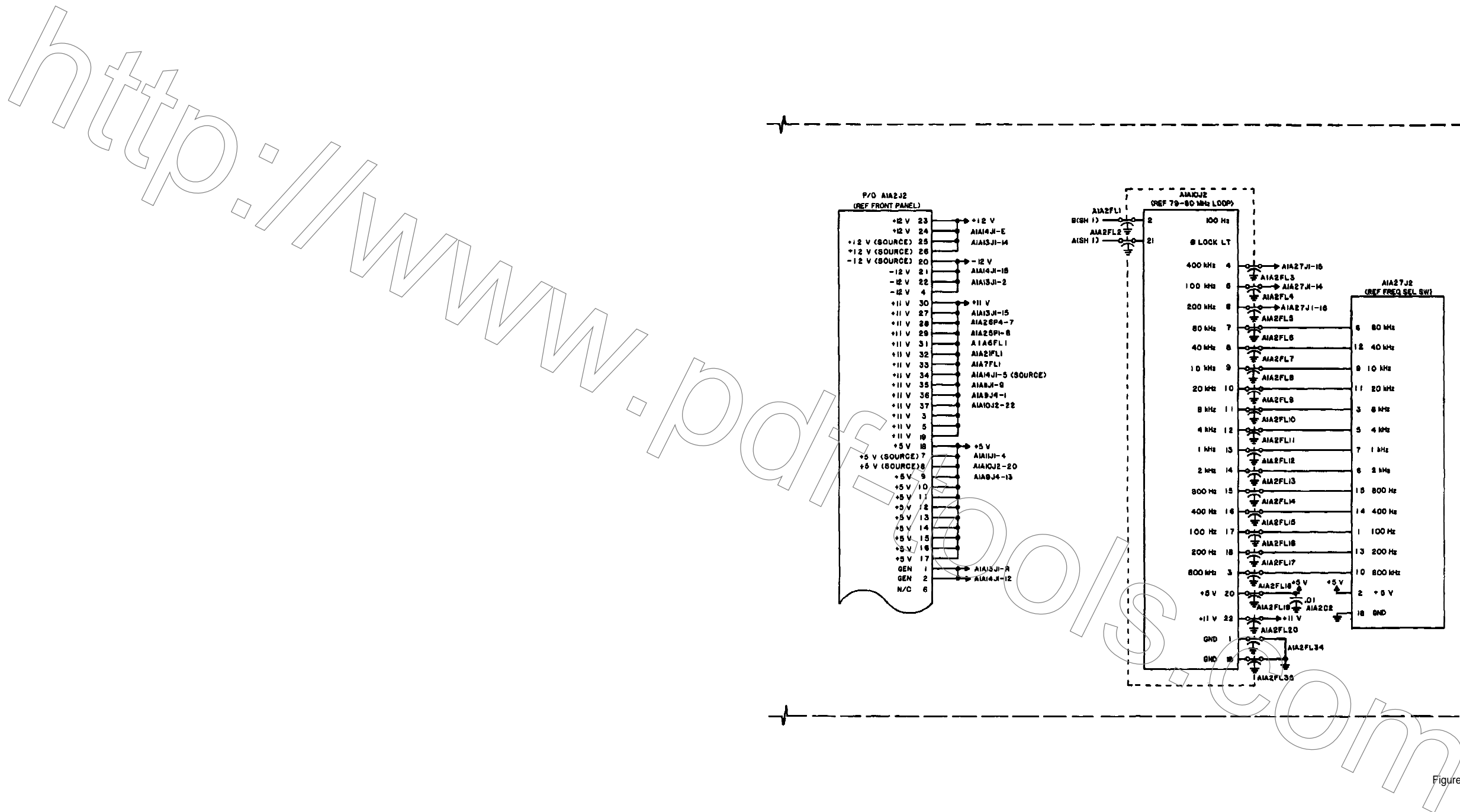


Figure 6-1. AN/GRM-114 motherboard A1A2, schematic diagram (sheet 2 of 2).

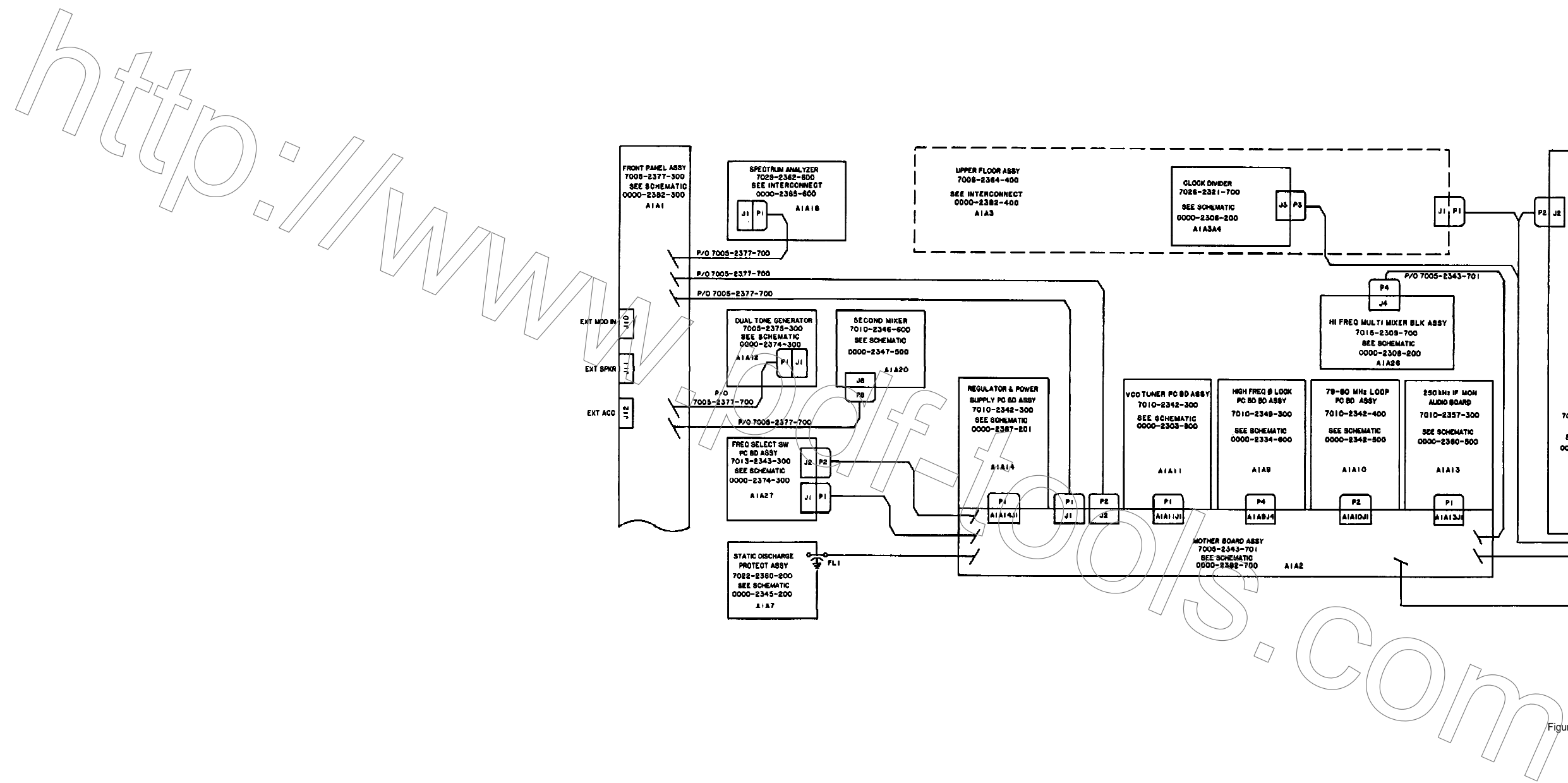


Figure 6-2. AN/GRM-114 interconnect A1 schmetic diagram (sheet 1 of 2).

http://www.1000parts.com

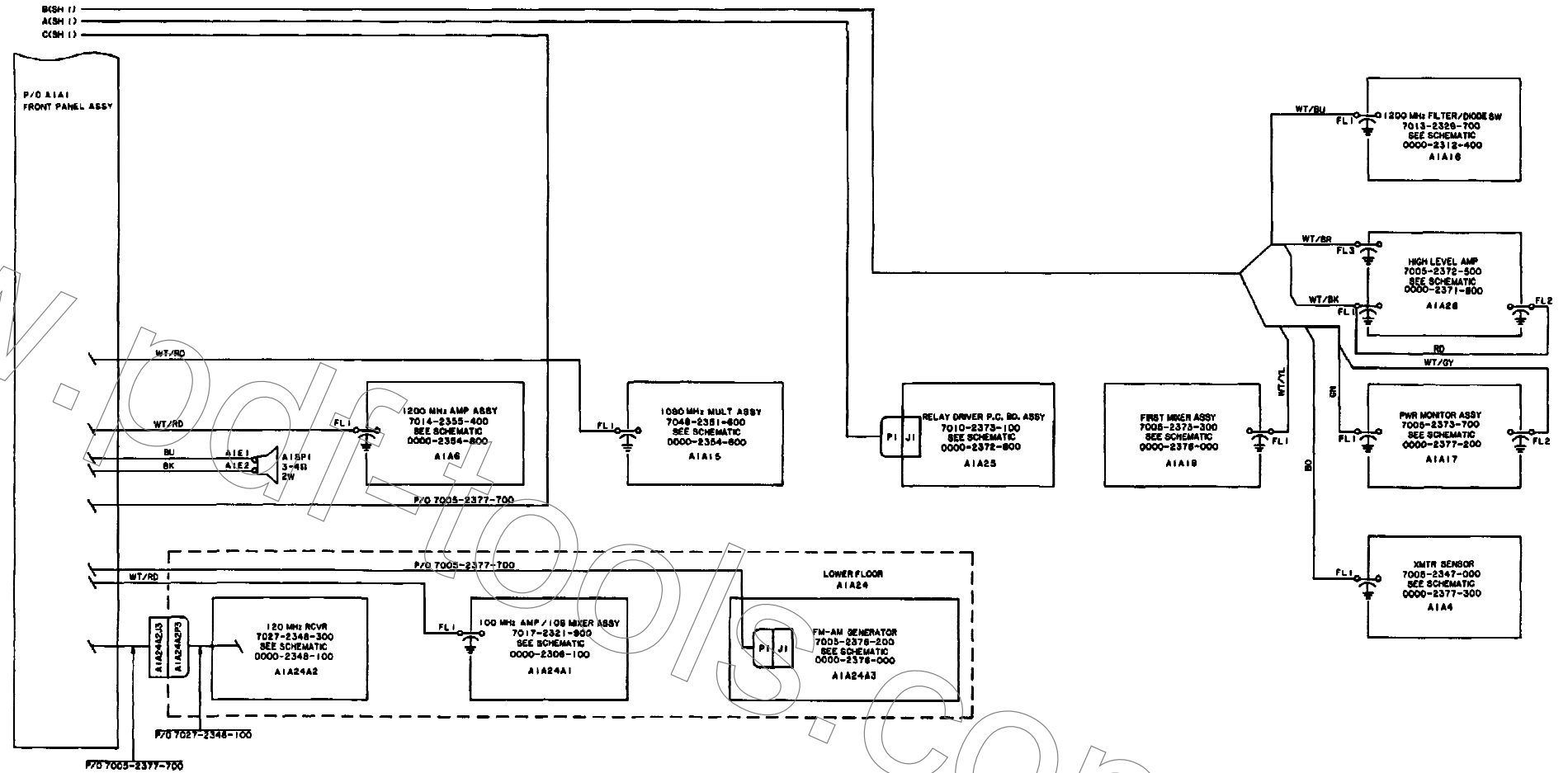


Figure 6-2. AN/GRM-114 interconnect A1, schematic diagram (sheet 2 of 2).

A1A1  
FRONT PANEL ASSY  
7005-2377-700

- LAST REF NO USED:  
A1A2 A1A3 A1A4 A1A5 A1A6 A1A7 A1A8 A1A9 A1A10 A1A11 A1A12 A1A13 A1A14 A1A15 A1A16 A1A17 A1A18 A1A19 A1A20 A1A21 A1A22 A1A23 A1A24 A1A25 A1A26 A1A27 A1A28 A1A29 A1A30 A1A31 A1A32 A1A33 A1A34 A1A35 A1A36 A1A37 A1A38 A1A39 A1A40 A1A41 A1A42 A1A43 A1A44 A1A45 A1A46 A1A47 A1A48 A1A49 A1A50 A1A51 A1A52 A1A53 A1A54 A1A55 A1A56 A1A57 A1A58 A1A59 A1A60 A1A61 A1A62 A1A63 A1A64 A1A65 A1A66 A1A67 A1A68 A1A69 A1A70 A1A71 A1A72 A1A73 A1A74 A1A75 A1A76 A1A77 A1A78 A1A79 A1A80 A1A81 A1A82 A1A83 A1A84 A1A85 A1A86 A1A87 A1A88 A1A89 A1A90 A1A91 A1A92 A1A93 A1A94 A1A95 A1A96 A1A97 A1A98 A1A99 A1A100
  - ALL RESISTORS ARE 1/8W, 10% UNLESS OTHERWISE NOTED.
  - ALL RESISTANCE IS EXPRESSED IN OHMS UNLESS OTHERWISE NOTED.
  - CONTACT ARRANGEMENT FOR A1A1 SW6 BANDWIDTH
- A1A1SW4 IS GANGED TO A1A1R4 AND IS NORMALLY CLOSED. CONTACTS OPEN WHEN A1A1R4 IS FULLY CCW.
  - CONTACT ARRANGEMENT FOR A1A1 SW5, PWR-OFF-BATT.
- CONTACT ARRANGEMENT FOR A1A1 SW13, HI-NORM.
- CONTACT ARRANGEMENT FOR A1A1 SW15, AUTO-OFF-BATT.
- A1A1SW14 IS GANGED TO A1A1R7 AND IS NORMALLY CLOSED. CONTACTS OPEN WHEN A1A1R7 IS FULLY CCW.
  - A1A1SW12 IS GANGED TO A1A1R6 AND IS NORMALLY CLOSED. CONTACTS OPEN WHEN A1A1R6 IS FULLY CCW.
  - ALL REF NOS CARRY AN ASSIGNED DESIGNATOR SERIES (E.G. THIS SCHEMATIC CARRIES SERIES A1A1 THEREFORE RESISTOR R1 IS A1A1R1).

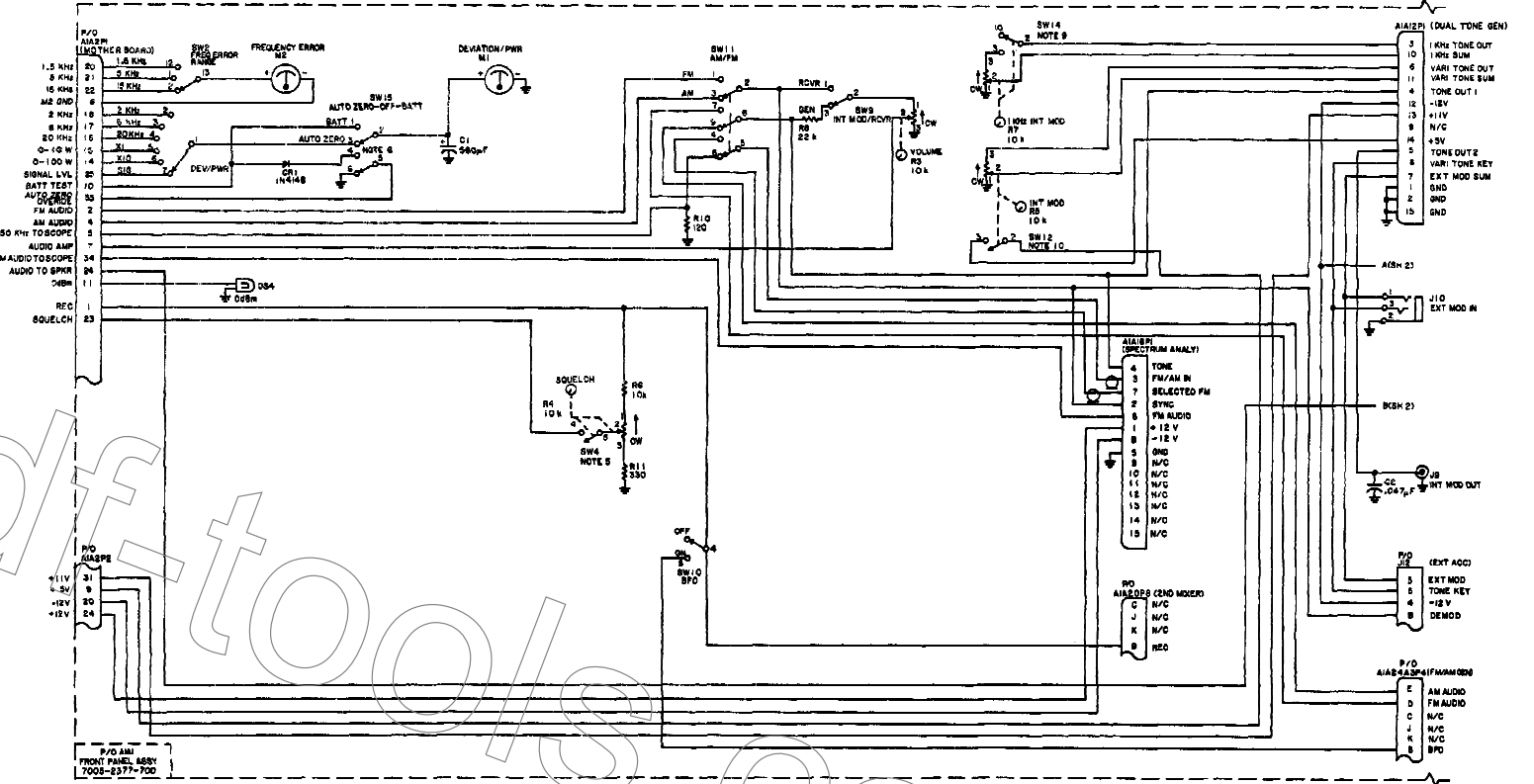


Figure 6-3. AN/GRM-114 front panel assembly AT1A1, schematic diagram (sheet 1 of 2).

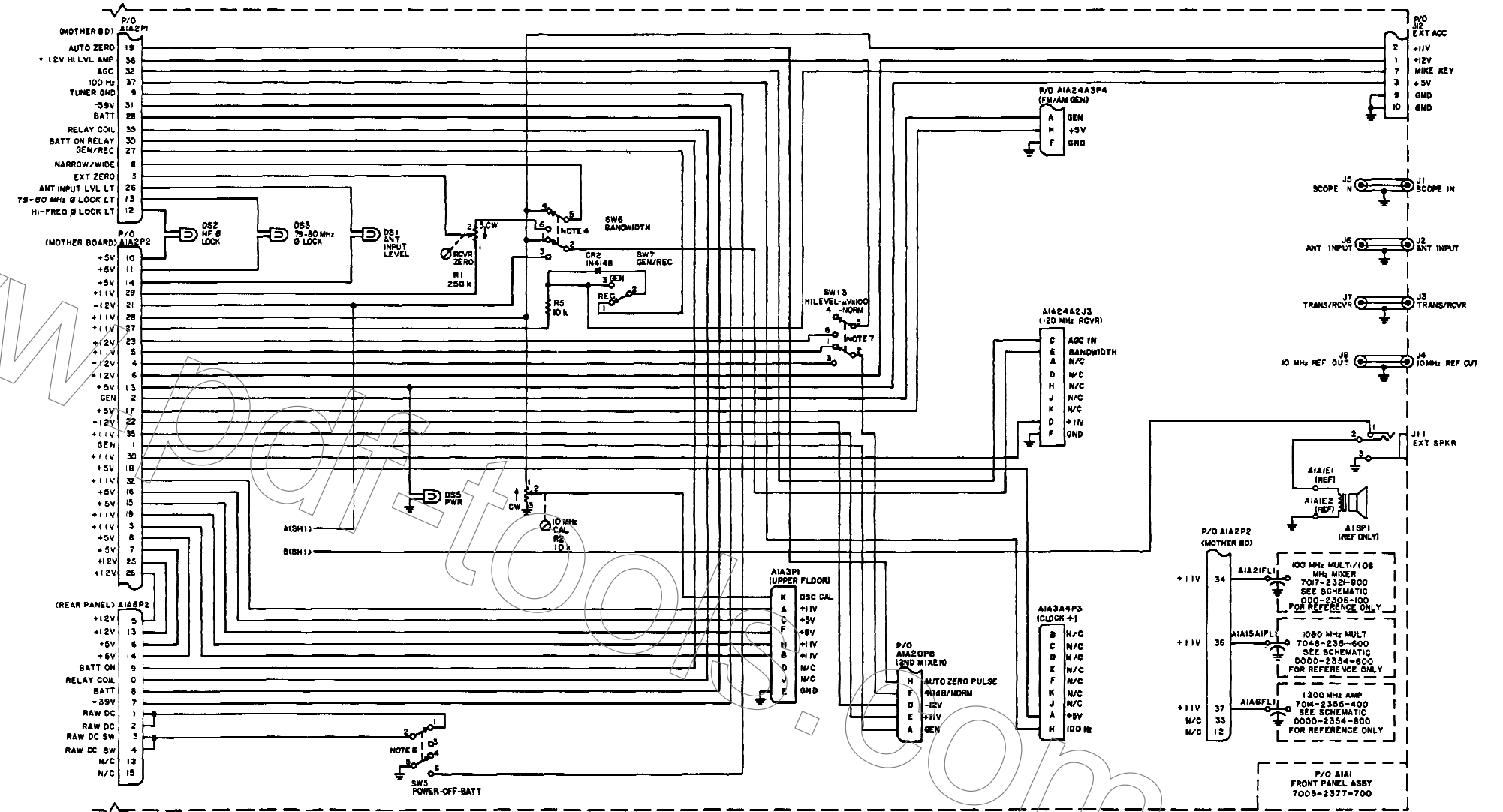
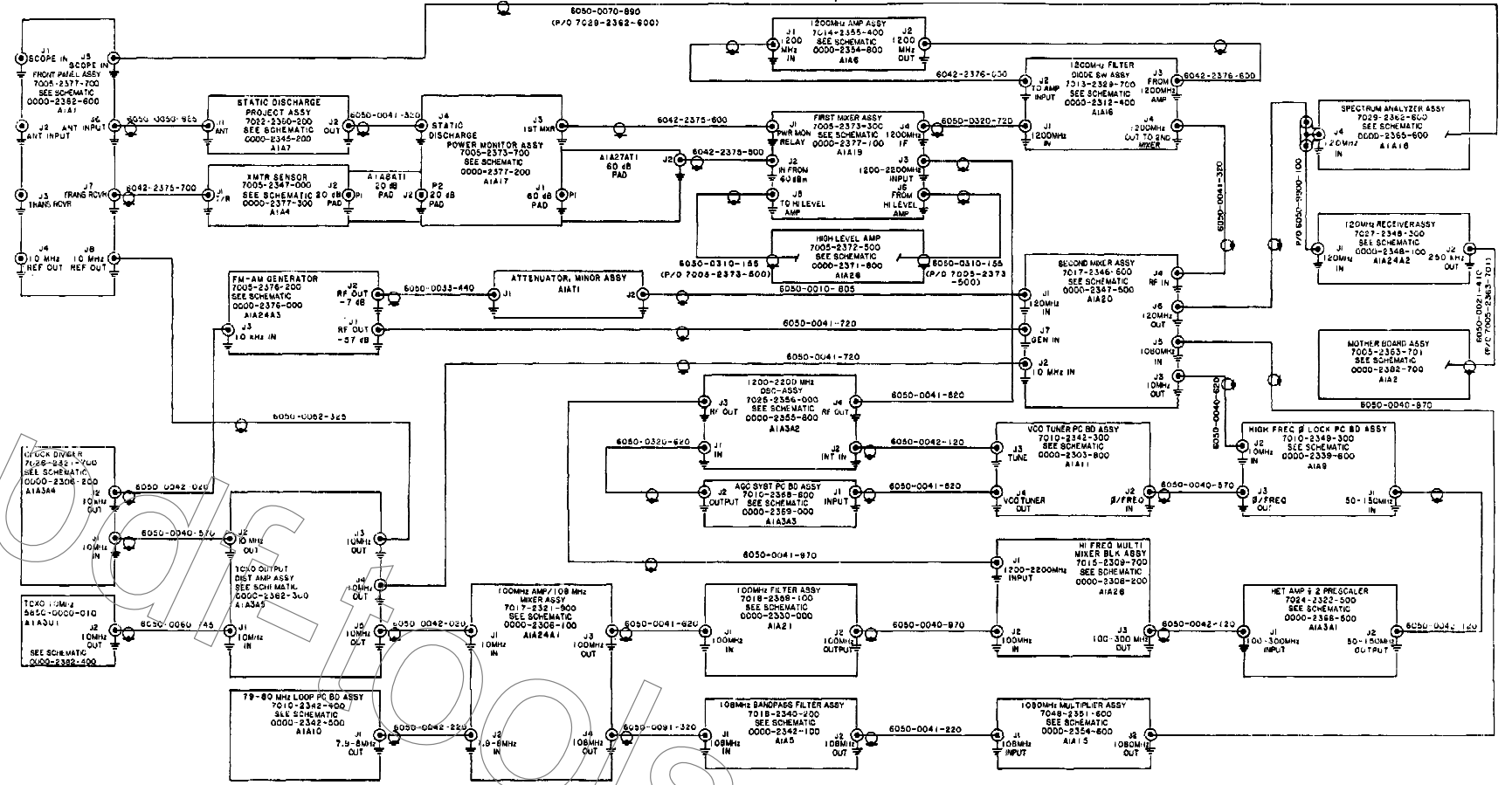


Figure 6-3. AN/GRM-114 front panel assembly A1A1, schematic diagram (sheet 2 of 2).

http://www...



NOTES:

1. FOR PURPOSE OF CLARITY, INTERCONNECTING CABLE ENDS ARE NOT LABELED WITH A REFERENCE DESIGNATOR. EACH CABLE END HOWEVER CARRIES THE DESIGNATOR SERIES AND NUMBER OF ITS MATING JACK.

EXAMPLES:

A.) CABLE END CONNECTING TO A1A24A3J3 CARRIES DESIGNATOR A1A24A3J3

B.) CABLE END CONNECTING TO A1A11-J1 CARRIES DESIGNATOR A1A11-J1

BOTH JACKS AND PLUG DESIGNATORS ARE PROVIDED FOR COMPONENTS / ASSEMBLIES WHICH CONNECT TO USE OF INTERCONNECTING CABLES.

THESE CONNECTIONS ARE:

A1A2J2 MATES TO A1A24A1P1

A1A1P1 MATES TO A1A27A1-J1

A1A2A1-J2 MATES TO A1A17P2

Figure 6-4. AN/GRM-114 coaxial cable assembly A1A22, schematic diagram.



<http://www.pdf.com>

NOTES:  
 1. ALL REF NOS CARRY AN ASSIGNED DESIGNATOR SERIES 144. THIS SCHEMATIC CARRIES SERIES A1A3. A1A3A1, A1A3A2, A1A3A3, A1A3A4, A1A3A5, A1A3A11. THEREFORE, J3 ON ASSY A1A3A5 IS DESIGNATED A1A3A5J3.

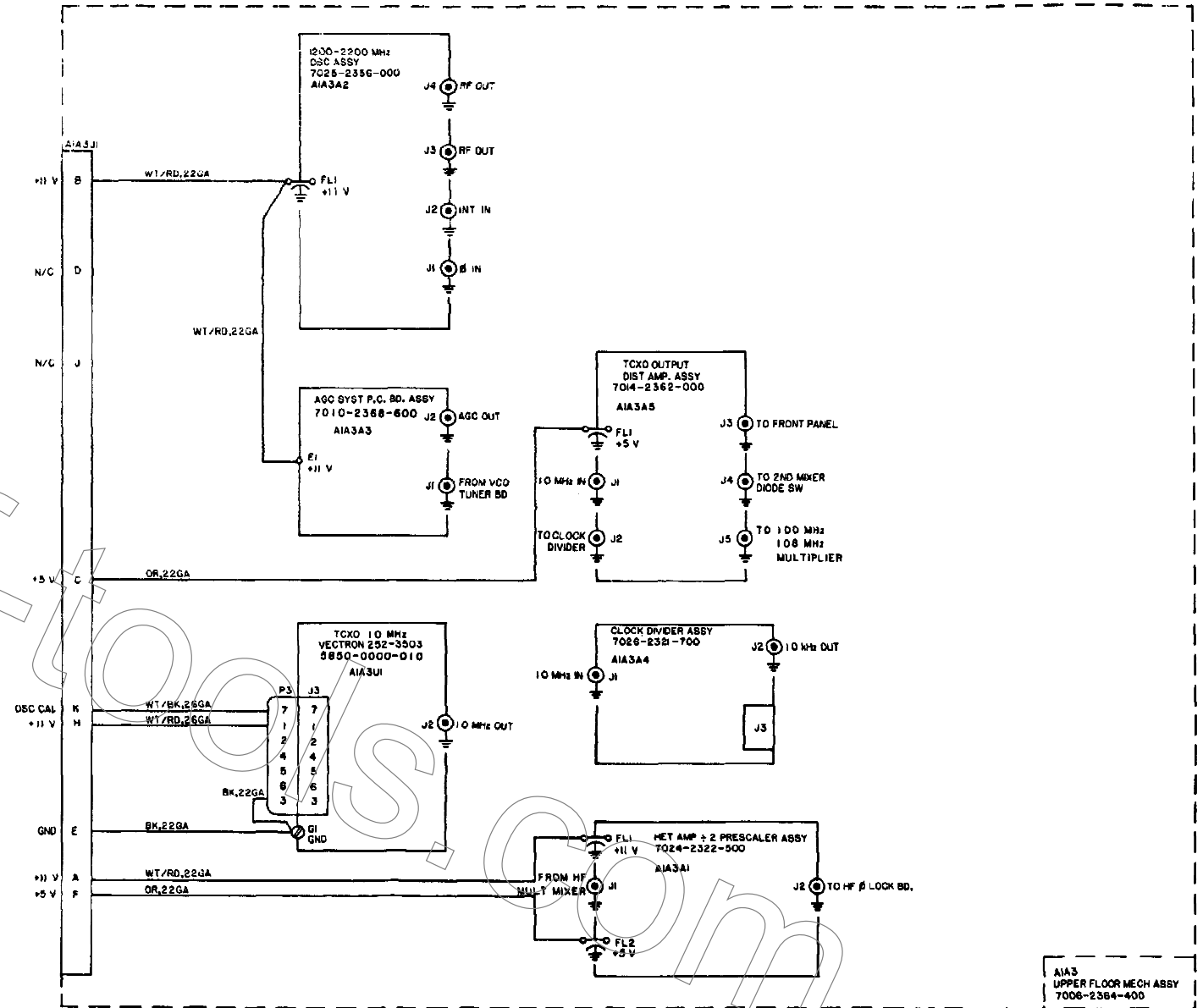


Figure 6-5. AN/GRM-114 upper floor assembly A1A3, schematic diagram.

http://www.proftools.com

- DRAFTSMAN NOTES:**
- ON SMT 1 J801 BECOMES A1A3A1I  
 J802 A1A3A1I2  
 FL601 A1A3A1FL1  
 FL602 A1A3A1FL2  
 J2401 A1A9J1
- NOTES:**
1. LAST REF NO USED:  
 A1A3A1FL2  
 A1A3A1I2  
 A1A3A1I014  
 A1A3A1A1C1M  
 A1A3A1A1E2  
 A1A3A1A1L5  
 A1A3A1A1Q4  
 A1A3A1A1R7  
 A1A3A1A1K2
  2. ALL RESISTORS ARE 1/8 W, 10% UNLESS OTHERWISE NOTED.
  3. ALL RESISTANCE IS EXPRESSED IN OHMS UNLESS OTHERWISE NOTED.
  4. ALL CAPACITANCE IS EXPRESSED IN PICO FARADS UNLESS OTHERWISE NOTED.
  5. ALL REF NOS CARRY AN ASSIGNED DESIGNATOR SERIES (i.e., THIS SCHEMATIC CARRIES SERIES A1A3A1, A1A3A1I; THEREFORE, R1 IS DESIGNATED A1A3A1A1R1).

A1A3A1  
 HET AMP + 2 PRESCALER  
 ASSY  
 7024-2322-500

A1A3A1I  
 HET AMP + 2 PRESCALER  
 P.C. BD. ASSY  
 7010-2368-400

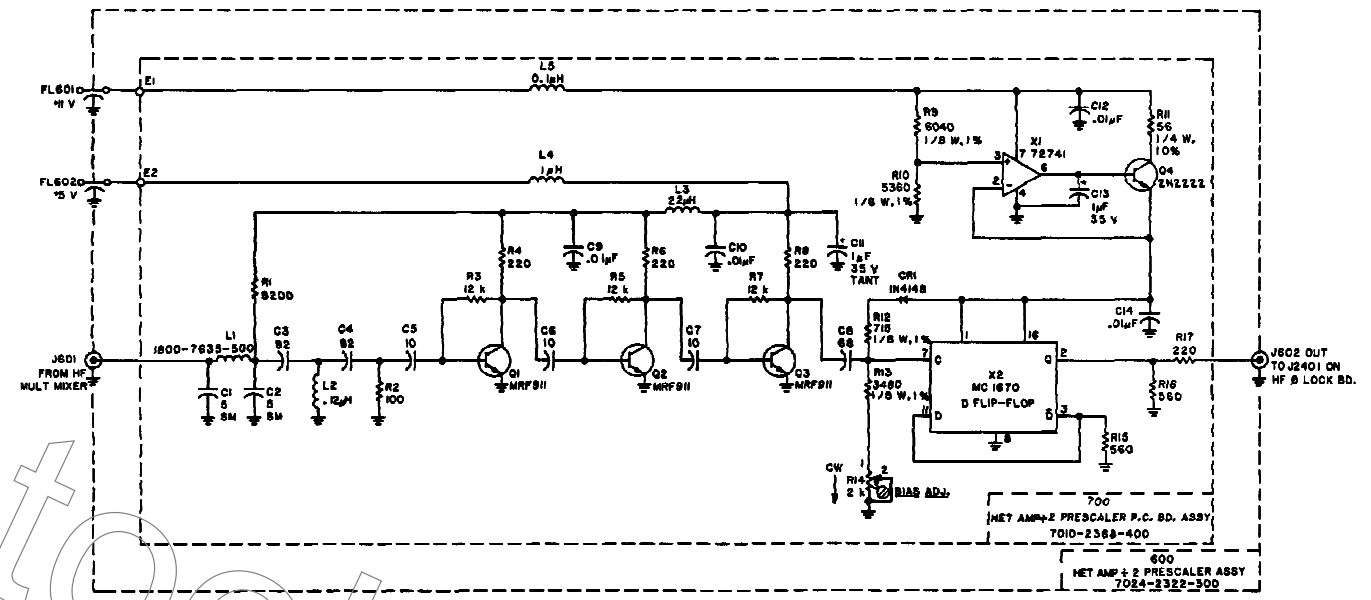


Figure 6-6. Heterodyne amplifier + 2 prescaler A1A3A1, schematic diagram.

http://www.aircrafts.com

- NOTES:
1. LAST REF NO USED:  
 A1A3A2C2  
 A1A3A2F1  
 A1A3A2J4  
 A1A3A2R9  
 A1A3A2E2  
 A1A3A2ACB2  
 A1A3A2A1CR2  
 A1A3A2AB  
 A1A3A2A1L8  
 A1A3A2A1Q5  
 A1A3A2A1R22
  2. ALL RESISTORS ARE 1/8 W, 10% UNLESS OTHERWISE NOTED.
  3. ALL RESISTANCE IS EXPRESSED IN OHMS UNLESS OTHERWISE NOTED.
  4. ALL CAPACITANCE IS EXPRESSED IN PICO FARADS UNLESS OTHERWISE NOTED.
  5. L2, L3, L4, L5, L6 ARE 1800-2359-700.
  6. L7 IS FORMED BY THE STRAY INDUCTANCE OF A 0.1" LENGTH OF 22 AWG BUS WIRE.
  7. ALL REF NOS CARRY AN ASSIGNED DESIGNATOR SERIES (A4 THIS DWG. CARRIES SERIES A1A3A2 & A1A3A2A1); THEREFORE W IS DESIGNATED A1A3A2A1R12.

DRAFTSMAN NOTES:

ON SHT 1, J801 BECOMES A1A3A2J  
 J802 A1A3A2K  
 J803 A1A3A2L  
 J804 A1A3A2M  
 FL801 A1A3A2FL1

A1A3A2  
 MECH ASSY.  
 1800-2200 MHz OSC  
 7025-2356-000

A1A3A2A1  
 PCB ASSY.  
 1800-2200 MHz OSC  
 7010-2355-900

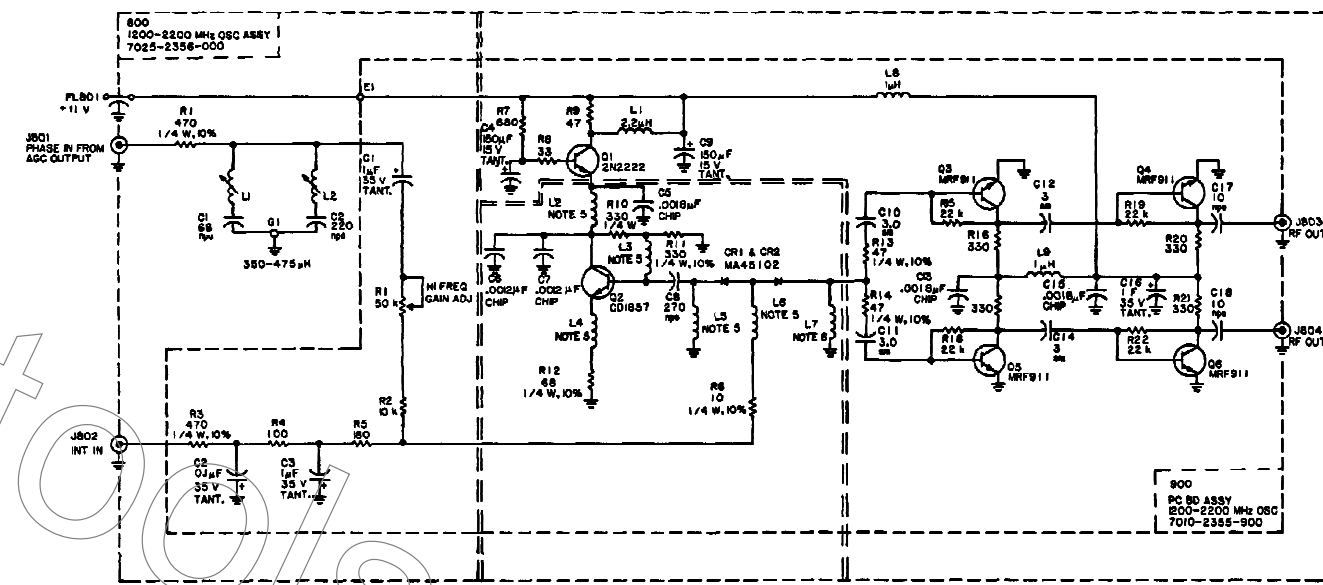


Figure 6-7. 1200-2200 MHz oscillator A1A3A2, schematic diagram.

http://www.pdf-tools.com

- NOTES:
1. LAST REF NO USED:  
A1A3A3D  
A1A3A3R2  
A1A3A3E1  
A1A3A3J2  
A1A3A3D5  
A1A3A3R30  
A1A3A3X8
  2. ALL RESISTORS ARE 1/4 W, 10% UNLESS OTHERWISE NOTED.
  3. ALL RESISTANCE IS EXPRESSED IN OHMS UNLESS OTHERWISE NOTED.
  4. ALL REF NOS CARRY AN ASSIGNED DESIGNATOR SERIES (e.g., THIS SCHEMATIC CARRIES SERIES A1A3A3; THEREFORE, R<sub>1</sub> IS DESIGNATED A1A3A3R<sub>1</sub>).

DRAFTSMAN NOTE:  
ON SHY J1001 BECOMES A1A3A3J1  
J1002 A1A3A3J2  
E1001 A1A3A3E1

A1A3A3  
AGC SYST  
PC. 60. 485Y  
7010-2368-600

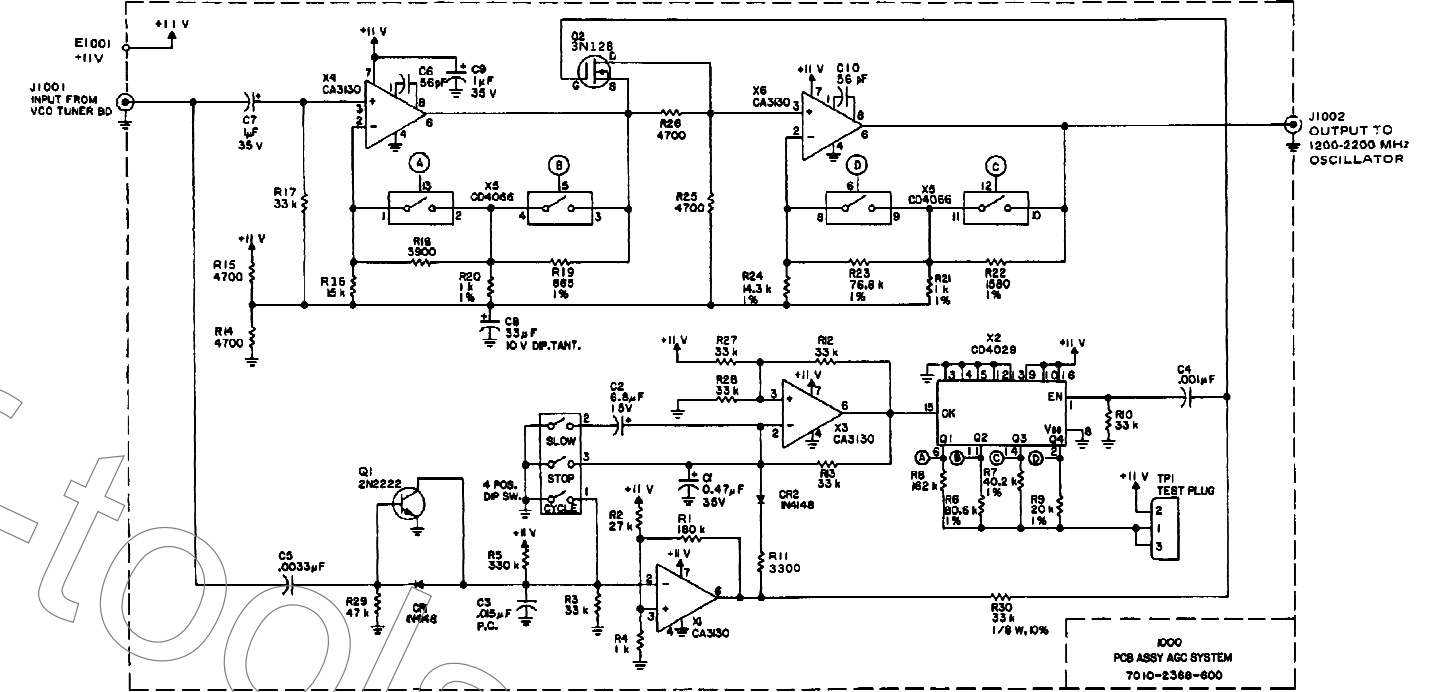


Figure 6-8. AGC system A1A3A3, schematic diagram.

http://www.pdf-tools.com

1. LAST REF. NO. USED:  
 A1A3A4C1  
 A1A3A4FL1  
 A1A3A4J3  
 A1A3A41G2  
 A1A3A41E4  
 A1A3A41Q1  
 A1A3A41J7  
 A1A3A41XB
2. ALL RESISTORS ARE 1/4W, 10% UNLESS OTHERWISE NOTED.
3. ALL RESISTANCE IS EXPRESSED IN OHMS UNLESS OTHERWISE NOTED.
4. ALL REF. NOS. CARRY AN ASSIGNED DESIGNATOR SERIES (4-). THIS SCHEMATIC CARRIES SERIES A1A3A4 AND A1A3A4A1. THEREFORE R1 IS DESIGNATED A1A3A4A1R1.

DRAFTSMAN'S NOTES:  
 J1101 ON SHT 1 BECOMES A1A3A4J1  
 J1102                   A1A3A4J2  
 J1103                   A1A3A4J3  
 FL1101                 A1A3A4FL1

A1A3A4A1  
 CLOCK DIVIDER  
 P.C. Bd. ASSY.  
 7010-8309-300

A1A3A4  
 MECH ASSY  
 CLOCK DIVIDER  
 7026-8321-700

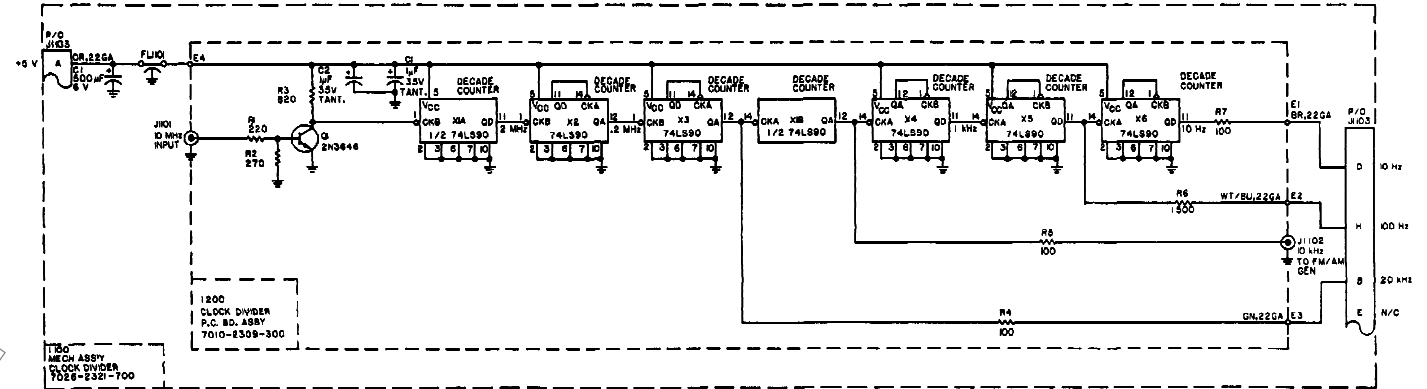


Figure 6-9. Clock divider A1A3A4, schematic diagram.

<http://www.pcb-at-tools.com>

A1A3A5  
TCXO OUTPUT DIST ASSY  
7014-2362-000

A1A3A5A1  
TCXO OUTPUT DIST  
AMP P.C. BD. ASSY  
7000-2361-900

- DRAFTSMAN NOTES:  
ON SHY 1: J301 BECOMES A1A3A5.1  
J302 A1A3A5.2  
J303 A1A3A5.3  
J304 A1A3A5.4  
J306 A1A3A5.6  
FLJ301 A1A3A5FL1
- NOTES:  
1. LAST REF NO USED:  
A1A3A5FL1  
A1A3A5J5  
A1A3A5A1C4  
E1  
L1  
Q5  
R15
2. ALL RESISTORS ARE 1/8 W, 10% UNLESS OTHERWISE NOTED.  
3. ALL RESISTANCE IS EXPRESSED IN OHMS UNLESS OTHERWISE NOTED.  
4. ALL REF NOS CARRY AN ASSIGNED DESIGNATOR SERIES (e.g. THIS SCHEMATIC CARRIES SERIES A1A3A5 & A1A3A5A1. THEREFORE, R1 IS DESIGNATED A1A3A5A1R1).

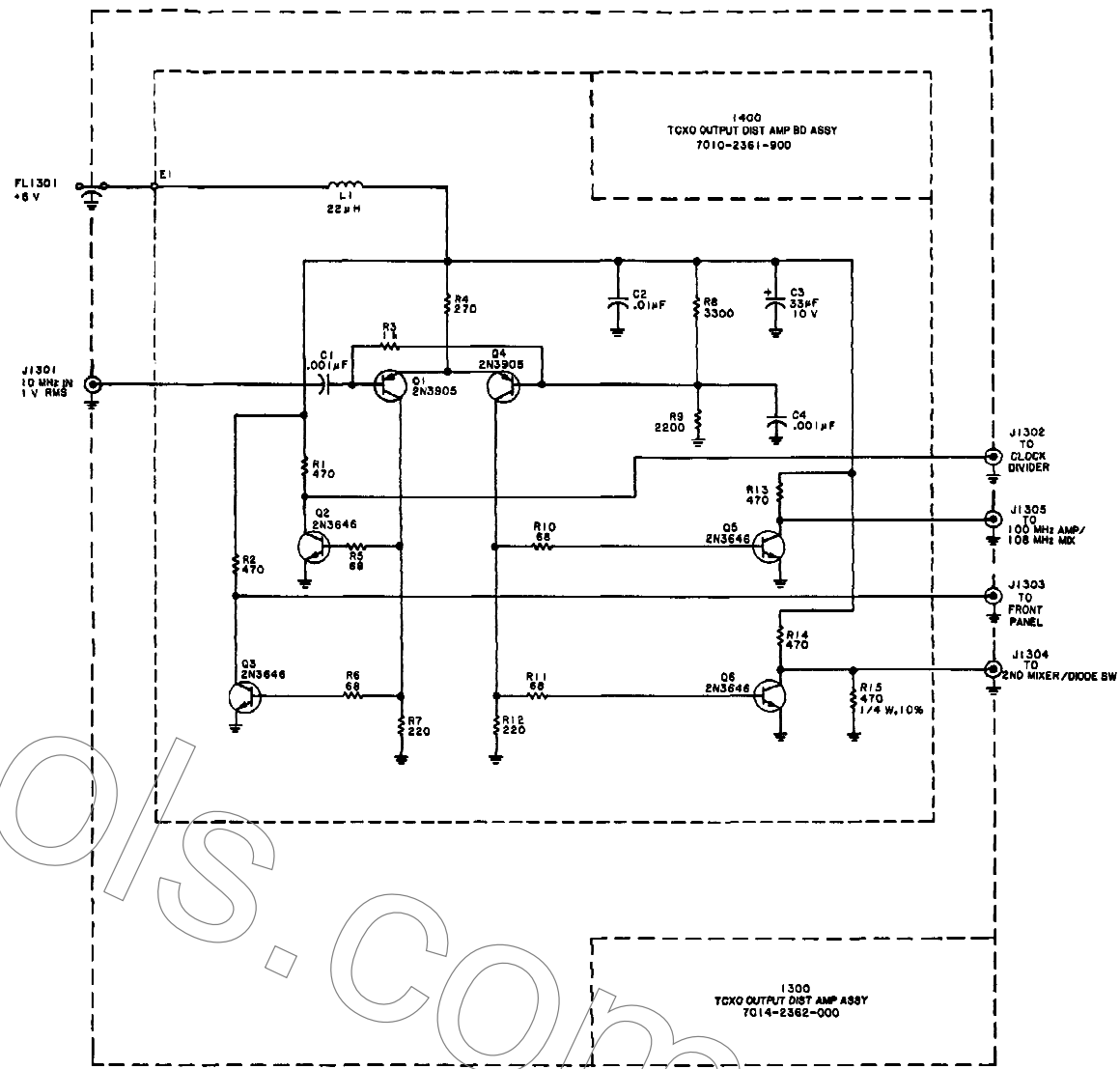


Figure 6-10. TCXO output distribution amplifier A1A3A5, schematic diagram.

http://www.pdf-tools.com

DRAFTSMAN NOTES:

J1501 BECOMES A1A4J1  
J1502 A1A4J2  
FL1501 A1A4FL1

NOTES:

1. LAST REF NO. USED:

A1A4CR1  
FL1  
G1  
J2  
R2

2. ALL REF NO'S CARRY AN ASSIGNED DESIGNATOR SERIES (e.g. THIS SCHEMATIC CARRIES SERIES A1A4 THEREFORE R1 IS DESIGNATED A1A4R1).

A1A4  
MECH ASSY, XMTR SENSOR  
7005-2374-000

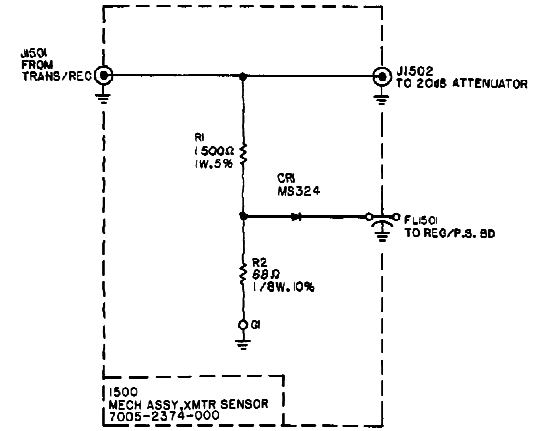


Figure 6-11. Transmitter sensor A1A4, schematic diagram.

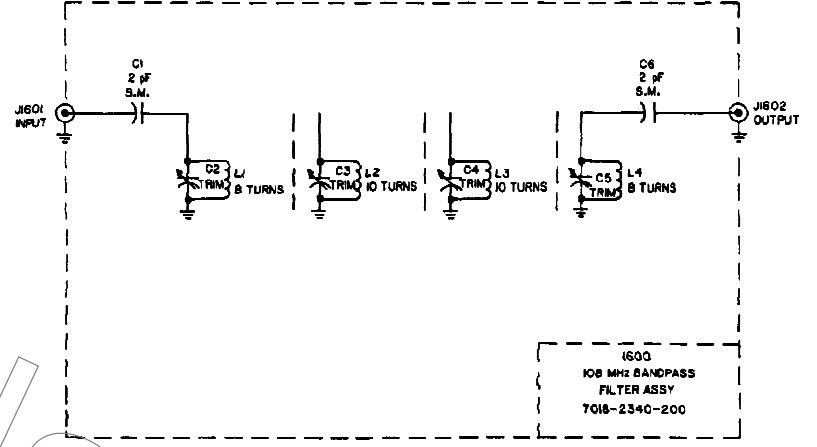
http://www.poftools.com

DRAFTSMAN NOTES:  
ON SHT 1 J1601 BECOMES A1A5J1  
J1602 A1A5J2

NOTES:  
1. LAST REF NO USED:  
A1A5C6  
J2  
L4

2. ALL REF NO'S CARRY AN ASSIGNED DESIGNATOR  
SERIES (1-). THIS SCHEMATIC CARRIES SERIES A1A5;  
THEREFORE, C1 IS DESIGNATED A1A5C1).

A1A5  
108 MHz BANDPASS FILTER ASSY  
7018-2340-200

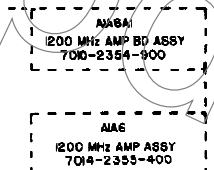


1600  
108 MHz BANDPASS  
FILTER ASSY  
7018-2340-200

Figure 6-12. 108 MHz bandpass filter A1A5, schematic diagram.



http://www.pdffools.com



NOTES:

1. LAST REF NO USED:  
A1A6FL1  
J2  
C1  
A1A6A1CB  
E1  
G1  
Q3  
R10
2. ALL RESISTORS ARE 1/4, 10% UNLESS OTHERWISE NOTED.
3. ALL RESISTANCE IS EXPRESSED IN OHMS UNLESS OTHERWISE NOTED.
4. ALL CAPACITANCE IS EXPRESSED IN PICOPARADS UNLESS OTHERWISE NOTED.
5. THE VALUE OF R10 IS SET AT TEST TO REDUCE GAIN (FOR TESTING PURPOSES ONLY).
6. ALL REF NOS CARRY AN ASSIGNED DESIGNATOR SERIES (e.g., THIS SCHEMATIC CARRIES SERIES A1A6 & A1A6A1; THEREFORE, R1 IS DESIGNATED A1A6A1R1).

DRAFTSMAN NOTES:

- J701 = A1A6J1
- J702 = A1A6J2
- FL1701 = A1A6FL1

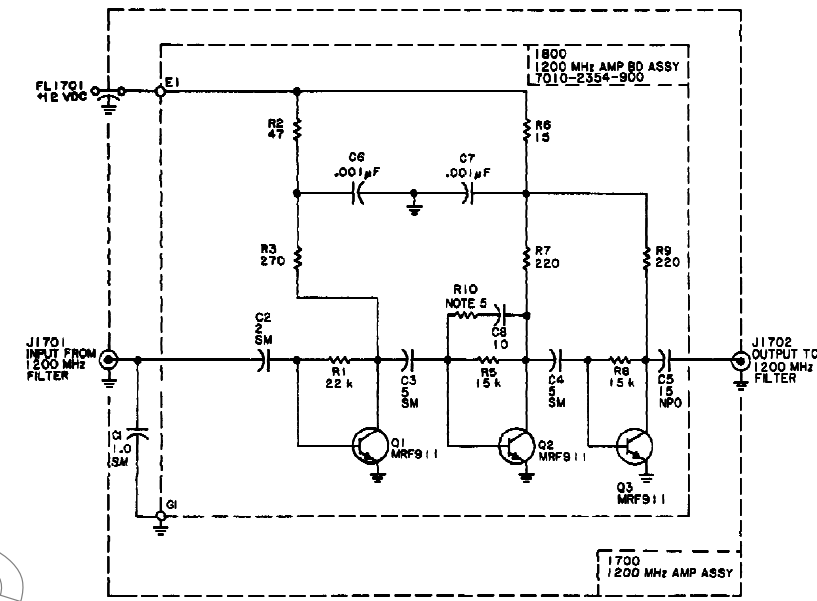


Figure 6-13. 1200 MHz amplifier A1A6, schematic diagram.

http://www.drafttools.com

NOTES:

- 1. LAST REF NO USED:  
AIA7C2  
AIA7CR8  
AIA7FL1  
AIA7J2  
AIA7L2  
AIA7R4

2. ALL RESISTORS ARE 1/4 W, 10%.

3. ALL RESISTANCE IS EXPRESSED IN OHMS UNLESS OTHERWISE NOTED.

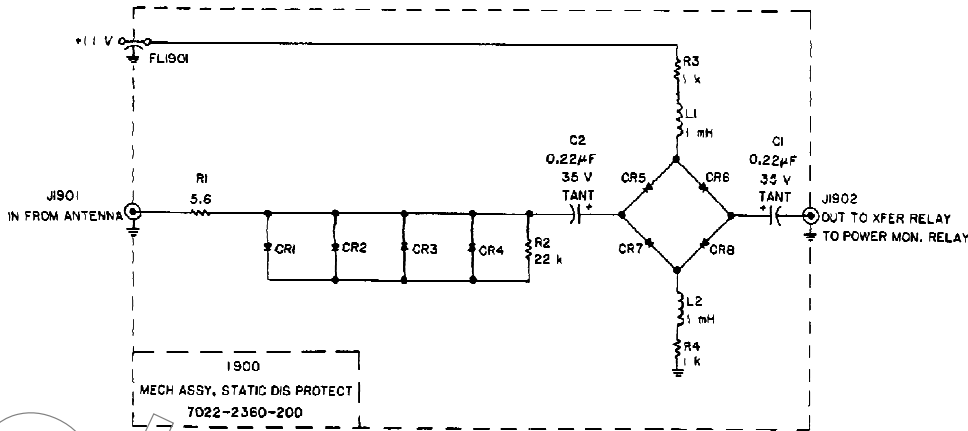
4. ALL DIODES ARE MA-47047.

5. ALL REF NO'S CARRY AN ASSIGNED DESIGNATOR SERIES (e.g., THIS SCHEMATIC CARRIES SERIES AIA7; THEREFORE, R/S DESIGNATED AIA7R).

DRAFTSMAN NOTES:

ON SH 1 J1901 BECOMES AIA7J1  
J1902 AIA7J2  
FL1901 AIA7FL1

AIA7  
MECH ASSY  
STATIC DIS PROTECT  
7022-2360-200



1900  
MECH ASSY, STATIC DIS PROTECT  
7022-2360-200

Figure 6-14. Static discharge protector A1A7, schematic diagram.

http://www.pdatschools.com

A1A8  
MECH ASSY, REAR PANEL  
7003-2338-001

A1A8A1  
DUTY CYCLE REGULATOR ASSY  
7023-2338-400

NOTES:  
1. LAST REF NO USED:  
A1A8A1 R2  
R2 T1  
R3 TR1  
F3 A1A8A1P1  
G4 A1A8A1U1  
J2 A1A8A1G1  
A1A8A1J1

2. ALL REF NOS CARRY AN ASSIGNED DESIGNATOR  
SERIES (A). THIS SCHEMATIC CARRIES SERIES A1A8A1  
THEREFORE R1 IS DESIGNATED A1A8A1R1.

DRAFTSMAN NOTES:  
ON SHT 1 J2001 BECOMES A1A8J1  
J2002 A1A8J2  
J2003 A1A8A1U1  
PS100 A1A8A1P1  
J2301 A1A8A1J1  
G2101 A1A8A1G1  
AT2001-W A1A8A1W1  
AT2001-WE A1A8A1WE1

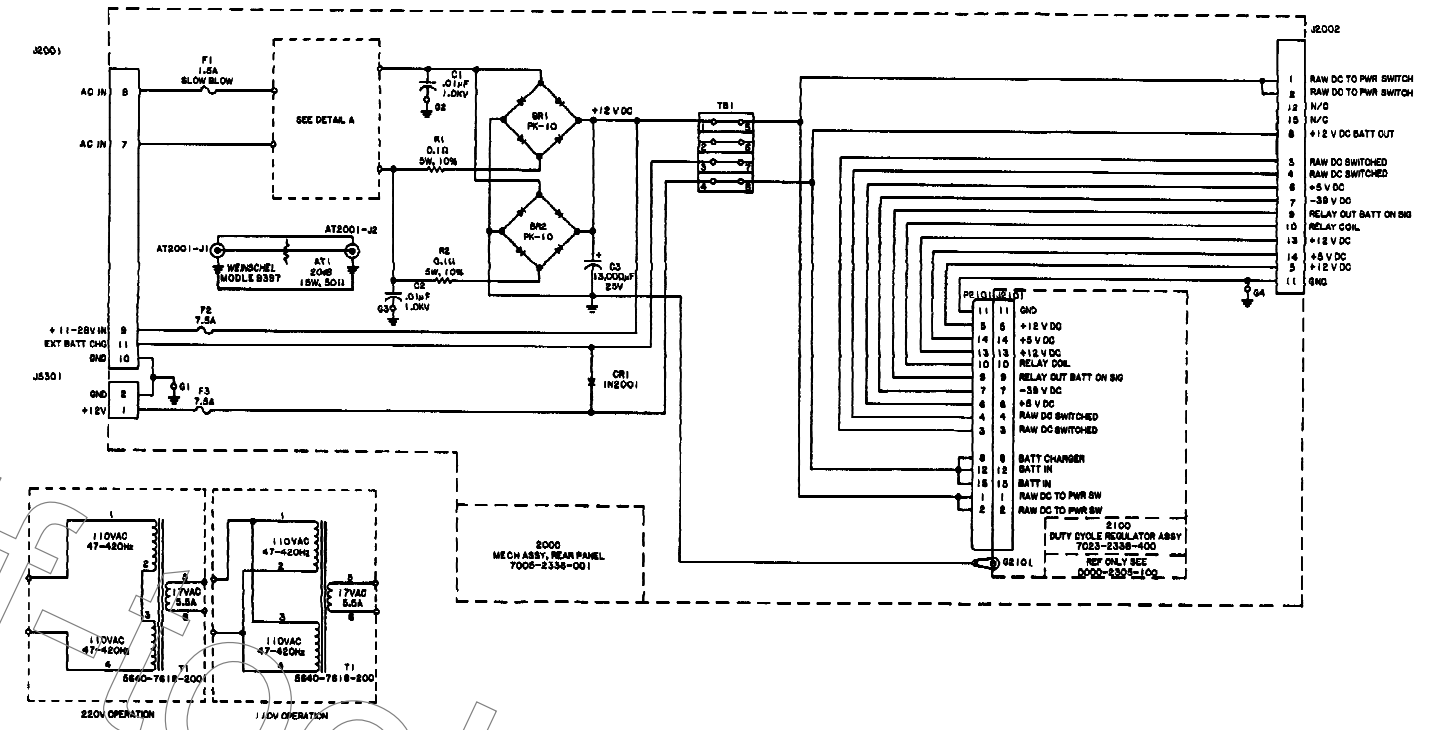


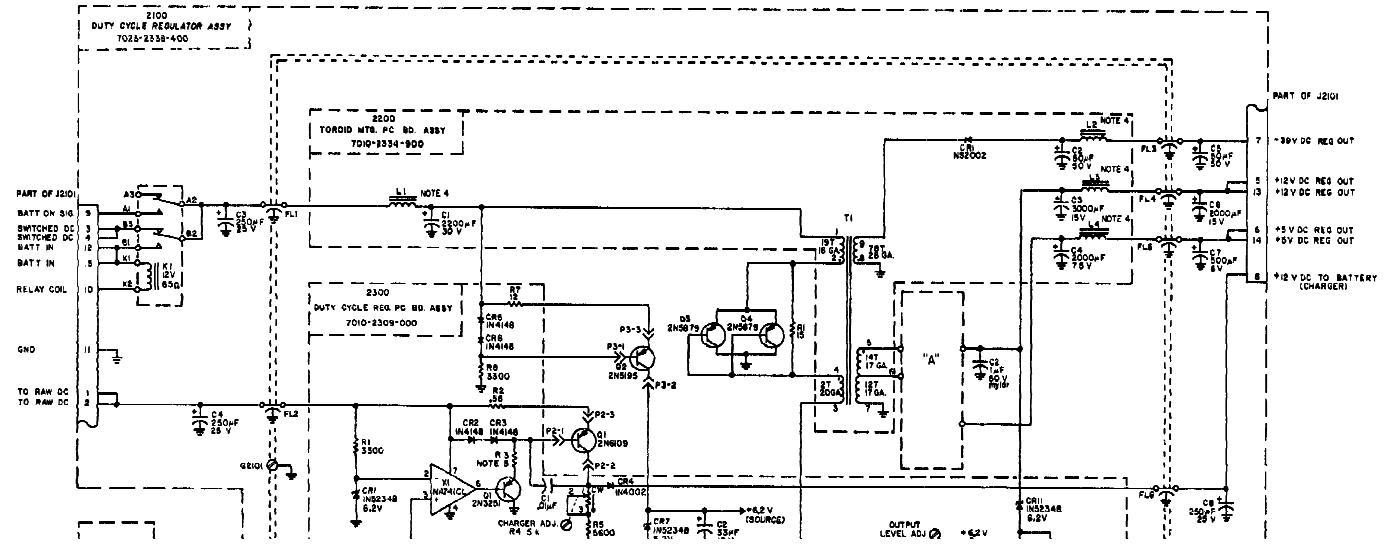
Figure 6-15. Rear panel assembly A1A8, schematic diagram.

NOTES:

1. LAST REF NO USED:  
 A1A8A1C5  
 CR6  
 FL6  
 J1  
 K1  
 P3  
 G3  
 R1  
 A1A8A1A1C4  
 CR1  
 L4  
 A1A8A1A1C6  
 CR2  
 CR3  
 R24  
 R2302
2. ALL RESISTORS ARE 1/4 W, 10% UNLESS OTHERWISE NOTED.
3. ALL RESISTANCE IS EXPRESSED IN OHMS UNLESS OTHERWISE NOTED.
4. L1, L2, L3 & L4 ARE 25 TURNS OF 17GA WIRE ON "MAGNETICS" 55950-A2 CORE.
5. R3 IS:  
 470, 1/4 W FOR S1801 THRU S1830.  
 560, 1/4 W FOR S1831 THRU S1839.

DRAFTSMAN NOTES:

- ON SMT 1 J2101 BECOMES AIRBAU1  
 02101 AIRBAU1
- AIRBAU1  
 DUTY CYCLE REGULATOR ASSY  
 7023-2338-400
- AIRBAU1  
 DUTY CYCLE REG. P.C. BD. ASSY  
 7010-2334-800
- AIRBAU1  
 TOROID MFG. P.C. BD. ASSY  
 7010-2334-800



**TECHNICAL MANUAL**

**OPERATOR'S, ORGANIZATIONAL,  
DIRECT SUPPORT,  
AND GENERAL SUPPORT MAINTENANCE  
MANUAL**

**TEST SET, RADIO AN/GRM-114  
(NSN 6625-01-108-6206)**