



LEICA S3

Instruction manual

FOREWORD

Dear Customer,
We wish you a great deal of fun and success taking photographs with your new Leica S3. Please read this manual thoroughly to ensure that you familiarize yourself with the full scope of functions your camera has to offer.

Your Leica Camera AG

SCOPE OF DELIVERY

Before using your camera for the first time, please check that the accessories supplied are complete.

- Leica S3
- Camera bayonet cover
- Eyepiece cover
- Lithium-ion battery Leica BP-PRO 1
- Quick action charger Leica S3
- Flash sync cable with adapter
- USB 3.0 cable
- Carry strap
- Quick Start Guide
- CE flyer
- Creative Cloud flyer
- Test certificate

REPLACEMENT PARTS/ACCESSORIES

Please contact Leica Customer Care or visit the Leica Camera AG website for information on the extensive range of Leica replacement parts/accessories:

en.leica-camera.com/Photography/Leica-S/Technical-Equipment

Only the accessories specified and described in this manual or by Leica Camera AG must be used with the camera (battery, charger, mains plug, mains cable, etc.). These accessories should only be used with this product. Third-party accessories may result in malfunctions or damage to the product.

Please read the chapters “Legal information”, “Safety remarks”, and “General information” before using your camera for the first time. Knowledge of the content will prevent inadvertent damage to the product, possible injuries and other risks.

LEGAL INFORMATION

LEGAL INFORMATION

- Compliance with copyright laws is mandatory. The recording and publication of pre-recorded media like tapes, CDs or other published or broadcast material may breach copyright laws.
- The following applies for all video material created with this camera: This product is governed by the AVC Patent Portfolio license and is meant for private use by a consumer only. The device may furthermore be used for purposes for which the consumer receives no remuneration, e.g. (i) encoding in accordance with the AVC Standard (“AVC Video”) and/or (ii) decoding of AVC Video that was encoded by a consumer in accordance with the AVC Standard within the scope of personal use and/or which the consumer has received from the provider, who is in possession of a license to offer AVC Video. No license is granted or implied for any other use. Any other use, specifically the provision of AVC video in exchange for remuneration, may require a separate license agreement with MPEG LA, L.L.C. Please visit the MPEG LA, L.L.C. website at: www.mpegla.com for more information.

REGULATORY INFORMATION

You will find the manufacturing date of your camera on the stickers on the packaging. The date format is year/month/day.

Specific regional approvals for this device can be found in the camera menu.

- ▶ Select **SETUP** (Press BR button **15**)
- ▶ Select **Camera Information** in the main menu
- ▶ Select **Regulatory Information** in the submenu

The CE mark on our products documents compliance with the fundamental requirements of applicable EU guidelines.

English		
Declaration of Conformity (DoC)		
Hereby, "Leica Camera AG" declares that this product is in compliance with the essential requirements and other relevant provisions of Directive 2014/53/EU.		
Customers can download a copy of the original DoC to our RE products from our DoC server:		
www.cert.leica-camera.com		
In case of further questions, please contact:		
Leica Camera AG, Am Leitz-Park 5, 35578 Wetzlar, Germany		
Type of wireless	Frequency band (central frequency)	Maximum power (dBm e.i.r.p.)
WLAN	2412 – 2462 MHz/	10.0
	5180 – 5240 MHz/	
	5260 – 5320 MHz/	6.5
	5500 – 5700 MHz	
Bluetooth	2402 - 2480 MHz	7.0

FOR US ONLY:

FCC NOTE:

This equipment has been tested and found to comply with the limits for a Class B digital device, pursuant to Part 15 of the FCC Rules. These limits are designed to provide reasonable protection against harmful interference in a residential installation. This equipment generates, uses, and can radiate radio frequency energy and, if not installed and used in accordance with the instructions, may cause harmful interference to radio communications. However, there is no guarantee that interference will not occur in a particular installation. If this equipment does cause harmful interference to radio or television reception, which can be determined by turning the equipment off and on, the user is encouraged to try to correct the interference by one or more of the following measures:

- Reorient or relocate the receiving antenna.
- Increase the separation between the equipment and receiver.
- Connect the equipment into an outlet on a circuit different from that to which the receiver is connected.
- Consult the dealer or an experienced radio/TV technician for help.

FCC CAUTION:

To assure continued compliance, follow the attached installation instructions and use only shielded interface cables with ferrite core when connecting to computer or peripheral devices. Any changes or modifications not expressly approved by the party responsible for compliance could void the user's authority to operate this equipment.

Declaration of Conformity

Trade Name: Leica
 Model No.: 6847
 Responsible party/Support contact:
 Leica Camera Inc.
 1 Pearl Court, Unit A
 Allendale, New Jersey 07401
 Tel.: +1 201 995 0051
 Fax: +1 201 995 1684
 technicalinfo@leicacamerausa.com

Type No.: 6847

FC Tested To Comply
 With FCC Standards
 FOR HOME OR OFFICE USE

This device complies with Part 15 of the FCC Rules. Operation is subject to the following two conditions: (1) This device may not cause harmful interference, and (2) this device must accept any interference received, including interference that may cause undesired operation.

FCC ID: N5A6847

This transmitter must not be co-located or operated in conjunction with any other antenna or transmitter. This equipment complies with FCC radiation exposure limits set forth for an uncontrolled environment and meets the FCC radio frequency (RF) Exposure Guidelines. This equipment is tested for specific absorption ratio (SAR) and complies with FCC/IC radiation exposure limits set forth for an uncontrolled environment. This device complies with FCC/IC SAR limit of 1.6 W/kg. For body worn operation, this equipment has been tested and meets the FCC/IC RF exposure guidelines when used with the Leica Camera AG accessories supplied or designated for this product that have no metallic component in the assembly. Use of other accessories may not ensure compliance with FCC/IC RF exposure guidelines.

FOR CANADA ONLY:

CAN ICES-3 (B)/NMB-3(B)

This device complies with RSS-210 of the IC Rules.

Operation is subject to the following two conditions:

- (1) This device may not cause harmful interference,
- (2) This device must accept any interference received, including interference that may cause undesired operation of the device. This equipment complies with IC radiation exposure limits set forth for an uncontrolled environment and meets RSS-102 of the IC radio frequency (RF) Exposure rules.

This equipment is tested for specific absorption ratio (SAR) and complies with FCC/IC radiation exposure limits set forth for an uncontrolled environment. This device complies with FCC/IC SAR limit of 1.6 W/kg. For body worn operation, this equipment has been tested and meets the FCC/IC RF exposure guidelines when used with the Leica Camera AG accessories supplied or designated for this product that have no metallic component in the assembly. Use of other accessories may not ensure compliance with FCC/IC RF exposure guidelines.

FOR UNITED ARAB EMIRATES ONLY:

REGISTERED No:
 ER67106/18
 DEALER No:
 DA0112968/13



DISPOSAL OF ELECTRICAL AND ELECTRONIC EQUIPMENT

(Applies within the EU and for other European countries with active waste separation policies)

This device contains electric and/or electronic components which must not be disposed of in general household waste. Instead, it should be disposed of at a recycling collection point provided by your local authority. This service is free of charge. Any standard or rechargeable batteries used in this device must be removed and disposed of separately in accordance with local regulations.

Please contact your local authorities, waste disposal collection point or the retailer, from whom you purchased the device for more information on correct waste disposal.

IMPORTANT NOTES REGARDING THE USE OF GPS

Legal restrictions on use

- The use of GPS and associated technologies may be restricted in some countries or regions.
- You should therefore contact your travel agent or the embassy of your destination country for relevant information beforehand.
- The People's Republic of China and Cuba (exceptions: Hong Kong and Macao) prohibit the use of GPS within their territories and in the vicinity of their borders.

Violations will be prosecuted!

Notes on function

- Prerequisite for GPS triangulation is "Line of Sight" (LoS) to at least 3 GPS satellites (up to 9 of the total 24 GPS satellites are available from any point on Earth at all times). The camera should therefore always be held with the GPS antenna pointing straight upwards.
- Make sure not to cover the GPS antenna with your hand or any object (specifically metallic objects).
- Perfect signal reception from GPS satellites may be impossible in the following locations or under the circumstances listed below. Geo-location may then be impossible or erratic at best.
 - in enclosed spaces
 - underground
 - under trees
 - in a moving vehicle
 - in the vicinity of tall buildings or in narrow valleys
 - in the vicinity of high-voltage lines
 - in tunnels
 - in the vicinity of mobile phones
 - with an accessory attached to the flash shoe, e.g. a flash unit

We recommend recommissioning the GPS function in a location with good signal reception if the camera has not been used for an extended period of time.

Notes on safe use

The electromagnetic radiation generated by the GPS system may affect electronic instruments and measuring devices. Make sure to disable the GPS function on board an aircraft before takeoff or landing, in hospitals and other locations where RF restrictions apply.

IMPORTANT NOTES REGARDING THE USE OF WLAN (LEICA FOTOS)

- Appropriate measures must be taken to ensure security and protect against disruptions to the systems in place where devices or computer systems are in use that require more stringent security than WLAN devices.
- Leica Camera AG shall not accept liability for damages arising from the use of the camera for purposes other than as a WLAN device.
- It is assumed that the WLAN function will be used in countries where this camera is sold. There may be a risk of breaching statutory wireless communication regulations when using the camera in other countries. Leica Camera AG shall not accept liability for such breaches.
- Please note that there is a risk of unauthorized third party interception of wirelessly communicated data. We highly recommend that you activate encryption in the wireless access point settings to ensure data safety.
- Avoid using the camera in areas where it can be exposed to magnetic fields, static electricity or other interferences, e.g. near a microwave oven. RF transmissions may otherwise not reach the camera.
- Using the camera near devices like microwave ovens or wireless phones that use the 2.4 GHz RF band may negatively affect the performance of both devices.
- Do not attempt to connect to wireless networks you are not authorized to use.
- The device will automatically search for wireless networks, once the WLAN function is enabled. A list, including networks you are not authorized to access, will be displayed (SSID: Network identifier for a WLAN network). Do not attempt to connect to such a network, as this could be construed as unauthorized access.
- We recommend disabling the WLAN function while on an aircraft.

SAFETY REMARKS

GENERAL INFORMATION

- Do not use your camera in the immediate vicinity of devices that generate powerful magnetic, electrostatic or electromagnetic fields (e.g. induction ovens, microwave ovens, television sets or computer screens, video game consoles, cell phones, broadcasting equipment). Their electromagnetic fields can interfere with recordings.
- Strong magnetic fields, e.g. from speakers or large electric motors can damage the stored picture data or disrupt recording.
- Switch off the camera, remove the battery briefly, replace it and switch the camera back on in case of a camera malfunction due to the effects of electromagnetic fields.
- Do not use the camera in the immediate vicinity of radio transmitters or high-voltage power lines. Their electromagnetic fields may interfere with recordings.
- Always store small parts e.g. the accessory shoe cover as follows:
 - out of the reach of children
 - in a safe location, where they will not get lost or stolen
- State-of-the-art electronic components are sensitive to static discharge. You can easily pick up charges of several 10,000 volts by simply walking on synthetic floor coverings. A static discharge can occur when you touch the camera and especially if it is placed on a conductive surface. A static discharge on the camera housing poses no risk for the electronics. Despite built-in safety circuits, you should avoid direct contact with external camera contacts like those in the flash shoe.
- Take care not to soil or scratch the sensor for lens detection in the bayonet. You must similarly prevent direct contact of the bayonet with grains of sand or similar particles, as these could cause irreparable damage. This component must only be cleaned with a dry cloth (in system cameras).
- Use a cotton or linen cloth instead of a microfiber cloth from an optician's (synthetic) when cleaning the contacts. Make sure to discharge any electrostatic charge by deliberately touching a heating or water pipe (conductive, grounded material). Dirt deposits and oxidation on the contacts can be avoided by storing your camera in a dry location with the lens cap and the flash shoe/viewfinder cap (in system cameras) attached.
- Only use accessories specified for this model to prevent faults, short circuits or electric shock.
- Do not attempt to remove parts of the housing (covers) yourself. Repairs must be done at authorized service centers only.
- Protect the camera against contact with insect sprays and other aggressive chemicals. Petroleum spirit, thinner and alcohol must not

be used for cleaning. Some chemicals and liquids can damage the camera housing or the surface finish.

- Rubber and plastics are known to expel aggressive chemicals and should therefore not be kept in contact with the camera for extended periods of time.
- Prevent any sand or dust or water penetration into the camera, e.g. during snowfall or rain or on the beach. Be extra careful when changing the lens (in system cameras) and when inserting or removing the memory card and rechargeable battery. Sand and dust can damage the camera, the lens, the memory card and the battery. Moisture can cause malfunctions and irreparable damage to the camera and memory card.

LENS

- A camera lens can have the effect of a magnifying glass when exposed to direct frontal sunlight. The camera must therefore be protected against extended exposure to direct sunlight.
- Attaching the lens cap and keeping the camera in the shade or ideally in its camera case, will help prevent damage to the interior of the camera.

RECHARGEABLE BATTERY

- Improper use of the batteries or the use of unapproved battery types may result in an explosion!
- Do not expose the rechargeable battery to sunlight, heat, humidity or moisture for prolonged periods of time. Likewise, the batteries must not be placed in a microwave oven or a high-pressure container as this would pose a fire or explosion hazard.
- Do not under any circumstances charge or insert a damp or wet battery into the camera!
- A safety valve in the battery ensures that any excess pressure caused by improper handling is discharged safely. It is nevertheless important to dispose of a bloated battery immediately. It may pose an explosion hazard!
- Keep the battery contacts clean and easily accessible. Although lithium-ion batteries are secured against short circuits, they should still be protected against contact with metal objects like paper clips or jewelry. A short-circuited battery can get very hot and cause severe burns.
- When a battery is accidentally dropped, make sure to check the housing and the contacts immediately for any damage. A damaged battery can damage the camera.
- The battery must be removed from the camera or charger and must be replaced immediately in case of a strange smell, discoloration, deformation, overheating or leakage. Continued use of the battery may result in overheating, which can cause fire and/or explosion!

- Never throw batteries into a fire as they may explode.
- Keep the battery away from sources of heat in case of leakage or if you smell burning. Leaked fluid can catch fire!
- The use of other chargers not approved by Leica Camera AG can cause damage to the batteries – and in extreme cases – cause serious or life-threatening injuries.
- Make sure that the power socket is freely accessible at all times.
- Do not attempt to open the battery or the charger. Repairs must only be carried out by authorized service centers.
- Keep batteries out of the reach of children. Batteries can cause suffocation when swallowed.

FIRST AID

- Battery fluid may cause blindness if it comes into contact with the eyes. Rinse the eyes thoroughly with clean water immediately. Avoid rubbing. Seek medical attention immediately.
- Leaked battery fluid poses an injury hazard when it comes in contact with clothing or skin. Rinse the affected areas thoroughly with clean water.

CHARGER

- Using the charger in the vicinity of broadcasting receivers may interfere with reception. Ensure a distance of at least 1 m (3 ft) between the charger and the receiver.
- When the charger is in use, it may emit a buzzing sound – this is normal and not a malfunction.
- Disconnect the charger from the mains when it is not in use, as it consumes electricity (a very small amount), even if no battery is inserted.
- Always keep the charger contacts clean, and never short circuit them.

MEMORY CARD

- Never remove the memory card during a datasave or card reading process. The camera must not be switched off or be subjected to impact or vibrations while working.
- Do not open the cover/remove the memory card or the battery while the status LED is lit, which indicates memory access. Data on the card may otherwise be destroyed and camera malfunctions may occur.
- Do not drop or bend memory cards as this will cause damage and result in the loss of stored data.

- Do not touch the connections on the reverse of the memory card and keep them clean and dry.
- Keep memory cards out of the reach of children. Swallowing a memory card may cause suffocation.

SENSOR

Cosmic radiation (e.g. during flights) may cause pixel defects.

CARRY STRAP

- Carry straps are usually made of very robust material. You should therefore keep it out of the reach of children. A carry strap is not a toy and poses a strangulation risk.
- Use the carry strap only for its intended purpose on a camera or on binoculars. Any other use poses the risk of injury and may possibly result in damage to the carry strap and is therefore not permitted.
- Carry straps should also not be used for cameras/binoculars during sports activities that pose a risk of entanglement (e.g. when mountain climbing and similar outdoor activities).

Please read the section about “Care/Maintenance” for more information about what to do in case of problems.

GENERAL INFORMATION

CAMERA/LENS

- Make a note of the serial numbers of your camera (engraved in the base of the camera housing) and lenses, as this information will be extremely important in case of loss.
- Make sure to always have a lens or the camera bayonet cover attached to prevent dust or other foreign bodies penetrating the camera.
- That is why you should always replace lenses quickly and in a dust-free environment.
- Never store the camera bayonet cover or the lens back cover in a pants pocket, as they will attract lint and dust, which could then be accidentally introduced into the camera.
- Leica releases firmware updates for lenses at irregular intervals. You can download any new firmware version from our homepage and transfer it to your lens. Please read the section "Installing firmware" (p. 61) for more information.

LCD PANEL

- Condensation may form on the LCD panel if the camera is exposed to great temperature fluctuations. Wipe the screen carefully with a soft, dry cloth.
- The screen image will initially be slightly darker than normal if the camera is very cold when it is switched on. The normal level of brightness will be reached as soon as the LCD panel warms up.

RECHARGEABLE BATTERY

- The battery must have a temperature between + 10°C and + 30°C for charging, as the charger will otherwise not switch on or will switch off again.
- Lithium-ion batteries can be charged at any time, regardless of their current charge level. A partially charged battery will charge to full capacity faster than a fully discharged one.
- The rechargeable batteries come only partly charged ex works and should therefore be charged fully before their first use.
- A new battery only reaches its full capacity after it has been fully charged and – by using it in the camera – depleted 2 to 3 times. This depletion process should be repeated roughly every 25 cycles.
- Battery and charger heat up during the charging process. That is normal and not a malfunction.

- Rapid flashing of the two LEDs (> 2 Hz) when charging commences indicates a charging error (e.g. maximum charging time exceeded, voltages or temperatures outside permitted ranges or a short circuit). Disconnect the charger from the mains and remove the battery. Ensure that the above temperature conditions are met and then restart the charging process. Please contact your dealer, the Leica office in your country or Leica Camera AG if the problem persists.
- Rechargeable lithium-ion batteries generate power by way of internal chemical reactions. These reactions are influenced by ambient temperature and humidity. To ensure a maximum service life of the battery, it should not be exposed to extreme temperatures (high or low) for extended periods of time (e.g. in a parked car in the summer or winter).
- However, every battery has a limited service life! After several hundred charging cycles, this limitation will become evident as the operating times get significantly shorter.
- The replaceable battery supplies power to a backup battery, which is permanently installed in the camera. This backup battery retains the date and time for some weeks. Once the backup battery is depleted, it must be replenished by inserting a charged main battery. The time and date will have to be set again after a full depletion of both batteries.
- As the battery capacity deteriorates or if using an older battery, warning messages may appear and some functions may be restricted or blocked entirely.
- Remove the battery if the camera will not be used for an extended period of time. Make sure to switch the camera off via the main switch before removing the battery. Leaving the battery in the camera will result in a deep discharge after a few weeks. Voltage levels will decrease significantly, as the camera uses a low idle current to maintain settings.
- Dispose of damaged batteries in accordance with the relevant regulations at an approved collection point for proper recycling.
- The date of manufacture can be found on the battery. The date format is week/year.

MEMORY CARD

- The range of available SD/SDHC/SDXC cards on the market is too extensive for Leica Camera AG to test for compatibility and quality. Generally, any type of memory card may be used without any damage to the camera or memory card. As some "no name" cards may not fully comply with the SD/SDHC/SDXC standards, Leica Camera AG cannot provide any guarantee of function.
- We recommend formatting memory cards from time to time, because fragmented residual data from deleted files may block some of the storage capacity.
- Generally, it is not necessary to format (initialize) memory cards that have been previously used. Formatting will, however, be necessary if you insert an unformatted memory card or a card that was formatted in another device (e.g. a computer) for the first time.
- We recommend backing up your data on a PC, because electromagnetic fields, static electricity and any memory card or camera defects could result in permanent damage or loss of your data.
- SD, SDHC, and SDXC memory cards come with a write protection slider to prevent accidental overwriting. This slider is located on the non-beveled side of the card. All data on the card is protected when the slider is set to its lower position, marked LOCK.

SENSOR

- Any dust or dirt particles stuck to the glass cover of the sensor may result in noticeable dark stains or specks on the pictures.

DATA

- All data, including personal information, may be changed or deleted due to incorrect or accidental operation, static discharge, accidents, malfunctions, repairs and other measures.
- Please note that Leica Camera AG does not accept liability for direct or consequential damage due to the manipulation or destruction of data and personal information.

FIRMWARE UPDATE

Leica is constantly working on developing and optimizing the Leica S3. As many functions on digital cameras are controlled purely electronically, improvements and extensions to the range of functions may need to be installed on the camera at a later date. Leica releases what are known as firmware updates at irregular intervals. Cameras are always supplied from the factory with the latest firmware. Otherwise you can download it from our website yourself and transfer it to your camera.

You will receive a newsletter informing you of the availability of a new firmware update if you register your camera on the Leica Camera homepage.

Visit the download section or the "Customer Area" for information about how to register or how to get firmware updates for your Leica S3.

Additionally, you can find information about changes or additions to the manual at:

<https://owners.leica-camera.com>

Select menu item "Firmware" (see p. 7) to check whether your camera and lenses are running the latest firmware version.

WARRANTY

In addition to your statutory warranty rights regarding your dealer, you will receive an additional Leica Camera AG product warranty valid from the date of purchase at an authorized Leica retailer. For more information regarding the warranty scope, warranty services and limitations, please visit:

warranty.leica-camera.com

Definition of the various categories of information found in this manual

Note

Additional information

Important

Failure to observe the instructions may result in damage to the camera, the accessories or the pictures.

Attention

Non-compliance may result in personal injury

INHALTSVERZEICHNIS

FOREWORD	2	SD/SDHC/SDXC CARDS	21	BASIC PICTURE SETTINGS	32
SCOPE OF DELIVERY	2	CHANGING THE FOCUSING SCREEN	22	PHOTO	32
REPLACEMENT PARTS/ACCESSORIES	2	COMPATIBLE LENSES	22	FILE FORMAT	32
LEGAL INFORMATION	2	LEICA S LENSES	22	JPG COLOR SPACE	32
LEGAL INFORMATION	2	ATTACHING/DETACHING LENSES	23	JPG RESOLUTION	32
REGULATORY INFORMATION	3	DIOPTR SETTINGS	23	IMAGE PROPERTIES	32
DISPOSAL OF ELECTRICAL AND ELECTRONIC EQUIPMENT	3	CAMERA OPERATION	24	CONTRAST	32
IMPORTANT NOTES REGARDING THE USE OF GPS	3	OPERATING ELEMENTS	24	SHARPNESS	32
SAFETY REMARKS	4	MAIN SWITCH	24	COLOR SATURATION	33
GENERAL INFORMATION	6	SHUTTER BUTTON	24	MONOCHROME RECORDINGS	33
WARRANTY	7	DEPTH-OF-FIELD PREVIEW BUTTON	25	MEMORY CARD MANAGEMENT	33
PART DESIGNATIONS	10	MENU CONTROL	26	PICTURE MODE (FOTO)	34
CAMERA	10	CONTROL ELEMENTS	26	LIVE VIEW MODE	34
LENS*	11	STRUCTURE OF THE MENU SCREEN	26	FOCUSING	34
DISPLAYS	12	FUNCTION GROUPS	26	FOCUS METERING METHODS	34
VIEWFINDER	12	MAIN MENU	26	AFS (SINGLE)	34
TOP DISPLAY	13	SUBMENU	26	AF-C (CONTINUOUS)	34
START SCREEN	13	SHOW MENU PAGES	27	MANUAL FOCUSING	35
STANDARD VIEW	13	SHOW FUNCTION GROUP	27	ASSIST FUNCTIONS FOR MANUAL FOCUSING IN LIVE VIEW MODE	35
DEPTH OF FIELD DISPLAY	13	(ACCESS TO MENU CONTROL)	27	ENLARGEMENT	35
DISPLAY WHEN SETTING EXPOSURE MODE	13	SHOW SUBMENU	27	FOCUS PEAKING	35
LCD PANEL	14	MENU NAVIGATION	27	ISO SENSITIVITY	36
WHEN TAKING A PICTURE	14	NAVIGATING WITHIN THE MENUS	27	WHITE BALANCE	36
INFO DISPLAY	14	CONFIRM SELECTION	27	AUTOMATIC CONTROL/FIXED SETTINGS	36
IN LIVE VIEW MODE	14	GO BACK ONE STEP (LEAVE SUBMENU)	27	DIRECT SETTING OF THE COLOR TEMPERATURE	37
VIDEO	14	EXITING THE MENU	27	MANUAL SETTING AFTER MEASUREMENT	37
IN PLAYBACK MODE	16	KEYPAD SUBMENU OPERATION	28	EXPOSURE	38
PHOTO	16	OPERATING THE NUMBER PAD SUBMENU	28	EXPOSURE METERING METHODS	38
VIDEO	16	QUICK ACCESS (SHORT CUT)	28	SPOT METERING	38
PREPARATION	18	MANAGE QUICK ACCESS	29	CENTER-WEIGHTED METERING	38
ATTACHING THE CARRY STRAP	18	ACCESSING A QUICK ACCESS MENU ITEM	29	MULTI-FIELD METERING	38
PREPARING THE CHARGER	18	BASIC CAMERA SETTINGS	30	SHIFTING THE AF/SPOT METERING FIELD IN LIVE VIEW MODE	38
FOR USE OUTSIDE THE US	18	MENU LANGUAGE	30	VALUES ABOVE/BELOW THE MEASURING RANGE	38
FOR USE IN THE US	18	DATE/TIME	30	EXPOSURE MODES	38
CHARGING THE BATTERY	19	DATE	30	AUTOMATIC PROGRAM - P	39
CHARGE STATUS INDICATORS ON THE CHARGER	19	TIME	30	PROGRAM SHIFT	39
INSERTING/REMOVING THE BATTERY	19	AUTOMATIC TIME VIA GPS	30	APERTURE PRIORITY - A	39
CHARGE LEVEL DISPLAY ON THE LCD PANEL	20	TIME ZONE	30	SHUTTER SPEED PRIORITY - T	40
INSERTION/REMOVAL OF MEMORY CARDS	20	DAYLIGHT SAVING TIME	30	MANUAL SETTING OF APERTURE AND EXPOSURE TIME - M	40
CF CARDS	20	AUTO POWER SAVING (STANDBY MODE)	30	EXPOSURE CONTROL/FUNCTIONS FOR AUTOMATIC EXPOSURE	40
		ACOUSTIC SIGNALS	31	EXPOSURE SIMULATION	40
		VOLUME	31	METERING MEMORY LOCK	41
		LCD PANEL/TOP DISPLAY/VIEWFINDER SETTINGS	31	EXPOSURE COMPENSATION	42
		BRIGHTNESS	31	AUTOMATIC BRACKETING	42
		INFORMATION DISPLAYS	31	LONG-TERM EXPOSURE (B)	43
				OTHER FUNCTIONS	43
				DEPTH OF FIELD	43

AUXILIARY DISPLAYS IN LIVE VIEW MODE.....	43	TAKING PHOTOGRAPHS DURING A VIDEO RECORDING.....	51	MENU OVERVIEW.....	64
HISTOGRAM.....	43	PLAYBACK/REVIEW MODE.....	52	INDEX.....	66
GRID LINES.....	43	PHOTO REVIEW.....	52	TECHNICAL DATA.....	68
CLIPPING.....	44	PICTURE REVIEW.....	52	LEICA CUSTOMER CARE.....	70
HORIZON.....	44	AUTOMATIC REVIEW OF THE LAST RECORDING.....	52	LEICA ACADEMY.....	70
MIRROR UP MODE.....	44	VIDEO PLAYBACK.....	52		
FRAME.....	45	DISPLAYS IN PLAYBACK MODE.....	53		
SERIAL EXPOSURES.....	45	SELECTING/SCROLLING THROUGH RECORDINGS.....	54		
INTERVAL SHOOTING.....	46	CROPPED SECTION ZOOM.....	54		
SELF-TIMER.....	46	INCREMENTAL ENLARGEMENT.....	54		
FLASH PHOTOGRAPHY.....	47	MAX. ENLARGEMENT IN ONE STEP.....	54		
COMPATIBLE FLASH UNITS.....	47	MOVING THE CROPPED SECTION.....	55		
CONNECTION VIA FLASH SHOE.....	47	DISPLAYING MULTIPLE RECORDINGS AT ONCE.....	55		
CONNECTION VIA THE LOWER LEMO® JACK.....	47	MARKING/UNMARKING A RECORDING.....	55		
CONNECTION VIA THE FLASH CONNECTION JACK.....	47	DELETING A RECORDING.....	56		
ATTACHING THE FLASH UNIT.....	47	OTHER FUNCTIONS.....	58		
FLASH EXPOSURE METERING (TTL METERING).....	47	USER PROFILES.....	58		
FLASH MODES.....	48	SAVE CURRENT SETTING AS USER PROFILE.....	58		
AUTOMATIC (A).....	48	RENAMING PROFILES.....	58		
FLASH PHOTOGRAPHY WITH AUTOMATIC EXPOSURE.....	48	APPLY/ACTIVATE PROFILES.....	58		
HSS (HIGH SPEED SYNC.).....	48	EXPORTING/IMPORTING PROFILES TO/FROM THE MEMORY CARD.....	58		
FLASH CONTROL.....	48	DATA MANAGEMENT.....	58		
FLASH RANGE.....	48	DATA STRUCTURE ON THE MEMORY CARD.....	58		
SYNC POINT.....	48	FOLDER STRUCTURE.....	58		
FLASH SYNC SPEED.....	48	FILE STRUCTURE.....	58		
STROBOSCOPE FLASH MODE.....	49	EDIT FILE NAMES.....	59		
MANUAL FLASH PHOTOGRAPHY WITH UNIFORM FLASH OUTPUT.....	49	CREATING A NEW FOLDER.....	59		
FLASH PHOTOGRAPHY VIA THE LOWER LEMO® JACK.....	49	RESETTING IMAGE NUMBERING.....	59		
FLASH EXPOSURE DISPLAYS IN THE VIEWFINDER.....	49	ADDING COPYRIGHT INFORMATION.....	59		
VIDEO MODE.....	50	RECORDING THE IMAGE LOCATION WITH GPS.....	59		
STARTING/ENDING THE RECORDING.....	50	FORMATTING A MEMORY CARD.....	60		
VIDEO SETTINGS.....	50	DATA TRANSFER.....	60		
RESOLUTION.....	50	USING RAW DATA (DNG).....	60		
ISO SENSITIVITY.....	50	RESETTING THE CAMERA TO FACTORY SETTINGS.....	60		
IMAGE PROPERTIES.....	50	FIRMWARE UPDATES.....	61		
COLOR SPACE.....	50	EXECUTING A FIRMWARE UPDATE.....	61		
CONTRAST, SHARPNESS, SATURATION.....	50	CARE/STORAGE.....	62		
TIME CODE.....	50	CAMERA HOUSING.....	62		
EXPOSURE METERING METHODS.....	50	LENS.....	62		
EXPOSURE MODES.....	50	VIEWFINDER/LCD PANEL.....	62		
FOCUSING.....	50	RECHARGEABLE BATTERY.....	62		
AUDIO LEVEL.....	51	MEMORY CARDS.....	62		
MANUAL VOLUME ADJUSTMENT.....	51	SENSOR.....	63		
DEACTIVATE SOUND RECORDING.....	51	SENSOR CLEANING.....	63		
WIND NOISE DAMPING.....	51				
CHECKING THE SOUND RECORDING.....	51				
SETTING THE HEADPHONE VOLUME.....	51				

PART DESIGNATIONS

CAMERA

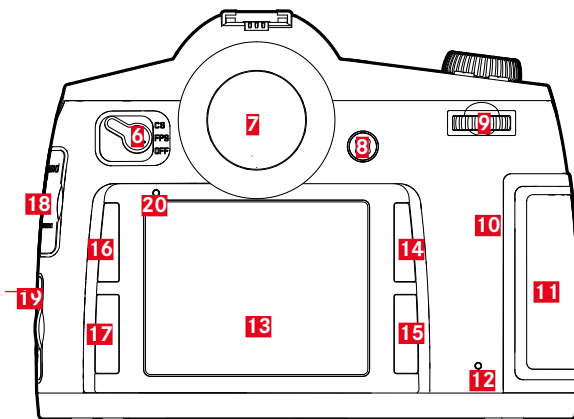
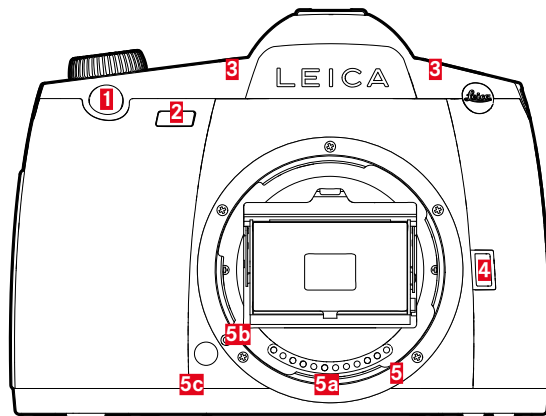

Front view

- 1 Shutter button
- 2 Self-timer LED/Sensor for white balance
- 3 Microphone
- 4 Depth of field preview / Function button
- 5 Bayonet
- a Contact strip
- b Alignment point for fitting the lens
- c Release button

Rear view

- 6 Main switch
- 7 Viewfinder
- 8 Joystick
- 9 Thumbwheel
- 10 Speaker
- 11 Cover for memory card slot (closed)
- 12 Picture/Recording and Datasave LED
- 13 LCD panel
- 14 Playback/Menu control/Function button (TR button = Top Right button)
- 15 Menu control/Function button (BR button = Bottom Right button)
- 16 Menu control/Function button (TL button = Top Left button)
- 17 Menu control/Function button (BL button = Bottom Left button)
- 18 Cover for LEMO® audio / HDMI jack
- 19 Cover for LEMO® USB 3.0 / Remote control / Flash synchronization jack
- 20 Brightness sensor for LCD panel

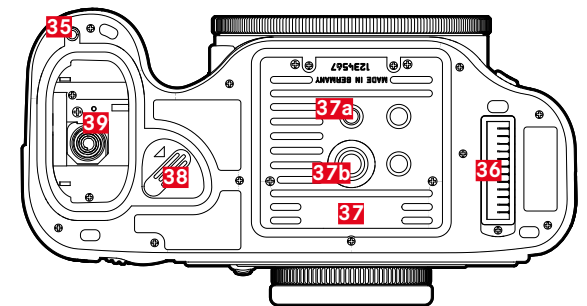
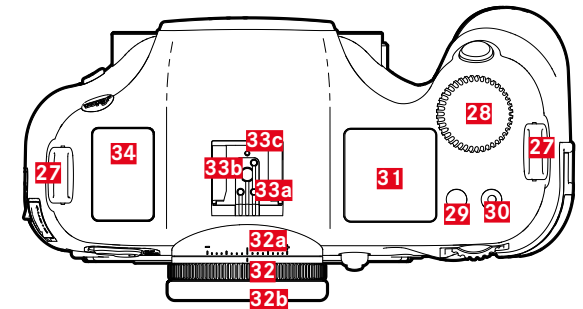
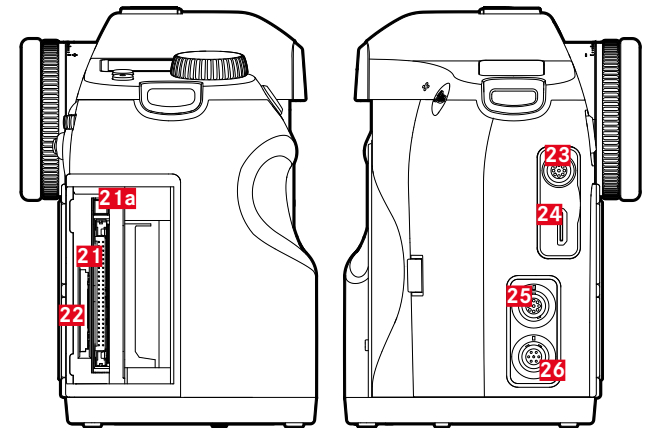

View from right

- 21** Memory card slot (CF)
- a** Ejector pin
- 22** Memory card slot (SD)

View from left

- 23** LEMO® audio jack
- 24** HDMI jack
- 25** LEMO® USB 3.0 jack
- 26** LEMO® Remote control / Flash synchronization jack

Top view

- 27** Carry strap attachment
- 28** Shutter speed setting wheel/Function wheel
- 29** Live View button (LV button)
- 30** Video button
- 31** Top display
- 32** Diopter dial
 - a** Scale
 - b** Eyecup
- 33** Accessory shoe
 - a** Center (firing) contact
 - b** Control contacts
 - c** Bore for locking pin
- 34** GPS antenna

Bottom view

(Cover removed)

- 35** Guide pin index hole for multifunction hand grip
- 36** Contact strip for multifunction hand grip
- 37** Tripod plate
 - a** 1/4" tripod thread
 - b** 3/8" tripod thread
- 38** Battery release lever
- 39** Battery compartment

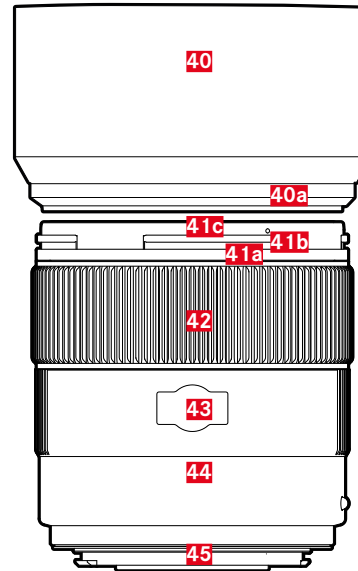
LENS*

- 40** Lens hood
 - a** Alignment point
- 41** Front mount
 - a** Male bayonet for lens hood
 - b** Alignment points for lens hood
 - c** Internal thread for filters
- 42** Focus ring
- 43** Distance scale window
- 44** Fixed ring
 - a** Red alignment button for lens change
- 45** Contact strip

*Representative image. Technical features may vary depending on model.

DISPLAYS

VIEWFINDER

**1** Horizon

(Tilt along the longitudinal axis/transverse axis; displays are provided as an example of tilting in a clockwise direction; other directions are displayed similarly)

- max. $\pm 0.5^\circ$
- $0.5\text{-}2.5^\circ$
- $2.5\text{-}5^\circ$
- $5\text{-}10^\circ$
- flashing $\geq 10^\circ$

2 Shutter speed

- manually set value at **m**/ **τ**
- automatically controlled value at **A**/**P**
- **H** (high) overexposure at **A**, **P**, **τ** or due to flash
- **L** (low) underexposure at **A**, **P**, **τ** or due to flash, undercutting of measuring range
- **b** Long-term exposure (**B** setting)
- **CARD** Memory card full warning

3 Exposure mode

- **P** Automatic program
- **A** Aperture priority
- **τ** Shutter priority mode
- **m** Manual settings for shutter speed and aperture

4 Aperture

- manually set value at **m**/**A**
- automatically controlled value at **τ** /**P**

5 Flash display

- Continuously lit: Flash ready
- Flashing: Flash loading, flash not ready

6 Light balance

(Markings: 1/2 EV increment each, last markings/digits flash at -3 EV/ $\geq +3$ EV) to show

- manual exposure balance
- Deviation of the current measurement to the saved exposure setting (with metering memory lock in the automatic exposure modes **A**, **P**, **τ**)
- Exposure compensation

7 Flash display

Illuminated = shutter speed \leq sync speed set

8 Focus displays

- only appears in manual mode or for manual AF override: continuously lit if setting is too large
- in manual mode: continuously lit if the setting is correct
 - for **AF**: continuously lit if the setting is correct; flashes if no correct setting is possible
 - for **AF**: continuously lit if the setting is correct; goes out when focusing restarts
- only appears in manual mode or for manual AF override: continuously lit if setting is too short

9 Exposure compensation/flash exposure compensation set**10** Exposure metering method

- Multi-field metering
- Center-weighted metering
- Spot metering

11 Picture counter

- **999** Total remaining number of pictures
- **USB** External memory
- **0** (flashing at 2 Hz) = memory card full
- **---** (flashing at 2 Hz) = no memory card inserted
- **L** Maximum number in a picture series (L 14)
- **Err** Error message

12 ISO sensitivity

- **ISO** manual setting
- **ISO** automatic setting
- **1600 H1** (ISO 3200)/**H2** (ISO 6400)/**H3** (ISO 12500)/**H4** (ISO 25000)/**H5** (ISO 50000) = currently set sensitivity

Note

The viewfinder LCD is always lit when the camera is switched on. The light level automatically adjusts to ambient brightness for reasons of legibility.

TOP DISPLAY

Start screen

(appears for approx. 5 s after camera is switched on)



Standard view



Depth of field display

(tap shutter button for manual focusing, see p. <?>)

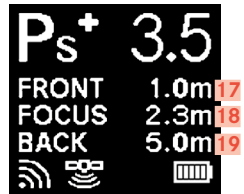

- 1 Time
- 2 Date
- 3 Camera/memory card status
 - **READY:** Ready to take picture
 - **CARD SEARCH:** Memory card check
 - **NO CARD:** No readable memory card found
- 4 Battery capacity (on the right for the battery in the camera; where applicable: on the left for battery in the hand grip) or icon for connected AC adapter S
- 5 WLAN activated
- 6 Memory card in use or if connected via USB 3.0 cable
- 7 ISO setting, alternatively interval shooting is set
- 8 Exposure mode
- 9 Exposure compensation set
- 10 Program shift set
- 11 Aperture
- 12 Shutter speed, as reminder for speeds ≥ 0.5 seconds
- 13 ISO value
- 14 Picture counter; remaining video time in case of video recording
- 15 Battery capacity (on the right for the battery in the camera; where applicable: on the left for battery in the hand grip) or icon for connected AC adapter S
- 16 GPS
 - most recent geolocation max. 6 min ago
 - most recent geolocation max. 24 hrs ago
 - no geolocation data available
- 17 Lower limit of depth of field range
- 18 Set focal length
- 19 Upper limit of depth of field range

Display when setting exposure mode

(appears briefly after pressing and holding the thumbwheel)

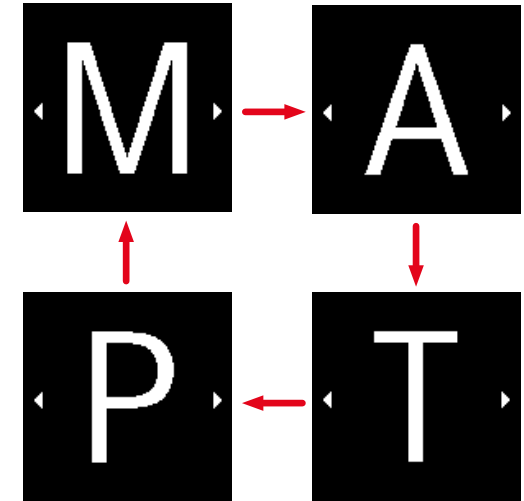

LCD PANEL

WHEN TAKING A PICTURE

INFO DISPLAY

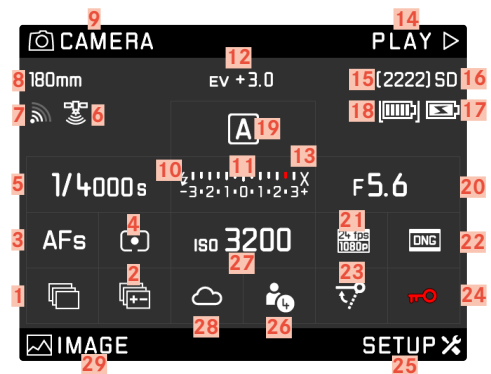

In Live View mode

Standard view

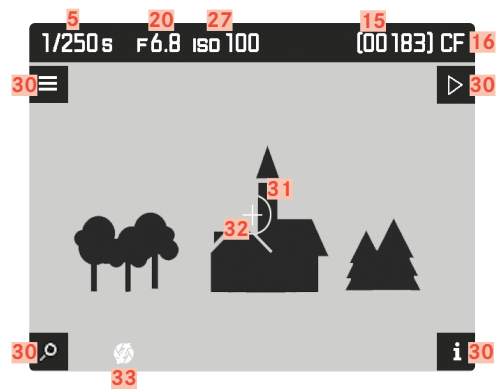

Standard view plus additional displays

A Histogram and clipping displays

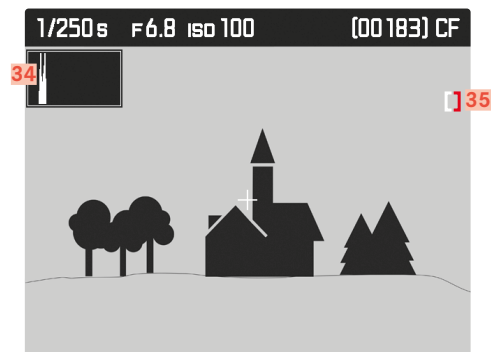

B Focus peaking

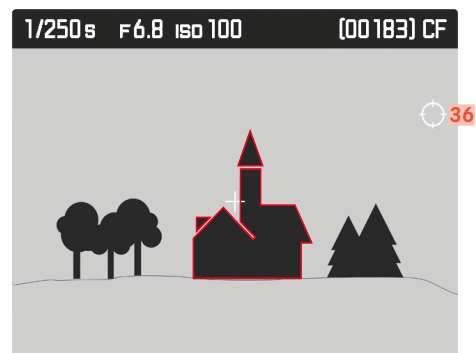

C Grid and level display

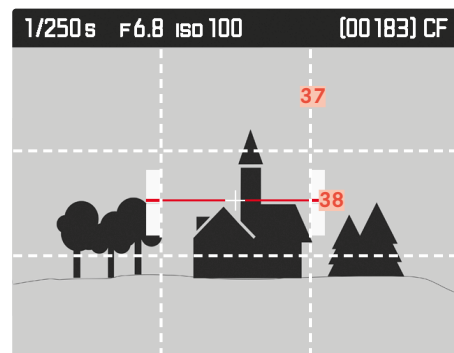



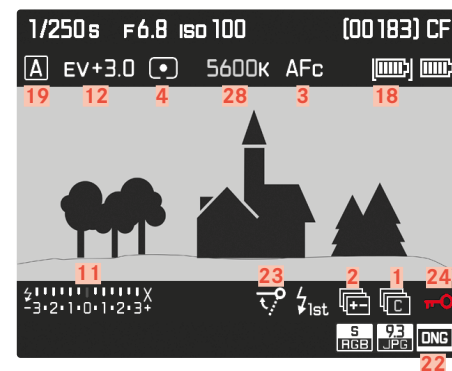



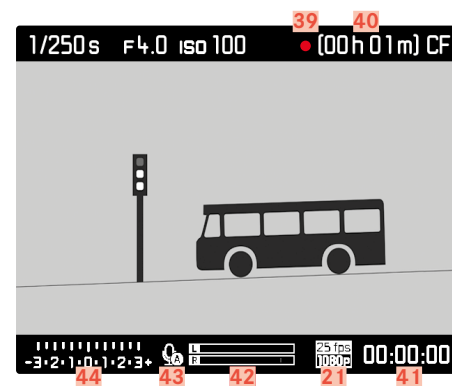





D Additional picture data



Video



- 1** Drive Mode
 -  Single picture
 -  Picture series
 -  Interval shooting
 -  Self-timer mode
- 2** Bracketing
- 3** Focusing mode
- 4** Exposure metering method
- 5** Shutter speed
- 6** GPS status
- 7** WLAN status
- 8** Focal length
- 9** Function of the TL button
- 10** Flash ready indicator
- 11** Light balance
- 12** Exposure compensation
- 13** Flash sync time
- 14** Function of the TR button
- 15** Picture counter
- 16** Memory card(s) used
- 17** Status of the hand grip battery/mains power operation
- 18** Camera battery status
- 19** Exposure mode
- 20** Aperture
- 21** Video resolution/Frame rate
- 22** Photo file format/JPG resolution
- 23** Mirror up mode
- 24** Keylock
- 25** Function of the BR button
- 26** Profile memory slot in use
- 27** ISO sensitivity/setting
- 28** White balance setting
- 29** Function of the BL button
- 30** Button functions
(appear briefly - in all Live View views - after pressing one of the four buttons next to the LCD panel)
 -  Magnification function
 -  Menu control
 -  Playback mode
 -  Change views
- 31** Spot exposure metering field
- 32** Autofocus metering field
- 33** Exposure simulation deactivated
- 34** Histogram
- 35** Clipping icon
- 36** Focus Peaking icon
- 37** Grid lines
- 38** Horizon display
- 39** Indicates recording in progress
- 40** Remaining recording time
- 41** Current recording time
- 42** Sound control display
- 43** Sound recording mode
 -  Automatic control
 -  Manual control
 -  Deactivate sound recording
- 44** Light balance or earphone volume 
Volume off 

IN PLAYBACK MODE

Photo

Standard view



Standard view plus additional displays

A Histogram and clipping displays

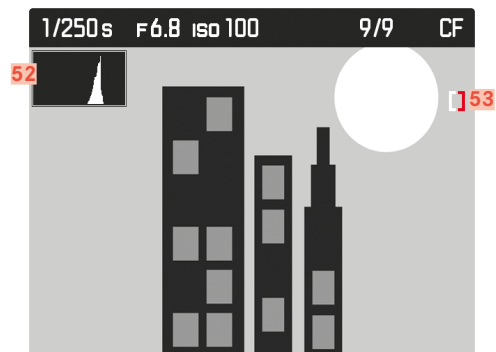

B Focus peaking

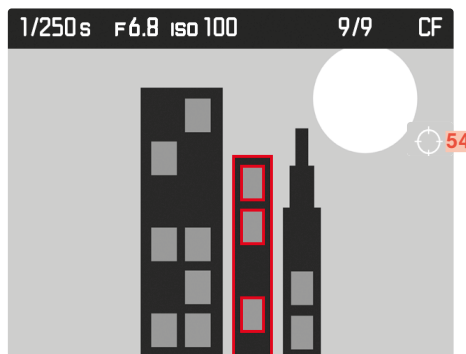

D Additional picture data

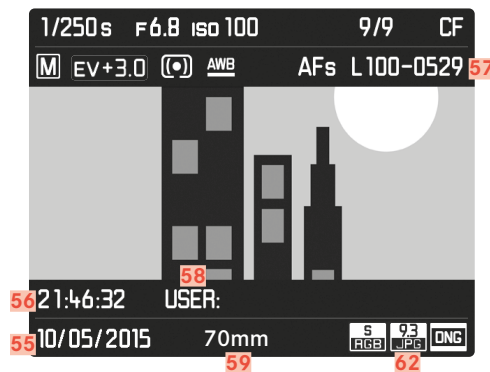

Video

Standard view

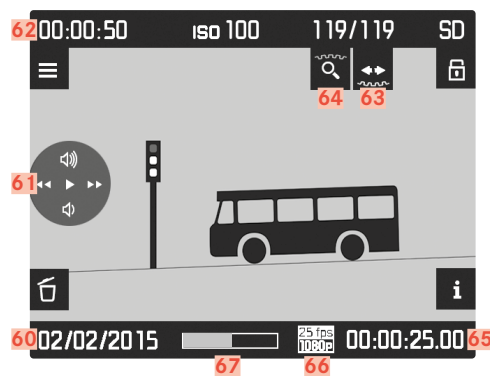

Standard view plus additional displays

A Histogram and clipping displays

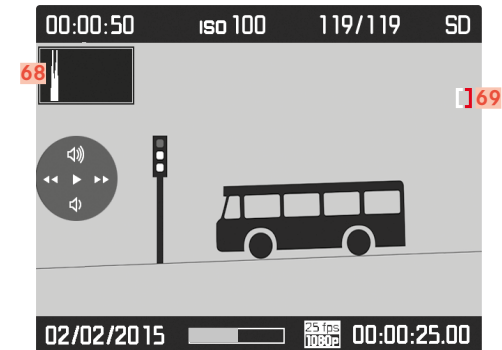



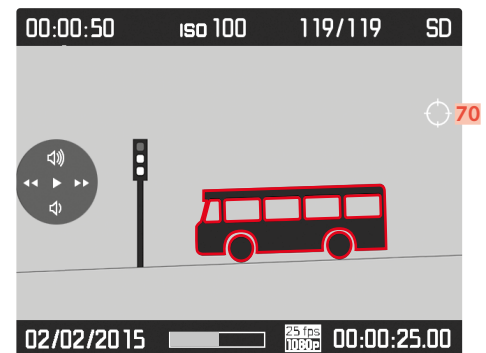



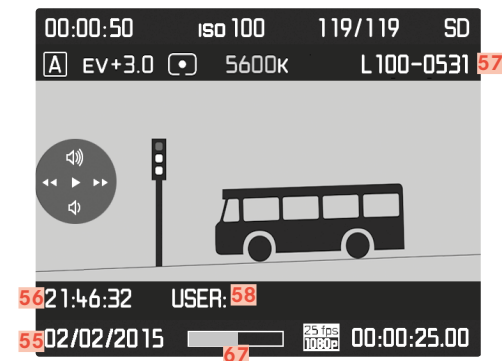



B Focus peaking



C Additional picture data



- 46** Button functions
(appear when review/playback mode is activated in all photo and video views, or after pressing one of the four buttons next to the LCD panel; disappear after approx. 3 s)
-  Delete menu
 -  Menu control
 -  Marking
 -  Change views
- 47** Size and position of cropped section
- 48** Number of the picture displayed / Total number of pictures
- 49** Icon for marked pictures
- 50** Operating hint for browse function
(shutter speed setting dial)
- 51** Operating hint for magnification function (thumbwheel)
- 52** Histogram
- 53** Clipping icon
- 54** Focus Peaking icon
- 55** Picture date
- 56** Recording time
- 57** Image file number
- 58** Profile memory slot
- 59** Focal length used
- 60** Recording date or volume setting ,
volume off 

- 61** Video control icons (for the joystick)
-  Playback (press forward)
 -  Fast forward (press to the right or press and hold)
 -  Rewind (press to the left or press and hold)
 -  Volume: up (press upwards or press and hold)
 -  Volume: down (press downwards or press and hold)
- 62** Total recording time
- 63** Operating hint for browse function (shutter speed setting dial)
- 64** Operating hint for magnification function (thumbwheel)
- 65** Elapsed playback time
- 66** Video resolution/Frame rate
- 67** Status bar for elapsed playback time
- 68** Histogram
- 69** Clipping icon
- 70** Focus Peaking icon

PREPARATION

ATTACHING THE CARRY STRAP

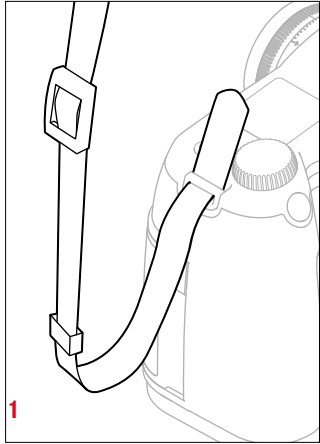

1

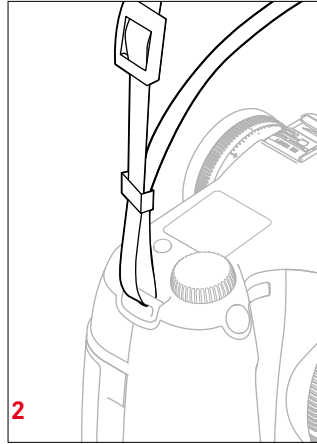

2

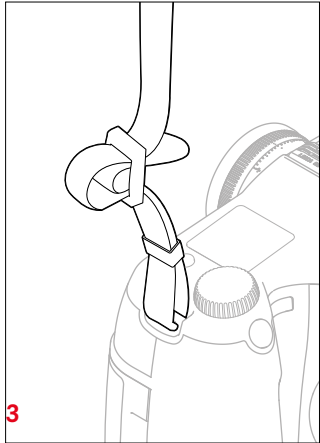

3

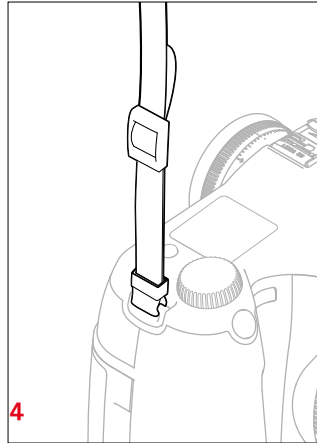

4

Attention

Once you have attached the carry strap, please make sure that the clips are mounted correctly to prevent the camera from falling.

PREPARING THE CHARGER

FOR USE OUTSIDE THE US

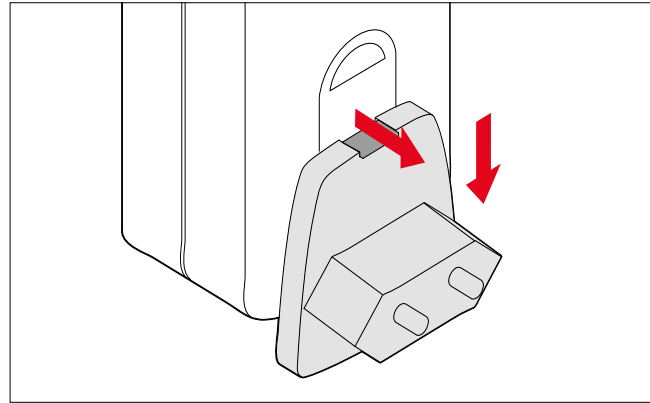

- ▶ Attach the plug suitable for local mains outlets to the charger.
- ▶ Pull the release button upward
- ▶ Slide the plug attachment downward from its stop position
- ▶ Then fully remove the plug
- ▶ Slide the required plug version into the charger until it clicks into place

FOR USE IN THE US

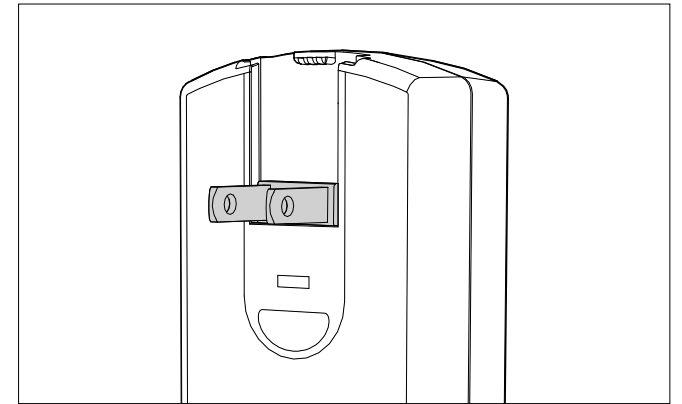

- ▶ Remove the default mains plug installed from the charger
- ▶ Pull the release button upward
- ▶ Slide the plug attachment downward from its stop position
- ▶ Unfold the two pins of the US plug connector from their rest position

Notes

- The charger will automatically adapt to local mains voltage.

CHARGING THE BATTERY

The camera is powered by a lithium-ion battery.

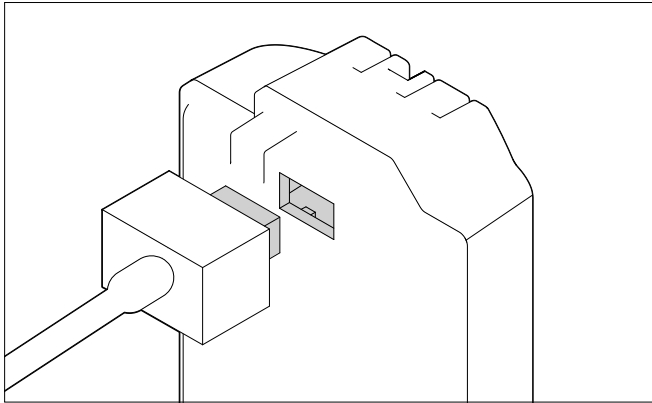

- ▶ Connect the cable plug to the battery jack
- ▶ Plug the mains plug into a wall socket

CHARGE STATUS INDICATORS ON THE CHARGER

The status LED indicates a correct charging process.

Display	Charge status	Charge time (for a completely discharged battery)
CHARGE flashes green	battery is charging	
80% lights up orange	80%	approx. 2 hours
CHARGE continuous green light	100%	approx. 3½ h

Notes

- Disconnect the charger from mains electricity when the charging process is complete. There is no risk of overcharging.

INSERTING/REMOVING THE BATTERY

- ▶ Ensure that the camera is switched OFF (see p. 24)

Insertion

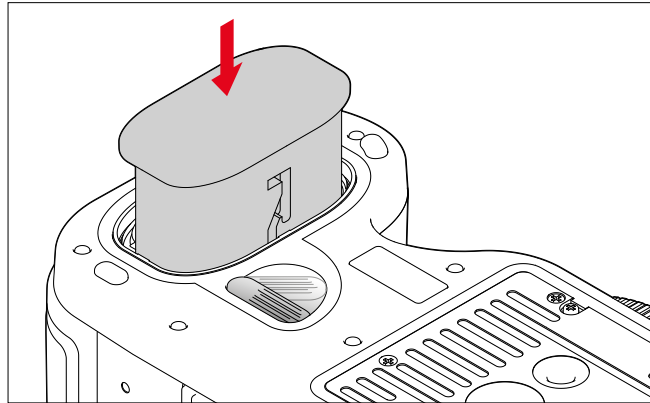

- ▶ Slide the battery as far as it will go into the battery compartment with the contacts facing forward and the guide groove facing the middle of the camera
 - It will automatically engage in that position.

Removal

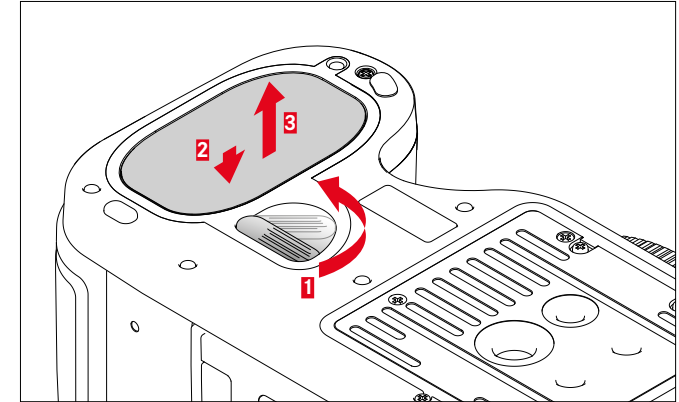

- ▶ Turn the unlock lever clockwise as far as it will go
 - A spring in the battery compartment will then push the battery out by approx. 1 cm.
 - The locking mechanism has a catch to prevent the battery from accidentally falling out, even if the camera is held upright.
- ▶ Push the battery back approx. 1 mm to release the lock
- ▶ Extract the battery from its slot or hold the camera upright so the battery falls into your hand

CHARGE LEVEL DISPLAY ON THE LCD PANEL

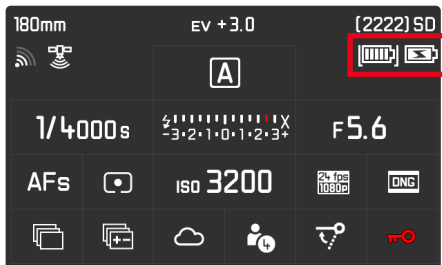

Display	Charge status
	approx. 88 - 100%
	approx. 63 - 87%
	approx. 47 - 62%
	approx. 36 - 46%
	approx. 26 - 35%
	approx. 0 - 25% The battery needs charging or replacing

INSERTION/REMOVAL OF MEMORY CARDS

You can use 2 card types simultaneously in the Leica S3 to store recorded data. It has one card slot for SD/SDHC/SDXC (secure digital) and one for CF (compact flash up to UDMA 7) cards.

Notes

- SD/SDHC/SDXC memory cards are available from various suppliers in various sizes and with differing read/write speeds. Memory cards with high storage capacities and high read/write speeds offer quick storage and rendering.
- Memory cards with a capacity of less than 1GB are not supported. Memory cards with capacities between 1GB and 2GB must be formatted before first use.
- Check the memory card for correct alignment if you are having difficulties inserting it into the camera.

Open the cover **11**

- ▶ Push the cover backward and flip it open on the right

Close the cover **11**

- ▶ Close the cover and push forward until it clicks into place

CF CARDS

- ▶ Make sure that the camera is switched OFF (see p. 24)

Insertion 1

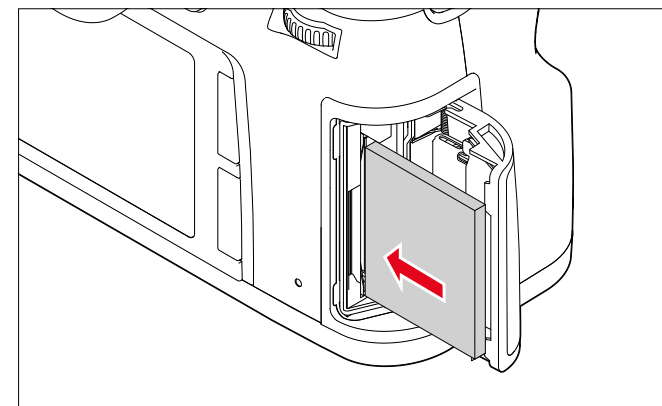

- ▶ Push the memory card as far as it will go into the slot with the contacts facing towards the camera and the front of the card facing the front of the camera
- ▶ Make sure that the ejector pin **21a** is fully pushed in

Important

Do not use excessive force! Excessive force can damage the internal contacts in the memory card slot.

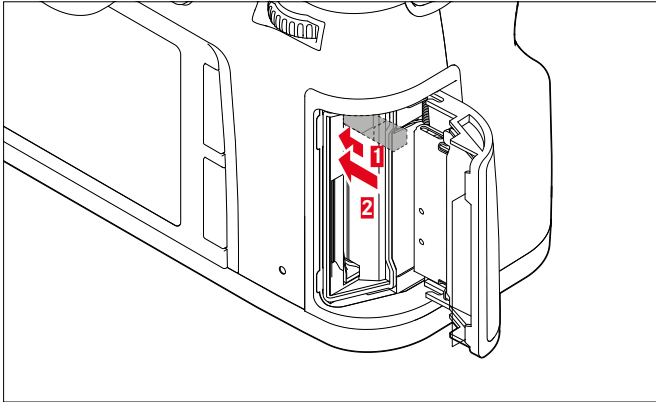
Removal

- ▶ Push in the ejector pin **2.1a**
 - The slider is pushed out slightly.
- ▶ Press the ejector pin again
 - The card is pushed out of the slot a little.
- ▶ Remove the memory card

Important

Check that the cover is closed correctly before you switch on the camera.

SD/SDHC/SDXC CARDS

- ▶ Make sure that the camera is switched OFF (see p. 24)

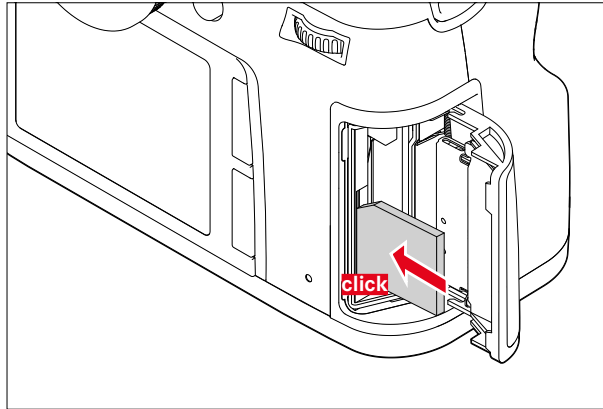
Insertion

- ▶ Memory card - with the contacts facing towards the rear and the beveled corner facing upwards - push the card in fully against the resistance of the spring until it clicks into place

Important

Make sure not to insert a SD/SDHC/SDXC card into the CF card slot as it may be impossible to remove.

- Karte schiebt sich etwas heraus.

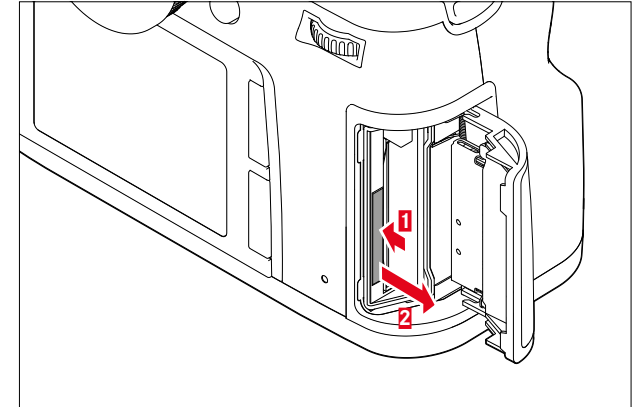
Removal

- ▶ Push the memory card deeper into the slot
- ▶ Remove the memory card

Important

Check that the cover is closed correctly before you switch on the camera.

CHANGING THE FOCUSING SCREEN

The focusing screen on the Leica S3 can be replaced. The camera is supplied with a fully matte screen as standard.

Other focusing screens are supplied individually in a container with tweezers and a dusting brush.

Replacing the screen

- ▶ Detaching the lens

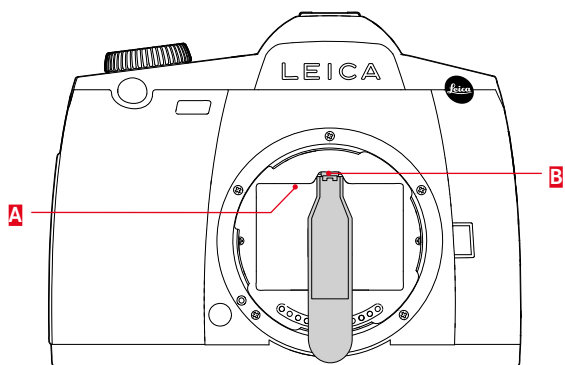

- ▶ Release the screen frame **A** from its locked position by pressing tab **B** with the blunt end of the tweezers
 - The frame including the focusing screen flips open.

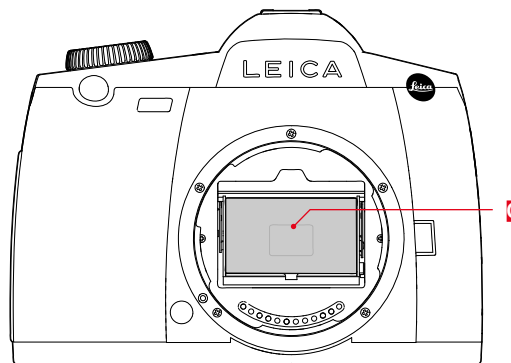

- ▶ Use the tweezers to grab the small stay on the focusing screen **C**, tilt slightly upwards and remove
- ▶ Temporarily place the removed screen in the side compartment of the container

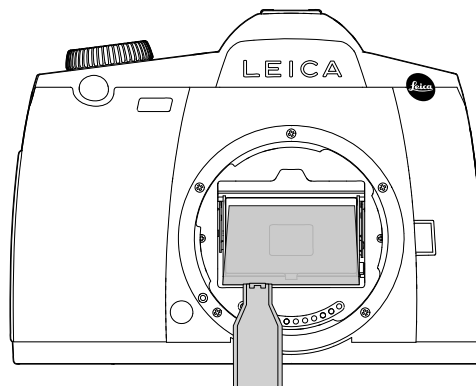

- ▶ Grab the stay on the screen with the tweezers and place it into the frame.
- ▶ Use the blunt end of the tweezers to push the frame upwards until it clicks into place.

Important

Proceed exactly as described when changing the focusing screen. Be sure to protect the sensitive surfaces of the focusing screens against scratches.

COMPATIBLE LENSES

All lenses and accessories with a Leica S bayonet can be attached to the Leica S3.

LEICA S LENSES

Leica S lenses are easily recognized by their characteristic outer features:

- The focus ring function differs depending on which sharpness mode is set.
- In manual mode (MF), the focus is set as usual by turning the ring. In this case, it is mechanically coupled to the optical structure as standard.
- In auto focus mode (AFs/AFc), it is initially decoupled to ensure that holding the lens on the ring will not prevent motorized adjustment. You can "override" the automatic setting at any time and can also set the focus manually while in AF mode. The ring will then be coupled to the lens when it is moved.
- The internal distance scale can be read off a window.
- The lenses do not come with an aperture setting ring. The aperture setting is changed via the setting wheel on the camera housing.

Notes

- Some Leica S lenses are also available with an integrated central shutter.
- Leica Camera AG manufactures its products in compliance with highest quality standards. Extensive calibration and test steps are required during the production process to ensure perfect functioning. That is why the camera and the lenses are connected to various test devices multiple times. These important work steps may leave slight shiny patches on the stainless steel bayonet rings. That is not a quality defect; it simply indicates that your Leica S3 and your Leica S lenses were thoroughly tested.
- The adapters available from Leica as accessories and which allow the use of third-party medium-format lenses, are attached and removed exactly the same way. Please read the relevant manuals for more details on the adapters.

ATTACHING/DETACHING LENSES

Attaching

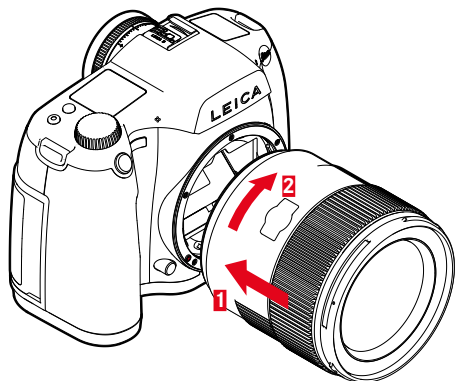

- ▶ Make sure that the camera is switched OFF
- ▶ Hold the lens on the fixed ring
- ▶ Position the alignment button on the lens opposite the release button on the camera housing
- ▶ Attach the lens in this position
- ▶ Turn the lens clockwise until you hear and feel it click into place

Removal

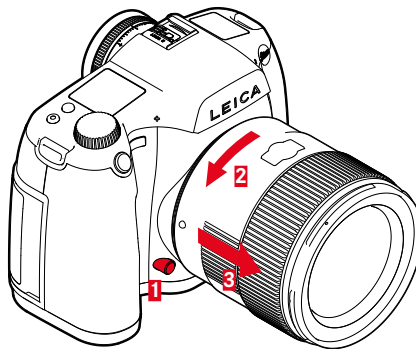

- ▶ Make sure that the camera is switched OFF
- ▶ Hold the lens on the fixed ring
- ▶ Press and hold the release button on the camera housing
- ▶ Turn the lens counter-clockwise until the alignment button is opposite the release button
- ▶ Remove the lens

DIOPTER SETTINGS

The viewfinder has a diopter setting function with a range between +1 and -3 diopter to allow glasses wearers the use of the camera without eyeglasses (diopter adjustment).

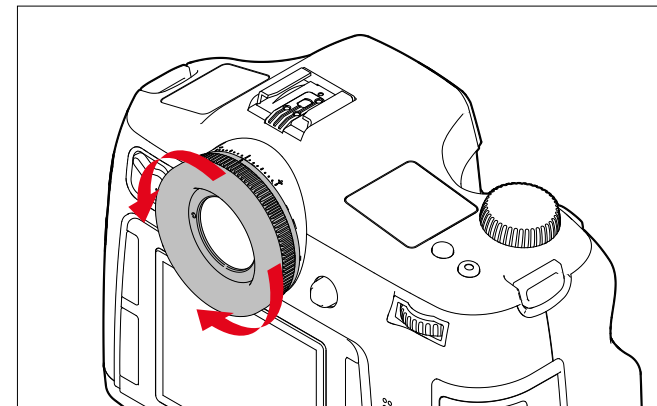

- ▶ Look through the viewfinder
- ▶ Turn the diopter setting wheel until you see the image in the viewfinder and the displays in perfect focus

Note

We recommend attaching the eyepiece cover when not utilizing the viewfinder, e.g. when working with a tripod. This prevents the exposure metering from being affected. The cover can be attached to the carry strap.

CAMERA OPERATION

OPERATING ELEMENTS

MAIN SWITCH

The main switch switches the camera on and off.

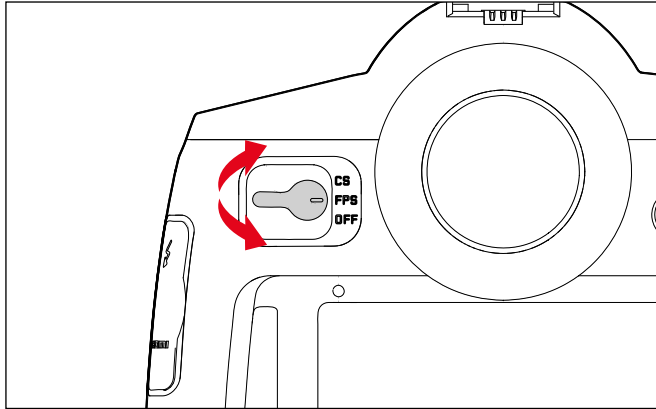

OFF	Camera is OFF	
FPS (Focal Plane Shutter)	Camera is ON	<p>The focal plane shutter in the camera housing is operational</p> <ul style="list-style-type: none"> - The shutter speed is controlled via the focal plane shutter in the camera. All speed setting can be selected.
CS (Central Shutter)	Camera is ON	<p>The central shutter in a (relevantly equipped) lens is operational</p> <ul style="list-style-type: none"> - The shutter speed is controlled via the central shutter in the lens. Shutter speeds between $8\text{-}\frac{1}{1000}$ s can be selected.

Notes

- The camera will utilize the focal plane shutter if a lens without central shutter is attached and/or slower shutter speeds than 8 s or faster speeds than $\frac{1}{1000}$ s are set – even if **CS** is selected.
- When the camera is switched on, the LED at the bottom right, next to the LCD panel will light up until the camera is ready (2 s) and the displays appear in the viewfinder and the top display.
- The camera will switch off automatically if automatic shutdown is enabled via the menu controls, even if the main switch is not set to **OFF** (see p. 30).
- Switching off the camera will cancel running functions like bracketing and self-timer mode; the functions will simultaneously be disabled in their relevant menus.

SHUTTER BUTTON

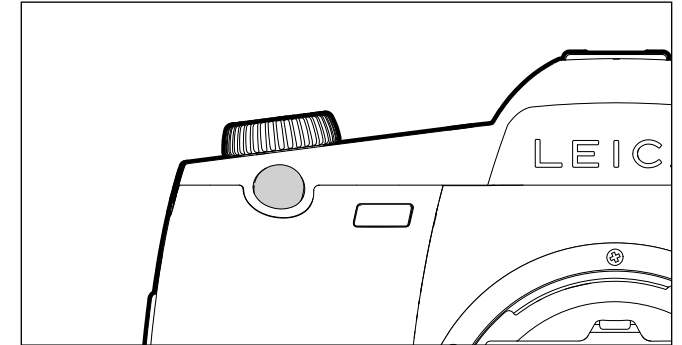

The shutter button works in two stages.

1. **Tap** (= Press the shutter button to the 1st pressure point)
 - activates the camera electronics and rangefinder display
 - saves the metered exposure value in aperture priority mode, i.e. the shutter speed calculated by the camera
 - restarts a self-timer delay in progress
 - reverts the camera to picture mode:
 - if playback mode is set
 - if menu control is active
 - if the camera is in Standby mode
 - saves the focus setting for **AFS**.
2. **Press down fully**
 - to take the picture
 - The data is then transferred to the memory card.
 - starts a preselected self-timer delay

Notes

- Press down the shutter button in a smooth motion until you hear the click of the shutter to prevent camera shake.
- The shutter button remains locked
 - if the memory card inserted and the internal buffer memory are (temporarily) full.
 - if the battery has exceeded its performance limits (capacity, temperature, age).
 - if the memory card is write-protected or damaged.
 - if image numbering on the memory card has reached its limit.
 - if the camera prompts for language, date and time settings at first use or after a reset.
 - if the sensor is too hot.
- When the shutter button is released, camera electronics and viewfinder displays remain active for the time set in the main menu for **Auto Power Saving**.

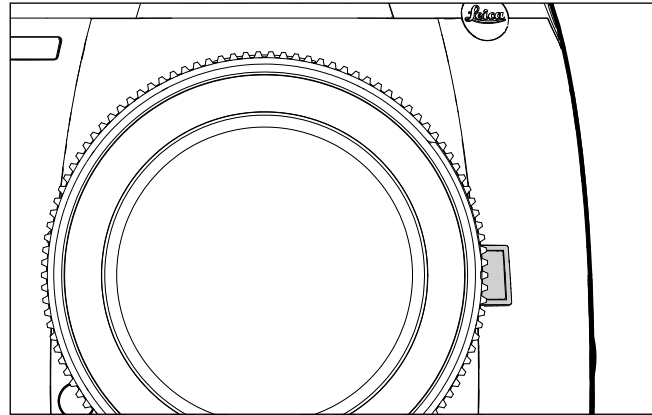
DEPTH-OF-FIELD PREVIEW BUTTON

The function of the Depth-of-field preview button varies depending on the mode selected:

Operating mode		Function
Picture mode	Using the viewfinder	Press and hold to take a picture, or press for quick access to the set menu function
	Using the LCD panel (Live View)	Press (repeatedly) to activate/deactivate exposure simulation
Video recording mode		Press and hold to access the settings for the sound recording level and headphone volume; this function is independent of the settings for normal photo mode and cannot be changed

MENU CONTROL

Most modes and settings for the Leica S3 are selected via menu control. The menu items are organized in function groups for quick navigation.

CONTROL ELEMENTS

The following elements are used for menu control.

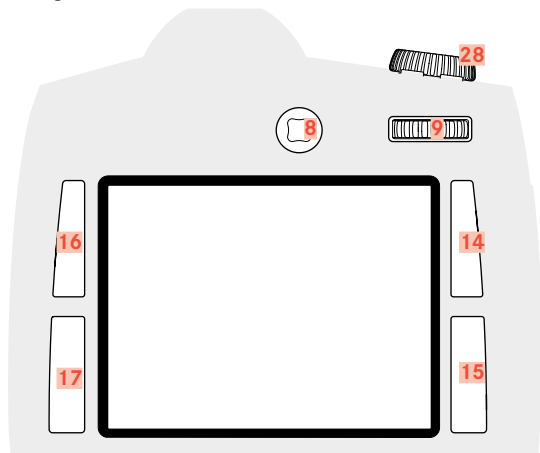

- 8** Joystick
- 9** Thumbwheel
- 14** Playback/Menu control/Function button (Top **R**ight **b**utton)
- 15** Menu control/Function button (Bottom **R**ight **b**utton)
- 16** Menu control/Function button (Top **L**eft **b**utton)
- 17** Menu control/Function button (Bottom **L**eft **b**utton)
- 28** Shutter speed setting wheel/Function wheel

STRUCTURE OF THE MENU SCREEN

FUNCTION GROUPS

The Leica S3 menu is split into 3 function groups (the list is available on p. 64):

- **CAMERA** function group
- **IMAGE** function group
- **SETUP** function group

Other menu items with relevant submenus or setting options are available in each function group.

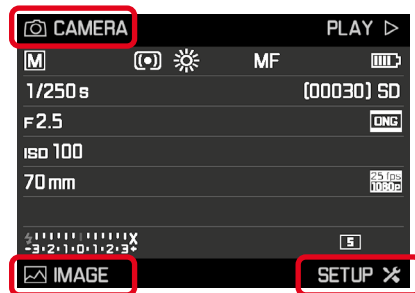

Notes

- All four of these buttons are so-called “soft keys”. Outside of menu control, e.g. in Live View and Video mode (and when viewing pictures on the LCD panel), they each have other functions. These functions are then relevantly indicated on screen.
- **INFO** next to the top right button indicates that you can call up the picture data display from within menu control by briefly pressing this button.

MAIN MENU

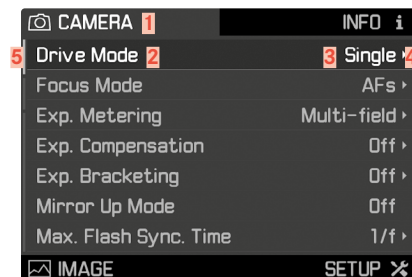

- 1** Function group
- 2** Menu item name
- 3** Menu item setting
- 4** Submenu reference
- 5** Scrollbar: current position in the menu list

SUBMENU

The currently set function option or currently set value is displayed in the line on the right.

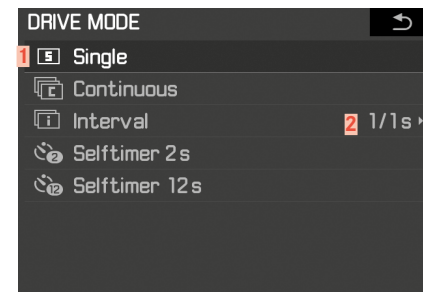

- 1** Current menu item
- 2** Submenu item
- 3** References to other submenus

Note

In some cases, an additional scale will be available, where values can be set or function options can be selected.

SHOW MENU PAGES

SHOW FUNCTION GROUP (ACCESS TO MENU CONTROL)

- **SETUP** function group
 - ▶ Press the BR button **15**
- **CAMERA** function group
 - ▶ Press the TL button **16**
- **IMAGE** function group
 - ▶ Press the BL button **17**





In Picture mode (Viewfinder)

- ▶ Press the TL/BL/BR button **2x** (≤ 1 s)
 - The info display appears (picture data display) when the button is pressed the first time. Pressing the button a second time will display the main menu of the relevant function group.

In Picture mode (Live View)

- ▶ Press the TL button **2x**

In Playback/Review mode

- ▶ Press the TL/BL/BR button **1x**
 - The shortcut display appears:
 - top left:  (Menu)
 - bottom left:  (delete)
 - top right:  (mark)
 - bottom right:  (Recording data display)

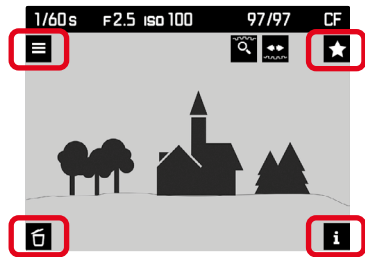

- ▶ Press the TL button **1x**

SHOW SUBMENU

- ▶ Press thumbwheel/joystick

MENU NAVIGATION

NAVIGATING WITHIN THE MENUS

All menu item settings can be selected via the thumbwheel or the joystick.

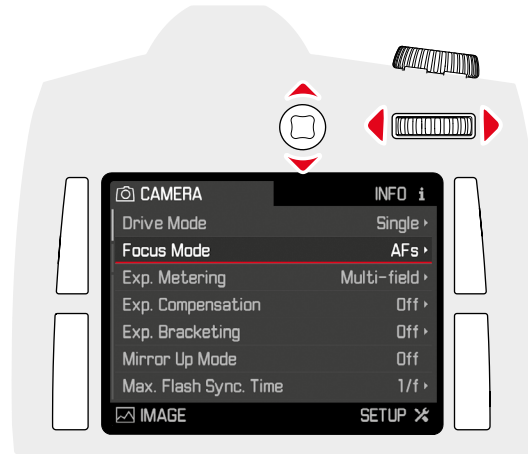

Line by line navigation

- ▶ Turn the thumbwheel
(to the right = down, to the left = up)
- or
- ▶ Move the joystick up/down

Notes

The menu items in the three function groups are arranged in an endless loop. All menu items can therefore be reached in either direction.

Navigating within a line or on a scale

- ▶ Turn the thumbwheel
- or
- ▶ Move the joystick left/right

CONFIRM SELECTION

- ▶ Press thumbwheel/joystick
 - The screen image changes back to the active menu item. The set function variant is shown on the right in the relevant menu line.

Note

No confirmation is needed for the selection of **ON** or **OFF**. It is saved automatically.

GO BACK ONE STEP (LEAVE SUBMENU)

Returning to the menu without applying the changes made in the submenu:

- ▶ Press the TR button 

EXITING THE MENU

You can exit menus and submenus at any time with/without applying the settings made.

Go to Picture mode

- ▶ Press the shutter/video/Live View button

Go to Playback mode

- ▶ Press the TR button

KEYPAD SUBMENU OPERATION

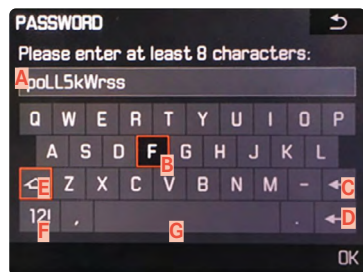

- A** Entry line
- B** Keyboard
- C** "Delete" button (deletes the last character entered)
- D** Press "Confirm" (to apply individual values and to complete settings)
- E** Shift (toggles upper/lower case)
- F** Changing the character type
- G** Space

To get to the character you want:

- ▶ Move the joystick right/left/up/down
- or
- ▶ Turn the thumbwheel

To toggle between upper and lower case letters:

- ▶ use the joystick to select the Shift button **E**
- ▶ Press thumbwheel/joystick

To change the character type (letters/numerals):

- ▶ use the joystick to select the **F** button
- ▶ Press thumbwheel/joystick

To enter the selected character:

- ▶ Press thumbwheel/joystick

To get to the previous menu level without applying changes:

- ▶ Press the TR button (↶)

To save:

- ▶ Press the BR button (OK)

OPERATING THE NUMBER PAD SUBMENU

**To get to the number you want:**

- ▶ Turn the thumbwheel
- or
- ▶ Move the joystick to the relevant direction

To apply a number:

- ▶ Press thumbwheel/joystick

To get to the previous menu level without applying changes:

- ▶ Press the TR button (↶)

To save:

- ▶ Press the BR button (OK)

QUICK ACCESS (SHORT CUT)

For extra quick operation, you can press one of the four buttons – and the Preview button in regular Picture mode – to access up to 5 of your most frequently used menu functions directly. Select the (menu) function you want to access via one of these buttons.

The buttons have the following default quick access assignments ex works:

TL button 16	ISO
BL button 17	Exp. Metering
TR button 14	Focus Mode
BR button 15	Exp. Compensation
Depth-of-field preview button 4 in <u>Picture mode</u>	Stopping down
in <u>Live View mode</u>	Exposure simulation ON/OFF*
in <u>Video playback mode</u>	Access to the settings for the sound recording level and headphone volume*

*cannot be changed

MANAGE QUICK ACCESS

- ▶ Select **SETUP**
- ▶ Select **Customize Controls** in the main menu
- ▶ Select **Short Cuts** in the submenu
 - Another submenu appears. All other menu items are inactive if the submenu set to **Default**.

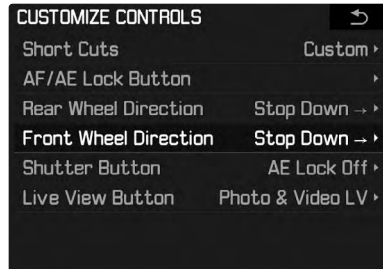

- ▶ Select **Custom** in the submenu

- If the factory settings for the button assignments should be used
 - ▶ Select **Default**
- or
- If you want to deactivate the assigned function
 - ▶ Select **Off**
- If you want to assign another menu item to the button
 - ▶ Press the button of your choice
 - A list of available menu functions appears.

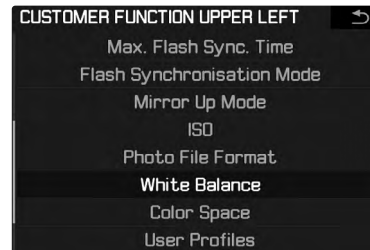
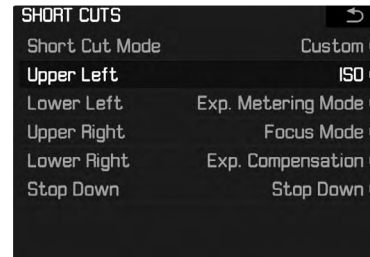

- ▶ Select the menu function you want to assign
- or
- ▶ Select **Off** if you don't want to assign a quick access function to this button.

ACCESSING A QUICK ACCESS MENU ITEM

The menu options assigned to the function button for quick access can be accessed at any time directly to make further settings and execute the assigned function.

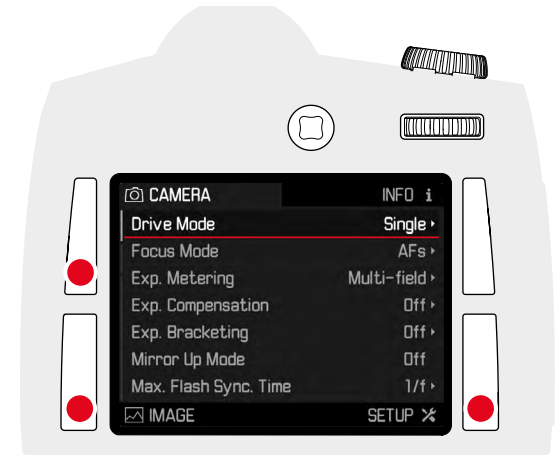

- ▶ Press and hold the function button of your choice (≥ 1 s)

Note

The Depth-of-field preview button has other functions assigned in Live View in photo (taking pictures) and in video (recording) mode. An assigned quick access function may therefore be inaccessible in these modes.

BASIC CAMERA SETTINGS

MENU LANGUAGE

Factory setting: English

Available menu languages: German, French, Italian, Spanish, Portuguese, Russian, Japanese, Korean and Traditional or Simplified Chinese

- ▶ Select **SETUP**
- ▶ Select **Language** in the main menu
- ▶ Select your language
 - Aside from a few exceptions (button names, short names), the language will be changed for all information.

DATE/TIME

DATE

You can choose one of 3 options.

- ▶ Select **SETUP**
- ▶ Select **Date & Time** in the main menu
- ▶ Select **Date Setting** in the submenu
- ▶ Select the desired date format
(**Day/Month/Year**, **Month/Day/Year**, **Year/Month/Day**)
- ▶ Set the date

TIME

- ▶ Select **SETUP**
- ▶ Select **Date & Time** in the main menu
- ▶ Select **Time Setting** in the submenu
- ▶ Select the desired display format
(**12 Hours**, **24 Hours**)
- ▶ Set the time
(Select **am** or **pm** for the 12-hour format)

AUTOMATIC TIME VIA GPS

- ▶ Select **SETUP**
- ▶ Select **GPS** in the main menu
- ▶ Select **On**
- ▶ Select **Date & Time** in the main menu
- ▶ Select **Auto GPS Time** in the submenu
- ▶ Select **On**

TIME ZONE

- ▶ Select **SETUP**
- ▶ Select **GPS** in the main menu
- ▶ Select **Off**
- ▶ Select **Date & Time** in the main menu
- ▶ Select **Time Zone** in the submenu
- ▶ Select your time zone/current location
 - The Greenwich Mean Time offset is shown on the left of the line
 - Major cities in the relevant time zones are shown on the right

DAYLIGHT SAVING TIME

- ▶ Select **SETUP**
- ▶ Select **GPS** in the main menu
- ▶ Select **Off**
- ▶ Select **Date & Time** in the main menu
- ▶ Select **Daylight Saving Time** in the submenu
- ▶ Select **On**

Notes

- **Auto GPS Time** is available only if the GPS function is set to **ON**. **Time Zone** and **Daylight Saving Time** are available only if the GPS function is set to **OFF**.

AUTO POWER SAVING (STANDBY MODE)

The camera will switch to the power-saving standby mode after a preset time to extend battery life if this function is activated.

- ▶ Select **SETUP**
- ▶ Select **Auto Power Saving** in the main menu
- ▶ Select the desired setting
(**2 Min**, **5 Min**, **10 Min**, **Off**)

Note

The camera can be woken from standby mode at any time by pressing the shutter button or by switching the main switch off and on again.

ACOUSTIC SIGNALS

The Leica S3 allows you to decide whether messages or Autofocus mode should be confirmed with acoustic signals or whether camera operation should be more or less silent. The signal is a beep that can be activated separately for Autofocus mode to indicate a setting and to notify of a message or warning.

In factory settings, the acoustic signals are switched off.

- ▶ Select **SETUP**
- ▶ Select **Acoustic Signals** in the main menu
- ▶ Select **AF Confirmation/Warnings** in the submenu
- ▶ Select **On** or **Off**.

Notes

- An acoustic signal sounds when **AF Confirmation** is set, when the sharpness is set correctly (manually or automatically), i.e. at the same time that the relevant display lights up in the viewfinder.
- A signal sounds for **Warnings** in conjunction with all messages and warnings displayed on screen, and when the self-timer countdown completes.
- In two cases, an acoustic warning signal will sound even if you have set the acoustic signal to **Off**:
 - If the cover over the memory card slots is opened during data transfer
 - Just before the shutter closes at the end of the sensor cleaning process

VOLUME

You can choose one of two volume settings.

- ▶ Select **SETUP**
- ▶ Select **Acoustic Signals** in the main menu
- ▶ Select **Volume** in the submenu
- ▶ Select a volume setting
(**Low**, **High**)

LCD PANEL/TOP DISPLAY/VIEWFINDER SETTINGS

The Leica S3 comes equipped with two displays:

- a black-and-white liquid-crystal display (LCD)
- a large 3" LCD color screen protected by a hard and therefore highly scratch-resistant glass cover.

The information shown in the top display includes some basic information about the status of the memory card and battery, as well as about exposure control. The LCD panel renders the entire image field and the currently selected data and information (see "Displays", p. 12).

BRIGHTNESS

Screen brightness is controlled automatically, depending on ambient brightness. A sensor **20** above the LCD panel controls this brightness. You can additionally control its basic brightness in line with the situation at hand or your personal preferences.

- ▶ Select **SETUP**
- ▶ Select **Display Brightness** in the main menu
- ▶ Select the automatic setting (**Auto**) or the desired level

INFORMATION DISPLAYS

You can display picture data on screen for information purposes. (see p. 12 for more information)

In Picture mode (Viewfinder)

- ▶ Press the TL/BL/BR button **1x**

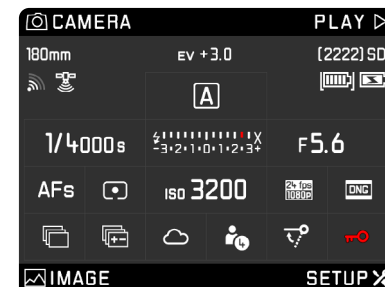

In Picture mode (Live View)

- ▶ Press the BR button



There are various options for displaying information in Live View mode (see p. 12).

To change the display format,

- ▶ Press the BR button until the display format of your choice appears

In Playback/Review mode

- ▶ Press the TR button

BASIC PICTURE SETTINGS

PHOTO

FILE FORMAT

You can choose between the JPG format or the standardized raw data format DNG (= digital negative). These can be used individually or simultaneously.

- ▶ Select **IMAGE**
- ▶ Select **Photo File Format** in the main menu
- ▶ Select a value
(**DNG**, **DNG + JPG**, **JPG**)

Notes

- The standardized DNG (Digital Negative) format is generally used for the storage of raw data.
- The resolution setting for the JPG format is used (see next section), i.e. the files may have differing resolutions if picture data is saved in DNG and in JPG format simultaneously.
- The remaining number of pictures shown in the LCD panel will not necessarily change after every picture taken. A counter change depends on the subject; very fine image structures result in higher data quantities, while homogeneous surfaces mean less data.

JPG COLOR SPACE

The Leica S3 allows you to choose one of three color spaces: **sRGB**, **AdobeRGB** or **ECI RGB 2.0**.

- ▶ Select **IMAGE**
- ▶ Select **Photo Settings** in the main menu
- ▶ Select **JPG Color Space** in the submenu
- ▶ Select a color space

JPG RESOLUTION

If the JPG format is selected, then pictures can be taken with 3 different image resolution (number of pixels). 64 MP, 24 MP and 4 MP (MP = megapixel). You can therefore adjust your settings to the intended use and available memory card capacity.

- ▶ Select **IMAGE**
- ▶ Select **JPG Resolution** in the main menu
- ▶ Select the desired resolution
(**64MP**, **16MP**, **4MP**)

Note

The DNG format always uses the highest resolution (64 MP), no matter what JPG setting is selected.

IMAGE PROPERTIES

One of the many advantages of digital photography is that it is very easy to change key image properties.

You can manipulate contrast, sharpness and color saturation before the picture is taken.

Note

The functions and settings described in this section apply for pictures taken in **JPG** format only.

CONTRAST

The contrast setting, i.e. the difference between light and dark image sections, determines whether an image comes across as "flat" or "brilliant". Increasing or decreasing this difference impacts on contrast, meaning that some image sections are rendered with more or less light.

SHARPNESS

The impression of sharpness in a picture is largely determined by edge sharpness, i.e. by how slight the transition area between light and dark is at edges in the picture. Expanding or reducing these areas will therefore change the impression of sharpness.

COLOR SATURATION

The saturation factor in color images determines, whether colors in the picture appear "pale" and pastel-like or "bright" and colorful. While you can't do anything about weather conditions (clear/misty), you can change the way an image is rendered.

- ▶ Select **IMAGE**
- ▶ Select **Photo Settings** in the main menu
- ▶ Select **JPG Contrast**/**JPG Sharpness**/**JPG Saturation** in the submenu
- ▶ Select the desired color
(**Low**, **Default**, **High**)

MONOCHROME RECORDINGS

You can choose to save your images in color or monochrome, provided you take the pictures (also) in JPG format.

- ▶ Select **IMAGE**
- ▶ Select **Photo Settings** in the main menu
- ▶ Select **JPG Monochrome**

MEMORY CARD MANAGEMENT

Your Leica S3 allows you to choose if you want to store all picture data to one memory card until its capacity limit is reached and then start storing data on the other, or to store data on both cards simultaneously, provided you have two memory cards inserted.

If you want to store all picture data on the SD/SDHC/SDXC card first, and only start storing on the CF card, once its capacity limit is reached:

- ▶ Select **SETUP**
- ▶ Select **Storage Backup [CF+SD]** in the main menu
- ▶ Select **Off**

Note

As soon as the camera is connected to a computer, it will transfer and store the picture data to the specified folder on the computer.

If you want to store the picture data on both cards simultaneously:

- ▶ Select **SETUP**
- ▶ Select **Storage Backup [CF+SD]** in the main menu
- ▶ Select **On**

Notes

- If only one card is used (irrespective of which), the picture data will be stored on that card.
- As soon as the camera is connected to a computer, it will store the picture data on a card and also transfer and store the data to specified folder on the computer.

PICTURE MODE (FOTO)

LIVE VIEW MODE

In Live View mode, you can view the image object on the LCD panel while the picture is taken. The image is shown exactly as it is rendered by the attached lens.

Live View mode ON/OFF

- ▶ Press the LV button **29**

Customizing the LV button

- ▶ Select **SETUP**
- ▶ Select **Customize Controls**
- ▶ Select **Live View Button** in the submenu
- ▶ Select the desired function
(**Photo LV**, **Video LV**, **Photo & Video LV**)

Pressing the button displays the following functions in sequence (in an endless loop):

- **Photo LV**: Photo Live View mode ON/OFF
- **Video LV**: Video mode (without starting to record) ON/OFF
- **Photo & Video LV**: in sequence: Photo Live View/Video/regular photography mode.

Notes

- Live View mode is based on the image captured by the sensor. The camera must control the shutter. Shutter control is audible and may result in a slight delay in shutter release.
- The camera will warm up when Live View mode is used for an extended period of time. Power consumption will simultaneously increase.
- Alternating current causes brightness fluctuations invisible to the human eye in many light sources. This may result in a flickering of the Live View screen image due to the sensitivity and scan rate of the image sensors. Picture quality will not be impacted. The effect can be avoided by selecting a slower shutter speed.

FOCUSING

FOCUS METERING METHODS

Your Leica S3 offers you the choice between manual or automatic focusing in conjunction with any S lens. The autofocus system determines the distance to the subject elements in the middle of the image field. The area is marked with cross hairs on the focusing screen or in Live View mode on the LCD panel.

A display in the viewfinder offers information about the current setting, whatever mode is selected (see p. 12 for more information)

Note

The metering system operates passively on the basis of contrasts, i.e. the light/dark differences in the image subject. It is therefore dependent on some brightness and contrast in the subject.

AUTOMATIC FOCUSING (AUTOFOCUS)

Two Autofocus modes are available. The setup process of both is initiated by tapping the shutter button.

- ▶ Select **CAMERA**
- ▶ Select **Focus Mode** in the main menu
- ▶ Select a type
(**AFs**, **AFc**)

AFs (single)

Suitable for objects with little or no movement. Focusing is done only once and the setting remains as long as the shutter button is held at the pressure point. That also applies if the AF metering field is pointed at another object.

Note

An AF setting can be stored via the shutter button or the joystick.

AFc (continuous)

Suitable for objects in motion. As long as the shutter button is held at the 1st pressure point, focusing is continuously adjusted to the object in the AF metering field.

- ▶ Select **Focusing** in the main menu
- ▶ Select **Focus Mode** in the submenu
- ▶ Select the desired setting

Notes

- You can manually change the focus setting in autofocus mode at any time by turning the focus setting ring.
- In Live View mode, the color of the metering cross hairs on the LCD panel will change from red to green once the focus is set correctly.
- **AFc** is not available in Live View mode.

MANUAL FOCUSING

Turn the Focus ring on the lens until your subject or a key feature of the subject is fully in focus on the focusing screen in the viewfinder or on the LCD panel in e.g. Live View mode.

- ▶ Select **CAMERA**
- ▶ Select **Focus Mode** in the main menu
- ▶ Select **MF**

You can have your settings and the limits of the current depth of field range shown in the top display.

You can select the unit of measure for the display or deactivate the display altogether.

- ▶ Select **SETUP**
- ▶ Select **Capture Assistants** in the main menu
- ▶ Select **Distance unit. [m/ft.]** in the submenu
- ▶ Select a unit of measure - **m** (meters) or **ft** (feet/inches) or deactivate the display - **OFF**.
 - When the function is activated, the distance values for the set distance (**FOCUS**) and the front (**FRONT**) and rear (**BACK**) limits of the depth of the field are displayed when the shutter button is pressed to the 1st pressure point.

Notes

- You can activate the Autofocus mode at any time via the joystick while using the manual focus option.
- The Leica S3 comes equipped with a focusing screen as standard, with allows setting a focus on subject elements anywhere in the image field. It is suitable for most photographic fields of application and subjects. It is particularly useful when working with longer focal lengths and for macro photography. Other focusing screens are available as optional accessories, which offer excellent setting options depending on the field of application and which are easy to replace.

ASSIST FUNCTIONS FOR MANUAL FOCUSING IN LIVE VIEW MODE

Your camera offers two useful assist functions to facilitate and improve setting accuracy:

- The magnification of an (initially) central cropped section of the screen image (Zooming).
- Marking of screen image sections where subject elements are in clear focus (Focus Peaking)

Both assist functions can be used simultaneously. Both assist functions are part of the factory settings and therefore activated as standard. You can optionally use only the magnification function or only Focus Peaking – or you can deactivate both.

ENLARGEMENT

Enlarged display of a central section:

The larger details of the image subject appear on the screen, the better you can assess their sharpness.

Select cropped sections at different levels of magnification:

- ▶ Press the BL button repeatedly
 - The view will appear as follows in sequence
 - 50% magnification
 - 100% magnification
 - back to original size
 - There will be no button display in magnification view; a frame containing a rectangle will appear at the bottom left, which indicates the position of the cropped section in the image.

Moving the cropped section:

- ▶ Move the joystick to the relevant direction

Notes

- The grid lines are not displayed in magnification view.
- The most recently selected view will appear after the camera is switched off and on again. The most recently selected displays will appear when Live View mode is deactivated and activated again, but not the enlarged view.

You can call up an enlarged cropped section in Live View to help with picture settings. When this function is activated, a 100% magnification of the central image section is initially displayed each time the focus setting ring is turned. Use the joystick to move the magnified section to another part of the image.

- ▶ Select **SETUP**
- ▶ Select **Capture Assistants** in the main menu
- ▶ Select **Manual Focus Assist** in the submenu
- ▶ Select **On**

FOCUS PEAKING

This assist function highlights the edges of in focus subject elements in color. The color can be freely selected.

- ▶ Select **SETUP**
- ▶ Select **Capture Assistants** in the main menu
- ▶ Select **Focus Peaking** in the submenu
- ▶ Select the desired color
 - All picture elements that are rendered in perfect focus at the selected distance setting will be marked with a contour in the color of your choice.

Practical Application

- ▶ Select an image section
- ▶ Turn the focus ring to mark the picture elements of your choice
 - All picture elements that are rendered in perfect focus at the selected distance setting will be marked with a contour in the color of your choice.

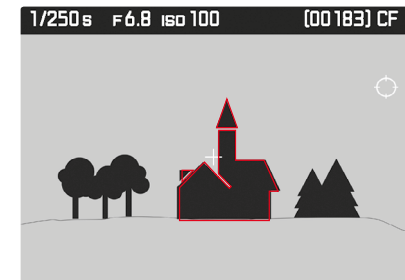

Note

Focus peaking is based on subject contrast, i.e. differences between light and dark. As a result, high contrast subject parts could be marked, even if they are not completely in focus.

ISO SENSITIVITY

The ISO setting covers a range between ISO 100 and ISO 12500 to ensure broad adjustment options for any lighting situation.

In addition to fixed settings, the camera also features the 'ISO Auto' function, where the camera automatically adjusts the sensitivity to ambient brightness and the selected shutter speed/aperture setting. In conjunction with aperture priority mode, this function extends the range for automatic exposure control. There is more leeway for the use of preferred shutter speed and aperture combinations when setting the exposure manually. You can set priorities within the scope of the automatic setting, e.g. for reasons of picture composition.

Notes

- When high ISO values are used or the image is edited later, image noise, as well as vertical and horizontal stripes may become visible, particularly in larger, evenly lit areas of the object.
- When completing a picture series, it must be noted that the image sequence times can slow down at higher sensitivity settings.

If you want to set the sensitivity manually

- ▶ Select **IMAGE**
- ▶ Select **ISO** in the main menu
- ▶ Select the desired value

If you want automatic and unrestricted sensitivity setting

- ▶ Select **IMAGE**
- ▶ Select **ISO** in the main menu
- ▶ Select **ISO Auto** in the submenu

To restrict the automatic setting range

- ▶ Select **SETUP**
- ▶ Select **Auto ISO Setup** in the main menu
- ▶ Select **Auto ISO Photo** in the submenu
- ▶ Select **Maximum Auto ISO** or **Maximum Exposure Time** in the Auto ISO Photo submenu
 - A list of available setting values is displayed for **Maximum Auto ISO**; another submenu with further setting options appears for **Maximum Exposure Time**.

Setting a max. value in the **Maximum Auto ISO** submenu will specify the sensitivity range for automatic settings.

In the **Maximum Exposure Time** submenu, you can either allow the camera to automatically ensure blur-free exposure times (**1/f**, **1/2f**, **1/4f**) or you can select a max. shutter speed manually. In the focal length-specific settings, the camera will only switch to a higher sensitivity if the shutter speed would fall below the set threshold due to low light; for example with a 70 mm lens at speeds slower than 1/60 s at **1/f**, 1/125 s at **1/2f** or 1/250 s at **1/4f**.

Note

The default factory setting **1/f** will result in the slowest shutter speed in accordance with the rule of thumb for manual blur-free exposures, e.g. 1/60 s with Summarit-S 1:2.5/70 ASPH. The shutter speeds with **1/2f** and **1/4f** in this example would be 1/125 s and 1/250 s.

WHITE BALANCE

In digital photography, white balance ensures neutral color rendering in any light. White balance is based on the camera being preset to render a particular light color as white.

Four methods are available:

- automatic control
- fixed presets
- manual setting via metering
- direct setting of the color temperature

AUTOMATIC CONTROL/FIXED SETTINGS

- **AWB** **Auto**: for automatic control, which delivers neutral results in most situations
- eight fixed presets for the most common light sources
 - **Daylight**: for outdoor pictures in sunlight
 - **Cloudy**: for outdoor pictures in cloudy conditions
 - **Shadow**: for outdoor pictures with the main subject in shadow
 - **Tungsten**: for indoor pictures with (predominantly) incandescent lamp light
 - **HMI** **HMI**: for indoor pictures with (predominantly) light from metal halide lamps
 - **Fluorescent Warm**: for pictures with (prevailing) light from fluorescent tubes with warm light color
 - **Fluorescent Cool**: for pictures with (prevailing) light from fluorescent tubes with cool light color
 - **Flash**: for pictures with (predominantly) electronic flash lighting

Note

You can set white balance to **Automatic** for correct color rendering when using Leica system flash units or electronic flash units that satisfy the technical requirements of System 3002 System Camera Adaption (SCA) and have an SCA-3502 adapter (version 5 or higher).

You should, however, use the **Flash** setting in conjunction with a flash unit that is not specifically designed for use with the Leica S3.

- ▶ Select **IMAGE**
- ▶ Select **White Balance** in the main menu
- ▶ Select the desired setting

¹ This function is not available in conjunction with flash units.

DIRECT SETTING OF THE COLOR TEMPERATURE

Values between 2000 and 13100 K (Kelvin) can be set directly. That gives you a very wide range, which covers virtually all color temperatures occurring in real life and within which you can adapt color rendering to any light color and your personal preferences with incredible detail.

- ▶ Select **IMAGE**
- ▶ Select **White Balance** in the main menu
- ▶ Select **Color Temperature** in the submenu
- ▶ Select the desired value

MANUAL SETTING AFTER MEASUREMENT **Greycard**

- ▶ Select **IMAGE**
- ▶ Select **White Balance** in the main menu
- ▶ Select gray card variant: **Greycard** / **Greycard Live View**
 - A message appears on the LCD panel
Please take a picture for setting the white balance.
- ▶ Take the picture
 - Make sure that the image field contains a white or neutral gray (reference) surface.
 - The following will appear on the LCD panel:
 - the image based on automatic white balance
 - cross hairs in the center of the image
 - Instruction for further operation **TL** and **TR**
- ▶ Press the joystick to move the cross hairs onto the subject detail you want to use as basis for the new white balance setting.
- ▶ Press the TL button (**TL** display) or the joystick
 - The color rendering in the image is adjusted accordingly. **TL** is additionally displayed as a hint for further operation.

To apply the new white balance setting

- ▶ Press the BL button (**BL** display)
 - A message appears on the LCD panel: **White balance is set.**

To repeat the entire process

- ▶ Press the TR button (**TR** display)

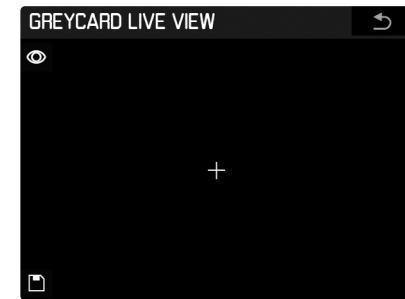

- 1 White balance metering
- 2 Storing the result of the white balance measurement (only active after a measurement)
- 3 Back to normal picture mode (without saving any measurement taken)
- 4 Metering field display

Notes

- The picture used for measuring the white balance is saved alongside the setting.
- The resulting value remains (i.e. is used for all subsequent photographs) until new measurements are taken or another saved white balance setting is selected.

EXPOSURE

EXPOSURE METERING METHODS

Optional methods are Spot metering, Center-Weighted and Multi-Field metering. The line on the left of the light balance will flash in the display if the measuring range is undercut/overshot.

- ▶ Select **CAMERA**
- ▶ Select **Exp. Metering** in the main menu
- ▶ Select a metering method (**Spot**, **Center-weighted**, **Multi-field**)
 - The selected metering method is displayed in the header line of the screen image.

SPOT METERING –

In spot metering, only the center of the image field is scanned and evaluated. This area is indicated by the circle¹ in the center of the focusing screen. In Live View mode, spot metering is linked to the Autofocus metering, i.e. moving the AF metering point also affects the spot metering field.

CENTER-WEIGHTED METERING –

This method considers the entire image field. The subject elements captured in the center will, however, impact on the calculation of the exposure value more so than areas around the edges.

MULTI-FIELD METERING –

This metering method is based on the detection of multiple values. These values are used in an algorithm to calculate an exposure value appropriate for a good rendering of the assumed main subject.

SHIFTING THE AF/SPOT METERING FIELD IN LIVE VIEW MODE

In Live View mode, the metering field can be shifted to any position within the image field using the joystick.

In the two enlarged details, the detail is first moved together with the metering field that remains in the middle. Only when the detail reaches the edge of the image field can the metering field be moved to the edge of the detail by pushing further.

Note





If Spot is used as exposure metering method in Live View mode, its metering field is coupled with the autofocus metering field, meaning that the shift will affect both metering fields.

VALUES ABOVE/BELOW THE MEASURING RANGE

Exact exposure metering is not possible if the metering range falls below that of the camera. The metered values that may still be displayed in the viewfinder can result in incorrect exposure results.

This is why  is generally shown in the viewfinder if the metering range is not reached.

EXPOSURE MODES

You can choose from four exposure modes for optimized adjustment to the relevant subject or to suit your preferred working method: automatic program () aperture priority () and shutter speed priority () plus a manual setting option ()

- ▶ Press and hold the thumbwheel (≥ 1 s)
 - The large letter representing the selected mode shown in the top display replaces the standard display.
- ▶ Turn the thumbwheel (all four operating modes can be reached in either direction)
 - The standard display automatically reappears in the top display shortly after (about 2 s delay) or immediately when the shutter button is pressed to the first pressure point.

Notes

- Set the shutter speed and aperture by turning the thumbwheel and/or the shutter speed setting wheel. In both cases half-increments are available.
- The shutter speed (in **T** and **M**) is always set via the shutter speed setting wheel and the aperture is always set via the thumbwheel. In both cases, half-increments can also be selected.

In the default factory setting, turning the thumbwheel to the right decreases the aperture setting values and turning it to the left increases the values. This can be reversed as needed.

- ▶ Select **SETUP**
- ▶ Select **Customize Controls** in the main menu
- ▶ Select **Rear Wheel Direction** in the submenu
- ▶ Select the direction of rotation

The function of both thumbwheels can be deactivated for complete protection against an accidental change in mode, shutter speed, aperture, etc.; a manual manipulation of the wheels will then not make any changes.

- ▶ Select **SETUP**
- ▶ Select **Keylock** in the main menu
- ▶ Select **On** or **Off**.
 - The relevant icon appears in the top display when **On** is selected and also in the LCD panel (in Live View mode).

¹ This circle is not visible in all focusing screen variants.

AUTOMATIC PROGRAM – P

The automatic program mode facilitates fast and fully automatic photography. The exposure is controlled by an automatic shutter speed and aperture setting. Exposure time and lens aperture are automatically set according to the prevailing light and steplessly between 1/25 s and 1/4000 s, when using the central shutter on some Leica S lenses, and between open and smallest aperture of the respective lens.

Displays

-  for the selected exposure mode
- the automatically controlled shutter speed and exposure values

Notes

- If the automatic sensitivity setting (AUTO ISO) is activated at the same time, the control range of automatic program mode is extended. Even with fully open aperture, however, the shutter speed is only extended beyond the value dictated by the $1/4^1$ setting selected in the menu when the highest set sensitivity is reached.
- With very little light or extreme brightness it is possible that the available shutter speed range is no longer sufficient for the preselected exposure value. In such (extremely rare) cases, a warning icon for underexposure or overexposure will appear in the viewfinder (or a warning message regarding values below the measuring range). Correct exposure metering will then be rendered impossible.

PROGRAM SHIFT

- ▶ Press and hold the thumbwheel (≥ 1 s)
- ▶ Turn the thumbwheel
- ▶ Select 

The program shift function allows the speed/aperture combinations determined in automatic program mode to be changed, while the overall exposure, i.e. the brightness of the image, remains unchanged. Shifting is done via the shutter speed setting wheel.



- for larger apertures (smaller values) or faster shutter speeds.

- ▶ turn to the right

- for smaller apertures (larger values) or slower shutter speeds.

- ▶ turn to the left

Displays

-  in the top display to indicate the use of the program shift function
- the mode display  in the LCD panel changes to 
- the automatically controlled aperture and shutter speed values change inversely

Note

Program shift settings are maintained:

- after a photo is taken
- beyond the 12 s holding time of the exposure metering system, but not when switching to another exposure mode (A, T, M) and when switching the camera OFF/ON (or when using Auto Power Saving). In these cases the camera will initially return to the default setting for shutter speed and aperture when automatic program mode is used again.

APERTURE PRIORITY - A

The camera electronics will calculate the correct shutter speed automatically and steplessly. The calculation includes the set sensitivity, metered brightness and the manually selected aperture.

- ▶ Press and hold the thumbwheel (≥ 1 s)
- ▶ Turn the thumbwheel
- ▶ Select 
- ▶ Set the aperture value
 - The exposure time is then automatically derived from the prevailing light.

Displays

-  (Aperture priority) for the selected exposure mode
- the manually set exposure value
- the automatically controlled shutter speed

Notes

- If the automatic sensitivity setting (ISO Auto) is activated at the same time, the control range of aperture priority is extended. The shutter speed will only be extended beyond the value derived from the $1/4^1$ setting selected in the menu if the highest set sensitivity is reached.
- With very little light or extreme brightness it is possible that the available shutter speed range is no longer sufficient for the preselected exposure value. In such (extremely rare) cases, a warning icon for underexposure or overexposure will appear in the viewfinder (or a warning message regarding values below the measuring range). Correct exposure metering will then be rendered impossible.
- In video mode, the slowest shutter speeds are dependent on the set frame rate.

¹ Applies equally to $1/4$, $1/24$ and $1/44$

SHUTTER SPEED PRIORITY - T

- ▶ Press and hold the thumbwheel (≥ 1 s)
- ▶ Turn the thumbwheel
- ▶ Select 
- ▶ Use the shutter speed setting wheel to set the exposure time
 - The lens aperture is controlled automatically in line with prevailing light and steplessly between open and smallest aperture of the attached lens.

Displays

-  (Time priority) for the selected exposure mode
- the automatically controlled exposure value
- the manually set shutter speed

Notes

- If the automatic sensitivity setting (**ISO Auto**) is activated at the same time, the control range of shutter speed priority is extended. A minimum shutter speed that may have been set there, however, is no longer active.
- With very little light or extreme brightness it is possible that the available aperture range of the lens used is no longer sufficient for the preselected shutter speed. Try setting a different shutter speed.
- The camera will generally still use correct exposure via an automatic setting of a matching shutter speed, i.e. by “overriding” your manual preselection. A warning symbol appears, or a warning message regarding values below the measuring range. Correct exposure metering will then be rendered impossible.

MANUAL SETTING OF APERTURE AND EXPOSURE TIME - M

- ▶ Press and hold the thumbwheel (≥ 1 s)
- ▶ Turn the thumbwheel
- ▶ Select 
- ▶ Use the thumbwheel to set the aperture and the shutter speed setting wheel to set the exposure time

Displays

-  for the selected exposure mode
- the manually set aperture and shutter speed values
- illuminated light balance
 - The light balance highlights the offset of the currently set shutter speed/aperture value against the measured exposure value. The display occurs in clear 1/2 EV increments in the ± 3 EV range. Larger offsets are indicated by a flashing of the outer markings of the light balance.
 - To achieve a correct exposure in accordance with the exposure meter specifications, the aperture and/or shutter speed must be changed until only the zero mark on the light balance is illuminated.

Note

The most recently set sensitivity value will be used if the automatic sensitivity setting (**ISO Auto**) is activated simultaneously. However, a maximum shutter speed that may have been set is no longer active.

EXPOSURE CONTROL/FUNCTIONS FOR AUTOMATIC EXPOSURE**EXPOSURE SIMULATION**

Exposure simulation only works in the Live View photo mode. In the factory setting, the Live View screen image shows the subject in the brightness resulting from the current exposure setting. This exposure simulation allows the effect on the picture to be assessed before the photograph is taken, e.g. during exposure compensation or during manual setting of the exposure. With automatic exposure control (**P, A, T**), on the other hand, the screen image will generally remain equally bright within the relevant setting ranges.

Exposure Simulation ON/OFF

- ▶ Press the Depth-of-field preview button 

METERING MEMORY LOCK

We often want to arrange important subject elements outside the center of the picture for reasons of picture composition and these elements may sometimes be very bright or very dark. Center-weighted metering and spot metering, however, mainly capture an area in the center of the image and are calibrated to an average gray scale value. Subjects or situations like the ones described above can be easily handled using the metering memory lock.

The shutter button and/or the joystick can be used to save the exposure setting (for **P**, **A** and **T**) and the automatic focus (**AF**) – depending on various menu settings.

Notes

- A light balance indicating the offset from the saved measured value is displayed.
- If the aperture and/or exposure time are changed during this period, the relevantly other value will be adjusted and displayed accordingly.

Pressing the shutter button

The **AF** setting is saved – and only in **AFs** mode; the exposure setting can also be saved

- ▶ Select **SETUP**
- ▶ Select **Customize Controls** in the main menu
- ▶ Select **Shutter Button** in the submenu
- ▶ Activate the function (**AE Lock ON**)
- ▶ Place the cross hairs in the viewfinder over the subject element you want to focus on
- ▶ Tap the shutter button
 - The measurement is taken and saved.
 - The stored value remains active as long as you hold the pressure point.
 - The shutter button memory function only applies for a single exposure.
- ▶ Selecting the final image section
- ▶ Shutter release

Using the joystick (in Live View mode only)

- ▶ Press the LV button
 - ▶ Use the joystick to zero in on the subject element you wish to bring into focus on the LCD panel
 - ▶ Press the joystick
- or
- ▶ Tap the shutter button
 - The measurement is taken and saved.
 - The stored value remains active as long as you hold the pressure point.
 - The shutter button memory function only applies for a single exposure.
 - ▶ Selecting the final image section
 - ▶ Shutter release

Notes

- The exposure and **AF** settings can be stored. There are various function combinations available, which you can define via menu control.
- The storage function of the joystick remains active while it is held, i.e. for any number of pictures and even if the shutter button is pressed simultaneously.
- The storage function of the joystick applies to the **AFs** and the **AFc** mode.

The joystick for in AF/MF mode

- ▶ Select **SETUP**
- ▶ Select **Customize Controls** in the main menu
- ▶ Select **AF/AE Lock Button** in the submenu
- ▶ Select **In AF Mode** or **In MF Mode**

In AF Mode

Working method of the three function options:

- **AF/AE-Lock** (factory settings)
 - Shutter button: **AFs** setting
 - Joystick: exposure setting, **AFs/AFc** setting
- **AE-L**
 - Shutter button: **AFs** setting
 - Joystick: Exposure setting
- **AF-Lock**
 - Shutter button: **AFs** setting
 - Joystick: **AFs/AFc** setting

- ▶ Select option

In MF Mode

When setting the sharpness manually, you can still activate AF mode temporarily, i.e. for the relevant picture, by pressing the joystick and/or save the exposure setting – depending on the current settings.

Working method of the three function options:

- **AFs On / AE-Lock** (factory settings)
 - **AFs** operation is activated for one exposure, the exposure setting is saved
 - The implemented AF setting is retained until it is changed by a manual adjustment or by pressing the button again.
 - **AFs ON**
 - The same as **AFs ON/AE-Lock** but without saving the exposure setting
 - **AFc On / AE-Lock**
 - The same as **AFs ON/AE-Lock** but in **AFc** mode
 - **AFc ON**
 - The same as **AFs ON/AE-Lock** but without saving the exposure setting
 - **AE-Lock**
 - Saving the exposure setting
- ▶ Select option

EXPOSURE COMPENSATION

Exposure meters are calibrated for a medium gray scale value (18% reflection), which matches a standard, i.e. average image subject. Should the measured image detail not fulfill that requirement, then the a relevant exposure compensation can be effected.

Specifically where several pictures are taken in sequence, for example if for a series a slightly lesser or greater exposure is desired for a particular reason, then exposure compensation can be a very useful function: Once set, the setting remains active – unlike the metering memory lock – until it is reset.

Exposure compensation can be set in the ± 3 EV range in half increments, which can then be used in the modes automatic program (P), shutter speed priority (T) and aperture priority (A) (EV = Exposure Value).

- ▶ Select **CAMERA**
- ▶ Select **Exp. Compensation** in the main menu
 - The submenu displays a scale with a red setting mark. The function is deactivated if the value is set to 0.
- ▶ Set the desired value
 - The initial menu list shows a correction set via **EV+X**¹

Notes

- This menu function can be accessed directly in the default factory settings by pressing and holding the BR button.
- An exposure compensation setting on the camera will only affect the measurement of available light, and not the light from the flash

AUTOMATIC BRACKETING

Many attractive objects are rich in contrast, which means they have very bright and very dark areas. The image effect can be dramatically different, depending to which of these you align your exposure. In these cases, the automatic bracketing function in aperture priority mode allows you to produce several alternatives with graduated exposure, i.e. using different shutter speeds. You can then select the picture you like best or use relevant picture editing software to calculate an image with a particularly broad contrast spectrum (HDR).

You can choose from 4 graduations (**0.5 EV**, **1 EV**, **2 EV**, **3 EV**) and 3 or 5 recordings per series.

- ▶ Select **CAMERA**
- ▶ Select **Exp. Bracketing** in the main menu
- ▶ Activate the function (**ON**) in the submenu under **Exp. Bracketing**
- ▶ Select the desired number of pictures in the submenu under **Frames**
- ▶ Select the desired exposure offset between pictures in the submenu under **F-Stops**
 - The marked exposure values change positions according to the settings selected. In the case of exposure compensation, the scale also shifts.
- ▶ In the submenu **Automatic**, select whether you want to take each picture individually (**OFF**) or all pictures by pressing the shutter button once (**ON**).
 - A set bracketing series is indicated in the initial menu list by **X/Y EV**¹.
- ▶ All pictures are taken by pressing the shutter button once or several times

Notes

- The **Exp. Bracketing** function is not available if an interval picture series has been set up.
- Depending on the exposure mode, the exposure gradations are produced by changing the shutter speed and/or aperture.
- The sequence of exposures is as follows: overexposure, correct exposure, underexposure
- All **ISO Auto** settings are set when you use automatic bracketing:
 - The sensitivity calculated by the camera automatically for the raw picture will also be applied to all other pictures in a series, i.e. the ISO value will not change while bracketing.
 - The settings in the **AUTO ISO** submenus are invalid, i.e. the full shutter speed range of the camera is available.
- The focus range for automatic bracketing may be limited (depending on the initial exposure setting).
- The set number of pictures will be taken regardless, which may result in multiple pictures at the end of a series taken with the same exposure setting.
- The function remains active until it is deactivated in the menu, or the camera is switched off.

¹ Example: either plus or minus, "X" stands for the relevant value



¹ "X" stands for the number of pictures, "Y" for the graduation

LONG-TERM EXPOSURE (B)

In B setting, the shutter remains open as long as the shutter button is pressed and held (at most to max. exposure time).

An additional T function is available in conjunction with the self-timer: When  is set and the self-timer is simultaneously activated by pressing the shutter button, then the shutter will open automatically after the selected delay time. It then remains open until you press the shutter button a second time – you do not need to hold the button down. This will prevent virtually all camera shake from pressing the shutter button in long-term exposures. The exposure meter remains deactivated in both scenarios.

Displays

-  instead of a shutter speed
-  in the top display
- remaining exposure time after opening the shutter

Notes

- The longest available exposure time depends on the set sensitivity.
- Long exposure times may result in picture noise. Your Leica S3 automatically takes a second "black picture" (taken with the shutter closed) to reduce this annoying phenomenon, when a picture is taken with slow shutter speed. The noise metered in this parallel picture is then digitally "subtracted" from the data for the actual picture.
- The doubling of the "exposure" time must be taken into account for long exposure times. The camera must not be switched off during that time.
- We recommend attaching the supplied eyepiece cover when taking pictures with long-term exposure. This prevents any unwanted additional exposure.
- If the shutter speed exceeds 1/2 s, **Noise Reduction** is displayed in the LCD panel.
- Long-term exposures in **B** setting are always taken with the camera's internal focal plane shutter, even if the main switch is set to **CS**.

OTHER FUNCTIONS

DEPTH OF FIELD

The Leica S3 allows you to close the lens aperture in any exposure mode at the set or automatically calculated exposure value. In factory settings, this is done by pressing the Depth-of-field preview button.

The correct values are displayed on the LCD panel and top display, and also on the LCD display in Live View mode. Exposure metering will, however, be deactivated.

Prerequisites for stopping down:

- exposure metering is activated via the shutter button
- the shutter button is not pressed (anymore).

Shutter release is blocked while the Depth-of-field preview button is pressed and held.

(For more information about the functions of the Depth-of-field preview button see p. 25)

AUXILIARY DISPLAYS IN LIVE VIEW MODE

The auxiliary displays Histogram, Grid lines, Clipping and Horizon are available in Live Mode.

Activating the auxiliary displays:

- ▶ Press the BR button
 - The displays are shown in sequence. Press the button repeatedly until the desired display appears.
 - Histogram and Clipping displays
 - Focus Peaking display (see p. 35)
 - Grid lines and Horizon
 - Extended picture data
 - Back to standard view

HISTOGRAM

Histogram represents the brightness distribution in the picture. The horizontal axis shows the graduated values from black (left) through gray to white (right). The vertical axis corresponds to the number of pixels at each brightness level.

This form of representation – in conjunction with the impression of the actual image – allows an additional quick and easy assessment of the exposure setting.

Notes

- The display always refers to the currently shown cropped section.
- This function is also available in Review mode.

GRID LINES

The grid divides the image frame into nine equal fields. It helps with e.g. picture composition and camera orientation. You can choose one of two grid displays. They divide the frame into 3 x 3 or 6 x 4 fields.

- ▶ Select **SETUP**
- ▶ Select **Capture Assistants** in the main menu
- ▶ Select **Grids** in the submenu
- ▶ Select a grid type (**3x3**, **6x4**)

CLIPPING

The Clipping display marks bright or dark areas in the image lacking definition (bright areas flash in red; dark areas flash in blue). To adjust these displays to specific conditions or your compositional ideas, you can specify limit values, i.e. the level of over/underexposure at which they appear. The Clipping display therefore offers a very simple and exact means for checking and adjusting your exposure settings.

- ▶ Select **SETUP**
- ▶ Select **Capture Assistants** in the main menu
- ▶ Select **Exposure Clipping** in the submenu
- ▶ Activate the function (**On**) or deactivate it (**Off**) in the submenu **Clipping Enabled**
 - The two other lines are not selectable (= gray) when the function is deactivated.
- ▶ Optional: Set the desired lower and upper limit values in the **Lower Limit** and **Upper Limit** lines.

Notes

- The display always refers to the currently shown cropped section.
- The scale indicates the clipping areas in relation to the total exposure range.
- This function is also available in Review mode.

HORIZON

The integrated sensors of the Leica S3 show the camera's alignment in relation to the image. These displays ensure exact camera orientation along the longitudinal and transverse axes of critical subjects, e.g. architecture.

The relevant display always appears in the viewfinder, and on the LCD panel only when the BR button is pressed.

- If the view with horizon and grid is selected, a vertical scale and a horizontal bar appear in the LCD panel. The horizontal orientation along the longitudinal and transverse axes is indicated by a solid green line in the center; deviations from the zero position are indicated by a dotted red line.

Notes

- Display accuracy is $\leq 1^\circ$.
- The display changes automatically for portrait format pictures.

MIRROR UP MODE

The Leica S3 offers a Mirror up mode to eliminate the minimal effects of the mirror movement.

- ▶ Select **CAMERA**
- ▶ Select **Mirror Up Mode** in the main menu
- ▶ Select **On** or **Off**.
- ▶ Press the shutter button down fully to fold up the mirror.
- ▶ Press the shutter button again to take the picture.

Procedure

Tapping the shutter button:

1. will initiate exposure metering
2. then the camera focuses (if set to autofocus mode)
3. folds mirror up
4. the aperture closes to the appropriate value
 - The picture must be taken within 2 minutes of the shutter button being actuated for the first time. If that is not the case, the mirror automatically folds back down to save battery capacity (without the shutter opening).
 - While the mirror is folded up, the 2 minute hold time can be restarted at any time by pressing the shutter button again.

When the shutter button is pressed again:

- the shutter process commences (the picture is taken)
 - Then the mirror folds back down and the aperture opens again as usual.

Canceling the function

- ▶ Tap the shutter button
 - No picture is taken.

Notes

- The function is canceled by switching off the camera on the main switch; the mirror folds back down.
- When the Mirror Up mode is set, the function will remain active even after the camera is switched off and on again, i.e. the function must be set to **Off** in the menu if you don't want to use the Mirror Up mode for the next picture.
- When the functions Mirror Up and Self-timer are simultaneously set, then the picture will be taken, once the selected delay time has elapsed – without having to press the shutter button again.

FRAME

In addition to the default aspect ratio (2:3) for photos, three further ratios are available when using the DNG format: 1:1, 16:9, 2:1. These offer additional image composition options while taking the picture.

- ▶ Select **SETUP**
- ▶ Select **Capture Assistants** in the main menu
- ▶ Select **Photo Masks** in the submenu
- ▶ Select a value
 - The screen image is framed accordingly, with 1:1 left and right, with 16:9 and 2:1 top and bottom. While taking the photograph the frame is transparent, during review of corresponding photos in the camera it is not.

Note

Irrespective of the aspect ratio selected, the whole 2:3 image field is always recorded, i.e. the frame in the screen image affects only the display in the camera. Although the photo is initially displayed with the selected aspect ratio in image processing programs, but it is possible to delete the frame there so that the entire 2:3 image field is usable.

SERIAL EXPOSURES

The camera is set to single shot exposures by default. You can also take serial exposures to e.g. capture motion sequences at various stages. Decide whether to take single shots or serial exposures via menu control. Your Leica S3 can take picture series with a frame rate of approx. 3 fps.

- ▶ Select **CAMERA**
- ▶ Select **Drive Mode** in the main menu
- ▶ Select **Continuous** in the submenu

Once you have selected your setting, the camera will take serial exposures as long as you keep the shutter button pressed down fully and you have sufficient space on your memory card. Tapping the shutter button will take additional single shots.

Notes

- The stated picture sequence and the max. number of pictures in a series are connected to a default setting. Frequency and total number may vary depending on other settings, e.g. white balance or the image content and the memory card used.
- Regardless of how many pictures were taken in a series, the last picture in the series or the last picture in the series or the last picture saved on the memory card while the saving process is ongoing will be displayed first in both review modes.

INTERVAL SHOOTING

This camera allows you to capture motion sequences over extended periods of time automatically using the interval shooting function. You must specify the interval between shots and the number of frames in the series.

Specifying the number of pictures

- ▶ Select **CAMERA**
- ▶ Select **Drive Mode** in the main menu
- ▶ Select **Interval** in the submenu
- ▶ Select **Frames**
 - A number pad submenu will appear (see p. 28).
 - Any new setting entered via the number pad submenu will overwrite any previously set number.
 - You can enter a number between 1 and 9999.

Specifying the intervals between shots

- ▶ Select **CAMERA**
- ▶ Select **Drive Mode** in the main menu
- ▶ Select **Interval** in the submenu
- ▶ Select **Interval Time**
- ▶ Select the desired interval between shots
- ▶ Press down the shutter button to start the series

Notes

- The camera will automatically use the factory settings if no number is entered.
- The function remains active until it is deactivated via the menu.

Canceling a running interval shooting

- ▶ Press the TL button, BL button or the BR button
 - Continue by pressing the shutter button again.

Starting a new series during a current interval shooting

- ▶ Press the shutter button

Notes

- The camera's buffer memory allows only a limited number of pictures in series.
- The camera may switch off and on again if "Auto power off" is set and no other camera operation occurs between the individual shots.
- Interval shooting over an extended period of time in a cold location or in a place with high temperature and humidity may result in malfunctions.
- Interval shooting will be interrupted or canceled in the following situations:
 - if the battery is depleted
 - if the camera is switched off
 - if the inserted memory card is full
 Make sure to use a sufficiently charged battery.
- Interrupted or canceled interval shooting can be resumed by switching the camera off, replacing the battery or memory card as needed and then switching the camera back on. The pictures taken after function interruption will be stored in a separate group.
- The interval function remains active after a picture series is completed, and also after the camera is switched off and on again. You will have to change functions in the **Drive Mode** submenu if you want to exit the mode. A prompt will be displayed on screen if the camera is switched off and on again while the **Interval** shooting function is active.
- The availability of this function does not mean that the camera is suitable for use as a monitoring device.
- Regardless of how many pictures were taken in a series, the last picture in the series or the last picture in the series or the last picture saved on the memory card while the saving process is ongoing will be displayed first in both review modes.

SELF-TIMER

You can use the self-timer to take a picture with a delay of either 2 or 12 s. This is useful for group photographs in which you want to be included or if you want to avoid blurring caused by an unsteady hand. We recommend that the camera is placed on a tripod.

- ▶ Select **CAMERA**
- ▶ Select **Drive Mode** in the main menu
- ▶ Select **Self Timer 2 s** or **Self Timer 12 s** in the submenu, depending on which delay time you want.
- ▶ Shutter release
 - With 2 s delay time:
 - Exposure metering is completed first; in Autofocus mode, the mirror folds up when focusing is completed. The delay time only starts after this.
 - With 12 s delay time:
 - The delay time starts when the shutter button is pressed down fully and the mirror folds up 2 s before the picture is taken
 - A flashing LED at the front of the camera counts down the first 10 s time delay if 12 s delay were selected. The same countdown is shown in the LCD panel.
 - The delay time can be restarted/delayed at any time by pressing the shutter button again.

Canceling the countdown of the running self-timer delay time

- ▶ Switch the camera off on the main switch
- or
- ▶ Press the TR/BR/TL/BL button (only available during the initial 10 s of a 12 s delay time)

Note

If you no longer wish to use the self-timer, it must be deactivated in the menu as even switching off the camera will not delete the settings for this function.

FLASH PHOTOGRAPHY

This camera determines the required flash output by firing several pre-flashes in rapid succession, fractions of a second before taking the actual picture. The main flash fires immediately after, at the start of exposure.

All factors influencing exposure (e.g. filters, aperture settings, distance to the main subject, reflective ceilings, etc.) are automatically considered.

COMPATIBLE FLASH UNITS

The following flash units enable all Leica S3 functions described in this manual:

- Leica system flash units
- Flash units that satisfy the technical requirements of a system 3002 System Camera Adaptation (SCA), are equipped with the adapter SCA-3502-M5^{1,2} and allow guide number (GN) control.
- Other commercially available flash attachments with a standard flash foot^{3,4} and a positive center contact, which are fired via the center contact (X contact) can also be used (without TTL flash control).

CONNECTION VIA FLASH SHOE

All flash units and studio flash systems that meet the currently valid ISO standard 10330, and the older DIN 19014 standard (positive polarity at the X contact).

Note

Please contact the Leica Camera AG Customer Service department or the service department at a Leica subsidiary near you if you wish to connect a studio flash system to the Leica S3 that does not comply with the ISO standard.

CONNECTION VIA THE LOWER LEMO® JACK

All flash units and studio flash systems that can be cable controlled can be connected.

CONNECTION VIA THE FLASH CONNECTION JACK

All studio flash systems and other flash units with flash cable and standard flash jack can be connected.

ATTACHING THE FLASH UNIT

- ▶ Switch off the camera and flash unit
- ▶ Slide the foot of the flash unit all the way into the accessory shoe and use the clamping nut (where available) to secure it against accidental detaching.
 - Movement inside the accessory shoe can interrupt required contacts and therefore cause malfunctions.

Note

The camera and flash unit must be switched off before the connection is made.

FLASH EXPOSURE METERING (TTL METERING)

A fully automatic, camera-controlled TTL flash operation is available in the Leica S3 for all exposure modes in conjunction with system-compatible flash units. An additional brightening control is provided. Should the ambient brightness require a shorter shutter speed than the sync speed (1/125 s with focal plane shutter, 1/1000 s for lenses with central shutter) or if it is set manually, then any system-compatible flash unit will automatically be switched to linear flash mode (HSS, see next section). The Leica S3 additionally communicates the sensitivity and aperture setting to the flash unit. The flash unit can therefore automatically adjust the range information, provided the device comes with these displays.

Notes

- The settings and functions described in the following sections only apply to those available in the Leica S3 and system-compatible flash units.
- An exposure compensation set on the camera will only affect the measurement of available light. Additional settings on the flash unit will be required if you want to simultaneously use compensation of the TTL flash exposure metering in flash mode (parallel or opposed).
- Please read the relevant instructions provided with the device for more information about flash use and the various available flash modes when using flash units that are not designed specifically for use with Leica S3.

¹ When using the SCA-3502 adapter (version 5 or higher), the white balance can be set to *Automatic* to ensure correct color rendering.

² The use of third party system flash units or SCA adapters of other camera systems is not recommended, as their differing contact positions and assignment may cause malfunctions or device damage.

³ White balance should be set to  (manually if necessary) where flash units are used that are not designed specifically for the camera.

⁴ The aperture and sensitivity specified at the lens may have to be entered manually on the flash unit.

FLASH MODES

AUTOMATIC (A)

- ▶ Switch on the flash unit
- ▶ Set the flash mode for TTL operation
- ▶ Tap the shutter button before each flash exposure to activate exposure metering
 - The viewfinder display switches to the shutter speed or light balance value.
 - The flash unit may not fire if this step is missed by pressing the shutter button down completely and skipping these settings.
- ▶ Set the desired exposure mode, shutter speed and/or aperture setting
 - Take note of the shortest flash sync speed, as it determines whether a "normal" flash or an HSS flash is fired.

FLASH PHOTOGRAPHY WITH AUTOMATIC EXPOSURE

When a flash unit is used that is system-compatible with the automatic exposure function, then the light reflected by the subject will be measured and analyzed by a sensor integrated in the flash unit and not by the camera. The camera's exposure modes essentially function the same way as without flash: The flash will not fire if the flash sync speed drops below the set value for **P** or **A**, or if a speed below the sync speed is set for **T** or **M**.

The flash output should be reduced, i.e. a flash exposure compensation of e.g. -1 EV to -2 EV should be set in that case, because the operating modes will already produce a regularly lit exposure with ambient light. In system-compatible flash units, the aperture set at the lens is transmitted to the flash unit and automatically used as the basis for computer aperture. The sensitivity set in the camera and any exposure compensation set for ambient light (camera) and flash (flash unit) will be considered for the measurement.

HSS (HIGH SPEED SYNC.)

Automatic flash activation for **fast** shutter speeds

A fully automated, camera-controlled linear flash mode is available in the Leica S3 in conjunction with system-compatible flash units (see p. 47) for all shutter speeds of the camera. It is activated by the camera automatically if the selected or calculated shutter speed is faster than the sync speed ($\leq 1/125$ s with focal plane shutter).

FLASH CONTROL

FLASH RANGE

(Selecting the sync speed/sync speed range)

The Leica S3 allows you to fine tune the shutter speed used in flash mode in combination with the exposure modes Automatic and Aperture Priority to the exact conditions of the subject or your own picture composition ideas. You can choose an automatic setting or one of several manual settings.

- ▶ Select **CAMERA**
- ▶ Select **Max. Flash Sync Time** in the main menu
- ▶ In the submenu, select one of the three automatic focal length-specific settings (**1/f**, **1/(2f)**, **1/(4f)**) or the desired slowest shutter speed

Note

The **1/f** setting results in the slowest shutter speeds based on the rule of thumb for blur-free pictures taken manually, e.g. $1/60$ s using the Summarit-S 1:2.5/70 ASPH. The shutter speeds with **1/(2f)** and **1/(4f)** would in this example be $1/125$ s and $1/250$ s respectively.

SYNC POINT

Your Leica S3 allows you to choose the flash firing point at the start of the exposure or the sync point at the end of the exposure.

This function is available with all flash units (including system-incompatible flash units), regardless of whether they are fitted to the flash shoe or are connected via cable, as well as for all camera and flash unit settings. The displays are identical in both cases.

- ▶ Select **SETUP**
- ▶ Select **Flash Sync. Mode** in the main menu
- ▶ Select the desired variant

FLASH SYNC SPEED

The flash sync speed of the Leica S3 is $1/125$ s with regular flash technology, i.e. with the camera's own focal plane shutter. All shutter speeds up to $1/1000$ s are available if the central shutter is used with relevantly equipped lenses.

All faster shutter speeds are available as well when using system-compatible, HSS-capable flash units.

Notes

- Specifically studio flash systems often have flash times that are significantly longer than the sync speeds listed above. Longer times are recommended in order to use of the light of these flash units to full effect.
- **X** will light up in the viewfinder for all shutter speeds up to the sync speed of $1/125$ s to indicate that the standard flash mode can be used.
- If the shutter speed setting dial is raised, the preset exposure modes may change from **P** to **T** or from **A** to **M** because of the shutter speeds that will then be set. The original modes will be reset once a new shutter speed is provided.
- The flash unit automatically switches to HSS mode if a HSS-capable Leica system flash unit is used and shorter shutter speeds are set on the camera ($\leq 1/125$ s with a focal plane shutter, and $\leq 1/1000$ s with a central shutter).

STROBOSCOPE FLASH MODE

(with system-compatible flash units)

This flash method, in which several flashes are fired during an exposure, is available in all exposure modes of the camera. The camera will automatically set the shutter speed needed for selected number of flashes and their frequency using the flash modes. The light balance display will indicate if the required shutter speed would result in an overexposure because of the available light. Where the shutter speed would result in a too short shutter speed, the time display in the viewfinder and in the top display will flash. Changing the number of flashes and the flash frequency, the aperture and/or the shutter speed will help to compensate the exposure. The focus range of the flash unit, number of flashes, distance, and of course the aperture are crucial factors when trying to capture successful stroboscopic images, where several phases of a motion sequence are captured. Please read the flash unit manual for more information.

Note

HSS flash technology offers less range.

MANUAL FLASH PHOTOGRAPHY WITH UNIFORM FLASH OUTPUT

The flash output volume will not be controlled if the flash unit is used in manual flash mode at full power or at permanent partial power (provided the flash unit offers this setting option). The camera's exposure modes essentially function the same way as without flash.

The flash is suppressed if the flash sync speed drops below the set value in mode **A** or **T** or if a speed is set below the sync speed in mode **T** or **M**. The lens aperture to be set is determined by the flash output, the sensitivity and the distance to the subject. Conversely, the partial flash output to be set is determined by the aperture, the sensitivity, the focal length and the distance to the subject (see flash unit manual).

FLASH PHOTOGRAPHY VIA THE LOWER LEMO® JACK

Flash units and large studio flash systems can be connected to the lower LEMO® jack via a cable using the LEMO® plug (supplied). The LEMO® jack comes with an automatic lock to prevent accidental disconnection. The camera cannot "recognize" the flash unit and will therefore behave as if no flash unit was attached. The exposure time must be set manually to the flash sync speed 1/125 s or 1/1000 s with central shutter, or to slower speeds. There will be no automatic switch-over. The flash ready and control displays are not active.

FLASH EXPOSURE DISPLAYS IN THE VIEWFINDER

(with system-compatible flash units)

The flash icon in the viewfinder display of the Leica S3 reports and indicates various operating states.

⚡ does not appear (despite the flash unit being switched on and ready)	The flash unit cannot fire. A correct operating mode must be set on the flash unit.
⚡ <u>flashes</u> before the picture is taken	The flash unit is not ready.
⚡ <u>lights up</u> before the picture is taken	The flash unit is ready.
⚡ remains continuously lit after firing	The flash is still ready.
Exposure compensation is set	± is displayed as well.

VIDEO MODE

This camera also has video capability.

Notes

- The full sensor width is used for video recording, which means the relevantly effective focal length increases slightly, i.e. cropped sections are similarly only marginally smaller.
- You can record up to 29 minutes of uninterrupted video.

STARTING/ENDING THE RECORDING

Start

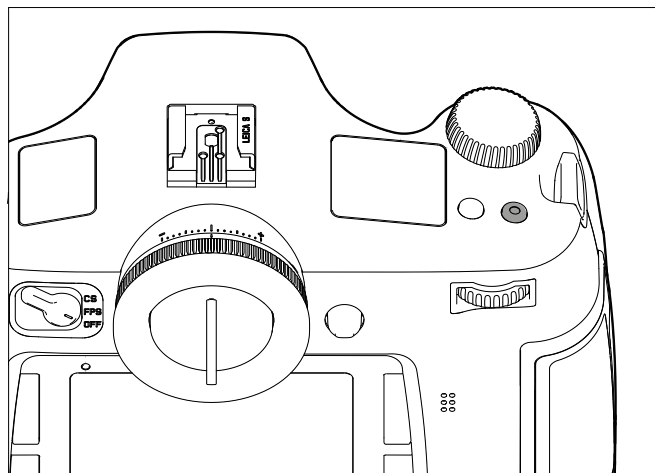

- ▶ Press the video button

End

- ▶ Press the video button again

Notes

- A video recording in progress is indicated on the LCD panel by a flashing red dot and a counter of the elapsed recording time.
- The screen image of video recordings with the Leica S3 appears with corresponding frame depending on the selected resolution and aspect ratio.

VIDEO SETTINGS

The following settings are available for video recordings.

RESOLUTION

- ▶ Select **IMAGE**
- ▶ Select **Video Resolution** in the main menu
- ▶ Set the desired resolution

The two available resolutions are permanently linked to various image frequencies. 1080p can be combined with three different image frequencies to match playback to the TV system used: 25 B/s for PAL, 24 and 30 B/s for NTSC; the 4 K resolution is only available with 24 B/s.

Note

4 K video recordings can only be stored on SD cards.

ISO SENSITIVITY

All variants described on p. 36 apply, but **Maximum Auto ISO** for video recordings is set separately in the **Auto ISO Video** submenu.

Notes

- The restriction described in the section about exposure modes (see p. 50) applies.
- Vertical and horizontal strips may appear across the entire image, when recording dark subjects with high ISO values that contain very bright, dot-like light sources.

IMAGE PROPERTIES

COLOR SPACE

Video is generally recorded in the sRGB color space (see p. 32).

Note

This applies irrespective of any other setting for photos, which remains unchanged.

CONTRAST, SHARPNESS, SATURATION

All variants described on p. 32 apply, but are set individually for video recordings.

- ▶ Select **IMAGE**
- ▶ Select **Video Settings** in the main menu
- ▶ Select **Video Contrast/Video Sharpness/Video Saturation** in the submenu
- ▶ Select the desired level in the corresponding submenu

TIME CODE

The time code is a data record that is generated and recorded in addition to the image and audio data. It ensures the correct time assignment of picture and audio signals after cutting or after later separate processing. You can choose between a continuous running time code – **Free Run** or a time code for the relevant recording – **Rec Run**.

- ▶ Select **IMAGE**
- ▶ Select **Video Settings** in the main menu
- ▶ Select **Timecode** in the submenu
- ▶ Select **Timecode Mode** in the Timecode submenu
- ▶ Select a function (**Camera Time**, **Rec Run**, **Free Run**) or deactivate a function (**Off**)

The time code signal is generally created and recorded alongside the video recording. You can, however, specify the time code start using **Free Run** and **Rec Run**. You will therefore specify the length of the time delay between the start of the recording and the start of the time code signal generation. The otherwise disabled second line of the **Timecode** submenu can therefore be set.

- ▶ Select **Timecode Mode** in the submenu
- ▶ Select **Starttime**
- ▶ Select the desired delay

EXPOSURE METERING METHODS

All variants described on p. 38 apply.

EXPOSURE MODES

- Aperture Priority (see p. 39)
- Manual control with shutter speeds of 1/30 – 1/4000 s
 - Slower set shutter speeds are treated like 1/30 s.

Notes

- ISO sensitivity will be increased automatically if correct exposure cannot be achieved with the largest aperture – no matter what values were set manually.
- Automatic exposure control takes into account any fluctuations in brightness. Exposure should be set manually where that is undesirable, e.g. for landscape recordings and pans.

FOCUSING

All variants described on p. 34 apply.

AUDIO LEVEL

Sound can be recorded using the integrated microphones or with external microphones connected via the supplied LEMO® audio adapter. The integrated microphones record in stereo.

Note

The automatic distance setting (autofocus) function generates noises that will also be recorded.

Automatic or manual modulation is available before and during video recording.

- ▶ Select **IMAGE**
- ▶ Select **Video Settings** in the main menu
- ▶ Select **Audio Level** in the submenu
- ▶ Set the desired function

MANUAL VOLUME ADJUSTMENT

- ▶ Press and hold the depth of field preview/function button
- ▶ Push the joystick to the left (= decrease level) or the right (= increase level)

Note

Make sure to set the volume to a level that prevents over modulation and the bars on the far right do not or only rarely change from white to red.

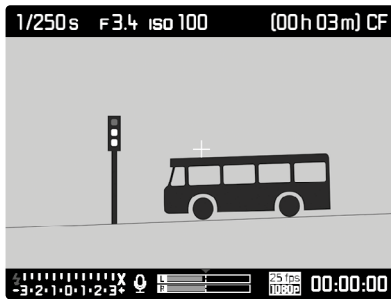

- 1 Microphone (🔊) = Automatic modulation, (🔇) = Manual modulation, (🔇) = No sound recording
- 2 Setting mark
- 3 Left channel level
- 4 Right channel level

Note

Level control occurs simultaneously for both channels.

DEACTIVATE SOUND RECORDING

Move the setting mark to the far left until the microphone symbol changes from (🔊) to (🔇).

WIND NOISE DAMPING

A damping function is provided under “Audio Wind Elimination” to reduce wind noise during sound recording.

- ▶ Select **IMAGE**
- ▶ Select **Video Settings** in the main menu
- ▶ Select **Audio Wind Elimination** in the submenu
- ▶ Activate (🔊) or deactivate (🔇) the function.

Note

(🔇) should always be selected for the best possible sound quality whenever wind noise is not expected.

CHECKING THE SOUND RECORDING

You can connect headphones to check your sound modulation at the time of recording.

- ▶ Connect the headphones to the camera via the LEMO® audio jack using the audio adapter S (supplied).
 - A corresponding icon appears in the screen image

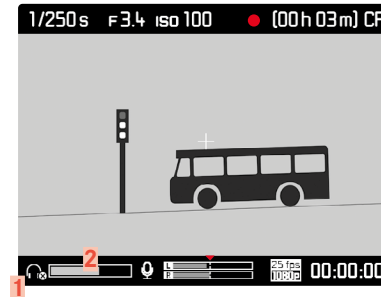

- 1 Icon for connected headphones
- 2 Volume bar

SETTING THE HEADPHONE VOLUME

- ▶ Press and hold the depth of field preview/function button
- ▶ Push the joystick down (= reduce volume) or up (= increase volume)

TAKING PHOTOGRAPHS DURING A VIDEO RECORDING

Single shots (stills) can be taken while a video records.

- ▶ Press the shutter button **1**
 - Video recording is interrupted for the time it takes to take the single shot.
 - The stills are taken with the current camera settings.

PLAYBACK/REVIEW MODE

PHOTO REVIEW

Picture review mode

- There is no time limit for reviewing pictures
- Short-term rendering of the picture on the display directly after exposure (**Auto Review Screen Target**)

PICTURE REVIEW

- ▶ Press the TR button
 - The picture taken most recently is displayed first with its relevant settings.
 - The following message appears if the inserted memory card does not contain any picture data: **No media file to display.**

AUTOMATIC REVIEW OF THE LAST RECORDING

The **Auto Review Screen Target** function allows you to view each picture right after it was taken. That allows you to check whether the shot was successful or should be taken again. The function additionally allows – possibly in conjunction with the shutter button – to set the length of time the picture will be displayed.

- ▶ Select **SETUP**
- ▶ Select **Auto Review Screen Target** in the main menu
- ▶ Select the desired function and/or duration in the submenu (**Off**, **1 s**, **3 s**, **5 s**, **Permanent**)

Note

The picture will remain on the display if the shutter button is still held down fully after the picture is taken. This function is not available if **Off** is selected.

You can switch back from **Auto Review Screen Target** mode to the standard review mode without time limit at any time.

Notes

- Even pictures that have not been transferred from the buffer memory of the camera to a memory card (the bottom right LED on the rear of the camera is still flashing) can be viewed immediately. In contrast, recordings on the memory cards cannot be accessed while a data transmission is in progress.
- Both review modes show the last picture in the series or the last picture in the series saved on the currently active card while saving is still ongoing if pictures were taken using the bracketing/interval function. Details of how to select the other pictures in the series and further options in review mode are described in the following sections.
- The picture is displayed in the selected aspect ratio if the frame function was used when the picture was taken (see p. 45).
- Only picture data captured with Leica S3 cameras can be displayed with the Leica S3.
- If the picture data is stored in JPG and DNG format at the same time, the displayed picture is generally always based on the DNG file.

VIDEO PLAYBACK

A video recording can be identified by the following features:

- Image format (16:9 in full HD, approx. 17:9 at 4K)
- Additional video-related information provided in the footer
- A field with the video and audio control symbols is displayed on the left when the camera is switched on or the joystick is pressed:

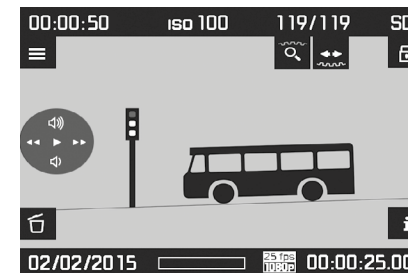

To play back a video (▶):

- ▶ Press the joystick

To pause:

- ▶ Press the joystick

To fast forward (▶▶):

- ▶ Press and hold the joystick to the right

To fast rewind (◀◀):

- ▶ Press and hold the joystick to the left

Note

The fast forward and rewind functions start in slow motion and become faster the longer the button is pressed in that direction.

To jump directly to the start or end of the video:

- ▶ Turn the thumbwheel
(to the left = back to start, to the right = forward to the end)

To increase volume (🔊):

- ▶ Move the joystick **up**

To decrease volume (🔇):

- ▶ Move the joystick **down**

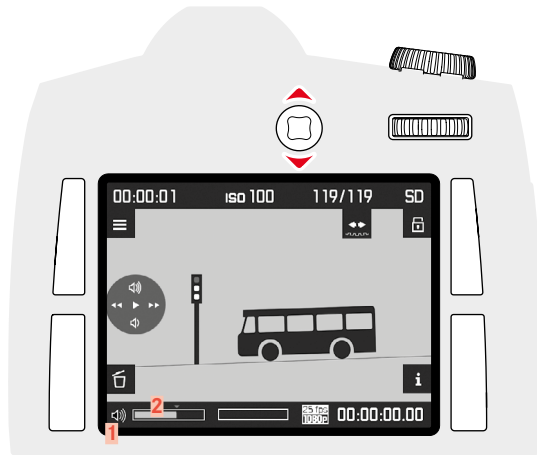

1 Symbol for camera speaker/connected headphones

2 Volume bar; the sound is switched off when in the far left position on the bar (🔇/🔊).

DISPLAYS IN PLAYBACK MODE

The following are the only displays appearing in playback mode so as to not infringe on your viewing pleasure:

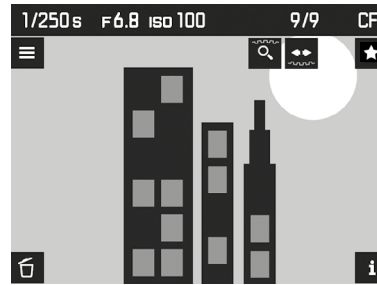

- basic information in the header line
- in the four corners of the screen image, the following function information will appear for 3 seconds:
 - 🌟 = Mask menu (RT button)
 - i = Display change (BR button)
 - ☰ = Menu (TL button)
 - 🗑️ = Delete menu (BL button)
- Top right 🔍 and 🔄 for the functions of the two thumbwheels
- Bottom right 🔒 for button lock (if activated)
 - If the memory card or the selected file cannot be read, a corresponding icon appears in the right-hand margin of the black picture.

To activate additional information displays:

- ▶ Press the BR button
 - The displays are shown in sequence. Press the button repeatedly until the desired display appears.
 - Histogram and Clipping displays
 - Focus Peaking display (see p. 35)
 - Extended picture data
 - Back to standard view

Histogram and clipping displays

(For settings see p. 43)

- the histogram is displayed in the top left
- areas that are too light will flash red, while areas that are too dark will flash blue. The Clipping icon (🔴) appears additionally at the top right

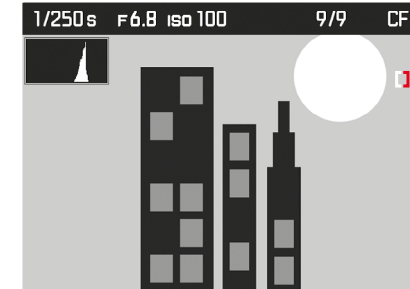

Notes

- The Histogram and the Clipping indicators are available when viewing both the entire picture and a section of it, but not when simultaneously viewing 4 or 9 thumbnails.
- The histogram and clipping displays always refer to the currently shown picture section.

Focus Peaking display

(For settings see p. 43, 35)

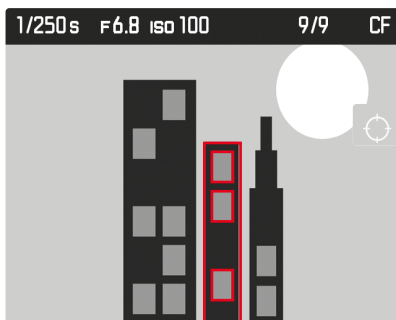
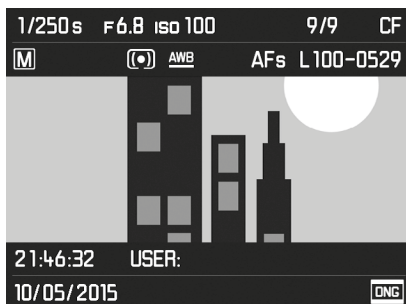
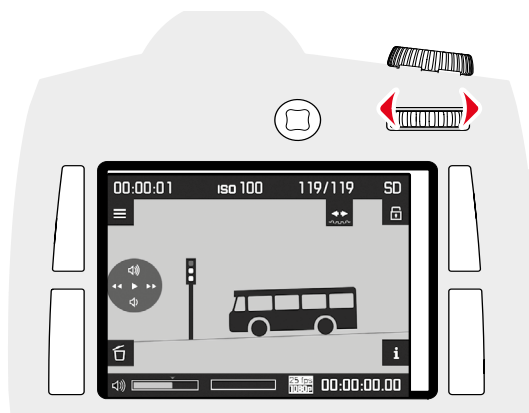
**Extended picture data****SELECTING/SCROLLING THROUGH RECORDINGS**

Use the thumbwheel to access other saved pictures. Once the first/last picture is viewed, the image series starts again in an endless loop accessible in both directions. The picture numbers change accordingly.

- ▶ Turn the thumbwheel
(to the left = lower numbers, to the right = higher numbers)

Note

This can be applied to all review methods and in any magnification level, including off-center cropped sections, and simultaneous viewing of multiple thumbnails.

CROPPED SECTION ZOOM

You can enlarge a cropped section of a picture anywhere in the frame for closer inspection. Magnifications up to 1:1 are available, i.e. 1 pixel of the picture renders up to 1 pixel on the display.

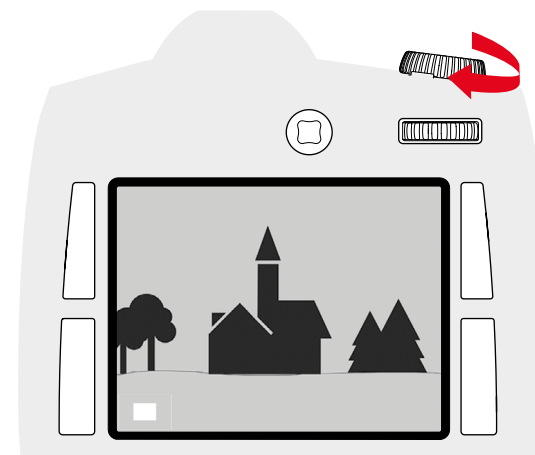
INCREMENTAL ENLARGEMENT

- ▶ Turn the Shutter speed setting wheel to the right
 - The further you turn the dial, the larger the magnification and the smaller the cropped section. Magnifications can be implemented in 4 increments until 1 pixel of the monitor depicts 1 pixel of the picture.
 - The rectangle within the frame in the bottom left corner represents the magnified section, as well as its position in the image.

MAX. ENLARGEMENT IN ONE STEP

- ▶ Pres and hold the thumbwheel (≥ 1 s)

Note

This function is available during automatic review, review for an unlimited time, and for any magnification level. If a cropped section was already selected beforehand, pressing the button for the first time will initially review the entire picture.

MOVING THE CROPPED SECTION

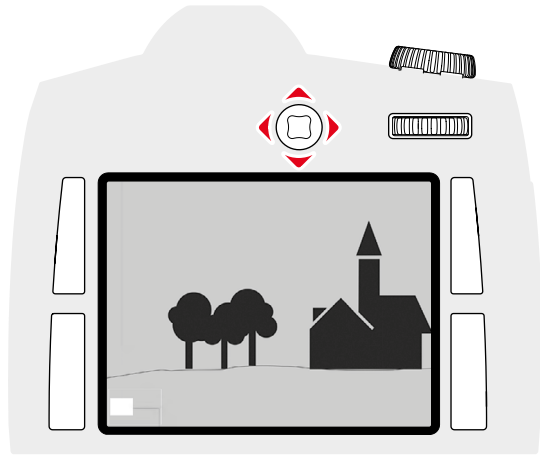

- ▶ Move the joystick in the relevant direction
 - The rectangle within the frame moves in the corresponding direction.

Note

The last cropped section that was used is saved when you exit review mode. When you want to return to Review mode the next time, you only have to press and hold the thumbwheel to view the section again. Pressing the dial again takes you back to the magnification level described above.

DISPLAYING MULTIPLE RECORDINGS AT ONCE

You can view up to 9 pictures at once to e.g. get an overview or to find a specific picture.

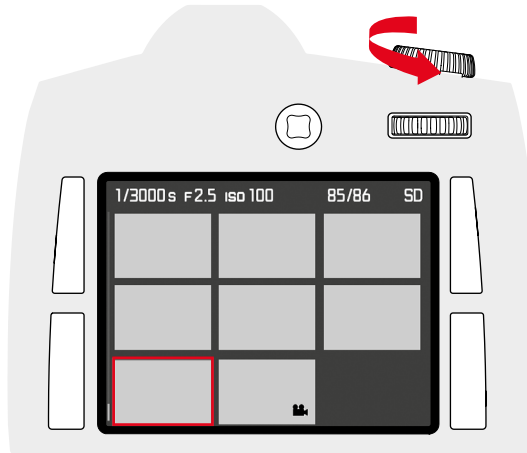

- ▶ Turn the shutter speed setting wheel to the left
 - 4 pictures are shown at the same time. Another turn on the thumbwheel increases the number of displayed recordings to 9.
 - When reviewing 4 or 9 pictures, the red frame indicates the picture that was previously displayed in full size.

To navigate between recordings:

- ▶ Press the joystick in the relevant direction
 - the currently viewed picture is framed in red and can be selected for a closer look.





To display the recording in full size:

- ▶ Turn the shutter speed dial to the right

MARKING/UNMARKING A RECORDING

Any picture can be marked to e.g. find it again quicker or to facilitate a simultaneous deletion of multiple pictures (see next section).

MARKING A RECORDING

- ▶ Press the TR/BR/TL/BL button
 - in the four corners of the screen image, the following function information will appear for 3 seconds:
 -  = Mask menu (TR button)
 -  = Display change (BR button)
 -  = Menu (TL button)
 -  = Delete menu (BL button)
- ▶ Select a recording
- ▶ Press the TR button
 - The recording is marked with .







Do exactly the same to remove marking.

UNMARKING A RECORDING

- ▶ Press the TR button
 - The  marking disappears.

DELETING A RECORDING

When reviewing a picture you have the option to delete it immediately. This can be useful, e.g. if the picture was already saved to other media, if you no longer want it or if you need to free up space on the memory card. You can optionally delete one, several or all recordings simultaneously (marked recordings cannot be deleted).

- ▶ Press the TR/BR/TL/BL button
 - in the four corners of the screen image, the following function information will appear for 3 seconds:
 -  = Mask menu (TR button)
 -  = Display change (BR button)
 -  = Menu (TL button)
 -  = Delete menu (BL button)
- ▶ Select a recording
- ▶ Press the BL button
 - in the four corners of the screen image, the following function information will appear:
 - ALL (TL button)
 -  (TR button)
 - OK (BR button)
 - SINGLE (BL button)
 - The  symbol for a marked picture, if applicable.

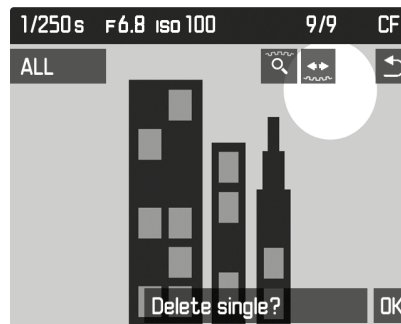

Deleting a single picture

- ▶ Press the BL button (SINGLE)
 - The next picture that has not been deleted is displayed. The following message appears if no other recordings are saved on the card: **No media file to display.**
- ▶ Press the BR button (OK)

Deleting multiple/all pictures

- ▶ Press the TL button (ALL)
 - To be certain, the following query screen is displayed on the monitor: **Delete ALL?**
- ▶ Press the BR button (OK)

Note:

Pressing the TR button () will return you to normal view.

OTHER FUNCTIONS

USER PROFILES

This camera allows the permanent storage of any menu settings, to e.g. access them quickly and easily for recurring conditions/image objects. For memory slots are provided to store custom settings, plus the factory setting, which is always available and cannot be modified. You can change the names of the saved profiles.

Any profiles configured for the camera can be saved to a memory card for use on other cameras. Similarly, profiles saved on a memory card can be transferred to the camera.

SAVE CURRENT SETTING AS USER PROFILE

Saving settings/Creating a profile

- ▶ Create custom settings for the desired functions via menu control
- ▶ Select **SETUP**
- ▶ Select **User Profiles** in the main menu
- ▶ Select **Save as User Profile** in the submenu
- ▶ Select a memory slot
- ▶ Confirm the selection

RENAMING PROFILES

- ▶ Select **SETUP**
- ▶ Select **User Profiles** in the main menu
- ▶ Select **Rename User Profile** in the submenu
- ▶ Select a profile
- ▶ Enter a name for the profile via the associated submenu keyboard and confirm your input (see p. 28)

APPLY/ACTIVATE PROFILES

- ▶ Select **SETUP**
- ▶ Select **User Profiles** in the main menu
 - The names of saved, active user profiles appear in white.
- ▶ Select **Load Profile** in the submenu
 - The **Standard Profile** is selected by default
 - The selected profile is marked as **active**.
 - Free memory slots appear in gray.

Note

— will appear in the original menu list instead of the name of the profile used if you change one of the settings for the profile currently in use.

EXPORTING/IMPORTING PROFILES TO/FROM THE MEMORY CARD

- ▶ Select **SETUP**
- ▶ Select **User Profiles** in the main menu
- ▶ Select **Import from Card** or **Export to Card** in the submenu
- ▶ Confirm the selection

Note

During profile imports/exports, all 4 memory slots are transferred to/from the memory card, including free slots. Any existing profiles stored in the camera will be overwritten/deleted during a profile import.

DATA MANAGEMENT

DATA STRUCTURE ON THE MEMORY CARD

FOLDER STRUCTURE

The files (= pictures) on the memory cards are saved in automatically generated folders. The first three characters signify the folder number (numerals), the last five the folder name (letters). You can change the numbers and the letters when you create a new folder. By default, the first folder is named "100LEICA", the second "101LEICA", etc. A folder will always be created with the next available number; you can have max. 999 folders.

FILE STRUCTURE

The file names in these folders consist of eleven characters. By default, the first file is named "L1000001.XXX", the second "L1000002.XXX", etc. "L" stands for the camera brand; you can change the next three characters at any time – numerals or letters can be used. The second group of numbers is the file number: "XXX" stands for the file format (DNG or JPG). If the folder currently in use contains file number 9999, then a new folder is created, in which the file numbering begins at 0001 again.

Notes

- When using memory cards that were not formatted with this camera, the file numbering will begin with 0001 again. Should the memory card already contain a file with a number higher than the last number assigned by the camera, then numbering will be continued from the relevantly highest number on that card.
- A relevant message will be displayed on the LCD panel once folder number 999 and file number 9999 are reached, and all numbering must be reset.

EDIT FILE NAMES

- ▶ Select **SETUP**
- ▶ Select **Image Numbering** in the main menu
- ▶ Select **Change Filename** in the submenu
 - A keyboard submenu is displayed.
 - The input line contains the full file name. The three white numerals in the first group can be changed.
- ▶ Delete the three selected characters
- ▶ Enter a new name of your choice (see p. 28)
- ▶ Confirm

Notes

- The change to a file name applies for all later pictures as well until a new change is made. The sequential number (second 4-digit group of numerals) will not be affected by the change; it can, however, be reset by creating a new folder (see previous page).
- When all user-affected changes are reset, then the file name will once again be "L100XXXX.XXX".
 - A keyboard submenu is displayed with the full file title in the title line. The three numbers in the first group are highlighted white and can be edited.

CREATING A NEW FOLDER

- ▶ Select **SETUP**
- ▶ Select **Image Numbering** in the main menu
- ▶ Select **New Folder** in the submenu
 - A keyboard submenu is displayed.
 - The input line contains the full folder name. The five white characters can be modified.
- ▶ Delete the five selected characters
- ▶ Enter a name of your choice
- ▶ Confirm
 - A prompt appears. Here you decide if you want the file numbers in the new folder to start at 0001 again (**Yes**) or if the numbering should continue (**No**).

Notes

- A file name change also applies to all subsequent folders or until another change is made.
- When all user-affected changes are reset, then the folder name will once again be "XXXLEICA".
- You can create a new folder at any time.

RESETTING IMAGE NUMBERING

- ▶ Select **SETUP**
- ▶ Select **Image Numbering** in the main menu
- ▶ Select **Reset Image Numbering** in the submenu
 - A relevant prompt is displayed.
- ▶ Confirm the creation of a new folder (**Yes**) or cancel the new folder (**No**).

Note

The name part of a new folder created using **Reset** remains unchanged. The file numbers in the folder will start again at 0001.

ADDING COPYRIGHT INFORMATION



This camera allows you to enter letters and other characters as a copyright mark for your picture files. You can enter up to 17 characters of information under 2 headings per picture.

- ▶ Select **SETUP**
- ▶ Select **Camera Information** in the main menu
- ▶ Select **Copyright Information** in the submenu
- ▶ Activate the **Copyright** function (**On**)
- ▶ Select **Information/Artist** in the submenu
 - A keyboard submenu is displayed.
- ▶ Enter the desired information (see p. 28)
- ▶ Confirm

RECORDING THE IMAGE LOCATION WITH GPS

The GPS (global positioning system) allows the pinpointing of a receiver anywhere in the world. When the function is activated the Leica S3 continuously receives the corresponding signals and updates the position data. It can write this information - latitude and longitude, height above sea level - to the "EXIF" data.

Please read the important information provided on the topic of GPS (see p. 4) before you activate this function

- ▶ Select **SETUP**
- ▶ Select **GPS** in the main menu
- ▶ Function activation (**On**) or deactivation (**Off**)
 - The "satellite" icon in the top display indicates the current status:
 -  most recent geolocation max. 6 min ago
 -  most recent geolocation max. 24 hrs ago
 -  no geolocation data available

FORMATTING A MEMORY CARD

Memory cards that have already been in use with this camera will usually not require formatting. An unformatted memory card that is inserted into the camera for the first time will have to be formatted. We recommend formatting memory cards from time to time, because residual data traces (data pertaining to individual pictures) may reduce the card's memory capacity.

- ▶ Select **SETUP**
- ▶ Select **Format Cards** in the main menu
- ▶ Select one of the cards in the submenu, or specify that you want to format both cards.
 - A corresponding query screen is displayed on the monitor to protect against unintentional deletion.
- ▶ Confirm the selection

Notes

- Never switch off the camera while data transfer is in progress.
- All data stored on a memory card will be lost during formatting. Formatting will not be prevented by the deletion protection set for individual pictures.
- Make it a habit to transfer all pictures to a safe storage location (e.g. the hard drive of your PC) at your earliest convenience.
- A simple formatting process will initially not irretrievably destroy existing data on the card. Only the directory will be deleted, which means the data will no longer be directly accessible. Data access can be restored with appropriate software. Only data subsequently overwritten when new data is saved will actually be irretrievable.
- Make sure to reformat the memory card in your camera if it was originally formatted in another device, e.g. a computer.
- Contact your retailer or Leica Customer Care if the memory card cannot be formatted/overwritten (see p. 72).

DATA TRANSFER

ABOUT USB

The Leica S3 is equipped with a USB 3.0 interface for transferring data to a computer. This enables data to be transferred quickly to computers with the same interface. The computer must either have a USB connection (to directly connect the Leica S3) or be equipped with a card reader for CF or SD/SDHC/SDXC cards. An up-to-date USB 3.0 driver must also be installed.

If the Leica S3 is connected to the computer with a LEMO® USB 3.0 cable, it is recognized by the operating system.

Notes

- Apple® Mac® computers only allow video files with a maximum file size of 4 GB to be transferred. An error message is issued if the video files are larger.
- Use only the LEMO® USB cable supplied.
- Do not disconnect the USB cable while a data transfer is running between the Leica S3 and the computer, as this could cause the computer and/or the camera to crash, and may even damage the memory card irreparably.
- The camera must not be turned off or automatically shut itself down due to a lack of battery power while data is being transferred from the Leica S3 to the computer, as this can cause the computer to crash. For the same reason, the battery must never be removed from the camera while the connection is active. Cancel the data transfer and switch off the camera (see p. 24) if the battery capacity drops significantly during data transmission. You will have to recharge the battery before proceeding (see p. 19).

USING RAW DATA (DNG)

You will need specific software for editing data in DNG format, e.g. the professional raw data converter Adobe® Photoshop® Lightroom®. It allows high-quality conversions of stored raw data. It furthermore provides quality-optimized algorithms for digital color processing, delivering exceptionally low-noise photographs with incredible resolution. During editing, you can adjust parameters like gradation, sharpness etc. in retrospect to achieve the best possible image quality.

RESETTING THE CAMERA TO FACTORY SETTINGS

This function allows you to reset all menu settings at once to restore the factory settings.

- ▶ Select **SETUP**
- ▶ Select **Reset Camera** in the main menu
- ▶ Confirm (**Yes**) or reject (**No**) the process

Note

This reset also affects any profiles configured and saved via **Save as User Profile** (see p. 58).

FIRMWARE UPDATES

Leica is continuously working on the further improvement and optimization of your camera. Since many camera functions are entirely controlled by software, some of these improvements and additions to the functional scope can be installed in retrospect. Leica offers firmware updates at irregular intervals, which you can download from our website.

Leica will notify you of any new updates, once you have registered your camera.

Find out which firmware version is currently installed:

- ▶ Select **SETUP**
- ▶ Select **Camera Information** in the main menu
- ▶ You will find the relevant version designation in the submenu **Camera Firmware**

More information about registering, firmware updates and how to download them to your camera, as well as any amendments and additions to this manual can be found in the customer area of our website at:

<https://owners.leica-camera.com>

EXECUTING A FIRMWARE UPDATE

You can simply download a new firmware from our homepage and transfer it to your camera:

- ▶ Format a memory card in your Leica S3
- ▶ Switching the camera off
- ▶ Insert the memory card into an integrated card reader, or one connected to your computer (a reader is required for firmware updates)
- ▶ Download the firmware file via the following link:
- ▶ Save the S-X_XXX.FW firmware file to the highest level of the card folder structure.
- ▶ Remove the memory card from your card reader.
- ▶ Insert the card into the camera
- ▶ Close the cover
- ▶ Switching the camera on
- ▶ Select **SETUP**
- ▶ Select **Camera Information** in the main menu
 - If the camera detects a more up-to-date firmware version than the existing one, this is indicated in the relevant line (**Camera** or **Lens**) with a character in front of and behind the firmware number.
- ▶ Select **Yes** to start the update process and **No** to cancel it
 - An intermediate screen is displayed during this process.
 - The update process starts. This can take several minutes.
 - After a successful update, a corresponding message is displayed for confirmation.

Notes

- Firmware updates may also contain updates for lenses. If this is the case, the lens firmware is updated automatically as soon as any of the relevant lenses, that do not have the latest firmware version, are connected.
- A corresponding warning is issued if the battery charge level is insufficient.

CARE/STORAGE

CAMERA HOUSING

- Keep your equipment meticulously clean, as any kind of dirt residue presents a breeding ground for micro organisms.
- Only clean the camera with a soft, dry cloth. Stubborn dirt should first be moistened with a watered-down detergent and can then be wiped away with a dry cloth.
- Wet a soft cloth with tap water, wring it out thoroughly and wipe the camera clean of any salt water spray. Then wipe it down thoroughly with a dry cloth.
- Wipe the camera with a clean, lint-free cloth to remove stains and fingerprints. Tougher dirt is hard to reach corners of the camera housing can be removed with a small brush. Take care not to touch the shutter blades.
- Store the camera in a closed and padded container to prevent friction damage and protect it against dust accumulation.
- Keep the camera in a dry, sufficiently ventilated place, where it will not be subjected to high temperatures and humidity. Make sure to remove all moisture from the camera if it was used in humid conditions.
- Do not store the camera in a leather case for extended periods of time to prevent fungal contamination.
- Empty your camera bag completely if it ever gets wet during use. Your equipment might otherwise be subjected to moisture and tanning residue released by the moist leather.
- All mechanical bearings and sliding surfaces on your camera are lubricated. Remember to press the shutter button several times every three months to prevent the lubrication points hardening if the camera will not be used for an extended period of time. We also recommend repeated adjustment and use of all the other operating elements.
- When using your camera in tropical climates, make sure to expose the equipment to sunlight and fresh air as much as possible to prevent fungal growth. Storage in airtight containers or cases is recommended only in conjunction with a desiccant like silica gel.

LENS

- A soft-bristle brush will usually suffice to remove dust from the outer lenses. Remove more severe soiling with a clean, soft cloth that is completely free of foreign matter. Wipe the lens in a circular motion from the center outward. We recommend using microfiber cloths that come in a protective container and are available from photography shops and other optical retailers. These cloths are machine-washable at 40°C. Do not use fabric softener and do not iron them. Never use spectacle lens cleaning cloths, as these are soaked in chemicals, which could damage the glass of the camera lenses.
- Attach a transparent UVA filter for optimal front lens protection in unfavorable conditions (e.g. sand, salt water spray). Please remember that the filter may create unwanted light reflections in some backlight situations and in case of high contrasts.
- The lens caps supplied protect the lens against accidental fingerprint smudges and rain.
- All mechanical bearings and sliding surfaces on your lens are lubricated. Make sure to periodically move the focus ring and the aperture setting ring to prevent seizing if the lens will not be used for an extended period of time.

VIEWFINDER/LCD PANEL

- Switch off your camera and leave it to stand at room temperature for around 1 hour if condensation has formed on or in the camera. The condensation will disappear, once the camera temperature has reached room temperature.

RECHARGEABLE BATTERY

- Remove the rechargeable battery if the camera will not be used for an extended period of time, as the date and time setting will be lost latest after 2 months.
- Lithium-ion rechargeable batteries should only be stored partially charged, i.e. not fully depleted or fully charged. The camera LCD panel will show the current charge level of the battery. Charge the battery twice a year for around 15 minutes to avoid deep discharge in case of very long storage periods.

MEMORY CARDS

- Make sure to store memory cards in their anti-static container when not in use.
- Do not store memory cards where they will be exposed to high temperatures, direct sunlight, magnetic fields or static electricity. Always remove the memory card if the camera will not be used for an extended period of time.
- We recommend formatting the memory card from time to time, because fragmented residual data from deleted files may block some of its storage capacity.

SENSOR

SENSOR CLEANING

- This function is only available if the battery has at least 50% charge. A warning will be displayed if that is not the case.
- Any inspection or cleaning of the sensor should be done in an environment that is as much as possible dust-free to prevent further contamination.
- Use clean, possibly ionized gases like air or nitrogen to blow loose dust from the cover glass of the sensor. We recommend using (rubber) bellows without a brush. Some specialist, low-pressure cleaning sprays, e.g. "Tetenal Antidust Professional" can also be used (follow the instructions provided for the product).
- An 8x or 10x magnifying glass is very helpful for the inspection before and after cleaning.
- Please contact Leica Customer Care if you are unable to remove the particles with the methods described above.
- A message will appear on the LCD panel, once the capacity of the rechargeable battery falls below 40% with the lens aperture fully open: **Please stop sensor cleaning immediately.** The shutter will automatically close when the camera is switched off.
- Make sure that the aperture is unobstructed and that nothing can prevent the shutter from closing correctly, as this would result in damage to the equipment!

Alternatively, send your camera to the Leica Customer Care department for sensor cleaning (see p. 70). This service is not part of the warranty offering and will therefore incur charges. Use the **Open Shutter** menu function if you feel confident that you can do the cleaning yourself. The function will keep the shutter open and allow access to the sensor.

- ▶ Select **SETUP**
- ▶ Select **Sensor Cleaning** in the main menu
- ▶ Confirm with **Yes**
 - The mirror folds up and the shutter opens.

Note

A warning message **Battery too low for sensor cleaning** will appear if the battery capacity is lower than required to indicate that the function is currently not available, and **Yes** cannot be selected.

- ▶ Clean the sensor
 - Make sure you follow the instructions below.
- ▶ Switch off the camera after you finish cleaning
 - The shutter will remain open for another 10 s for safety reasons.
 - A message appears on the display **Please stop sensor cleaning immediately.**

Important

- Leica Camera AG will not accept any responsibility for damages caused by the user when cleaning the sensor.
- Do not attempt to physically blow dust particles off the cover glass of the sensor. The smallest droplets of saliva can cause stains that will be difficult to remove.
- Do not use high pressure compressed air cleaners as they may also cause damage.
- Avoid touching the sensor surface with any hard objects during inspection and cleaning.

MENU OVERVIEW

		Page
 CAMERA	Drive Mode	28/38
	Focus Mode	34/35
	Exp. Metering	28/38
	Exp. Compensation	28
	Exp. Bracketing	42
	Mirror Up Mode	45
	Max. Flash Sync. Time	48

		Page
 IMAGE	ISO	28/36
	White Balance	37
	Photo File Format	32
	JPG Resolution	32
	Photo Settings	32/33
	Video Resolution	50
	Video Settings	50/51/25

		Page
 SETUP	Storage Backup (CF+SD)	33
	Format Cards	62
	Image Numbering	61
	Auto Review Screen Target	54
	Capture Assistants	35/36/44/45
	Copyright Information	61
	User Profiles	60/63
	Auto ISO Setup	36
	Flash Sync. Mode	48
	Keylock	39
	Customize Controls	29/34/39/41
	Display Brightness	31
	Acoustic Signals	31
	Auto Power Saving	25/30/39
	GPS	30/61
	Date & Time	30
	Language	30
	Reset Camera	63
Sensor Cleaning	65	
Camera Information	2	

INDEX

A

A (Aperture priority)	39
Accessory	2
Acoustic Signals.....	31
AE	38, 39, 41
AF.....	34, 41
AF/AE Lock.....	41
AfC.....	34
AF metering field.....	34
AFs.....	34
Aperture	25, 40
Aperture priority mode - A.....	39
Assist functions, manual focusing.....	35
Audio level.....	51
Autofocus	34
Auto ISO	36
Auxiliary display	43

B

Battery capacity.....	19
B (Long-term exposure).....	43
Bracketing	42
Brightness, LCD panel/EVF.....	31
Buffer memory.....	68
Bulb.....	43
Button assignment.....	29

C

Care	62
Carry strap	5, 18
Center-weighted metering	38
Central shutter.....	24
CF card.....	20, 33
Charger	5, 18
Charge status	19, 20
Charging the battery	19
Cleaning, sensor	63
Clipping	53
Color rendering.....	37
Color space	32, 50, 68
Color temperature.....	37
Contact	70
Contrast	32
Control, exposure.....	40

Control, flash	48
Control, menu.....	26
Control, white balance	36
Copyright information	59

D

Data transfer.....	60
Date, setting	30
Daylight saving time	30
Default setting	30
Deletion, recording.....	56
Depth-of-field preview button	25, 28, 43
Diopter adjustment	23
Direct access.....	28, 29
Display.....	12, 31, 53
Display, display	13, 14
Display, settings.....	31
Displays, in the top display	13
Displays, in the viewfinder	12
Displays, on the LCD panel.....	14
DNG	32, 60

E

Exposure.....	38
Exposure, automatic.....	40
Exposure compensation	42
Exposure, long-term	43
Exposure, manual.....	40
Exposure metering	38
Exposure, metering methods	50
Exposure, modes	50
Exposure, simulation	40
Eyepiece.....	23

F

Factory settings, reset.....	60
File format	32, 68
File name	59
File numbering.....	58
File size	68
Firmware	7
Firmware updates	61
Flash, control.....	48
Flash, exposure metering	47
Flash firing, continuous	49
Flash, HSS	48

Flash, linear	48
Flash, modes	48
Flash, range	48
Flash, strobescope.....	49
Flash, sync time	48
Flash unit, compatible	47
Focal plane shutter	24
Focusing.....	34, 50
Focusing screen.....	22
Focus peaking.....	35, 54
Formatting, memory card.....	60
Frame	45
Frame rate	50
Full matt screen	22
Function adjustments.....	29
Functions of the operating elements.....	24

G

GPS	59
Gray Card	37
Grid line.....	43

H

Histogram	43, 53
Horizon display	44
HSS	48

I

Image numbering	58
Image properties.....	32, 50
Individual button assignment.....	29
Info display	31
Information, general	6
Information, regulatory.....	3
Interval shooting	46
ISO	36, 50
ISO, automatic	36

J

JPG	32
JPG setting.....	32

L

Language	30
LCD panel.....	6, 62
Legal information	2

Leica Academy.....	70
Leica Customer Care.....	70
Lemo jack.....	47
Lens	4, 6, 62
Lenses, compatible	22
Level, audio.....	51
Light source.....	36
Linear flash mode	48
Live View	34, 40, 43
Long-term exposure.....	43

M

Magnification, MF assist function	35
Magnification, Playback/Review mode	54
Magnifying glass	35
Main menu.....	26
Main switch	24
Management, data	58
Manual exposure setting - M	40
Manual focusing.....	35
Memory card	5, 6, 20, 21, 33, 58, 60, 62
Menu language	30
Menu option	64
Menu screen.....	26
Metering memory lock	41
Metering methods, distance	34
Metering methods, exposure	38
MF.....	35, 41
Microphone	51
Mirror up mode.....	45
M (Manual exposure setting)	40
Mode shift	39
Monochrome	33
Monochrome photography	33
Multi-field metering	38

N

Name, file	59
Navigation, menu	27
Noise reduction	43
Notes, GPS	3
Notes, legal.....	2
Notes, on disposal	3
Notes, safety.....	4
Notes, WLAN	3

O		W	
Operating elements.....	24	Warning signal	31
Operating modes, exposure.....	50	Warranty.....	7
P		White balance	36
Parts, designation	10	Wind noise damping.....	51
P (automatic program).....	39	WLAN	3
Picture series.....	45		
Picture, series.....	45		
Picture series devices	69		
Playback/Review, automatic	52		
Playback/Review mode.....	52		
Power saving.....	30		
Power saving, automatic.....	30		
Preview.....	52		
Profiles, user.....	58		
Q			
Quick access	28		
R			
Range measurement	34		
Rating, recording.....	55		
Raw data.....	60		
Rechargeable battery	4, 6, 62		
Recording, delete	56		
Recording, interval	46		
Recording, Live View	34		
Recording, photo.....	30, 34		
Recordings, marking/rating	55		
Recording, video	50		
Registration	61		
Regulatory information	3		
Repair service	70		
Replacement parts.....	2		
Reset	60		
Resolution.....	32, 50		
S			
Safety remarks.....	4		
Saturation.....	33		
SD card	21, 33, 58		
Self-timer.....	46		
Sensor	6, 63		
Sensor, cleaning	63		
Serial exposures	45		
Settings, custom	58		
Settings, video	50–51		
Sharpness.....	32		
Short cut	29		
Shutter button.....	24		
Shutter release	24		
Shutter speed priority (T).....	40		
Shutter type.....	24		
Signal sounds	31		
Silent, recording.....	31		
S Lens	22		
Slow motion.....	52		
Sound recording	51		
Spot metering.....	38		
Standby mode.....	30		
Stereo.....	51		
Storage	62		
Submenu	26		
Switching off.....	24		
Switching on	24		
Sync point	48		
T			
Technical Data	68		
Thumbwheel	27		
Time	30		
Time, automatic (GPS).....	30		
Time code.....	50		
Time setting.....	30		
Time zone	30		
Transfer, data	60		
T (Shutter speed priority mode)	40		
TTL metering.....	47		
U			
Updates, firmware.....	61		
USB	60		
User profile	58		
V			
Video settings.....	50		
Viewfinder.....	62		
Volume	31, 51		

TECHNICAL DATA

Camera name

Leica S3

Camera type

Digital medium format SLR camera

Type no.

6847

Lens mount

Leica S bayonet with contact strip for communication between lens and camera

Lens system

Lens system Leica S lenses, compatible with several third-party medium format lenses via adapter

Picture format/Aspect ratio

30 x 45 mm/3:2

Picture sensor/Resolution

Leica CMOS sensor with 4.6 µm pixel size, with micro lenses, 64 MP

Low-pass filter

None (for maximum sharpness), suppression of moiré effects due to external digital image processing on the sensor

File formats

Photo: DNG (raw data), DNG + JPG, JPG

Resolution DNG: 64 MP, JPG: 64 MP, 24 MP, 4 MP

File size

DNG: approx. 70 MB, JPG: approx. 2-30 MB (depending on resolution used, image content and ISO level), video: up to 29 minutes of uninterrupted recording

Buffer memory

2 GB, maximum number of pictures in a series (depending on memory card used): DNG: max. 6, JPG: unlimited

Color spaces

Adobe® RGB, sRGB, ECI RGB 2.0

White balance

Automatic, manual via measurement, 8 presets, color temperature input

Storage medium

CF cards (max. UDMA 7), SD-/SDHC-/SDXC < 512 GB memory cards UHS-I (recommended), UHS-II, 4K video recordings can only be stored on SD cards (UHS-I).

Menu languages

English, German, French, Italian, Spanish, Russian, Japanese, Traditional Chinese, Simplified Chinese, Korean, Portuguese

Exposure control

Exposure metering

Open aperture measurement through the lens (TTL)

Metering methods

Spot (3.5%), center-weighted, multi-field metering (5 fields)

Metering memory lock

Pressing the pressure point on the shutter button saves 1 picture or continuously with the joystick

Exposure compensation

± 3 EV (exposure values), adjustable in half increments

Automatic bracketing

3 or 5 pictures, optionally 1/2 EV, 1 EV, 2 EV, 3 EV deviation between individual pictures, exposure can be changed through the aperture and/or shutter speed depending on the selected operating mode

Measuring range

(with 2.5 aperture and ISO 100), Spot metering: EV 2.7 - 20, Center-Weighted and Multi-Field metering: EV 1.2 - 20, warning in viewfinder if the measuring range of the measuring cell for the existing multi-field photo diode light is exceeded or falls below the range (continuous light measurements)

Sensitivity

ISO 100, ISO 200, ISO 400, ISO 800, ISO 1600, ISO 3200, ISO 6400, ISO 12500, ISO 25000, ISO 50000, automatic

Exposure modes

automatic program with program shift function

(**P**), aperture priority mode (**A**), shutter priority mode (**T**), manual setting (**M**)

Flash exposure control

Flash unit connectors

Accessory shoe with central and control contacts, LEMO® or standard flash jack without light output control

Synchronization

Flash sync time: $\frac{1}{125}$ s or $\frac{1}{1000}$ s for lenses with central shutter, slower shutter speeds can be used, optionally at the start or end of the exposure; Flash function with faster shutter speeds ($\frac{1}{180}$ s - $\frac{1}{4000}$ s) available with relevantly equipped flash units (HSS mode)

Flash measuring cell

Multi-field photo diode

Flash exposure metering/control

(with system-compatible Leica flash units attached to the camera)

Controlled by the flash unit with TTL pre-flash metering, including automatic transfer and consideration of the sensitivity and set/controlled lens, all of the exposure modes can be used, automatic adjustment of the flash light to the existing light

Linear flash mode

(with system-compatible, appropriately equipped Leica flash units, linear flash mode with TTL pre-flash metering and automatic TTL HSS control) For flash photography with shorter shutter speeds than the sync speed by firing several flashes in quick succession, automatic switch-over to HSS flash mode if the sync speed is not achieved

Stroboscope flash mode

(Taking pictures while recording video)

With exposure modes **P** and **A** including automatic adjustment of the exposure time with system-compatible, relevantly equipped Leica flash units

Flash exposure compensation

Setting option in relevantly equipped flash units

Displays in flash mode

Ready status indicated by flashing or constantly lit flash icon in the viewfinder

Focusing

Sharpness recognition

Phase detection process in Live View mode based on contrast

Sensor/metering field

A central cross-type sensor defined by cross hairs on the focusing screen; the metering field can be positioned freely in Live View mode

Flash modes

Optional AFs (single) = focus priority, AFc (continuous) = release priority, MF (manual), manual override of the automatic setting at any time

Metering memory lock

Pressing the pressure point on the shutter button saves 1 picture or continuously with the joystick

Autofocus drive

In lenses

Viewfinder system

Eyepiece

High eye point viewfinder, diopter correction adjustable from -3 to +1 dpt. on the viewfinder

Viewfinder

98%

Magnification

0.87 times with 70 mm lens, when set to infinity and 0 dpt.

Displays

Viewfinder

LCD line under viewfinder field, illuminated, displays

Top display

Self-illuminating LCD

LCD panel

3" color TFT LCD panel with 16 million colors and 921,600 pixels, approx. 100% image field, max. 170° viewing angle, anti-reflection/dirt-repellent glass (Corning® Gorilla Glas®), color space: sRGB

Live View mode

Optionally with/without lighting simulation, spot metering field can be moved within entire image field, also linked to freely movable AF metering field, display can optionally include histogram and clipping, marking of in focus subject parts (focus peaking), grid lines and level display, picture information

Video mode

Format, resolution, frame rate, color scanning

MOV (motion JPG), optional full HD (1080 x 1920 pixels) with 24, 25 or 30 fps or Cine 4K (4096 x 2160 pixels) with 24 fps, 4:2:2, the full sensor width is always used

Exposure control

Same as for photos

Sound recording

In 48 KHz/16 bit stereo, optionally with internal or external microphones, time code

Miscellaneous

Focus peaking, uncompressed Full HD (1080p) 8 bit 4:2:2 HDMI video stream for recordings using external HDMI recording devices

Shutter and shutter release

Shutter

Focal plane shutter in housing, in relevantly equipped Leica **CS** lenses a central shutter.

Shutter speeds

Manual setting (at **T** and **m**): 8 min - 1/4000 s in half increments (8 - 1/1000 s with central shutter).

Automatic setting (at **P** and **A**): stepless from 8 min to 1/4000 s (8 - 1/1000 s with central shutter)

Picture series/interval shooting

Serial exposures: approx. 3 fps

Interval shooting: Time to start

Number of pictures and interval can be selected

Shutter button

Two-stage: activation of the exposure and sharpness metering and metering memory lock - release

Self-timer

Optional delay of 2 or 12 s

Indicated by flashing LED on front of the camera and corresponding display on the LCD panel

Switching the camera on/off

Via main switch on camera top panel, optional automatic deactivation after approx. 2/5/10 minutes

Power supply (Leica BP-PRO 1)

Lithium-ion battery, rated voltage: 7.3 V, capacity: 2300 mAh, capacity indicated in top display

Charging voltage/current: DC 1250 mA/7.4 V

Manufacturer: PT. VARTA Microbattery Indonesia, Made in Indonesia
Permanent power supply available using mains power pack (optional accessory)

Charger (quick action charger S)

Model number: 9C94270

Inputs: Alternating current 100-240 V, 50/60 Hz, 200 mA with automatic switch-over

Output: Direct current 7.4 V rated, 1250 mA/max. 8.25 V, 1265 mA

Manufacturer: Ansmann, Made in China

GPS

Optional (not available everywhere due to country-specific legislation), data are written to EXIF header in picture files.

WLAN

802.11n standard, integrated in camera, camera and picture control via smartphone or tablet app

Level display

Accelerometer measurement, metering range: Lean (around the transverse axis) and tilt (around the longitudinal axis) by ± 90° in each case, metering accuracy/display sensitivity: ≤ 1° at 0-40°C, on-screen display

Camera housing

Material

Full metal housing: Magnesium die-cast with non-slip plastic cover

Top panel: magnesium

Base plate: aluminum

Bayonet: stainless steel

Tripod thread

A 1/4 (1/4") DIN and A 3/8 (3/8") DIN (steel inserts) each with twist lock in accordance with DIN 4503, in metal tripod plate, centered under the lens axis

Operating conditions

0 to +45°C, 15 - 80% humidity

Interfaces

ISO accessory shoe with additional control contacts and bores for locking pin, HDMI jack type C, LEMO® jack for data output (USB 3.0 standard), LEMO® jack for remote control accessory/flash remote control, audio output/input, available via audio adapter (optional accessory)

Dimensions (W x H x D)

approx. 160 x 120 x 80 mm

Weight

approx. 1260 g (incl. battery)

LEICA CUSTOMER CARE

Please contact the Customer Care department of Leica Camera AG for the maintenance of your Leica equipment and for help and advice regarding Leica products and how to order them. You can also contact the Customer Care department or the repair service provided by your regional Leica subsidiary for repairs or warranty claims.

Leica Camera AG

Leica Customer Care
Am Leitz-Park 5
35578 Wetzlar
Germany

Telephone: +49 6441 2080-189

Fax: +49 6441 2080-339

E-Mail: customer.care@leica-camera.com
www.leica-camera.com

LEICA ACADEMY

Have a look at our full seminar program with many interesting workshops on the topic of photography at:

us.leica-camera.com/Leica-Akademie/Global-Leica-Akademie

