

SC3100

"Auto Tracker"

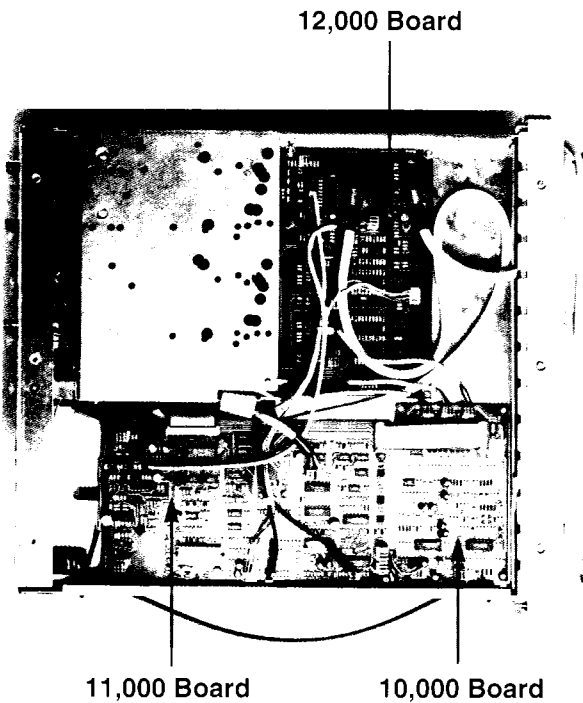
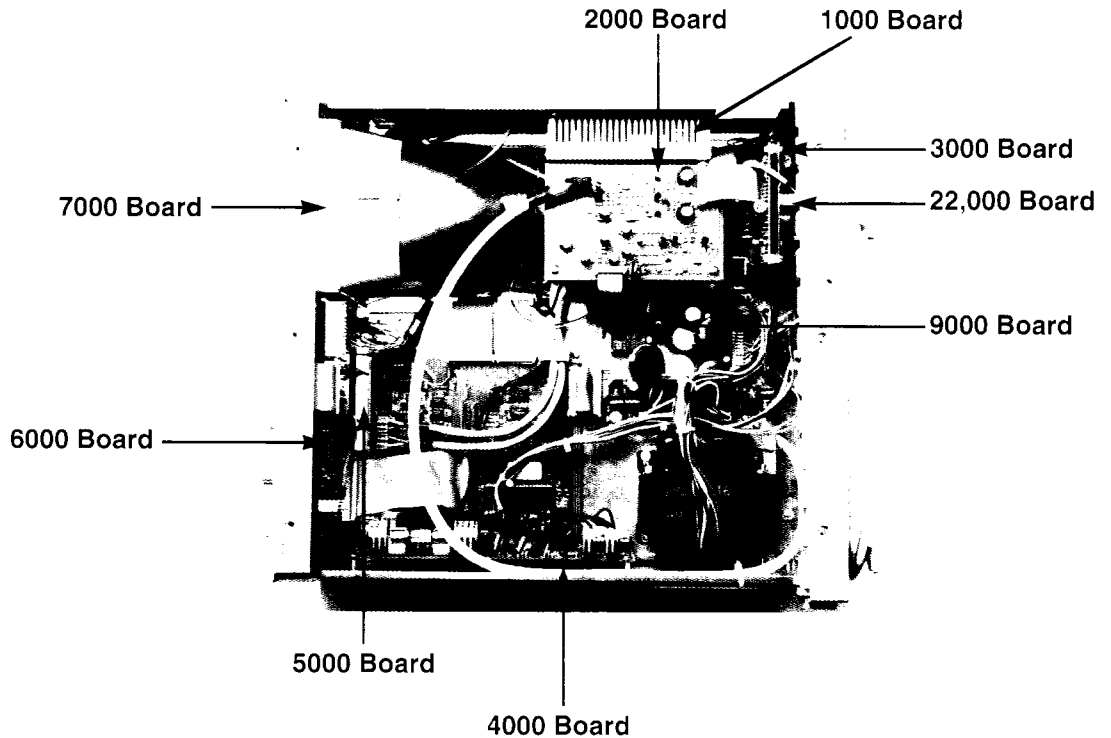

| Index | Page |
|--|-----------|
| SC3100 Block Diagram..... | 17-19 |
| 1000 High Voltage Board..... | 14,15 |
| 2000 YZ Preamp Board..... | 38-40 |
| 3000 YZ Board..... | 7,8 |
| 4000 DVM Board..... | 1-3 |
| 5000 Front Panel Board..... | 5,6 |
| 6000 Digital Select/Display Board..... | 36,37 |
| 7000 CRT Mode Board..... | 4 |
| 8000 Digital Board..... | 11-14 |
| 9000 Low Voltage Board..... | 9,10 |
| 10,000 Trigger/Input PP Board..... | 27,29 |
| 11,000 Sweep Board..... | 30-36 |
| 12,000 Attenuator Board..... | 16, 20-26 |
| 22,000 X-AMP Board..... | 41-43 |

This booklet contains schematic, board legend, and parts list for each board.

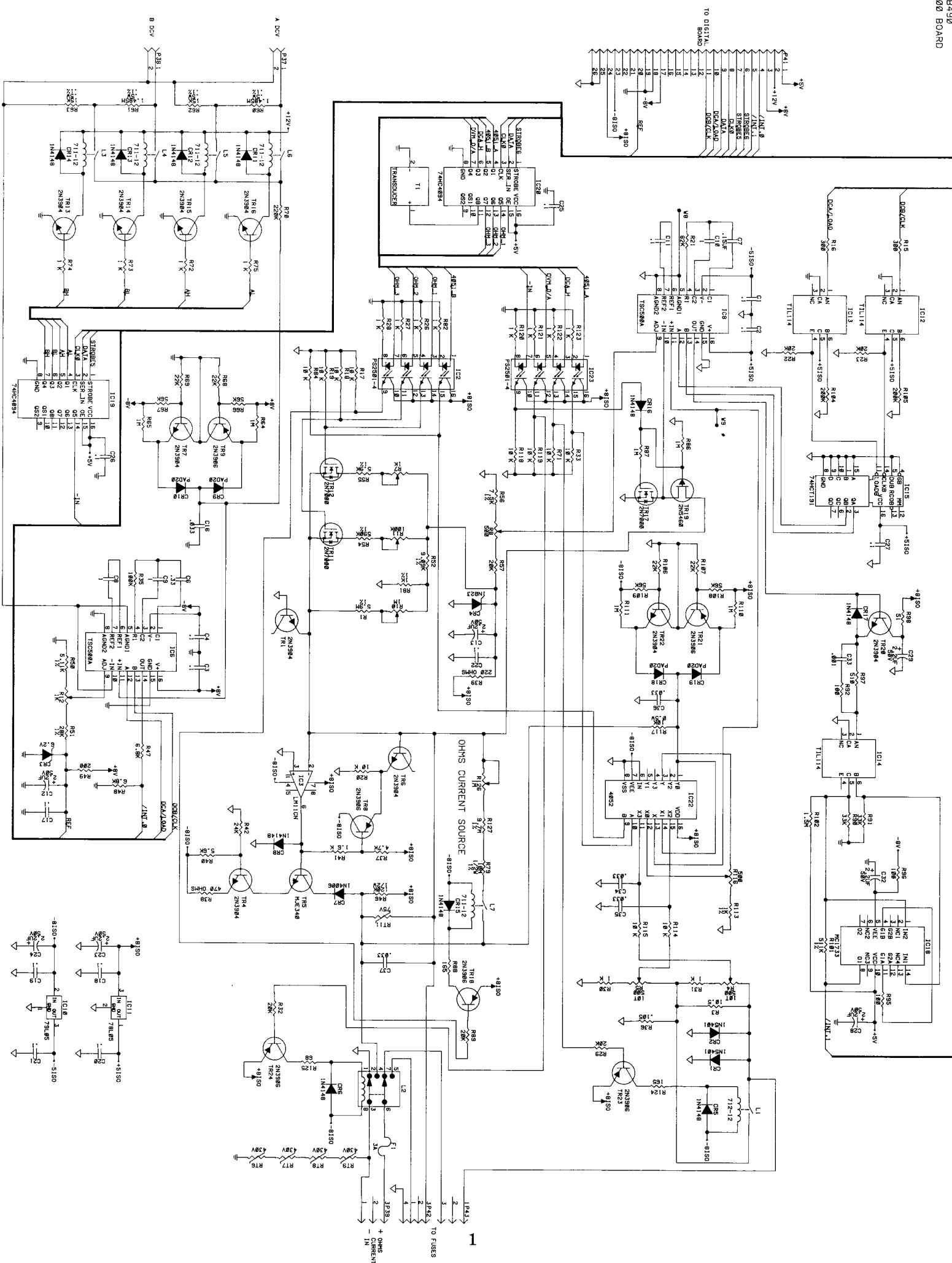

4000 DVM BOARD

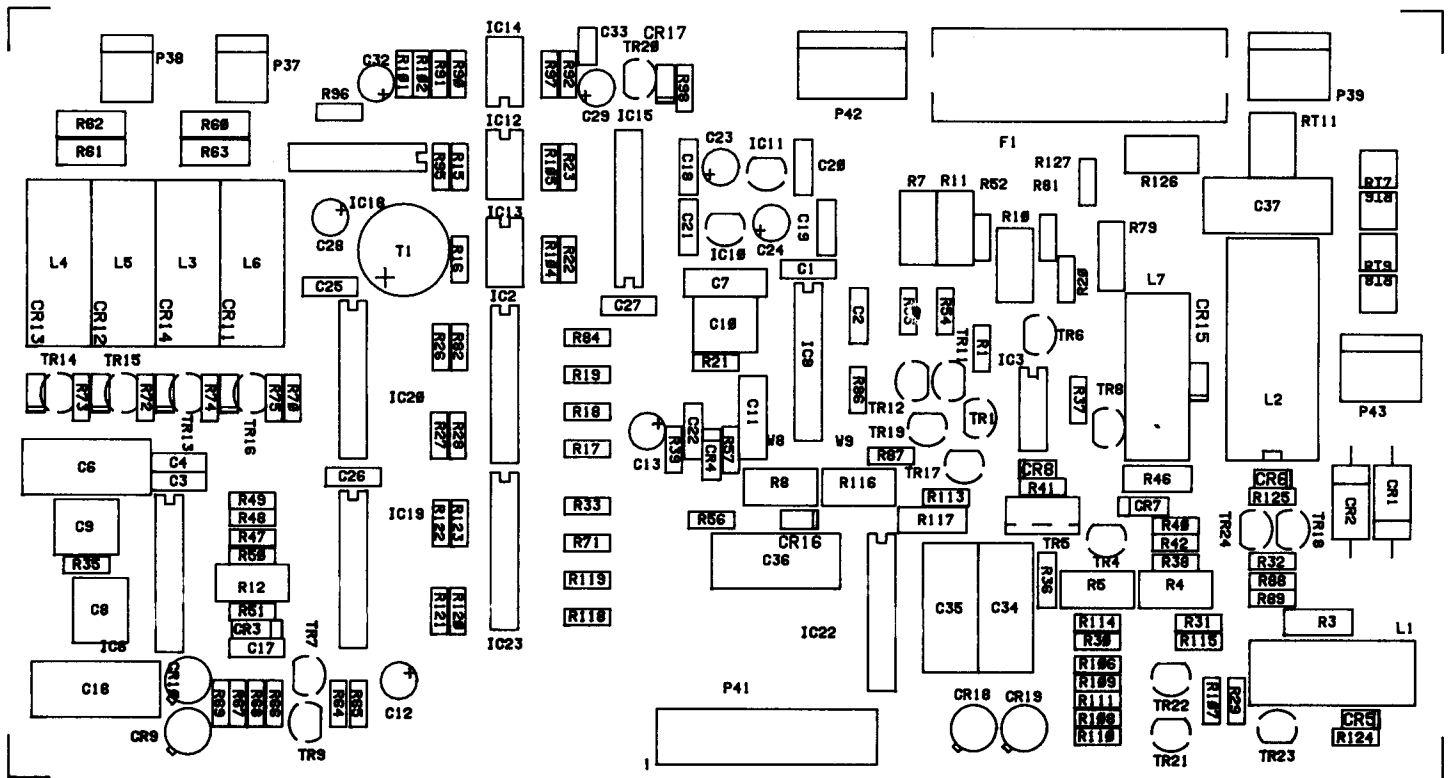

SCHEMATIC REFERENCE

PART NO.

DESCRIPTION

DVM (4000) BOARD

| | | |
|---------------|----------|---------------------------------|
| C1,2,18-22,27 | 24G104 | CAP,DISC.,.1UF,100V,80/-20%,Z5V |
| C3,4,17,25,26 | 24G104 | CAP,DISC.,.1UF,100V,80/-20%,Z5V |
| C6 | 24G471 | CAP,POLY.,.33UF,50V,5% |
| C7 | 24G674 | CAP,MET.POLY.,.15UF,100V,10% |
| C8,9 | 24G571 | CAP,STKD MET FILM,1UF,50V,5% |
| C10 | 24G571 | CAP,STKD MET FILM,1UF,50V,5% |
| C11 | 24G512 | CAP,MET.POLY.,.1uF,250V,10%,BUL |
| C12,28,32 | 24G384 | CAP,LYTIC,2.2UF,50V,20% |
| C13,23,24,29 | 24G384 | CAP,LYTIC,2.2UF,50V,20% |
| C16 | 24G404 | CAP,POLYPROP.,.033uF,200V,10% |
| C33 | 24G368 | CAP,DISC.,.001UF,100V,10% |
| C34,35,37 | 24G404 | CAP,POLYPROP.,.033uF,200V,10% |
| C36 | 24G404 | CAP,POLYPROP.,.033uF,200V,10% |
| CR1,2 | 16G14 | DIODE,PWR COMP,100V,3A,500uA, |
| CR3 | 50C12-1 | DIODE,ZENER,6.2V,7.5mA,5%,825 |
| CR4 | 50C12-1 | DIODE,ZENER,6.2V,7.5mA,5%,825 |
| CR5,6,8,15 | 50C5-2:A | DIODE,SIL,75V,100mA,.25uA,4148 |
| CR7 | 16G5 | DIODE,SILICON,800V,1A,10uA, |
| CR11-14 | 50C5-2:A | DIODE,SIL,75V,100mA,.25uA,4148 |
| CR16,17 | 50C5-2:A | DIODE,SIL,75V,100mA,.25uA,4148 |
| FL1 | 44G28 | FUSE,600V,3A |
| IC2,23 | 69G310 | IC,OPTOCOUPLER,PS2501 |
| IC3 | 69G730 | OP AMP,SINGLE,LO-OFFSET,LM11 |
| IC6 | 69G705 | IC,CONV,A/D,16PIN,TSC500ACPE |
| IC8 | 69G705 | IC,CONV,A/D,16PIN,TSC500ACPE |
| IC10 | 69G116 | IC,REG,-5V,100mA,79L05 |
| IC11 | 69G29 | IC,REG,+5V,100mA,78L05 |
| IC13-14 | 69G601 | IC,OPTO COUPLER,TIL-114 |
| IC15 | 69G675 | IC,COUNTER,UP/DWN,BIN,74HCT191 |
| IC18 | 69G117 | IC,AMP,DIFF,VIDEO,733 |

| SCHEMATIC REFERENCE | PART NO. | DESCRIPTION |
|-----------------------------------|--------------|--------------------------------|
| DVM (4000) BOARD CONTINUED | | |
| IC19,20 | 69G700 | IC,8BIT SHIFT REG,74HC4094 |
| IC22 | 69G183 | IC,MUX,,16PIN,CA4052,RCA |
| L1 | 41G39 | RELAY REED,712-12 |
| L2 | 41G34 | RELAY,PWR,5A 250V |
| L3-6 | 41G35 | RELAY,REED,711-12 |
| L7 | 41G35 | RELAY,REED,711-12 |
| R1 | 14A38-5906A | RES,MET.F,5.9M,1/4W,1%,100PPM |
| R3 | 14C29-1051A | RES,MET.F,10.5,1/2W,1%,100PPM |
| R4,5 | 15A36-2 | POT,VPC20T CERM,500,,10% |
| R7 | 15A36-1 | POT,VPC20T CERM,1K,,10% |
| R8,116 | 15A36-2 | POT,VPC20T CERM,500,,10% |
| R10,126 | 15A36-6 | POT,VPC 20T,CERM,1M,10% |
| R11 | 15G66-104 | POT,VPC,CERM,100K,10%,.5W,20T |
| R12 | 15A36-1 | POT,VPC20T CERM,1K,,10% |
| R15,16 | 14C1-301 | RES,CARBON,300,1/4W,5% |
| R17-19,33,71,84, 118,119 | 14C1-103 | RES,CARBON,10K,1/4W,5% |
| R20 | 14C1-103 | RES,CARBON,10K,1/4W,5% |
| R21 | 14C1-823 | RES,CARBON,82K,1/4W,5% |
| R22,23 | 14C1-203 | RES,CARBON,20K,1/4W,5% |
| R26-28,72-75,82 | 14C1-102 | RES,CARBON,1K,1/4W,5% |
| R29,32,89 | 14C1-203 | RES,CARBON,20K,1/4W,5% |
| R30,31,81,113 | 14A38-1003A | RES,MET.F,1K,1/4W,1%,100PPM |
| R35 | 14C1-104 | RES,CARBON,100K,1/4W,5% |
| R37 | 14C1-472 | RES,CARBON,4.7K,1/4W,5% |
| R38 | 14C1-471 | RES,CARBON,470,1/4W,5% |
| R39 | 14A38-2212A | RES,MET.F,221,1/4W,1%,100PPM |
| R40 | 14C1-562 | RES,CARBON,5.6K,1/4W,5% |
| R41 | 14A38-1603A | RES,MET.F,1.6K,1/4W,1%,100PPM |
| R42 | 14C1-243 | RES,CARBON,24K,1/4W,5% |
| R46 | 14C29-1215B | RES,MET.F,121K,1/2W,1%,50PPM |
| R47,48 | 14C1-682 | RES,CARBON,6.8K,1/4W,5% |
| R49 | 14C1-201 | RES,CARBON,200,1/4W,5% |
| R50 | 14A38-5113A | RES,MET.F,5.11K,1/4W,1%,100PPM |
| R51 | 14A38-2804A | RES,MET.F,28K,1/4W,1%,100PPM |
| R52 | 14A38-9093A | RES,MET.F,9.09K,1/4W,1%,100PPM |
| R54 | 14A38-5905A | RES,MET.F,590K,1/4W,1%,100PPM |
| R55 | 14A38-5903A | RES,MET.F,5.9K,1/4W,1%,100PPM |
| R56 | 14A38-7503A | RES,MET.F,7.5K,1/4W,1%,100PPM |
| R57 | 14A38-2004A | RES,MET.F,20K,1/4W,1%,100PPM |
| R60,61 | 14C26-14856A | RES,MET.F,1.485M,1/2W,1%,100P |
| R64,65 | 14C1-105 | RES,CARBON,1M,1/4W,5% |
| R66,67 | 14C1-563 | RES,CARBON,56K,1/4W,5% |
| R68,69 | 14C1-223 | RES,CARBON,22K,1/4W,5% |
| R70 | 14C1-224 | RES,CARBON,220K,1/4W,5% |
| R79 | 14C26-1007A | RES,MET.F,10M,1/2W,1%,100PPM |
| R86,87 | 14C1-105 | RES,CARBON,1M,1/4W,5% |
| R88,124 | 14Z1-161 | RES,CARBON,160,1/4W,5% |
| R90,91 | 14C1-333 | RES,CARBON,33K,1/4W,5% |
| R92 | 14C1-101 | RES,CARBON,100,1/4W,5% |
| R95,96 | 14C1-101 | RES,CARBON,100,1/4W,5% |
| R97 | 14C1-511 | RES,CARBON,510,1/4W,5% |
| R98 | 14C1-510 | RES,CARBON,51,1/4W,5% |
| R101 | 14C1-514 | RES,CARBON,510K,1/4W,5% |
| R102 | 14C1-155 | RES,CARBON,1.5M,1/4W,5% |
| R104,105 | 14C1-204 | RES,CARBON,200K,1/4W,5% |
| R106,107 | 14C1-223 | RES,CARBON,22K,1/4W,5% |
| R108,109 | 14C1-563 | RES,CARBON,56K,1/4W,5% |
| R110,111 | 14C1-105 | RES,CARBON,1M,1/4W,5% |
| R114,115 | 14C1-103 | RES,CARBON,10K,1/4W,5% |
| R117 | 14C29-1004A | RES,MET.F,10K,1/2W,1%,100PPM |
| R120-123 | 14C1-102 | RES,CARBON,1K,1/4W,5% |
| R125 | 14C1-680 | RES,CARBON,68,1/4W,5% |
| R127 | 14A38-9706A | RES,MET.F,9.7M,1/4W,1%,100PPM |
| RT6-9 | 33G260 | VARISTOR,430V,10% |
| RT11 | 33G246 | SURGE ARRESTOR,GAS DISCHG |
| T1 | 48G10 | TRANSDUCER, 2.3KHZ, 5VDC |
| TR1,4,6,22 | 19A33-1 | TRANS,NPN,40V,200mA,2N3904 |
| TR5 | 19G139 | TRANS,NPN,300V,.5A,MJE340 |
| TR7,13-16 | 19A33-1 | TRANS,NPN,40V,200mA,2N3904 |
| TR8,18,21,23,24 | 19A34-1 | TRANS,PNP,40V,200mA,,2N3906 |
| TR9 | 19A34-1 | TRANS,PNP,40V,200mA,,2N3906 |
| TR11,12,17 | 19G70 | TRANS,N-CHNL,60V,200mA,2N7000 |
| TR19 | 19A41 | TRANS,P-CHNL,40V,10mA,,2N5460 |
| TR20 | 19A33-1 | TRANS,NPN,40V,200mA,2N3904 |

CRT MODE
43A463
7000 BOARD

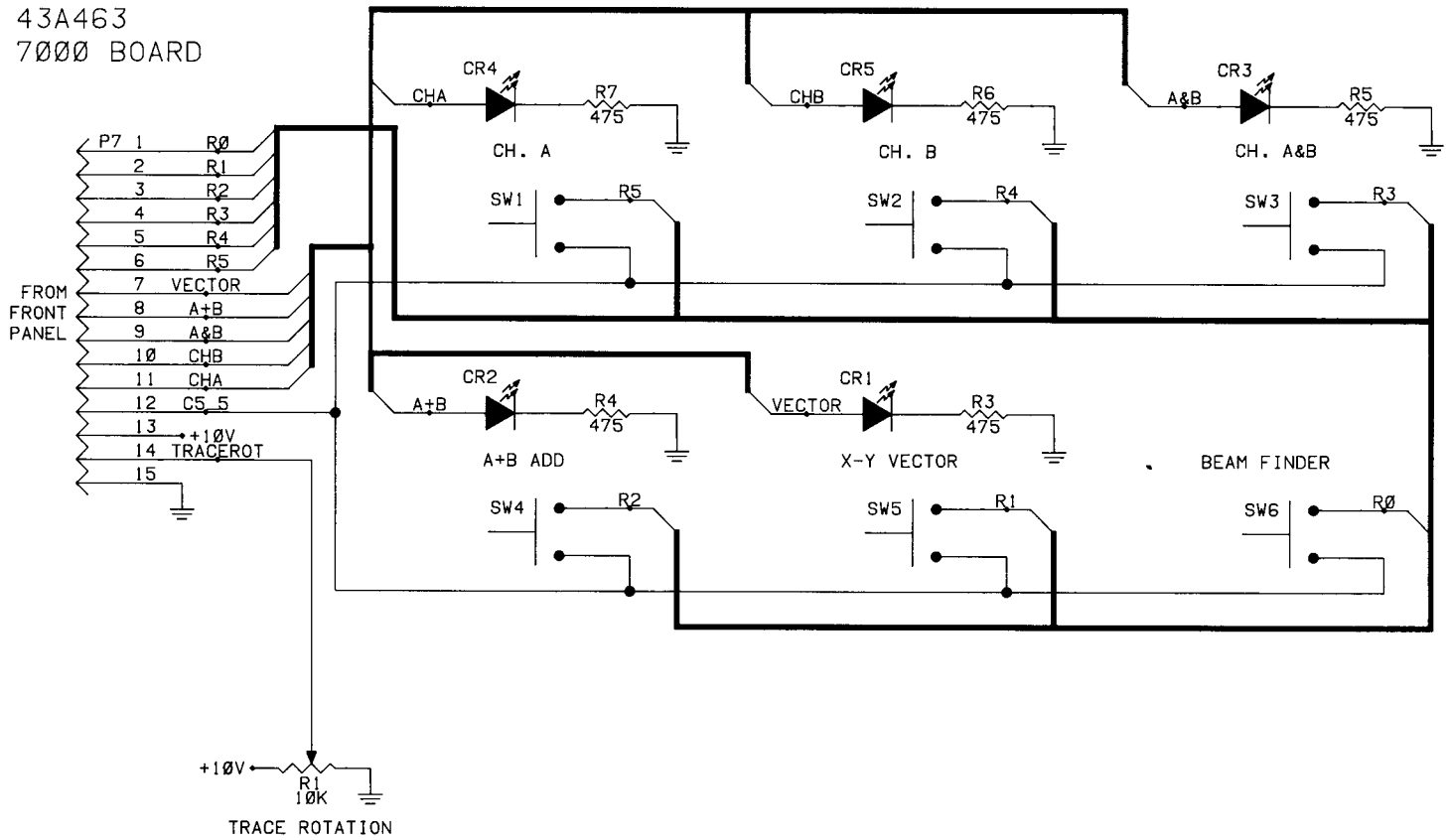

7000 CRT MODE BOARD

H2

H1

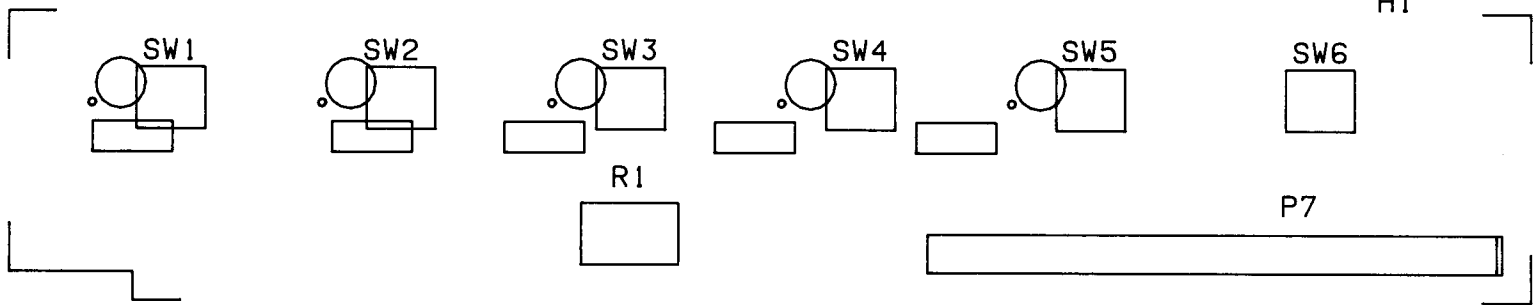

**SCHEMATIC
REFERENCE**

PART NO.

DESCRIPTION

CRT MODE (7000) BOARD

CR1-5
R3-7
SW1-6

20G37
14G102-4752A
25B417-2

SMTLED,RED,2.2V,10MA
RES,CHIP,475,1/8W,1%,100PPM
SWITCH PAD, CRT MODE

5000 FRONT PANEL BOARD

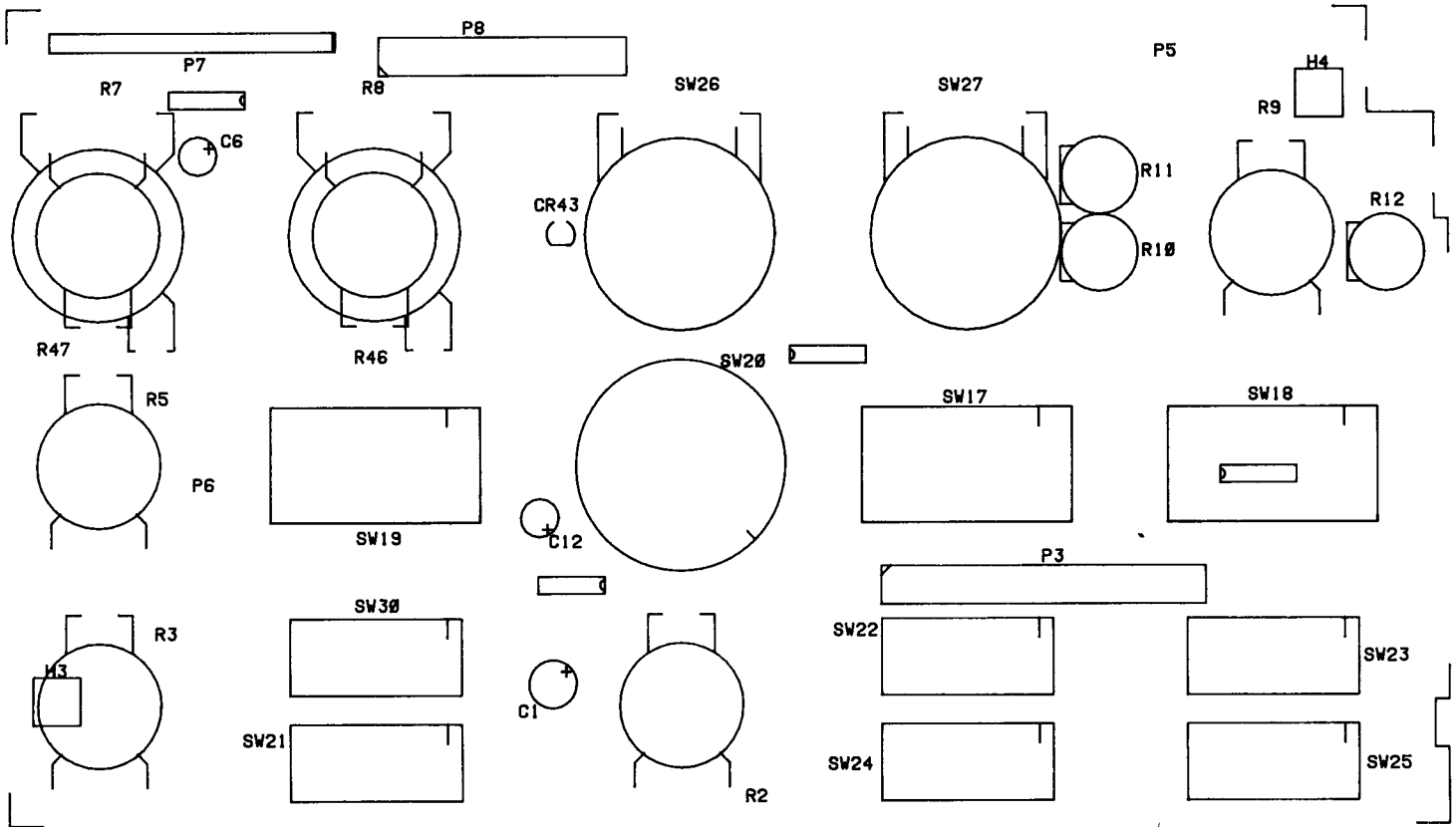

SCHEMATIC REFERENCE

PART NO.

DESCRIPTION

FRONT PANEL (5000) BOARD

| SCHEMATIC REFERENCE | PART NO. | DESCRIPTION |
|----------------------|--------------|--------------------------------|
| C1 | 24G407 | CAP,RLYTIC,47UF,25V,+/-20% |
| C2 | 24G618 | CAP,CHIP,.022UF,50V,10%,X7R |
| C3 | 24G465 | CAP,CHIP,.01uF,50V,10%,X7R |
| C4,5,19 | 24G612 | CAP,CHIP,100PF,50V,5%,NPO |
| C6,12 | 24G382 | CAP,RLYTIC,10UF,16V,20% |
| C9,13,16-18 | 24G575 | CAP,CHIP,.1UF,50V,10%,X7R |
| C14,15 | 24G606 | CAP,CHIP,.001UF,50V,10%,X7R |
| CR1,2,21-41,44,45-47 | 50G36 | SMT DIODE,SIL,75V,100MA,4148 |
| CR43 | 20G14 | LAMP,LED,2V,10mA,,MV5054-1 |
| IC1 | 69G529 | SMTIC,SWITCH,JFET,74HC4066 |
| IC2 | 69G474 | SMTIC,COUNTER,DECADE,74HC4017 |
| IC3 | 69G693 | SMTIC,8 BIT SHIFT REG,74HC4094 |
| IC4 | 69G445 | SMTIC,SH REG,PAR/SER,74HC165 |
| R2,3,5,9 | 15B47 | POT,PCMT,10K,EXTENDED LEGS |
| R10-12 | 15C26-24 | POT,MHPC CERM,10K,1/2W,20% |
| R31 | 14G102-4752A | RES,CHIP,475,1/8W,1%,100PPM |
| R32 | 14G102-9093A | RES,CHIP,9.09K,1/8W,1%,100PPM |
| R33 | 14G102-5623A | RES,CHIP,5.62K,1/8W,1%,100PPM |
| R34 | 14G102-1744A | RES,CHIP,17.4K,1/8W,1%,100PPM |
| R35 | 14G102-5113A | RES,CHIP,5.11K,1/8W,1%,100PPM |
| R36,37,44,45,59-69 | 14G102-1003A | RES,CHIP,1K,1/8W,1%,100PPM |
| R38,39 | 14G102-5112A | RES,CHIP,511,1/8W,1%,100PPM |
| R40,51-58 | 14G102-1005A | RES,CHIP,100K,1/8W,1%,100PPM |
| R41,48 | 14G102-5110A | RES,CHIP,5.11,1/8W,1%,100PPM |
| R46,47 | 15B52 | POT,VPC,CERM,10K,MULTI-TURN |
| R49,50 | 14G102-1004A | RES,CHIP,10K,1/8W,1%,100PPM |
| SW17,18 | 25B441 | SWITCH,BCD W/POT,14 POS |
| SW19 | 25B443 | SWITCH,BCD W/POT,24 POS |
| SW20 | 25G358 | SWITCH,ROTARY,1 POLE;12 POS. |
| SW21-23 | 25B421 | SWITCH,TOGGLE,2P2T |
| SW24,25,30 | 25B420 | SWITCH,TOGGLE,2P3T |
| SW26,27 | 15B46 | POT,VPC CARB,10K,1/2W,20%,PUSH |
| | 25G424 | SWITCH,POWER,PUSH-PUSH |

YZ AMPLIFIER
43B453
3000 BOARD

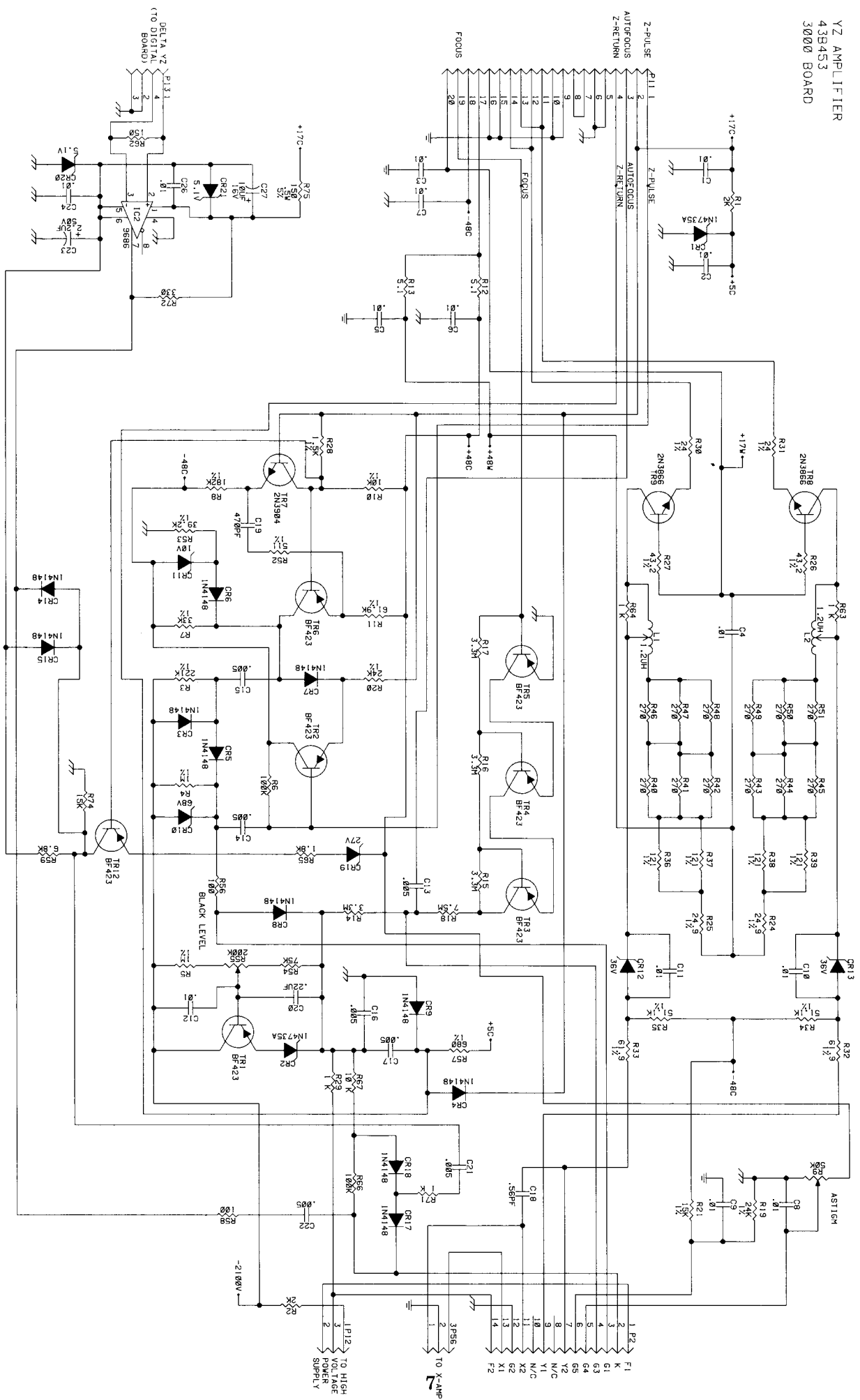

3000 YZ BOARD

SCHEMATIC REFERENCE

PART NO.

DESCRIPTION

YZ (3000) BOARD

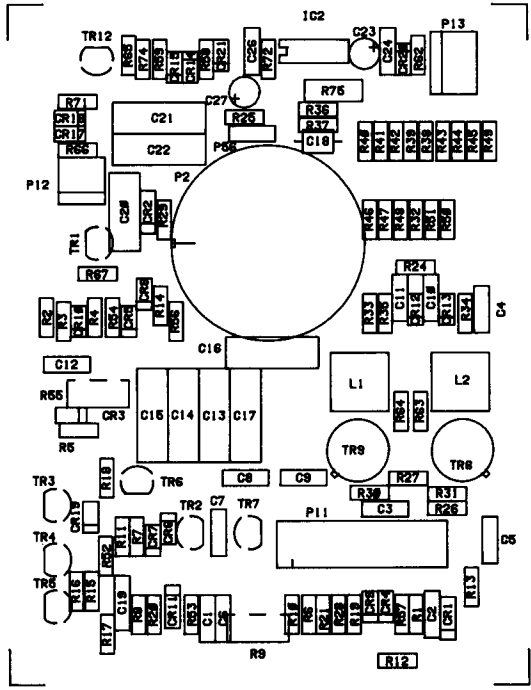

| | | |
|----------------|-------------|--------------------------------|
| C1-3,5-9 | 24G483 | CAP,MYLAR,.01UF,50V,5%,5MM |
| C4,10-12,24,26 | 24G483 | CAP,MYLAR,.01UF,50V,5%,5MM |
| C13-17 | 24G305 | CAP,DISC,.005UF,3000V,20% |
| C18 | 24G322 | CAP,DISC,.56PF,500V,10% |
| C19 | 24G119 | CAP,DISC,470PF,500V,10% |
| C20 | 24G168 | CAP,MYLAR,.22UF,100V,10% |
| C22,21 | 24G305 | CAP,DISC,.005UF,3000V,20% |
| C23 | 24G384 | CAP,LYTIC,2.2UF,50V,20% |
| C27 | 24G382 | CAP,LYTIC,10UF,16V,20% |
| CR1 | 50C4-6:A | DIODE,ZENER,6.2V,100mA,5%,4735 |
| CR2 | 50C4-6:A | DIODE,ZENER,6.2V,100mA,5%,4735 |
| CR3-9 | 50C5-2:A | DIODE,SIL,75V,100mA,.25uA,4148 |
| CR10 | 50C4-9 | DIODE,ZENER,68V,14mA,5% |
| CR11 | 50C4-12 | DIODE,ZENER,10V,95mA,10%,4740 |
| CR12,13 | 50C4-10 | DIODE,ZENER,36V,30mA,10%,4753 |
| CR17,18,15,14 | 50C5-2:A | DIODE,SIL,75V,100mA,.25uA,4148 |
| CR19 | 50C4-33 | DIODE,ZENER,27V,1W,5%,4750 |
| CR20,21 | 50C4-29 | DIODE,ZENER,1N4733A,5.1V,5% |
| IC2 | 69G674 | IC,HI SPD,TTL,COMPARATOR,9686 |
| L1,2 | 28A132 | CRT PEAKING COIL |
| R1 | 14C1-202 | RES,CARBON,2K,1/4W,5% |
| R2 | 14C1-202 | RES,CARBON,2K,1/4W,5% |
| R3 | 14A38-2215A | RES,MET.F,221K,1/4W,1%,100PPM |
| R4,5 | 14A38-1006A | RES,MET.F,1M,1/4W,1%,100PPM |
| R6 | 14C1-104 | RES,CARBON,100K,1/4W,5% |
| R7 | 14A38-3304A | RES,MET.F,33K,1/4W,1%,100PPM |
| R8 | 14A38-1825A | RES,MET.F,182K,1/4W,1%,100PPM |
| R9 | 15C26-9 | POT,MVPC CERM,50K,1/2W,20% |
| R10 | 14A38-1004A | RES,MET.F,10K,1/4W,1%,100PPM |
| R11 | 14A38-6194A | RES,MET.F,61.9K,1/4W,1%,100PPM |
| R12,13 | 14C1-51 | RES,CARBON,5.1,1/4W,5% |
| R14 | 14C1-335 | RES,CARBON,3.3M,1/4W,5% |
| R16-17 | 14C1-335 | RES,CARBON,3.3M,1/4W,5% |
| R18 | 14C1-755 | RES,CARBON,7.5M,1/4W,5% |
| R19,20 | 14A38-2404A | RES,MET.F,24K,1/4W,1%,100PPM |
| R21 | 14A38-1504A | RES,MET.F,15K,1/4W,1%,100PPM |
| R25,24 | 14A38-2491A | RES,MET.F,24.9,1/4W,1%,100PPM |
| R26,27 | 14C1-430 | RES,CARBON,43,1/4W,5% |
| R28 | 14A38-1503A | RES,MET.F,1.5K,1/4W,1%,100PPM |
| R29,71 | 14C1-102 | RES,CARBON,1K,1/4W,5% |
| R30,31 | 14C1-240 | RES,CARBON,24,1/4W,5% |
| R32,33 | 14A38-6191A | RES,MET.F,61.9,1/4W,1%,100PPM |
| R34,35 | 14A38-5114A | RES,MET.F,51.1K,1/4W,1%,100PPM |
| R36-39 | 14A38-1212A | RES,MET.F,121,1/4W,1%,100PPM |
| R40-50 | 14A38-2702A | RES,MET.F,270,1/4W,1%,100PPM |
| R52 | 14A38-5112A | RES,MET.F,511,1/4W,1%,100PPM |
| R53 | 14A38-3924A | RES,MET.F,39.2K,1/4W,1%,100PPM |
| R54 | 14C1-753 | RES,CARBON,75K,1/4W,5% |
| R55 | 15C26-11 | POT,MVPC CERM,200K,1/2W,20% |
| R56,58 | 14C1-101 | RES,CARBON,100,1/4W,5% |
| R57 | 14C1-681 | RES,CARBON,680,1/4W,5% |
| R59 | 14C1-682 | RES,CARBON,6.8K,1/4W,5% |
| R62 | 14C1-151 | RES,CARBON,150,1/4W,5% |
| R63,64 | 14C1-102 | RES,CARBON,1K,1/4W,5% |
| R65 | 14C1-182 | RES,CARBON,1.8K,1/4W,5% |
| R66 | 14C1-104 | RES,CARBON,100K,1/4W,5% |
| R67 | 14C1-103 | RES,CARBON,10K,1/4W,5% |
| R72 | 14C1-331 | RES,CARBON,330,1/4W,5% |
| R74 | 14C1-153 | RES,CARBON,15K,1/4W,5% |
| R75 | 14C4-151 | RES,CARBON,150,1/2W,5% |
| TR1,12 | 19G101 | TRANS,PNP,50MA,BF423 |
| TR2-6 | 19G101 | TRANS,PNP,50MA,BF423 |
| TR7 | 19A33-1 | TRANS,NPN,40V,200mA,2N3904 |
| TR8,9 | 19A13-1 | TRANS,NPN,30V,400mA,,2N3866 |

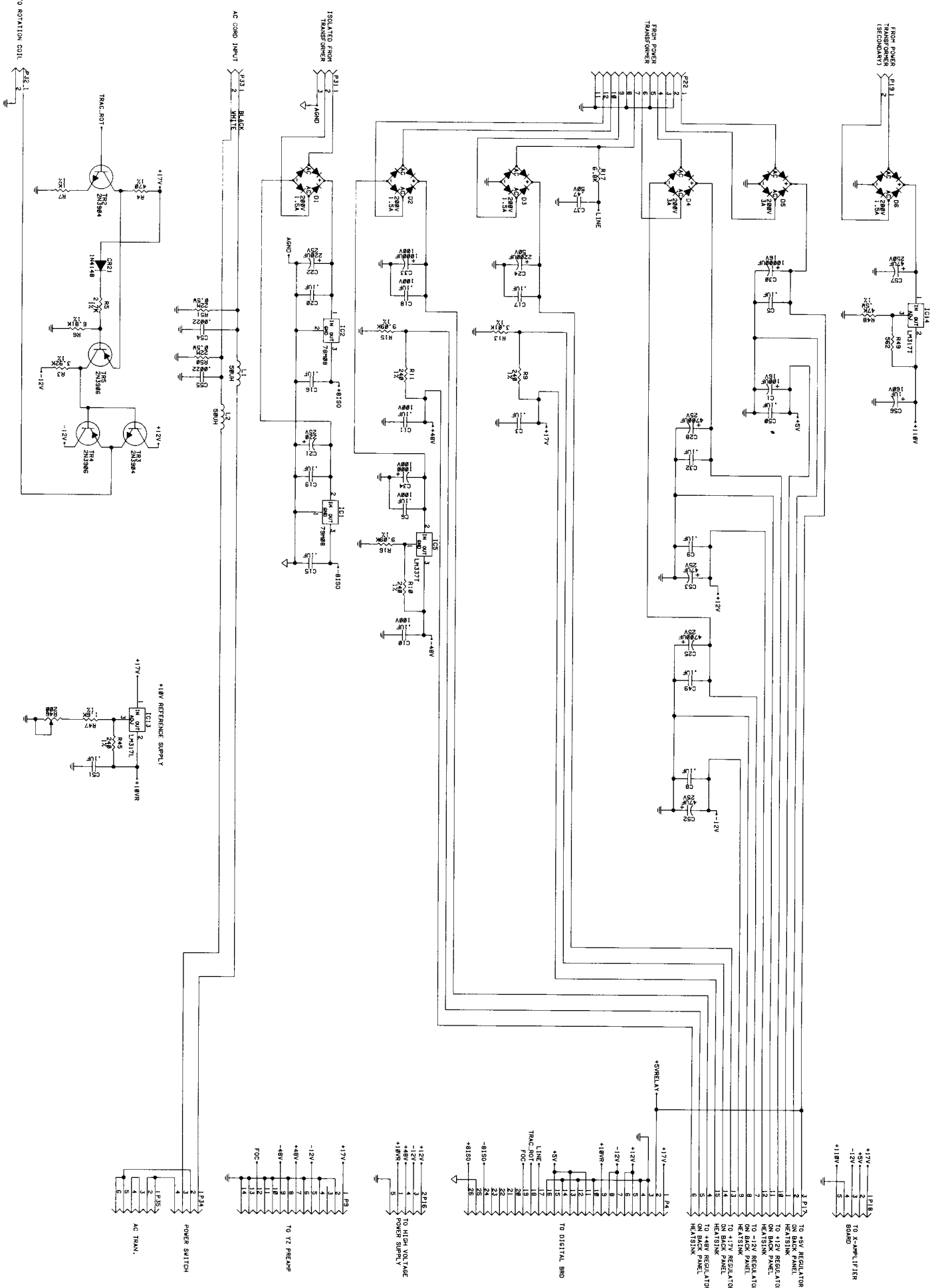

9000 LOW VOLTAGE BOARD

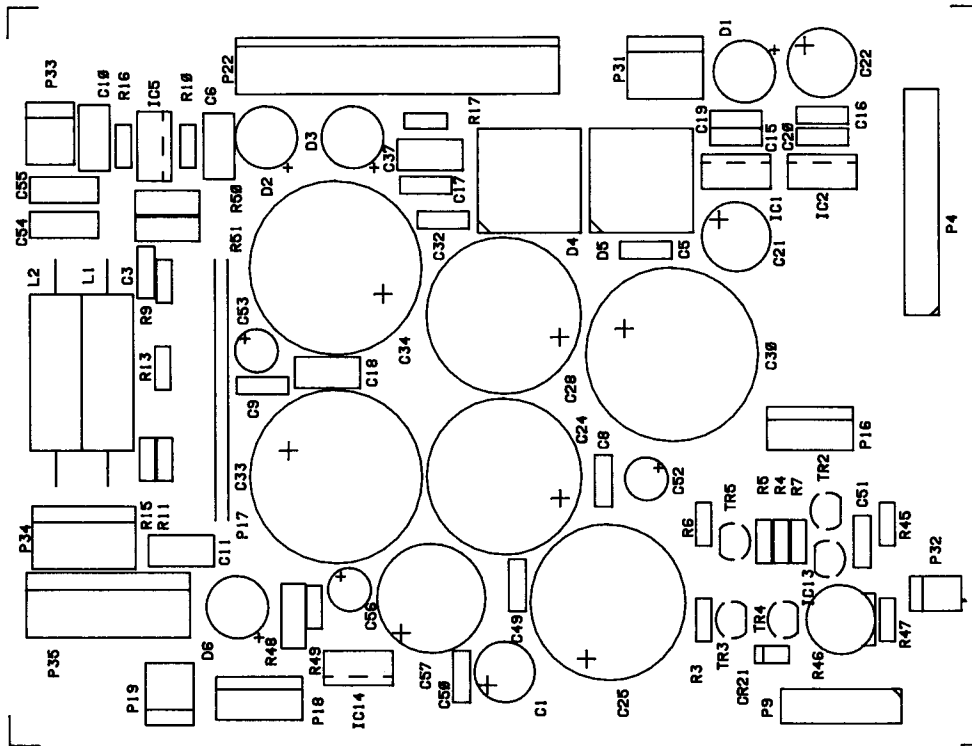

**SCHEMATIC
REFERENCE**

PART NO.

DESCRIPTION

LOW VOLTAGE POWER SUPPLY (9000) BOARD

| | | |
|--------------------------------|-------------|-------------------------------------|
| C1 | 24G442 | CAP, RLYTIC, 100UF, 16V, +/-20% |
| C3, 5, 8, 9, 17, 32, 49, 50 | 24G482 | CAP, MYLAR, .1UF, 50V, 5%, 5MM |
| C11, 10, 6, 18 | 24G216 | CAP, MYLAR, .1UF, 100V, 10% |
| C15, 16, 19, 20, 51 | 24G482 | CAP, MYLAR, .1UF, 50V, 5%, 5MM |
| C21, 22 | 24G410 | CAP, RLYTIC, 220UF, 25V, +/-20% |
| C24 | 24G672 | CAP, RLYTIC, 2200UF, 50V, +/-20% |
| C25, 28 | 24G635 | CAP, RLYTIC, 4700UF, 25V, +100/-20 |
| C30 | 24G413 | CAP, RLYTIC, 10000UF, 16V, +30/-10 |
| C33, 34 | 24G422 | CAP, RLYTIC, 1000UF, 100V, +30/-10 |
| C37 | 24G496 | CAP, MYLAR, .47UF, 50V, 10%, BULK |
| C53, 52 | 24G407 | CAP, RLYTIC, 47UF, 25V, +/-20% |
| C54, 55 | 24G686 | CAP, DISC, 2200PF, 125VAC, 20%, CSA |
| C56 | 24G698 | CAP, RLYTIC, 1UF, 160V, 20% |
| C57 | 24G697 | CAP, RLYTIC, 47UF, 250V, 20% |
| CR21 | 50C5-2:A | DIODE, SIL, 75V, 100mA, 25uA, 4148 |
| D1-3, 6 | 16G27 | DIODE, BRIDGE, 200V, 1.5A |
| D4, 5 | 16G28 | DIODE, BRIDGE, 200V, 3A |
| IC1 | 69G79 | IC, REG, -8V, 500mA, MC79M08CT |
| IC2 | 69G78 | IC, REG, +8V, 500mA, 78M08 |
| IC5 | 69G287 | IC, REG, NEG, ADJ, LM337T |
| IC13 | 69G212 | IC, REG, ADJ, 1.5A, LM317 |
| IC14 | 69G212 | IC, REG, ADJ, 1.5A, LM317 |
| L1, 2 | 46G92 | IND, WIREFORM, 50uH, 1.5A |
| R3 | 14A38-3923A | RES, MET.F, 3.92K, 1/4W, 1%, 100PPM |
| R4 | 14A38-4702A | RES, MET.F, 470, 1/4W, 1%, 100PPM |
| R5 | 14A38-2703A | RES, MET.F, 2.7K, 1/4W, 1%, 100PPM |
| R6 | 14A38-6813A | RES, MET.F, 6.81K, 1/4W, 1%, 100PPM |
| R7 | 14A38-1003A | RES, MET.F, 1K, 1/4W, 1%, 100PPM |
| R9-11 | 14A38-2402A | RES, MET.F, 240, 1/4W, 1%, 100PPM |
| R13 | 14A38-3013A | RES, MET.F, 3.01K, 1/4W, 1%, 100PPM |
| R15, 16 | 14A38-9093A | RES, MET.F, 9.09K, 1/4W, 1%, 100PPM |
| R17 | 14C1-682 | RES, CARBON, 6.8K, 1/4W, 5% |
| R50, 51 | 14C4-226 | RES, CARBON, 22M, 1/2W, 5% |
| R45 | 14A38-2402A | RES, MET.F, 240, 1/4W, 1%, 100PPM |
| R46 | 15C26-2 | POT, MVPC CERM, 200, 1/2W, 20% |
| R47 | 14A38-1603A | RES, MET.F, 1.6K, 1/4W, 1%, 100PPM |
| R48 | 14C29-4704A | RES, MET.F, 47K, 1/2W, 1%, 100PPM |
| R49 | 14A38-5622A | RES, MET.F, 562, 1/4W, 1%, 100PPM |
| TR2, 3 | 19A33-1 | TRANS, NPN, 40V, 200mA, 2N3904 |
| TR4, 5 | 19A34-1 | TRANS, PNP, 40V, 200mA, 2N3906 |

8000 DIGITAL BOARD

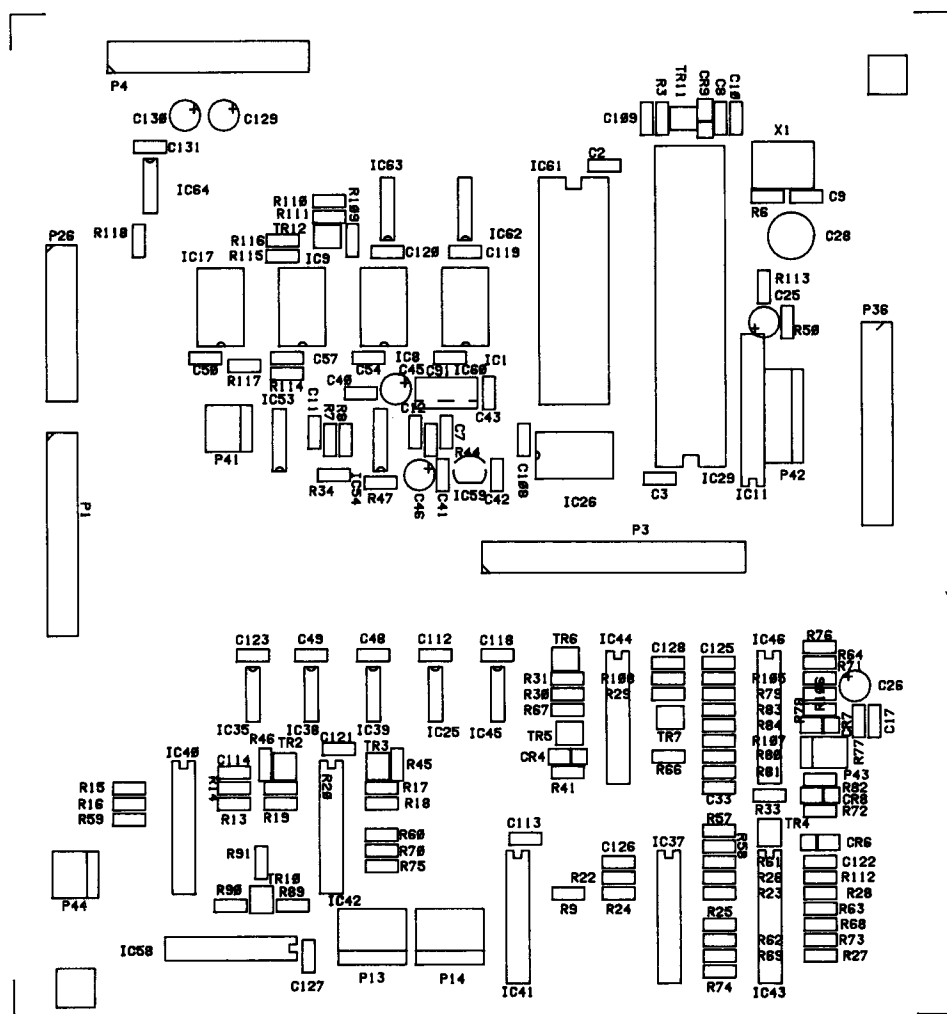

SCHEMATIC REFERENCE

PART NO.

DESCRIPTION

DIGITAL (8000) BOARD

C2,3,7,40-43,48-50,24G575

54,57,91,108,109,

112-114,118-123,

125-129,131

C8,9

C10

C11,12,17

C25,26,45,46,

129,130

C28

C33

CR4,6-9

IC1

IC8,9,17

IC11

IC25,64

IC26

IC29

IC35

IC37,58

IC38,39

IC40,42,43

IC41

IC44

IC45

IC46

IC53,54

IC59

IC60

24G615

24G607

24G465

24G448

24G387

24G606

50G36

69G433

69G441

69G238

69G438

69G605

69G546

69G436

69G81

69G440

69G132

69G76

69G83

69G604

69G133

69G428

69G147

69G79

CAP,CHIP,.1UF,50V,10%,X7R

CAP,CHIP,33PF,50V,5%,NPO

CAP,CHIP,10PF,50V,.25PF,NPO

CAP,CHIP,.01uF,50V,10%,X7R

CAP,RLYTIC,10UF,35V,+/-20%

CAP,TRIM,2.5-18PF

CAP,CHIP,.001UF,50V,10%,X7R

SMT DIODE,SIL,75V,100MA,4148

SMTIC,F-FLOP,D,OCTAL,74HC373

SMTIC,F-FLOP,TRI-S,D,74HC374

IC,RES NET,PULLUP, 8 X 100K

SMTIC,NAND,2-IN,74HC00

SMTIC,BUFFER,74HCT244

IC,MICRO,8032

SMTIC,F-FLOP,DUAL,D,74HC74

IC,F-FLOP,"D",DUAL,10231,ECL

SMTIC,COUNTER,BINARY,74HC393

IC,NOR,2-IN,10H102

IC,NOR,2-IN,ECL,10102

IC,F-FLOP,J-K,DUAL,10135

SMTIC,F-FLOP,DUAL,D,74F74

IC,3xLINE,ECL,16 PIN,10H116

SMTIC,CONV,8BIT,DAC-08E

IC,REG,+8V,100mA,78L08,TTL

IC,REG,-8V,500mA,MC79MO8CT

**SCHEMATIC
REFERENCE**

PART NO.

DESCRIPTION

DIGITAL (8000) BOARD CONTINUED

| | | |
|---|--------------|------------------------------------|
| IC61 | 69G536 | IC, EPROM, 27C512 |
| IC62,63 | 69G695 | SMTIC, 3 TO 8 DECODER, 74HC237 |
| R3 | 14G102-5112A | RES, CHIP, 511, 1/8W, 1%, 100PPM |
| R6 | 14G102-1302A | RES, CHIP, 130, 1/8W, 1%, 100PPM |
| R7 | 14G102-4324A | RES, CHIP, 43.2K, 1/8W, 1%, 100PPM |
| R8,9,13-20, 22-31,33,89,90, 108,109,113 | 14G102-1003A | RES, CHIP, 1K, 1/8W, 1%, 100PPM |
| R34 | 14G102-4754A | RES, CHIP, 47.5K, 1/8W, 1%, 100PPM |
| R41 | 14G102-2002A | RES, CHIP, 200, 1/8W, 1%, 100PPM |
| R44-47,91 | 14G102-1503A | RES, CHIP, 1.5K, 1/8W, 1%, 100PPM |
| R50 | 14G102-8253A | RES, CHIP, 8.25K, 1/8W, 1%, 100PPM |
| R57 | 14G102-9092A | RES, CHIP, 909, 1/8W, 1%, 100PPM |
| R58,82,83 | 14G102-3323A | RES, CHIP, 3.32K, 1/8W, 1%, 100PPM |
| R59 | 14G102-1502A | RES, CHIP, 150, 1/8W, 1%, 100PPM |
| R60-64 | 14G102-2003A | RES, CHIP, 2K, 1/8W, 1%, 100PPM |
| R66 | 14G102-6812A | RES, CHIP, 681, 1/8W, 1%, 100PPM |
| R67 | 14G102-4321A | RES, CHIP, 43.2, 1/8W, 1%, 100PPM |
| R68-72,81 | 14G102-2673A | RES, CHIP, 2.67K, 1/8W, 1%, 100PPM |
| R73-76,110 | 14G102-1504A | RES, CHIP, 15K, 1/8W, 1%, 100PPM |
| R77 | 14G102-7501A | RES, CHIP, 75, 1/8W, 1%, 100PPM |
| R78 | 14G102-6192A | RES, CHIP, 619, 1/8W, 1%, 100PPM |
| R79 | 14G102-1303A | RES, CHIP, 1.3K, 1/8W, 1%, 100PPM |
| R80,105-107 | 14G102-2672A | RES, CHIP, 267, 1/8W, 1%, 100PPM |
| R84,111 | 14G102-6193A | RES, CHIP, 6.19K, 1/8W, 1%, 100PPM |
| R112 | 14G102-4991A | RES, CHIP, 49.9, 1/8W, 1%, 100PPM |
| R114-118 | 14G102-1003A | RES, CHIP, 1K, 1/8W, 1%, 100PPM |
| TR2-7,10 | 19G95 | SMT TRANS, PNP, 40V, 200MA, 3906 |
| TR11,12 | 19G92 | SMT TRANSISTOR, NPN, 3904, SOT23 |
| X1 | 47A36 | CRYSTAL, QTZ, 10MHZ, .005%, 30PPM |

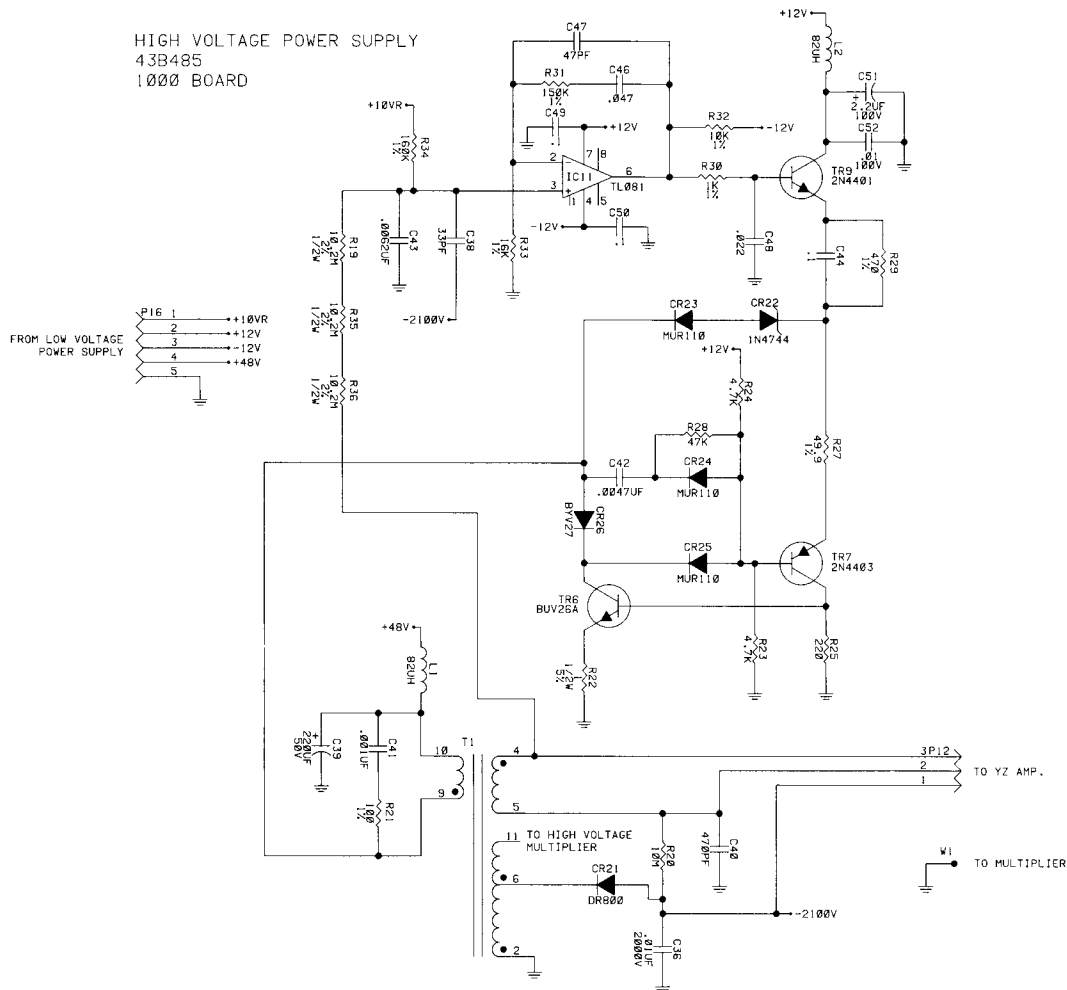

1000 HIGH VOLTAGE POWER SUPPLY BOARD

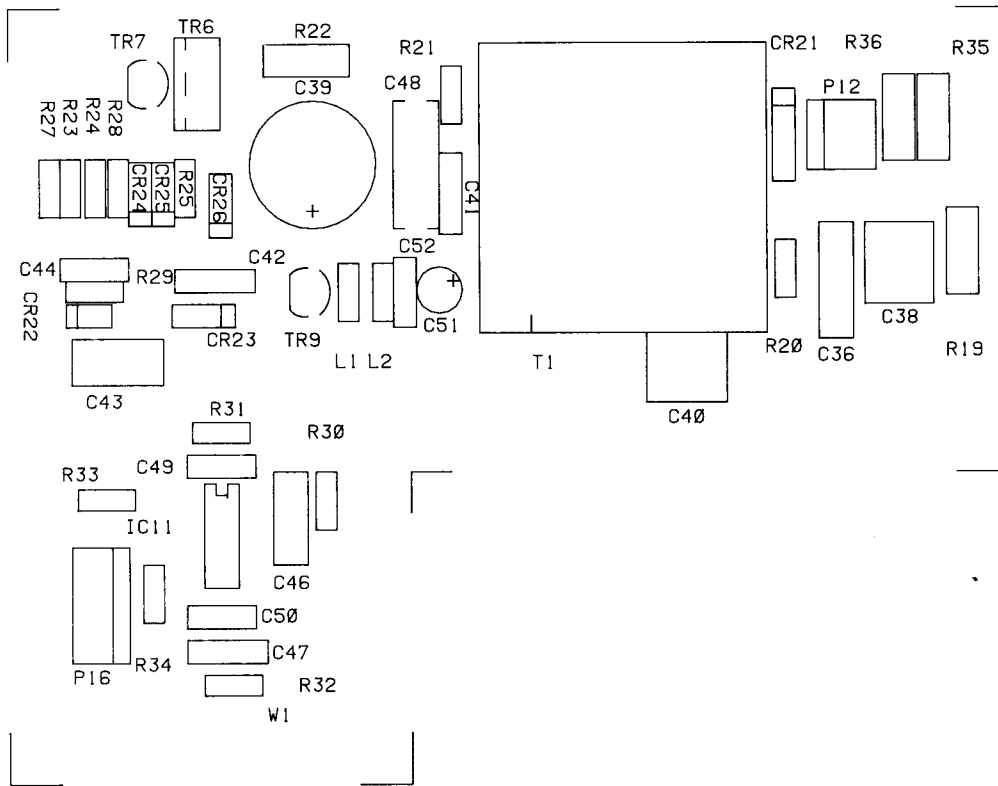

SCHEMATIC REFERENCE

PART NO.

DESCRIPTION

HIGH VOLTAGE POWER SUPPLY (1000) BOARD

| SCHEMATIC REFERENCE | PART NO. | DESCRIPTION |
|---------------------|-------------|--------------------------------|
| C36 | 24G221 | CAP,DISC,.01UF,3000V,+80/-20% |
| C38 | 24G621 | CAP,DISC,33PF,3KV,20% |
| C39 | 24G411 | CAP,RLYTIC,220UF,50V,+/-20% |
| C40 | 24G622 | CAP,DISC,470PF,3KV,20% |
| C41 | 24G214 | CAP,DISC,.001UF,500V,10%,Z5F |
| C42 | 24G125 | CAP,DISC,.0047uF,200V,20%,Z5U |
| C43 | 24G261 | CAP,POLY,.0062UF,33V,5% |
| C44,49,50 | 24G482 | CAP,MYLAR,.1UF,50V,5%,5MM |
| C46 | 24G212 | CAP,MYLAR,.047UF,100V,10% |
| C47 | 24G176 | CAP,DISC,47PF,500V,5%,NPO |
| C48 | 24G195 | CAP,MYLAR,.022UF,250V,10% |
| C51 | 24G569 | CAP,RLYTIC,2.2UF,100V,20% |
| C52 | 24G207 | CAP,DISC,.01UF,100V,20% |
| CR21 | 16G16 | DIODE,FAST REC,8KV,25mA,1uA |
| CR22 | 50C4-11 | DIODE,ZENER,15V,61mA,5%,IN4744 |
| CR23-25 | 16G21 | DIODE,FAST REC,100V,1A,10uA |
| CR26 | 50G39 | DIODE,FAST RECOVERY,BYV27 |
| IC11 | 9G63 | IC,OP-AMP,SINGLE,BIFET,TLO81 |
| L1,2 | 46G105 | IND,MINIATURE,82uH,,10% |
| R19,35,36 | 14C29-1027A | RES,MET.F,10.2M,1/2W,1%,100PPM |
| R20 | 14C1-106 | RES,CARBON,10M,1/4W,5% |
| R21 | 14A38-1002A | RES,MET.F,100,1/4W,1%,100PPM |
| R22 | 14C4-10 | RES,CARBON,1,1/2W,5% |
| R23,24 | 14C1-472 | RES,CARBON,4.7K,1/4W,5% |
| R25 | 14C1-221 | RES,CARBON,220,1/4W,5% |
| R27 | 14A38-4991A | RES,MET.F,49.9,1/4W,1%,100PPM |
| R28 | 14C1-473 | RES,CARBON,47K,1/4W,5% |
| R29 | 14A38-4702A | RES,MET.F,470,1/4W,1%,100PPM |
| R30 | 14A38-1003A | RES,MET.F,1K,1/4W,1%,100PPM |
| R31 | 14A38-1505A | RES,MET.F,150K,1/4W,1%,100PPM |
| R32 | 14A38-1004A | RES,MET.F,10K,1/4W,1%,100PPM |
| R33 | 14A38-1604A | RES,MET.F,16K,1/4W,1%,100PPM |
| R34 | 14A38-1605A | RES,MET.F,160K,1/4W,1%,100PPM |
| T1 | 28B125 | TRANSFORMER,FLYBACK,HV BOARD |
| TR6 | 19G112 | TRANS,NPN,FAST SW,BUV26A |
| TR7 | 19G40 | TRANS,PNP,40V,500MA,2N4403 |
| TR9 | 19A44 | TRANS,NPN,40V,600mA,,2N4401 |

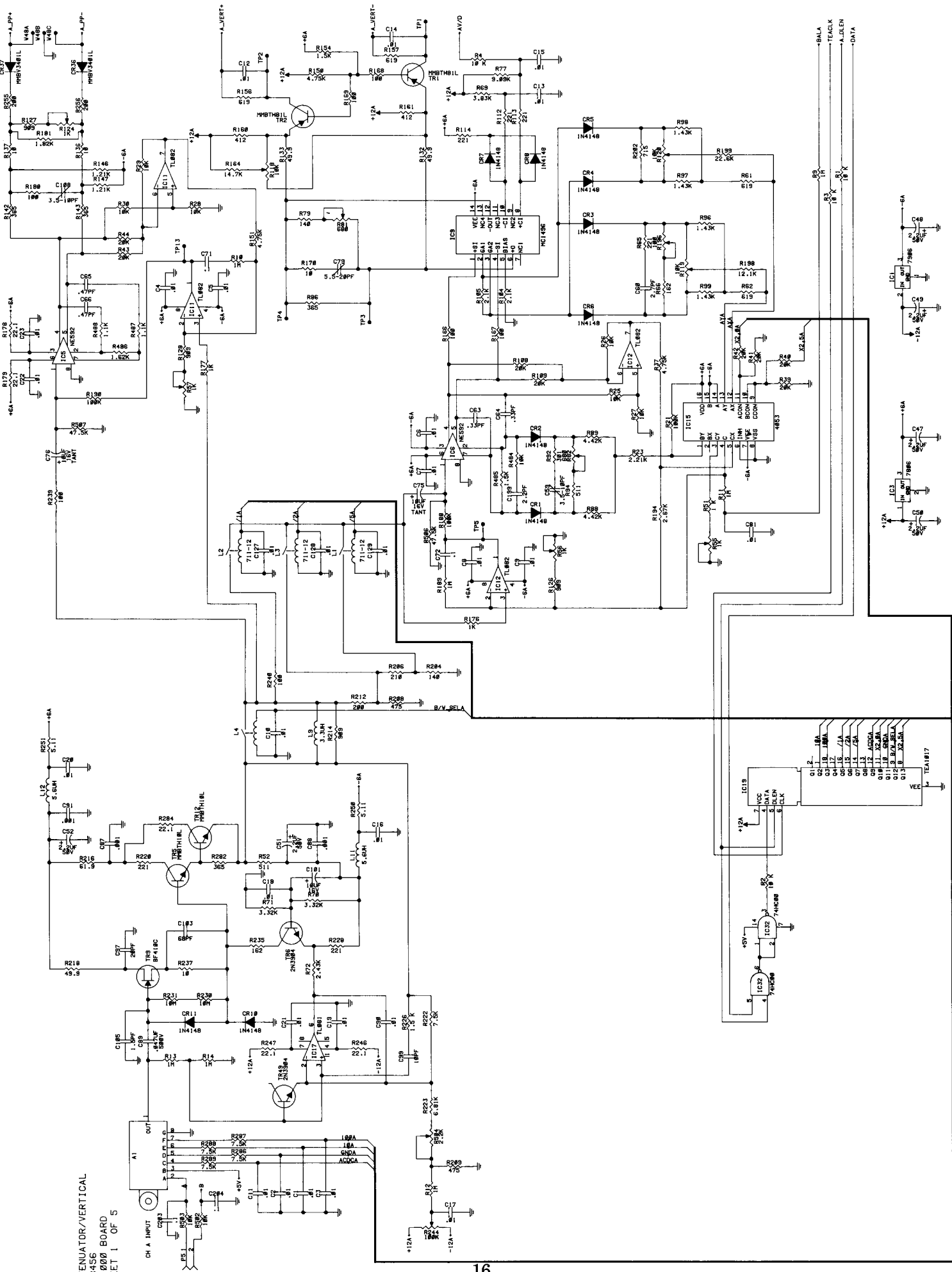

ATTENUATOR/VERTICAL
439456
12,000 BOARD
SHEET 1 OF 5

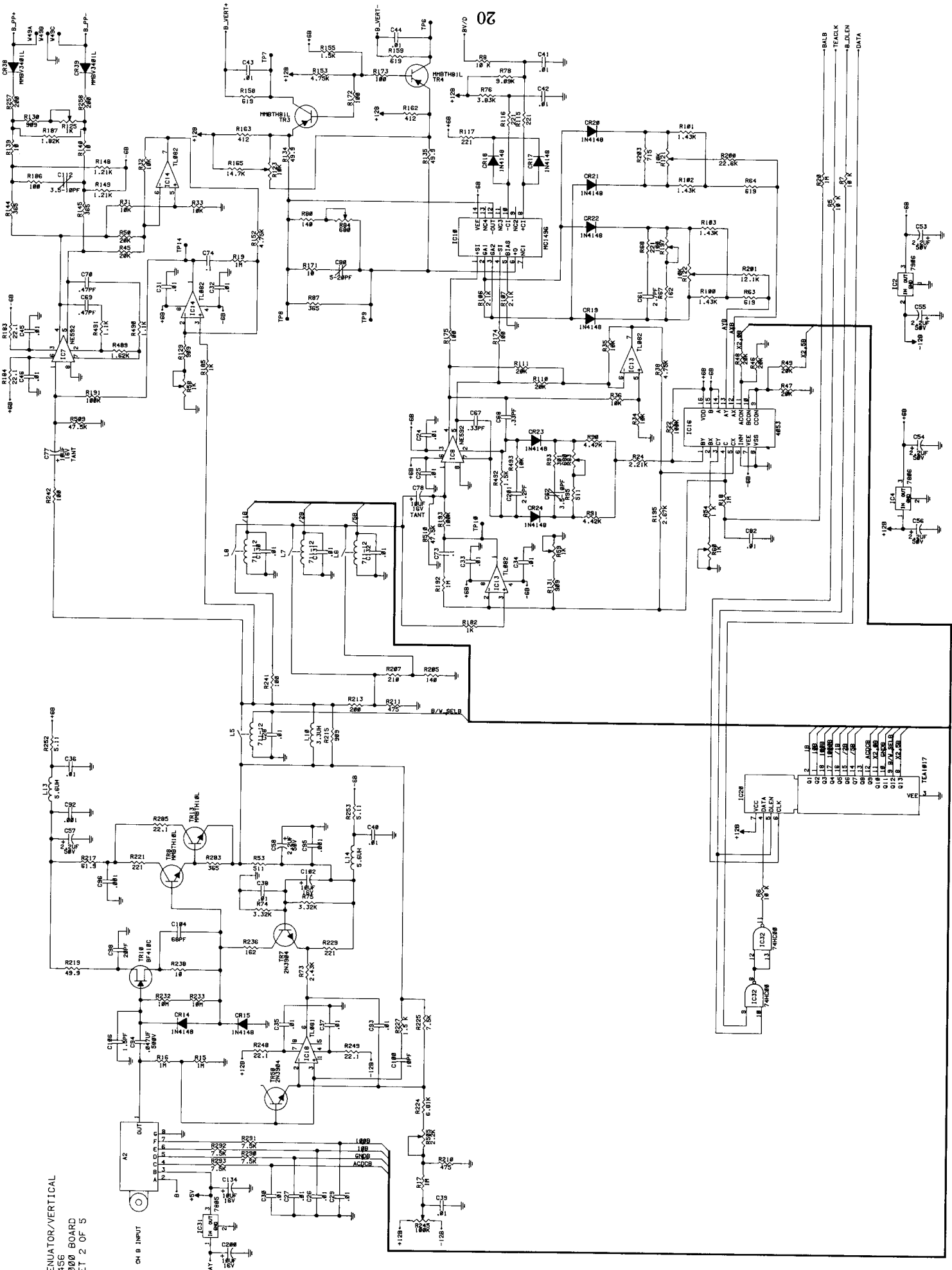

VOLTAGE PEAK-PEAK AMPLIFIER

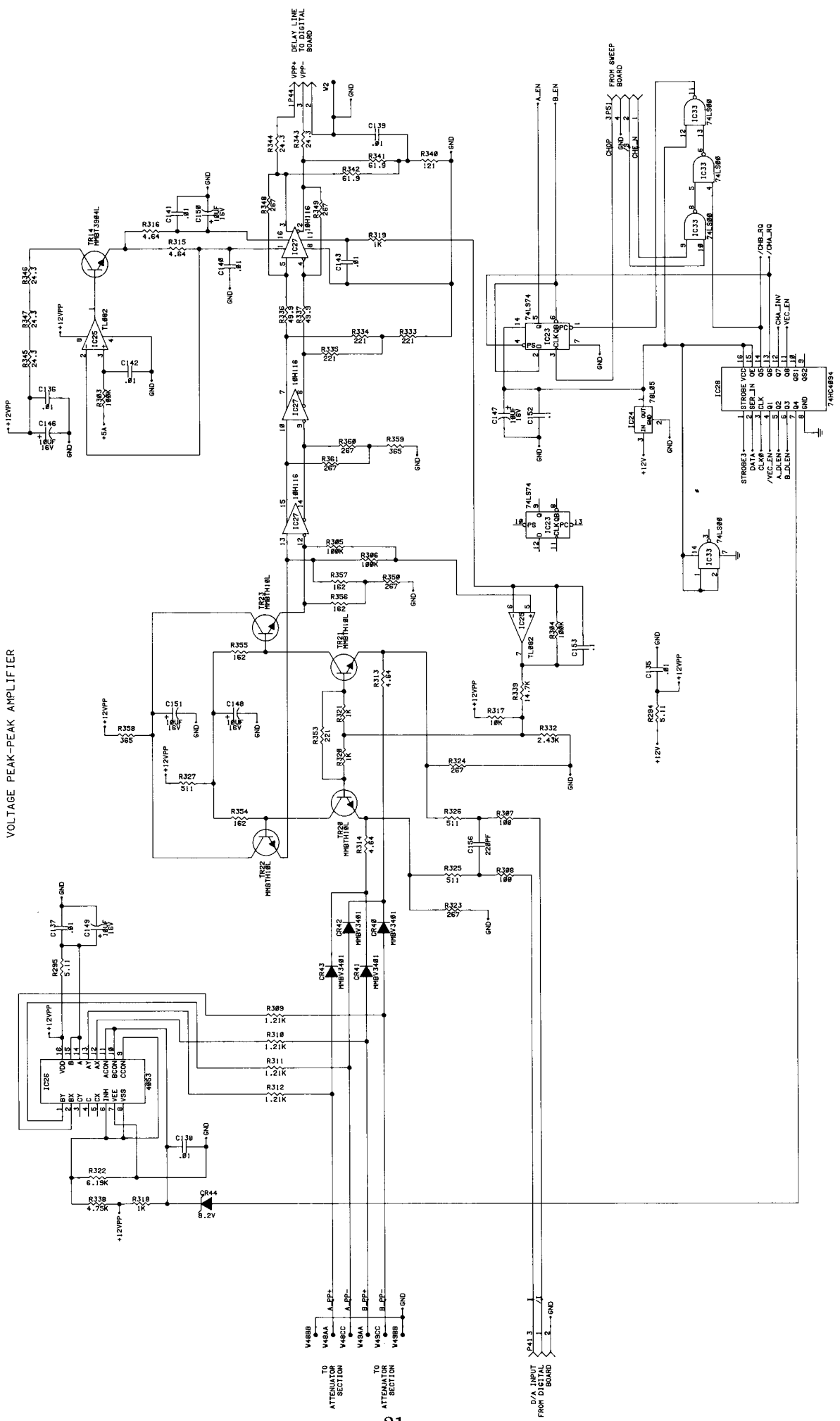

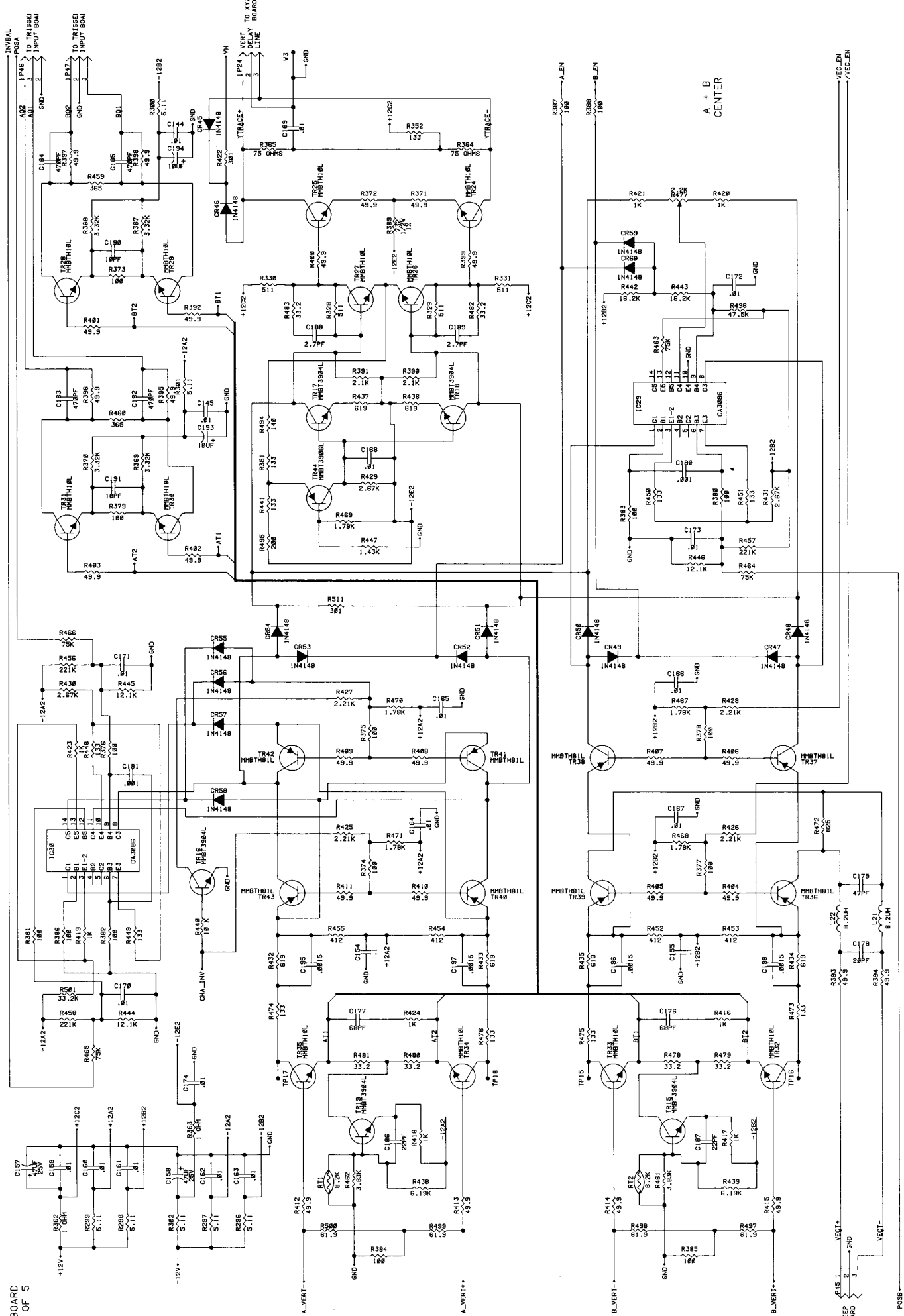

**SCHEMATIC
REFERENCE**

PART NO.

DESCRIPTION

ATTENUATOR (12,000) BOARD CONTINUED

| | | |
|--|--------------|--------------------------------|
| CR36-43 | 50G35 | SMT DIODE,PIN,MMBV3401 |
| CR44 | 50C4-1 | DIODE,ZENER,8.2V,110mA,5%,4738 |
| CR45-60 | 50G36 | SMT DIODE,SIL,75V,100MA,4148 |
| IC1,2 | 69G259 | IC,REG,NEG 1 AMP, 6V, 7906T |
| IC3,4 | 69G258 | IC,REG,1AMP,6V,7806T |
| IC5-8 | 69G702 | SMTIC,VIDEO AMP,NE592D8 |
| IC9,10 | 69G430 | SMTIC,MOD,BALANCED,1496 |
| IC11,14,25 | 69G432 | SMTIC,OP-AMP,DUAL,BIFET,TL082 |
| IC12,13 | 69G750 | SMTIC,DUAL,BIFET,TL082ACD |
| IC15,16,26 | 69G450 | SMTIC,SW,TRIPLE,4053 |
| IC17,18,22 | 69G463 | SMTIC,OP-AMP,SINGLE,TL081 |
| IC19,20 | 69G506 | IC,CONVERTER,S/P,TEA1017 |
| IC23 | 69G533 | SMTIC,F-FLOP,D,74LS74 |
| IC24 | 69G29 | IC,REG,+5V,100mA,78L05 |
| IC27 | 69G133 | IC,3xLINE,ECL,16 PIN,10H116 |
| IC28 | 69G693 | SMTIC,8 BIT SHIFT REG,74HC4094 |
| IC29,30 | 69G502 | SMTIC,TRANS ARRAY,NPN,3086 |
| IC31 | 69Z352 | IC,REG,+5V,1A,7805 |
| IC32 | 69G438 | SMTIC,NAND,2-IN,74HC00 |
| IC33 | 69G500 | SMTIC,NAND,2-IN,74LS00 |
| L1-8 | 41G35 | RELAY,REED,711-12 |
| L9,10 | 46G102 | IND,RADIAL,3.3uH,100mA,10 |
| L11-18 | 46G133 | IND,AXIAL,5.6UH,50MA,10% |
| L21,22 | 46G122 | IND,COIL,8.2uH,25mA,10% |
| R1-8,25-36,317, 440,484,493, 502,503 | 14G102-1004A | RES,CHIP,10K,1/8W,1%,100PPM |
| R9-12,13-20,189,192 | 14G102-1006A | RES,CHIP,1M,1/8W,1%,100PPM |
| R21,22,188,190, 191,193,303-306 | 14G102-1005A | RES,CHIP,100K,1/8W,1%,100PPM |
| R23,24,425-428 | 14G102-2213A | RES,CHIP,2.21K,1/8W,1%,100PPM |
| R37,38,150-153, 268,269,338 | 14G102-4753A | RES,CHIP,4.75K,1/8W,1%,100PPM |
| R39-50,108-111 | 14G102-2004A | RES,CHIP,20K,1/8W,1%,100PPM |
| R51,54,176,177, 182,185 | 14G102-1003A | RES,CHIP,1K,1/8W,1%,100PPM |
| R52,53,94,95, 277,325-331 | 14G102-5112A | RES,CHIP,511,1/8W,1%,100PPM |
| R55-60,124,125 | 15G50-102 | SMT,POT,VPC CERM,1K,.2W,30% |
| R61-64,156-159, 432-437 | 14G102-6192A | RES,CHIP,619,1/8W,1%,100PPM |
| R65,68,112-117, 220,221,228,229, 333-335,353 | 14G102-2212A | RES,CHIP,221,1/8W,1%,100PPM |
| R66,67,235,236, 354-357 | 14G102-1622A | RES,CHIP,162,1/8W,1%,100PPM |
| R69,76,461,462 | 14G102-3833A | RES,CHIP,3.83K,1/8W,1%,100PPM |
| R70,71,74,75, 366-370,501 | 14G102-3323A | RES,CHIP,3.32K,1/8W,1%,100PPM |
| R72,73,332 | 14G102-2433A | RES,CHIP,2.43K,1/8W,1%,100PPM |
| R77,78 | 14G102-9093A | RES,CHIP,9.09K,1/8W,1%,100PPM |
| R79,80,204,205,494 | 14G102-1402A | RES,CHIP,140,1/8W,1%,100PPM |
| R81-84 | 15G50-681 | SMT POT,VPC CERM,680,.2W,30% |
| R86,87,142-145, 254,282,283,358, 359,459,460 | 14G102-3652A | RES,CHIP,365,1/8W,1%,100PPM |
| R88-91 | 14G102-4423A | RES,CHIP,4.42K,1/8W,1%,100PPM |
| R92,93,422,511 | 14G102-3012A | RES,CHIP,301,1/8W,1%,100PPM |
| R96-103,447 | 14G102-1433A | RES,CHIP,1.43K,1/8W,1%,100PPM |
| R104-107,272,273, 390,391 | 14G102-2103A | RES,CHIP,2.1K,1/8W,1%,100PPM |
| R118-123 | 15G50-103 | SMT POT,VPC CERM,10K,.2W,30% |
| R126-131,214,215 | 14G102-9092A | RES,CHIP,909,1/8W,1%,100PPM |
| R132-135,218,219, 267,274-276,336, 337,392-399 | 14G102-4991A | RES,CHIP,49.9,1/8W,1%,100PPM |
| R136-140,170,171, 237,238,512,513 | 14G102-1001A | RES,CHIP,10,1/8W,1%,100PPM |
| R146-149,263, 309-312 | 14G102-1213A | RES,CHIP,1.21K,1/8W,1%,100PPM |
| R154,155,226,227, 485,492 | 14G102-1503A | RES,CHIP,1.5K,1/8W,1%,100PPM |
| R160-163,452-455 | 14G102-4122A | RES,CHIP,412,1/8W,1%,100PPM |
| R164,165,271,339 | 14G102-1474A | RES,CHIP,14.7K,1/8W,1%,100PPM |

| SCHEMATIC REFERENCE | PART NO. | DESCRIPTION |
|--|--------------|-------------------------------|
| ATTENUATOR (12,000) BOARD CONTINUED | | |
| R166-169,172-175, 180,186,239-243, 307 | 14G102-1002A | RES,CHIP,100,1/8W,1%,100PPM |
| R178,179,183, 184,246-249, 278,284,285 | 14G102-2211A | RES,CHIP,22.1,1/8W,1%,100PPM |
| R181,187 | 14G102-1823A | RES,CHIP,1.82K,1/8W,1%,100PPM |
| R194,195,270, 429-430 | 14G102-2673A | RES,CHIP,2.67K,1/8W,1%,100PPM |
| R196,197 | 15G50-101 | SMT,POT,VPC CERM,100,.2W,30% |
| R198,201,262, 444-446 | 14G102-1214A | RES,CHIP,12.1K,1/8W,1%,100PPM |
| R199,200 | 14G102-2264A | RES,CHIP,22.6K,1/8W,1% |
| R202,203 | 14G102-7152A | RES,CHIP,715,1/8W,1%,100PPM |
| R206,207 | 14G102-2102A | RES,CHIP,210,1/8W,1%,100PPM |
| R208-211 | 14G102-4752A | RES,CHIP,475,1/8W,1%,100PPM |
| R212,213,255-258, 495 | 14G102-2002A | RES,CHIP,200,1/8W,1%,100PPM |
| R216,217,341,342, 497-500 | 14G102-6191A | RES,CHIP,61.9,1/8W,1%,100PPM |
| R222,225,286-293 | 14G102-7503A | RES,CHIP,7.5K,1/8W,1%,100PPM |
| R223,224 | 14G102-6813A | RES,CHIP,6.81K,1/8W,1%,100PPM |
| R244,245 | 15G50-104 | SMT POT,VPC CERM,100K,.2W,30% |
| R250-253,259-261, 294-302 | 14G102-5110A | RES,CHIP,5.11,1/8W,1%,100PPM |
| R264 | 14G102-6815A | RES,CHIP,681K,1/8W,1%,100PPM |
| R265,478-483 | 14G102-3321A | RES,CHIP,33.2,1/8W,1%,100PPM |
| R266 | 14G102-3165A | RES,CHIP,316K,1/8W,1%,100PPM |
| R279 | 14G102-1826E | RES,CHIP,1.82M,1/8W,1%,500PPM |
| R313-316 | 14G102-4640A | RES,CHIP,4.64,1/8W,1%,100PPM |
| R322,438,439 | 14G102-6193A | RES,CHIP,6.19K,1/8W,1%,100PPM |
| R323,324,348-350, 360,361 | 14G102-2672A | RES,CHIP,267,1/8W,1%,100PPM |
| R343-347 | 14G102-2431A | RES,CHIP,24.3,1/8W,1%,100PPM |
| R351,352,441, 448-451,473-476 | 14G102-1332A | RES,CHIP,133,1/8W,1%,100PPM |
| R364,365 | 14G102-7501A | RES,CHIP,75,1/8W,1%,100PPM |
| R371,372,400, 401-415 | 14G102-4991A | RES,CHIP,49.9,1/8W,1%,100PPM |
| R389 | 14C29-7322A | RES,MET.F,732,1/2W,1%,100PPM |
| R442,443 | 14G102-1624A | RES,CHIP,16.2K,1/8W,1%,100PPM |
| R456-458 | 14G102-2215A | RES,CHIP,221K,1/8W,1%,100PPM |
| R463-466 | 14G102-7504A | RES,CHIP,75K,1/8W,1%,100PPM |
| R467-471 | 14G102-1783A | RES,CHIP,1.78K,1/8W,1%,100PPM |
| R472 | 14G102-8252A | RES,CHIP,825,1/8W,1%,100PPM |
| R477,504,505 | 15G50-222 | SMT POT,VPC CERM,2.2K,.2W,30% |
| R486,489 | 14G102-1623A | RES,CHIP,1.62K,1/8W,1%,100PPM |
| R496,506-510 | 14G102-4754A | RES,CHIP,47.5K,1/8W,1%,100PPM |
| TR1-4,36-43 | 19G113 | SMTTRANS,PNP,600MHZ,MMBTH81L |
| TR5,8,12,13,20-35 | 19G98 | SMT TRANS,VHF/UHF AMP,MMBTH10 |
| TR6,7,14-19,45-48 | 19G92 | SMT TRANSISTOR,NPN,3904,SOT23 |
| TR9-11 | 19G114 | TRANS,N-CHNL,LO NOISE,BF410 |
| TR44 | 19G95 | SMT TRANS,PNP,40V,200MA,3906 |

12,000 ATTENUATOR BOARD

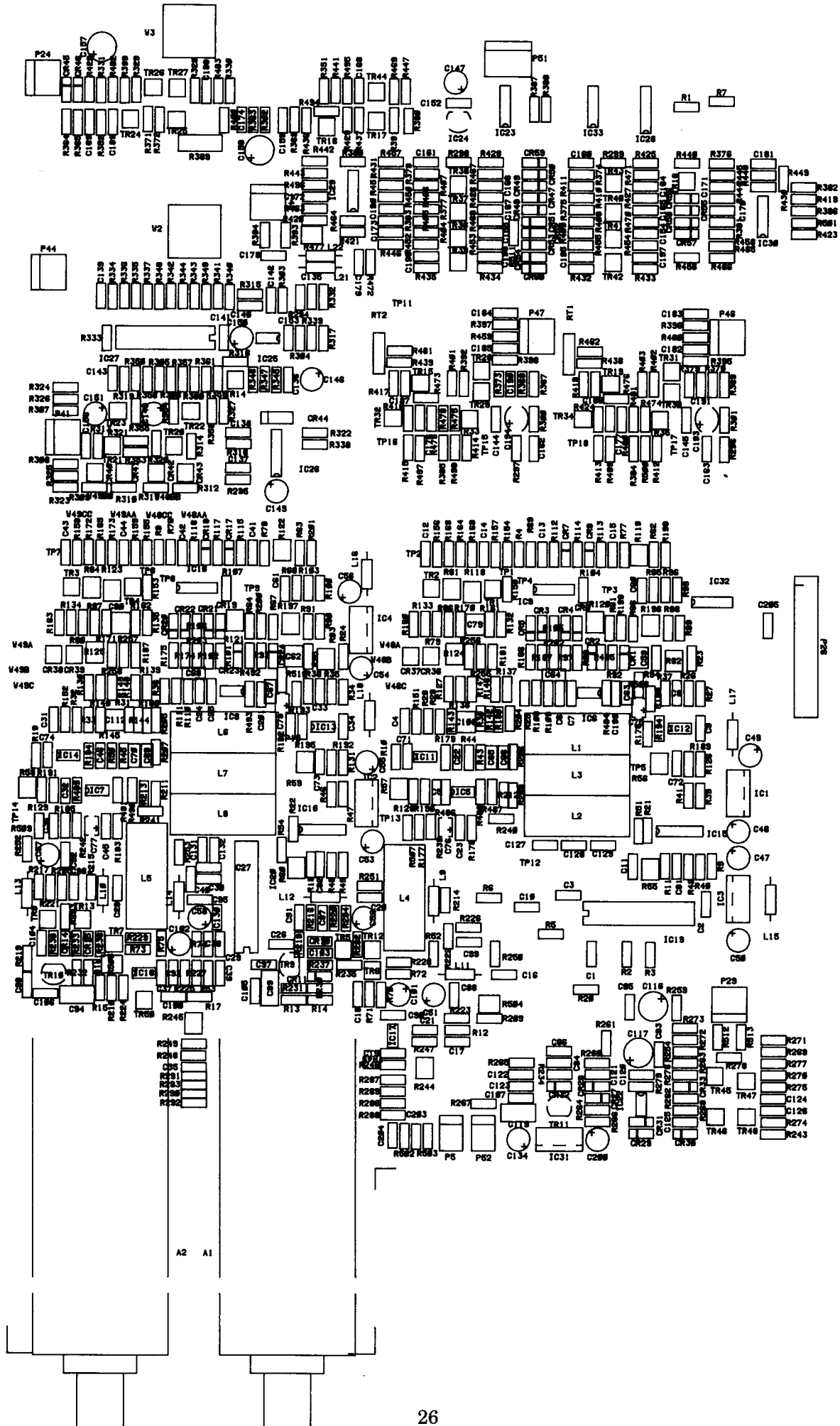

TRIGGER INPUT
43B454
10,000 BOARD

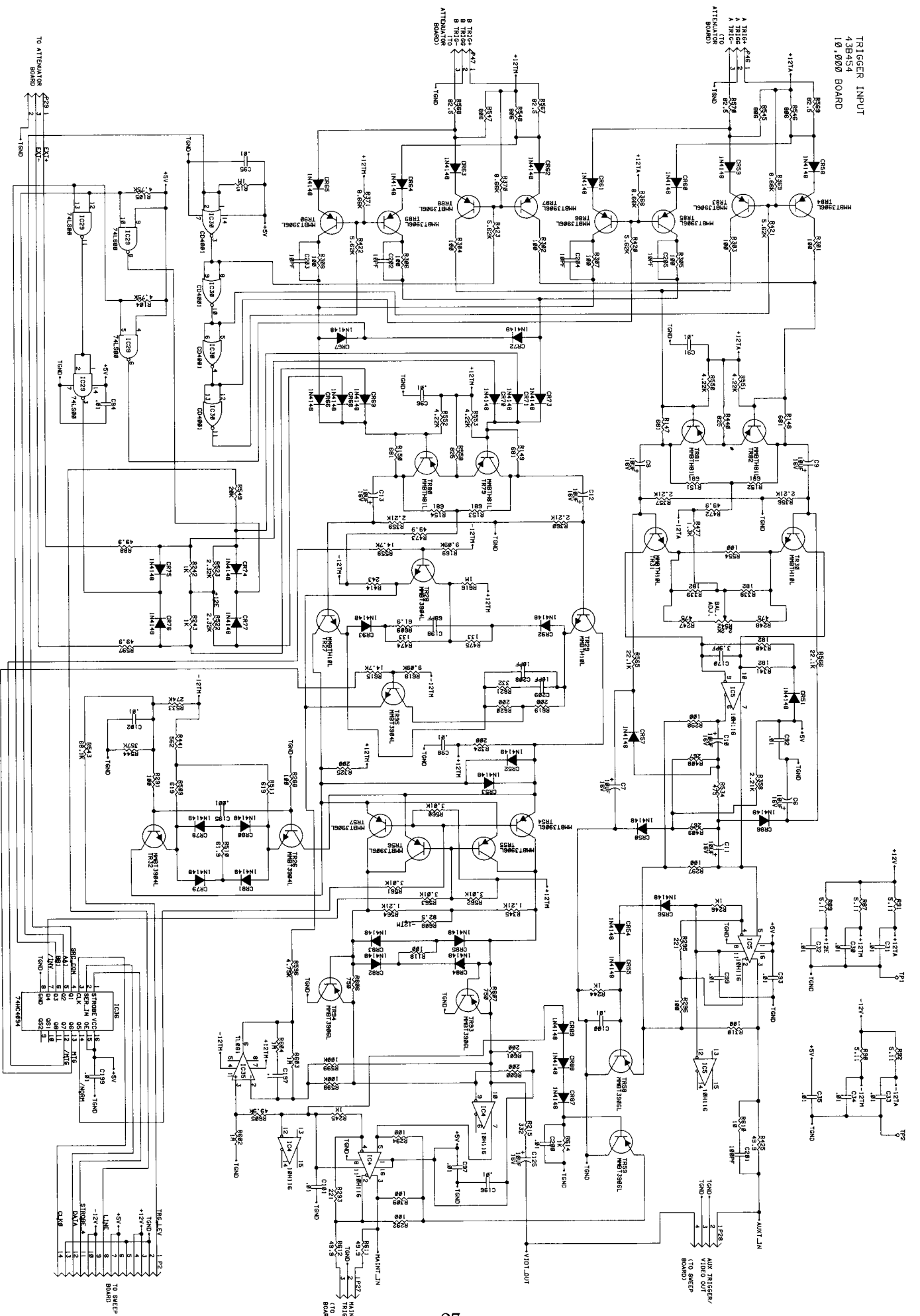

10,000 TRIGGER INPUT P/P BOARD

H2

H1

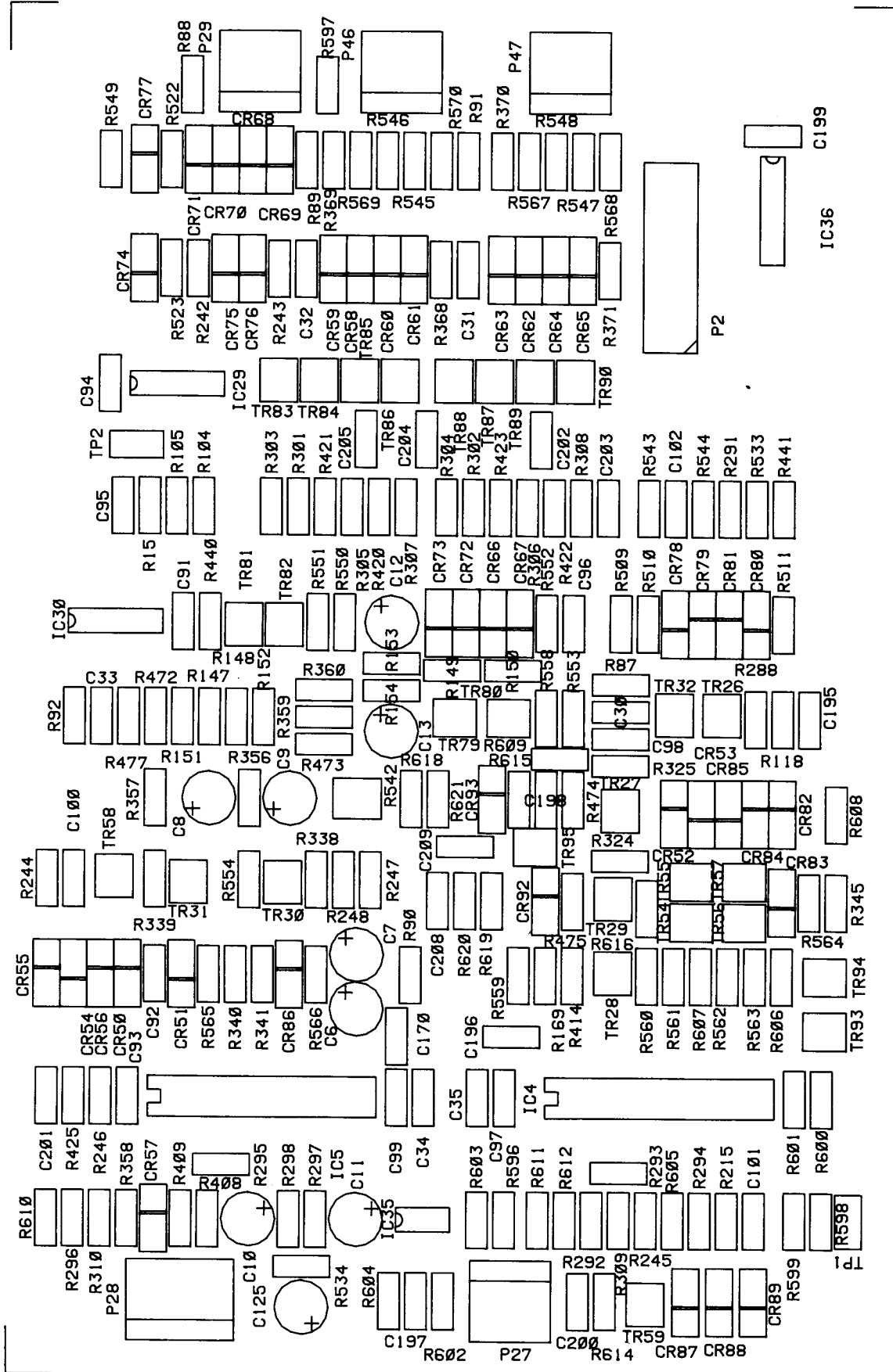

| SCHEMATIC REFERENCE | PART NO. | DESCRIPTION |
|---|--------------|--------------------------------|
| TRIGGER INPUT P/P (10,000) BOARD | | |
| C30-35,91-102,196,199,200 | 24G465 | CAP,CHIP,.01uF,50V,10%,X7R |
| C6-13,125 | 24G382 | CAP,RLYTIC,10UF,16V,20% |
| C170 | 24G566 | CAP,CHIP,3.9PF,50V,10%,X7R |
| C195 | 24G606 | CAP,CHIP,.001UF,50V,10%,X7R |
| C197 | 24G575 | CAP,CHIP,.1UF,50V,10%,X7R |
| C198 | 24G587 | CAP,CHIP,68PF,50V,5%,NPO |
| C201 | 24G612 | CAP,CHIP,100PF,50V,5%,NPO |
| C202-205,208,209 | 24G607 | CAP,CHIP,10PF,50V,.25PF,NPO |
| CR50-89,92,93 | 50G36 | SMT DIODE,SIL,75V,100MA,4148 |
| IC4,5 | 69G133 | IC,3xLINE,ECL,16 PIN,10H116 |
| IC29 | 69G500 | SMTIC,NAND,2-IN,74LS00 |
| IC30 | 69G497 | SMTIC,NOR,2-IN,4001 |
| IC35 | 69G463 | SMTIC,OP-AMP,SINGLE,TL081 |
| IC36 | 69G693 | SMTIC,8 BIT SHIFT REG,74HC4094 |
| R15,602-604,616 | 14G102-1006A | RES,CHIP,1M,1/8W,1%,100PPM |
| R87-92 | 14G102-5110A | RES,CHIP,5.11,1/8W,1%,100PPM |
| R88,425,472,473,597,611,612 | 14G102-4991A | RES,CHIP,49.9,1/8W,1%,100PPM |
| R104,105,596 | 14G102-4753A | RES,CHIP,4.75K,1/8W,1%,100PPM |
| R118,288,291,292 | 14G102-1002A | RES,CHIP,100,1/8W,1%,100PPM |
| R147-154 | 14G102-6812A | RES,CHIP,681,1/8W,1%,100PPM |
| R169,618 | 14G102-9093A | RES,CHIP,9.09K,1/8W,1%,100PPM |
| R215,621 | 14G102-3322A | RES,CHIP,332,1/8W,1%,100PPM |
| R242-246,614 | 14G102-1003A | RES,CHIP,1K,1/8W,1%,100PPM |
| R247,248,534 | 14G102-4752A | RES,CHIP,475,1/8W,1%,100PPM |
| R293,295 | 14G102-2212A | RES,CHIP,221,1/8W,1%,100PPM |
| R294,296-310,554 | 14G102-1002A | RES,CHIP,100,1/8W,1%,100PPM |
| R324,325,600,601,619,620 | 14G102-2002A | RES,CHIP,200,1/8W,1%,100PPM |
| R338-341 | 14G102-1822A | RES,CHIP,182,1/8W,1%,100PPM |
| R345,564 | 14G102-1213A | RES,CHIP,1.21K,1/8W,1%,100PPM |
| R356-360 | 14G102-2213A | RES,CHIP,2.21K,1/8W,1%,100PPM |
| R368-371 | 14G102-8663A | RES,CHIP,8.66K,1/8W,1%,100PPM |
| R408,409 | 14G102-2672A | RES,CHIP,267,1/8W,1%,100PPM |
| R414 | 14G102-2432A | RES,CHIP,243,1/8W,1%,100PPM |
| R420-423 | 14G102-5623A | RES,CHIP,5.62K,1/8W,1%,100PPM |
| R440,558 | 14G102-8252A | RES,CHIP,825,1/8W,1%,100PPM |
| R441 | 14G102-5622A | RES,CHIP,562,1/8W,1%,100PPM |
| R474,475 | 14G102-1332A | RES,CHIP,133,1/8W,1%,100PPM |
| R477 | 14G102-1303A | RES,CHIP,1.3K,1/8W,1%,100PPM |
| R509,511 | 14G102-6192A | RES,CHIP,619,1/8W,1%,100PPM |
| R510,609 | 14G102-6191A | RES,CHIP,61.9,1/8W,1%,100PPM |
| R522,523 | 14G102-2323A | RES,CHIP,2.32K,1/8W,1%,100PPM |
| R533 | 14G102-2745A | RES,CHIP,274K,1/8W,1%,100PPM |
| R542 | 15G50-222 | SMT POT,VPC CERM,2.2K,2W,30% |
| R543 | 14G102-6814A | RES,CHIP,68.1K,1/8W,1%,100PPM |
| R544 | 14G102-3575A | RES,CHIP,357K,1/8W,1%,100PPM |
| R545-548 | 14G102-8062A | RES,CHIP,806,1/8W,1%,100PPM |
| R549 | 14G102-2004A | RES,CHIP,20K,1/8W,1%,100PPM |
| R550-553 | 14G102-4223A | RES,CHIP,4.22K,1/8W,1%,100PPM |
| R560-563 | 14G102-3013A | RES,CHIP,3.01K,1/8W,1%,100PPM |
| R565,566 | 14G102-2214A | RES,CHIP,22.1K,1/8W,1%,100PPM |
| R567-570,608 | 14G102-8251A | RES,CHIP,82.5,1/8W,1%,100PPM |
| R598,599 | 14G102-1005A | RES,CHIP,100K,1/8W,1%,100PPM |
| R599,615 | 14G102-1474A | RES,CHIP,14.7K,1.8W,1%,100PPM |
| R605 | 14G102-4994A | RES,CHIP,49.9K,1/8W,1%,100PPM |
| R606,607 | 14G102-7502A | RES,CHIP,750,1/8W,1%,100PPM |
| R610 | 14G102-1001A | RES,CHIP,10,1/8W,1%,100PPM |
| TR26,28,32,95 | 19G92 | SMT TRANSISTOR,NPN,3904,SOT23 |
| TR27,29-31 | 19G98 | SMT TRANS,VHF/UHF AMP,MMBTH10 |
| TR54-59,83-90,93,94 | 19G95 | SMT TRANS,PNP,40V,200MA,3906 |
| TR79-82 | 19G113 | SMTTRANS,PNP,600MHZ,MMBTH81L |

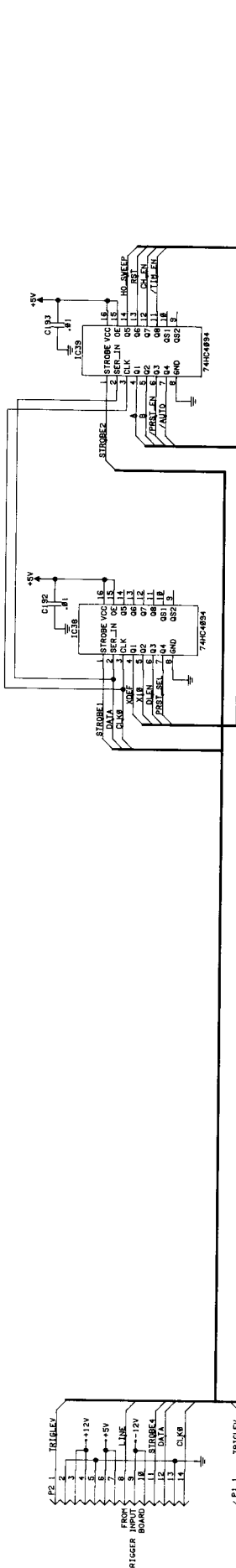
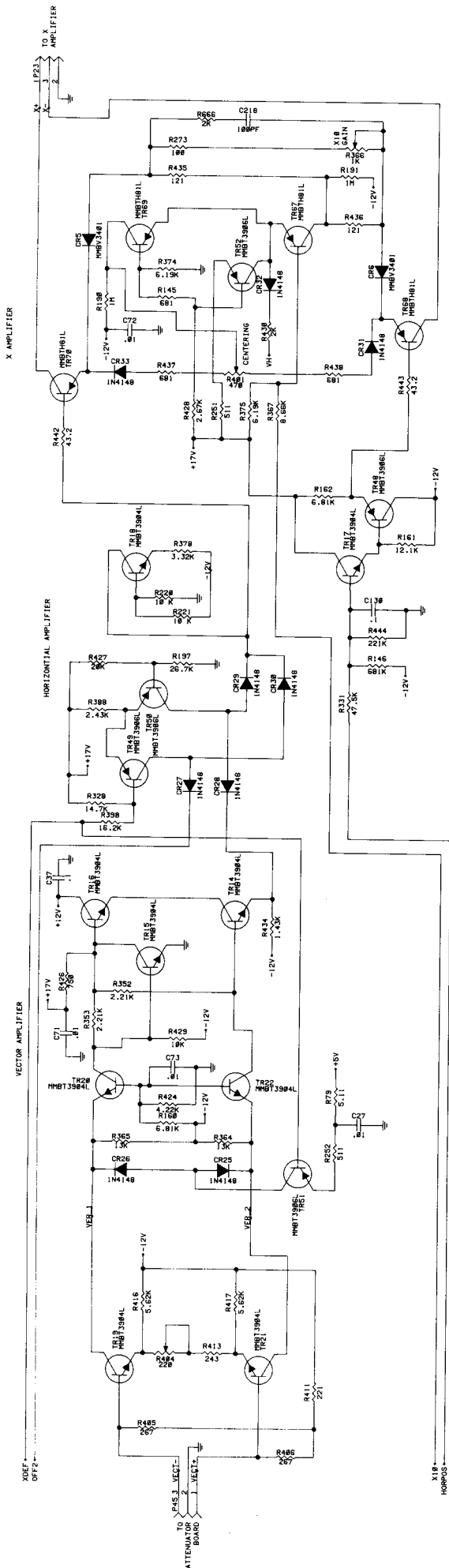

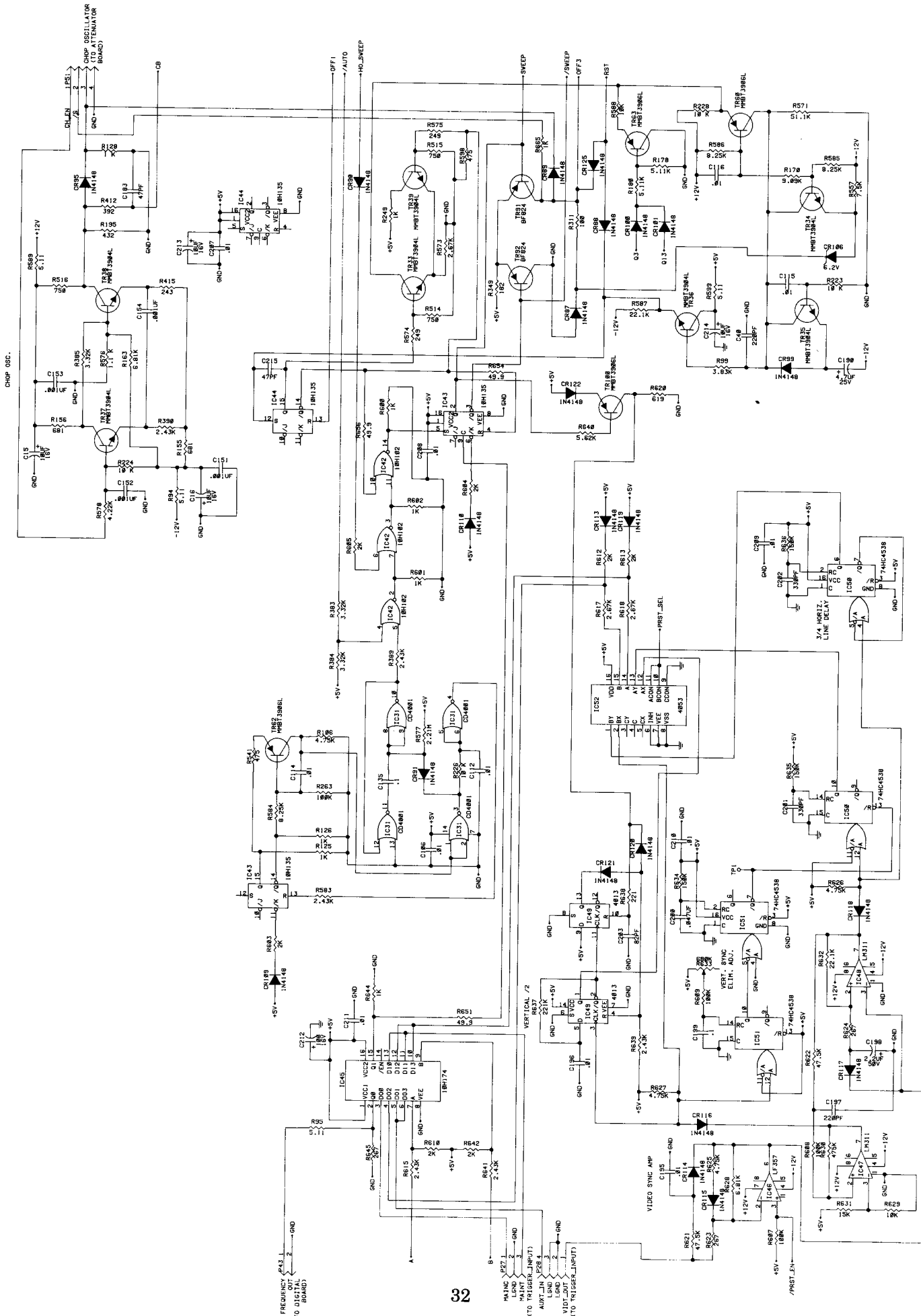

| SCHEMATIC REFERENCE | PART NO. | DESCRIPTION |
|--|--------------|--------------------------------|
| SWEEP (11,000) BOARD | | |
| C15,16,213,214 | 24G382 | CAP,RLYTIC,10UF,16V,20% |
| C25,37,60,62,126, 127,129,130,135, 199,216,217 | 24G575 | CAP,CHIP,.1UF,50V,10%,X7R |
| C27,48,54,56, 59,61,64,65, 66,69,70 | 24G465 | CAP,CHIP,.01uF,50V,10%,X7R |
| C40,197 | 24G561 | CAP,CHIP,220PF,100V,10%,NPO |
| C43 | 24G594 | CAP,CHIP,1500PF,50V,10%,X7R |
| C71-73,106,112, 114-116,192,194, 195,196,205-211 | 24G465 | CAP,CHIP,.01uF,50V,10%,X7R |
| C118-120,122,191 | 24G407 | CAP,RLYTIC,47UF,25V,+/-20% |
| C136 | 24G387 | CAP,TRIM,2.5-18PF |
| C142 | 24G637 | CAP,POLY,.0099UF,50V,1% |
| C143,218 | 24G612 | CAP,CHIP,100PF,50V,5%,NPO |
| C144 | 24G496 | CAP,MYLAR,.47UF,50V,10%,BULK |
| C145,183,215 | 24G577 | CAP,CHIP,47PF,50V,10%,NPO |
| C146 | 24G638 | CAP,POLY,10UF,50V,10% |
| C151-154 | 24G606 | CAP,CHIP,.001UF,50V,10%,X7R |
| C190 | 24G491 | CAP,RLYTIC,4.7UF,25V,+100/-20% |
| C198 | 24G384 | CAP,LYTIC,2.2UF,50V,20%, |
| C200 | 24G601 | CAP,CHIP,.047UF,50V,10%,X7R |
| C201,202 | 24G583 | CAP,CHIP,330PF,50V,5%,NPO |
| C203 | 24G584 | CAP,CHIP,82PF,50V,5%,NPO |
| C212 | 24G442 | CAP,RLYTIC,100UF,16V,+/-20% |
| C212 | 24G500 | CAP,RLYTIC,100UF,16V,20%,LOESR |
| CR5,6 | 50G35 | SMT DIODE,PIN,MMBV3401 |
| CR10-16,22-33 | 50G36 | SMT DIODE,SIL,75V,100MA,4148 |
| CR87-91,95,99-101, 108-110,113-122 124,125 | 50G36 | SMT DIODE,SIL,75V,100MA,4148 |
| CR104-106 | 50C4-6:A | DIODE,ZENER,6.2V,100mA,5%,4735 |
| CR107 | 50C3-2:A | DIODE,GERM,20V,100mA,2uA,1N695 |
| IC6 | 69G506 | IC,CONVERTER,S/P,TEA1017 |
| IC7,13,54 | 69G463 | SMTIC,OP-AMP,SINGLE,TL081 |
| IC9,10,52 | 69G450 | SMTIC,SW,TRIPLE,4053 |
| IC11 | 69G452 | SMTIC,SW,1 X 8,4051 |
| IC12 | 69G501 | SMTIC,OP-AMP,LO-PWR,324 |
| IC31 | 69G497 | SMTIC,NOR,2-IN,4001 |
| IC38,39 | 69G693 | SMTIC,8 BIT SHIFT REG,74HC4094 |
| IC40,53 | 69G429 | SMTIC,COMP,SINGLE,8PIN,LM306 |
| IC41 | 69G691 | IC,EXCLUSIVE OR/NOR,10H107 |
| IC42 | 69G132 | IC,NOR,2-IN,10H102 |
| IC44 | 69G687 | IC,J-K FLIP-FLOP,DUAL,10H135 |
| IC45 | 69G686 | IC,DUAL 4 TO 1 MTPLXR,10H174 |
| IC46 | 69G736 | SMTIC,OP-AMP,LF357M |
| IC47,48 | 69G699 | SMTIC,COMPARATOR,LM311 |
| IC49 | 69G698 | SMTIC,F-FLOP,DUAL,D,14013 |
| IC50,51 | 69G701 | SMTIC,DUAL,MULTIVIB,74HC4538 |
| IC55,56 | 69G431 | SMTIC,MUX,16PIN,4052 |
| R73-75,78,79,94, 95,589,599 | 14G102-5110A | RES,CHIP,5.11,1/8W,1%,100PPM |
| R77,159,651, 654,656 | 14G102-4991A | RES,CHIP,49.9,1/8W,1%,100PPM |
| R96,250,271,317, 388-390,583, 615,639,641 | 14G102-2433A | RES,CHIP,2.43K,1/8W,1%,100PPM |
| R99 | 14G102-3833A | RES,CHIP,3.83K,1/8W,1%,100PPM |
| R100,144,145,155, 156,437,438 | 14G102-6812A | RES,CHIP,681,1/8W,1%,100PPM |
| R100,620 | 14G102-6192A | RES,CHIP,619,1/8W,1%,100PPM |
| R103,106,625-627 | 14G102-4753A | RES,CHIP,4.75K,1/8W,1%,100PPM |
| R108,113,577 | 14G102-2216E | RES,CHIP,2.21M,1/8W,1%,500PPM |
| R110,112,424,578 | 14G102-4223A | RES,CHIP,4.22K,1/8W,1%,100PPM |
| R111,114,115,125, 126,128,232-234, 249,600-602, 644,646,665 | 14G102-1003A | RES,CHIP,1K,1/8W,1%,100PPM |
| R133-136,138,139, 220,221,223,224, 226,228,329,347, | 14G102-1004A | RES,CHIP,10K,1/8W,1%,100PPM |

**SCHEMATIC
REFERENCE**

PART NO.

DESCRIPTION

SWEEP (11,000) BOARD CONTINUED

| | | |
|--|--------------|-------------------------------|
| 429,588,629,664 | | |
| R146 | 14G102-6815A | RES,CHIP,681K,1/8W,1%,100PPM |
| R160,162,163, 208,219,628 | 14G102-6813A | RES,CHIP,6.81K,1/8W,1%,100PPM |
| R161,313 | 14G102-1214A | RES,CHIP,12.1K,1/8W,1%,100PPM |
| R170,661 | 14G102-9093A | RES,CHIP,9.09K,1/8W,1%,100PPM |
| R171,261,263, 607-609 | 14G102-1005A | RES,CHIP,100K,1/8W,1%,100PPM |
| R172 | 15G50-104 | SMT POT,VPC CERM,100K,.2W,30% |
| R173,557,657 | 14G102-7503A | RES,CHIP,7.5K,1/8W,1%,100PPM |
| R174 | 14G102-6814A | RES,CHIP,68.1K,1/8W,1%,100PPM |
| R175,177,178,180 | 14G102-5113A | RES,CHIP,5.11K,1/8W,1%,100PPM |
| R181,182,229,350, 428,573,617, 618,658 | 14G102-2673A | RES,CHIP,2.67K,1/8W,1%,100PPM |
| R188-191 | 14G102-1006A | RES,CHIP,1M,1/8W,1%,100PPM |
| R192 | 14G102-1024A | RES,CHIP,10.2K,1/8W,1%,100PPM |
| R193-195 | 14G102-4322A | RES,CHIP,432,1/8W,1%,100PPM |
| R196,197 | 14G102-2674A | RES,CHIP,26.7K,1/8W,1%,100PPM |
| R198,331,621,622 | 14G102-4754A | RES,CHIP,47.5K,1/8W,1%,100PPM |
| R199 | 14G102-8250A | RES,CHIP,8.25,1/8W,1%,100PPM |
| R200-204 | 14G102-3321A | RES,CHIP,33.2,1/8W,1%,100PPM |
| R205,206,659 | 15G50-103 | SMT POT,VPC CERM,10K,.2W,30% |
| R207,218,378, 383-385 | 14G102-3323A | RES,CHIP,3.32K,1/8W,1%,100PPM |
| R209,541,598 | 14G102-4752A | RES,CHIP,475,1/8W,1%,100PPM |
| R216,217,330,427 | 14G102-2004A | RES,CHIP,20K,1/8W,1%,100PPM |
| R251,252 | 14G102-5112A | RES,CHIP,511,1/8W,1%,100PPM |
| R266,268-270,272, 273,311,592 | 14G102-1002A | RES,CHIP,100,1/8W,1%,100PPM |
| R267,596 | 14G102-4423A | RES,CHIP,4.42K,1/8W,1%,100PPM |
| R312,374,375 | 14G102-6193A | RES,CHIP,6.19K,1/8W,1%,100PPM |
| R322 | 14G102-2002A | RES,CHIP,200,1/8W,1%,100PPM |
| R323,343,430, 603-605,610,612, 613,642,666 | 14G102-2003A | RES,CHIP,2K,1/8W,1%,100PPM |
| R326-328 | 14G102-1474A | RES,CHIP,14.7K,1.8W,1%,100PPM |
| R334 | 14G102-1503A | RES,CHIP,1.5K,1/8W,1%,100PPM |
| R335 | 14G102-4993A | RES,CHIP,4.99K,1/8W,1%,100PPM |
| R336,349 | 14G102-1822A | RES,CHIP,182,1/8W,1%,100PPM |
| R337,434 | 14G102-1433A | RES,CHIP,1.43K,1/8W,1%,100PPM |
| R342 | 14G102-3013A | RES,CHIP,3.01K,1/8W,1%,100PPM |
| R351-353 | 14G102-2213A | RES,CHIP,2.21K,1/8W,1%,100PPM |
| R361 | 14G102-1007E | RES,CHIP,10M,1/8W,1%,500PPM |
| R362,660 | 14G102-9092A | RES,CHIP,909,1/8W,1%,100PPM |
| R364,365 | 14G102-1304A | RES,CHIP,13K,1/8W,1%,100PPM |
| R366 | 15G50-102 | SMT POT,VPC CERM,1K,.2W,30% |
| R367 | 14G102-8663A | RES,CHIP,8.66K,1/8W,1%,100PPM |
| R398 | 14G102-1624A | RES,CHIP,16.2K,1/8W,1%,100PPM |
| R401 | 15G50-471 | SMT POT,VPC CERM,470,.2W,30% |
| R404 | 15G50-221 | SMT POT,VPC CERM,220,.2W,30% |
| R405,406,623, 624,645 | 14G102-2672A | RES,CHIP,267,1/8W,1%,100PPM |
| R411,638 | 14G102-2212A | RES,CHIP,221,1/8W,1%,100PPM |
| R412 | 14G102-3922A | RES,CHIP,392,1/8W,1%,100PPM |
| R413,415 | 14G102-2432A | RES,CHIP,243,1/8W,1%,100PPM |
| R416,417,640 | 14G102-5623A | RES,CHIP,5.62K,1/8W,1%,100PPM |
| R426,514-516 | 14G102-7502A | RES,CHIP,750,1/8W,1%,100PPM |
| R435,436 | 14G102-1212A | RES,CHIP,121,1/8W,1%,100PPM |
| R442,443 | 14G102-4321A | RES,CHIP,43.2,1/8W,1%,100PPM |
| R444,637 | 14G102-2215A | RES,CHIP,221K,1/8W,1%,100PPM |
| R571 | 14G102-5114A | RES,CHIP,51.1K,1/8W,1%,100PPM |
| R574,575 | 14G102-2492A | RES,CHIP,249,1/8W,1%,100PPM |
| R576 | 14G102-1103A | RES,CHIP,1.1K,1/8W,1%,100PPM |
| R584-586,597 | 14G102-8253A | RES,CHIP,8.25K,1/8W,1%,100PPM |
| R587,632 | 14G102-2214A | RES,CHIP,22.1K,1/8W,1%,100PPM |
| R593,594 | 14G102-7501A | RES,CHIP,75,1/8W,1%,100PPM |
| R630 | 14G102-4755A | RES,CHIP,475K,1/8W,1%,100PPM |
| R631 | 14G102-1504A | RES,CHIP,15K,1/8W,1%,100PPM |
| R633 | 15G50-684 | SMT POT,VPC CERM,680K,.2W,30% |
| R634-636 | 14G102-1505A | RES,CHIP,150K,1/8W,1%,100PPM |
| R653 | 14G102-2211A | RES,CHIP,22.1,1/8W,1%,100PPM |
| R662 | 14G102-9094A | RES,CHIP,90.9K,1/8W,1%,100PPM |
| R663 | 14G102-1783A | RES,CHIP,1.78K,1/8W,1%,100PPM |

6000 DIGITAL SELECT DISPLAY BOARD

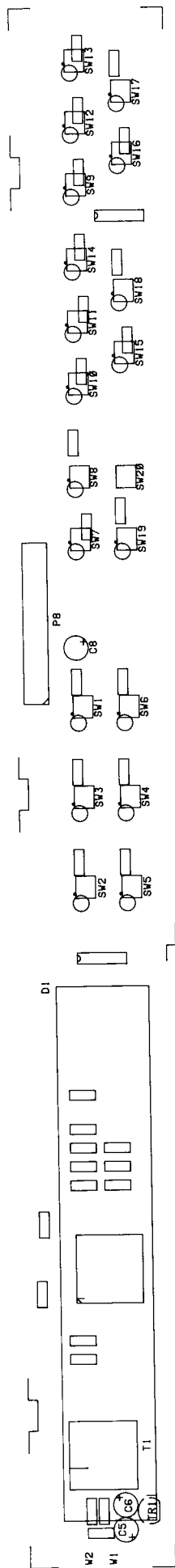

**SCHEMATIC
REFERENCE**

PART NO.

DESCRIPTION

DIGITAL SELECT/DISPLAY (6000) BOARD

| | | |
|--------|--------------|--------------------------------|
| C1-4 | 24G465 | CAP,CHIP,.01uF,50V,10%,X7R |
| C5,6 | 24G382 | CAP,LYTIC,10UF,16V,20% |
| C7 | 24G601 | CAP,CHIP,.047UF,50V,10%,X7R |
| C8 | 24G384 | CAP,LYTIC,2.2UF,50V,20% |
| C9 | 24G575 | CAP,CHIP,.1UF,50V,10%,X7R |
| CR1-19 | 20G37 | SMTLED,RED,2.2V,10MA |
| IC1 | 69G196 | SMTIC,DRIVER IC,52 PIN,UPD7225 |
| IC2 | 69G474 | SMTIC,COUNTER,DECADE,74HC4017 |
| IC3 | 69G693 | SMTIC,8 BIT SHIFT REG,74HC4094 |
| | 69G690 | IC,VOLTAGE REG,12V,1.5A |
| | 69G277 | IC,REG,+5V,500mA,LM340-5 |
| R1,2 | 14G102-1825A | RES,CHIP,182K,1/8W,1%,100PPM |
| R3-5 | 14G102-4753A | RES,CHIP,4.75K,1/8W,1%,100PPM |
| R6-24 | 14G102-4752A | RES,CHIP,475,1/8W,1%,100PPM |
| R25 | 14G102-1001A | RES,CHIP,10,1/8W,1%,100PPM |
| R26 | 14G102-3324A | RES,CHIP,33.2K,1/8W,1%,100PPM |
| R27 | 14G102-8251A | RES,CHIP,82.5,1/8W,1%,100PPM |
| R28 | 15G50-221 | SMT,POT,VPC CERM,220,.2W,30% |
| R29 | 14G102-1003A | RES,CHIP,1K,1/8W,1%,100PPM |
| T1 | 28G121 | TRANSFORMER,EL BACKLIGHT |
| TR1 | 19A44 | TRANS,NPN,40V,600mA,,2N4401 |
| SW1-20 | 25B417-1 | SWITCH PAD, DIGITAL SELECT |
| | 44G12 | FUSE,FASTBLOW 3AG,2A,250V |
| | 44G32 | FUSE,FASTBLOW,3AG,1/8A,250V |
| | 44G20 | FUSE,SLOWBLOW 3AG,1AMP,250V,, |

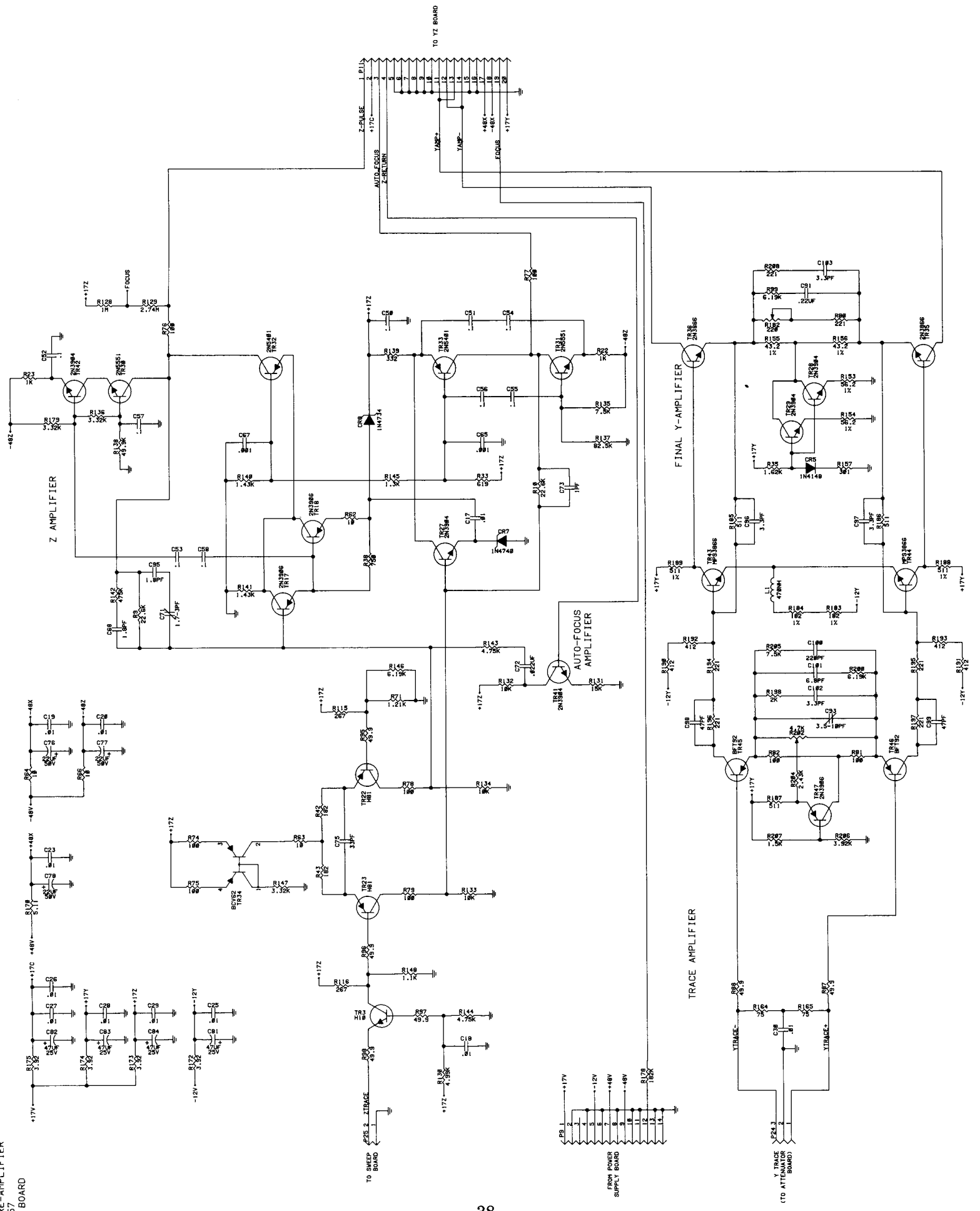

2000 YZ PREAMP

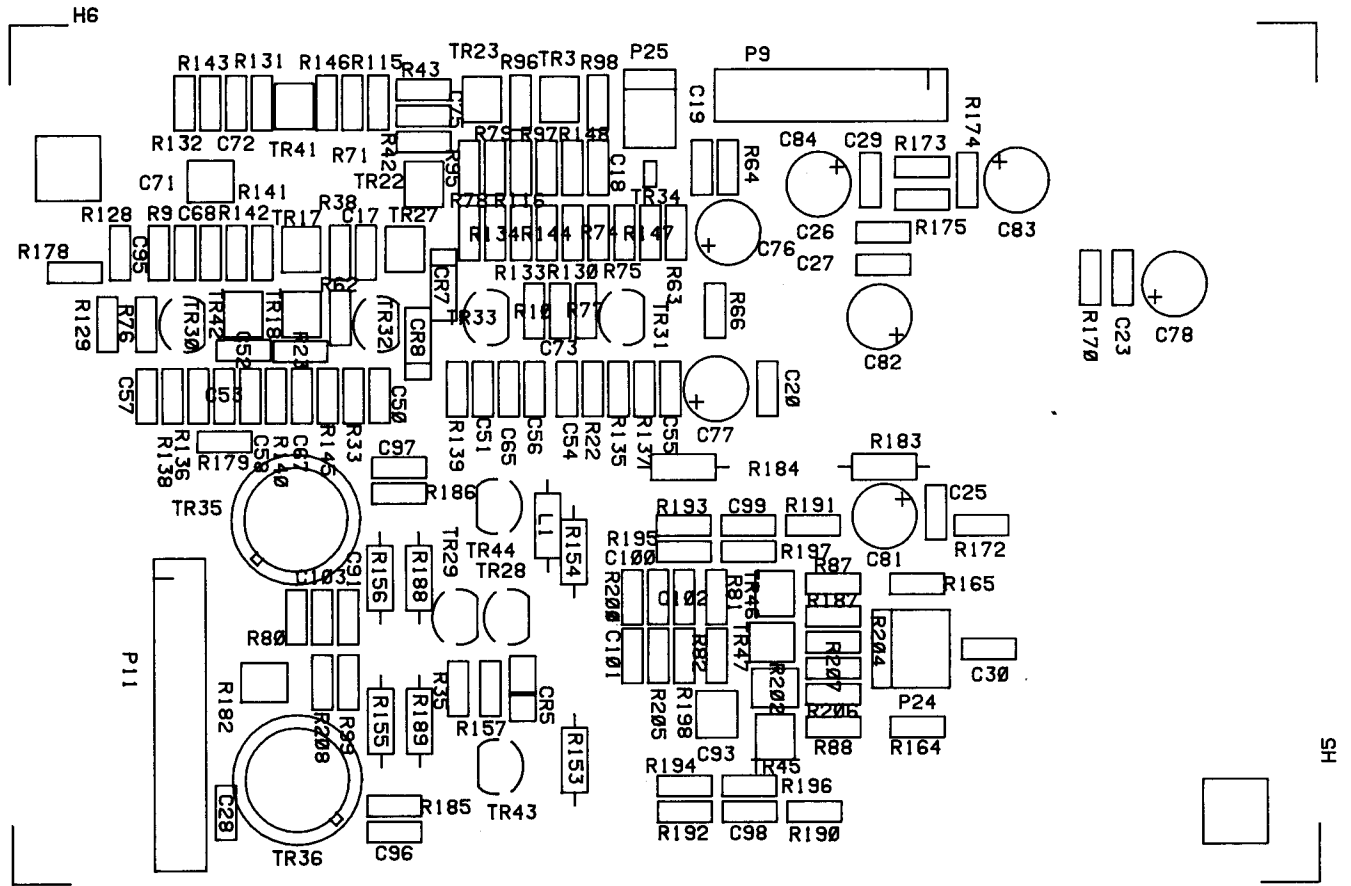

**SCHEMATIC
REFERENCE**

PART NO.

DESCRIPTION

YZ PREAMP (2000) BOARD

| | | |
|-----------------|--------|------------------------------|
| C17-20,23,25-30 | 24G465 | CAP,CHIP,.01uF,50V,10%,X7R |
| C50-58 | 24G575 | CAP,CHIP,.1UF,50V,10%,X7R |
| C65,67 | 24G606 | CAP,CHIP,.001UF,50V,10%,X7R |
| C68,95 | 24G630 | CAP,CHIP,1.8PF,50V,.25PF,NPO |
| C71 | 24G676 | CAP,TRIM,1.7-3.0PF,100V |
| C72 | 24G618 | CAP,CHIP,.022UF,50V,10%,X7R |
| C73 | 24G629 | CAP,CHIP,1PF,50V,.25PF,NPO |
| C75 | 24G615 | CAP,CHIP,33PF,50V,5%,NPO |
| C76-78 | 24G451 | CAP,RLYTIC,22UF,50V,20% |

**SCHEMATIC
REFERENCE**

PART NO.

DESCRIPTION

YZ PREAMP (2000) BOARD CONTINUED

| | | |
|-----------------|--------------|--------------------------------|
| C81-84 | 24G407 | CAP,RLYTIC,47UF,25V,+/-20% |
| C91 | 24G624 | CAP,CHIP,.22UF,50V,+80/-20,Y5V |
| C93,102 | 24G677 | CAP,TRIM,3.5-10pF,100V |
| C96,97,102,103 | 24G611 | CAP,CHIP,3.3PF,50V,.25PF,NPO |
| C98,99 | 24G577 | CAP,CHIP,47PF,50V,10%,NPO |
| C100 | 24G561 | CAP,CHIP,220PF,100V,10%,NPO |
| C101 | 24Z599 | CAP,CHIP,6.8PF,50V,.25PF,NPO |
| CR5 | 50G36 | SMT DIODE,SIL,75V,100MA,4148 |
| CR7 | 50C4-12 | DIODE,ZENER,10V,95mA,10%,4740 |
| CR8 | 50C4-14 | DIODE,ZENER,5.6V,162mA,5%,4734 |
| L1 | 46Z190 | IND,.47UH,10% |
| R9,10 | 14G102-2264A | RES,CHIP,22.6K,1/8W,1% |
| R22,23 | 14G102-1003A | RES,CHIP,1K,1/8W,1%,100PPM |
| R33 | 14G102-6192A | RES,CHIP,619,1/8W,1%,100PPM |
| R35 | 14G102-1623A | RES,CHIP,1.62K,1/8W,1%,100PPM |
| R38 | 14G102-7502A | RES,CHIP,750,1/8W,1%,100PPM |
| R42,43 | 14G102-1822A | RES,CHIP,182,1/8W,1%,100PPM |
| R62-64,66 | 14G102-1001A | RES,CHIP,10,1/8W,1%,100PPM |
| R71 | 14G102-1213A | RES,CHIP,1.21K,1/8W,1%,100PPM |
| R74-79,81,82 | 14G102-1002A | RES,CHIP,100,1/8W,1%,100PPM |
| R80,194-197,208 | 14G102-2212A | RES,CHIP,221,1/8W,1%,100PPM |
| R87,88,95-98 | 14G102-4991A | RES,CHIP,49.9,1/8W,1%,100PPM |
| R99,146,200 | 14G102-6193A | RES,CHIP,6.19K,1/8W,1%,100PPM |
| R115,116 | 14G102-2672A | RES,CHIP,267,1/8W,1%,100PPM |
| R128 | 14G102-1006A | RES,CHIP,1M,1/8W,1%,100PPM |
| R129 | 14G102-2746E | RES,CHIP,2.74M,1/8W,1%,500PPM |
| R130 | 14G102-4993A | RES,CHIP,4.99K,1/8W,1%,100PPM |
| R131 | 14G102-1504A | RES,CHIP,15K,1/8W,1%,100PPM |
| R132-134 | 14G102-1004A | RES,CHIP,10K,1/8W,1%,100PPM |
| R135,205 | 14G102-7503A | RES,CHIP,7.5K,1/8W,1%,100PPM |
| R136,147,179 | 14G102-3323A | RES,CHIP,3.32K,1/8W,1%,100PPM |
| R137 | 14G102-8254A | RES,CHIP,82.5K,1/8W,1%,100PPM |
| R138 | 14G102-4994A | RES,CHIP,49.9K,1/8W,1%,100PPM |
| R139 | 14G102-3322A | RES,CHIP,332,1/8W,1%,100PPM |
| R140,141 | 14G102-1433A | RES,CHIP,1.43K,1/8W,1%,100PPM |
| R142 | 14G102-4755A | RES,CHIP,475K,1/8W,1%,100PPM |
| R143,144 | 14G102-4753A | RES,CHIP,4.75K,1/8W,1%,100PPM |
| R145 | 14G102-1303A | RES,CHIP,1.3K,1/8W,1%,100PPM |
| R148 | 14G102-1103A | RES,CHIP,1.1K,1/8W,1%,100PPM |
| R153,154 | 14A38-5621A | RES,MET.F,56.2,1/4W,1%,100PPM |
| R155,156 | 14A38-4321A | RES,MET.F,43.2,1/4W,1%,100PPM |
| R157 | 14G102-3012A | RES,CHIP,301,1/8W,1%,100PPM |
| R164,165 | 14G102-7501A | RES,CHIP,75,1/8W,1%,100PPM |
| R170 | 14G102-5110A | RES,CHIP,5.11,1/8W,1%,100PPM |
| R172-175 | 14G102-3920A | RES,CHIP,3.92,1/8W,1%,100PPM |
| R178 | 14G102-1825A | RES,CHIP,182K,1/8W,1%,100PPM |
| R182 | 15G50-221 | SMT,POT,VPC CERM,220,.2W,30% |
| R183,184 | 14A38-1822A | RES,MET.F,182,1/4W,1%,100PPM |
| R185-187 | 14G102-5112A | RES,CHIP,511,1/8W,1%,100PPM |
| R188,189 | 14A38-5112A | RES,MET.F,511,1/4W,1%,100PPM |
| R190-193 | 14G102-4122A | RES,CHIP,412,1/8W,1%,100PPM |
| R198 | 14G102-2003A | RES,CHIP,2K,1/8W,1%,100PPM |
| R202 | 15G50-472 | SMT POT,VPC CERM,4.7K,.2W,30% |
| R204 | 14G102-2433A | RES,CHIP,2.43K,1/8W,1%,100PPM |
| R205 | 14G102-2673A | RES,CHIP,2.67K,1/8W,1%,100PPM |
| R206 | 14G102-3923A | RES,CHIP,3.92K,1/8W,1%,100PPM |
| R207 | 14G102-1503A | RES,CHIP,1.5K,1/8W,1%,100PPM |
| TR3 | 19G98 | SMT TRANS,VHF/UHF AMP,MMBTH10 |
| TR17,18,47 | 19G95 | SMT TRANS,PNP,40V,200MA,3906 |
| TR22,23 | 19G113 | SMTTRANS,PNP,600MHZ,MMBTH81L |
| TR27,41,42 | 19G92 | SMT TRANSISTOR,NPN,3904,SOT23 |
| TR28,29 | 19A33-1 | TRANS,NPN,40V,200mA,2N3904 |
| TR30,31 | 19G103 | TRANS,NPN,160V,600MA,2N5551 |
| TR32,33 | 19A32 | TRANSISTOR,PNP,2N5401 |
| TR34 | 69G547 | SMTIC,MATCHED PNP TRANS,BCV62 |
| TR35,36 | 19A13-1 | TRANS,NPN,30V,400mA,,2N3866 |
| TR43,44 | 19G66 | TRANS,NPN,30V,400mA,,MPS3866 |
| TR45,46 | 19G102 | SMT TRANS,PNP,15V,25MA,BFT92 |
| | 28B124 | TRANSFORMER,POWER,SC3100 |

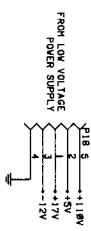
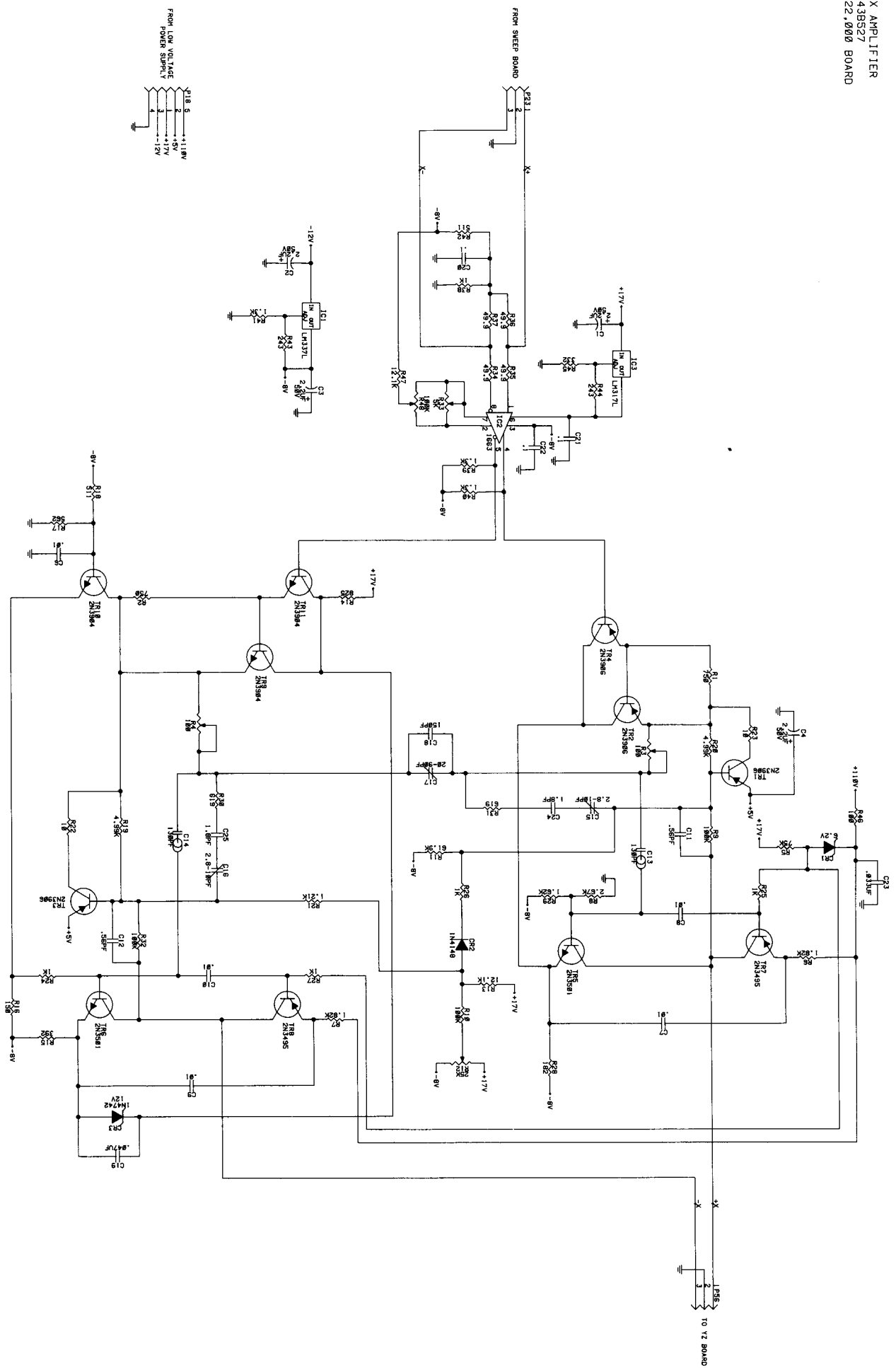

22,000 X-AMP BOARD

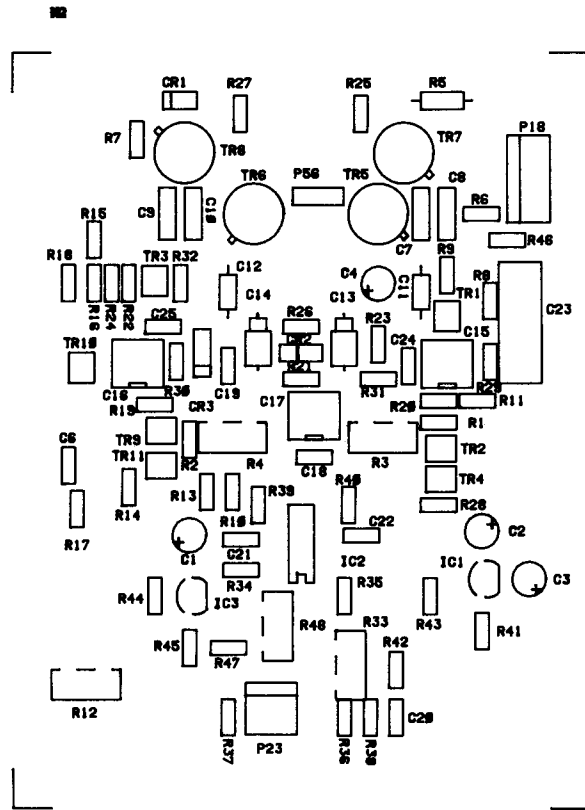

SCHEMATIC REFERENCE

PART NO.

DESCRIPTION

X-AMP (22,000) BOARD

| | | |
|----------|--------------|--------------------------------|
| C1-4 | 24G384 | CAP,LYTIC,2.2UF,50V,20%, |
| C6 | 24G465 | CAP,CHIP,.01uF,50V,10%,X7R |
| C7-10 | 24G126 | CAP,DISC,.01UF,200V,20%,Z5U |
| C11,12 | 24G322 | CAP,DISC,.56PF,500V,10% |
| C13,14 | 24G71 | CAP,DISC,130PF,500V,10%,NPO |
| C15,16 | 24G693 | CAP,TRIM,2.8-10PF,100V,10% |
| C17 | 24G692 | CAP,TRIM,20-90PF,100V,10% |
| C18 | 24G582 | CAP,CHIP,150PF,50V,5%,NPO |
| C19 | 24G601 | CAP,CHIP,.047UF,50V,10%,X7R |
| C20-22 | 24G575 | CAP,CHIP,.1UF,50V,10%,X7R |
| C23 | 24G404 | CAP,POLYPROP,.033uF,200V,10% |
| C25,24 | 24G630 | CAP,CHIP,1.8PF,50V,.25PF,NPO |
| CR1 | 50C4-6:A | DIODE,ZENER,6.2V,100mA,5%,4735 |
| CR2 | 50G36 | SMT DIODE,SIL,75V,100MA,4148 |
| CR3 | 50C4-17 | DIODE,ZENER,12V,76mA,5%,IN4742 |
| IC1 | 69G288 | IC,REG,ADJ,NEG,LM337 |
| IC2 | 69G729 | IC,AMP,DIFF,WIDEBAND,1663 |
| IC3 | 69G231 | IC,REG,ADJ,POS,LM317 |
| L13,14 | 46G88 | IND,FERRITE BEAD |
| R1,2 | 14G102-7502A | RES,CHIP,750,1/8W,1%,100PPM |
| R3,4 | 15G65-101 | POT,VPC,CERM,100,1/2W,20% |
| R5 | 14C1-753 | RES,CARBON,75K,1/4W,5% |
| R6,7 | 14G102-1823A | RES,CHIP,1.82K,1/8W,1%,100PPM |
| R8 | 14G102-2673A | RES,CHIP,2.67K,1/8W,1%,100PPM |
| R9,10,32 | 14G102-1005A | RES,CHIP,100K,1/8W,1%,100PPM |
| R11 | 14G102-6194A | RES,CHIP,61.9K,1/8W,1%,100PPM |
| R12 | 15C26-33 | POT,MHPC CERM,25K,1/2W,20% |
| R13,47 | 14G102-1214A | RES,CHIP,12.1K,1/8W,1%,100PPM |
| R14 | 14G102-8252A | RES,CHIP,825,1/8W,1%,100PPM |
| R15 | 14G102-3922A | RES,CHIP,392,1/8W,1%,100PPM |
| R16 | 14G102-1502A | RES,CHIP,150,1/8W,1%,100PPM |
| R17 | 14G102-5622A | RES,CHIP,562,1/8W,1%,100PPM |
| R18,42 | 14G102-5112A | RES,CHIP,511,1/8W,1%,100PPM |
| R19,20 | 14G102-4993A | RES,CHIP,4.99K,1/8W,1%,100PPM |

**SCHEMATIC
REFERENCE****PART NO.****DESCRIPTION****X-AMP (22,000) BOARD CONTINUED**

| | | |
|-----------|--------------|-------------------------------|
| R21 | 14G102-1213A | RES,CHIP,1.21K,1/8W,1%,100PPM |
| R22,23 | 14G102-1001A | RES,CHIP,10,1/8W,1%,100PPM |
| R24-27,38 | 14G102-1003A | RES,CHIP,1K,1/8W,1%,100PPM |
| R28 | 14G102-1822A | RES,CHIP,182,1/8W,1%,100PPM |
| R29 | 14G102-1623A | RES,CHIP,1.62K,1/8W,1%,100PPM |
| R30,31 | 14G102-6192A | RES,CHIP,619,1/8W,1%,100PPM |
| R33 | 15C26-32 | POT,MHPC CERM,5K,1/2W,20% |
| R34-37 | 14G102-4991A | RES,CHIP,49.9,1/8W,1%,100PPM |
| R39-41 | 14G102-1303A | RES,CHIP,1.3K,1/8W,1%,100PPM |
| R43,44 | 14G102-2432A | RES,CHIP,243,1/8W,1%,100PPM |
| R45 | 14G102-3322A | RES,CHIP,332,1/8W,1%,100PPM |
| R46 | 14G102-1002A | RES,CHIP,100,1/8W,1%,100PPM |
| R48 | 15C26-14 | POT,MVPC CERM,100K,1/2W,20% |
| TR1-4 | 19G95 | SMT TRANS,PNP,40V,200MA,3906 |
| TR5,6 | 19G138 | TRANS,NPN,150V,300MA,2N3501 |
| TR7,8 | 19G137 | TRANS,PNP,120V,100MA,2N3495 |
| TR9-11 | 19G92 | SMT TRANSISTOR,NPN,3904,SOT23 |

 **WARNING****Avoid damage to parts caused by static electricity!**

Most solid-state devices and film resistors are susceptible to damage due to discharge of electricity. Observe the following precautions when a PC board is removed from the unit, or when handling components:

1. The person handling the part must be grounded through a 1 megohm resistor via a wrist strap or similar ground collection.
2. A PC board or component should never be placed on an insulated surface. The surface must be ground (through a 1 megohm resistor) and conductive.
3. All replacement parts must be left in a completely enclosed, conductive container or package until ready for use. The person removing the part from the container must be properly grounded. All parts susceptible to static damage are shipped in conductive containers when ordered from the Sencore Service Department.

Components not listed are standard replacement parts and may be purchased locally. When ordering parts, please specify instrument model number, schematic reference, part number, and description. Please include remittance (check or money order) with your order, otherwise invoice will be shipped C.O.D. Minimum billing is \$5.00.

**TOLL FREE 1-800-SENCORE****SENCORE**3200 Sencore Drive
Sioux Falls, SD 57107*innovatively designed
with your time in mind.*