



Declaration on Taximeter Output using the Model 3/Y Third-Party CAN Bus Interface

Tesla Spain SL Unipersonal declares that the vehicle, make Tesla, type 003, variant _____, version _____, commercial name Model 3 Model Y with type approval No. _____ and with chassis number _____ has a tachymeter output for speed and distance, taking the signal from the X181 connector as described on page 2 and 3 of this document.

This signal is the only appropriate one for the correct operation of the taximeter; it provides the maximum metrological accuracy since this signal corresponds to the signal of the sensor on the drive unit. Also, it does not affect vehicle safety, all according to Order ICT/155/2020, in its annex VII, appendix III, point 1.

 **NOTE:** For the fields “variant”, “version” and “type approval No.”, see the ‘Certificate Of Conformity’ which is part of the vehicle documentation.

Signed by : _____

Job title : _____

Date : _____

Tesla Service Centre ID : _____



Model 3 / Model Y Third-Party CAN Bus Interface

Certain Model 3 and Model Y vehicles are configured with a third-party CAN bus on connector X181 as follows:

- Model 3 produced from January 5, 2019 onwards (CAN bus is functional only with firmware version 2020.36 or later)
- Model Y (VIN starting with 5YJ) produced from January 13, 2021 onwards
- Model Y (VIN starting with LRW) produced from December 14, 2020 onwards
- Model Y (VIN starting with XP7) as from start of production onwards

Disclaimer

Connecting or hard-wiring non-Tesla or third-party accessories or equipment into existing Tesla vehicle electrical systems is not supported by Tesla, and the installer performs this modification at their own risk. Installed unapproved equipment is not covered by any Tesla warranty, and is considered a non-standard modification of the vehicle.

⚠ CAUTION: Installing unapproved components might be detrimental and incur damage to the vehicle. Tesla employees are not permitted to install or assist in the installation of any non-Tesla component. Service to rectify any damage caused by the installation of unapproved components is not covered by any warranty.

📄 NOTE: Installing unapproved components might affect the serviceability of the vehicle. Tesla employees are not permitted to service any non-Tesla component. Should the vehicle require service of a Tesla system which has been modified, such service is regarded as Modified Service. Modified Service requires a signed [SC-18-00-008](#), "Authorization and Release for Modified Service", and may not be covered by any warranty. Tesla is not responsible for any damage incurred to an unapproved component while performing a Modified Service.

⚠ WARNING: Modifications can affect vehicle performance and behavior, and might compromise vehicle safety. Tesla does not guarantee the usability, functionality, or reliability of the modification, nor will Tesla bear any responsibility to the consequences of the modification.

Third-Party CAN Bus Connector Location

Connector X181 is an SAE J1962 connector located under the LH side of the instrument panel (Figure 1), and is accessed by removing the LH footwell cover.

 **NOTE:** Depending on vehicle configuration, the connector may be accessible without removing the LH footwell cover.

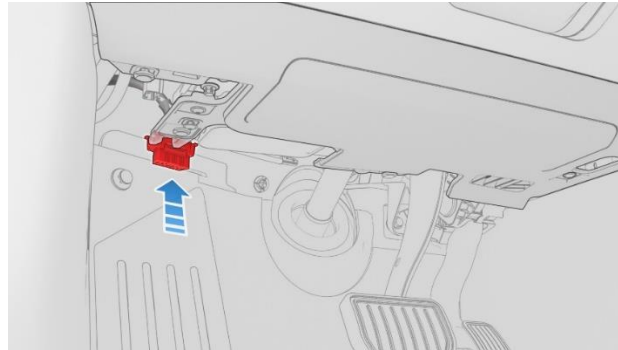
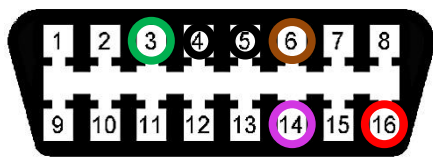



Figure 1 – Location of connector X181

Connector X181 Pinout and Considerations

The SAE J1962 connector offers a third-party CAN bus interface on Pin 6 and Pin 14. Additionally, chassis ground is available on Pin 4 and Pin 5, and 12V+ / Low Voltage+ is available on Pin 3 and Pin 16.

	Pin 3	ACCESSORY_FEED_2 – 12V+ / Low Voltage+
	Pin 4	GND
	Pin 5	GND
	Pin 6	CAN HIGH - 500 kbps
	Pin 14	CAN LOW - 500 kbps
	Pin 16	ACCESSORY_FEED_1 – 12V+ / Low Voltage+

The device connected to connector X181 is powered while the vehicle is awake through Pin 16 (ACCESSORY_FEED_1) or Pin 3 (ACCESSORY_FEED_2), either of which can provide up to 1000 mA continuous.

 **CAUTION:** Do not splice Pin 3 (ACCESSORY_FEED_2) and Pin 16 (ACCESSORY_FEED_1) together. If greater current capacity is required, refer to [CD-19-17-001](#), “Model 3/Y 12V Power Circuit for Third-Party Accessories, First Generation Center Console” or [CD-20-17-002](#), “Model 3/Y 12V Power Circuit for Third-Party Accessories, Second Generation Center Console”.

 **NOTE:** When the vehicle wakes up, Pin 3 (ACCESSORY_FEED_2) and Pin 16 (ACCESSORY_FEED_1) power on simultaneously. When the vehicle goes to sleep, Pin 3 (ACCESSORY_FEED_2) powers off, 10 seconds later, Pin 16 (ACCESSORY_FEED_1) powers off.