

Model: All

Vehicle System: 19 - Labels

Region: All

Tech Note: Ordering Replacement Manufacturing Certification and Tire Information Labels

Tech Notes are announcements that help to communicate and track new information about Tesla Service concerns. Such concerns may or may not be VIN specific. These instructions assume knowledge of motor vehicle and high voltage electricity repairs, and should only be executed by trained professionals. Tesla Motors assumes no liability for injury or property damage due to a failure to properly follow these instructions or for repairs attempted by unqualified individuals.

Some labels on Model S and Roadster are unique to the individual vehicle. For Model S, the manufacturing certification label and tire information label are unique. For Roadster, only the manufacturing certification label is unique; the tire information label is not unique to the individual vehicle.

Unique labels are intended to be permanent and legible throughout their life. As a result, these labels should be replaced only in the event of extraordinary circumstances (e.g., collision damage that makes the label otherwise unreadable).

NOTE: Depending on the region, the manufacturing certification label may also be known as the vehicle certification label, statutory plate, product plate, or identification plate. The tire information label may also be known as the tire identification placard.

If a replacement label is needed, specific information is required during the ordering process so that the label is printed correctly and Tesla complies with regulatory requirements.

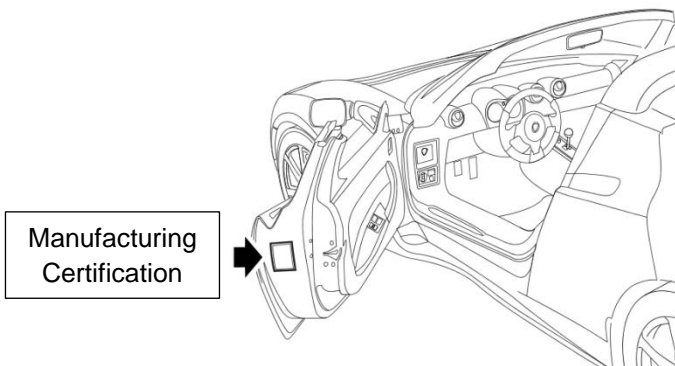

Figure 1 (Roadster)

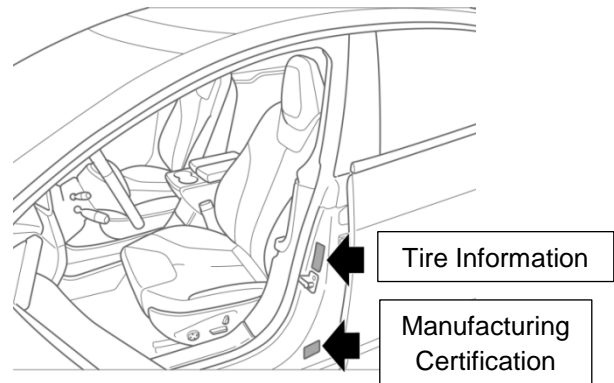

Figure 2 (Model S)

Ordering Procedure

1. Record the following information from the vehicle:

Model S:

- The reason that a new label is needed
- Complete VIN
- The country where the vehicle was originally delivered
- Battery capacity
- Suspension type (coil spring, air spring, performance plus)
- Wheel type (base, aero, cyclone, etc.)
- Wheel color
- Tire size(s) and brand

NOTE: List the wheel and tire information for the original equipment wheels and tires, not winter or aftermarket wheels/tires.

Roadster:

- The reason that a new label is needed
- Complete VIN
- The country where the vehicle was originally delivered
- Month and year of manufacture

2. Take a clear picture of the original label.

3. Take a clear picture of the VIN plate (visible through the lower LH corner of the windshield).

4. Take a clear picture of one of the wheels (Model S original equipment wheels only).

5. Submit the necessary information:

Tesla Approved Collision Repair Centers: Send the 3 pictures and all of the information from step 1 to collision-parts@teslamotors.com.

Tesla Service Centers: Send the 3 pictures and all of the information from step 1 to VINspecificparts@teslamotors.com. Additionally, include all of the information from step 1 in the part request notes in Warp Service.

NOTE: Custom labels require 5-7 business days in addition to the normal order processing time.

For feedback on the accuracy of this document, email ServiceBulletinFeedback@teslamotors.com.