

TN-18-16-001 R2 December 15, 2021		Tesla, Inc. Technical Note
<b>Model:</b>	<b>Vehicle System:</b>	<b>Region:</b>
Model 3 Model Y	16 - Battery System	All

## Inspect the Model 3 and Model Y HV Battery for Underside Damage

*Tech Notes are announcements that help to communicate and track new information about Tesla Service concerns. Such concerns may or may not be VIN specific. These instructions assume knowledge of motor vehicle and high voltage electrical component repairs, and should only be executed by trained professionals. Tesla assumes no liability for injury or property damage due to a failure to properly follow these instructions or for repairs attempted by unqualified individuals.*

*This Tech Note supersedes TN-18-16-001 R1, dated 12-Jun-20. Each content change is marked by a vertical line in the left margin. Discard the previous version and replace it with this one.*

Whenever the vehicle is raised, or if the customer has indicated possible damage, the underside of the vehicle, including the High Voltage (HV) battery, should be visually inspected for damage. HV battery damage may include:

- Dents, holes, cracks, or tears
- Corrosion or moisture accumulation
- Evidence of a previous thermal event, such as smoke residue, discoloration, deformation, melted seals, metallic platter, or abnormal odor
- Rupture or disassembly
- Coolant or electrolyte leakage

 **NOTE:** If a vehicle is brought into a Body Shop with visible damage to the bottom of the HV battery, the Body Shop should contact Tesla:

- **In Europe, Middle East, and Africa:** Contact [EMEABodyRepair@Tesla.com](mailto:EMEABodyRepair@Tesla.com).
- **All other regions:** Contact your local Tesla Service Center.

The Body Shop should not try to repair the HV battery damage. Only Tesla Service Centers should try to repair the damaged HV battery.

**⚠ WARNING:** If the HV battery enclosure is compromised with a **visible open hole, crack, or tear** (Figures 1 and 2), the Service Center should not perform any additional inspections, and recommend the customer replace the HV battery. No further diagnosis is needed as Tesla recommends an HV battery replacement for any visible open hole, crack, or tear to meet Tesla's standards of quality and safety.



**Figure 1 – Visible open hole**



**Figure 2 – Visible open crack**

**☰ NOTE:** If at any point during the inspection the damage requires a HV battery, advise the customer that the HV battery requires replacement to meet Tesla's standards of quality and safety. Tesla does not recommend driving the vehicle until the HV battery is replaced. Since the new HV battery replacement is not covered under the vehicle warranty, the Service Center should recommend that the customer replace the HV battery and provide the customer a price quote for the HV battery replacement. The warranty does not cover the HV battery damage because it was caused by an external impact.

**☰ NOTE:** If a replacement HV battery is recommended for any out of warranty repair and the customer declines the repair, refer to [Article 6101300](#) for the appropriate next actions.

**⚠ WARNING:** Failure to follow all High Voltage (HV) safety precautions, including the use of personal protective equipment, when working on or around HV components may result in serious injury or property damage. Only technicians who have completed Tesla's Mechanical, Electrical, and Trim training course should diagnose, repair, or replace HV components. In addition, all repair and operating instructions should be reviewed and understood before working on Tesla vehicles or associated repair equipment.

**⚠ WARNING:** An HV battery poses a significant high voltage and electrocution risk if the outer enclosure or safety circuits have been compromised or have been significantly damaged. Proper Personal Protective Equipment (PPE) and insulating HV gloves with a minimum rating of class 0 (1000V) must be worn any time a high voltage component is handled. Refer to Technical Note [TN-15-92-003](#), "High Voltage Awareness Care Points" for additional safety information.

**⚠ WARNING:** If the HV battery or vehicle displays signs of escaping gases, smoke, flames, excessive heat, sparks, or arcing, contact the local emergency department and refer to the Emergency Response Guide, available at <http://www.tesla.com/firstresponders> and/or [TN-13-16-007](#), "Lithium-Ion Battery Emergency Response Guide, Model S, X, 3, and Y". Gases or smoke exiting a lithium-ion HV battery are likely flammable and could ignite at any time.

**⚠ WARNING:** Avoid contact with gases escaping from the HV battery. Vented gases might irritate the eyes, skin, and throat. Vent gas temperatures can exceed 600°C (1,110°F). Contact with hot gases can cause burns.

**⚠ WARNING:**

- Inspect or repair a vehicle that has an unstable battery outdoors or within easy access to the outdoors.
- If an HV battery has been determined to have a coolant leak, do not pressurize the cooling system.
- Store damaged HV batteries at least 15 m (50 ft) away from flammable materials, structures, other vehicles, and other HV batteries.
- Do not store standalone HV batteries below  $-20^{\circ}\text{C}$  ( $-4^{\circ}\text{F}$ ).
- Do not store standalone HV batteries for over 10 days above  $35^{\circ}\text{C}$  ( $95^{\circ}\text{F}$ ).
- Do not charge or discharge a standalone HV battery below  $0^{\circ}\text{C}$  ( $32^{\circ}\text{F}$ ).
- Do not store standalone HV batteries for over 30 days at full state of charge (SOC) or completely discharged.
- Do not charge a damaged or potentially unstable HV battery.
- Do not weld near HV batteries.

## HV Battery Assembly Underside

The underside of the HV battery assembly has several key components, as shown in Figure 3.

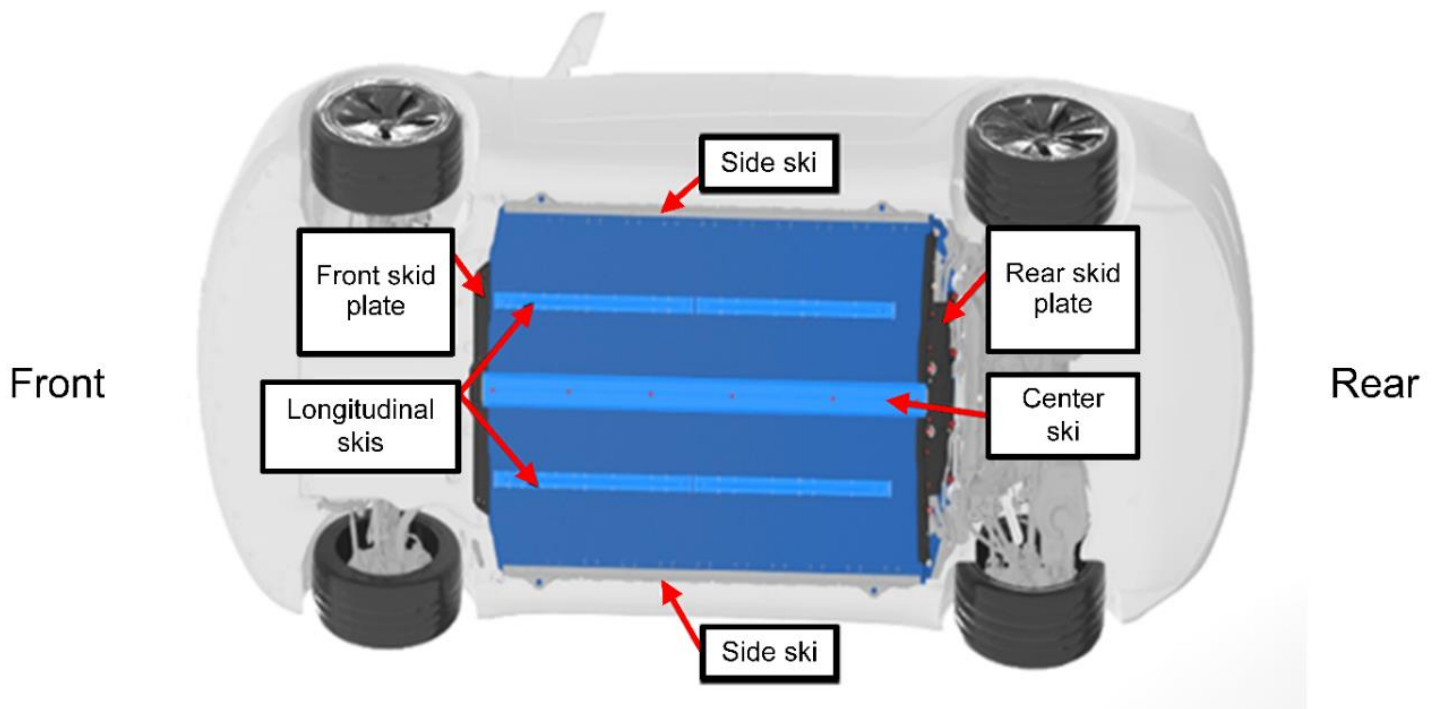

Figure 3 – HV battery assembly components

The bottom of the HV battery assembly can be divided into a grid to make it easier to track and report damage (Figure 4).



Figure 4 – HV battery grid layout

The grid locations for the underside components of the HV battery assembly are shown in Figure 5.

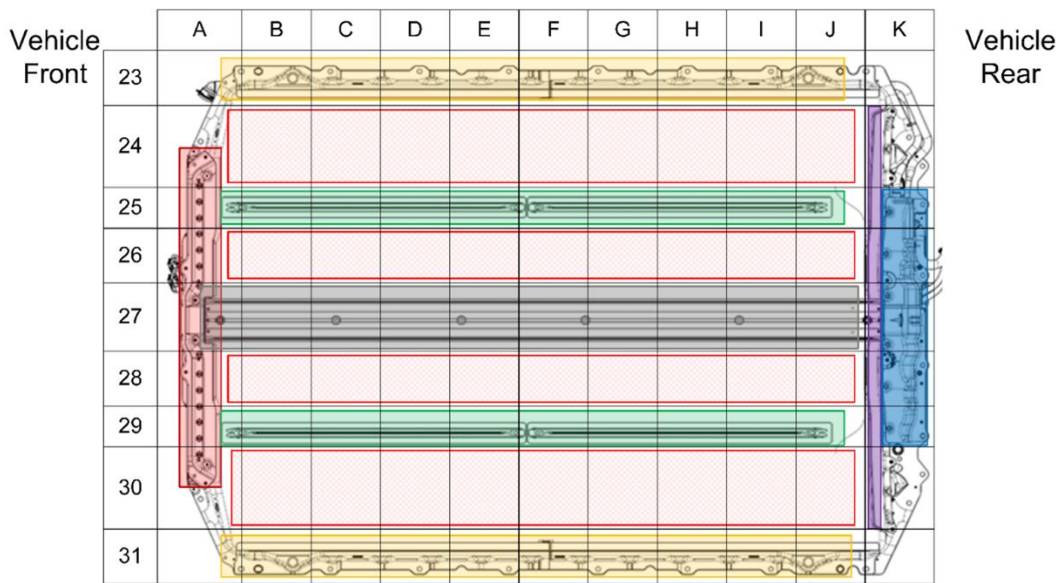

- 1
- 2
- 3
- 4
- 5
- 6
- 7

	HV Battery Assembly Part	Grid Locations
1	Front skid plate	A24 – A30
2	Side ski zones	A23 – J23, A31 – J31
3	Longitudinal skis	A25 – J25, A29 – J29
4	Center ski	A27 – J27
5	Baseplate:	A24 – J24, A26 – J26, A28 – J28, A30 – J30
6	Rear skid plate bracket	K24 – K30
7	Rear skid plate	K25 – K29

**Figure 5 – HV battery bottom grid**

The grid locations for the front and rear edges of the HV battery assembly are shown in Figure 6.



	HV Battery Assembly Part	Grid Locations
1	Front skid plate	A3 – A7
2	Front base plate	A1 – A2, A4 – A6, A8 – A9
3	Rear skid plate bracket	K33 – K38
4	Rear skid plate	K34 – K37

**Figure 6 – HV battery edge grid**

If there is noticeable damage to the bottom of the HV battery assembly:

1. Create a Toolbox session with [Article 37566](#) marked as an issue.
2. Add the comment “@NACompromisedBattery”, “@EUCompromisedBattery”, or “@APACCompromisedBattery”, depending on your region,” to add HV battery inspection engineers as watchers.

3. Collect the following information and upload it to the session:
  - a. Several pictures of the damage, taken with a high-resolution camera: If there isn't a visible open hole, crack, or tear, measure the depth of the HV battery enclosure damage (Figure 7) **while wearing proper PPE**. If the damage is not obvious, take an overall picture of the HV battery, with pointers to the damaged area or areas.

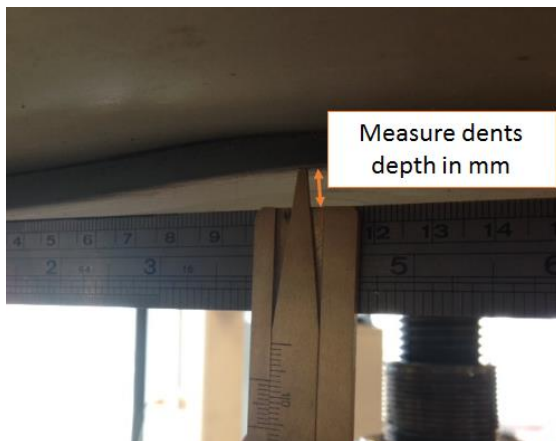
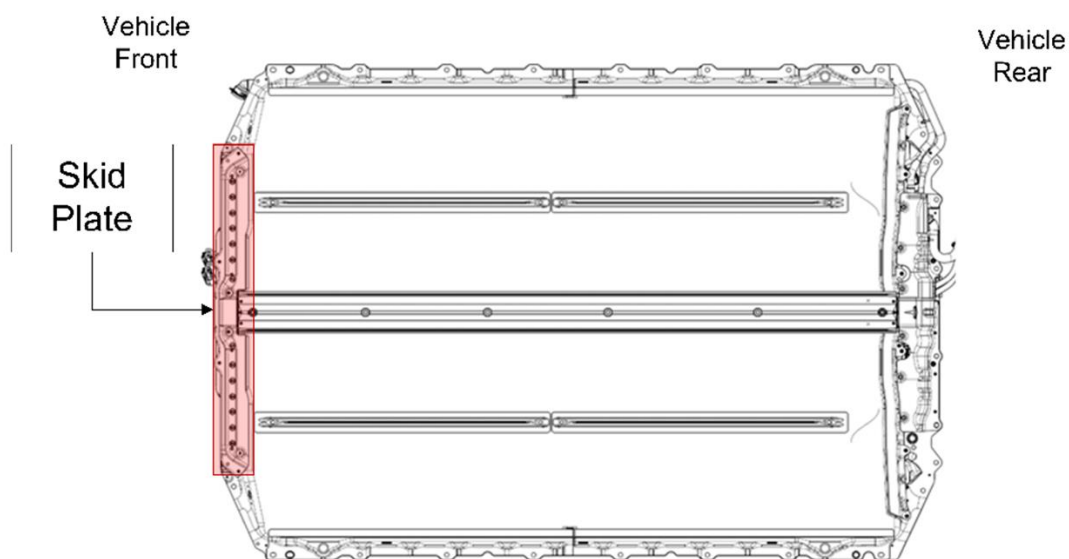

**Figure 7 – Measuring the depth of enclosure damage**

- b. Information from the customer about the incident that may have caused the damage, if available.
  - c. The location of the damage according to the specific zone.
4. Perform the appropriate repair according to the corresponding zone below.

## Front Skid Plate

The front skid plate is located at the front of the HV battery, as shown in Figure 8:



**Figure 8 – Front skid plate location**

To inspect the front skid plate for damage:

1. Visually inspect the front skid plate for tears, dents, or breaches (Figure 9).

 **NOTE:** Replace the front skid plate if it does not cover front baseplate or its leading edge is dented, torn, or breached.



**Figure 9 – Torn front skid plate**

2. Remove the front skid plate (Figure 10) (refer to Service Manual procedure 16102002).

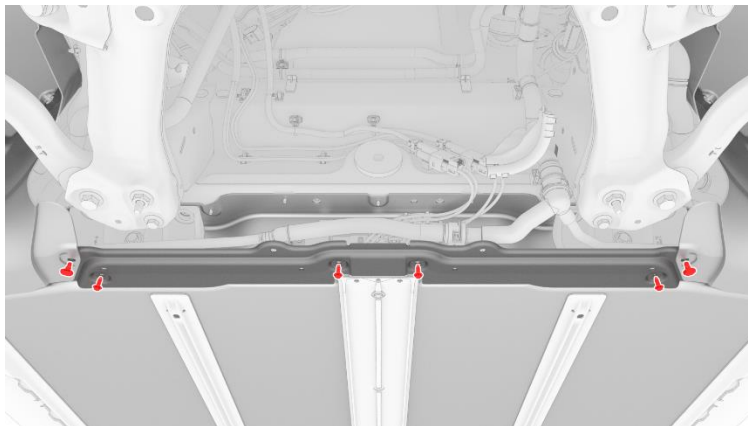

**Figure 10 – Skid plate bolts**

3. Inspect the HV cables and passthroughs.
4. If there is damage to the leading edge above the front skid plate, see “Leading Edge” section.
5. If there is damage that extends onto the baseplate, side skis, longitudinal skis, or center ski, go to those specific sections below.
6. Remove and assess damage to components: HV cables, baseplate, fasteners, etc.

**NOTE:** The bolt that threads into the doubler is circled in Figure 11 and Figure 12. There is another bolt symmetrically on the other side of the vehicle. These bolts are prone to shearing in the event of front skid plate damage (Figure 12).



Figure 11 – Skid plate to doubler fastener



Figure 12 – Skid plate to doubler fastener sheared/bent

**Suggest repair to customer:**

- Recommend replacement of the fastener if a fastener attaching the front skid plate to the doubler is damaged or stripped.
- Re-tap the fastener hole if a fastener hole is damaged and the fastener cannot withstand full torque.
- Recommend the replacement of the front skid plate if the front skid plate, or part of the skid plate, is detached, or not covering the baseplate.
- Recommend the replacement of the HV cables if the HV cables are damaged above the front skid plate.
- Recommend HV battery replacement if:
  - A passthrough is damaged above the front skid plate.
  - The HV battery enclosure fails leak test due to impact.
  - The HV battery enclosure has low isolation due to impact.

**NOTE:** Do not drill new holes in any part of the HV battery, skid plates, rails, or baseplate.



# Side Skis

There are two side skis on each side of the HV battery (Figure 13). For each side ski, there is a “Side Ski Zone,” which extends 5 inches (127 mm) inward from the edge of the HV battery.

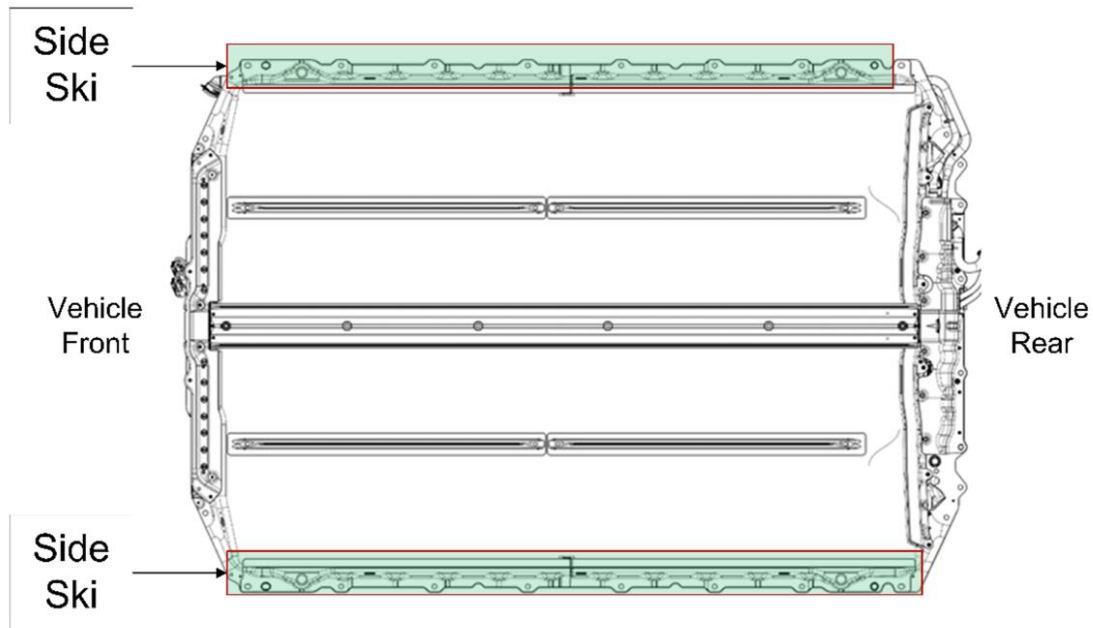

Figure 13 – Side Skis

## Suggest repair to customer:

- Recommend HV battery replacement if:
  - The ski, or part of the ski, is detached from the HV battery.
  - A jack point has extensive damage where it cannot be used to safely lift the vehicle.
  - The HV battery enclosure fails leak test due to impact.
  - The HV battery enclosure has low isolation due to impact.
- Recommend the replacement of the fastener if a fastener attaching the HV battery to the vehicle is damaged or stripped.
- Re-tap the fastener hole if a fastener hole is damaged and the fastener cannot withstand full torque.
- Deburr the area with a hand deburring tool to remove the sharp edges if sharp edges are found (Figure 14).

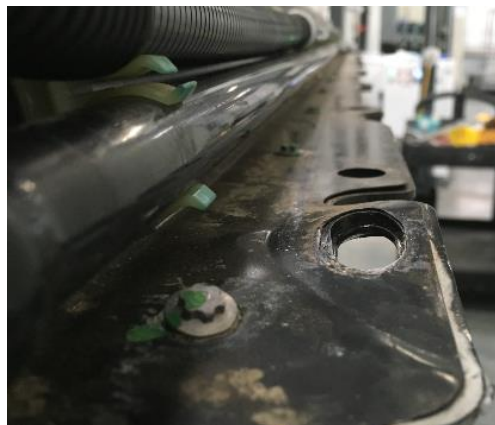
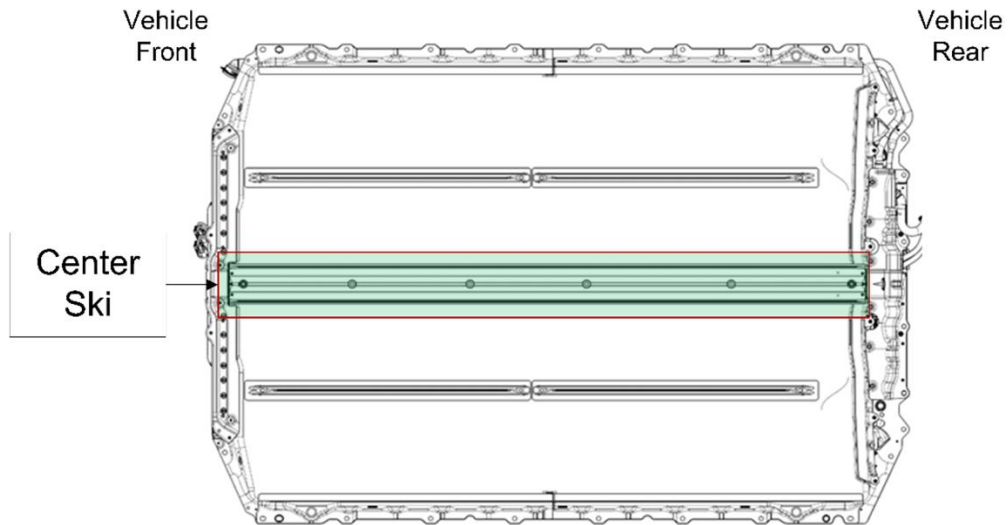

Figure 14 – Deburr the area to remove sharp edges

# Center Ski

The center ski is in the middle of the HV battery (Figure 15).



**Figure 15 – Center ski**

While the HV battery is still installed on the vehicle:

1. Visually inspect the center ski (Figure 16).
2. Remove the center ski and inspect the HV cables thoroughly (Figure 17).



**Figure 16 – Gouged center ski**



**Figure 17 – Damaged cable under center ski**

**NOTE:** Figure 16 shows an example of torn center ski that also damaged the HV cables (Figure 17). It is important to inspect for damage to the HV cables and baseplate underneath the ski.

3. Inspect the baseplate under the center ski (See “Baseplate” section below).

### Suggest repair to customer:

- Recommend the replacement of the center ski if the center ski, or part of the ski, is detached from the HV battery.
- Recommend the replacement of the HV cables if the HV cables are damaged.
- Recommend the replacement of the fastener if a fastener attaching the center ski to the HV battery enclosure is damaged or stripped.
- Re-tap the fastener hole if a fastener hole is damaged and the fastener cannot withstand full torque.
- Recommend HV battery replacement if:
  - The HV battery enclosure fails leak test due to impact.
  - The HV battery enclosure has low isolation due to impact.

## Longitudinal Skis

Longitudinal skis are located between the center ski and the side skis (Figures 18 and 19).

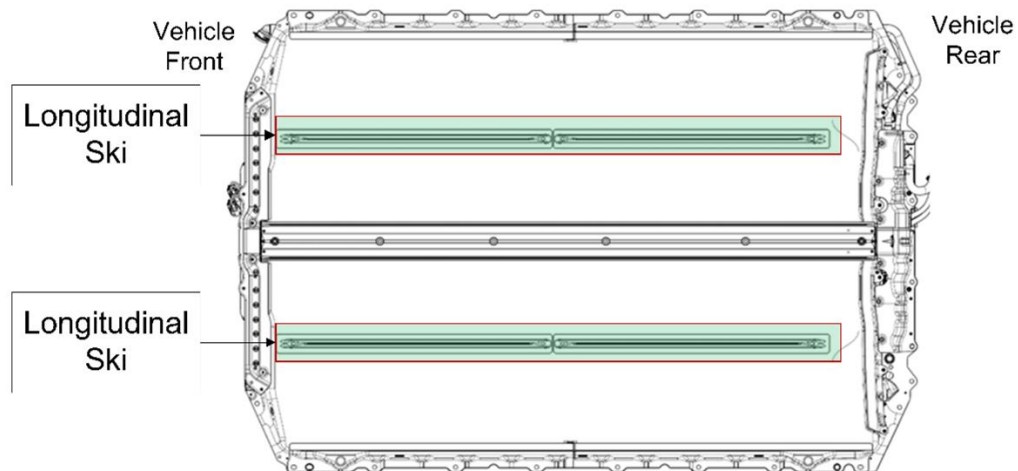

Figure 18 – Longitudinal skis



Figure 19 – Longitudinal ski

### Suggest repair to customer:

- Deburr the area with a hand deburring tool to remove the sharp edges if sharp edges are found.
- Recommend the replacement of the longitudinal ski if the longitudinal ski is detached.
- Recommend the replacement of the fastener if a fastener attaching the longitudinal ski to the HV battery enclosure is damaged or stripped.
- Re-tap the fastener hole if a fastener hole is damaged and the fastener cannot withstand full torque.
- Recommend HV battery replacement if:
  - The HV battery enclosure fails leak test due to impact.
  - The HV battery enclosure has low isolation due to impact.

## Baseplate

The baseplate, shown in Figure 20, covers the underside of the HV battery, and serves as a base for the center and longitudinal skis.

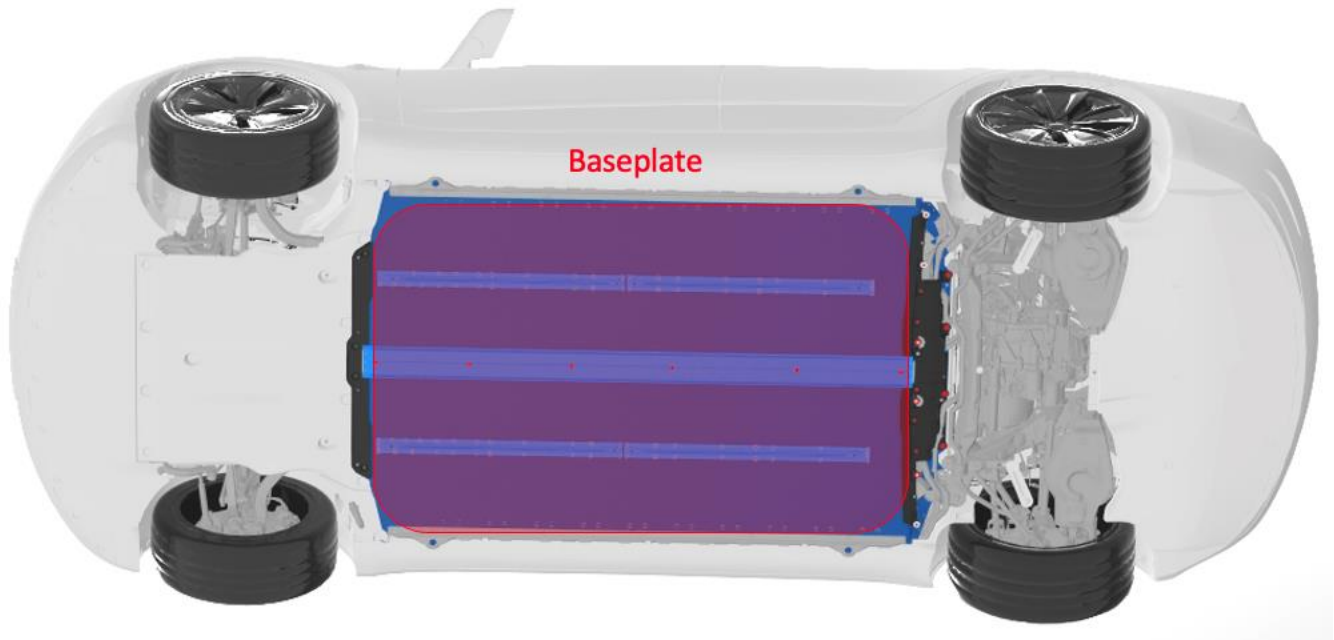

Figure 20 – Baseplate

The baseplate starts at the front edge of the HV battery, immediately to the rear of the front skid plate, and extends to the rear edge of the HV battery. When the baseplate is damaged, follow the steps below:

### Suggest repair to customer:

- Deburr the area with a hand deburring tool to remove the sharp edges if sharp edges are found.
- Recommend HV battery replacement if:
  - A dent is **8 mm** or more in depth (Figures 21 and 22).
  - If the HV battery enclosure fails leak down test due to impact.
  - If the HV battery enclosure has low isolation due to impact.

**NOTE:** The rear skid plate is not included in the baseplate area. See the “Rear Skid Plate” section if the rear skid plate is damaged.

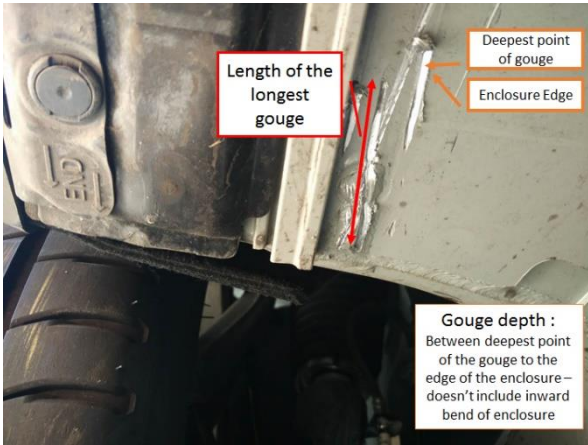

Figure 21 – Gouges in the baseplate

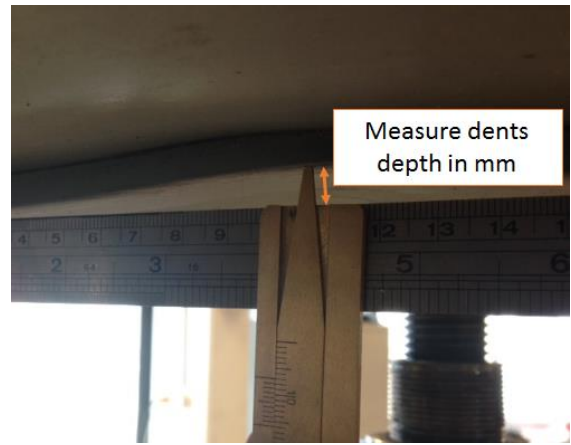

Figure 22 – Dents in the baseplate

## Leading Edge

The leading edge of the baseplate is forward of (or above) the dashed line (Figure 23). Anything behind or below the dotted line is in the Baseplate section.

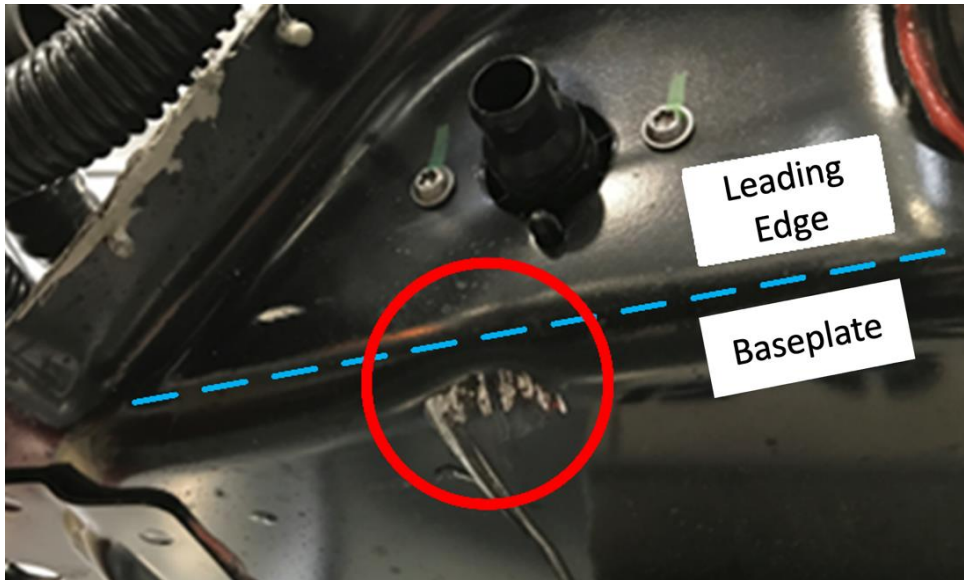

Figure 23 – Leading edge

**NOTE:** The dent inside the red circle within Figure 23 is not considered to be on the leading edge. The leading edge of the baseplate is forward of (or above) the dashed line. Anything behind or below the dotted line is in the Baseplate section.

### Suggest repair to customer:

- Deburr the area with a hand deburring tool to remove the sharp edges if sharp edges are found.
- Recommend the replacement of the HV cables if the HV cables are damaged.
- Recommend HV battery replacement if:
  - A passthrough is damaged.
  - The HV battery enclosure fails leak test due to impact.
  - The HV battery enclosure has low isolation due to impact.

## Rear Skid Plate

1. Visually inspect the rear skid plate for tears, dents, or breaches (Figure 24).

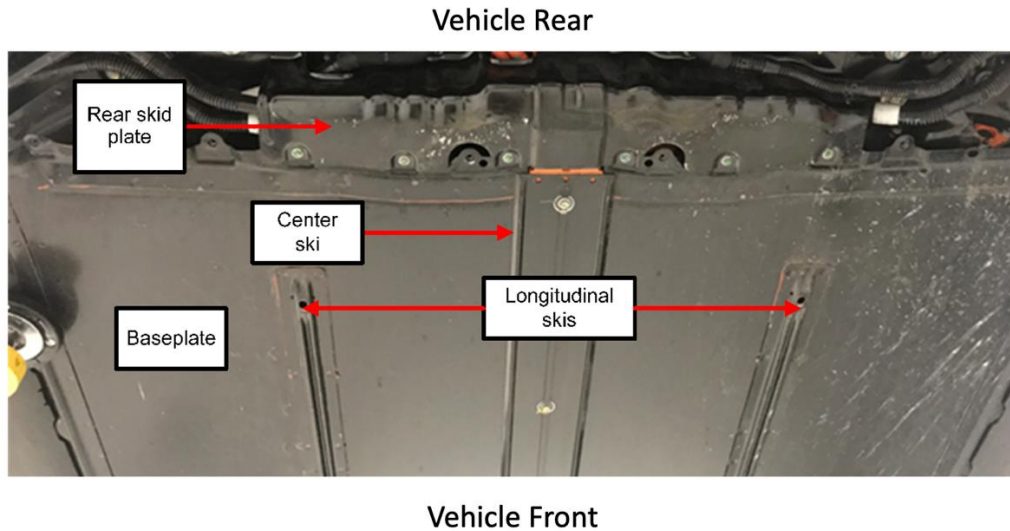

**Figure 24 – Skid plate location**

2. Remove the rear skid plate (Figure 25) (refer to Service Manual procedure 16102202).

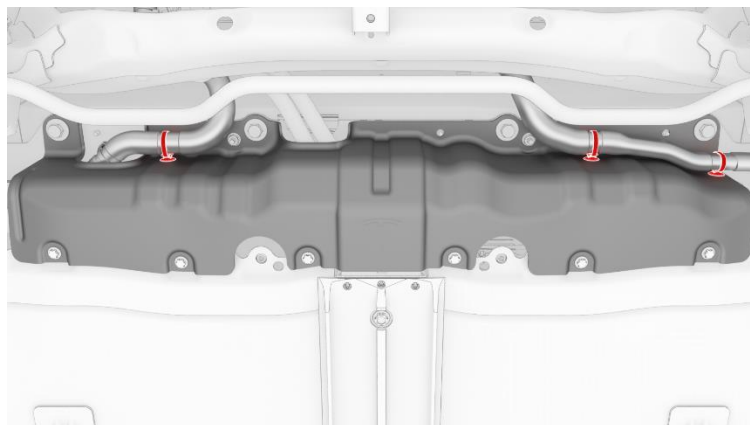

**Figure 25 –Skid plate**

3. Inspect the HV cables and passthroughs and replace any compromised components.
4. Remove and assess damage to components such as HV cables, baseplate, fasteners, etc.

**Suggest repair to customer:**

- Recommend the replacement of the rear skid plate if the rear skid plate is detached or does not cover the rear baseplate when secured and torqued correctly.
- Recommend the replacement of the HV cables if the HV cables are damaged.
- Recommend the replacement of the fastener if a fastener attaching the longitudinal ski to the HV battery enclosure is damaged or stripped.
- Re-tap the fastener hole if a fastener hole is damaged and the fastener cannot withstand full torque.
- Deburr the area with a hand deburring tool to remove the sharp edges if sharp edges are found.
- Recommend HV battery replacement if:
  - A passthrough is damaged.
  - The HV battery enclosure fails leak test due to impact.
  - The HV battery enclosure has low isolation due to impact.

For feedback on the accuracy of this document, email [ServiceBulletinFeedback@tesla.com](mailto:ServiceBulletinFeedback@tesla.com).