

TECHNICAL PARAMETERS Modal exciter S 50350-M

Rated peak force Sine _{pk} /Random _{RMS} ¹	2700/2000 N
Frequency range	1 - 3000 Hz
Main resonance frequency	> 3000 Hz
Max. displacement Peak-Peak	45 mm
Max. velocity	1.5 m/s
Suspension stiffness	electronically adjusted
Effective moving mass (±5%)	2.3 kg
Total mass	280 kg
Coupling thread	M8
Interlocks	Field coil temperature, displacement, cooling air, overcurrent

¹) Random force according to ISO 5344:2004

For long-term tests, the load must be reduced to 80 %. Continuous operation at maximum load can cause damage.

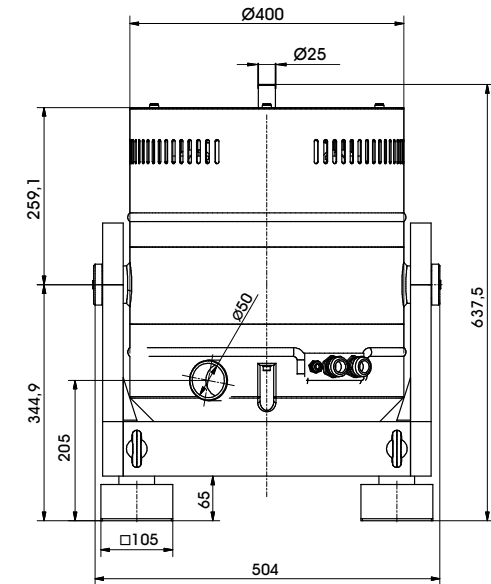

SCOPE OF DELIVERY, OPTIONS AND FEATURES OF THE SYSTEM

<p>Scope of delivery: Modal exciter 2.7 kN Trunnion mount Power amplifier 15 kVA Cooling blower Connection cable (5 m) Power cable (5 m) for amplifier (CEE 32 connector) Blower hose ø60 mm (5 m)</p>	<p>Options: Squeak&Rattle (Silent operation without blower) Remote control (Software) TIRA EMS Energy Management System Operation with temperature-controlled cooling blower (and optional with variable field strength) ASM-Mode (Auto Shutdown Manager) Silencer for cooling blower (Noise reduction up to 6 dB(A)) Acoustic enclosure for cooling blower (Noise reduction 15 - 23 dB(A)) Cable extension Factory acceptance test</p>	<p>Features: Vibration isolation < 6 Hz Coarse filter unit for cooling air Fully automatic electronic load compensation Electronic zero point regulation with adjustable stiffness Automatic centering of the armature Integrated mains switch and line filter Integrated field power supply 4 Sigma Peak current Made in Germany Servicehotline</p>
---	--	--

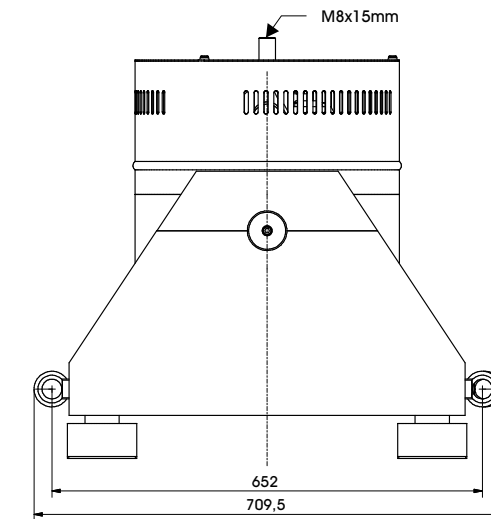

TECHNICAL PARAMETERS Amplifier A 1 02 11 021 T SV

Max. output power _{RMS} (factory-set)	15000 VA
Frequency range	DC - 5 kHz
Voltage _{RMS} , max.	±212 V
Current _{RMS} , max. (factory-set)	40-100 A
Signal input voltage _{RMS}	10 V
Total Harmonic Distortion (at 70A _{RMS} , 200 Hz)	< 0.2 %
Signal to noise ratio	> 80 dB
Field voltage (factory-set)	140-280 V
Field current (factory-set)	6-8 A
Total mass	330 kg
Dimensions (WxHxD)	600 x 1740 x 800 mm
Power supply (Standard)	3~ / N / PE 400 V±5% 50 Hz, CEE 32
Recommended fuse protection	32 A slow
Max. power consumption at 400 V (incl. blower)	17 kVA
Interlocks:	Overload, Temperature, Displacement, Cooling air, Phase monitoring, Emergency stop
Features:	
Field supply integrated	Mains switch and integrated line filter
Field voltage/Field current variable according to customer spec.	Color Touch Screen
4 Sigma peak current	
Electronic zero-point-regulation (TMC)	

TECHNICAL PARAMETERS Cooling blower TB 0310

Volume flow rate	max. 315 m³/h
Total pressure difference	max. 290 mbar
Power	4 kW
Frequency	50 Hz
Hose diameter	60 mm
Hose length (Std.)	5 m
Total mass	42 kg
Dimensions (WxHxD)	382 x 384 x 432 mm
Sound pressure level, max.	max. 69 dB(A)
Power supply (standard)	by amplifier rack
Max. current consumption at 400 V	7.2 A

Options:

Silencer TB 0310-SI (Noise reduction up to 6 dB(A))	
Dimensions (LxD): 308 x 82 mm	
Mass: 0.58 kg	
Acoustic enclosure TB 0310-AE (Noise reduction 15 - 23 dB(A))	
Dimensions (WxHxD): 860 x 760 x 650 mm	
Mass: 55 kg	
Hose length according to customers request (up to 10 m)	



Cooling blower TB 0310



Silencer TB 0310-SI (optional)



Acoustic enclosure TB 0310-AE (optional)