

TECHNICAL PARAMETERS Modal exciter S 57315-M/LSS

Rated peak force Sine _{pk} /Random _{RMS} ¹	15000/11000 N
Frequency range	1 - 2000 Hz
Main resonance frequency (free-swinging)	>2500 Hz
Max. displacement Peak-Peak ²	100 mm
Max. velocity	2.0 m/s
Suspension stiffness	electronically adjustable
Effective moving mass (±5%)	18.0 kg
Total mass	1200 kg
Coupling thread	M10
Interlocks	Field coil temperature, displacement, cooling air, overcurrent

1) Random force according to ISO 5344:2004
2) only with foundation mounting

For long-term tests, the load must be reduced to 80 %. Continuous operation at maximum load can cause damage.

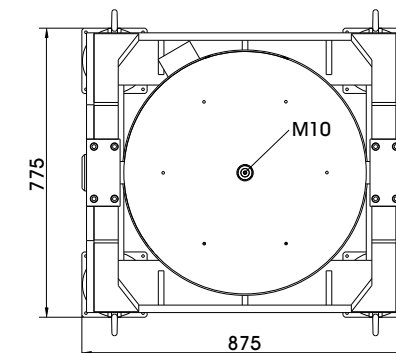
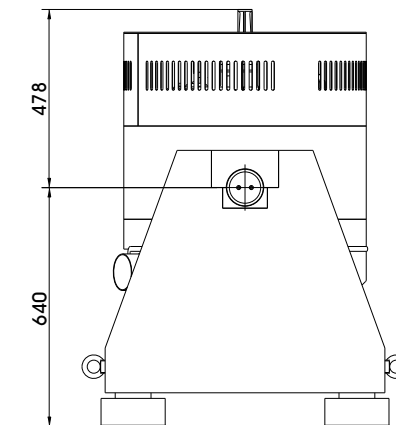
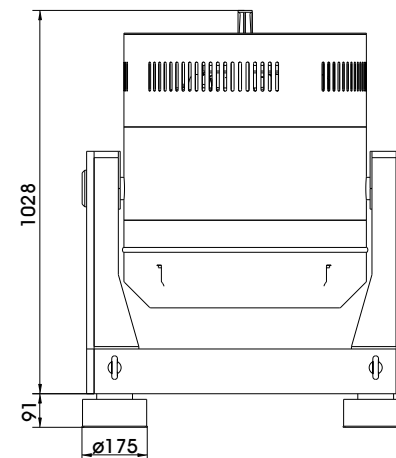

SCOPE OF DELIVERY, OPTIONS AND FEATURES OF THE SYSTEM

<p>Scope of delivery:</p> <ul style="list-style-type: none"> Modal exciter 15 kN Trunnion mount Power amplifier 37.5 kVA Cooling blower Connection cables (each 5 m) Power cables (5 m) for amplifier (CEE 63 connector) Blower hose ø140 mm (5 m) 	<p>Options:</p> <ul style="list-style-type: none"> Wheels&Rails (incl. 3m rails) Squeak&Rattle (Silent operation without blower) Remote control (Software) ASM-Mode (Auto Shutdown Manager) Silencer for cooling blower (Noise reduction 3 - 6 dB(A)) Acoustic enclosure for cooling blower (Noise reduction 5 - 23 dB(A)) Cable extension Factory acceptance test 	<p>Options:</p> <ul style="list-style-type: none"> TIRA EMS Energy Management System Operation with temperature-controlled cooling blower (and optional with variable field strength) <p>Features:</p> <ul style="list-style-type: none"> Vibration isolation < 6 Hz Coarse filter unit Fully automatic pneumatic load compensation Electronic zero point regulation with adjustable stiffness Automatic centering of the armature Made in Germany Servicehotline
--	---	--

TECHNICAL PARAMETERS Amplifier A 3 01 11 063 T

Output power _{RMS}	37500 VA
Frequency range	DC - 5 kHz
Voltage _{RMS} , max.	±212 V
Current _{RMS} , max.	300 A
Signal input voltage	10 V
Total Harmonic Distortion (at 70A _{RMS} , 200 Hz)	< 0.2 %
Signal to noise ratio	> 80 dB
Field voltage	140 V
Field current	8 A
Total mass	520 kg
Dimensions (WxHxD)	600 x 2200 x 800 mm
Power supply (Standard)	3~ / N / PE 400 V±5% 50 Hz, CEE 63
Recommended fuse protection (Standard)	63 A slow
Max. power consumption at 400 V (incl. blower)	29 kVA
Interlocks:	Overload, Temperature, Displacement, Cooling air, Phase monitoring, Emergency stop
Features:	
Field supply integrated	
Mains switch and integrated line filter	
Field voltage/Field current variable according to customer spec.	
4 Sigma peak current	
Electronic zero-point-regulation (TMC)	
Color Touch Screen	

TECHNICAL PARAMETERS Cooling blower TB 120 FUK

Max. volume flow rate	1500 m³/h
Total pressure difference	10.2 kPa
Motor output	5.5 kW
Max. frequency	100 Hz
Hose diameter	140 mm
Hose length (Std.)	5 m
Total mass	61 kg
Dimensions (WxHxD)	487 x 637 x 487 mm
Max. sound pressure level	102 dB(A)
Power supply (standard)	by amplifier rack
Max. current consumption at 400 V	13 A
Options:	
Silencer TB 120-SI (Noise reduction 3 - 6 dB(A))	
Dimensions (LxD): 1100 x 160 mm	
Mass: 1.2 kg	
Acoustic enclosure TB 120-AE (Noise reduction 5 - 23 dB(A))	
Dimensions (WxHxD): 1250 x 1393 x 1470 mm	
Mass: 103 kg	
Hose length according to customers request (up to 10 m)	

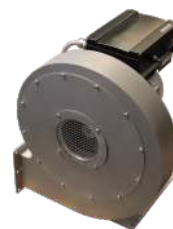

Cooling blower TB 120 FUK



Silencer TB 120-SI (optional)



Acoustic enclosure TB 120-AE (optional)