

## New Photovoltaic Devices Based on the Sensitization of p-type Semiconductors: Challenges and Opportunities

FABRICE ODOBEL,\* LOÏC LE PLEUX, YANN PELLEGRIN, AND ERROL BLART

Université de Nantes, CNRS, Chimie et Interdisciplinarité: Synthèse, Analyse, Modélisation (CEISAM), UMR CNRS n° 6230, 2 rue de la Houssinière – BP 92208 – 44322 Nantes cedex 3, France

RECEIVED ON NOVEMBER 12, 2009

### CON SPECTUS

**B**ecause solar energy is the most abundant renewable energy resource, the clear connection between human activity and global warming has strengthened the interest in photovoltaic science. Dye-sensitized solar cells (DSSCs) provide a promising low-cost technology for harnessing this energy source. Until recently, much of the research surrounding DSSCs had been focused on the sensitization of n-type semiconductors, such as titanium dioxide (Grätzel cells). In an n-type dye-sensitized solar cell (n-DSSC), an electron is injected into the conduction band of an n-type semiconductor (n-SC) from the excited state of the sensitizer. Comparatively few studies have examined the sensitization of wide bandgap p-type semiconductors. In a p-type DSSC (p-DSSC), the photoexcited sensitizer is reductively quenched by hole injection into the valence band of a p-type semiconductor (p-SC). The study of p-DSSCs is important both to understand the factors that control the rate of hole photoinjection and to aid the rational design of efficient p-DSSCs. In theory, p-DSSCs should be able to work as efficiently as n-DSSCs. In addition, this research provides a method for preparing tandem DSSCs consisting of a TiO<sub>2</sub>-photosensitized anode and a photosensitized p-type SC as a cathode. Tandem DSSCs are particularly important because they represent low-cost photovoltaic devices whose photoconversion efficiencies could exceed 15%.

This Account describes recent research results on p-DSSCs. Because these photoelectrochemical devices are the mirror images of conventional n-DSSCs, they share some structural similarities, but they use different materials and have different charge transfer kinetics. In this technology, nickel oxide is the predominant p-SC material used, but much higher photoconversion efficiencies could be achieved with new p-SCs materials with deeper valence band potential. Currently, iodide/triiodide is the main redox mediator of electron transport within these devices, but we expect that this material could be advantageously replaced with more efficient redox couples. We also discuss valuable information obtained by ultrafast transient absorption spectroscopy, which sheds some light on the factors that govern the efficiency of the cell. Notably, we demonstrate that ultrafast hole injection generally occurs between the sensitizer and the SC, but the resulting charge-separated state (e.g. electron on the sensitizer and hole in the VB) is short-lived and recombines quickly. So far, the only effective strategy for slowing the back recombination reaction relies on a bimolecular system consisting of the sensitizer linked to an electron acceptor, which increases the separation distance between the charges. A photoconversion efficiency of 0.41% under AM 1.5 was recently measured with a p-type DSSC using this strategy.

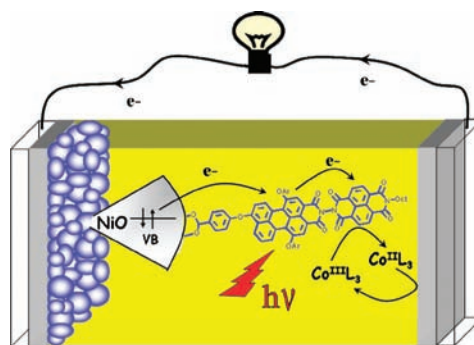

### Introduction

Since the seminal paper of Grätzel and co-workers in 1991,<sup>1</sup> intense research activity has been devoted to dye-sensitized solar cells (DSSCs).<sup>2–4</sup>

Today, DSSCs based on titanium dioxide are a well-established technology exceeding 11% photoconversion efficiency.<sup>5</sup> The indubitable advantage of DSSCs over conventional silicon solar cells

stems from their potential low cost due to cheap materials and cheap manufacturing technology. More recently, another type of DSSCs, based on the sensitization of a p-type semiconductor (p-SC), has emerged as a new generation of photoelectrochemical cells. The study of the sensitization of p-SC materials with dyes has been reported long ago, notably by German teams<sup>6–8</sup> and others,<sup>9–12</sup> who built a valuable knowledge in this area. However, all the photoelectrochemical devices described at that time were not true solar cells since photocurrent was delivered only when the photocathode was biased with an external potentiostat to collect the injected holes. To the best of our knowledge, it is only in 1999 that Lindquist and co-workers published the first true self-operating p-DSSC based on a porous nickel oxide electrode sensitized by a free-base porphyrin or by erythrosine B.<sup>13</sup> The overall photoconversion efficiency was very low (0.0076%) with a maximum incident-photon-to-current-conversion efficiency (IPCE) of 3.44% under AM 1.5.

After the presentation of the operation principle of p-DSSCs, this Account is divided in six sections. The three first sections precisely focus on the materials that compose the photoelectrochemical cell itself, starting with the sensitizers, the semiconductors, and finally the redox mediators. Then, we shall discuss the photophysical studies undertaken on these devices, the description of tandem DSSCs and we finish with some perspectives.

Upon light absorption, the sensitizer excited state ( $S^*$ ) injects a hole into the valence band (VB) of the semiconductor leading to the reduction of the sensitizer ( $S^-$ ) (eqs 1 and 2). If the charge recombination reaction between  $S^-$  and the hole in the valence band ( $h^+/\text{VB}_{\text{p-SC}}$ ) is slow enough (eq 3), the reduced sensitizer can be intercepted by the redox mediator (M) (eq 4). The injected holes diffuse to the back transparent conducting electrode (TCO) pass into the external circuit and reach the counter electrode where they oxidize the redox mediator back to its original state (eq 5). Summarily, the reactions involved in the operation principle are indicated below (Scheme 1).

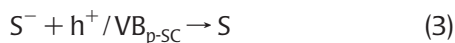

Based on the above operation principle, the free energies (in eV) of the hole injection ( $\Delta G_{\text{inj}}$ , eq 6) and regeneration reaction of the sensitizer ( $\Delta G_{\text{reg}}$ , eq 7) and of the charge recombination

( $\Delta G_{\text{CR}}$ , eq 8) can be determined according to the following equations:

$$\Delta G_{\text{inj}} = e[E_{\text{VB}}(\text{p-SC}) - (E_{00}(S^*) + E(S/S^-))] \quad (6)$$

$$\Delta G_{\text{reg}} = e[E(M/M^-) - E(S/S^-)] \quad (7)$$

$$\Delta G_{\text{CR}} = e[E(S/S^-) - E_{\text{VB}}(\text{p-SC})] \quad (8)$$

where  $E_{\text{VB}}$  is the valence band potential of the semiconductor,  $E_{00}(S^*)$  is the energy of the excited-state sensitizer,  $E(S/S^-)$  is the reduction potential of the sensitizer,  $E(M/M^-)$  is the reduction potential of the redox mediator, and  $e$  is the elementary charge. Accordingly, the maximum open-circuit voltage ( $V_{\text{OCmax}}$ ) that can be delivered by the cell is given by the difference of the Fermi levels ( $E_f$ ) of each electrode, which, in a first approximation, is given by eq 9:

$$V_{\text{OCmax}} = E(M/M^-) - E_{\text{VB}}(\text{p-SC}) \quad (9)$$

## The Sensitizers

Ideally, the sensitizers should absorb across a broad range of the solar spectrum (panchromatic dye) in order to harvest the greatest number of photons. High molar extension coefficients are particularly important in p-DSSCs, because it is difficult to prepare thick NiO films as compared with those of  $\text{TiO}_2$ . Naturally, the dye must be also photochemically and electrochemically stable to ensure the stability of the device over a long period of time. More particularly, the reduced form of the sensitizer ( $S^-$ ) must remain inert toward electrophilic substances. A further requirement for a viable dye is the need for a high hole injection quantum yield. This imposes that the reduction potential of the sensitizer excited state ( $E_{00}(S^*) + E(S/S^-)$

**SCHEME 1.** Schematic Representation of the Photoelectrochemical Device Based on p-SC

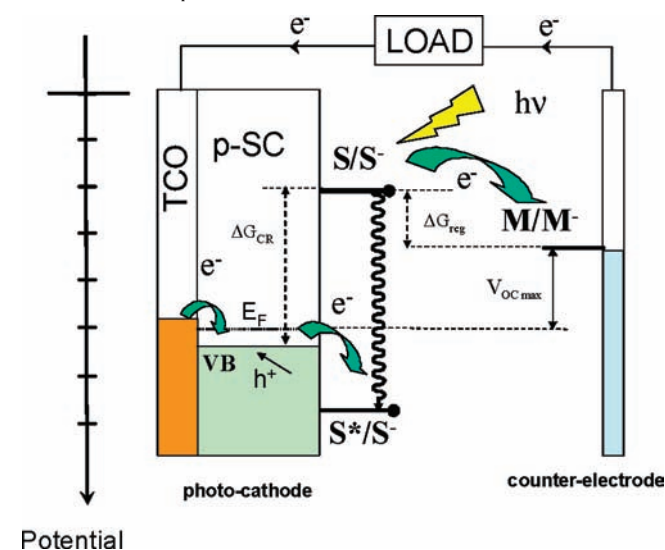

$S^-$ ) lies above the valence band edge of the semiconductor (eq 6,  $\Delta G_{inj} < 0$ ). Furthermore, the regeneration reaction of the sensitizer with the mediator must be thermodynamically allowed, imposing that the reduction potential of the sensitizer is more negative than that of the mediator (eq 7;  $\Delta G_{reg} < 0$ ). Finally, the sensitizers must be functionalized with anchoring groups, first to graft them on the semiconductor surface and second to provide a strong electronic coupling with the semiconductor. This latter criterion ensures a fast hole tunneling from the sensitizer excited state into the valence band of the semiconductor. This parameter is optimized when the HOMO of the dye significantly extends on the anchoring groups in order to overlap with the valence band orbital of the semiconductor.<sup>14</sup> Let us notice that the majority of dyes tested with p-type semiconductors were immobilized through carboxylic acid groups (Table 1), which is not necessarily optimal for hole injection, since it generally bears high spin densities of the LUMO rather than of the HOMO. Besides, with a view to performing charge photoinjection reactions, charge transfer excited-states are particularly well-suited, provided that the charge transfer in the excited-state is polarized in the appropriate direction. For efficient hole injection, a vectorial electron shift from the anchoring group toward the extremity of the dye is sought. Accordingly, electron-withdrawing anchoring groups do not fulfill this requirement and would lead to a situation where positive charge density is moved in the direction (far away from the surface of the p-SC) that will not facilitate the hole injection nor slow the charge recombination.

Lindquist and co-workers first demonstrated the generation of a cathodic photocurrent with a dye-sensitized, nanostructured NiO cathode coated with tetrakis(4-carboxyphenyl)porphyrin (TPPC), which gave a maximum IPCE of 0.24% on the Soret band and 3.44% IPCE with erythrosine on its most intense absorption band.<sup>13</sup> Odobel and co-workers prepared a phosphorus porphyrin featuring axial ligands bearing a carboxylic group, which was more suitable than free-base TPPC owing to its strong oxidizing power in the excited state. Indeed the maximum IPCE reached 2.5% on the Soret absorption band.<sup>23</sup> Coumarin C343, a commercially available laser dye, is commonly used as sensitizer in p-DSSCs and has become a benchmark reference. It gave  $J_{SC}$  values between 0.5 and 0.9 mA · cm<sup>-2</sup>,  $V_{OC}$  values around 100 mV, and photoconversion efficiencies in the range of 0.02–0.06% depending on the preparation method of the NiO film (Table 1).<sup>15–19</sup> Another coumarin dye, NKX-2311, whose absorption spectrum is red-shifted compared with the yellow C343, was also used by Mori and co-workers, but the short-circuit photocur-

rent was lower than that of C343.<sup>18</sup> The same group studied a series of different cyanine dyes such as NK-2684, NK-3628, or NK-2612, which gave particularly high photocurrent densities, most certainly thanks to the very high absorption coefficients of this class of dyes (Table 1).<sup>18</sup>

Sun and co-workers recently broke records in terms of maximum IPCE with particularly efficient “push–pull” dyes consisting of a triphenylamine donor group and a dicyanovinylene acceptor unit connected by a thiophene (P1)<sup>16</sup> or a phenyl (P4)<sup>16</sup> linker. An IPCE of 18% was initially reported with P1 using a mesoporous NiO film of only 0.6  $\mu\text{m}$  thickness,<sup>21</sup> while with thicker film, the APCE value reached 69% with dye P4.<sup>24</sup> This underscores the importance of a rightly polarized charge transfer excited state with high molar extension coefficients to achieve high performances. Perylene imide derivatives are particularly appealing sensitizers for p-DSSCs, because they exhibit strong absorbance in the visible and high photostability and they are particularly good electron acceptors.<sup>25</sup> Perylene monoimide (PMI, Figure 2) is representative of this family whose maximum IPCE was only about 4%, but it was recorded on very thin and unoptimized cells.<sup>26</sup> The most efficient sensitizers of NiO consist of  $\pi$ -conjugated thienyl unit linked to a PMI electron acceptor (Table 1). These dyads exhibit long-lived charge-separated states (see below), which is most certainly an important characteristic for NiO p-DSSCs.<sup>22</sup>

## The p-type Semiconductors

The candidates for the fabrication of the photocathodes are the p-type semiconductors that are primarily resistant to photocorrosion, which is why wide bandgap SCs are particularly suitable for this application. Second, the SC must be easily synthesized as nanoparticles, in order to be transformed into mesoporous films that exhibit large surface area. Third, the surface of the p-SC must exhibit high chemical affinity to an organic functional group in order to promote the chemisorption of the sensitizers on its surface by a simple self-assembling reaction. Finally, the position of the valence band potential is another fundamental parameter of the p-SC because it governs the maximum  $V_{OC}$  that the cell can deliver (eq 9). Unlike n-DSSCs, for which several semiconductors have been used to prepare photoanodes<sup>27</sup> such as TiO<sub>2</sub>, ZnO, Nb<sub>2</sub>O<sub>5</sub>, and ZnO, there are fewer metal oxides that exhibit p-type semiconductivity. Nickel oxide has been widely used as p-type SC for the fabrication of p-DSSCs, most certainly because there have been long ago several reports for the preparation of porous NiO films on conducting glass for the development of electrochromic devices. NiO has also drawn much attention due to its utilization for other applications,

TABLE 1. Sensitizers Used in NiO p-DSSCs with Their Photovoltaic Characteristics<sup>a</sup>

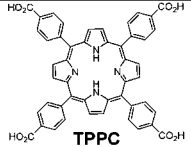
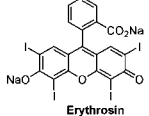
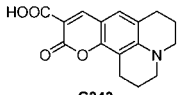
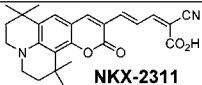
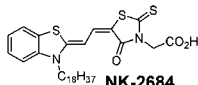
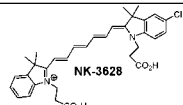
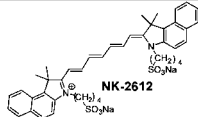
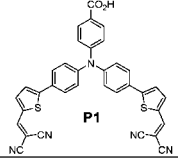
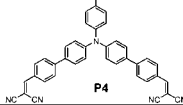
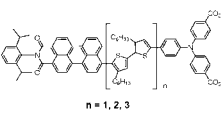
Sensitizer	J <sub>sc</sub> (mA/ cm <sup>2</sup> )	V <sub>oc</sub> (mV)	ff	η (%)	E <sub>00</sub> (S*) (eV)	E(S/S*) (V)	E(S*/S*) (V)	Ref.
 <b>TPPC</b>	0.079	98.5	0.285	0.0033	1.9	-0.90	1.00	13
 <b>Erythrosin</b>	0.36	122	0.26	0.011	2.3	-1.11	1.19	15
	0.232	82.8	0.27	0.008				13
 <b>C343</b>	0.78	70	0.32	0.052				16
	1.61	113	0.31	0.057				17
	0.55	98	0.29	0.016	2.6	-1.2	1.4	15
	0.86	101	0.362	0.031				18
0.88	117	0.35	0.036				19	
 <b>NKX-2311</b>	0.66	100	0.335	0.022	1.99	n. r.	n. r.	18
 <b>NK-2684</b>	1.00	93	0.30	0.027	2.41	n. r.	n. r.	20
	1.30	123	0.344	0.055				18
 <b>NK-3628</b>	0.43	77	0.343	0.011	1.65	n. r.	n. r.	18
 <b>NK-2612</b>	0.45	73	0.40	0.013	1.48	n. r.	n. r.	18
 <b>P1</b>	1.52	110	0.31	0.05	2.25	-0.83	1.42	16
	2.51	110	0.29	0.08				21
 <b>P4</b>	2.48	100	0.36	0.09	2.38	-0.74	1.64	21
 <b>n = 1, 2, 3</b>	2.06 (n=1)	153 (n=1)	29 (n=1)	0.09 (n=1)	2.11 (n=1)	-1.21 (n=1)	0.90 (n=1)	22
	3.4 (n=2)	176 (n=2)	32 (n=2)	0.19 (n=2)	2.16 (n=2)	-1.23 (n=2)	0.93 (n=2)	
	5.35 (n=3)	218 (n=3)	35 (n=3)	0.41 (n=3)	2.11 (n=3)	-1.22 (n=3)	0.89 (n=3)	

<sup>a</sup> All potentials are referenced versus NHE.  $E(S^*/S^-) = E_{00}(S^*) + E(S/S^-)$ ; n. r. indicates not reported.

such as gas sensors, catalysts, magnetic materials, electrochromic devices, and fuel cells. Therefore, NiO-based materials are well-known, and a great deal of information is available about them.<sup>28,29</sup> Nickel oxide is an intrinsic nonstoichiometric p-type

semiconductor with wide bandgap ( $E_g = 3.6-4$  eV), exhibiting good thermal and chemical stability. The valence band potential is positioned at 0.54 V vs NHE at pH = 7,<sup>30</sup> which makes it a particularly good electron donor for many photo-

sensitizers. As a result, the reductive quenching of many sensitizers is a strongly allowed process, but the low-lying valence band potential makes it difficult to obtain a large  $V_{OC}$  with such material. Furthermore, p-type metal oxides are known to be much poorer electronic conductors than n-type metal oxides, which is why transparent conducting oxides (TCOs) are mostly n-type (such as  $\text{SnO}_2/\text{F}$ ,  $\text{In}_2\text{O}_3/\text{Sn}$  or  $\text{ZnO}/\text{Al}$ , etc.). Photoinduced absorption spectroscopy measurements indicate that the hole diffusion coefficient in NiO films is in the range of  $10^{-8}$  to  $10^{-7} \text{ cm}^2 \cdot \text{s}^{-1}$ , which is more than 2 orders of magnitude lower than electron diffusion coefficient in  $\text{TiO}_2$ .<sup>18,24</sup> The slow diffusion of holes into NiO gives rise to a long time delay between injection of holes and their collection, increasing their potential scavenging by the redox mediator. Therefore, new p-SCs exhibiting higher conductivities than NiO could be certainly beneficial to build efficient p-DSSCs. Usually, the preparation of nanoporous NiO electrodes for DSSCs required the synthesis of nickel dihydroxide, which is subsequently dehydrated at high temperature.<sup>31</sup> However, other alternative routes were reported, such as chemical vapor deposition,<sup>32</sup> electrodeposition,<sup>33</sup> hydrothermal synthesis,<sup>17,19,34,35</sup> sputtering,<sup>36</sup> and sol–gel.<sup>37</sup> Suzuki and co-workers showed that the use of poly(ethylene oxide)–poly(propylene oxide)–poly(ethylene oxide) triblock copolymers as template leads to particularly good quality NiO electrodes for p-DSSCs.<sup>38</sup> Bach and co-workers reported that NiO films can be prepared from commercial NiO nanopowders.<sup>15</sup> Le Pleux and co-workers reported a simple hydrothermal preparation of NiO films on FTO electrodes, which is particularly suitable to fabricate reproducible and efficient p-DSSCs.<sup>19</sup> Very recently, an improvement of the Suzuki method enables devices to reach higher IPCE.<sup>24</sup>

## The Electron Shuttle

The role of the electron shuttle is to regenerate the reduced sensitizers after the hole injections in the p-SC valence band and to transport the electrons to the counter electrode (Scheme 1). To fulfill this function, the redox mediator should display several key properties. First of all, it must not absorb significantly in the visible region (400–800 nm) to avoid light screening of the sensitizer. This characteristic is particularly crucial for the oxidized form, the concentration of which is higher than that of the reduced form in this type of solar cell.<sup>15,39</sup> Second, the redox couple should display a fast electron self-exchange rate and a high diffusion coefficient to ensure a quick transport of the charges to the counter electrode, since the distance between the two electrodes is in general on a 10  $\mu\text{m}$  scale. The reduction potential of the redox

mediator ( $E(\text{M}/\text{M}^-)$ ;  $E(\text{I}_3^-/\text{I}_2^-) = -0.35 \text{ V}$  vs NHE) must be more positive than that of the sensitizer ( $E(\text{S}/\text{S}^-)$ ) to afford a significant driving force for the regeneration reaction (eq 7).  $E(\text{M}/\text{M}^-)$  must be also more negative than the valence band potential of the p-SC (0.54 V vs NHE for NiO) to ensure a decent  $V_{OC}$  (eq 9). Therefore,  $E(\text{M}/\text{M}^-)$  is restricted between  $E(\text{S}/\text{S}^-)$  and  $E_{VB}(\text{p-SC})$ ; that is,

$$E(\text{S}/\text{S}^-) < E(\text{M}/\text{M}^-) < E_{VB}(\text{p-SC})$$

But probably, the most difficult criterion to meet is to find a redox couple for which the reduction is a fast process with a low overpotential ( $\text{M} \rightarrow \text{M}^-$ , fast) while the oxidation of  $\text{M}^-$  is kinetically slow with a large overpotential ( $\text{M}^- \rightarrow \text{M}$ , slow). These conditions are crucial to regenerate quickly the reduced sensitizer and to limit the energy wasting reactions between the holes in the p-SC or in the TCO with the reduced mediator species (eq 10).

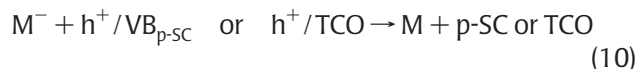

Until now, the iodide/triiodide electrolyte has almost exclusively been used as redox mediator in p-type DSSCs, but it is far from ideal for this type of solar cells. Its first drawback comes from the close proximity of its redox potential (0.4 V vs NHE) with that of the valence band of NiO (0.54 V vs NHE at pH = 7), which prevents it from reaching large photopotential (eq 9). Second, it is known that the reduction of triiodide into iodide is a slow process without catalyst,<sup>40</sup> while the oxidation of iodide into triiodide is relatively fast, thus making this redox couple well-suited to transport holes in classical DSSCs made with n-SC but particularly unsuitable to transport electrons in p-DSSCs. Indeed, the regeneration reaction (eq 4) may not compete with the recombination reactions (eq 5) and limits the photocurrent as already observed in n-DSSCs when the iodide/triiodide electrolyte is replaced by other redox couples.<sup>41</sup> Apart from the corrosive aspect of triiodide, another drawback comes from its strong absorbance, which becomes significant in p-DSSCs because it is more concentrated than in n-DSSCs ( $[\text{I}_3^-] > 0.1 \text{ M}$ ).<sup>15,39</sup>

Recently, a complex of tris(4,4'-bis-*tert*-butyl-2,2'-bipyridine)cobalt has been proposed as a new redox mediator in a NiO-based p-DSSC and proved to be particularly efficient, because the  $V_{OC}$  of the cell has been increased by more than a factor of 3 compared with the classical iodide/triiodide electrolyte (from 100 to 350 mV), while the photocurrent density was kept to an acceptable value (Figure 1).<sup>47</sup> It is however important to note that this new cobalt mediator works only when the charge-separated lifetime of the sensitizer (eq 5) is

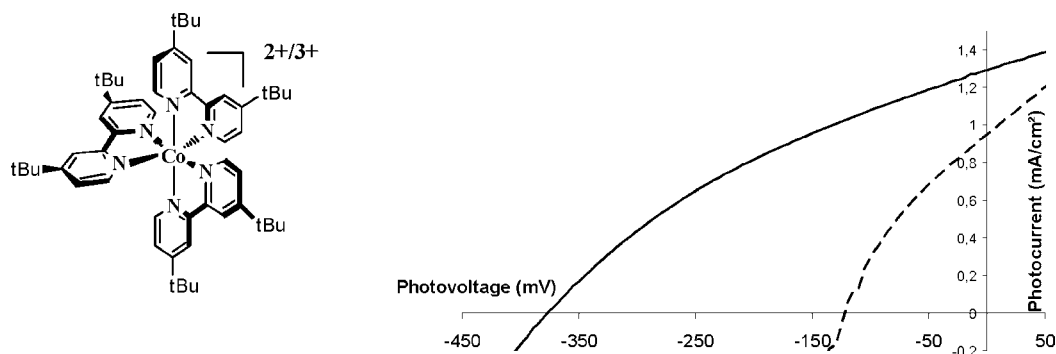

**FIGURE 1.** Structure of the cobalt redox mediator (left) and overlay of the photocurrent/photovoltage characteristics (right) of the dyad PMI–NDI on NiO photocathode using the iodide/triiodide electrolyte (dashed line) or the cobalt electrolyte (solid line).

particularly long, such as that obtained by the dyad PMI–NDI (see below). Unfortunately, the cobalt electrolyte gave low photocurrent and low photovoltage with all the monomolecular sensitizers tested so far in our laboratory.

## Photophysical Studies of Chemisorbed Dyes on NiO

In their first report of p-DSSC and in absence of photophysical study, Lindquist and co-workers postulated two operation mechanisms to account for the electricity production.<sup>13</sup> One mechanism was the direct hole injection from the sensitizer excited-state into the valence band as depicted in Scheme 1. The alternative mechanism consisted of a first electron transfer occurring from the excited state of the dye to the triiodide redox mediator eventually followed by electron transfer from the valence band of NiO to  $S^+$ . This so-called photogalvanic process was also proposed to rationalize the cathodic photocurrent observed sometimes in TiO<sub>2</sub> solar cells.<sup>42</sup> However, the first photophysical study devoted to p-DSSC appeared in 2005 and was made by the Swedish team of Hammarström who investigated the deactivation pathway of coumarin C343 attached to NiO nanoparticles.<sup>43</sup> While the hole injection into the valence is very fast (210 fs as major component), the charge recombination reaction is much faster than what is generally observed in TiO<sub>2</sub>-based DSSCs,<sup>2</sup> since the reduced coumarin C343 recombines with the injected hole within 1 ns, which is about 3 orders of magnitude faster than in n-DSSCs.<sup>43,44</sup> The very fast charge recombination reaction, which seems to be general with NiO, is certainly one of the main factors at the origin of the low photoconversion efficiency of the reduced sensitizer. Indeed, the rapid recombination reaction prevents the interception of the reduced sensitizer by the redox mediator. The full mechanism of photocurrent generation of p-DSSC with coumarin C343 in presence of the iodide/triiodide electrolyte was elucidated very recently and provided three important insights.<sup>44</sup> First, the

intersystem crossing quantum yield of the coumarin to generate the triplet excited state was increased owing to the presence of the large concentration of iodide (heavy atom effect). Second, the reaction of C343<sup>-</sup> with triiodide generates I<sub>2</sub><sup>-</sup> in a few picoseconds, but contrary to expectation, the latter species has a strikingly long lifetime, since it recombines with the injected holes in NiO in a few seconds. Therefore, the back reaction with the reduced mediator is, a priori, not the major pathway of losses. The two first observations plead in favor of a preassociation of triiodide with the coumarin to enable such fast quenching of the excited state. However, it is important to note that the sensitizers studied<sup>23,43</sup> unfortunately display very similar absorption spectra for both the reduced sensitizer ( $S^-$ ) and the triplet excited state ( $^3S^*$ ) preventing thus the unambiguous characterization of the hole photoinjection into the valence band of NiO.

The first strong support for the sensitizing mechanism of NiO came with the study of the perylene imide derivative PMI (Figure 1) published in 2008,<sup>26</sup> and it is corroborated by more recent results with other dyes.<sup>22,45</sup> The perylene imide derivatives feature well-defined spectroscopic signatures for the reduced anions, which are distinct from the excited-state spectral features, making these species reliably detectable by pump–probe experiments. PMI injects a hole into the valence band of NiO (within 0.5 ps) with almost 100% quantum yield, and the recombination is very rapidly (90% within 500 ps). A breakthrough came with the dyad PMI–NDI, which performs an electron transfer cascade yielding for the first time a very long-lived charge-separated state (Figure 2).<sup>47</sup> The latter state recombines with time constants of  $\tau_1 \approx 5 \mu\text{s}$  (60%) and  $\tau_2 \approx 50 \mu\text{s}$  (40%), which corresponds to an extension of the lifetime by a factor of 10<sup>5</sup> compared with the parent PMI sensitizer.<sup>47</sup> With a similar strategy, Bäuerle and co-workers, very recently, prepared other dyads consisting of an oligothiophene linked to a PMI (Table 1) exhibiting an even longer lived charge-separated state ( $\tau_1 \approx 13 \mu\text{s}$  for  $n = 3$ ).

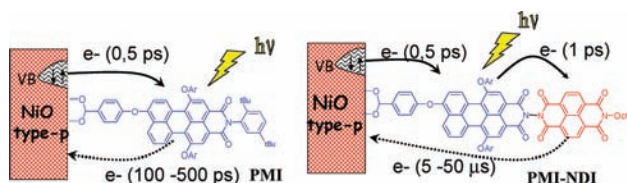

**FIGURE 2.** Representation of the deactivation mechanism of PMI (left) and PMI-NDI (right) on a NiO surface. Solid arrow = forward charge separation. Dotted arrow = charge recombination reaction.

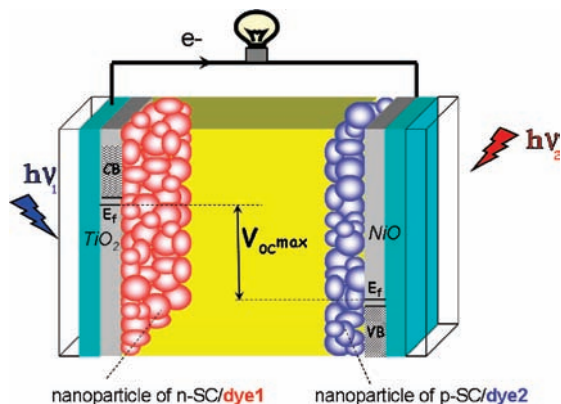

**FIGURE 3.** Schematic representation of a tandem DSSC.

## Tandem DSSCs

Implementation of a photocathode (sensitized p-SC) with a photoanode (sensitized TiO<sub>2</sub> photoanode) opens the possibility to fabricate tandem DSSCs (Figure 3). The overall photoconversion efficiencies of such devices could surpass those of conventional n-DSSCs. First of all, from a theoretical point of view, it is accepted that the maximum photoconversion efficiency of the photovoltaic device depends on the number of SCs that compose the cell.<sup>46</sup> It goes from 31% in a single semiconductor photovoltaic cell to 42% in a tandem cell including two different semiconductors. Second, in a tandem DSSC, the photovoltage is independent of the redox potential of the mediator and depends only on the difference between the potentials of the valence band of the p-SC and the conduction band of the n-SC (eq 11). Let us bear in mind that in the case of TiO<sub>2</sub> DSSCs using iodide-based electrolyte, the maximum  $V_{OC}$  is definitely limited to about 1 V. However, a larger  $V_{OC}$  could be achieved in tandem cells. Knowing that the photoconversion efficiency ( $\eta$ ) is directly proportional to the  $V_{OC}$ , a substantial increase of the latter has a strong impact on  $\eta$  (eq 12). Consequently, making a tandem cell is certainly a pertinent strategy to enhance  $\eta$  of dye-sensitized solar cells.

$$V_{OC} = E_{VB}(p\text{-SC}) - E_{CB}(n\text{-SC}) \quad (11)$$

$$\eta = J_{SC} V_{OC} (ff / I_c) \quad (12)$$

In eq 12,  $J_{SC}$  is the short-circuit current density,  $ff$  is the fill factor, and  $I_c$  is the intensity of the incident light.

Finally, a tandem cell contains two different sensitizers (one on each photoelectrode); therefore a larger portion of the solar spectrum could be harvested, since it is easier to cover a broad absorption window with two different dyes having complementary absorption spectra than with a single one.

In 2000, shortly after the first preparation of the p-DSSC, Lindquist and co-workers reported the first tandem DSSC composed of a TiO<sub>2</sub> photoanode sensitized with *cis*-di(thiocyanato)-*N,N*-bis(2,2'-bipyridyl-4,4'-dicarboxylic acid)-ruthenium(II) (N719) and a NiO photocathode sensitized with erythrosine B.<sup>30</sup> The photoconversion efficiency was low ( $\eta = 0.39\%$  under AM 1.5) because the  $J_{SC}$  was limited by the intrinsic performances of the NiO photocathode. However, the  $V_{OC}$  of the tandem cell reached 732 mV, which was 82 mV higher than that of the n-DSSC with TiO<sub>2</sub> ( $V_{OC} = 650$  mV) and than that of the p-DSSC with NiO ( $V_{OC} = 83$  mV), proving thus that tandem DSSCs could deliver a larger photopotential than single semiconductor DSSCs. In 2005, Suzuki and co-workers prepared a DSSC tandem cell with better performance, since they achieved a 0.918 V open circuit voltage with a 3.62 mA/cm<sup>2</sup> short current density, which gave a 0.66% overall photoconversion efficiency.<sup>20</sup> The improved solar energy conversion stemmed from the higher quality of the mesoporous NiO film prepared by the triblock polymer mentioned above and most certainly by the utilization of a more efficient dye (merocyanine NK-2684) on the NiO electrode.

Using the cobalt complex as redox mediator and the PMI-NDI dyad as dye on the NiO photoanode and the N719 ruthenium complex on the TiO<sub>2</sub> photoanode, a tandem cell was built the performance of which was  $J_{SC} = 0.97$  mA/cm<sup>2</sup>,  $V_{OC} = 910$  mV, and  $\eta = 0.55\%$ .<sup>47</sup> Interestingly, the  $V_{OC}$  of this new tandem cell (0.91 V) matches relatively well the sum of the voltages delivered by each photoelectrode (0.35 + 0.66 = 1.01 V), thus underscoring the possibility to reach, in the future, higher voltages when new p-SC photocathodes or new electrolytes will be used. However, the best photoconversion efficiency in tandem DSSC cells was recently obtained with the oligothiophene-PMI dyad (Table 1,  $n = 3$ ) and iodide/triiodide electrolyte ( $J_{SC} = 4.07$  mA/cm<sup>2</sup>;  $V_{OC} = 958$  mV;  $\eta = 2.42\%$ ).<sup>22</sup>

## Conclusions and Future Outlooks

The first report on a p-DSSC appeared in 1999, but this field is rapidly expanding, since among the about 20 relevant papers now available, the last 12 were published in 2008–2009. In addition, within the past 10 years, significant progress was made, since the maximum IPCE passed from 3.44%<sup>13</sup> to 44%<sup>21</sup> and the overall photoconversion effi-

ciency has been multiplied by more than a factor of forty to reach the value of 0.41%.<sup>22</sup> It is also clear that the iodide/triiodide system, which is well-suited in n-type photoelectrochemical devices, is far from being suitable for p-DSSCs. The discovery of the new cobalt mediator is certainly a significant step toward this direction, but it can be anticipated that other redox mediators are likely to give even higher performances. As far as the materials are concerned, the replacement of nickel oxide by another "p-type" SC is certainly another major source of improvement. Indeed, despite the recently achieved progresses, the preparation of high-quality and thick mesoporous NiO films remains a difficult task. Besides and probably more important, the use of new p-SCs with deeper valence band potentials than NiO would be most certainly beneficial to reach higher photoconversion efficiencies. A limited number of sensitizers have been tested so far in p-DSSCs, therefore it is very likely that in the near future new molecules will appear in the literature yielding higher photocurrent. To achieve cost-effective but efficient sensitizers, it would be particularly important to develop simpler dyes to synthesize than sensitizer-acceptor dyads (such as PMI-NDI or oligothiophene-PMI) that would, however, achieve a long-lived charge-separated state. Replacing NiO with a new p-SC could be an effective strategy to overcome this problem. Finally, the development of tandem cells is certainly a promising solution to reach photoconversion efficiency over 15% with DSSCs, but breakthroughs in this area will be intimately connected with the progress made on single semiconductor p-DSSCs; that is why basic research in sensitization of p-SCs will play a major role toward this goal. Taking into account that we have barely started to explore this new research field and the number of adjustable parameters, there are certainly plenty of exciting discoveries to be made, and we can anticipate that important progress will be achieved in the near future.

*The authors thank the "Région Pays de la Loire" for financial support with the "PERLE" program and the ANR with the "PhotoCumElec" program.*

**Note Added after ASAP.** This paper was published on the Web on May 10, 2010, with several citations of ref 47 omitted. The corrected version was reposted on June 8, 2010.

#### BIOGRAPHICAL INFORMATION

**Fabrice Odobel** (1966) received his Ph.D. in 1994 at Strasbourg University under the supervision of Prof. Jean-Pierre Sauvage. After postdoctoral research with Prof. Ronald Breslow, Columbia University (New York), he joined CNRS as a full time researcher in 1995. He currently leads the group of the Photonic and Molecular Engi-

neering in CEISAM laboratory at Nantes University. His research interests include the development of new materials for photovoltaic devices, artificial photosynthesis, and nonlinear optics.

**Loïc Le Pleux** was born in 1983. In 2007, he received a chemical engineering master degree (M.Sc. + 1) specialized in *Fine Organic Chemistry* from the University Nantes. He is currently a Ph.D. student working in the Odobel group.

**Yann Pellegrin** was born in 1976 and received his Ph.D. in 2004 at Orsay University. He has been recruited as a CNRS research fellow in 2007, after a postdoctorate in Prof. R. Forster's group (Dublin University).

**Errol Blart** was born in 1965 and received his Ph.D. in organic chemistry in 1993. After a short postdoctoral stay with Prof. A. Ricci (Bologna University), he became a lecturer in Nantes in 1996.

#### FOOTNOTES

\*To whom correspondence should be addressed. E-mail: Fabrice.Odobel@univ-nantes.fr. Fax: +33 251125402. Tel: +33 251125429.

#### REFERENCES

- O'Regan, B.; Grätzel, M. A low-cost, high-efficiency solar cell based on dye-sensitized colloidal titanium dioxide films. *Nature* **1991**, *353*, 737–740.
- Kalyanasundaram, K.; Grätzel, M. Applications of functionalized transition metal complexes in photonic and optoelectronic devices. *Coord. Chem. Rev.* **1998**, *177*, 347–414.
- Polo, A. S.; Itokazu, M. K.; Murakami Iha, N. Y. Metal complex sensitizers in dye-sensitized solar cells. *Coord. Chem. Rev.* **2004**, *248*, 1343–1361.
- Gonçalves, L. M.; Bermudez, V. d. Z.; Ribeiro, H. A.; Mendes, A. M. Dye-sensitized solar cells: A safe bet for the future. *Energy Environ. Sci.* **2008**, *1*, 655–667.
- Gao, F.; Wang, Y.; Shi, D.; Zhang, J.; Wang, M.; Jing, X.; Humphry-Baker, R.; Wang, P.; Zakeeruddin, S. M.; Grätzel, M. Enhance the optical absorptivity of nanocrystalline TiO<sub>2</sub> film with high molar extinction coefficient ruthenium sensitizers for high performance dye-sensitized solar cells. *J. Am. Chem. Soc.* **2008**, *130*, 10720–10728.
- Gerischer, H.; Michel-Beyerle, M. E.; Rebentrost, F.; Tributsch, H. Sensitization of charge injection into semiconductors with large band gap. *Electrochim. Acta* **1968**, *13*, 1509–1515.
- Gerischer, H.; Willig, F. Reaction of excited dye molecules at electrodes. *Top. Curr. Chem.* **1976**, *61*, 31–84.
- Memming, R.; Tributsch, H. Electrochemical investigations on the spectral sensitization of gallium phosphide electrodes. *J. Phys. Chem.* **1971**, *75*, 562–570.
- Stora, C. The part played by dyestuffs in photovoltaic phenomena. *J. Chim. Phys. Phys.-Chim. Biol.* **1932**, *29*, 168–183.
- Nakabayashi, S.; Ohta, N.; Fujishima, A. Dye sensitization of synthetic p-type diamond electrode. *Phys. Chem. Chem. Phys.* **1999**, *1*, 3993–3997.
- Fernando, C. A. N.; Kitagawa, A.; Suzuki, M.; Takahashi, K.; Komura, T. Photoelectrochemical properties of rhodamine-C18 sensitized p-CuSCN photoelectrochemical cell (PEC). *Sol. Energy Mater. Sol. Cells* **1994**, *33*, 301–315.
- Tennakone, K.; Kumarasinghe, A. R.; Sirimanne, P. M.; Kumara, G. R. R. A. Deposition of thin polycrystalline films of cuprous thiocyanate on conducting glass and photoelectrochemical dye-sensitization. *Thin Solid Films* **1995**, *261*, 307–310.
- He, J.; Lindström, H.; Hagfeldt, A.; Lindquist, S.-E. Dye-sensitized nanostructured p-type nickel oxide film as a photocathode for a solar cell. *J. Phys. Chem. B* **1999**, *103*, 8940–8943.
- Jose, R.; Kumar, A.; Thavasi, V.; Fujihara, K.; Uchida, S.; Ramakrishna, S. Relationship between the molecular orbital structure of the dyes and photocurrent density in the dye-sensitized solar cells. *Appl. Phys. Lett.* **2008**, *93*, 023125/1–023125/3.
- Natstead, A.; Ferguson, M.; Kerr, R.; Cheng, Y.-B.; Bach, U. Dye-sensitized nickel(II)oxide photocathodes for tandem solar cell applications. *Nanotechnology* **2008**, *19*, 295304.
- Qin, P.; Zhu, H.; Edvinsson, T.; Boschloo, G.; Hagfeldt, A.; Sun, L. Design of an Organic chromophore for p-type dye-sensitized solar cells. *J. Am. Chem. Soc.* **2008**, *130*, 8570–8571.
- Mizoguchi, Y.; Fujihara, S. Fabrication and dye-sensitized solar cell performance of nanostructured NiO/coumarin 343 photocathodes. *Electrochem. Solid-State Lett.* **2008**, *11*, K78–K80.



- 18 Mori, S.; Fukuda, S.; Sumikura, S.; Takeda, Y.; Tamaki, Y.; Suzuki, E.; Abe, T. Charge-transfer processes in dye-sensitized NiO solar cells. *J. Phys. Chem. C* **2008**, *112*, 16134–16139.
- 19 Lepleux, L.; Chavillon, B.; Pellegrin, Y.; Blart, E.; Cario, L.; Jobic, S.; Odobel, F. Simple and reproducible procedure to prepare self-nanostructured NiO films for the fabrication of p-type dye-sensitized solar cells. *Inorg. Chem.* **2009**, *48*, 8245–8250.
- 20 Nakasa, A.; Usami, H.; Sumikura, S.; Hasegawa, S.; Koyama, T.; Suzuki, E. A high voltage dye-sensitized solar cell using a nanoporous NiO photocathode. *Chem. Lett.* **2005**, *34*, 500–501.
- 21 Qin, P.; Linder, M.; Brinck, T.; Boschloo, G.; Hagfeldt, A.; Sun, L. high incident photon-to-current conversion efficiency of p-type dye-sensitized solar cells based on NiO and organic chromophores. *Adv. Mater.* **2009**, *21*, 2993–2996.
- 22 Nattestad, A.; Mozer, A. J.; Fischer, M. K. R.; Cheng, Y. B.; Mishra, A.; Bäuerle, P.; Bach, U. Highly efficient photocathodes for dye-sensitized tandem solar cells. *Nat. Mater.* **2010**, *9*, 31–35.
- 23 Borgström, M.; Blart, E.; Boschloo, G.; Mukhtar, E.; Hagfeldt, A.; Hammarström, L.; Odobel, F. Sensitized hole injection of phosphorus porphyrin into NiO: Toward new photovoltaic devices. *J. Phys. Chem. B* **2005**, *109*, 22928–22934.
- 24 Lin, L.; Elizabeth, A. G.; Peng, Q.; Gerrit, B.; Mikhail, G.; Anders, H.; Licheng, S. Double-layered NiO photocathodes for p-type DSSCs with record IPCE. *Adv. Mater.* **2010**, *22*, 1759–1762.
- 25 Wasielewski, M. R. Energy, charge, and spin transport in molecules and self-assembled nanostructures inspired by photosynthesis. *J. Org. Chem.* **2006**, *71*, 5051–5066.
- 26 Morandeira, A.; Fortage, J.; Edvinsson, T.; Le Pleux, L.; Blart, E.; Boschloo, G.; Hagfeldt, A.; Hammarström, L.; Odobel, F. Improved photon-to-current conversion efficiency with a nanoporous p-type NiO electrode by the use of a sensitizer-acceptor dyad. *J. Phys. Chem. C* **2008**, *112*, 1721–1728.
- 27 Jose, R.; Thavasi, V.; Ramakrishna, S. Metal oxides for dye-sensitized solar cells. *J. Am. Ceram. Soc.* **2009**, *92*, 289–301.
- 28 Dare-Edwards, M. P.; Goodenough, J. B.; Hamnett, A.; Nicholson, N. D. Photoelectrochemistry of nickel(II) oxide. *J. Chem. Soc., Faraday Trans. 2* **1981**, *77*, 643–661.
- 29 Adler, D.; Feinleib, J. Electrical and optical properties of narrow-band materials. *Phys. Rev. B* **1970**, [3]2, 3112–3134.
- 30 He, J.; Lindström, H.; Hagfeldt, A.; Lindquist, S. E. Dye-sensitized nanostructured tandem cell - first demonstrated cell with a dye-sensitized photocathode. *Sol. Energy Mater. Sol. Cells* **2000**, *62*, 265–273.
- 31 Boschloo, G.; Hagfeldt, A. Spectroelectrochemistry of nanostructured NiO. *J. Phys. Chem. B* **2001**, *105*, 3039–3044.
- 32 Velevska, J.; Ristova, M. Electrochromic properties of NiOx prepared by low vacuum evaporation. *Sol. Energy Mater. Sol. Cells* **2002**, *73*, 131–139.
- 33 Vera, F.; Schrebler, R.; Munoz, E.; Suarez, C.; Cury, P.; Gomez, H.; Cordova, R.; Marotti, R. E.; Dalchiele, E. A. Preparation and characterization of eosin B- and erythrosin J-sensitized nanostructured NiO thin film photocathodes. *Thin Solid Films* **2005**, *490*, 182–188.
- 34 Kuang, D.-B.; Lei, B.-X.; Pan, Y.-P.; Yu, X.-Y.; Su, C.-Y. Fabrication of novel hierarchical  $\beta$ -Ni(OH)<sub>2</sub> and NiO microspheres via an easy hydrothermal process. *J. Phys. Chem. C* **2009**, *113*, 5508–5513.
- 35 Xi, Y. Y.; Li, D.; Djuricic, A. B.; Xie, M. H.; Man, K. Y. K.; Chan, W. K. Hydrothermal synthesis vs electrodeposition for high specific capacitance nanostructured NiO films. *Electrochem. Solid-State Lett.* **2008**, *11*, D56–D59.
- 36 Urbano, A.; Ferreira, F. F.; deCastro, S. C.; Landers, R.; Fantini, M. C. A.; Gorenstein, A. Electrochromism in lithiated nickel oxide films deposited by rf sputtering. *Electrochim. Acta* **2001**, *46*, 2269–2273.
- 37 Park, J.-Y.; Ahn, K.-S.; Nah, Y.-C.; Shim, H.-S.; Sung, Y.-E. Electrochemical and electrochromic properties of Ni oxide thin films prepared by a sol-gel method. *J. Sol-Gel Sci. Technol.* **2004**, *31*, 323–328.
- 38 Sumikura, S.; Mori, S.; Shimizu, S.; Usami, H.; Suzuki, E. Syntheses of NiO nanoporous films using nonionic triblock co-polymer templates and their application to photo-cathodes of p-type dye-sensitized solar cells. *J. Photochem. Photobiol., A* **2008**, *199*, 1–7.
- 39 Zhu, H.; Hagfeldt, A.; Boschloo, G. Photoelectrochemistry of mesoporous NiO electrodes in iodide/triiodide electrolytes. *J. Phys. Chem. C* **2007**, *111*, 17455–17458.
- 40 Duffy, N. W.; Peter, L. M.; Rajapakse, R. M. G.; Wijayantha, K. G. U. Investigation of the kinetics of the back reaction of electrons with tri-iodide in dye-sensitized nanocrystalline photovoltaic cells. *J. Phys. Chem. B* **2000**, *104*, 8916–8919.
- 41 Gregg, B. A.; Pichot, F.; Ferrere, S.; Fields, C. L. Interfacial recombination processes in dye-sensitized solar cells and methods to passivate the interfaces. *J. Phys. Chem. B* **2001**, *105*, 1422–1429.
- 42 Splan, K. E.; Massari, A. M.; Hupp, J. T. A porous multilayer dye-based photoelectrochemical cell that unexpectedly runs in reverse. *J. Phys. Chem. B* **2004**, *108*, 4111–4115.
- 43 Morandeira, A.; Boschloo, G.; Hagfeldt, A.; Hammarström, L. Photoinduced ultrafast dynamics of coumarin 343 sensitized p-type-nanostructured NiO films. *J. Phys. Chem. B* **2005**, *109*, 19403–19410.
- 44 Morandeira, A.; Boschloo, G.; Hagfeldt, A.; Hammarström, L. Coumarin 343-NiO films as nanostructured photocathodes in dye-sensitized solar cells: Ultrafast electron transfer, effect of the  $I^3^-/I^-$  redox couple and mechanism of photocurrent generation. *J. Phys. Chem. C* **2008**, *112*, 9530–9537.
- 45 Qin, P.; Wiberg, J.; Gibson, E. A.; Linder, M.; Li, L.; Brinck, T.; Hagfeldt, A.; Albinsson, B.; Sun, L. Synthesis and mechanistic studies of organic chromophores with different energy levels for p-type dye-sensitized solar cells. *J. Phys. Chem. C* **2010**, *114*, 4738–4748.
- 46 Bolton, J. R.; Strickler, S. J.; Connolly, J. S. Limiting and realizable efficiencies of solar photolysis of water. *Nature* **1985**, *316*, 495–500.
- 47 Gibson, E. A.; Smeigh, A. L.; Pleux, L. L.; Fortage, J.; Boschloo, G.; Blart, E.; Pellegrin, Y.; Odobel, F.; Hagfeldt, A.; Hammarström, L. A p-type NiO-based dye-sensitized solar cell with a Voc of 0.35 V. *Angew. Chem., Int. Ed.* **2009**, *48*, 4402–4405.