

In the above titration we get the output, generally, as current, conductivity, etc., so we must change these output to voltage proportional to these output before the differentiation, and these changes have many difficulties. So, the automation of the above titration by higher differentiation is not considered a good method.

The author thanks Prof. Seishi Takagi of the University of Kyoto and Dr. Saburo Kakinuma, President of the Osaka College of Pharmacy, for their interest and encouragement in this work, and Assist. Prof. Bunji Kondo, Electrical Engineering Dept., Engineering Faculty, University of Kyoto, for kind suggestions in this work.

Summary

In the titration with a titration curve as in Fig. II-1, it is the best to use the 2nd derivative voltage as the triggering signal and the 1st derivative voltage may be used, too.

In the titration with a titration curve as in Fig. II-2, the 3rd or the 4th derivative voltages could be used for the automatic titration, but by the above reasons, it is not a good method.

(Received February 11, 1956)

U. D. C. 545.37.084

62. Yoshihiro Maekawa : Studies on the Higher Derivative Automatic Titration. III.¹⁾ The 3rd Derivative Automatic Titrator, AT-V, and Results of Titration with AT-V.

(Osaka College of Pharmacy, and The Institute for Chemical Research, University of Kyoto)*

In the preceding paper,²⁾ it was shown that in the normal potentiometric titration, it is the best to use the 3rd derivative voltage as the triggering signal.

This paper deals with the 3rd derivative automatic titrator, AT-V, and the results obtained with it.

Figs. III-1, III-2, and III-3 respectively show the electrical wiring diagram of AT-V, the exterior view of AT-V, and mechanism of the magnetic cock used in AT-V.

The principle of AT-V is the same as that of the 2nd derivative automatic titrator, AT-III.³⁾ The electromotive force, which is obtained from the titration vessel, is added to the high-pass filter which is constructed with two resistors, 250 k Ω each, and a condenser, 2 μ F. Then it is amplified and differentiated with *R-C* differentiation network. The amplification and the differentiation are repeated three times, thus the 3rd derivative voltage, is obtained. For the amplifiers, differential amplifiers are used to decrease the hum and increase the gain in low frequency range. The negative feedback, which is constructed with two 250 pF condensers, *C*₂'s, and effective in high frequency range, are also used to decrease the hum. The 3rd derivative output voltage is amplified, then put on the cathode follower circuits for decreasing the direct current level and impedance. The output voltage, adjustable by VR₂ and VR₃, are used for the triggering voltage of the thyratrons. The thyratrons, 66G-GT's, are operated by alternating current, though in the 2nd derivative automatic titrators, AT-I, -II,

* Kitayashitamura, Minamikawachi-gun, Osaka-fu (前川義裕).

1) Part II : This Bulletin, 4, 325(1956).

2) Part I : This Bulletin, 4, 321(1956).

3) Y. Maekawa : Japan Analyst, 3, 489(1954).

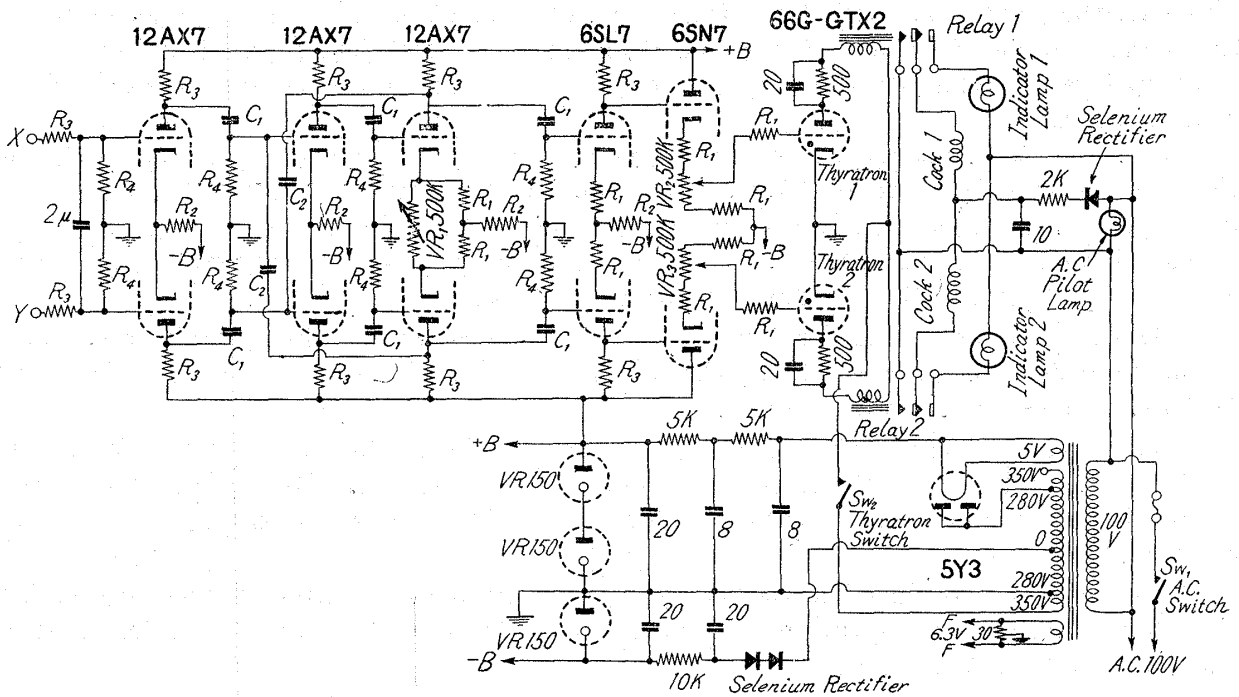

Fig. III-1. Wiring Diagram of 3rd Derivative Automatic Titrator

3rd Derivative Automatic Titrator (AT-V)

- VR₁ : Sensitivity control VR₂, VR₃ : Thyatron operating voltage control
- X, Y : Input terminals for electrode
- R₁ : 50 kΩ R₂ : 100 kΩ R₃ : 250 kΩ R₄ : 500 kΩ C₁ : 0.5 μF C₂ : 250 μF

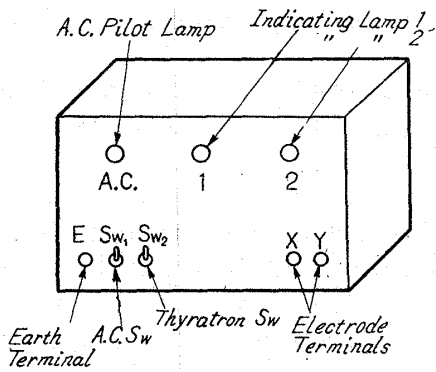

Fig. III-2. Outside View of AT-V

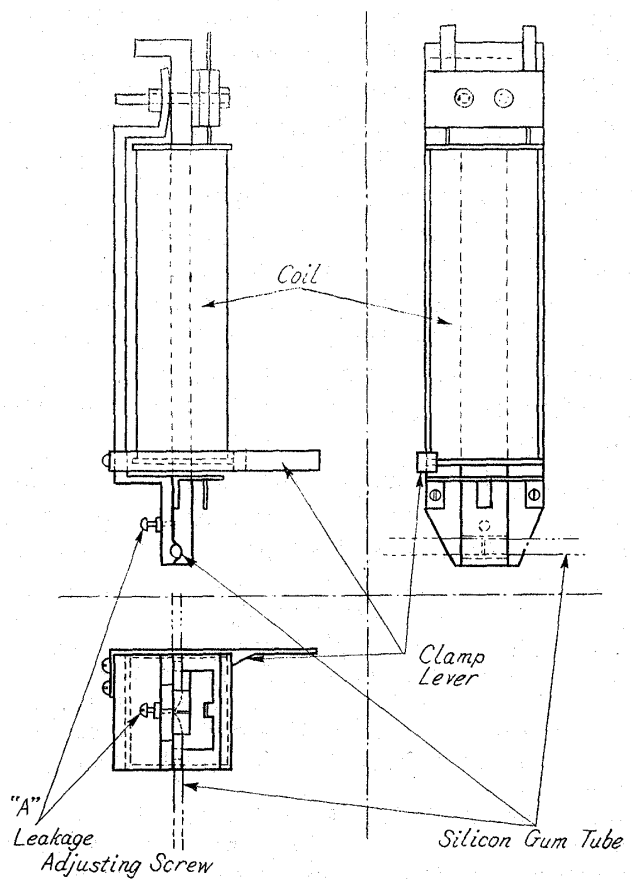

Fig. III-3. Magnetic Cock

and -III, they were operated by direct current. So, if the input voltage goes down to the firing voltage after once firing, the thyatron will stop the firing. For this reason, a clamp lever is added to the magnetic cocks for holding the cocks at closed position after once firing.

D. C. and A. C. operations of the thyatron each have merits and demerits, but this titrator was designed for A. C. operation. Because the titrator was designed for mass production and has comparatively simple power supply than AT-III, if the thyatron firing takes a large current from the power supply, it will cause the output voltage variation and the titrator will lose stability.

The power supply was constructed with 5 Y3 selenium rectifier and filters. The output voltages are stabilized with three constant voltage glow-tubes, VR-150's, and +300 v. and -150 v. were obtained.

The magnetic cock is shown in Fig. III-3 and it is smaller and valid than that of the AT-III. The magnetic cock No. 1 has little leakage (which is adjustable by screw A in Fig. III-3) at a closed position and the cock No. 2 has no leakage at a closed position.

This titrator was used as the 3rd derivative automatic titrator in this study, but it is usable as the 2nd derivative automatic titrator by omitting one *R-C* differentiation and one amplification stage.

The operation processes of this titrator are as follows :

1) Turn on the A. C. switch, Sw₁, stand few minutes to wait for the operation of the vacuum tubes.

2) Turn on the thyatron switch, Sw₂, then adjust VR₂ and VR₃, the variable resistances for adjusting the firing voltage of the thyatrons, for firing, and then somewhat back them and stop the firing. The operation of the thyatrons, and then the magnetic cocks too, are shown by lighting of the indicator lamps. This adjustment is not needed after the first adjustment.

3) Connect the proper electrodes, which are, for example, a platinum and calomel electrodes, to the electrode terminals. The electromotive force between the electrodes must change as Fig. I-4, during the titration.

4) Open the magnetic cocks by hand, and titrate and watch the indicator lamps on the panel. When the indicator lamp No. 1 lights first, then the lamp No. 2, the titration will be proceeding correctly. When the lamp No. 2 lights first then the lamp No. 1, titration will be going incorrectly, and the connection of the electrodes must be reversed. The indicator lamps will go out after the indication of the cock operation, so the lamps must be watched carefully.

5) After the automatic stop of the titration, read the volume of the titrating solution used.

From the above operation process, it will be easily seen that it is unnecessary to adjust the titrator after a simple adjustment at first operation, and this is the greatest advantage of the higher derivative automatic titration.

Some results obtained with this titrator will be described below.

(I) System of 0.1N Na₂S₂O₃-0.1N I₂.

(0.1N Na₂S₂O₃ 20.00 cc.+H₂O 10 cc.+starch solution, a few drops) was titrated automatically with 0.1N I₂. After the automatic stop, the excess was back titrated by hand with 0.1N Na₂S₂O₃. Let *v* cc. be the volume of 0.1N I₂ used and *dv*₁ cc. be the volume of back titrated 0.1N Na₂S₂O₃. Then, a few cc. of 0.1N Na₂S₂O₃ is added, titrated automatically with 0.1N I₂, and back titrated as above. Let this volume be *dv*₂ cc., and so on. The electrodes used were a platinum and a calomel electrode.

The standard deviation of *v* will show the overall titration errors, including those of volume measuring, titrator, etc., and the standard deviation of *dv* will show the titration errors depending only on this automatic titration, because the color change of starch solution is very sharp in this

concentration of the titrating solution.

The measured values for v were as follows: 19.15, 19.20, 19.10, 19.10, 19.15 cc.

The time used for each titration was about 2~6 mins.

The titration error which was calculated from 25 measurements of dv was as follows:

The standard deviation of dv : $\sigma=0.019$ cc.

The mean of dv : $\bar{dv}=0.04$ cc.

The titration error = $0\sim+0.4\%$ (95% confidence limits)

(II) System of 0.01N $\text{Na}_2\text{S}_2\text{O}_3$ -0.01N I_2 .

The titration same as (I) was carried out with 0.01N solution. The measured values for v was as follows: 21.20, 21.10, 21.15, 21.05, 21.12 cc.

The time used for each titration was about 2 mins.

The titrating error calculated from 25 measurements of dv was as follows:

$\sigma=0.016$ cc. $\bar{dv}=0.03$ cc.

The titration error = $0\sim+0.3\%$ (95% confidence limits)

(III) System of 0.001N $\text{Na}_2\text{S}_2\text{O}_3$ -0.001N I_2 .

The titration same as (I) was carried out with 0.001N solution, but, in this titrations, the color change of starch solution was not clear, that dv was not measured.

The measured values for v was as follows: 20.70, 20.70, 20.70, 20.80, 20.70 cc.

The time used for each titration was about 2~4 mins.

(IV) System 0.067N HCl-0.1N NaOH.

(0.067N HCl 20.00 cc. + H_2O 10 cc. + few drops of methyl orange solution) was titrated automatically with 0.1N NaOH, 15 times. Let v be this volume. The same titration was carried out by hand a few times. Let v_0 be this volume. An antimony and a calomel electrodes were used.

The measured values for v were as follows: 13.60, 13.70, 13.70, 13.72, 13.77, 13.78, 13.80, 13.82, 13.70, 13.72, 12.75, 13.78, 13.88, 13.75, 13.82 cc.

The measured values for v_0 were as follows: 13.75, 13.76, 13.75 cc.

The mean of $v_0 = \bar{v}_0 = 13.75$ cc.

The standard deviation $dv (=v - \bar{v}_0) = 0.064$ cc.

The mean of $dv = 0.03$ cc.

The titration error calculated from $dv = -0.9\% \sim +0.9\%$ (95% confidence limits)

(V) System of 0.1N NaOH-0.1N HCl.

(0.1N NaOH 20.00 cc. + H_2O 10 cc. + few drops of methyl orange solution) was titrated automatically with 0.1N HCl, 10 times. The same titration was carried out by hand a few times. The others are same as (VI).

The standard deviation of $dv = 0.073$ cc.

The mean of $dv = 0.132$ cc.

The titration error calculated from $dv = 0 \sim +1.4\%$ (95% confidence limits).

(VI) System of 0.1N NH_4OH -0.1N HCl.

(0.1N NH_4OH 20.00 cc. + few drops of methyl orange solution) was titrated automatically with 0.1N HCl, 13 times. The same titration was carried out by hand a few times. The others are the same as (IV).

The standard deviation of $dv = 0.05$ cc.

The mean of $dv = 0.04$ cc.

The titration error which was calculated from $dv = -0.3\% \sim +0.7\%$ (95% confidence limits).

(VII) System of 0.1N AcOH-0.1N NaOH.

(0.1N AcOH 20.00 cc. + phenolphthalein solution, a few drops) was titrated automatically with 0.1N NaOH,

10 times. The same titration was carried out by hand a few times. The others are the same as (IV).

The standard deviation of $dv = 0.056$ cc.

The mean of $dv = 0.081$ cc.

The titration error from $dv = -0.2\% \sim +1.1\%$ (95% confidence limits).

The author desires to thank Prof. Seishi Takagi, University of Kyoto, and President Saburo Kakinuma, The Osaka College of Pharmacy, for the interest and encouragement in this work. This work was financed by a Grant in Aid for Scientific Research from the Ministry of Education to which the author is also indebted.

Summary

The author made the 3rd derivative automatic titrator, AT-V (Fig. III-1), based on the result given in the Part I of this series,²⁾ and many titrations were carried out with this titrator. The results show that the titrator may be used for many industrial and experimental analyses.

(Received February 11, 1956)