

**Drug Absorption, Metabolism, and Excretion. VII.<sup>1)</sup> Pharmacokinetics  
on Formation and Excretion of the Conjugates  
of N-Acetyl-*p*-aminophenol in Rabbits<sup>2)</sup>**

JUICHIRO SHIBASAKI, RYOJI KONISHI, YOSHINORI TAKEDA<sup>3a)</sup>  
and TAMOTSU KOIZUMI<sup>3b)</sup>

*Faculty of Pharmaceutical Sciences, Nagasaki University<sup>3a)</sup> and  
Faculty of Pharmaceutical Sciences, Toyama University<sup>3b)</sup>*

(Received January 11, 1971)

Pharmacokinetics on the formation and the excretion of the conjugates following rapid intravenous injection of N-acetyl-*p*-aminophenol (NAPA) was investigated in rabbits. In conflict with the assumption made by Nelson and Morioka in man that each excretion of the NAPA conjugates (glucuronide and sulfate) after dosage of NAPA would be rate-limited by each formation step, it was confirmed in rabbits that the formation step of the conjugates progressed much more rapidly than the subsequent excretion step. Furthermore, making a simplification that the two NAPA conjugates might be treated single since the glucuronide is predominant, the model fitting to the blood levels of free NAPA and the conjugate and the excreted amounts of the conjugate in the urine was elucidated, which consisted of a three-step consecutive first order process, the first step of which was the formation of the conjugate, the second the transfer of the conjugate from the blood to a hypothetical compartment, and the third urinary excretion of the conjugate through the intervenient compartment and two competitive first order processes, respectively, for the second step of the three-step consecutive process mentioned above and the direct urinary excretion of the conjugate from the blood.

In man and rabbit, N-acetyl-*p*-aminophenol (NAPA) is known to be excreted almost completely as the conjugates with glucuronic acid and sulfuric acid and hardly as the intact form. Some pharmacokinetics of the metabolism and the excretion of this substance have also been studied previously in man<sup>4)</sup> and rabbit.<sup>5)</sup> All investigators of these works made the interpretation only from the urinary excretion data after oral administration of NAPA.<sup>6)</sup> Nelson and Morioka<sup>4a)</sup> have estimated the sum of the formation rate constants of the two NAPA conjugates under the assumption that each excretion rate of the conjugates would be much greater than respective formation rate. Although this assumption is favorable for estimating the rate constants relating to the formation and/or the excretion of the conjugates, no experimental evidences were presented by them. Cummings, *et al.*<sup>4b)</sup> have obtained the rate constants not only for the formation but also for the excretion of each conjugate. They calculated the excretion rate constants by two methods; "Rate v. Amount" method<sup>7)</sup> is less reliable because it depends on free NAPA excreted in very small quantity and "Terminal Ratio" method<sup>7)</sup> contains the uncertainty due to the same assumption as Nelson and Morioka<sup>4a)</sup>

- 1) Part VI: J. Shibasaki, E. Sadakane, R. Konishi and T. Koizumi, *Chem. Pharm. Bull.* (Tokyo), **18**, 2340 (1970).
- 2) A part of this work was presented at the 89th Annual Meeting of the Pharmaceutical Society of Japan, Nagoya, April, 1969.
- 3) Location: a) 1-14 Bunkyo-machi, Nagasaki; b) 3150 Gofuku, Toyama.
- 4) a) E. Nelson and T. Morioka, *J. Pharm. Sci.*, **52**, 864 (1963); b) A. J. Cummings, M. L. King and B.K. Martin, *Brit. J. Pharmacol.*, **29**, 150 (1967).
- 5) H.G. Bray, W.V. Thorpe and K. White, *Biochem. J.*, **52**, 423 (1952).
- 6) The route of administration employed by Cummings, *et al.*<sup>4b)</sup> has not been described in their report but it is supposed to be oral route.
- 7) These are the designation employed by Cummings, *et al.*<sup>4b)</sup>

made. Bray, *et al.*<sup>5)</sup> have determined the rate constant for the glucuronide formation in rabbits assuming alike Nelson and Morioka<sup>4a)</sup> without sufficient evidences. Thus, it is obvious that the rate constants relating to the pharmacokinetics of NAPA reported until now remain to be further examined. In the previous work on NAPA kinetics<sup>8)</sup> after intravenous dosage of NAPA reported by some of the present authors, where the urinary data alone available, the overall processes of the formation and the excretion of the conjugated NAPA were considered to be interpreted practically by a single first order kinetics and  $0.659 \text{ hour}^{-1}$  was assigned as the rate constant without indicating the rate-limiting step for the reason pointed out above.

The present investigations were undertaken to clarify each rate constant involved in the processes of the formation and the excretion of the conjugates based on the data of not only the amounts of total NAPA in the urine but also free and conjugated NAPA levels in the blood after rapid intravenous administration of NAPA to rabbits.

### Experimental

**Animal**—Unanesthetized male albino rabbits weighing 2.5 to 3.5 kg were used. NAPA was dissolved in saline to make 300 mg/10 ml solution which was administered by rapid intravenous injection through the ear vein. Blood specimens were taken as many times as possible at the arbitrary intervals with a syringe containing 3.8% sodium citrate solution from the ear vein or heart. Urine collections were made hourly through Nelaton's catheter inserted into the bladder. Food was withheld during the experiments, although water was given through the stomach tube frequently to keep the urine flow constant.

**Drug**—NAPA used was of J.P. grade.

**Analytical Methods**—Free NAPA and the sum of free and conjugated NAPA in the blood and the latter in the urine were estimated by the method described by Brodie and Axelrod<sup>9)</sup> with a slight modification only on the volume of the solvent used. Conjugated NAPA in the blood was calculated by subtracting free NAPA from the sum of free and conjugated NAPA.

**Computer Analysis**—An analog computer (Hitachi ALS 505) and a X-Y recorder (Watanabe WX 431) were used.

### Result and Discussion

It has been shown previously<sup>8)</sup> that the glucuronide was major metabolite accounting for over 90% of the dose administered and the corresponding values for the sulfate and unchanged NAPA were 4–7% and 1%, respectively, when 300 mg of NAPA was given intravenously to rabbits. Taking these factors into consideration, the excretion of unchanged NAPA was neglected and the two conjugates were considered as a single conjugate in the present studies. Then, the simplest model describing the conjugation and the excretion after the administration of NAPA would be Model I.

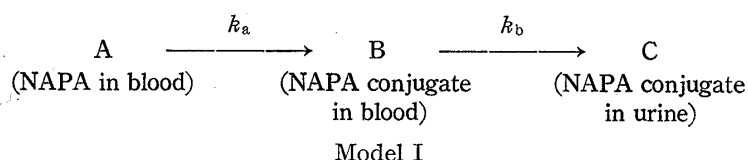

where A, B, and C are the designation of each compartment,  $k_a$  is the first order rate constant for the formation of the conjugate and  $k_b$  is that for the excretion of the conjugate. Interpretation on the experimental data of each compartment is carried out in the following sections.<sup>10)</sup>

8) J. Shibasaki, T. Koizumi and T. Tanaka, *Chem. Pharm. Bull.* (Tokyo), **16**, 1661 (1968).

9) B.B. Brodie and J. Axelrod, *J. Pharmacol. Exptl. Therap.*, **94**, 22 (1948).

10) Though the shift in zero time was made in the previous work<sup>8)</sup> to allow interpretation of data in the post-equilibrative times, such adjustment was not done in the present studies as the time necessary for attaining to the equilibrium seemed not so large and the decrease of the data points accompanied was considered to be rather unfavorable.

### Elimination of Unchanged NAPA from the Blood

The blood levels of unchanged NAPA ( $\bar{A}$ ) after intravenous dosage of 300 mg of NAPA are presented in Table I.  $\bar{A}$  according to Model I may be expressed:

$$\bar{A} = \bar{A}_0 e^{-k_a t} \quad (1)$$

where  $\bar{A}_0$  is the blood level of NAPA at  $t=0$ . Logarithmic form of equation (1) is:

$$\log \bar{A} = \log \bar{A}_0 - \frac{k_a t}{2.303} \quad (2)$$

The values in Table I were plotted on a semi-logarithmic scale against time, and the examples of the resulting graphs are shown in Fig. 1. They can be approximately assumed as linear, which indicates that the elimination of NAPA from the blood, that is, the formation of the NAPA conjugate can be simulated by equation (2). The rate constants ( $k_a$ ) obtained from the slopes of the graphs of the rabbits examined are shown in Table IV, the mean value of which being 2.34 hour<sup>-1</sup>.

TABLE I. Blood Levels of NAPA ( $\bar{A}$ ) at Various Times after Intravenous Administration of NAPA (300 mg) to Rabbits

Rabbits	Time and blood levels of NAPA										
F	time (hr)	0.17	0.33	0.52	0.78	1.17					
	$\bar{A}$ (mg %)	6.30	3.89	2.71	1.61	0.80					
J	time (hr)	0.17	0.33	0.55	0.68	0.98					
	$\bar{A}$ (mg %)	7.20	3.89	2.50	1.91	0.99					
K	time (hr)	0.17	0.33	0.53	0.75	0.87	1.47				
	$\bar{A}$ (mg %)	7.93	6.03	4.03	2.55	2.77	0.99				
P	time (hr)	0.15	0.30	0.45	0.58	0.73	0.92	1.07	1.25	1.42	
	$\bar{A}$ (mg %)	8.30	4.96	3.91	3.53	3.13	2.24	1.59	1.06	0.90	
S	time (hr)	0.17	0.25	0.33	0.43	0.52	0.60	0.68	0.77	0.85	
	$\bar{A}$ (mg %)	6.72	4.20	3.24	2.82	2.33	1.79	1.18	1.28	1.07	
Z	time (hr)	0.08	0.25	0.37	0.50	0.62					
	$\bar{A}$ (mg %)	7.22	3.43	2.81	1.90	1.37					

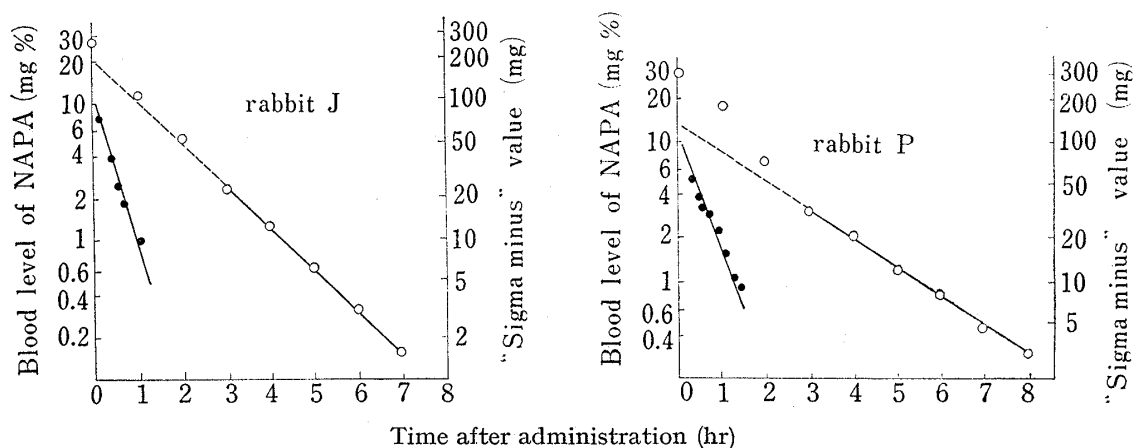

Fig. 1. Logarithmic Plots of the Blood of NAPA (●) and "Sigma Minus" Values (○) after *i. v.* Administration of NAPA 300 mg

The solid lines were drawn for the linear portions in log "Sigma minus" plots.

### Excretion of the Conjugate in the Urine

The cumulative amounts of the NAPA conjugate excreted ultimately ( $A_0$ ) minus that excreted at each time ( $C_a$ ) will be hereafter termed "Sigma minus" after Cummings, *et al.*<sup>11)</sup>

11) A.J. Cummings, B.K. Martin and G.S. Park, *Brit. J. Pharmacol.*, **29**, 136 (1967).

$A_0$  may be equal to the amounts administered, if the recovery in the urine being complete. "Sigma minus" according to Model I may be expressed:

$$A_0 - C_a = \frac{A_0}{k_b - k_a} (k_b e^{-k_a t} - k_a e^{-k_b t}) \quad (3)$$

If  $k_b$  is much greater than  $k_a$ , as assumed by Nelson and Morioka,<sup>4a)</sup> equation (3) reduces to:

$$A_0 - C_a = \frac{k_b A_0}{k_b - k_a} e^{-k_a t} \quad (4)$$

Logarithmic form of equation (4) is described by:

$$\log(A_0 - C_a) = \log \frac{k_b A_0}{k_b - k_a} - \frac{k_a t}{2.303} \quad (5)$$

Comparing equation (2) with equation (5), it is apparent that  $\log \bar{A}$  plots and  $\log$  "Sigma minus" plots eventually would become parallel and show the slope corresponding to  $k_a$ .

The hourly cumulative amounts of the conjugated NAPA excreted in the urine ( $C_a$ ) up to 10 hours after intravenous dosage of 300 mg of NAPA are given in Table II, for which  $\log$  "Sigma minus" plots against time were examined.

TABLE II. Cumulative Amounts( $C_a$ ) of Conjugated NAPA excreted in Urine at Various Times after Intravenous Administration of NAPA (300 mg) to Rabbits

Rabbits	Cumulative amounts excreted (mg)									
	(hr) 1	2	3	4	5	6	7	8	9	10
F	126.7	200.0	227.0	243.0	249.5	253.2	254.9	256.1	257.0	257.6
J	143.9	205.2	234.9	244.8	251.2	254.3	255.8	256.7	257.0	257.3
K	121.9	176.9	209.9	220.3	239.0	244.0	245.7	247.7	248.7	249.4
P	123.0	231.4	269.8	282.5	290.8	294.9	298.4	300.1	302.0	303.2
S	80.9	190.0	243.5	262.4	275.9	282.3	286.2	288.5	289.7	290.3
Z	161.1	237.2	257.4	262.4	268.9	271.7	273.4	274.3	275.0	275.4

In stead of  $A_0$ , the present authors used the cumulative amounts of the NAPA conjugate excreted up to the terminal hour of the experiments, since the excretion of the NAPA conjugate was considered to be completed practically by that time judging from the data in Table II. Since the errors of "Sigma minus" due to the underestimation of  $A_0$  in this way should become greater as the time approached the terminal hour,  $\log$  "Sigma minus" plots were given up 8 hours after the administration. The plots thus obtained afford some complicated curvatures during about first 3 hours of the experiments and then become linear as shown in Fig. 1.<sup>12)</sup> The slopes of the linear parts of  $\log$  "Sigma minus" plots are obviously distinguishable from those of  $\log \bar{A}$ , the former being much smoother than the latter. This fact indicates that the excretion of the conjugate after dosage of NAPA is not rate-limited by the step of the formation of the conjugate, but by the subsequent step relating to the excretion, which is inconsistent with the assumption made by Nelson and Morioka<sup>4a)</sup> in man. The rate constants ( $k_b$ ) obtained from the slopes of the linear parts of the graphs for the rabbits examined are shown in Table IV, the mean value of which being  $0.61 \text{ hour}^{-1}$ .

12) Although in the previous studies,<sup>8)</sup> the  $\log$  "Sigma minus" plots have been simply interpreted as linear, strictly speaking, the same complicated curvatures as pointed out here were observed at the earlier period of the plots.

Subsequently, the fit of Model I to the observed data of  $C_a$  was examined by an analog computer using the set of values for  $A_0$ ,  $k_a$ , and  $k_b$  presented above. The comparisons of the theoretical and experimentally observed values of  $C_a$  are shown in Fig. 2. Good agreement can not be seen in all the rabbits except rabbit S. The calculated curves keep on tracing far below the experimental data points up to just before the terminal hour. Therefore, it was anticipated that the excretion kinetics of the NAPA conjugate would not be so simple as described by Model I.

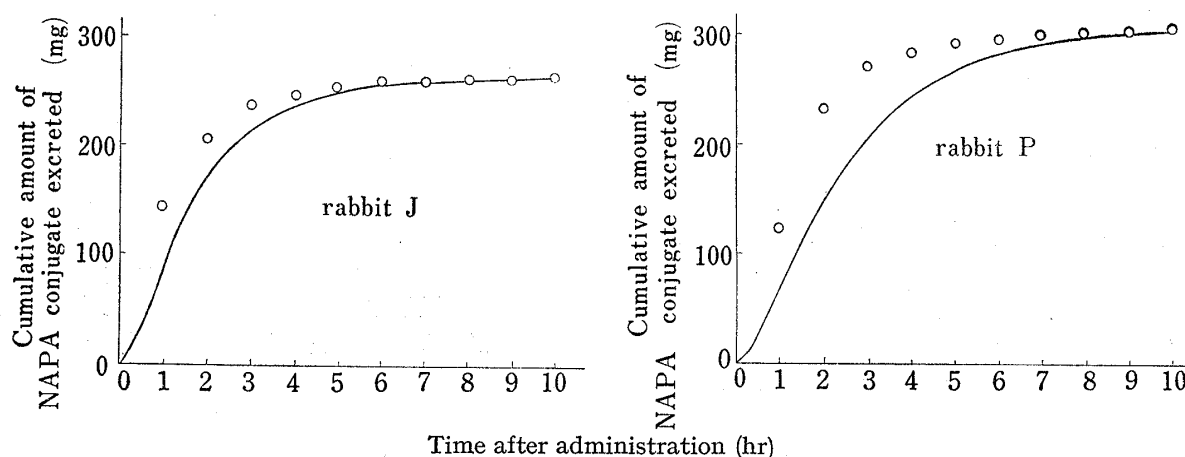

Fig. 2. Cumulative Excretion of NAPA Conjugate Obtained Theoretically according to Model I and Those Observed Experimentally

Solid lines are theoretical values and plotted points (O) are experimental values. Good agreement was not seen except in rabbit S.

### Blood Levels of the Conjugate

The blood levels of the NAPA conjugate ( $\bar{B}$ ) are shown in Table III. The fit of Model I to the observed  $\bar{B}$  was examined by an analog computer using the same values of parameters as described in the previous sections. In order to obtain the theoretical values of  $\bar{B}$ , it was necessary to determine the volume of distribution of the NAPA conjugate ( $V_B$ ) (*i.e.*  $\bar{B} =$  amounts of NAPA conjugate in the compartment  $B/V_B$ ). Although the various values were tried for  $V_B$  on the computer setting looking for the fit to the experimental data, good agree-

TABLE III. Blood Levels of NAPA Conjugate ( $\bar{B}$ ) at Various Times after Intravenous Administration of NAPA (300 mg) to Rabbits

Rabbits	Time and blood levels of NAPA conjugate									
F	time (hr)	0.17	0.33	0.52	0.78	1.17	1.50	2.00	2.58	
	$\bar{B}$ (mg %)	2.11	6.27	10.50	9.97	8.84	4.65	2.60	1.26	
J	time (hr)	0.17	0.33	0.55	0.68	0.98	1.15	2.00	3.00	
	$\bar{B}$ (mg %)	3.78	6.96	5.29	6.13	3.74	3.20	1.75	0.53	
K	time (hr)	0.17	0.33	0.87	1.00	1.47	1.60	1.93	2.92	4.00
	$\bar{B}$ (mg %)	4.15	4.81	6.11	4.11	3.70	3.97	2.96	1.30	0.47
P	time (hr)	0.15	0.30	0.73	0.92	1.07	1.25	1.42	2.00	2.58
	$\bar{B}$ (mg %)	7.23	9.04	6.72	6.17	5.25	4.21	2.54	1.49	1.07
S	time (hr)	0.17	0.25	0.33	0.43	0.52	0.60	0.68	0.77	1.33
	$\bar{B}$ (mg %)	7.87	9.37	10.33	11.23	12.68	12.26	12.17	10.30	5.79
Z	time (hr)	1.75	2.00	3.00	4.00					
	$\bar{B}$ (mg %)	4.32	3.66	1.16	0.61					
Z	time (hr)	0.08	0.25	0.37	0.50	0.62	0.83	1.00	1.20	2.03
	$\bar{B}$ (mg %)	10.89	11.79	10.92	10.98	9.80	7.87	6.16	5.09	2.51
	time (hr)	2.50								
	$\bar{B}$ (mg %)	1.18								

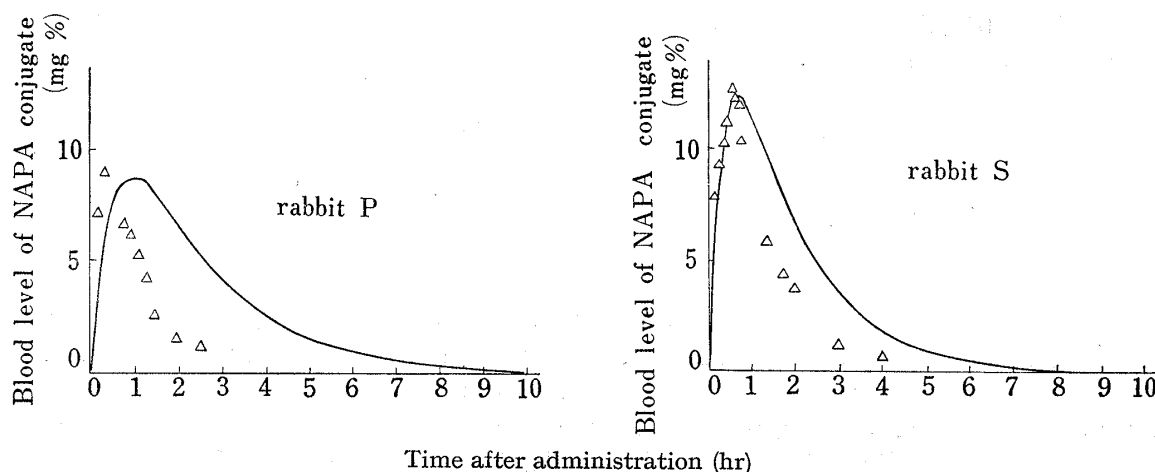

Fig. 3. Examples of Disagreement between Blood Levels of NAPA Conjugate Obtained Theoretically according to Model I and Those Observed Experimentally

Solid lines are theoretical values ( $V_B$ : 23.0 dl for rabbit P, 16.7 dl for rabbit S) and plotted points ( $\Delta$ ) are experimental values.

ment could not be found in all the rabbits including rabbit S which had alone shown a good agreement between the calculated and observed  $C_a$ . It became clear that whatever values are assigned to  $V_B$ , the calculated maxima of  $\bar{B}$  occur about 0.5 hour later than the experimental peaks and the slopes of the theoretical  $\bar{B}$  at the descending portions are much smoother than that of the experimental  $\bar{B}$  in all the rabbits. The examples of disagreements between the theoretical curves of  $\bar{B}$  obtained by an analog computer and the experimental  $\bar{B}$  are shown in Fig. 3. Thus, further evidence for inadequacy of Model I was obtained.

#### Approach to the Best Model Fitting to the Observed Data

Judging from the disagreements of the theoretical values according to Model I and the experimentally determined data relating to  $C_a$  and  $\bar{B}$  mentioned in the preceding sections, it was concluded that the NAPA conjugate in the blood would be eliminated more rapidly than expected by the rate constant  $k_b$ . Therefore, assuming one more compartment,  $B'$ ,<sup>13)</sup> for the NAPA conjugate between compartment B and C in Model I and employing an appropriate rate constant,  $K$ , greater than  $k_b$  to the transfer from B to  $B'$  (Model II), the theoretical values of  $\bar{B}$  were calculated by an analog computer to search the fit to the observed  $\bar{B}$  and the satisfactory result was obtained. While the new rate constant,  $K$ , being thus introduced, the process corresponding to  $k_b$  could not be ignored as its existence was verified by log "Sigma minus" plots. Then, if  $k_b$  were assigned to the transfer from  $B'$  to C, it would be a matter of course that the disagreeable tendencies of the theoretical and observed  $C_a$  indicated above become greater.

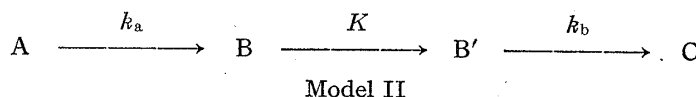

In order to improve the fitting of Model II to  $C_a$  keeping its good agreements relating to  $\bar{A}$  and  $\bar{B}$  intact, the direct process from B to C was added to Model II, which meant that the elimination process of  $\bar{B}$  became to consist of two competitive processes and  $K$  in Model II was divided into the two fractions;  $k_c$  and  $k_d$  for the process from B to  $B'$  and that from B

13) The compartment,  $B'$ , is quite hypothetical and introduced only for the convenience of kinetical interpretations. The discussion about its physiological meaning may be done later, if more informations become available.

to C, respectively (Model III). Consequently, good agreement between the theoretical and experimental  $C_a$  was obtained.

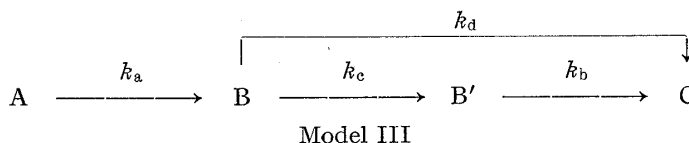

The calculation of the theoretical values of  $\bar{A}$ ,  $\bar{B}$ , and  $C_a$  according to Model III was carried out by means of an analog computer, the program of which is shown in Fig. 4. The procedure looking for the values of the parameters is as follows. At first, the previously determined values for  $A_0$  and  $k_a$  were set on the computer. Since it is necessary to estimate the volume of distribution of NAPA ( $V_A$ ) in order to obtain the theoretical curve of  $\bar{A}$  (*i.e.*

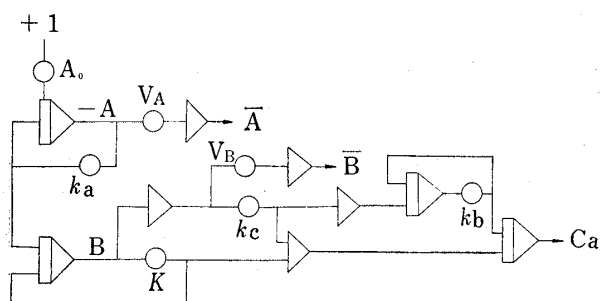

Fig. 4. Analog Computer Program and Differential Equations Corresponding to Model III

$$\begin{aligned} \frac{dA}{dt} &= -k_a A \\ \frac{dB}{dt} &= k_a A - KB \\ \frac{dB'}{dt} &= k_c B - k_b B' \\ \frac{dC}{dt} &= k_d B' + k_b B \end{aligned}$$

where  $K = k_c + k_d$ ,  $A = V_A \bar{A}$ ,  $B = V_B \bar{B}$

$\bar{A}$  = amounts of NAPA in compartment  $A/V_A$ ),  $V_A$  was estimated so as to fit well to the experimental  $\bar{A}$ . Then,  $K$  and  $V_B$  were estimated so that the theoretical curve of  $\bar{B}$  might trace the plots of the experimental  $\bar{B}$  as well as possible. Finally, after  $k_b$ , which was previously determined from the log "Sigma minus" plots, being set on the computer,  $K$  was divided to  $k_c$  and  $k_d$  so that the theoretical curve of  $C_a$  might give the best fitting to the experimental  $C_a$ . In this case, it was intended in the program that the sum of  $k_c$  and  $k_d$  was kept equal to  $K$  automatically.

The examples of good agreements of the theoretical curves according to Model III calculated by an analog computer and the experimentally observed data relating to  $\bar{A}$ ,  $\bar{B}$ , and  $C_a$  are shown in Fig. 5 and the values of the various parameters involved in Model III, which were determined by the graphical methods or an analog computer are listed in Table IV.

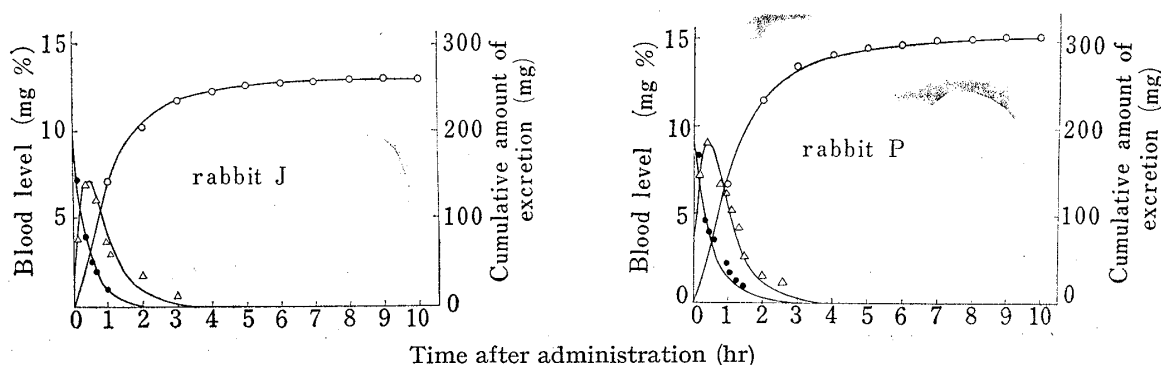

Fig. 5. Agreement between Theoretical Curves according to Model III drawn by an Analog Computer and Experimental Data following *i. v.* Administration of NAPA relating to  $\bar{A}$ ,  $\bar{B}$ , and  $C_a$

Solid lines are theoretical values and plotted points are experimental values; NAPA in blood (●), NAPA conjugate in blood (Δ), NAPA conjugate in urine (○).

TABLE IV. Rate and Other Constants on Interpreting NAPA Kinetics according to Model III determined by Graphical Methods and an Analog Computer

Rabbits	A <sub>0</sub> (mg) <sup>a)</sup>	k <sub>a</sub> (hr <sup>-1</sup> ) <sup>b)</sup>	k <sub>b</sub> (hr <sup>-1</sup> ) <sup>c)</sup>	K(hr <sup>-1</sup> ) <sup>d)</sup>	k <sub>c</sub> (hr <sup>-1</sup> )	k <sub>d</sub> (hr <sup>-1</sup> )	V <sub>A</sub> (dl)	V <sub>B</sub> (dl)
F	257.6	2.17	0.55	1.67	0.46	1.21	30.1	9.7
J	257.3	2.48	0.67	2.33	0.80	1.53	25.0	13.4
K	249.4	1.58	0.63	1.41	0.50	0.91	23.3	15.0
P	303.2	1.87	0.49	2.84	0.94	1.90	30.2	9.9
S	290.3	2.77	0.66	1.25	0.65	0.60	32.4	12.0
Z	275.4	3.15	0.63	1.83	0.39	1.44	31.4	10.6
Mean	272.2	2.34	0.61	1.89	0.62	1.27	28.7	11.8

- a) Recovered amounts up to 10 hr after administration, reproduced from Table II.
- b) Obtained from the slope of log A plots shown in Fig. 1.
- c) Obtained from the slope of log "Sigma minus" plots shown in Fig. 1.
- d) K is sum of k<sub>c</sub> and k<sub>d</sub>.

Furthermore, Model III was tested for its adequacy for the log "Sigma minus" plots. The theoretical "Sigma minus" according to Model III may be expressed:

$$A_0 - C_a = \frac{A_0(k_a k_d - K k_b)}{(k_a - K)(k_b - k_a)} e^{-k_a t} + \frac{A_0(k_a k_d - k_a k_b)}{(k_a - K)(K - k_b)} e^{-K t} - \frac{k_a k_c A_0}{(K - k_b)(k_b - k_a)} e^{-k_b t} \tag{6}$$

The right-hand side of equation (6) consists of three-term exponential expression, where k<sub>a</sub> and K are considerably greater than k<sub>b</sub> in the present case. When sufficient time has passed such that both the first and second terms become vanishingly small, equation (6) reduces to:

$$A_0 - C_a = \frac{-k_a k_c A_0}{(K - k_b)(k_b - k_a)} e^{-k_b t} \tag{7}$$

Logarithmic form of equation (7) is:

$$\log(A_0 - C_a) = \log \frac{-k_a k_c A_0}{(K - k_b)(k_b - k_a)} - \frac{k_b t}{2.303} \tag{8}$$

Equation (8) means that the theoretical curve of log "Sigma minus" becomes eventually linear giving the slope corresponding to k<sub>b</sub>, which is consistent with the log "Sigma minus" plots of the experimental data shown in Fig. 1.

The examples of the fitting of the log "Sigma minus" calculated by equation (6) with the parameter values given in Table IV to those derived from the experimental data are shown in Fig. 6. Good agreements are seen not only at the linear portions, but also at the earlier periods when the complicated curvatures are still remaining. This fact is another evidence for the validity of Model III.

To get more informations about the excretion of the NAPA conjugates, the authors

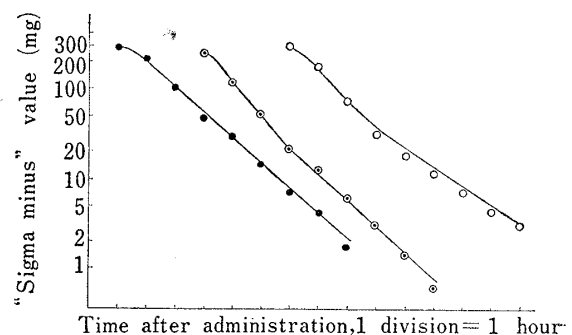

Fig. 6. Agreement between Theoretical log "Sigma minus" Curves according to Model III and log "Sigma minus" Plots obtained Experimentally

Solid curves are theoretical values and plotted points are experimental values; (O) for rabbit P, (⊙) for rabbit J, (●) for rabbit S. Each starting point corresponds to zero time.



studied on the experiments in which the glucuronide and the sulfate each was intravenously given to rabbits.<sup>14)</sup> The elimination processes of both the conjugates from the blood showed bi-exponential curves, which may be fitted by double compartmental model. The reason why Model III preparing no peripheral compartment for the conjugate formed in the body was chosen for describing the NAPA kinetics in the present studies are founded on a point of view that in model building one should start with the simplest model consistent with known information, as Berman<sup>15)</sup> also has pointed out and on the fact that all the experimentally obtained data in the present works were interpreted well with Model III. Further, both log "Sigma minus" plots derived from the urinary excretion data after the respective dosage of the conjugates gave eventually the linear portions with the similar slope which is roughly equal to that observed after administration of NAPA. Thus, it was confirmed that the excretion rates of the two conjugates are also not so large as assumed by Nelson and Morioka<sup>4a)</sup> when they are administered *per se*.

Though the present pharmacokinetic analysis is concerned only with rabbits, the data relating to  $\bar{A}$  and  $\bar{B}$  are well coincident with the observation reported by Brodie and Axelrod<sup>16)</sup> in man that the plasma levels of the NAPA conjugate were higher than those of free NAPA from 2 hours after oral administration of NAPA, which may be understood as a reasonable support for extrapolating the data on the NAPA kinetics described above from rabbits to man.

**Acknowledgement** This work was supported by the grand-in-aid of the Ministry of Education for which the authors wish to express their gratitude.

---

14) The details will be presented elsewhere.

15) M. Berman, *Ann. Internal. Med.*, **68**, 423 (1968).

16) B.B. Brodie and J. Axelrod, *J. Pharmacol. Exptl. Therap.*, **94**, 29 (1948).