

Studies on Encephalitogenic Fragments of Myelin Protein. I.¹⁾ Synthesis of Tryptophan-containing Fragments

KENJI SUZUKI, TAKASHI ABIKO, NOBUYOSHI ENDO, YUSUKE SASAKI²⁾
and JIRO ARISUE^{2a)}

*Tohoku College of Pharmacy*³⁾

(Received February 6, 1973)

Four peptides, H-Trp-Gly-Ala-Glu-Gly-Gln-Arg-OH, H-Ser-Trp-Gly-Ala-Glu-Gly-Gln-Arg-OH, H-Phe-Ser-Trp-Gly-Ala-Glu-Gly-Gln-Arg-OH and H-Arg-Phe-Ser-Trp-Gly-Ala-Glu-Gly-Gln-Arg-OH were synthesized by the classical method and tested for the induction of experimental allergic encephalomyelitis in guinea pigs. Consequently, it was found that the length limit of the peptide chain for the induction of the disease was the nonapeptide, H-Phe-Ser-Trp-Gly-Ala-Glu-Gly-Gln-Arg-OH.

The great interest in the basic protein of the myelin may be explained by its unique immunological property. As far as is known, it is the only brain protein which, when injected in complete Freund's adjuvant into experimental animals, results in a condition called experimental allergic encephalomyelitis (EAE).³⁾ This disease is characterized clinically by onset of weakness, ataxia and other neurological signs in two to three weeks after challenge and pathologically by multiple perivenular areas of demyelination and cellular infiltration. The significance of this condition is that it is considered as an experimental model for the human demyelinating disease, multiple sclerosis.⁴⁾ Recently, the amino acid sequences of the bovine⁵⁾ and human⁶⁾ basic proteins have been determined. This bovine protein has been shown to have at least four different sites capable of inducing EAE in rabbits.⁷⁾ Guinea pigs, on the other hand, respond to at least three different regions of the bovine⁸⁾ and human proteins.⁹⁾ Of these, N-terminal peptides of the human protein have been synthesized and shown to be encephalitogenic in guinea pigs.¹⁰⁾ Another region containing tryptophan residue has been characterized and synthesized by Eylar *et al.*¹¹⁾ It is a nonapeptide having amino acid sequence H-Phe-Ser-Trp-Gly-Ala-Glu-Gly-Gln-Lys-OH. Additional studies showed that three amino acid residues, Trp, Gln and Lys, in this sequence are essential for the encephalitogenic property of the peptide, although the Lys residue could be replaced by another amino acid residue, Arg.¹²⁾ Although, the sequence, H-Phe-Ser-Trp-Gly-Ala-Glu-Gly-

- 1) Symbols for amino acid derivatives and peptides used in this text are those recommended by IUPAC-IUB Commission on Biochemical Nomenclature; *Biochem. J.*, **126**, 773 (1972). Other abbreviations: OAo=acetoxime ester, DCC=dicyclohexylcarbodiimide, DMF=dimethylformamide.
- 2) Location: *Komatsushima, Sendai*; a) Present address: *Research Laboratory of Pollution, Sapporo*.
- 3) E.H. Eylar, J. Salk, G.C. Beveridge and L.V. Brown, *Arch. Biochem. Biophys.*, **132**, 34 (1969); See for review article, E.M. Shooter and E.R. Einstein, *Ann. Rev. Biochem.*, **40**, 635 (1971).
- 4) P.Y. Paterson, *Ann. Rev. Med.*, **20**, 75 (1969).
- 5) E.H. Eylar, S. Brostoff, G. Hashim, J. Caccam and P. Burnett, *J. Biol. Chem.*, **246**, 5770 (1971); E.H. Eylar, *Proc. Natl. Acad. Sci. U. S.*, **67**, 1425 (1970).
- 6) P.R. Carnegie, *Nature*, **229**, 25 (1971); *idem*, *Biochem. J.*, **123**, 57 (1971).
- 7) R. Shapira, F. C-H. Chou, S. McKneally, E. Urban and R.F. Kibler, *Science*, **173**, 736 (1971); E.H. Eylar, F.C. Westall and S. Brostoff, *J. Biol. Chem.*, **246**, 3418 (1971); H. Bergstrand and O. Berg, *Eur. J. Immunol.*, **1**, 499 (1972).
- 8) P.R. Burnett and E.H. Eylar, *J. Biol. Chem.*, **246**, 3425 (1971).
- 9) P.R. Carnegie, T.A. McPherson and G.S.M. Robson, *Immunology*, **19**, 55 (1970).
- 10) M.A. Barton, T.A. McPherson, R.U. Lemieux and G.O. Bain, *Can. J. Biochem.*, **50**, 689 (1972).
- 11) E.H. Eylar, J. Caccam, J. Jackson, F.C. Westall and A.B. Robinson, *Science*, **168**, 1220 (1970).
- 12) F.C. Westall, A.B. Robinson, J. Caccam, J. Jackson and E.H. Eylar, *Nature*, **229**, 22 (1971).

Gln-Arg-OH, of the human protein corresponding structurally to the Trp-containing fragment of the bovine protein has been suggested to be the determinant from the results of studies on synthetic peptides related mainly to the determinant of the bovine protein,¹²⁾ the details of experimental evidence have not been presented yet.

In the present communication, the synthesis of four analogs of the encephalitogenic fragment¹²⁾ of the human protein and the result of the biological assay of the synthetic peptides are described and on the basis of these findings the correlation of the structure and the encephalitogenic activity in guinea pigs is discussed. The classical method for the peptide synthesis is used in this investigation. The synthetic route for the heptapeptide, H-Trp-Gly-Ala-Glu-Gly-Gln-Arg-OH, is illustrated in Fig. 1. Z-Arg(NO₂)-ONb¹³⁾ was debenzoyloxycarbonylated with hydrogen bromide-acetic acid solution and the resulting H-Arg(NO₂)-ONb·HBr was condensed with Z-Gln-ONp¹⁴⁾ to form crystalline Z-Gln-Arg(NO₂)-ONb(I). After removal of the benzoyloxycarbonyl group of I, the resulting dipeptide ester was condensed with Z-Gly-ONp¹⁵⁾ to yield Z-Gly-Gln-Arg(NO₂)-ONb(II). After removal of the benzoyloxycarbonyl group of II, the resulting tripeptide ester was condensed with Boc-Glu(OBzl)-ONSu¹⁶⁾ to yield Boc-Glu(OBzl)-Gly-Gln-Arg(NO₂)-ONb(III). After removal of the *tert*-butyloxycarbonyl group of III with trifluoroacetic acid, the resulting tetrapeptide ester was condensed with Boc-Ala-ONSu¹⁷⁾ to yield Boc-Ala-Glu(OBzl)-Gly-Gln-Arg(NO₂)-ONb(IV). Z-Trp-Gly-OEt¹⁸⁾ was treated with hydrazine hydrate to yield Z-Trp-Gly-NHNH₂(V). After removal of the *tert*-butyloxycarbonyl group of IV, the resulting pentapeptide ester was condensed with the azide prepared from V according to Rudinger's procedure¹⁹⁾ to yield Z-Trp-Gly-Ala-Glu(OBzl)-Gly-Gln-Arg(NO₂)-ONb(VI). The fully protected heptapeptide(VI) was hydrogenated over 10% palladium-carbon in acetic acid solution overnight. The hydrogenated product was passed through carboxymethyl(CM-) cellulose column. Analysis of the main fraction by paper chromatography using Waley's solvent system²⁰⁾ revealed the presence of one major ninhydrin, Sakaguchi and Ehrlich positive spot and one minor spot. The crude heptapeptide was further purified through silica gel column chromatography developed with Waley's solvent system. The heptapeptide(VII) so obtained

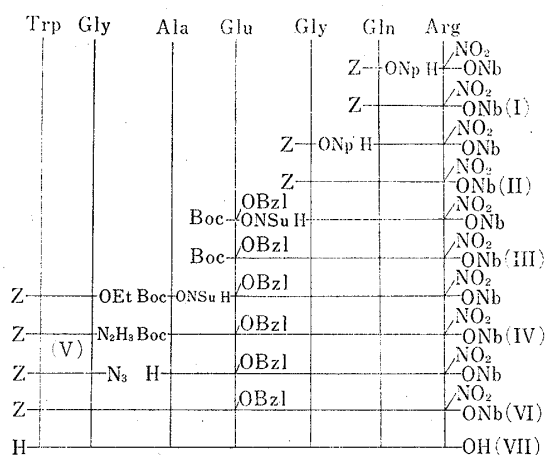

Fig. 1. Synthesis of H-Trp-Gly-Ala-Glu-Gly-Gln-Arg-OH(VII)

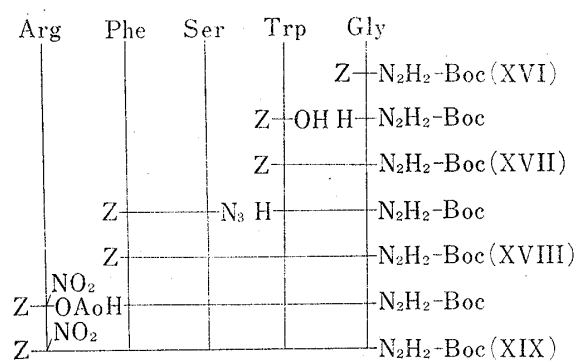

Fig. 2. Synthesis of Z-Arg(NO₂)-Phe-Ser-Trp-Gly-NHNH₂-Boc(XIX)

- 13) R.A. Boissonnas, St. Guttman and P.A. Jaquenoud, *Helv. Chim. Acta*, **43**, 1349 (1960).
- 14) M. Bodanszky and V. du Vigneaud, *J. Am. Chem. Soc.*, **81**, 5688 (1959).
- 15) B. Iselin, W. Rittel, P. Sieber and R. Schwyzer, *Helv. Chim. Acta*, **40**, 373 (1957).
- 16) P. Cuatrecasas, S. Fuchs and C.B. Anfinsen, *J. Biol. Chem.*, **242**, 1541 (1967).
- 17) G.W. Anderson, J.E. Zimmerman and F.M. Callahan, *J. Am. Chem. Soc.*, **86**, 1839 (1964).
- 18) N.C. Davis, *J. Biol. Chem.*, **223**, 935 (1956).
- 19) J. Honzl and J. Rudinger, *Collect. Czech. Chem. Commun.*, **26**, 2333 (1961).
- 20) S.G. Waley and G. Watson, *Biochem. J.*, **55**, 328 (1953).

was found to be a unity from the result of paper chromatography using two different solvent systems. The amino acid ratios in the acid hydrolysate of VII and aminopeptidase(AP)-M digest agreed with theoretical values. The minor spot described above was stained stable yellow on paper with Ehrlich reagent. This minor component is probably 2,3-dihydrotryptophan-containing peptide, because hydrogenation of tryptophan over palladium-carbon in acidic solution for 30 hr gave 2,3-dihydrotryptophan in good yield²¹⁾ and 2,3-dihydrotryptophan was stained stable yellow on paper with Ehrlich reagent. Further investigation for the identification of 2,3-dihydrotryptophan residue in our preparation has not been done. Hydrogenation for longer period of any of tryptophan-containing peptides prepared in this study gave an yellow stained component with Ehrlich reagent on paper chromatogram. To avoid this side reaction, de-blocking procedure by liquid hydrogen fluoride²²⁾ was used in the later stages of the present synthetic work, except for the preparation of H-Phe-Ser-Trp-Gly-Ala-Glu-Gly-Gln-Arg-OH(XV) which has been done almost concurrently with that of VII. Further, *p*-nitrobenzyl ester group which is un-removable by the hydrogen fluoride procedure,²²⁾ was removed by catalytic hydrogenation for shorter period.²³⁾

For the synthesis of H-Ser-Trp-Gly-Ala-Glu-Gly-Gln-Arg-OH(XI) the following series of reactions was carried out. Z-Trp-Gly-OEt was hydrogenated and the resulting H-Trp-Gly-OEt was condensed with Z-Ser-OAo.²⁴⁾ The resulting protected tripeptide(VIII) was converted to the hydrazide Z-Ser-Trp-Gly-NHNH₂(IX). Routine coupling of the azide of IX and the de-*tert*-butyloxycarbonylated IV yielded Z-Ser-Trp-Gly-Ala-Glu-(OBzl)-Gly-Gln-Arg(NO₂)-ONb(X). X was treated with liquid hydrogen fluoride and then hydrogenated for 5 hr to yield H-Ser-Trp-Gly-Ala-Glu-Gly-Gln-Arg-OH(XI).

For the synthesis of H-Phe-Ser-Trp-Gly-Ala-Glu-Gly-Gln-Arg-OH(XV), the following series of reactions was carried out. Coupling of the de-benzyloxycarbonylated VIII and Z-Phe-ONp²⁵⁾ yielded the fully protected tetrapeptide(XII). Coupling of the azide

TABLE I. Encephalitogenic Activity of Synthetic Peptides

Material	Dose (μg)	Encephalitogenic activity ^{a)}
H-Trp-Gly-Ala-Glu-Gly-Gln-Arg-OH(VII)	5	0/6
	20	0/5
	100	0/5
H-Ser-Trp-Gly-Ala-Glu-Gly-Gln-Arg-OH(XI)	29	0/5
	100	0/5
	H-Phe-Ser-Trp-Gly-Ala-Glu-Gly-Gln-Arg-OH(XV)	5
20		4/5
100		3/5
H-Arg-Phe-Ser-Trp-Gly-Ala-Glu-Gly-Gln-Arg-OH(XXI)	5	2/2
	100	4/5
	Bovine encephalitogenic protein	20

a) Encephalitogenic activity is expressed as the number of guinea pigs showing clinical signs over the number of animals tested in the manner as described by Eylar.⁹⁾ The appearance of clinical signs of EAE occurred in about two weeks after injection of the decapeptide(XXI). In the case of the nonapeptide(XV), the signs were observed later than this period.

- 21) J.W. Daly, A.B. Mauger, O. Yonemitsu, V.K. Antonov, K. Takase and B. Witkop, *Biochemistry*, **6**, 648 (1967).
- 22) S. Sakakibara, Y. Shimonishi, Y. Kishida, M. Okada and H. Sugihara, *Bull. Chem. Soc. Japan*, **40**, 2164 (1967); See for review article, S. Sakakibara, "Chemistry and Biochemistry of Amino Acids, Peptides and Proteins," Vol. 1, ed. by B. Weinstein, Marcel Dekker, Inc., New York, N. Y., 1971, p. 51.
- 23) H. Schwarz and K. Arakawa, *J. Am. Chem. Soc.*, **81**, 5691 (1959).
- 24) M. Fujino and O. Nishimura, *Chem. Pharm. Bull. (Tokyo)*, **17**, 1937 (1969).
- 25) M. Bodanszky and V. du Vigneaud, *J. Am. Chem. Soc.*, **81**, 6072 (1959).

of the tetrapeptide hydrazide(XIII) derived from XII and the de-*tert*-butyloxycarbonylated IV yielded Z-Phe-Ser-Trp-Gly-Ala-Glu(OBzl)-Gly-Gln-Arg(NO₂)-ONb(XIV). Catalytic hydrogenation and the purification gave homogenous nonapeptide(XV).

For the synthesis of H-Arg-Phe-Ser-Trp-Gly-Ala-Glu-Gly-Gln-Arg-OH(XXI), the following series of reactions was carried out. Z-Gly-OH²⁶⁾ was condensed with *tert*-butyl-carbazate by N,N'-dicyclohexylcarbodiimide to yield Z-Gly-NHNH-Boc(XVI) in crystalline. As illustrated in Fig. 2, elongation of the chain with Z-Trp-OH,²⁷⁾ Z-Phe-Ser-NHNH₂¹³⁾ and Z-Arg(NO₂)-OAc²²⁾ yielded Z-Trp-Gly-NHNH-Boc(XVII), Z-Phe-Ser-Trp-Gly-NH-NH-Boc(XVIII) and Z-Arg(NO₂)-Phe-Ser-Trp-Gly-NHNH-Boc(XIX), respectively. Coupling of the protected pentapeptide azide derived from XIX and de-*tert*-butyloxycarbonylated IV yielded Z-Arg(NO₂)-Phe-Ser-Trp-Gly-Ala-Glu(OBzl)-Gly-Gln-Arg(NO₂)-ONb(XX). Deblockings of XX in the same manner as described for the preparation of the octapeptide(XI) yielded the desired H-Arg-Phe-Ser-Trp-Gly-Ala-Glu-Gly-Gln-Arg-OH(XXI). The overall yield was 5% based on the starting material Z-Arg(NO₂)-ONb.

The encephalitogenic activity of the four synthetic peptides, assayed by the procedure given by Eylar, *et al.*,³⁾ is shown in Table I.²⁸⁾ The heptapeptide(VII) and octapeptide(XI) were inactive and the nonapeptide(XV) and decapeptide(XXI) were active almost in the same degree. The above mentioned results, together with the fact that H-Phe-Ser-Trp-Gly-Ala-Glu-Gly-Gln-OH is inactive in guinea pigs,¹¹⁾ strongly suggest that the length limit of the peptide chain for the induction of EAE in guinea pigs is the nonapeptide(XV). Eylar²⁹⁾ has recently speculated, from the results of their studies,^{11,12)} that essential requirement for the disease induction is the sequence H-Trp-Gly-Ala-Glu-Gly-Gln-Arg-OH. However, the author's conclusion does not support the speculation.

Experimental

All melting points are uncorrected. Peroxide free dioxane and ether used for the treatment of Trp-containing compounds were stored over Al₂O₃ powder. Unless otherwise mentioned, Z-group of the protected amino acids and peptides were deblocked with HBr in AcOH or catalytic hydrogenation in the presence of AcOH and Boc-group with trifluoroacetic acid and the resulting amino components were chromatographed on filter paper, Toyo Roshi No. 51, at room temperature. *Rf*¹ values refer to Partridge system³⁰⁾ and *Rf*² values refer to the system of BuOH-pyridine-AcOH-H₂O (30:20:6:24).²⁰⁾ The amino acid composition of the acid hydrolysates and aminopeptidase-M digests³¹⁾ were determined with Hitachi Model KLA-3B amino acid analyzer according to the directions given by Moore, *et al.*³²⁾

Z-Gln-Arg(NO₂)-ONb(I)—Z-Arg(NO₂)-ONb (2.5 g) was dissolved in 2.8N HBr in AcOH (20 ml). After 40 min at room temperature, dry ether was added to the reaction mixture. The precipitate thereby formed was collected and dried over KOH pellets in vacuum. To a solution of this product in DMF (20 ml), Z-Gln-ONp (2.2 g) was added, followed by Et₃N to keep the solution slightly alkaline. After 24 hr at room temperature, the reaction mixture was diluted with 1N NH₄OH (3 ml) with stirring. After 1 hr, the mixture was poured into cold 1N NH₄OH with stirring. To the suspension, 50% NH₄OAc was added dropwise with stirring to form precipitate. The precipitate was collected and washed successively with 1N NH₄OH, H₂O, 1N HCl and H₂O. The dried product was washed with hot EtOAc; needles, yield 2.8 g (88%); mp 193°; $[\alpha]_D^{25}$ -13.1° (*c*=1.6, DMF); de-Z peptide ester HBr salt, *Rf*¹ 0.43, *Rf*² 0.77, single ninhydrin positive spot; *Anal.* Calcd. for C₂₆H₃₂O₁₀N₃: C, 50.64; H, 5.23; N, 18.18. Found: C, 50.23; H, 5.33; N, 18.06.

26) M. Bergmann and L. Zervas, *Ber.*, **65**, 1192 (1932).

27) E.L. Smith, *J. Biol. Chem.*, **175**, 39 (1948).

28) The biological assay was performed by Drs. Y. Nagai and S. Otani, *et al.* of the Institute of Medical Science, University of Tokyo by whom the details of the assay will be published elsewhere.

29) E.H. Eylar, "Immunological Disorders of the Nervous System," ed. by L. Röwland, Academic Press, New York, 1971, p. 50.

30) S.M. Partridge, *Biochem. J.*, **42**, 238 (1948).

31) G. Pfeleiderer and P.G. Celliers, *Biochem. Z.*, **339**, 186 (1963); G. Pfeleiderer and P.G. Celliers, M. Stanulovic, E.D. Washmuth, H. Determan and G. Braunitzer, *ibid.*, **340**, 552 (1964). Röhm and Haas (Darmstadt) preparation was used.

32) S. Moore, D.H. Spackman and W.H. Stein, *Anal. Chem.*, **30**, 1185 (1958).

Z-Gly-Gln-Arg(NO₂)-ONb (II)—The compound was prepared from I (2.0 g) and Z-Gly-ONp (1.1 g) essentially in the same manner as described above. To the reaction mixture, EtOAc was added and the EtOAc solution was washed successively with 1N NH₄OH, H₂O, 1N HCl and H₂O. The solution was dried over MgSO₄ and concentrated to small volume and petroleum ether was added to the residue. The precipitate thereby formed was washed with cold EtOAc; amorphous powder, yield 1.2 g (55%); mp 103—110°; $[\alpha]_D^{18} - 26.9^\circ$ ($c=1.3$, DMF); de-Z peptide ester HBr salt, Rf^1 0.26, Rf^2 0.59, single ninhydrin positive spot; *Anal.* Calcd. for C₂₈H₃₅O₁₁N₉·H₂O: C, 48.62; H, 5.39; N, 18.23. Found: C, 48.85; H, 5.43; N, 18.27.

Boc-Glu(OBzl)-Gly-Gln-Arg(NO₂)-ONb (III)—The compound was prepared from II (1.1 g) and Boc-Glu(OBzl)-ONSu (0.8 g) essentially in the same manner as described above. To the reaction mixture, EtOAc was added and the EtOAc solution was washed with 1N citric acid and H₂O. The solution was dried over MgSO₄ and concentrated to a small volume. Petroleum ether was added to the residue and the precipitate thereby formed was washed with cold EtOAc; amorphous powder, yield 0.8 g (59%); mp 118—120°; $[\alpha]_D^{18} + 15.0^\circ$ ($c=2.2$, DMF); Rf^1 0.64, Rf^2 0.89, single ninhydrin positive spot; *Anal.* Calcd. for C₃₇H₅₀O₁₄N₁₀·H₂O: C, 50.68; H, 5.98; N, 15.98. Found: C, 50.73; H, 5.89; N, 15.39.

Boc-Ala-Glu(OBzl)-Gly-Gln-Arg(NO₂)-ONb (IV)—III (1.1 g) was dissolved in trifluoroacetic acid (5 ml) and the solution was kept at room temperature for 30 min, when dry ether was added. The resulting tripeptide ester was condensed with Boc-Ala-ONSu (0.4 g) essentially in the same manner as described in the preparation of III. The product was recrystallized from EtOH; amorphous powder, yield 0.8 g (76%); mp 140—145°; $[\alpha]_D^{18} + 7.5^\circ$ ($c=0.7$, DMF); Rf^1 0.63, Rf^2 0.88, single ninhydrin positive spot; *Anal.* Calcd. for C₄₆H₅₅O₁₅N₁₁: C, 51.66; H, 5.96; N, 16.57. Found: C, 51.66; H, 5.98; N, 16.08.

Z-Trp-Gly-NHNH₂ (V)—Z-Trp-Gly-OEt (1.7 g) was dissolved in MeOH (50 ml). To this solution, hydrazine hydrate (0.63 ml) was added and the solution was kept on standing at room temperature for 24 hr. After evaporation of MeOH, the residue was recrystallized from MeOH and peroxide free ether; amorphous powder, yield 0.88 g (55%); mp 139—141°; $[\alpha]_D^{18} - 35.6^\circ$ ($c=1.0$, DMF); *Anal.* Calcd. for C₂₁H₂₃O₄N₅: C, 64.03; H, 5.63; N, 14.21. Found: C, 64.24; H, 5.72; N, 14.34.

Z-Trp-Gly-Ala-Glu(OBzl)-Gly-Gln-Arg(NO₂)-ONb (VI)—A solution of V (82 mg) in DMF (3 ml) was chilled in dry ice-80% EtOH bath to -60°. To this solution, 4N HCl in dioxane (0.5 ml) was added, followed by iso-amyl nitrite (0.034 ml). The mixture was stirred for 20 min until hydrazine test was negative. The mixture was neutralized with Et₃N (0.28 ml) at -60°. IV (186 mg) was treated with trifluoroacetic acid (2 ml) as described above. The resulting pentapeptide ester trifluoroacetate in DMF (5 ml) was neutralized with Et₃N and chilled in an ice bath. To a cold solution of the peptide ester, a cold solution of the dipeptide azide described above was added and stirred at 5° for 48 hr and at room temperature for 1 hr. The mixture was poured into cold 1N NaHCO₃. To the suspension thereby formed, 50% NH₄OAc was added dropwise with stirring to form precipitate. The precipitate was collected and washed successively with 1N NaHCO₃, H₂O, 1N citric acid and H₂O. Dried product was recrystallized from EtOH; amorphous powder, yield 207 mg (85%); mp 118—126°; $[\alpha]_D^{18} - 30.5^\circ$ ($c=0.4$, DMF); de-Z peptide ester HBr salt, Rf^1 0.93, Rf^2 0.96, single ninhydrin positive spot; *Anal.* Calcd. for C₅₆H₆₆O₁₇N₁₄·1/2H₂O: C, 55.30; H, 5.55; N, 16.12. Found: C, 55.02; H, 5.46; N, 15.82.

H-Trp-Gly-Ala-Glu-Gly-Gln-Arg-OH (VII)—The fully protected heptapeptide VI (72 mg) was hydrogenated in 50% AcOH (12 ml) over 5% Pd-C for 24 hr. The catalyst was removed by the aid of Cellite. The solution was evaporated to dryness and the residue was dried over KOH pellets in vacuum. The solution of the crude product in H₂O (10 ml) was added to a CM-cellulose column (2.0 × 18.0 cm) which was eluted with a linear gradient elution from H₂O (300 ml) in mixing chamber to 0.075M pyridinium acetate (pH 5.1, 300 ml) in reservoir. Fractions of 13 ml each were collected at a flow rate of 4 ml/min with an automatic fraction collector. The arginine-containing peptide was located in the eluate by Sakaguchi reaction. The eluates in tubes No. 30 to 34 containing the heptapeptide were pooled, evaporated to dryness in vacuum and lyophilized. Analysis by paper chromatography revealed the presence of two ninhydrin, Sakaguchi and Ehrlich positive spots with Rf^1 0.10 (major), 0.20 (minor) and Rf^2 0.16 (minor), 0.28 (major). The minor spot was stained stable yellow with Ehrlich reagent. A solution of the crude product in Waley's solvent (5 ml) was added to a column (2 × 28 cm) made by mixing silicic acid (25 g) and Cellite (10 g) which was eluted with the same solvent system. Fractions of 5 ml each were collected at a flow rate 5 ml/50 min and the peptide was located in the eluate showing positive Sakaguchi and Ehrlich reaction. The eluates in tubes No. 15 to 20 containing the heptapeptide were pooled, evaporated to dryness and lyophilized; yield 44 mg (75%); mp 162—173°; $[\alpha]_D^{18} - 19.4^\circ$ ($c=0.7$, H₂O); Rf^1 0.11, Rf^2 0.29, single ninhydrin, Sakaguchi and Ehrlich positive spot; amino acid ratios in the acid hydrolysate: Ala 1.0, Glu 2.4, Gly 1.9, Arg 0.8; amino acid ratios in the AP-M digest; Trp 1.3, Ala 1.1, Glu 0.7, Gly 1.9, Gln 0.8, Arg 1.0.

Z-Ser-Trp-Gly-OEt (VIII)—Z-Trp-Gly-OEt (2.0 g) in MeOH (20 ml) and 1N AcOH (5 ml) was hydrogenated in the presence of 5% Pd-C in the usual manner until the evolution of CO₂ ceased. The catalyst was removed by filtration and the filtrate was evaporated in vacuum. To a solution of this dipeptide ester in dioxane (14 ml), Z-Ser-OAo (1.5 g) and AcOH (0.07 ml) was added. After 24 hr, the reaction mixture was diluted with EtOAc and the solution was washed successively with 1N NH₄OH, H₂O, 1N HCl and H₂O. The solution was dried over MgSO₄ and evaporated in vacuum. The residue was recrystallized from EtOAc; amorphous powder, yield 1.1 g (45%); mp 148—150°; $[\alpha]_D^{18} - 33.3^\circ$ ($c=1.0$, DMF); de-Z peptide ester acetate,

Rf^1 0.60, Rf^2 0.84, single ninhydrin positive spot; *Anal.* Calcd. for $C_{26}H_{30}O_7N_4$: C, 61.16; H, 5.92; N, 10.98. Found: C, 61.03; H, 5.81; N, 10.81.

Z-Ser-Trp-Gly-NHNH₂ (IX)—The compound was prepared from VIII (500 mg) and hydrazine hydrate (0.3 ml) essentially in the same manner as described in the preparation of V. The precipitate thereby formed was collected on filter and washed successively with MeOH and ether. It was recrystallized from MeOH and ether; amorphous powder, yield 367 mg (75%); mp 151—156°; $[\alpha]_D^{18}$ -26.9° ($c=1.3$, DMF); *Anal.* Calcd. for $C_{24}H_{28}O_6N_6 \cdot 1/2H_2O$: C, 57.94; H, 5.91; N, 16.89. Found: C, 57.58; H, 6.38; N, 16.78.

Z-Ser-Trp-Gly-Ala-Glu(OBzl)-Gly-Gln-Arg(NO₂)-ONb (X)—The compound was prepared from IX (118 mg) and IV (151 mg) essentially in the same manner as described in the preparation of VI. The dried product was washed successively with hot EtOAc and EtOH; amorphous powder, yield 159 mg (74%); mp 136—144°; $[\alpha]_D^{18}$ -15.2° ($c=0.7$, DMF); de-Z peptide ester HBr salt, Rf^1 0.60, Rf^2 0.93, single ninhydrin positive spot; *Anal.* Calcd. for $C_{59}H_{71}O_{19}N_{15} \cdot 2H_2O$: C, 53.27; H, 5.68; N, 15.79. Found: C, 53.71; H, 5.44; N, 15.30.

H-Ser-Trp-Gly-Ala-Glu-Gly-Gln-Arg-OH (XI)—X (100 mg) was placed in an HF-reaction cylinder together with anisole (1 ml). HF (5 ml) was added into the cylinder using an HF-reaction apparatus and the mixture was allowed to react at 0° for 30 min. The residue was diluted with H₂O (10 ml) and the solution was washed with EtOAc three times. The clear solution thus obtained was passed through a column of Dowex 1 × 2 (acetate form, 2 × 6 cm). The column was washed with H₂O and the Sakaguchi positive eluates were collected together in a receiver. The solution was lyophilized. The crude product in 1N AcOH (10 ml) was hydrogenated for 5 hr in the usual manner and the solvent was evaporated in vacuum. The solution of the crude product in H₂O (10 ml) was added to a CM-cellulose column (2 × 18 cm) which was eluted with a linear gradient elution from H₂O (300 ml) in mixing chamber to 0.05M NH₄OAc buffer (pH 6.50, 300 ml) in reservoir. Fractions of 13 ml each were collected at a flow rate of 4 ml/min with an automatic fraction collector and the absorbancy of each fraction was determined at 280 mμ. The eluates in tubes No. 34 to 38 containing the octapeptide were pooled, evaporated to dryness in vacuum and lyophilized. NH₄OAc was removed by repeated lyophilization to constant weight; colorless fluffy material, yield 20 mg (26%); mp 152—168°; $[\alpha]_D^{18}$ -15.3° ($c=0.5$, H₂O); Rf^1 0.15, Rf^2 0.30, single ninhydrin, Sakaguchi and Ehrlich positive spot; amino acid ratios in the acid hydrolysate: Ser 0.8, Gly 1.8, Ala 0.9, Glu 1.6, Arg 0.8; amino acid ratios in the AP-M digest; Ser 1.0, Trp 1.2, Gly 2.1, Ala 1.2, Glu 0.8, Gln 0.7, Arg 0.7.

Z-Phe-Ser-Trp-Gly-OEt (XII)—VIII (2.6 g) in MeOH (80 ml) and 1N AcOH (5.5 ml) was hydrogenated in the usual manner for 5 hr. The resulting tripeptide ester was condensed with Z-Phe-ONp (2.3 g) essentially in the same manner as described in the preparation of 1. The reaction mixture was diluted with EtOAc and washed successively with 1N NH₄OH, H₂O, 1N HCl and H₂O. EtOAc solution was dried over MgSO₄ and evaporated to dryness. The residue was recrystallized from EtOH and H₂O; amorphous powder, yield 2.4 g (69%); mp 157—159°; $[\alpha]_D^{18}$ $+30.1^\circ$ ($c=1.1$, DMF); de-Z peptide ester acetate, Rf^1 0.71, Rf^2 0.91, single ninhydrin positive spot; *Anal.* Calcd. for $C_{35}H_{39}O_8N_5$: C, 63.91; H, 5.98; N, 10.65. Found: C, 63.36; H, 5.90; N, 10.34.

Z-Phe-Ser-Trp-Gly-NHNH₂ (XIII)—The compound was prepared from XII (346 mg) and hydrazine hydrate (0.1 ml) essentially in the same manner as described in the preparation of V. The products was recrystallized from EtOH; amorphous powder, yield 277 mg (82%); mp 203—206°; $[\alpha]_D^{18}$ $+25.5^\circ$ ($c=0.5$, DMF); *Anal.* Calcd. for $C_{33}H_{37}O_7N_7 \cdot 1/2H_2O$: C, 60.72; H, 5.87; N, 15.02. Found: C, 60.80; H, 5.87; N, 14.41.

Z-Phe-Ser-Trp-Gly-Ala-Glu(OBzl)-Gly-Gln-Arg(NO₂)-ONb (XIV)—The compound was prepared from IV (161 mg) and XIII (160 mg) essentially in the same manner as described in the preparation of VI. The crude product in DMF was poured into cold 1N HCl with stirring. The precipitate thereby formed was washed successively with 1N HCl, H₂O, 1N NaHCO₃ and H₂O. The dried product was recrystallized from EtOH; amorphous powder, yield 141 mg (57%); mp 165—175°; $[\alpha]_D^{18}$ -14.0° ($c=1.0$, AcOH); de-Z peptide ester HBr salt, Rf^1 0.69, Rf^2 0.88, single ninhydrin positive spot; *Anal.* Calcd. for $C_{68}H_{76}O_{20}N_{16} \cdot 2H_2O$: C, 55.44; H, 5.48; N, 15.21. Found: C, 55.62; H, 5.55; N, 14.83.

H-Phe-Ser-Trp-Gly-Ala-Glu-Gly-Gln-Arg-OH (XV)—XIV (60 mg) in 50% AcOH was hydrogenated in the usual manner for 24 hr. The hydrogenated product in H₂O (10 ml) was added to a CM-cellulose column (2 × 7 cm) which was eluted with a linear gradient elution from H₂O (300 ml) in mixing chamber to 0.05M NH₄OAc buffer (pH 6.50, 300 ml) in reservoir. Fractions of 13 ml each were collected at a flow rate of 4 ml/min with an automatic fraction collector and the absorbancy of each fraction was determined at 280 mμ. The eluates in tubes No. 22 to 25 containing the nonapeptide were pooled, evaporated to dryness in vacuum and lyophilized. NH₄OAc was removed by repeated lyophilization to constant weight; colorless fluffy material, yield 19 mg (39%); mp 147—156°; $[\alpha]_D^{18}$ -47.2° ($c=0.3$, H₂O); Rf^1 0.16, Rf^2 0.36, single ninhydrin, Sakaguchi and Ehrlich positive spot; amino acid ratios in the acid hydrolysate: Phe 0.9, Ser 1.0, Gly 2.3, Ala 0.9, Glu 2.1, Arg 0.7; amino acid ratios in the AP-M digest: Phe 1.2, Ser 0.9, Gly 1.9, Ala 1.2, Glu 1.3, Gln 0.6, Trp 1.0.

Z-Gly-NHNH-Boc (XVI)—To a cold solution of Z-Gly-OH (2.09 g) in EtOAc (100 ml) Boc-NHNH₂ (2.09 g) was added, followed by DCC (2.06 g). After 1 hr at 0° and 2 hr at room temperature, a few drops of AcOH was added. Dicyclohexylurea thereby formed was removed by filtration and the filtrate was washed

successively with 1N NaHCO₃, H₂O, 1N citric acid and H₂O. The EtOAc solution was dried over MgSO₄ and evaporated to dryness. The resulting oily residue was recrystallized from EtOAc and petroleum ether. The crystallization was induced by seeding of the crystals; amorphous powder, yield 2.87 g (89%); mp 81—82°; de-Z derivative, *Rf*¹ 0.47, *Rf*² 0.70, single ninhydrin positive spot; *Anal.* Calcd. for C₁₅H₂₁O₅N₃: C, 55.72; H, 6.55; N, 13.00. Found: C, 56.01; H, 6.65; N, 13.06.

Z-Trp-Gly-NHNH-Boc (XVII)—XVI (6.5 g) in MeOH was hydrogenated in the usual manner as described in the preparation of VIII. The hydrogenated product in DMF (70 ml) was condensed with Z-Trp-OH (6.1 g) by DCC (4.1 g) as described above. The product was recrystallized from EtOAc and petroleum ether; amorphous powder, yield 6.1 g (60%); mp 105—115°; de-Z derivative, *Rf*¹ 0.70, *Rf*² 0.94, single ninhydrin and Ehrlich positive spot. This compound was used for the preparation of XVIII without further purification.

Z-Phe-Ser-Trp-Gly-NHNH-Boc (XVIII)—The compound was prepared from Z-Phe-Ser-NHNH₂ (0.6 g) and H-Trp-Gly-NHNH-Boc derived from XVII (0.6 g) by catalytic hydrogenation essentially in the same manner as described in the preparation of VI. The reaction mixture was diluted with EtOAc and the organic layer was washed successively with 1N NaHCO₃, H₂O, 1N citric acid and H₂O. The EtOAc solution was dried over MgSO₄ and evaporated to dryness. The residue was recrystallized from EtOAc and petroleum ether; amorphous powder, yield 0.50 g (56%); mp 125—134°; $[\alpha]_D^{25} + 3.8^\circ$ (*c*=1.3, DMF); de-Z derivative, *Rf*¹ 0.73, *Rf*² 0.92, single ninhydrin positive spot; *Anal.* Calcd. for C₃₅H₄₅O₉N₇·2H₂O: C, 58.54; H, 6.33; N, 12.57. Found: C, 58.94; H, 6.34; N, 12.14.

Z-Arg(NO₂)-Phe-Ser-Trp-Gly-NHNH-Boc (XIX)—XVIII (3.73 g) was de-benzyloxycarbonylated as described above. To a solution of the resulting H-Phe-Ser-Trp-Gly-NHNH-Boc in DMF (50 ml), Z-Arg(NO₂)-OAc (2.04 g) and AcOH (0.44 ml) was added. After 3 days, the reaction mixture was diluted with EtOAc and the solution was washed successively with 1N NH₄OH, H₂O, 1N citric acid and H₂O. A small amount of MeOH was added to prevent precipitation of the product during the washing. The EtOAc solution was kept in a freezer. The precipitate thereby formed was recrystallized from MeOH and H₂O; amorphous powder, yield 3.4 g (72%); mp 128—137°; $[\alpha]_D^{25} - 12.3^\circ$ (*c*=1.3, DMF); the fully protected peptide, *Rf*¹ 0.81, *Rf*² 0.89, single Ehrlich positive spot; *Anal.* Calcd. for C₄₄H₅₆O₁₂N₁₂·H₂O: C, 54.87; H, 6.07; N, 17.45. Found: C, 54.81; H, 6.18; N, 17.18.

Z-Arg(NO₂)-Phe-Ser-Trp-Gly-Ala-Glu(OBzl)-Gly-Gln-Arg(NO₂)-ONb (XX)—XIX (400 mg) was dissolved in trifluoroacetic acid (1 ml) and kept at room temperature for 25 min. The solvent was evaporated in vacuum and the residue was dried over KOH pellets in vacuum. Z-Arg(NO₂)-Phe-Ser-Trp-Gly-NHNH₂ thus obtained was condensed with IV (390 mg) essentially in the same manner as described in the preparation of VI. The reaction mixture was poured into 1N citric acid with stirring. To the suspension thereby formed, 50% NH₄OAc was added dropwise with stirring to form precipitate. The precipitate was washed as usual way and dried over P₂O₅ in vacuum. The product was washed with EtOAc and recrystallized from EtOH; amorphous powder, yield 148 mg (41%); mp 152—158°; $[\alpha]_D^{25} - 10.0^\circ$ (*c*=1.0, DMF); the fully protected peptide, *Rf*¹ 0.88, *Rf*² 0.94, single Ehrlich positive spot; *Anal.* Calcd. for C₇₄H₉₁O₂₃N₂₁: C, 54.10; H, 5.58; N, 17.91. Found: C, 54.56; H, 5.32; N, 17.42.

H-Arg-Phe-Ser-Trp-Gly-Ala-Glu-Gly-Gln-Arg-OH (XXI)—The decapeptide was prepared from XX (82 mg) essentially in a similar manner as described in the preparation of XI. XX was treated with HF first and then hydrogenated for 5 hr in 1N AcOH. CM-cellulose column chromatography (2×10 cm) was carried out by using a linear gradient elution from H₂O (300 ml) in mixing chamber to 0.1M NH₄OAc buffer (pH 6.50, 300 ml) in reservoir. The eluates in tubes No. 35 to 43 containing the decapeptide were pooled and treated as usual way; yield 39.7 mg (59%); mp 196—211° (decomp.); $[\alpha]_D^{25} - 16.4^\circ$ (*c*=2.0, H₂O); *Rf*¹ 0.15, *Rf*² 0.35, single ninhydrin, Sakaguchi and Ehrlich positive spot; amino acid ratios in the acid hydrolysate: Phe 1.1, Ser 0.9, Gly 2.1, Ala 1.0, Glu 2.0, Arg 1.9, amino acid ratios in the AP-M digest: Phe 1.1, Ser 1.0, Trp 0.8, Gly 2.1, Ala 1.1, Glu 1.0, Gln 0.8, Arg 2.2.

Acknowledgement The authors thank Miss K. Kudo for amino acid analysis and the staffs of Central Analysis Laboratory, Department of Chemistry, University of Tohoku, for elemental analysis.