

# CHEMICAL & PHARMACEUTICAL BULLETIN

Vol. 22, No. 9

September 1974

---

## Regular Articles

---

{Chem. Pharm. Bull.}  
{22(9)1955—1962(1974)}

UDC 547.466.1.05

### Isolation of a Hypocalcemic Substance in Bovine Parotid Gland, and Some Properties of this Substance<sup>1)</sup>

AKIRA MIZUTANI, TOYOHIRO KITAMURA, NAOKI YAMADA, HITOSHI INABA,  
YUKIO NAITO, and TAKAHARU MIZUTANI

*Faculty of Pharmaceutical Sciences, Nagoya City University<sup>2)</sup>*

(Received April 28, 1973)

The main hypocalcemic protein from bovine parotid gland was purified by chromatography on DEAE-cellulose, gel chromatography on Sepharose 6B, preparative polyacrylamide gel electrophoresis, and second gel chromatography on Sepharose 6B, resulting in a single substance by analytical disc electrophoresis, gel chromatography, and isoelectric focusing. This purified protein lowered the serum calcium concentration by  $10.83 \pm 1.01\%$  in a dose of 0.008 mg/kg in rabbits. Amino acid analysis of this protein revealed its relatively acidic nature. Its molecular weight was found to be 48000 by sodium dodecyl sulfate-polyacrylamide gel electrophoresis.

Bovine parotid gland has been shown to contain biological active materials which lower serum calcium levels in rabbits.<sup>3,4)</sup> Partial purification of the hypocalcemic materials was achieved by fractional precipitation with  $(\text{NH}_4)_2\text{SO}_4$ , and the fraction thus obtained was found to be of high purity by Tiselius electrophoresis and ultracentrifugation.<sup>5,6)</sup> The time course action of the partially purified fraction was shown to be different from that induced by thyrocalcitonin, and its effect was reported to be neither a consequence of the stimulated secretion of thyrocalcitonin nor that of the suppressed secretion of parathyroid hormone.<sup>7)</sup> However, we found by polyacrylamide gel disc electrophoresis that the fraction was still a mixture of several protein species. Therefore, further purification is desirable and remains to be accomplished. The present paper reports the methods for complete purification and some biochemical properties of the hypocalcemic substance.

#### Materials and Methods

All the fractionation procedures were carried out in a cold room at about 5° or under ice cooling, and toluene was added to the buffer solutions as a preservative.

- 
- 1) Presented at the 92nd Annual Meeting of Pharmaceutical Society of Japan, Osaka, April 1972.
  - 2) Location: *Tanabe-dori, Mizuho-ku, Nagoya, 467, Japan.*
  - 3) A. Ogata, Y. Ito, and A. Mizutani, *Yakugaku Zasshi*, **64**, 325 (1944).
  - 4) Y. Ito and A. Mizutani, *Yakugaku Zasshi*, **72**, 244 (1952).
  - 5) Y. Ito and A. Mizutani, *Yakugaku Zasshi*, **72**, 1499 (1952).
  - 6) Y. Ito, Y. Kubota, and Y. Shibuya, *J. Biochem. (Tokyo)*, **47**, 422 (1960).
  - 7) E. Ogata, H. Suzuki, E. Shimazawa, K. Nakanowatari, and H. Asano, *Endocrinol. Japan*, **18**, 235 (1971).

**Materials**—Acetone-dried powder was prepared from fresh bovine parotid gland by the method of Ogata, *et al.*<sup>3)</sup> Yield of the powder was about 1.6% of the gland. The extract from the powder with physiological saline was fractionated with  $(\text{NH}_4)_2\text{SO}_4$  by the method of Ito and Mizutani,<sup>4)</sup> and a fraction precipitated at 7–15% of  $(\text{NH}_4)_2\text{SO}_4$  concentration (7–15%  $(\text{NH}_4)_2\text{SO}_4$  fraction) was obtained in a yield of about 5% from the acetone-dried powder.

**Chromatography on DEAE-Cellulose**—DEAE-cellulose (Tohoku Pulp Product; exchange capacity, 0.97 mEq/g), activated by the conventional method,<sup>8)</sup> was fully equilibrated with 0.05M phosphate buffer (pH 7.38, 0.13  $\mu$ ) to be used initially and packed into a chromatographic column. The 7–15%  $(\text{NH}_4)_2\text{SO}_4$  fraction was dissolved in the initial buffer at a concentration of 40 mg/ml, and loaded on a column. Elution was carried out with stepwise increase of NaCl concentrations from 0 to 0.15, 0.27, and 0.47M in 0.05M phosphate buffer (pH 7.38, 0.13  $\mu$ ). The eluted fractions were dialyzed against deionized water and lyophilized. A part of the fraction was concentrated with Amicon ultrafiltration cell (UM-10 filter), dialyzed, and lyophilized.

**Gel Chromatography on Sepharose 6B**—Sepharose 6B (Pharmacia Fine Chemicals) was equilibrated with 0.05M phosphate buffer (pH 7.38, 0.13  $\mu$ ) and packed in columns. A fraction purified by DEAE-cellulose chromatography (600–800 mg) was dissolved in the buffer solution to give a concentration of 40 mg/ml, centrifuged at  $10000 \times g$  to remove insoluble materials, and the supernatant was loaded on a  $5 \times 100$  cm column. Elution was performed by the ascending method, at a water pressure of 30–40 cm and a flow rate of 2 ml/cm<sup>2</sup>/hr.

**Preparative Polyacrylamide Gel Electrophoresis**—This was carried out essentially by a modification of the method for analytical disc electrophoresis of Davis.<sup>9)</sup> One hundred milliliters of 7.5% acrylamide solution (pH 8.9) was placed in a glass tube ( $5.0 \times 60$  cm) fitted with a rubber stopper at its bottom, and

water was layered on the solution to effect polymerization. On the polymerized 7.5% gel, 20 ml of 3.75% acrylamide–0.625% N,N'-Methylenebisacrylamide solution (pH 6.7) was placed and photopolymerized. Then the rubber stopper was removed and the gel was supported with a sintered glass filter or a hard porous synthetic resin plate as shown in Fig. 1a. This glass tube containing the gel was attached to a hard vinyl tube filled with Tris-glycine buffer (pH 8.6, 0.05  $\mu$ ), with a precaution not to trap air bubbles. A glass tube was attached to the other outlet of the hard vinyl tube and both the glass tubes were filled with the same Tris-glycine buffer. A fraction obtained by gel chromatography (60–80 mg) was dissolved in 5 ml of Tris-HCl buffer (pH 8.9, 0.05  $\mu$ ), thoroughly mixed with 2 ml of 40% sucrose solution, and gently layered on the gel using a constant flow pump. Electrophoresis was carried out in a cold room at a constant voltage of 400 V and 10–30 mA for about 40 hr. After completion of electrophoresis, the buffer solution in the glass tube was syphoned off and the gel was taken out. In order to find the positions of migrated proteins inside the gel, one side of the gel was cut off in about 2 mm thickness and 2 cm width. This gel specimen was stained with Amido black 10B for 1 min and destained with 7% AcOH. By this means, the positions of the protein bands inside the gel specimen will become apparent after about 1 hr. This staining must be made as soon as

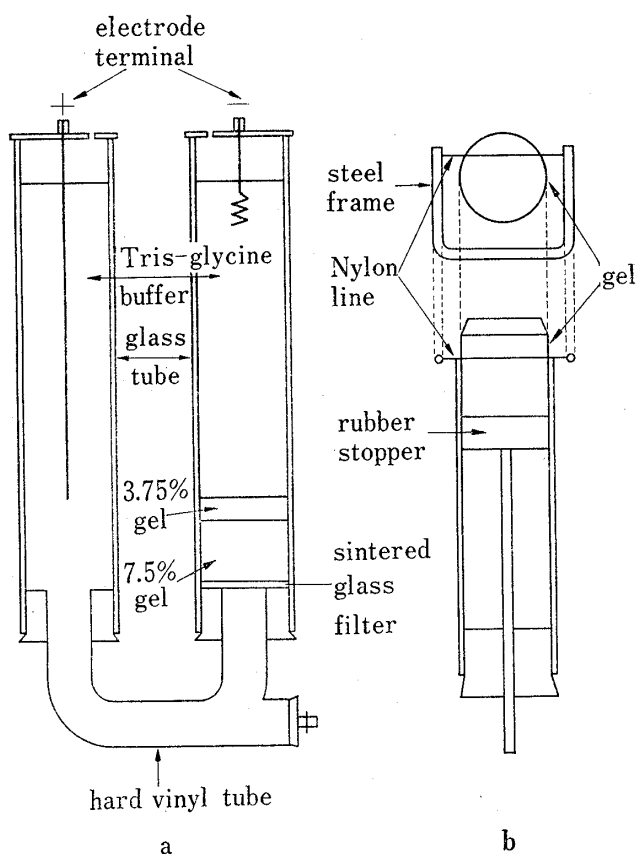

Fig. 1. Schematic Representation of Preparative Disc Electrophoretic Apparatus (a) and Gel Slicing Apparatus (b)

possible in order to minimize diffusion of the proteins inside the original gel. The original gel was then sliced in about 1 mm thickness, using the stained gel specimen as a reference, with the apparatus shown in Fig. 1b. Each of these slices was triturated with quartz sand and then extracted with 10 ml of

8) E.A. Peterson and H.A. Sober, *J. Am. Chem. Soc.*, **78**, 751 (1956).

9) B.J. Davis, *Ann. N. Y. Acad. Sci.*, **121**, 404 (1964).

Tris-HCl buffer (pH 8.6, 0.05  $\mu$ ) for several hours. The mixture were then centrifuged at  $10000 \times g$  to remove the quartz sand and gel pieces, and the supernatants were dialyzed and lyophilized. Purity of the fractions was examined by analytical disc electrophoresis. Fractions giving a single band and having an identical relative mobility were pooled, and passed through a Sepharose 6B column to remove contaminating fine gel particles.

**Bioassay**—Bioassay of the hypocalcemic activity was carried out as described previously.<sup>10)</sup> The significance of the difference between test and control groups was tested by the aid of the *t*-table. The results were considered as effective when the difference was significant at the level of 0.05 or 0.01 probability. Pyrogen test was carried out according to that given in the Japanese Pharmacopoeia Ed. 8.<sup>11)</sup>

**Polyacrylamide Gel Disc Electrophoresis for Analysis and Isoelectric Focusing**—In order to examine the homogeneity of the protein fractions, analytical polyacrylamide gel disc electrophoresis, staining, and destaining were carried out by the method of Davis.<sup>9)</sup> The resulting gels were submitted to recording by an autodensitometer, Fuji-Riken Model FD-A-IV. Isoelectric focusing was carried out with 0.5% Ampholine in the ranges of pH 5—7 according to the method of Vesterberg and Svensson.<sup>12)</sup>

**Molecular Weight Determination by Sodium Dodecyl Sulfate-Polyacrylamide Gel Electrophoresis**—Electrophoresis by the split gel method of Dunker and Rueckert<sup>13)</sup> was carried out in 10% polyacrylamide gel containing 0.1% sodium dodecyl sulfate to measure the mobility. The molecular weight of the purified material was calculated by comparing its mobility with those of a set of proteins (Schwarz-Mann product) of known molecular weight. Gel staining followed the method of Weber and Osborn.<sup>14)</sup> A part of the protein sample solution was submitted to electrophoresis without preincubation with mercaptoethanol.

**Amino Acid Analysis**—The purified material was hydrolyzed at  $110^\circ \pm 2^\circ$  with 6N HCl and the dried hydrolyzate was submitted to analysis by the Hitachi Model KLA-3B amino acid analyzer.<sup>15)</sup> Values obtained from the hydrolyzates for 24, 36, and 48 hr were corrected by extrapolation to 0 hr and the amounts of amino acids were determined. The amount of tryptophan was determined by the method of Spies and Chambers.<sup>16)</sup>

**Determination of Sugar and Protein**—The sugar content was determined by the phenol- $H_2SO_4$  method.<sup>17)</sup> Protein concentrations in sample solutions were estimated by measuring optical density of the solutions at 280 nm, or by the method of Lowry, *et al.*<sup>18)</sup> using bovine serum albumin as a standard.

## Results

### Chromatography on DEAE-Cellulose

Fig. 2 shows the result of chromatography of the 7—15%  $(NH_4)_2SO_4$  fraction obtained from the extracts of bovine parotid gland on DEAE-cellulose. Table I gives the hypocalcemic activity and yield of the samples shown in Fig. 2. Fraction D-III has the most potent activity among the four fractions in Fig. 2. The hypocalcemic activity shows a dose-response relationship to a certain extent as shown in Table I. Fraction D-III was used for subsequent steps of purification.

### Gel Chromatography on Sepharose 6B

The result of gel chromatography of fraction D-III on Sepharose 6B is shown in Fig. 3. Although fraction G-I was not hypocalcemic, fraction G-II eluted at  $K_{av}$  0.3 had a hypocalcemic activity and its yield was 46%, as shown in Table II.

### Preparative Polyacrylamide Gel Electrophoresis

Fig. 4 shows further separation of fraction G-II by preparative gel electrophoresis. The original gel was sliced in about 1 mm thickness as shown in Fig. 4 and the stained patterns of

- 10) A. Mizutani, K. Yamamoto, H. Sato, Y. Saito, H. Kitsugawa, and H. Yamamoto, *Yakugaku Zasshi*, **91**, 297 (1971).
- 11) Pharmacopoeia Japonicae Editio VIII, Part I, Explanatory Notes," Hirokawa Shoten, Tokyo, 1971, B-160.
- 12) O. Vesterberg and H. Svensson, *Acta Chem. Scand.*, **20**, 820 (1966).
- 13) A.K. Dunker and R.R. Rueckert, *J. Biol. Chem.*, **244**, 5074 (1969).
- 14) K. Weber and M. Osborn, *J. Biol. Chem.*, **244**, 4406 (1969).
- 15) D.H. Spackman, W.H. Stein, and S. Moore, *Anal. Chem.*, **30**, 1190 (1958).
- 16) J.R. Spies and D.C. Chambers, *Anal. Chem.*, **21**, 1249 (1949).
- 17) M. Dubois, K.A. Gilles, J.K. Hamilton, P.A. Reber, and F. Smith, *Anal. Chem.*, **28**, 350 (1956).
- 18) O.H. Lowry, N.J. Rosebrough, A.L. Farr, and R.J. Randall, *J. Biol. Chem.*, **193**, 265 (1951).

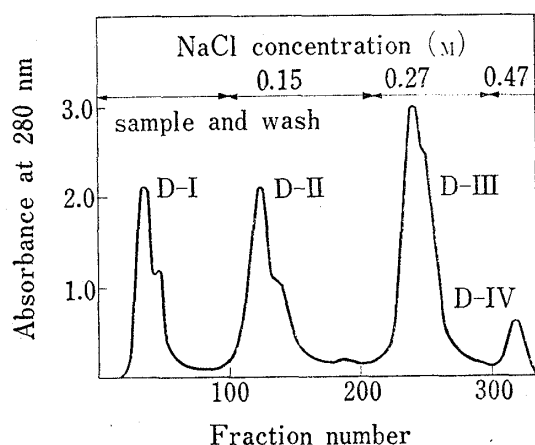

Fig. 2. Elution Pattern of 7—15%  $(\text{NH}_4)_2\text{SO}_4$  Fraction in Chromatography on DEAE-cellulose

stepwise elution with 0.05M phosphate buffer (pH 7.38, 0.13  $\mu$ ) containing 0.15, 0.27, and 0.47M NaCl. sample, 7.80 g; column, 0.4 $\times$ 114 cm; fraction volume, 30 ml

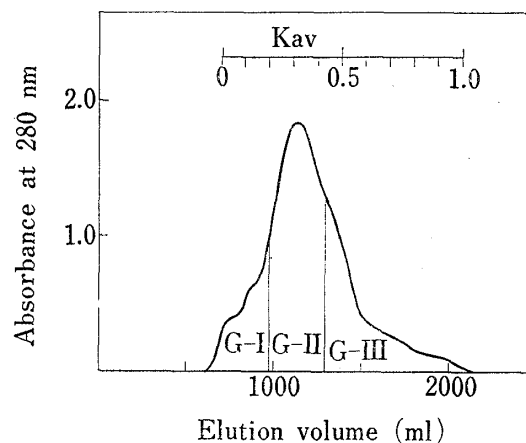

Fig. 3. Elution Pattern of Fraction D-III in Gel Chromatography on Sepharose 6B

Sample (670 mg) was dissolved in 20 ml of 0.05M phosphate buffer (pH 7.38, 0.13  $\mu$ ). column, 5.0 $\times$ 103 cm; void volume, 760 ml; total volume, 2020 ml

TABLE I. Yield and Hypocalcemic Activity of Each Fraction obtained from Chromatography on DEAE-cellulose

Fraction	Yield		Dose (mg/kg)	Mean $\pm$ S.E. ( $n=6$ ) Percent decrease of serum calcium
	(mg)	(%)		
7—15% $(\text{NH}_4)_2\text{SO}_4$ fraction	7800	100	1.0	10.20 $\pm$ 1.15 <sup>a)</sup>
D-I	1870	24.0	0.5	4.63 $\pm$ 0.75 <sup>b)</sup>
D-II	2067	26.5	0.5	6.90 $\pm$ 1.89 <sup>b)</sup>
D-III	1801	23.1	0.5	12.75 $\pm$ 1.32 <sup>a)</sup>
D-IV	665	8.4	0.5	10.39 $\pm$ 1.06 <sup>a)</sup>

a) significantly different from control ( $p < 0.01$ )

b)  $p > 0.05$

TABLE II. Yield and Hypocalcemic Activity of the Fractions obtained from Gel Filtration on Sepharose 6B

Fraction	Yield		Dose (mg/kg)	Mean $\pm$ S.E. ( $n=6$ ) Percent decrease of serum calcium
	(mg)	(%)		
D-III (starting material of G-I—III)	670	100	—	—
G-I	90	13	0.25	1.68 $\pm$ 0.56 <sup>a)</sup>
G-II	306	46	0.25	9.61 $\pm$ 1.25 <sup>b)</sup>
G-III	229	34	0.25	6.95 $\pm$ 1.48 <sup>a)</sup>
E-I·S-II <sup>c)</sup>	11	18	0.01	4.71 $\pm$ 1.11 <sup>a)</sup>
E-II-III·S-II <sup>c)</sup>	29	48	0.01	10.24 $\pm$ 1.06 <sup>b)</sup>
E-IV·S-II <sup>c)</sup>	7	12	0.01	6.87 $\pm$ 0.76 <sup>b)</sup>
D-III EG <sup>d)</sup>	—	—	0.008	10.83 $\pm$ 1.01 <sup>b)</sup>

a)  $p > 0.05$

b) significantly different from control ( $p < 0.01$ )

c) starting material (G-II) 60 mg

d) Purified by gel chromatography of the fraction, obtained by preparative disc electrophoresis of fraction D-III.

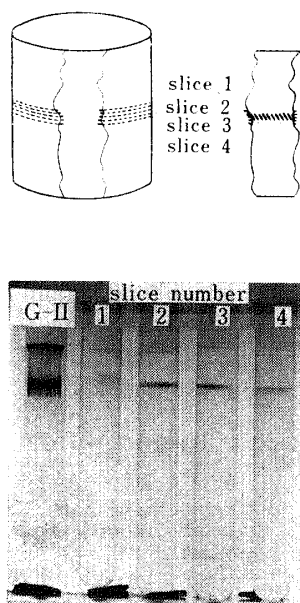

Fig. 4. Schematic Representation of Gel Slicing and Comparison of Electropherograms of Extracts of Gel Slices obtained from Preparative Electrophoresis of Fraction G-II

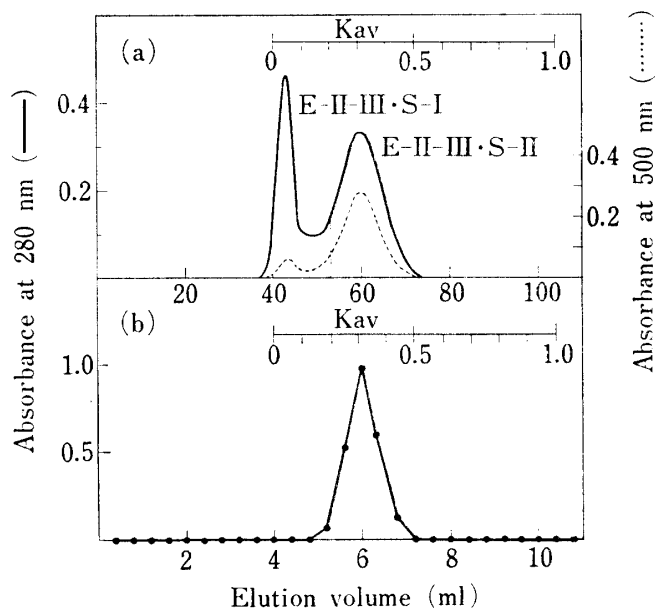

Fig. 5. Elution Pattern of E-II-III in Gel Chromatography on Sepharose 6B

(a) Fraction E-II-III (60 mg), obtained from preparative disc electrophoresis, was dissolved in 2 ml of 0.05M phosphate buffer (pH 7.38) and chromatographed on a column (1.4×86) cm of Sepharose 6B by the ascending method.

(b) Fraction E-II-III·S-II in (a) was dissolved in 0.1 ml of the same phosphate buffer and chromatographed on a column (0.78×24.4 cm) of Sepharose 6B by the descending method.

analytical polyacrylamide gels of the fractions obtained from preparative electrophoresis are shown in Fig. 4. The stained patterns of slices 2 (E-II) and 3 (E-III) show a sharp band and these fractions were pooled (E-II-III), whereas those of slices 1 (E-I) and 4 (E-IV) show a broad band and two bands, respectively. Bioassay of these fractions was carried out after separation of fine gel particles by second gel chromatography.

### Second Gel Chromatography on Sepharose 6B

Fig. 5a shows the result of the second gel chromatography of fraction E-II-III on Sepharose 6B. Fraction E-II-III·S-II eluted at Kav 0.3 gave a single band in analytical gel electrophoresis (Fig. 6), and showed a high hypocalcemic activity (Table II). The other peak (E-II-III·S-I) eluted after a void volume was probably due to fine polyacrylamide gel particles contaminating E-II-III. Fractions E-I and IV were also purified by second gel chromatography and the patterns were similar to that in Fig. 5a. The protein fractions were designated as E-I·S-II and E-IV·S-II, respectively. Hypocalcemic activities of E-I·S-II, E-II-III·S-II, and E-IV·S-II are shown in Table II. The fraction E-II-III·S-II was obtained in a yield of 48% of the amount of G-II applied on the preparative gel. In order to check the purity of fraction E-II-III·S-II shown in Fig. 5a, gel chromatography on Sepharose 6B was carried out and its result is shown in Fig. 5b. The peak of fraction E-II-III·S-II showed a good symmetry supporting its homogeneity. For further examination of its homogeneity, the sample was submitted to isoelectric focusing and its result is shown in Fig. 7. Fraction E-II-III·S-II presented a single peak with isoelectric point of pH 5.3. Table II gives the yield at each purification step and the hypocalcemic activity of the proteins. Approximately equal hypocalcemic activity was observed even reducing the dose of samples after each purification step, and the final purified product (E-II-III·S-II) reduced the calcium level by  $10.24 \pm 1.06\%$  in a dose of 0.01 mg/kg. The purified sample (D-III EG; Table II) obtained by preparative electrophoresis of D-III followed by gel chromatography was also effective by reducing

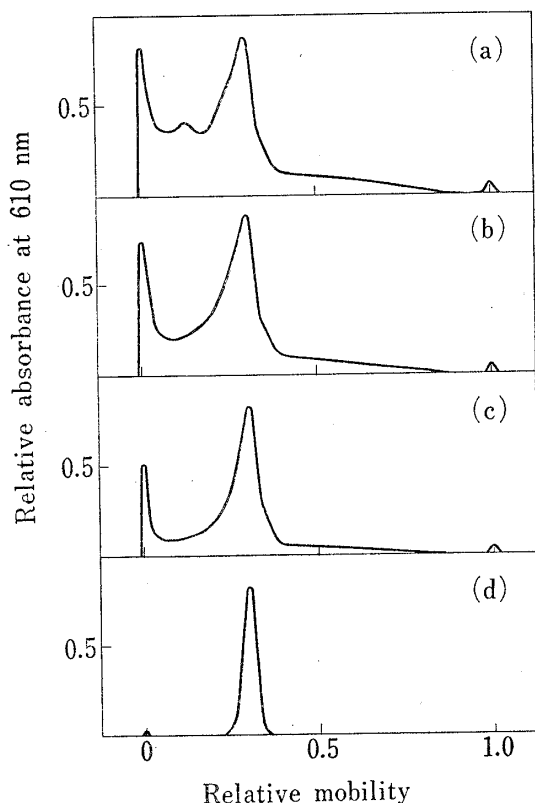

Fig. 6. Densitometric Tracing of Stained Gels

sample; (a) 7–15%  $(\text{NH}_4)_2\text{SO}_4$  fraction (b) fraction D-III in Fig. 2, (c) fraction G-II in Fig. 3, (d) fraction E-II-III-S-II in Fig. 5a

### Amino Acid Analysis

Table III shows the result of amino acid analysis of fraction E-II-III-S-II. Amino acid composition of the protein shows large amounts of aspartic acid, glutamic acid, and leucine,

TABLE III. Amino Acid Composition

Amino acid	$\mu\text{moles/mg}$ of protein	Moles/mole of protein <sup>a)</sup>
Lysine	0.53	25.6
Histidine	0.08	3.9
Arginine	0.52	25.1
Aspartic acid	1.02	48.8
Threonine	0.40	19.2
Serine	0.43	20.8
Glutamic acid	1.38	66.2
Proline	0.07	3.4
Glycine	0.50	24.2
Alanine	0.79	37.9
Cystine	0.03	1.4
Valine	0.41	19.6
Methionine	0.15	7.3
Isoleucine	0.46	22.0
Leucine	1.00	48.1
Tyrosine	0.18	8.4
Phenylalanine	0.17	8.1
Tryptophan <sup>b)</sup>	0.11	5.1

a) calculated from the molecular weight of 48000.

b) estimated by the method of Spies and Chambers<sup>16)</sup>

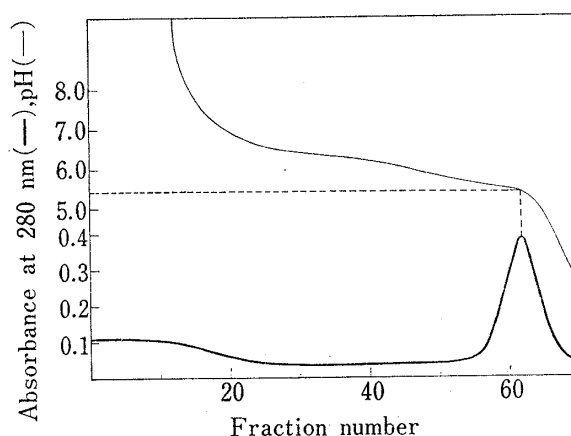

Fig. 7. Isoelectric Focusing of Fraction E-II-III-S-II

Sample (3.1 mg) was dissolved in 4.6 ml of 0.5% ampholine (pH 5–7) and electrophocused for 24 hr at 900 V. Fractions of 2 ml were collected.

the calcium concentration by  $10.83 \pm 1.01\%$  in a dose of 0.008 mg/kg. In order to examine the contamination of pyrogenic substances throughout the purification steps, pyrogen test was carried out on the sample (D-III EG), but a dose of 0.02 mg/kg failed to show any pyrogenic activity. Densitometric tracings of the electrophoretic patterns of the samples at each purification step are shown in Fig. 6.

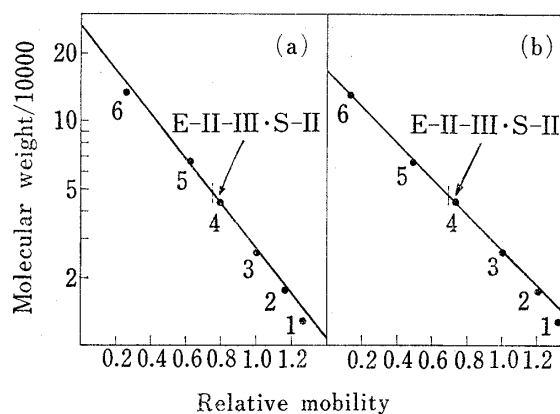

Fig. 8. Molecular Weight Determination of Fraction E-II-III-S-II by SDS-Polyacrylamide Gel Electrophoresis

(a) without preincubation with 2-mercaptoethanol

(b) after incubation with 2-mercaptoethanol

1: cytochrome *c*, 2: myoglobin, 3: chymotrypsinogen A, 4: ovalbumin, 5: bovine serum albumin, 6: bovine serum albumin (dimer)

and small amounts of cystine, histidine, and tryptophan, as in other proteins. The characteristic feature is a comparatively small amount of proline.

### Molecular Weight Determination by Sodium Dodecyl Sulfate-Polyacrylamide Gel Electrophoresis

Fig. 8 shows relative mobilities in sodium dodecyl sulfate-10% polyacrylamide gel electrophoresis of known proteins and fraction E-II-III·S-II obtained from bovine parotid gland on the abscissa, when the mobility of chymotrypsinogen A is taken as 1, and the logarithm of the molecular weight of the protein on the ordinate. The sample shown in Fig. 8a was not treated with mercaptoethanol before electrophoresis. Fraction E-II-III·S-II has an apparently smaller mobility, though slight, than that of ovalbumin and its molecular weight was calculated as 48000. Fig. 8b shows the results with the sample treated with mercaptoethanol before electrophoresis and its molecular weight was approximately 47000 and there was almost no difference before and after reduction with mercaptoethanol.

### Determination of Sugar

The sugar in fraction E-II-III·S-II was determined by the phenol- $\text{H}_2\text{SO}_4$  method and the content was 0.50% as calculated from a calibration curve based on glucose.

### Discussion

The 7—15%  $(\text{NH}_4)_2\text{SO}_4$  fraction reported previously<sup>4)</sup> was still a mixture of several protein species. Further purification was attempted by chromatography on DEAE-cellulose and gel chromatography on Sepharose 6B, and inactive or poorly active materials were excluded. However, the contaminants appearing before and after the main band in analytical polyacrylamide gel electrophoresis were not removed. For this reason, preparative polyacrylamide gel electrophoresis was carried out with a commercial apparatus but well-reproducible results were not obtained. The present method gives a good separation but the recovery is somewhat poor because of the presence of a step of extraction from the gel. This procedure is also defective in that fine polyacrylamide gel particles become mixed in the protein solution, but they can be removed by gel chromatography. The apparatus can easily be constructed from commercial glass tubes. The suitable amount of the sample is 50—100 mg, and a larger amount than that gives poor separation. Electrophoresis was carried out with the apparatus in a cold room without special cooling but there was no marked heat evolution inside the gel. When the electric current was 40 mA and voltage was 800 V, the gel became slightly warm. Fraction E-II-III·S-II was found to be a single protein by analytical disc electrophoresis, gel chromatography on Sepharose 6B, and isoelectric focusing, and its homogeneity was also confirmed from the results of sodium dodecyl sulfate-polyacrylamide gel electrophoresis.

While dose-response relationship of the hypocalcemic substances from parotid gland has been described by Ogata and Ito,<sup>19)</sup> the effect is not distinctly quantitative but qualitative. The assay used by us is rather qualitative, and similar to that used by Kubota, *et al.* for separation of a Parotin-like substance.<sup>20)</sup> Nonetheless, approximately equal hypocalcemic activity was observed by reducing the dose after each purification step as shown in Table II. The hypocalcemic substance might be purified by approximately 100-fold of the starting materials (7—15%  $(\text{NH}_4)_2\text{SO}_4$  fraction) from the specific activity but this cannot be concluded easily because of the qualitative nature of the assay. The yield of the hypocalcemic activity could not be calculated either for the same reason.

The molecular weight of the purified hypocalcemic protein was 48000 as estimated by sodium dodecyl sulfate-polyacrylamide gel electrophoresis and differs considerably from that of 132000 calculated from the sedimentation constant and the diffusion constant by Ito, *et al.*<sup>6)</sup>

19) A. Ogata and Y. Ito, *Yakugaku Zasshi*, **64**, 332 (1944).

20) K. Kubota, H. Ueki, H. Shoji, and S. Shoji, *Yakugaku Zasshi*, **92**, 796 (1972).

However, the sample used by Ito, *et al.* was obtained by ammonium sulfate fractionation, and probably contained some impurities, as indicated in Fig. 6a, so that no definite comparison can be made. Its molecular weight in aqueous solution is 132000 and there remains a possibility that the protein consists of subunits of 48000. There is necessity for measuring the molecular weight of the purified protein in aqueous solution, *per se*, by physicochemical methods such as ultracentrifugation.

There was no marked characteristics in amino acid composition of fraction E-II-III·S-II except for its relatively acidic nature but it seems necessary to determine the quantities of glutamine, asparagine, and cystine by other methods.

The determination of sugar content in the purified sample by the phenol-sulfuric acid method gave results approximately agreeing with those obtained with the ammonium sulfate-fractionated sample by Mizutani.<sup>21)</sup> The phenol-sulfuric acid method allows determination of hexose, its oligosaccharides, and its methylated sugars, and is considered to be less affected by proteins, but coloration varies with sugars. The present result showing sugar content of 0.5% was obtained from the standard curve using glucose and it is still unknown what kind of sugar is present. It would be necessary also to carry out the qualitative and quantitative determination of other kinds of sugars (uronic acid, deoxysugars, hexosamine, sialic acid, *etc.*), and to examine the contents of lipids and phosphoric acid.

**Acknowledgement** The authors are grateful to Dr. Hideo Goto of the analysis center of this University for amino acid analysis and to Teikoku Hormone Mfg. Company for the supply of some of the crude materials used in this study.

21) A. Mizutani, *Yakugaku Zasshi*, 72, 1511 (1952).