

Prediction of Plasma Protein Binding of Salicylic Acid in the Rabbit¹⁾

YOSHIHARU KANEO, ATSUKO NISHIKAWA, and YURIKO KATO

Faculty of Pharmaceutical Sciences, Science University of Tokyo²⁾

(Received December 16, 1978)

The binding of salicylic acid to rabbit plasma protein *in vitro* and *in vivo* was examined using the semi-microultrafiltration method developed by Imamura *et al.* This method is suitable for the determination of intact binding of drugs *in vivo* since the plasma sample need not be diluted and the volume of filtrate is so small that the drug-protein equilibrium may not be affected. The binding parameters of salicylic acid to rabbit serum determined *in vitro* were: $n=1.77$ and $k=2.53 \times 10^4 \text{ M}^{-1}$, where n and k are the maximal number of binding sites and the binding constant, respectively. The percentages of salicylic acid bound *in vivo* following oral administration of sodium salicylate to rabbits were in fair agreement with the theoretical values estimated using the binding parameters described above. It appears that the plasma protein binding of salicylic acid *in vivo* is predictable from data obtained *in vitro* in rabbits.

Keywords—salicylic acid; plasma protein binding; plasma concentration; semi-microultrafiltration method; equilibrium dialysis method; Langmuir's adsorption isotherm

A number of investigations have demonstrated that protein binding of drugs can affect their distribution, metabolism, excretion, and pharmacological effect. The binding of drugs to plasma protein may be influenced by many factors such as protein concentration, pH, endogenous substances, physiological state, *etc.*³⁾ Various methods have been employed to determine protein binding of drugs,⁴⁾ although most of them are not suitable for measurements of intact binding *in vivo*. Here, we adopted the semi-microultrafiltration method developed by Imamura *et al.*,⁵⁾ which has the advantages that the plasma need not be diluted, and that the volume of filtrate is so small that the drug-protein equilibrium should not be affected.

The protein binding of salicylic acid has been extensively investigated by many workers,⁶⁾ and it has been reported that salicylates bind mainly to the albumin fraction in plasma proteins.⁷⁾ The present study was carried out to investigate the plasma protein binding of salicylic acid in rabbits and to establish a method for predicting the protein binding *in vivo* from data obtained *in vitro*.

Experimental

Materials—[Carboxyl-¹⁴C] salicylic acid (¹⁴C-SA) was purchased from The Radiochemical Centre Ltd., Amersham, and had a specific activity of 59 mCi/mmol. Unlabeled salicylic acid (SA) was obtained commercially and was recrystallized before use. Rabbit serum albumin (RSA fraction V) was obtained from Miles Laboratories, Inc.

- 1) The preceding paper: Y. Kaneo, S. Iguchi, and H. Nagatomi, *Yakugaku Zasshi*, **94**, 602 (1974).
- 2) Location: *Ichigaya Funagawara-machi, Shinjuku-ku, Tokyo*.
- 3) J.J. Vallner, *J. Pharm. Sci.*, **66**, 447 (1977).
- 4) M.C. Meyer and D.E. Guttman, *J. Pharm. Sci.*, **57**, 895 (1968).
- 5) H. Ichibagase, Y. Imamura, K. Arimori, and M. Sonoda, Abstracts of Papers, 9th Symposium on Drug Metabolism and Action, Kumamoto, November, 1977, p. 141.
- 6) C. Davison and P.K. Smith, *J. Pharmacol. Exp. Ther.*, **133**, 161 (1961); J.A. Sturman and M.J.H. Smith, *J. Pharm. Pharmacol.*, **19**, 621 (1967); J.L. Kucera and F.J. Bullock, *J. Pharm. Pharmacol.*, **21**, 293 (1969); J.F. Zarosinski, S. Keresztes-Nagy, R.F. Mais, and Y.T. Oester, *Biochem. Pharmacol.*, **23**, 1767 (1974).
- 7) W.L. Stafford, *Biochem. Pharmacol.*, **11**, 685 (1962).

Equilibrium Dialysis Method—The equilibrium dialysis procedure was carried out as described previously;⁸⁾ Four ml of 1.92×10^{-4} M RSA solution or 4 ml of rabbit serum solution was placed in a dialysis bag. It was placed in a 30 ml Meyer flask, containing 10 ml of SA solution (0.1 — 2.5×10^{-3} M) and a trace amount of ^{14}C -SA (about $0.2 \mu\text{Ci}$). The flask was shaken at 37° for about 12—14 hr until equilibration was completed. Rabbit serum solution was prepared by dilution of pooled rabbit serum (RS) with buffer, and the albumin concentration was adjusted to about 2×10^{-4} M. In all experiments $1/15$ M phosphate buffer (pH 7.4; isotonic; ionic strength, 0.24) was used.

Concentrations of SA inside and outside the bag were determined as follows. One ml of sample solution was added to 10 ml of Aquasol-2 (New England Nuclear Co.), and ^{14}C -SA in the medium was determined with a liquid scintillation counter (Aloka LSC-651).

Semi-microultrafiltration Method—a) Preparation of Sample Solution: One-fifth ml of SA acetone solution was pipetted into a glass-stoppered tube, and carefully evaporated to dryness. The residual SA was dissolved by adding either 1.5 ml of RSA solution or 1.5 ml of RS, and $50 \mu\text{l}$ of ^{14}C -SA buffer solution having a radioactivity of about $0.18 \mu\text{Ci}$. The contents were equilibrated for about 1 hr at room temperature. The final concentration of SA ranged from 5.16 to $103.2 \mu\text{g/ml}$. In the case of *in vivo* experiments, 1.5 ml of a rabbit plasma specimen was pipetted into a glass-stoppered tube, and $50 \mu\text{l}$ of ^{14}C -SA buffer solution was added. The contents were incubated for about 15 min at room temperature before undergoing the ultrafiltration procedure.

b) Ultrafiltration:⁵⁾ Visking tubing (8/32 Visking Co.) previously swollen in boiling water was tightly ligated at one end with silkworm-gut to form a bag and at the other to form a seal as illustrated in Fig. 1. It was dehydrated by centrifugation for 30 min at 3000 rpm, then left to stand overnight at room temperature. The sample solution described above was introduced into the bag. After incubation for 1 hr, centrifugation of the apparatus for 10 min at 3000 rpm yielded about $80 \mu\text{l}$ of filtrate. The concentration of SA in the filtrate and that inside the bag were determined as described above, using $50 \mu\text{l}$ aliquots. Preliminary experiments showed that the change of albumin concentration in the bag due to the centrifugation was negligible.

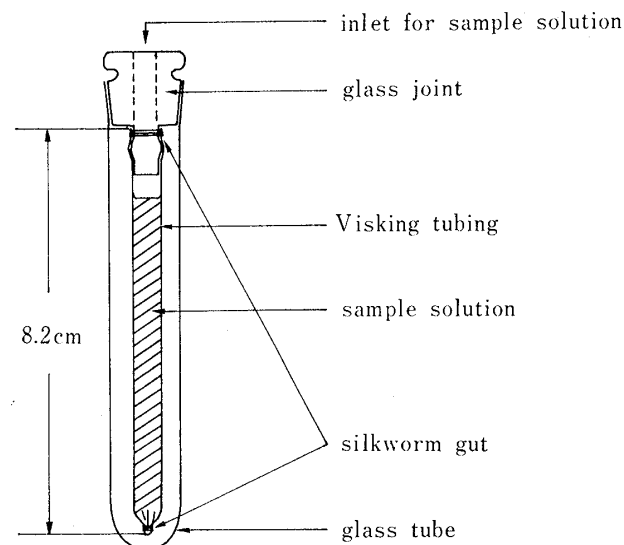

Fig. 1. Semi-microultrafiltration Apparatus according to Imamura *et al.*⁵⁾

test tube using three lots of 0.5 ml of acetone. The acetone was evaporated off, then the residue in the micro test tube was trimethylsilylated with bis(trimethylsilyl)acetamide in pyridine. SA in the plasma sample was estimated as the trimethylsilyl derivative by GLC (Shimadzu GC-4CM PF) with dual flame-ionization detectors. The signal from the detectors was fed into an integrator (Shimadzu Chromatopac E1A) with a 1.0 V full-scale response. Dual coiled glass columns, 1.0 m in length and 3 mm i.d., containing 1.5% OV-17 coated onto $80/100$ mesh chromosorb W, were used. The operating temperatures were as follows: injection ports, 220° ; oven, 150° ; and detectors, 220° . The gas flow rates were as follows: nitrogen, 40 ml/min ; hydrogen, 40 ml/min ; air, approximately 850 ml/min .

c) Measurement of the Binding of SA: The binding (%) of SA in the plasma sampled at 1, 3, 4, 6.5, 10.5, and 24 hr after drug administration was measured by the semi-microultrafiltration method described above.

d) Measurement of the Albumin Concentration and the Total Protein Concentration in Plasma: The albumin concentration in rabbit plasma was measured as follows. One-half ml aliquots of the plasma sample

In Vivo Experimental Method—a) Drug

Administration and Sampling: Male rabbits weighing 3.0 — 3.5 kg which had been fasted for about 24 hr received orally 58 mg/kg of sodium salicylate (equivalent to 50 mg/kg of SA) in 50 ml of aqueous solution. Food was withheld for at least 12 hr after the drug administration. Blood samples (2 to 5 ml) were obtained at 0.5, 1, 2, 3, 4, 4.5, 6.5, 8.5, 10.5, and 24 hr after the drug ingestion. The plasma samples were stored in a freezer until assayed.

b) Measurement of the Plasma Concentration of SA: One-half ml aliquots of a plasma sample were placed in a centrifuge tube containing 1 ml of distilled water, 1 ml of $20 \mu\text{g/ml}$ cinnamic acid aqueous solution as an internal standard, and 1 ml of 2 N HCl. The contents were extracted twice with 20 ml of ether by shaking for 20 min and centrifuging for 5 min at 3000 rpm. The ethereal extract was filtered through anhydrous sodium sulfate to remove water, then evaporated to dryness on a water bath. The residue was transferred into a micro

8) Y. Kaneo, A. Nishikawa, Y. Kato, and S. Kiryu, *Yakugaku Zasshi*, **98**, 1452 (1978).

were pipetted into centrifuge tubes containing 8 ml of saturated sodium sulfate solution (23 g/dl). After addition of 4 ml of ether, each tube was shaken vigorously for 30 sec and centrifuged for 15 min at 3000 rpm. One ml aliquots of the lower water phase were diluted with distilled water to 20 ml, and 1 ml was used for measurement by the method of Lowry *et al.*⁹⁾ Total protein concentrations in plasma were measured, without any pretreatment, using 1 ml of a sample solution prepared by diluting 50 μ l of plasma with distilled water to 20 ml.

e) Measurement of the Plasma pH: The pH of rabbit plasma was measured with a pH meter (Toa HM-18A) using a combination of a glass electrode (Toa HG-5005) for microvolumes of biological fluids (about 0.2 ml) and a reference electrode (Toa HS-205C).

Results and Discussion

Measurement of Protein Binding of SA *In Vitro*

Bindings of SA to RSA and RS were measured by the equilibrium dialysis method. Scatchard plots are shown in Fig. 2. Since these binding isotherms were not linear, binding parameters were estimated by assuming the presence of two classes of binding sites as described previously.¹⁰⁾ Binding site resolution was accomplished by a nonlinear least-squares fit to the following equation using an IBM 370-138 computer.

$$r = n_1 k_1 C / (1 + k_1 C) + n_2 k_2 C / (1 + k_2 C) \quad (1)$$

where k_1 and k_2 are the binding constants corresponding to n_1 and n_2 , the numbers of primary and secondary binding sites, respectively. C is the free drug concentration, and r

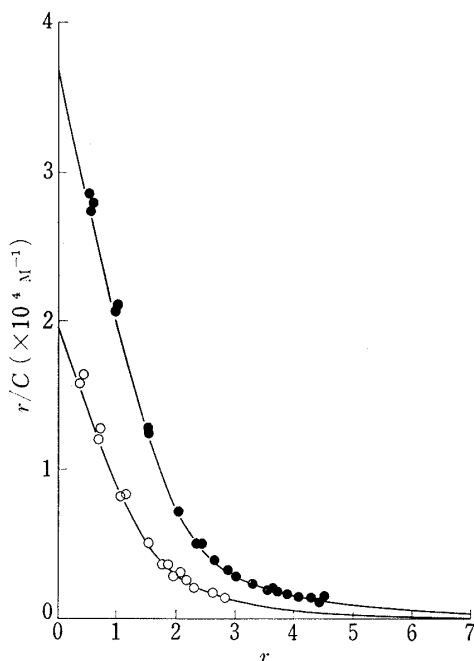

Fig. 2. Scatchard Plot for the Binding of Salicylic Acid to Rabbit Serum Albumin (RSA) and Rabbit Serum (RS) Measured by the Equilibrium Dialysis Method in 1/15 M Phosphate Buffer at pH 7.4 and 37°

The albumin concentration in RS was adjusted to about 2×10^{-4} M by dilution with buffer. All points are experimental while the solid lines show the values computed from the binding parameters.

—●—: 1.92×10^{-4} M RSA.
—○—: RS (albumin concentration: 2.17×10^{-4} M).

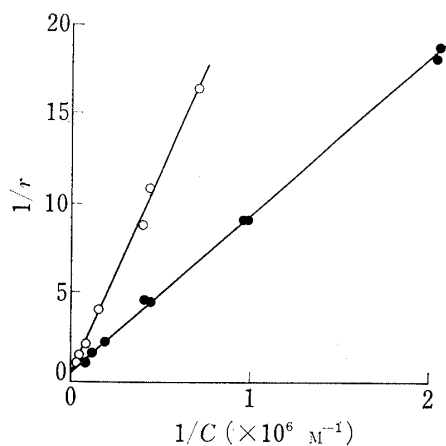

Fig. 3. Double Reciprocal Plot for the Binding of Salicylic Acid to Rabbit Serum Albumin (RSA) and Rabbit Serum (RS) Measured by the Semi-microultrafiltration Method at Room Temperature

RS used in this method was not diluted.

—●—: 6.80×10^{-4} M RSA.

—○—: RS (albumin concentration: 6.80×10^{-4} M).

9) O.H. Lowry, N.J. Rosebrough, A.L. Farr, and R.J. Randall, *J. Biol. Chem.*, **193**, 265 (1951).
10) Y. Kaneo, A. Kai, S. Kiryu, and S. Iguchi, *Yakugaku Zasshi*, **96**, 1412 (1976).

is the molar ratio of bound drug to binding protein. It has been reported that SA binds mainly to the albumin fraction in plasma proteins.⁷⁾ Accordingly, in the case of RS, binding parameters were calculated using the value of albumin concentration, which was regarded as the only protein concentration affecting the binding of SA in plasma. As shown in Table I the binding affinity of SA to RSA was larger than that to RS. This may be due to an interaction between albumin and other plasma proteins and/or to the influence of endogenous substances present in plasma, such as free fatty acids, uric acid, *etc.*^{3,11)}

Next, the semi-microultrafiltration method was employed to measure the binding of SA. The concentration of RSA used was adjusted to 4.76 g/dl, equal to the albumin concentration in pooled rabbit serum, in order to simulate the conditions *in vivo*. The initial concentration of the drug in the filtration bag was varied in the range of about 5 to 100 $\mu\text{g/ml}$, equivalent to that usually observed in clinical use.^{12,13b)} The data obtained were plotted according to Klotz's equation (double reciprocal plot), assuming that only one class of binding sites is present.

$$1/r = 1/nk \cdot 1/C + 1/n \quad (2)$$

The double reciprocal plot, $1/C$ versus $1/r$, gave a single straight line as shown in Fig. 3. The binding parameters, n and k , were estimated using the values of slope and ordinate intercept of the binding regression line, and are shown in Table I. The same tendency observed by the equilibrium dialysis method, *i.e.* that the binding affinity of SA to RSA was higher than to RS, was found by this method. Furthermore, the value of k determined by this method was greater than that of k_1 , the binding constant at the primary site, estimated by the equilibrium dialysis method. This may be due not to a difference between these experimental methods, but to inadequacy of the nonlinear least-square analysis used to evaluate the data obtained in the extremely low drug concentration range by the equilibrium dialysis method.

TABLE I. Binding Parameters for the Interaction of Salicylic Acid with Rabbit Serum Albumin (RSA) and Rabbit Serum (RS)

Protein	Method	n_1	k_1 ($\times 10^4 \text{M}^{-1}$)	n_2	k_2 ($\times 10^2 \text{M}^{-1}$)	$\sum nk$ ($\times 10^4 \text{M}^{-1}$)	N^a
RSA (S.D.)	Equilibrium dialysis	2.16 (0.09)	1.67 (0.13)	6.94 (1.21)	1.52 (0.45)	3.72	45
RS (S.D.)		1.62 (0.09)	1.20 (0.09)	4.39 (1.07)	2.14 (0.88)	2.03	24
RSA	Ultrafiltration	1.67	6.86	—	—	11.5	30
RS		1.77	2.53	—	—	4.47	8

a) The number of data used for the computation.

Therefore, the parameters obtained by the semi-microultrafiltration method are considered to be a good representation of the protein binding when the drug concentration is low as observed in clinical use. Hence, we adopted them for prediction of the protein binding of SA *in vivo*.

Plasma Concentration of SA and Physiological Factors Affecting the Protein Binding in Rabbit

The plasma concentration of SA after oral administration is shown in Fig. 4. Plots show the mean \pm S.D. from 4 rabbits. The maximal plasma concentrations of SA were observed within 1 hr after administration, when a mean level of 143.2 $\mu\text{g/ml}$ was attained. Most of the

11) I. Sjöholm, A. Kober, I. Odar-Cederlöf, and O. Borgå, *Biochem. Pharmacol.*, **25**, 1205 (1976).

12) G. Graham and M. Rowland, *J. Pharm. Sci.*, **61**, 1219 (1972).

13) a) M.J.H. Smith and P.K. Smith, "The Salicylate," Interscience Publishers, New York, 1966, pp. 179—181; b) *Idem, ibid.*, pp. 182—184.

SA in plasma disappeared within 24 hr. Since the plasma concentrations of the main metabolites of salicylate, namely salicylic acid and salicylic glucuronides, are usually not high enough to affect the binding of SA,^{13a)} the plasma concentration and the binding percent of SA alone were determined in this study.

On the other hand, plasma protein binding of a drug may be considerably affected by the concentration of protein. Thus, the concentrations of total protein and albumin in plasma after drug administration were measured. Fig. 5 shows that both concentrations were approximately constant, and did not vary with the plasma sampling or drug administration. When the data in Fig. 5 were plotted with the concentration of albumin as the ordinate and that of total protein as the abscissa, a good correlation ($p < 0.01$) was found, as shown in Fig. 6. The mean values were 4.66 g/dl and 7.03 g/dl, respectively. Plasma pH also affects the protein binding of SA.¹⁴⁾ However, the variation of plasma pH after drug administration was negligibly small (Fig. 7).

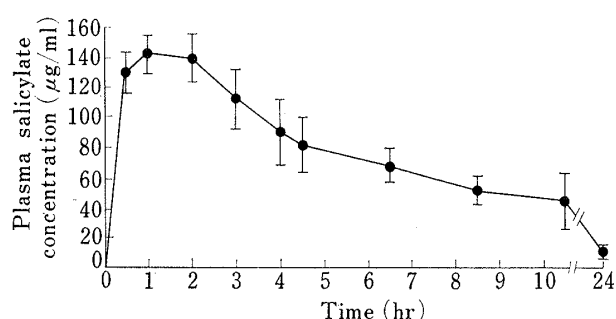

Fig. 4. Plasma Salicylate Concentration in the Rabbit after Oral Administration of 58 mg/kg of Sodium Salicylate (equivalent to 50 mg/kg of Salicylic Acid)

Results are given as means \pm S.D. from 4 rabbits.

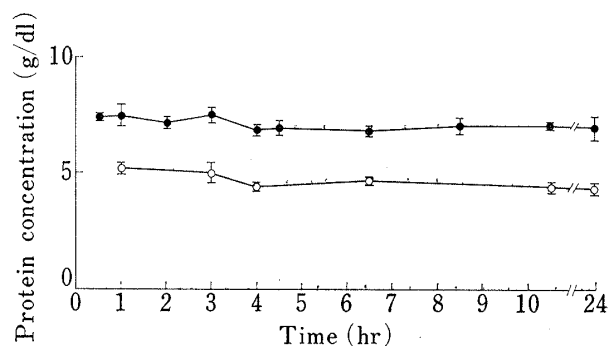

Fig. 5. Total Protein Concentration (●) and Albumin Concentration (○) in Rabbit Plasma as a Function of Time after Oral Administration of 58 mg/kg of Sodium Salicylate

Results are given as means \pm S.D. from 4 rabbits.

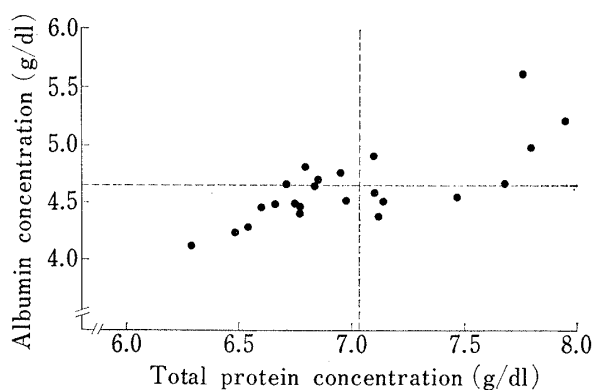

Fig. 6. Relationship between Albumin Concentration and Total Protein Concentration in Rabbit Plasma

The dashed lines indicate the mean values.

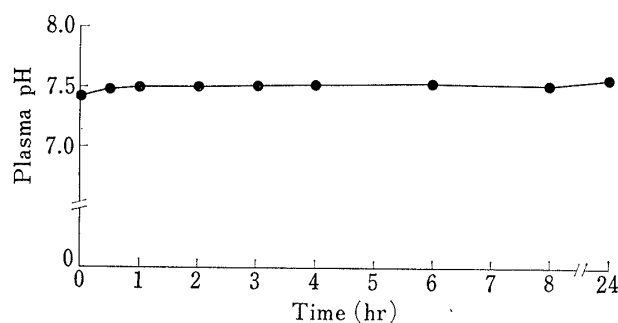

Fig. 7. Plasma pH in the Rabbit as a Function of Time after Oral Administration of 58 mg/kg of Sodium Salicylate

Prediction of the Plasma Protein Binding of SA *in Vivo* from the Data obtained *in Vitro*

As described in the previous paper¹⁾ the free drug concentration, C , at any plasma concentration, $[PL]$, can be evaluated from the following equation:

$$kC^2 + (1 + nk[P_t] - k[PL]) \cdot C - [PL] = 0 \quad (3)$$

14) C.J. Moran and W.H.C. Walker, *Biochem. Pharmacol.*, **17**, 153 (1968).

where $[P_t]$ is the concentration of albumin in the plasma, and n and k are the binding parameters as mentioned above. The percentage binding, β , can be estimated with the following equation using the value of C calculated above.

$$\beta = ([PL] - C) / [PL] \times 100 (\%) \quad (4)$$

TABLE II. Plasma Concentration and Binding of Salicylic Acid after Oral Administration of Sodium Salicylate^{a)}

Time (hr)	Plasma concentration ($\mu\text{g/ml}$)	Binding (%)	Theoretical binding ^{b)} (%)
0.5	129.7 \pm 14.1	—	—
1	143.2 \pm 13.6	88.4 \pm 0.4	89.9 \pm 0.8
2	139.7 \pm 16.4	—	—
3	112.1 \pm 20.2	90.3 \pm 0.8	93.0 \pm 0.9
4	89.3 \pm 21.8	91.4 \pm 1.4	93.2 \pm 1.9
4.5	81.9 \pm 18.7	—	—
6.5	68.2 \pm 11.8	93.2 \pm 0.8	94.7 \pm 0.6
8.5	51.8 \pm 9.5	—	—
10.5	44.1 \pm 19.0	93.4 \pm 0.5	95.8 \pm 0.6
24	10.5 \pm 2.4	95.4 \pm 0.8	96.6 \pm 0.3

Results are given as means \pm S.D. from 4 rabbits.

a) A single 58mg/kg dose (equivalent to 50 mg/kg of salicylic acid).

b) Calculated from the binding parameters.

The following values were substituted for the constants in equation (3): $n=1.77$ and $k=2.53 \times 10^4 \text{ M}^{-1}$, which are the binding parameters of SA to RS measured by the semi-microultrafiltration method (Table I), and $[P_t]=6.66 \times 10^{-4} \text{ M}$ (4.66 g/dl), which is the mean albumin concentration obtained from 4 rabbits (Fig. 6).

Plasma concentration and the observed binding of SA, and the theoretical value of the latter estimated with equation (3) and equation (4) as described above, are summarized in Table II. The theoretical values were in fair agreement with the experimental ones. In

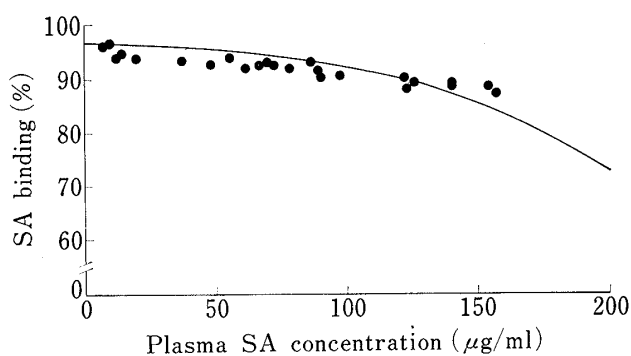

Fig. 8. Plot of Drug Binding (%) versus Plasma Concentration for Salicylic Acid (SA) in the Rabbit

All points are experimental while the solid line shows the values computed from the binding parameters.

addition, Table II indicates that SA is present almost wholly in the bound form *in vivo* (88.4—95.4%), and that the binding (%) increases with decreasing plasma concentration after drug administration, as might be expected. A theoretical curve was estimated using the binding parameters, and is illustrated in Fig. 8. This shows that the percentage of bound drug decreases slowly until the plasma concentration of SA reaches 100 $\mu\text{g/ml}$ but it decreases rapidly above this value. This may be due to saturation of the binding sites following increase of the drug concentration. Furthermore, this theoretical curve is in very good agreement with the experimental values, as shown in Fig. 8. These findings indicate that the plasma protein binding of SA *in vivo* is predictable from data obtained *in vitro*.

Experiments are proceeding to study plasma protein binding of SA in man. Using the experimental method described in this paper, it is hoped that data useful for the prediction of protein binding of drugs *in vivo* will be obtained.

Experiments are proceeding to study plasma protein binding of SA in man. Using the experimental method described in this paper, it is hoped that data useful for the prediction of protein binding of drugs *in vivo* will be obtained.

Acknowledgement The authors wish to thank Dr. T. Goromaru, Tokyo College of Pharmacy, for his valuable advice on the determination of salicylic acid by GLC.