

[Chem. Pharm. Bull.]
33(9)3953—3959(1985)

Studies on Sustained-Release Dosage Forms. III.¹⁾ Preparation of Nifedipine Suppositories and Bioavailability in Rabbits

TSUNEO UMEDA,^a TERUYOSHI YOKOYAMA,^{*,a} NORIAKI OHNISHI,^a
TSUTOMU KURODA,^a YOSHIKI KITA,^a KOJI KURODA,^a
and SHOZO ASADA^b

*Hospital Pharmacy, Kobe University School of Medicine,^a Kusunoki-cho, Chuo-ku, Kobe 650,
Japan and Kobe Women's College of Pharmacy,^b Motoyamakitamachi,
Higashinada-ku, Kobe 658, Japan*

(Received January 9, 1985)

By the use of solid dispersion systems, suppositories having both a fast release and a sustained release of nifedipine were developed. Namely, cellulose acetate phthalate (CAP)-polyethylene glycol (PEG) matrix was prepared as a suppository base by using PEG 4000 as a water-soluble carrier and CAP as a poorly soluble carrier.

Conventional suppositories (use of PEG 4000 alone as a base: C-0), three kinds of CAP-PEG matrix suppositories (use of 5, 10 and 15% (w/w) CAP in the matrix: M-5, M-10 and M-15) and double layer suppositories including nifedipine only in the outside layer (use of 15% CAP in the matrix as a base: D-15) were prepared, and the sustained-release effect and bioavailability of each suppository were examined in rabbits. The M-5 as well as C-0 produced a sharp peak of plasma concentration of nifedipine and did not give a sustained-release effect. The M-10 gave a sustained-release effect, but it was not a desirable preparation because it developed many cracks and broke easily. The M-15 gave a low and plateau plasma level of nifedipine and had no cracks, but the extent of bioavailability was very small. The D-15 enhanced the bioavailability of nifedipine and also gave a sustained-release plasma level of nifedipine. Therefore, it appeared that D-15 was a suitable preparation for our purpose.

Keywords—nifedipine; solid dispersion system; cellulose acetate phthalate-polyethylene glycol matrix; sustained-release suppository; rectal administration; bioavailability

Nifedipine is a highly active Ca²⁺-channel blocker of the excitation-contraction coupling smooth vascular muscle and myocardium,^{2,3)} and is used in the management of angina pectoris and hypertension.⁴⁾ However, nifedipine is a poorly water-soluble drug whose bioavailability is very low when it is administered in crystalline form,⁵⁾ and its biological half-life is very short.^{6,7)} Therefore, several dosage forms of nifedipine have been studied by many investigators in order to enhance its bioavailability and also to prolong the duration of its action.⁸⁾

In this study, we attempted to enhance the bioavailability and also to formulate sustained-release dosage forms of nifedipine by using the solid dispersion technique. Solid dispersion systems involve the dispersion of one or more active ingredients in an inert carrier or matrix in the solid state. It is possible that these systems can be used to obtain a homogeneous distribution of a small amount of drugs in the solid state, to formulate a fast-release priming dose in a sustained-release dosage form, and to formulate sustained-release or prolonged-release regimens of soluble drugs by using poorly soluble or insoluble carriers.⁹⁾ To obtain a matrix having both a fast release and a sustained release, we prepared cellulose acetate phthalate (CAP)-polyethylene glycol (PEG) matrix as a suppository base by using PEG 4000 as a water-soluble carrier and CAP as a poorly soluble carrier. CAP was completely melted in PEG 4000 fusion, and a homogeneous matrix was obtained when the CAP-PEG fusion solidified.

The advantages of using PEG and CAP are their nontoxicity and general applicability to most drugs. PEG has been used for a long time to enhance the bioavailability of water-insoluble drugs by entrapping them.⁹⁾

Furthermore, we designed double layer suppositories which included nifedipine only in the outside layer for the same purpose.

Experimental

Materials—Nifedipine was a gift from Sawai Pharmaceutical Co., Ltd. and PEG 400, PEG 4000 and CAP were purchased from Wako Pure Chemical Industries, Ltd. All other chemicals were of reagent grade.

Method—These experiments were carried out in a dark room because of the high sensitivity of nifedipine to light.

Preparation of Suppositories—1) The conventional suppositories (C-0) were prepared using PEG 4000 as a base and a large mold (Fig. 1-(A)) by the fusion method. 2) The CAP-PEG matrix suppositories (5, 10 and 15% (w/w) CAP in the matrix; see Fig. 2-(A)) were prepared as follows: CAP was completely melted in PEG 4000 fusion, and nifedipine was melted in the CAP-PEG fusion. Then this fusion was poured into a large mold and allowed to solidify at room temperature. The three kinds of CAP-PEG matrix suppositories, which had 5, 10 and 15% CAP in the matrix, were termed M-5, M-10 and M-15, respectively. 3) The double layer suppositories (D-15) as shown in Fig. 2-(B) were prepared by using two molds as shown in Fig. 1-(A), (B). First, the inner layer was prepared by pouring the base into a small mold and allowing it to solidify at room temperature. Subsequently, nifedipine was fused in the same base; this fusion was poured into a large mold, and then the inner layer was quickly inserted into the center of this large mold before solidification of the fusion in the large mold. The base used in both layers was the same as that of M-15. The weight of the inner layer was equal to that of the outside layer. The content of nifedipine in all preparations was 2.5 mg. 4) For morphological experiments in rats, suppositories without nifedipine (size: diameter 4 mm, length 5 mm) were prepared by using the same base as M-15.

Release of Nifedipine from Each Suppository—The release tests were carried out according to the method of Muranishi *et al.*¹⁰⁾ The test solution was 500 ml of 1/10 M phosphate buffer solution (pH 7.2). To observe easily the difference of release rate of nifedipine from each suppository *in vitro*, each suppository was placed directly on the metallic net of a plastic cylindrical cell without an artificial membrane. The plastic cylindrical cell was immersed in the test solution at a constant temperature (37 °C) and then a steel stirrer rod in the test solution was rotated at 150 rpm. Dissolved drug was continuously assayed spectrophotometrically at 328 nm (Hitachi, model 200-20 spectrophotometer) by circulating the solution through a flow cell with a glass filter (Pyrex 75 μ m).

Observation by Scanning Electron Microscope—The surface of M-15 was observed with a scanning electron microscope (Nihon Denshi, JMS-T20).

Animal Experiments—**Intravenous Administration:** White male rabbits weighing from 3.0 to 3.5 kg were used. Nifedipine (0.625 mg/ml) dissolved in 30% PEG 400 solution was intravenously injected, and then blood samples were taken at appropriate times.

Rectal Administration: White male rabbits weighing from 3.0 to 3.5 kg were fasted for 36 h prior to the experiments but allowed free access to water. After rectal administration, blood samples were collected from an ear

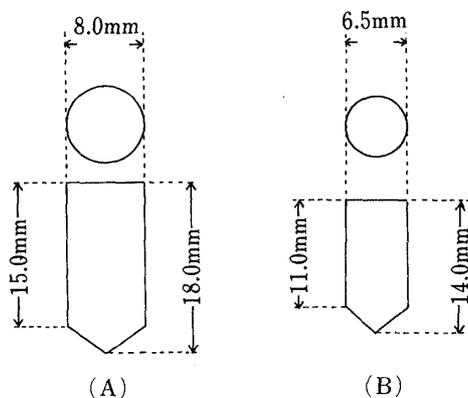

Fig. 1. Mold Dimensions

(A) large mold. (B) small mold.

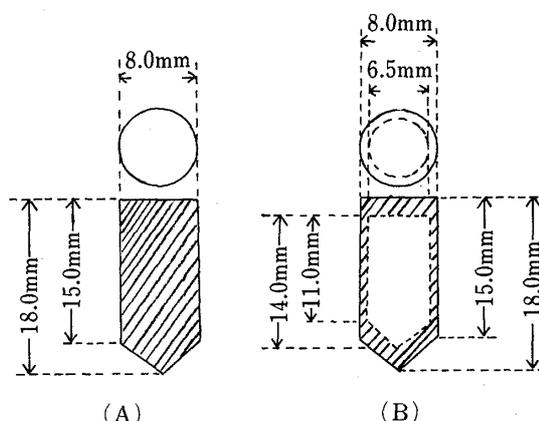

Fig. 2. Design of Each Suppository

(A) C-0, M-5, M-10 and M-15. (B) D-15. Nifedipine was included in the shaded portion. The abbreviations are described in the text.

vein at regular intervals. The plasma samples were frozen and stored at -5°C until assay.

Measurements of Nifedipine in Plasma—The gas chromatographic method reported by Jakobsen *et al.*¹¹⁾ was applied with a slight modification as follows: 0.5 ml plasma was added to a 10 ml glass-stopped centrifuge tube containing 0.5 ml of 1/10 M phosphate buffer solution (pH 7.2), and mixed. Then 0.5 ml of benzene containing an internal standard (100 ng/ml griseofulvin) was added to the mixture. The tube was vigorously shaken for 10 min. After centrifugation (3500 rpm for 5 min), 3 μl of the organic phase was injected into a gas chromatograph equipped with a ^{63}Ni electron capture detector (Shimadzu, GC-8A). A glass column (100 cm \times 3.2 i.d.) packed with 5% OV-7 Gas Chrom Q, 80–100 mesh (Wako Pure Chemical Industries, Ltd.) was used. The conditions for analysis were as follows: column temperature 270°C , detector temperature 310°C , and carrier gas (nitrogen) flow-rate 60 ml/min.

Morphological Studies on Rectal Tissue in Rats—Male, Wistar rats weighing from 230 to 250 g were fasted for 16 h prior to experiments but allowed free access to water. The suppository without nifedipine (size: diameter 4 mm, length 5 mm) was administered into the rectal loop of a rat. After 1 h, the rectum was isolated, rinsed with a saline solution, fixed in 10% formalin and cut into slices. The slices were stained with hematoxylin–eosin, and observed under a light microscope.

Results and Discussion

Release of Nifedipine from Each Suppository

The release rate profiles of nifedipine from C-0, M-5, M-10, M-15 and D-15 are shown in Fig. 3. Each curve represents the average of at least three experiments. It was found that the release rate of nifedipine from each suppository decreased with increase in the content of CAP in the base. Therefore, the release rate of nifedipine from the CAP–PEG matrix was controlled by CAP.

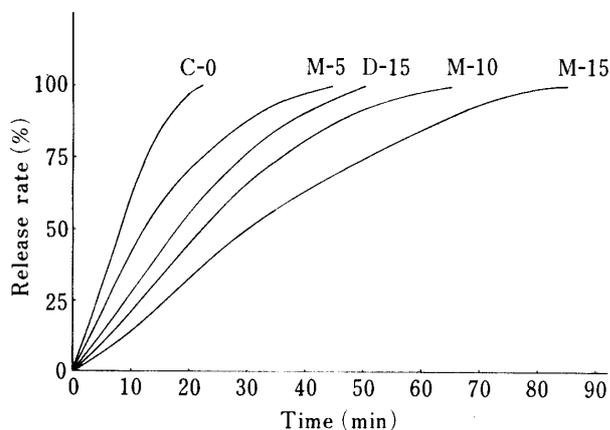

Fig. 3. Release Rate of Nifedipine from Each Suppository

The abbreviations are described in the text.

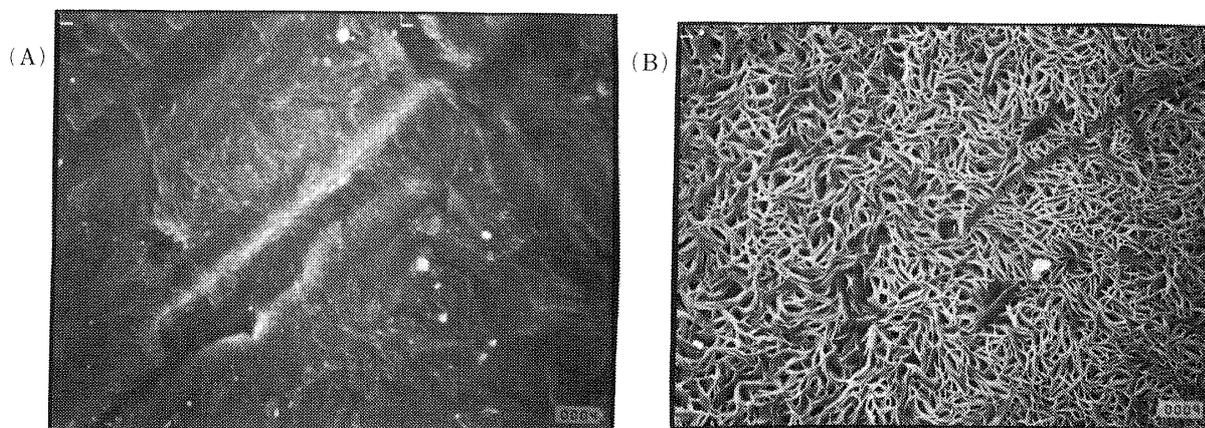

Fig. 4. Scanning Electron Micrographs of M-15 ($\times 500$)

(A) the surface of M-15 before the release test. (B) the surface of M-15 at 15 min after the start of the release test.

Release Mechanism of Nifedipine from the CAP-PEG Matrix

By the use of a scanning electron microscope, a further study was performed to clarify the mechanism of controlled release of nifedipine from the CAP-PEG matrix. In Fig. 4, (A) represents the surface of M-15 before the release test, and (B) shows the surface of M-15 at 15 min after the start of the release test. From these photographs, it is clear that pore formation and the development of a network structure at the surface of M-15 occur during the release process. The formation of the pores and network structure contributes to the difference of dissolution rate in the release process between PEG and CAP.¹²⁾ In this case, superficial erosion also proceeds at the surface of M-15, because CAP dissolves gradually in the test solution (1/10 M phosphate buffer solution at pH 7.2).¹³⁾

From these results, the controlled release of nifedipine from each CAP-PEG matrix can be presumed to occur as follows: first, the PEG-entrapped nifedipine at the surface of the suppository dissolves faster than CAP in the test solution. Secondly, the pores and network structure appear. Because of this network structure, the test solution is prevented from reaching the inner portion of the suppository. Thirdly, the superficial erosion of CAP proceeds. These phenomena continue until the suppository is completely dissolved.

Plasma Concentrations of Nifedipine after Rectal Administration

In order to prevent anginal attacks early in the morning by dosing nifedipine before bedtime, it may be necessary to maintain a suitable concentration of nifedipine in plasma for at least 10 h in humans. Therefore, in this experiment using a rabbit, our goal was to maintain a roughly constant plasma concentration of nifedipine in a rabbit for over 10 h after the administration of CAP-PEG matrix suppositories.

The plasma levels of nifedipine after rectal administration of C-0 are shown in Fig. 5, and those in the cases of M-5, M-10 and M-15 are shown in Fig. 6. The absorption of nifedipine from C-0 was very rapid, and the mean maximum plasma concentration (C_{max}) was 664.0 ng/ml \pm 112.3 (mean \pm S.D.) at 45 min; nifedipine was eliminated almost entirely from the plasma at 6 h. In the case of M-5, C_{max} was 419.8 ng/ml \pm 62.7 (mean \pm S.D.) at 90 min, and nifedipine was eliminated from the plasma at 8 h. The M-10 produced a sustained plateau plasma level of nifedipine from 30 min to 2 h without a lag time, and the plasma level of nifedipine was

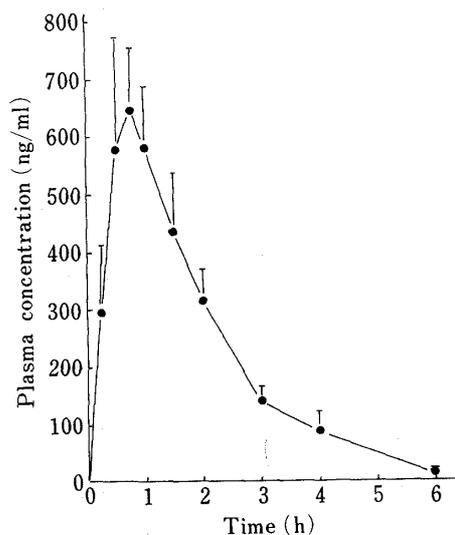

Fig. 5. Plasma Concentrations of Nifedipine after Rectal Administration of C-0

Each point represents the average \pm S.D.

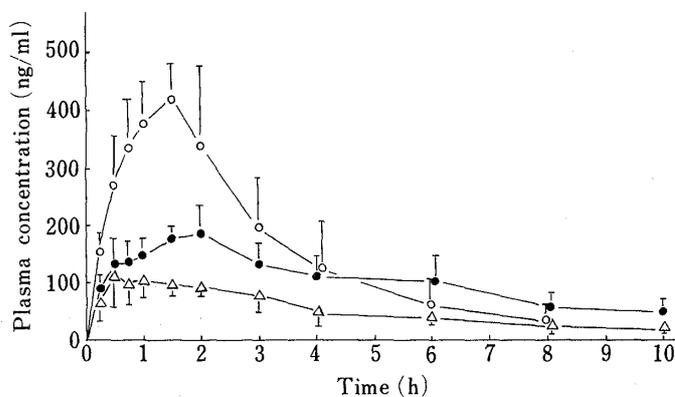

Fig. 6. Plasma Concentrations of Nifedipine after Rectal Administration of CAP-PEG Matrix Suppositories

○, M-5; ●, M-10; △, M-15. Each point represents the average \pm S.D.

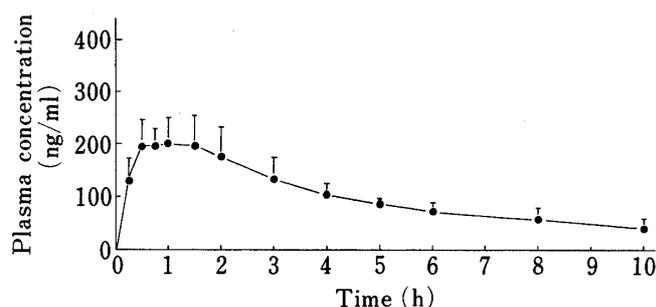

Fig. 7. Plasma Concentrations of Nifedipine after Rectal Administration of D-15

Each point represents the average \pm S.D.

TABLE I. $[AUC]_0^\infty$ Values after Rectal Administration of Each Suppository and after Intravenous Injection

Form	Dose (mg)	N^a	$[AUC]$ (ng · h/ml) ^b	EBA ^c (%)
<i>i.v.</i>	0.625	5	472.6 \pm 130.5	
C-0	2.5	6	1359.1 \pm 237.7	70.2
M-5	2.5	4	1517.8 \pm 664.7	78.3
M-10	2.5	5	1380.0 \pm 234.1	71.3
M-15	2.5	5	608.6 \pm 24.4	31.4
D-15	2.5	7	1419.8 \pm 296.4	73.4

a) The number of rabbits used. *b*) Calcd by use of the trapezoidal rule with extrapolation to infinite time. Each value represents the average \pm S.D. *c*) Extent of bioavailability: $\frac{[AUC]_0^\infty \text{ sup}/\text{dose}_{\text{sup}}}{[AUC]_0^\infty \text{ i.v.}/\text{dose}_{\text{i.v.}}}$

The abbreviations are described in the text.

maintained for over 10 h. In the case of M-15, a low and plateau plasma level of nifedipine was maintained for over 10 h.

The mean area under the plasma concentration vs. time curve $[AUC]_0^\infty$ was calculated from the time course of plasma concentration by the linear trapezoidal method with extrapolation to infinite time. The $[AUC]_0^\infty$ values and extent of bioavailability (EBA) after rectal administration of each suppository and intravenous injection of nifedipine are summarized in Table I. As shown in Table I, adjusting for the dose administered, the EBA values of the four suppositories (except for M-15) were between 70.2% and 78.3% on average.

From these results, it was found that M-5 as well as C-0 produced a sharp peak of plasma concentration and did not give a sustained-release effect, and that M-10 gave a sustained release of nifedipine. However, M-10 is an unfavorable preparation because it develops many cracks and it breaks easily. In the case of M-15, its $[AUC]_0^\infty$ value was only half that of the other suppositories. However, it had no cracks and gave a sustained plateau plasma level of nifedipine.

The reason for the small $[AUC]_0^\infty$ value of M-15 may be that the content of CAP is so high that the pores are smaller and network structure tighter, so that the rectal fluid is unable to reach the inner portion of M-15, and the superficial erosion proceeds more slowly. Thus, more time may be required for M-15 to dissolve completely in the rectal fluid. In this experiment, about one half of the M-15 remained in the rectum of a rabbit at 10 h after administration.

We tried to enhance the $[AUC]_0^\infty$ value of M-15 by incorporating nifedipine only in the outside layer which could be dissolved in the rectal fluid of a rabbit within 10 h. Namely, D-15 containing nifedipine (2.5 mg) only in the outside layer was prepared by using the same base as M-15. As shown in Fig. 7, D-15 gave a plateau plasma level of nifedipine which was twice

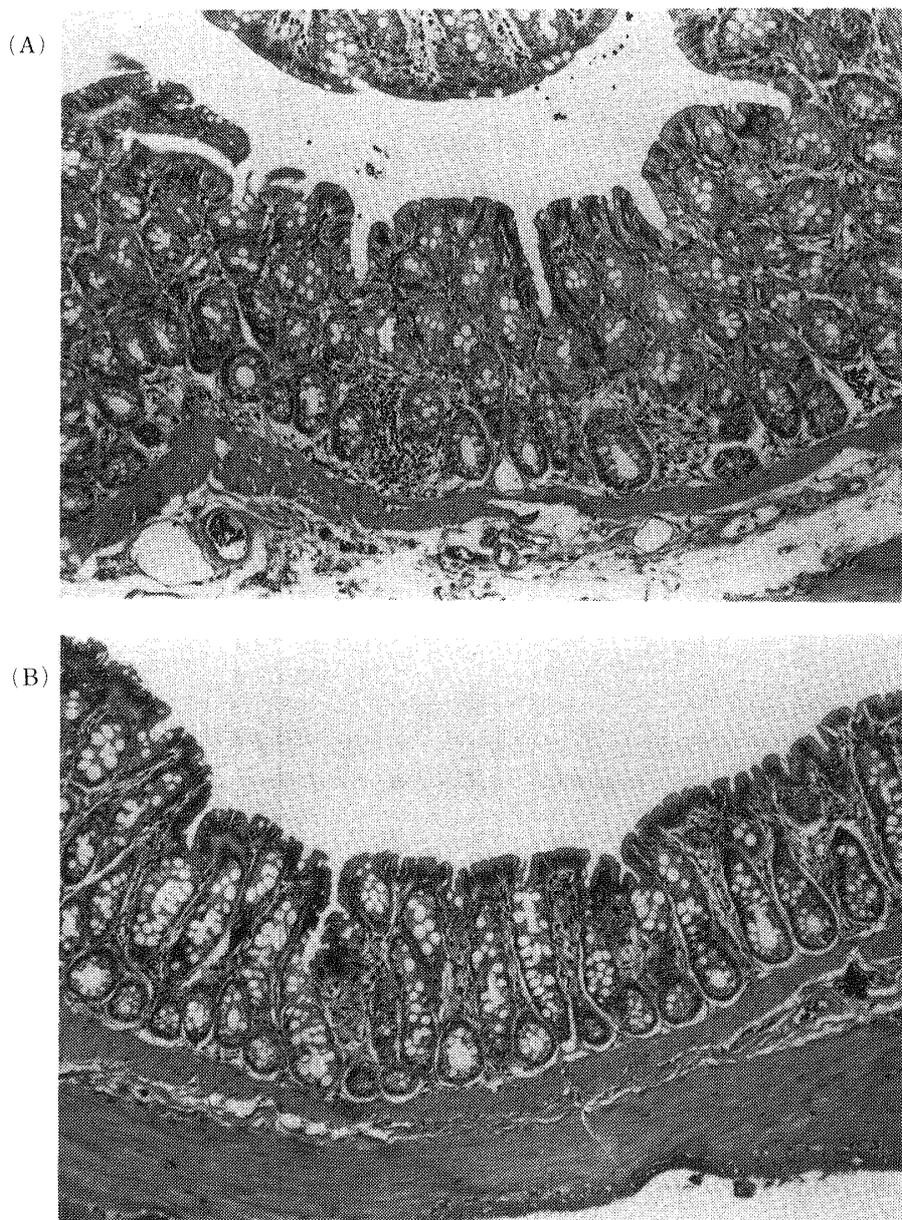

Fig. 8. Histological Observation of the Rectal Mucosa after Administration of 15% CAP-PEG Matrix Suppository without Nifedipine in a Rat ($\times 120$)

(A) the control (no administration). (B) after administration of 15% CAP-PEG matrix suppository.

that obtained with M-15. Its $[AUC]_0^\infty$ value was also about twice that of M-15, as shown in Table I. It appeared that D-15 provided enhanced bioavailability of nifedipine and a sustained plateau plasma level without producing an excessively high peak level in the plasma.

Morphological Studies on Rectal Tissue in Rats

For observation of the rectal mucosal damage caused by the CAP-PEG matrix, the suppository without nifedipine (size: diameter 4 mm, length 5 mm) was administered in the rectal loop of a rat. As illustrated in the photographs of Fig. 8, no mucosal damage caused by the CAP-PEG matrix was observed as compared with the control. This result indicated that the CAP-PEG matrix is suitable for use as a suppository base.

Conclusion

It was found that in CAP-PEG matrix suppositories, PEG enhanced the bioavailability of nifedipine, and CAP controlled the release rate of the PEG-entrapped nifedipine by the formation of pores and network structure. The CAP-PEG matrix seems to be suitable for the development of a rectal delivery formulation with a controlled drug release rate.

The D-15 enhanced the bioavailability of nifedipine and gave a sustained-release characteristic without causing an excessively high peak level in plasma. Therefore, D-15 is a suitable dosage form for obtaining a sustained release of nifedipine.

Additional studies are in progress to examine the feasibility of oral dosage forms based on this dispersion system, and moreover the utilization of other drugs and other cellulose derivatives.

Acknowledgement The authors are grateful to Dr. Satoshi Okada, Department of Pathology, Kobe University Hospital, for the histological observation of the rectal mucosa, and to Sawai Pharmaceutical Co., Ltd. for a gift of nifedipine.

References and Notes

- 1) T. Umeda, A. Matsuzawa, T. Yokoyama, K. Kuroda, and T. Kuroda, *Chem. Pharm. Bull.*, **31**, 2793 (1983); T. Kuroda, T. Yokoyama, T. Umeda, A. Matsuzawa, K. Kuroda, and S. Asada, *ibid.*, **31**, 3319 (1983).
- 2) A. Fleckenstein, H. Tritthart, H.-J. Döring, and K. Y. Byon, *Arzneim.-Forsch.*, **22**, 22 (1972).
- 3) G. Grün and A. Fleckenstein, *Arzneim.-Forsch.*, **22**, 334 (1972).
- 4) G. Mabuchi, H. Kikuchi, and E. Kimura, *Shinzo*, **3**, 1325 (1971).
- 5) I. Sugimoto, K. Sasaki, A. Kuchiki, T. Ishihara, and H. Nakagawa, *Chem. Pharm. Bull.*, **30**, 4479 (1982).
- 6) K. D. Raemisch and J. Sommer, *Hypertension, Supp. II*, **5** II-18 (1983).
- 7) T. S. Foster, S. R. Hamann, V. R. Richards, P. J. Bryany, D. A. Graves, and R. G. McAllister, *J. Clin. Pharmacol.*, **23**, 161 (1983).
- 8) A. Hasegawa, H. Nakagawa, and I. Sugimoto, *Yakugaku Zasshi*, **104**, 485 (1984).
- 9) W. L. Chiou and S. Riegelman, *J. Pharm. Sci.*, **60**, 1281 (1971).
- 10) S. Muranishi, Y. Okubo, and H. Sezaki, *Yakuzaigaku*, **39**, 1 (1979).
- 11) P. Jakobsen, O. L. Pedersen, and E. Mikkelsen, *J. Chromatogr.*, **162**, 81 (1979).
- 12) Y. Samuelov, M. Donbrow, and M. Friedman, *J. Pharm. Sci.*, **68**, 325 (1979).
- 13) K. Heilmann, "Therapeutic Systems," Georg Thieme Publishers, Stuttgart, 1978, pp. 37-39.