

[Chem. Pharm. Bull.]  
34(7)2950-2956(1986)

## Disposition and Pharmacokinetics of Valproic Acid in Rats

TARO OGISO,\* YOSHIMASA ITO, MASAHIRO IWAKI,  
and TORU YAMAHATA

*Faculty of Pharmaceutical Sciences, Kinki University,  
Kowakae 3-4-1, Higashi-osaka, Osaka 577, Japan*

(Received September 20, 1985)

The initial decline in blood concentration of valproic acid (VPA) was followed by a first-order process in rats given the drug intravenously (i.v.) (60 mg/kg) or orally (80 mg/kg), but later a secondary increase in drug concentration, resulting from enterohepatic circulation of free and conjugated drugs, was observed. In order to describe the blood concentration pattern of VPA with its pronounced secondary peak, a pharmacokinetic model consisting of central, bile and intestinal compartments was applied. Inclusion in the model of  $n$  segments ( $n=4$  in the i.v. dose and  $n=5$  in the oral) of gut lumen for drug transfer from the bile compartment to the absorption compartment improved the agreement between observed and predicted plasma VPA levels. Measurements of the extent of biliary excretion and reabsorption of VPA from bile in bile duct-cannulated rats were done to calculate some parameters. The pharmacokinetic model was justified by the good agreement with observed data obtained after i.v. and oral administrations of VPA in rats. This model was considerably superior to a standard two-compartment pharmacokinetic model.

**Keywords**—pharmacokinetic model; valproic acid; multicompartment model; enterohepatic circulation; bile excretion

Valproic acid (VPA) is an anticonvulsant drug which has found increasing use in the treatment of generalized epilepsy. The pharmacokinetics of VPA has been studied extensively in patients and animals. In intact rats, a secondary increase in the concentration of VPA in the blood is observed after a single intravenous (i.v.) or oral dose and can be explained in terms of enterohepatic circulation of the free and conjugated forms of the drug.<sup>1,2)</sup> Lawyer *et al.* have reported that the initial decline in blood concentration of VPA following redistribution in bile-exteriorized rats is dose-dependent at higher doses (above 150 mg/kg) and can be described by the two-compartment open model with Michaelis-Menten elimination kinetics, while the decline follows first-order kinetics only at lower doses.<sup>3)</sup> However, the pharmacokinetics of VPA in intact rats has not been characterized satisfactorily.

In order to explain the plasma concentration profile of VPA in the presence of significant enterohepatic circulation, we have applied a pharmacokinetic model consisting of the central compartment (C), the bile compartment (B) and  $n$  segments of gut lumen ( $G_i$ ). Furthermore, the biliary excretion and the plasma elimination of VPA in bile-exteriorized rats, and the reabsorption of VPA excreted in bile, were examined in order to calculate the defined pharmacokinetic parameters.

### Materials and Methods

**Materials**—1) Reagents: Sodium valproate (VPA-Na) was kindly supplied by Kyowa Hakko Kogyo Co., Ltd. (Tokyo, Japan). Cycloheptanecarboxylic acid, an internal standard for gas-liquid chromatography, was purchased from Tokyo Kasei Kogyo Co., Ltd. (Tokyo, Japan).  $\beta$ -Glucuronidase/arylsulfatase (2 ml) was purchased from Boehringer Mannheim Co. Other chemicals used were of special grade.

2) Animals: Male Wistar rats (250–350 g) were used throughout this experiment. Animals had free access to

food (MF, Oriental Yeast Co., Ltd.) and water before experiments.

**Experimental Schedules**—1) Single Intravenous Administration to Intact Rats: VPA-Na (60 mg/kg as VPA) was dissolved in saline and administered intravenously into the jugular or femoral vein of intact rats. Blood samples (0.15—0.25 ml) were collected periodically from the jugular vein with a heparinized syringe. Three different groups (0.167—6, 2—8 and 8—18 h sampling times) were used.

2) Single Oral Administration to Intact Rats: VPA-Na (80 mg/kg as VPA) was dissolved in 2% acacia solution and administered orally to intact rats. Blood samples were collected periodically from the jugular vein, from three different groups (2—20 min, 0.5—10 h and 10—20 h sampling times).

3) Biliary Excretion: One day before the experiment, the common bile duct was cannulated with polyethylene tubing (PE-10), which was passed subcutaneously to the back, under pentobarbital anesthesia (40 mg/kg, intraperitoneally, i.p.). VPA-Na (60 mg/kg as VPA) was dissolved in saline and administered into the jugular vein of bile duct-cannulated rats. Blood samples were collected periodically from the jugular vein 0.16—6 h after dosing. Bile samples were collected at 1 h intervals for 6 h through the tubing.

4) Reabsorption of VPA in Bile: Under anesthesia (pentobarbital, 40 mg/kg, i.p.), the bile duct of a donor rat was connected with that of an acceptor rat with polyethylene tubing (PE-10). The bile of the acceptor rat was discarded through polyethylene tubing. Thus, VPA in the bile from the donor rat following drug administration (VPA, 60 mg/kg) was absorbed from the gut of the acceptor rat. Blood samples were collected periodically from the jugular vein of the acceptor rat 0.5—8 h after dosing.

**Determination of VPA in Plasma and Bile**—VPA in plasma was determined according to the method of Vree *et al.*<sup>4)</sup> with slight modifications. Each blood sample was immediately centrifuged at  $1400 \times g$  for 10 min and plasma was separated. An aliquot (100  $\mu$ l) of plasma was added to a mixture of 100  $\mu$ l of 3 N sulfuric acid, 200  $\mu$ l of internal standard (cycloheptanecarboxylic acid, 40 or 4 nl/ml in chloroform) and 2 ml of chloroform. The mixture was shaken for 10 min and then centrifuged. The chloroform layer was dried with a small amount of anhydrous sodium sulfate, then concentrated under reduced pressure, and 2—6  $\mu$ l of the chloroform layer was injected into the gas chromatograph (Shimadzu, model GC-4MC, with a hydrogen flame ionization detector, 5% free fatty acid phase (FFAP), substance SP 1000, on 60—80 mesh Gas-Chrome Q, 3 mm  $\times$  2 m). The detector temperature was 225  $^{\circ}$ C and the column oven was programmed from 110 to 170  $^{\circ}$ C at 4  $^{\circ}$ C/min. Nitrogen was used as the carrier gas at a flow rate of 30 ml/min. The conjugate of VPA in the bile sample was hydrolyzed with  $\beta$ -glucuronidase/arylsulfatase solution (0.01 ml, which was diluted with 0.2 ml of 0.05 M acetate buffer, pH 5, at 37  $^{\circ}$ C for 6 h), and free VPA produced was determined according to the method described above. The unconjugated VPA in the bile, without treatment with enzymes, was determined by the same method.

**Pharmacokinetic Model and Theory**—For high doses of VPA (above 150 mg/kg), Michaelis–Menten saturable elimination kinetics and for low doses, first-order elimination kinetics are applicable to the concentration profiles of VPA in bile-exteriorized rats.<sup>3)</sup> At the low dose (60 mg/kg) used in our study, therefore, the transfer process between compartments was assumed to follow first-order kinetics.

The proposed pharmacokinetic model was developed with reference to the compartment model presented by Koizumi *et al.*<sup>5)</sup> A portion of the drug distributed in the central compartment, C, after i.v. administration is secreted into the bile compartment, B, which is the bile fraction in the liver. This bile, excreted into the duodenum, is transferred to the gut lumen and a part of the drug in the lumen, after hydrolysis, is reabsorbed. Since the hydrolysis process is rate limiting, and the enterohepatic circulation contributes to a longer residence time in VPA disposition, the relatively slow absorption of the drug was considered to involve several segments of the gut lumen,  $G_1$ — $G_n$ . The model presented in Fig. 1a can be expressed mathematically with the following simultaneous differential equations:

$$\frac{dX_c}{dt} = -(k_e + k_s)X_c + k_a X_{gn} \quad (1)$$

$$\frac{dX_b}{dt} = k_s X_c - k_b X_b \quad (2)$$

$$\frac{dX_{g1}}{dt} = k_b X_b - k_t X_{g1} \quad (3)$$

$$\frac{dX_{gi}}{dt} = k_t X_{g(i-1)} - k_t X_{gi} \quad i=2, 3 \dots n-1 \quad (4)$$

$$\frac{dX_{gn}}{dt} = k_t X_{g(n-1)} - (k_t + k_a)X_{gn} \quad (5)$$

$$C_p = X_c/V_d \quad (6)$$

where  $X_c$ ,  $X_b$  and  $X_{gi}$  are the amount of drug in the central compartment, in the bile compartment and in the  $i$ -th

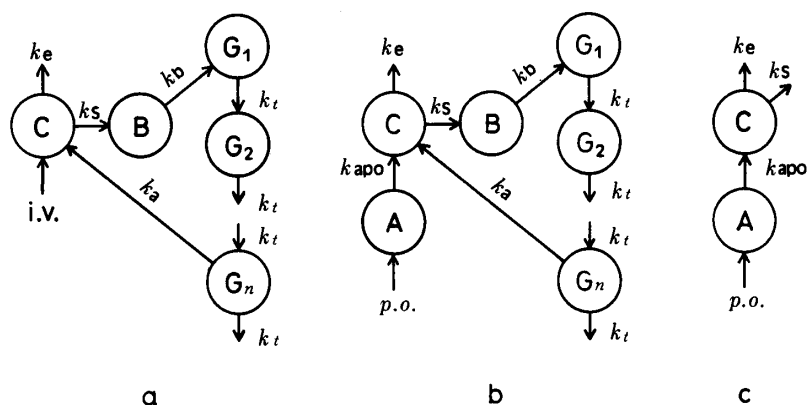

Fig. 1. Pharmacokinetic Models (Including Enterohepatic Circulation) of Valproic Acid in Intact Rats

- Intact rats after i.v. administration.
- Intact rats after oral administration.
- Bile-exteriorized rats after oral administration.

Compartment C is the central compartment, compartment B is the bile compartment, compartment  $G_i$  is the  $i$ -th segment of gut lumen and compartment A is the absorption compartment.

segment of the gut lumen, respectively;  $k$ 's with subscripts are first-order rate constants of the respective steps,  $V_d$  is the volume of the central compartment and  $C_p$  is the concentration of drug in the central compartment. As initial conditions,  $X_b=0$ ,  $X_{gi}=0$  and  $X_c=D$ , where  $D$  is the dose. The model proposed in Fig. 1b, for oral administration of VPA, can be expressed mathematically with the following simultaneous differential equations and Eqs. 2—6:

$$\frac{dX_a}{dt} = -k_{apo}X_a \quad (7)$$

$$\frac{dX_c}{dt} = -(k_e + k_s)X_c + k_aX_{gn} + k_{apo}X_a \quad (8)$$

As initial conditions,  $X_a=FD$ ,  $X_c=0$ ,  $X_b=0$  and  $X_{gi}=0$ , where  $F$  is the fraction absorbed from absorption site A.

**Data Analysis**—A least-squares fit program MULTI (RUNGE)<sup>6</sup> was used to calculate pharmacokinetic parameters. Discrimination among the models with various numbers  $n$  of segments was done in terms of the residual sum of squares (ss).

## Results

### Plasma Concentration and Biliary Excretion of VPA in Bile-Exteriorized and Bile-Linked Rats

The initial decline in plasma VPA concentration was followed by a first-order process in bile-exteriorized rats and the biliary excretion of VPA was rapid, as shown in Fig. 2. Total biliary excretion of VPA (free and conjugated) in 6 h after i.v. dosing was about 54% of the dose. Approximately 92% of total VPA excreted in the bile during 6 h was secreted within 2 h after administration (Fig. 2b), and about 84% of total VPA excreted in bile was glucuronide and sulfate and 16% was free VPA. Pharmacokinetic data for VPA in bile-exteriorized rats were analyzed in terms of the model shown in Fig. 3a; the model was adapted to the observed plasma concentrations and amounts of drug excreted into the bile after i.v. administration to rats. The cumulative amount of drug in the bile collected through the cannula corresponds to the amount of drug in compartment  $G_1$ . The parameters,  $k_e$ ,  $k_s$ ,  $k_b$  and  $V_d$ , obtained are listed in the upper part of Table I. The model, adapted to the observed values of plasma concentration in acceptor rats after i.v. administration of VPA to donor rats, shown in Fig. 3b is applicable to the kinetics of VPA in bile duct-linked rats. Using various  $n$  values (2—8) and parameters  $k_e$ ,  $k_s$ ,  $k_b$  and  $V_d$  listed in Table I, the best-fit parameters,  $k_t$  and  $k_a$ , can be calculated.

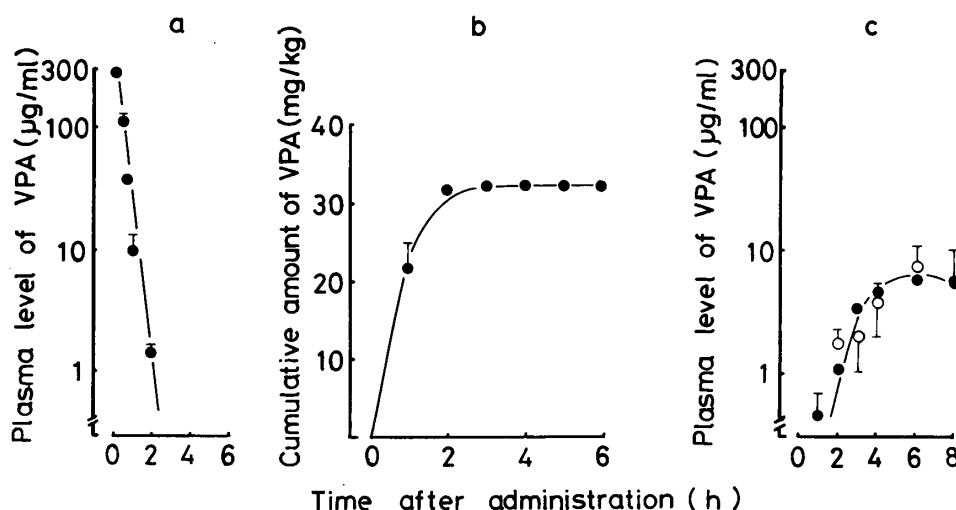

Fig. 2. Plasma Concentration and Biliary Excretion of VPA in Bile-Exteriorized and Bile-Linked Rats

- a) Plasma concentration in bile-exteriorized rats.  
 b) Cumulative biliary excretion of VPA in bile-exteriorized rats.  
 c) Plasma concentration in bile duct-linked rats (●) and intact rats (○).

The solid line represents a least-squares fitting curve calculated by means of the compartment model and each point represents a mean observed value with S.D.  
 Dose: VPA-Na 69.1 mg (VPA 60 mg)/kg.

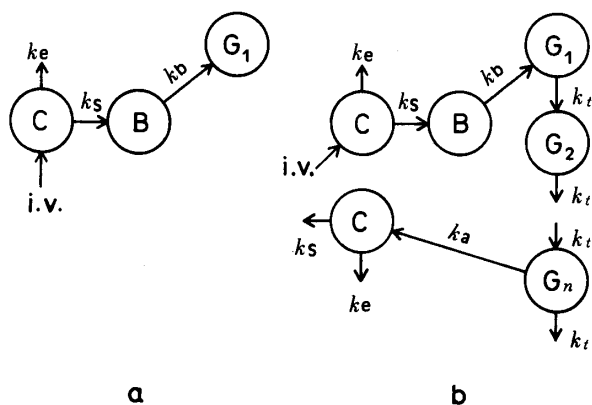

Fig. 3. Pharmacokinetic Models of Valproic Acid in Bile-Exteriorized Rats

- a) Biliary excretion of VPA in bile-exteriorized rats.  
 b) Bile duct-linked rats.

TABLE I. Pharmacokinetic Parameters of VPA

Parameter	
$k_e$ ( $h^{-1}$ )	$1.357 \pm 0.228$
$k_s$ ( $h^{-1}$ )	$1.608 \pm 0.235$
$k_b$ ( $h^{-1}$ )	$1.912 \pm 1.731$
$V_d$ (l/kg)	$0.143 \pm 0.007$
$k_t$ ( $h^{-1}$ )	$0.521 \pm 0.044$
$k_a$ ( $h^{-1}$ )	$0.932 \pm 0.175$
$k_{apo}$ ( $h^{-1}$ )	$1.698 \pm 0.099$
$F$	$0.944 \pm 0.082$

Each value represents the mean  $\pm$  S.D.

### Plasma Concentrations after i.v. Administration in Intact Rats

Plasma concentrations of VPA after i.v. administration to intact rats are shown by closed circles in Fig. 4. Initial rapid elimination of VPA and a secondary increase in drug concentration in plasma about 3–6 h after dosing, due to the enterohepatic circulation of VPA, were observed, with a slow rate of elimination at the latter time stage. The time course of plasma concentration after i.v. administration was simulated using the model, with various  $n$  values, shown in Fig. 1a. A good fit was not obtained with values of  $n < 3$  and  $n > 5$ , and  $n = 4$  gave the minimum ss value. The simulation curve based on the 4-segment model is shown in Fig. 4 and the parameters,  $k_t$  and  $k_a$ , are listed in Table I.

### Plasma Concentrations of VPA after Oral Administration in Intact Rats

A pharmacokinetic model of intact rats after oral administration is shown in Fig. 1b. The drug passed into the absorption site, A, is absorbed with the absorption rate constant  $k_{apo}$ .

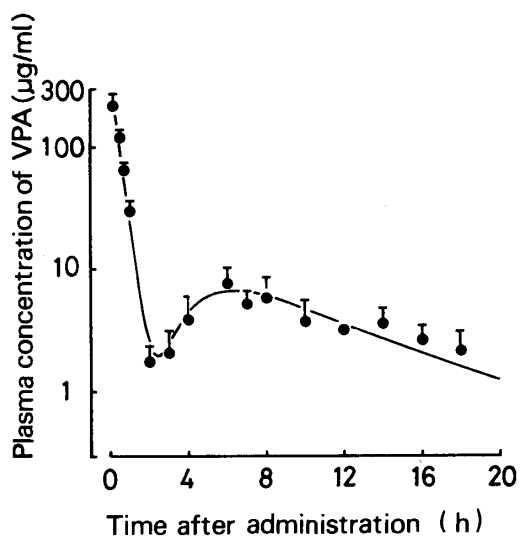

Fig. 4. Plasma Concentration of Valproic Acid after Intravenous Administration in Intact Rats

The solid line represents a simulation curve and each point represents a mean observed value with S.D.

Dose: VPA-Na 69.1 mg (VPA 60 mg)/kg.

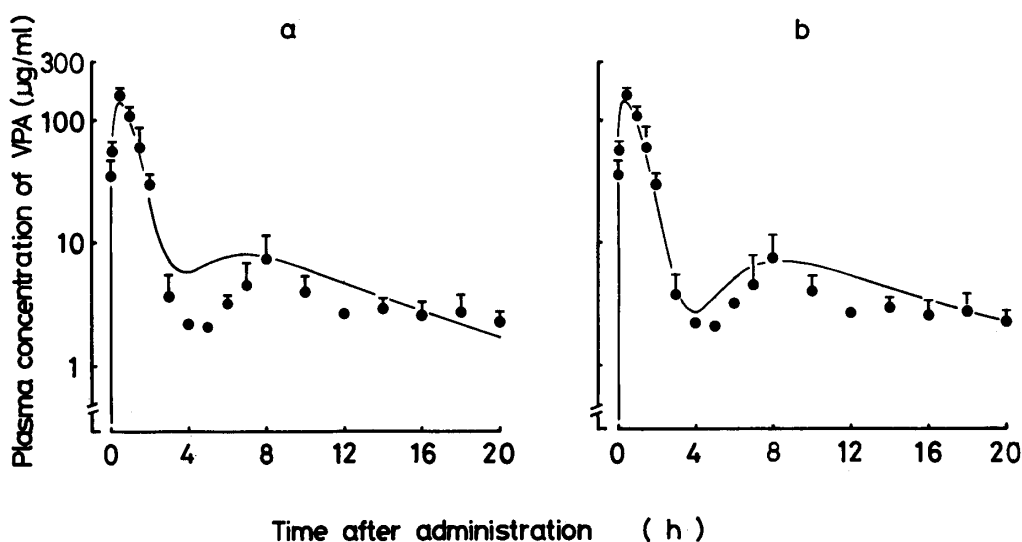

Fig. 5. Plasma Concentration of Valproic Acid after Oral Administration in Intact Rats

a) Segments of gut lumen  $n=4$ , b)  $n=5$ .

The solid line represents a simulated curve and each point represents a mean observed value with S.D.

Dose: VPA-Na 92 mg (VPA 80 mg)/kg.

Since the amount of drug that appeared in the plasma within 2 h based on enterohepatic circulation was evidently small (a negligible amount,  $0.43 \mu\text{g/ml}$ , at 1 h and no detectable amount within 50 min) as shown in the experiment with bile duct-linked rats (Fig. 2c), the effect of the circulation on the initial plasma levels after oral administration may be neglected. The model shown in Fig. 1c, excluding the effect of enterohepatic circulation, was adapted to the observed data at the initial time stage after oral administration in intact rats. The parameters,  $k_e$ ,  $k_s$  and  $V_d$ , were fixed at the values listed in Table I. Least-squares fit values of  $k_{apo}$  and  $F$  obtained are shown in Table I. The simulation curve with the model ( $n=4$ ) and the observed values are shown in Fig. 5a. The agreement is poor. The calculated curve rises far above the experimental data points at 4–6 h. The plasma levels of VPA after oral dosing to intact rats were also simulated with the model shown in Fig. 1b using various  $n$  values ( $n=2$ –8). However, the secondary peak of the simulation curve appeared much earlier than was actually observed when the  $n$  value was more than 5, while the secondary peak was flattened

and the trough in front of the secondary peak was much smaller at  $n < 4$ . Therefore, it was considered that the secondary increase in drug concentration after oral administration would be later than that in the case of i.v. dosing. When the number of segments of the gut lumen was increased from 4 to 5 with the other parameters listed in Table I, approximate agreement was obtained as shown in Fig. 5b, but when the  $n$  value was more than 6, the secondary peak of the simulation curve became later than the observed peak.

### Discussion

It is generally accepted that VPA is subject to enterohepatic circulation. The pharmacokinetics of VPA has been analyzed in terms of a two-compartment model in animals.<sup>7)</sup> In rats, however, rapid elimination and a secondary increase in drug concentration were observed (Fig. 4). The pharmacokinetics of VPA in rats therefore could not be analyzed in terms of a simple two-compartment model. The inadequacy of a simple two-compartment model is attributable to the late attainment of steady-state plasma levels as a result of the enterohepatic circulation. The absorption of VPA was extremely rapid; the  $t_{\max}$  after oral dosing was about 30 min, as shown in Fig. 5. Consequently, the drug may be rapidly transferred to the bile and quickly excreted into the duodenum (Fig. 2b), but the appearance of VPA in blood after reabsorption is relatively late (Fig. 2c), since the hydrolysis process may be the rate-limiting step in VPA disposition and the conjugated drug in bile excreted into duodenum may be subject to slow hydrolysis during the transfer in the gut lumen. It was observed that the elimination of plasma VPA in bile-exteriorized rats after i.v. administration was followed by a first-order process, and VPA was not detected in the plasma at 2 h and after (Fig. 2a). Thus, it was demonstrated that the secondary increase and prolonged maintenance of plasma VPA levels in intact rats was wholly due to the enterohepatic circulation. Additional evidence was obtained from the experiment of bile duct-linked rats. The plasma concentrations of VPA in acceptor rats (Fig. 2c), attributed to reabsorption of VPA in bile, were roughly consistent with the secondary increase of plasma levels of VPA in intact rats (Fig. 4). On the basis of these results, we developed a multicompartment model consisting of the central, bile and intestinal compartments with  $n$  segments ( $n=4$ ) to describe the plasma concentrations of VPA after i.v. dosing (Fig. 1a). Koizumi *et al.* proposed a compartment model with  $n$  segments of the gut lumen to describe the pharmacokinetics of an analgesic, and showed that the model is able to simulate the time course of the drug (including enterohepatic circulation) in the blood.<sup>5)</sup> Since enterohepatic circulation is a periodic process, inclusion of  $n$  segments of gut lumen in the present model is reasonable to describe the relatively slow absorption of VPA after hydrolysis. The plasma levels of VPA could be well fitted by this model (Fig. 4).

If the VPA conjugate in blood is not subject to hydrolysis, the reabsorption ratio of VPA (with respect to the amount excreted in bile), calculated by the method of Tse *et al.*,<sup>8)</sup> is approximately 62%. Assuming that the free VPA (16%) in bile is completely absorbed, at least 55% of VPA conjugates excreted in bile is reabsorbed after hydrolysis. Thus, the reabsorption of VPA based on enterohepatic circulation must depend markedly on the hydrolysis process. The VPA conjugate excreted in bile would reside for a relatively long time in the gut lumen, in proportion to the amount. It was shown that in rats the major metabolite of VPA is the glucuronide biosynthesized in the liver.<sup>1)</sup> This suggests that the hepatic first-pass effect of VPA is extensive in rats. Therefore, the amount of the conjugate after oral administration might be relatively more than that in the case of i.v. dosing, and the residence time of glucuronide in the gut lumen after oral dosing should be much longer than that after i.v. administration. Thus, the model to describe the plasma levels of VPA after oral administration should require more segments of gut lumen than that ( $n=4$ ) in the case of i.v. dosing. Indeed, the model with 5 segments was able to simulate approximately the time course of the drug in plasma following

oral administration. The simulation curve calculated by means of this model ( $n=5$ ), using the parameters listed in Table I, did not agree wholly with the observed values. This partial discrepancy may be due to involvement of other factors, such as the increase in excretion of VPA conjugate into feces.

In conclusion, the multicompartiment model presented in this paper is able to describe the time course of the plasma VPA level following i.v. and oral administrations in rats much better than the classical two-compartment model. The secondary peak and slower decline of plasma concentrations of VPA suggest the importance of enterohepatic recirculation in the disposition of the drug.

#### References

- 1) R. G. Dickinson, R. C. Harland, A. M. Ilias, R. M. Rodgers, S. N. Kaufman, R. K. Lynn, and N. Gerber, *J. Pharmacol. Exp. Ther.*, **211**, 583 (1979).
- 2) J. Simiand, P. Eymard, B. Ferrandes, and M. Polverelli, *Ann. Pharm. Fr.*, **31**, 205 (1973).
- 3) C. H. Lawyer, N. Gerber, R. K. Lynn, and R. G. Dickinson, *Res. Commun. Chem. Pathol. Pharmacol.*, **27**, 469 (1980).
- 4) T. B. Vree, E. van der Kleijn, and H. J. Knop, *J. Chromatogr.*, **121**, 150 (1976).
- 5) T. Koizumi, M. Kakemi, K. Katayama, and M. Ogawa, *J. Pharmacobio-Dyn.*, **4**, 461 (1981).
- 6) K. Yamaoka and T. Nakagawa, *J. Pharmacobio-Dyn.*, **6**, 596 (1983).
- 7) W. Löscher and H. Esenwein, *Arzneim-Forsch.*, **28**, 782 (1978).
- 8) F. L. S. Tse, F. Ballard, and J. Skinn, *J. Pharmacokin. Biopharm.*, **10**, 455 (1982).