

Pharmacokinetics of Glycyrrhetic Acid, a Major Metabolite of Glycyrrhizin, in Rats

Shiro ISHIDA,*^a Yoko SAKIYA,^a Tsutomu ICHIKAWA,^a and Shoji AWAZU^b

Faculty of Pharmaceutical Sciences, Tokushima Bunri University,^a Yamashiro-cho, Tokushima 770, Japan and Department of Biopharmaceutics, Tokyo College of Pharmacy,^b 1432-1 Horinouchi, Hachioji, Tokyo 192-03, Japan. Received May 1, 1989

The pharmacokinetics of glycyrrhetic acid (GLA) was examined in rats after bolus i.v. injection at a dose of 2, 5, or 12 mg/kg. The decline in plasma concentration was generally biexponential at each dose, but the terminal disposition became much slower with increase of dose. A greater than proportional increase in plasma GLA concentration was observed with increase of dose, suggesting a dose-dependency of GLA disposition. Apparent total body clearance decreased significantly with increase of dose. On the other hand, the apparent steady-state distribution volume after i.v. administration was unaffected by dose. The plasma disposition at each dose fitted well to a two-compartment pharmacokinetic model with Michaelis–Menten elimination. It was concluded that the pharmacokinetics of GLA in the rat is dose-dependent owing to a saturable elimination rate. The plasma level of GLA after glycyrrhizin (GLZ) i.v. dosing (100 mg/kg) in the control rats (without biliary fistulization) sustained the concentration range of 1.5–3 µg/ml during 1–48 h, but that in the rats with biliary fistulization declined with time. It was suggested that the sustained plasma level of GLA is accounted for by the intestinal reabsorption of GLA produced from GLZ and GLA-conjugates during the enterohepatic recycling of both.

Keywords glycyrrhetic acid; pharmacokinetics; dose-dependency; saturable elimination; tissue distribution

Glycyrrhetic acid (GLA), the aglycone of glycyrrhizin (GLZ), has many therapeutic effects, e.g., anti-ulcer,¹⁾ anti-inflammatory,^{2–4)} anti-hepatotoxic,^{5–7)} interferon-inducing,^{8,9)} and anti-tumor¹⁰⁾ actions. GLA has been used in the treatment of Addison's disease,¹¹⁾ essential hypotension,¹²⁾ and neurodermatitis.³⁾ However, GLA has been reported to produce the adverse effect of aldosteronism owing to its aldosterone-like effect,¹³⁾ potentiating effect on the action of aldosterone,¹⁴⁾ and inhibiting effect on aldosterone metabolism.^{15,16)} GLA is produced from GLZ by hydrolysis after administration of GLZ to humans,^{17–19)} rats,^{20–23)} and rabbits.²⁴⁾ GLZ has frequently been used in the treatment of chronic hepatitis²⁵⁾ and allergosis,²⁶⁾ but it also exhibits pseudo-aldosteronism.²⁷⁾ Oketani *et al.*¹⁹⁾ reported that GLA is effective against chronic hepatitis, because only GLA is detected in human serum when GLZ is orally administered. It is desirable, therefore, to elucidate the pharmacokinetic behavior of GLA in the body in order to use it and GLZ safely in clinical therapeutics. We previously reported the biliary excretion and enterohepatic cycling of GLZ in rats.²⁸⁾ However, no data on the pharmacokinetic characteristics of GLA have been reported so far.

In the present study, we examined the pharmacokinetics of GLA in rats by means of measurements of the plasma disposition after a bolus 2, 5, or 12 mg/kg i.v. dose and determined the tissue-to-plasma partition coefficients (K_p) at a steady-state plasma concentration. The plasma disposition of GLA after a 100 mg/kg i.v. dose of GLZ in rats was also examined.

Experimental

Materials Sodium glycyrrhetinate (GLA-Na) and GLZ were kindly supplied by Minophagen Pharmaceutical Co. (Tokyo, Japan). All other reagents were commercial products of analytical grade.

Animals Male Wistar rats (weighing 240–260 g) that had been fasted for 20 to 24 h prior to the experiments were used. Under light ether anesthesia, the right femoral artery was cannulated with PE-50 polyethylene tubing to collect blood samples in rats with and without biliary fistulization. A bile fistula was cannulated with PE-10 polyethylene tubing. The cannulated rats were kept in restraining cages with free access to water under normal housing conditions prior to the experiments. The rats

were allowed to recover from anesthesia prior to the injection of the drug (approximately 1 h). For K_p determination, the right femoral vein and thoracic duct were cannulated with PE-10 polyethylene tubing to infuse GLA and to collect lymph, respectively. The body temperature was kept at 37°C throughout the experiments by using a heat lamp.

Plasma Disposition GLA or GLZ was dissolved in 5% glucose solution. GLA (2, 5, or 12 mg/kg) and GLZ (100 mg/kg) (~1.0 ml each) were injected into the left femoral vein of the control rats (without biliary fistulization) and the control and bile duct-cannulated rats, respectively. After a bolus injection of 2 mg/kg GLA, blood samples (0.3 ml each) were collected from the cannula in heparinized polyethylene centrifuge tubes at 1, 3, 5, 10, 15, 20, and 30 min. In the cases of 5 and 12 mg/kg, blood samples were taken at 1, 5, 10, 20, 30, and 60 min. In the latter case, further samples were taken at 90 and 120 min. After a bolus injection of 100 mg/kg GLZ, blood samples (0.5 ml, each) were collected at 0.5, 1, 3, 5, 7, 9, 12, 20, 24, 28, 32, 36, 44, and 48 h. Rats after GLZ dosing were given fresh blood (2.0 ml), obtained from other rats, through the right femoral artery cannula immediately after each sampling at 5, 20, and 36 h. Plasma was separated by centrifugation for 5 min, and stored at –20°C until analysis.

Determination of Plasma-to-Blood Concentration Ratio (C_p/C_b) Fresh blood was collected *via* the carotid artery at 40 min after an i.v. injection of heparin. After incubation of the blood sample (1.0 ml) for 5 min at 37°C, 0.02 ml of solution containing 0.7–100 µg of GLA-Na in 5% glucose was added and the mixture was incubated for 30 min at 37°C. Aliquots (0.3 ml) of the sample solution were centrifuged for 5 min to obtain plasma.

Determination of Tissue-to-Plasma Partition Coefficient (K_p) at a Steady-State Plasma Level (C_{ss}) After a loading dose of 5 mg/kg GLA, the drug was infused through the cannula at the rate of 0.224 mg/kg/min for 60 min with a constant-rate infusion pump (model KN-201, Natsume Seisakusho Co. Ltd., Tokyo, Japan). The C_{ss} (ca. 55 µg/ml) was obtained within 20 min after the beginning of the infusion. Lymph was collected from 30 min to 60 min after the initiation of infusion through the thoracic duct cannula. Thereafter, a blood sample was immediately collected, then the rats were exsanguinated *via* a carotid artery, and perfused *in situ* with cold physiological saline *via* the venous trunk just inferior to the renal veins and portal vein until the effusate become colorless. The brain, lung, heart, liver, stomach, small intestine, kidney, muscle, skin, spleen, pancreas, and adipose tissue were quickly excised, rinsed well with cold physiological saline, blotted, and weighed. All the samples were stored at –20°C until required. All wet tissues were assumed to have a density of 1.0. Each tissue sample was homogenized with two volumes of physiological saline in an ice bath before analysis.

Sample Analysis Samples of 0.1 ml of blood, plasma, and lymph, and 0.3–0.6 ml of homogenate were used for the GLA determination. For the determination of GLA and GLZ after GLZ dosing, samples of 0.2 ml of plasma were used. The methods of determination of both GLA²⁹⁾ and GLZ³⁰⁾ were the same as those described previously, *i.e.*, the drugs were determined by HPLC after extraction with MeOH.

Data Analysis The area under the plasma concentration time curve

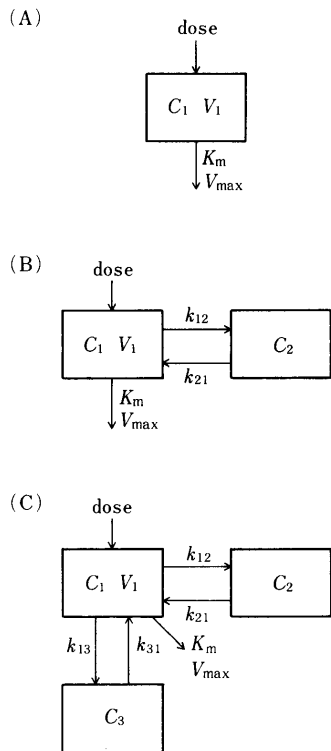

Fig. 1. One- (A), Two- (B), and Three- (C) Compartment Pharmacokinetic Model with Michaelis-Menten Elimination from the Central Compartment

For the parameters in each model, see the text.

(AUC) and the mean residence time (MRT) were calculated by trapezoidal integration with extrapolation to infinite time.³¹⁾ The steady-state distribution volume ($V_{d_{ss}}$) and the total body clearance (CL_{tot}) were calculated from $dose \cdot MRT/AUC$ and $dose/AUC$, respectively. The plasma concentration data were fitted to differential mass balance equations for a one-, two-, or three-compartment pharmacokinetic model with Michaelis-Menten elimination from the central compartment (Fig. 1). The differential mass balance equations for each model are expressed as follows.

$$dC_1/dt = -V_{max} \cdot C_1 / (K_m + C_1) \quad (\text{Fig. 1A})$$

$$dC_1/dt = -(k_{12} + V_{max}/(K_m + C_1))C_1 + k_{12} \cdot C_2 \quad (\text{Fig. 1B})$$

$$dC_2/dt = k_{21} \cdot C_1 - k_{21} \cdot C_2$$

$$dC_1/dt = -(k_{12} + k_{13} + V_{max}/(K_m + C_1))C_1 + k_{12} \cdot C_2 + k_{21} \cdot C_3 \quad (\text{Fig. 1C})$$

$$dC_2/dt = k_{21} \cdot C_1 - k_{21} \cdot C_2$$

$$dC_3/dt = k_{31} \cdot C_1 - k_{31} \cdot C_3$$

The initial conditions are as follows:

$$C_1(0) = D/V_1, \quad C_2(0) = 0, \quad C_3(0) = 0$$

where C_1 is GLA concentration in the central compartment, C_2 and C_3 are GLA concentrations in the peripheral compartments, k_{12} and k_{13} are the first-order partition rate constants out of the central compartment, and k_{21} and k_{31} are the first-order partition rate constants back into the central compartment. V_1 is the volume of distribution of the central compartment. V_{max} and K_m are the maximum velocity and the Michaelis constant, respectively. D is the amount of the dose. The fitting was performed by using the Multi-Runge program.³²⁾ Data were weighted with the reciprocals of the plasma concentrations. The apparent K_p value of liver was corrected according to Eq. 1 by the method of Chen and Gross³³⁾:

$$K_p = \left(\frac{Q_H + CL_{int,H} \cdot f_p}{Q_H} \right) \frac{C_H}{C_{ss}} \quad (1)$$

where Q , CL_{int} , C , and f_p represent the plasma flow rate, metabolic intrinsic clearance, GLA concentration, and plasma unbound fraction, respectively, and H denotes the liver. Q_H (8.3 ml/min) was taken from the literature.³⁴⁾ The term $CL_{int,H} \cdot f_p$ was calculated by using Eq. 2.

$$CL_{tot}^{ss} = \frac{Q_H \cdot CL_{int,H} \cdot f_p}{Q_H + CL_{int,H} \cdot f_p} \quad (2)$$

where CL_{tot}^{ss} is total body clearance at C_{ss} , which is the value obtained by dividing the constant infusion rate by C_{ss} .

Statistical Analysis Akaike's information criterion (AIC)³⁵⁾ was used to decide the model that provided the best fit of the plasma concentration versus time curve after i.v. dosing. All means are presented with their standard error (mean \pm S.E.). Statistical analysis was performed by the use of Student's t test with $p=0.05$ as the minimal level of significance.

Results

Plasma Disposition The plasma disposition of GLA after 2, 5, or 12 mg/kg i.v. administration in rats is plotted in Fig. 2. The decline in plasma concentration was generally biexponential at each dose, but the terminal disposition became much slower with increase of the dose. As shown in Table I, a greater than proportional increase in AUC with increase of the dose was observed. This suggests dose-dependency of GLA disposition. Therefore, CL_{tot} and $V_{d_{ss}}$ were represented as apparent values (Table I). The MRT and apparent CL_{tot} values increased and decreased significantly with increase of the dose, respectively ($p < 0.05$). On the other hand, the apparent $V_{d_{ss}}$ value was unaffected by dose. The plasma data at each dose were fitted to a one-, two-, or three-compartment pharmacokinetic model with

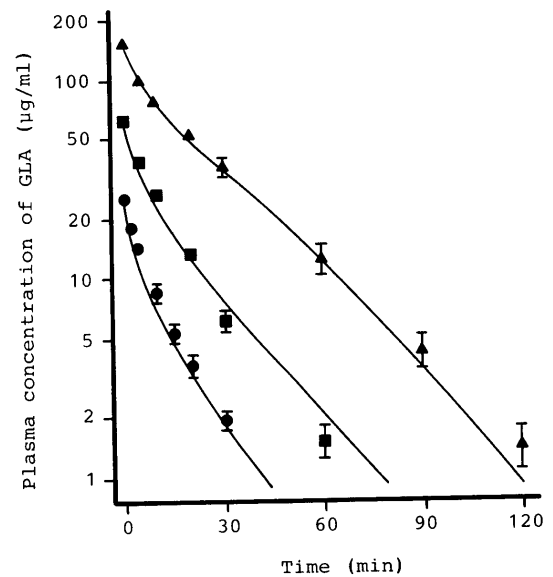

Fig. 2. Plasma Disappearance Curves of GLA after 2 (●), 5 (■), or 12 (▲) mg/kg i.v. Administration in Rats

Each point represents the mean \pm S.E. of four rats. The data points without a vertical bar include the S.E. within the point. Lines were calculated by fitting to the equation for Fig. 1B using the Multi-Runge program.³³⁾ For details, see the text.

TABLE I. Pharmacokinetic Parameters of GLA in Rats^{a)}

Parameter	2 mg/kg	5 mg/kg	12 mg/kg
AUC ^{b)} (min · mg/ml)	0.247 \pm 0.019	0.833 \pm 0.038	3.283 \pm 0.200
MRT ^{c)} (min)	12.031 \pm 0.735	15.561 \pm 0.679 ^{f)}	26.296 \pm 2.377 ^{g)}
$V_{d_{ss}}$ ^{d)} (ml/kg)	98.494 \pm 7.565	93.610 \pm 2.469	95.665 \pm 3.486
CL_{tot} ^{e)} (ml/min/kg)	8.194 \pm 0.562	6.047 \pm 0.276 ^{f)}	3.694 \pm 0.214 ^{g)}

a) Results are given as the mean \pm S.E. of four rats. b) and c) The area under the plasma concentration curve and the mean residence time, respectively. d) and e) Apparent values of the steady-state distribution volume and total body clearance, respectively. f) Significant difference ($p < 0.05$) from 2 mg/kg. g) Significant difference ($p < 0.05$) from 2 and 5 mg/kg. For details of the calculations, see the text.

Michaelis-Menten elimination from the central compartment (Fig. 1). The two-compartment model (Fig. 1B) showed the best fit to the plasma concentration data (Fig. 2). The AIC value was also smaller for the two-compartment model than for the other models (the AIC values were 78.7, 32.9, and 110.2 in the one-, two-, and three-compartment models, respectively). The pharmacokinetic parameters for the best-fit two-compartment model are listed in Table II.

Thus, it was found that GLA disposition is dose-dependent owing to saturable elimination.

Plasma Disposition of GLA Following GLZ i.v. Dosing The plasma concentrations of GLA and GLZ after 100 mg/kg i.v. administration of GLZ in rats with and without biliary fistulization are plotted in Fig. 3. As reported,²⁰⁻²³ GLA produced from GLZ was observed in plasma. In the control rats, the high plasma level of GLA at

TABLE II. Pharmacokinetic Parameters of GLA Estimated Based on the Two-Compartment Model with Michaelis-Menten Elimination in Rats

k_{12} (min^{-1})	0.0797 ± 0.0113
k_{21} (min^{-1})	0.0817 ± 0.0113
K_m ($\mu\text{g/ml}$)	27.971 ± 5.704
V_{\max} ($\mu\text{g/ml/min/kg}$)	15.329 ± 1.751
V_1 (ml/kg)	72.293 ± 2.539

For details of the calculation of parameters (\pm computer-calculated S.D.), see the text.

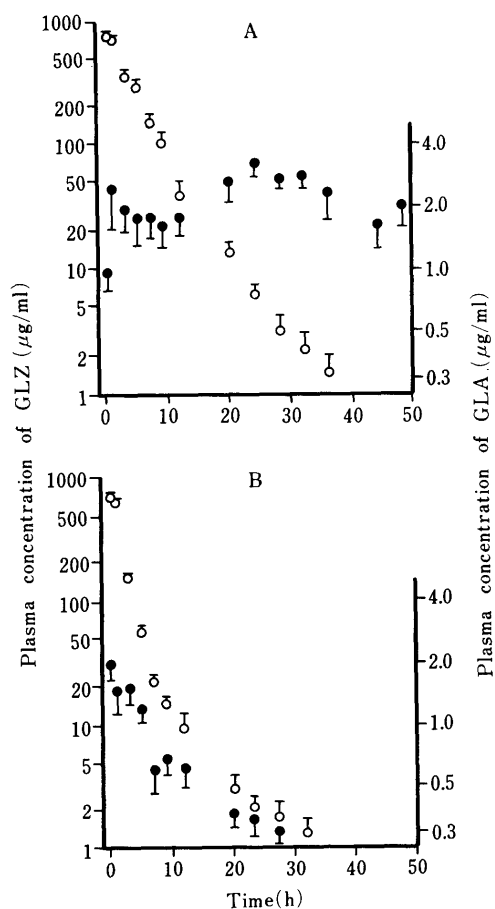

Fig. 3. Plasma Concentrations of GLA (●) and GLZ (○) after 100 mg/kg i.v. Administration of GLZ in Rats

A, the control rats (without biliary fistulization); B, the bile duct-cannulated rats. Each point represents the mean \pm S.E. of four to eight rats.

1 h declined gradually with decrease of GLZ plasma level until 9 h. Thereafter, the GLA level tended to increase until 24 h, and the high level at 24 h was sustained in the concentration range of 1.5–3.0 $\mu\text{g/ml}$ until the last sampling time, 48 h (Fig. 3A). In the bile duct-cannulated rats, the GLA level tended to decrease with decrease of GLZ plasma level and was no longer detectable (the limit of detection is 0.125 $\mu\text{g/ml}$ ²⁹) after 28 h (Fig. 3B). The overall concentration of GLA in both groups was lower than 4 $\mu\text{g/ml}$.

Plasma-to-Blood Concentration Ratio (C_p/C_B) As shown in Fig. 4, the C_p/C_B values were almost constant (1.787 ± 0.019 , $n=12$) over the range of plasma concentrations (2–150 $\mu\text{g/ml}$) studied. The hematocrit value was 0.454 in this study. This indicates that GLA is not well taken up into erythrocytes.

Tissue-to-Plasma Partition Coefficient (K_p) at Steady-State Plasma Level (C_{ss}) The K_p values and the tissue distribution volumes ($K_p \cdot V_T$) are listed in Table III. All the K_p values were less than 1.0, indicating poor tissue distribution of GLA. The sum of the total tissue distribution volume ($\sum K_p \cdot V_T$) and plasma volume³⁴) is 25.424 ml/250 g, which corresponds well to the apparent Vd_{ss} value at 2, 5, or 12 mg/kg dose (Table I). This suggests a little distribution to

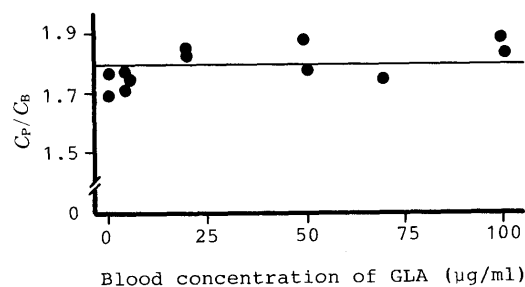

Fig. 4. Plasma-to-Blood Concentration Ratios (C_p/C_B) of GLA in Rats Determined *in Vitro* at 37°C

The points represent the experimental values. The line shows the mean value (1.787).

TABLE III. Tissue-to-Plasma Partition Coefficients (K_p) and Tissue Distribution Volume ($K_p \cdot V_T$) at Steady-State Plasma Concentration (C_{ss})^a of GLA in Rats

Tissue	K_p ^b	$K_p \cdot V_T$ (ml)	V_T ^c (ml)
Brain	0.019 ± 0.003	0.036	1.9 ^d
Lung	0.042 ± 0.006	0.055	1.3 ^d
Heart	0.086 ± 0.013	0.086	1.0 ^d
Liver	0.078 ± 0.005	0.780	10.0 ^d
Kidney	0.121 ± 0.012	0.266	2.2 ^d
Stomach	0.071 ± 0.002	0.092	1.3 ^d
Small intestine	0.056 ± 0.012	0.773	13.8 ^e
Pancreas	0.047 ± 0.002	0.038	0.8 ^d
Spleen	0.053 ± 0.017	0.027	0.5 ^d
Muscle	0.059 ± 0.001	7.375	125.0 ^e
Skin	0.089 ± 0.006	3.978	44.7 ^f
Adipose tissue	0.041 ± 0.007	0.718	17.5 ^g
Plasma	1.000	11.200	11.2 ^e
Lymph	0.293 ± 0.058		
Total		25.424	231.6

a) C_{ss} ($55.26 \pm 5.31 \mu\text{g/ml}$) was obtained by the constant infusion of GLA at the rate of 0.224 mg/kg/min. b) Results are given as the mean \pm S.E. of three rats. The apparent K_p value of liver was corrected according to the method of Chen and Gross.³³ c) Tissue volume was based on a 250 g rat. d) Determined experimentally from the wet tissue weight by assuming a density of 1.0. e) Reference 34. f) Reference 36. g) Reference 37.

lymph, though the K_p value of lymph was higher than those of other tissues. This might be related to the anti-inflammatory effect of GLA.²⁻⁴⁾ The sum of $K_p \cdot V_T$ values of skin and muscle was about 80% of $\sum K_p \cdot V_T$, indicating that almost all GLA is distributed to skin and muscle.

Discussion

The plasma concentration *versus* time curves at each i.v. dose showed the best fit to the two-compartment pharmacokinetic model (Fig. 1B). Subsequently, the relation between CL_{tot} and plasma concentration at low GLA plasma concentrations (0.1–25 $\mu\text{g/ml}$) was examined. The relation is expressed as follows:

$$CL_{tot} = \frac{v}{C_p} = \frac{V_{max} \cdot V_1}{K_m + C_p} \quad (3)$$

where C_p is plasma concentration of GLA. The elimination rate (v) is given by the following equation:

$$v = \frac{V_{max} \cdot V_1 \cdot C_p}{K_m + C_p} \quad (4)$$

As shown in Fig. 5, the CL_{tot} value was plasma concentration-dependent even at low concentration. Such a dependency might be observed in humans, as the human serum concentrations are ~ 0.65 and ~ 0.8 $\mu\text{g/ml}$ after GLZ i.v. (80 mg/man)^{17,18)} and oral (100–182 mg/man)¹⁷⁻¹⁹⁾ administrations, respectively. Parke *et al.*^{38,39)} reported that after an i.p. dose of ^3H -GLA (25 mg/kg) to rats, all the drug was excreted in the bile as three metabolites (sulfate, monoglucuronide, and diglucuronide conjugates). Previously, we reported that the biliary and urinary excretions of GLA after an i.v. dose (60 mg/kg) in rats were only 0.4 and 0.03% of the dose, respectively.²⁹⁾ This suggests that almost all GLA is metabolized. Therefore, the dose dependency of GLA disposition may be caused by a saturable metabolism in the clearing organ(s). Since sulfate^{40,41)} and glucuronide⁴²⁾ conjugations of drugs occur mainly in the liver, GLA may be exclusively metabolized in the liver. In this study, the liver was assumed to be the only eliminating tissue. Accordingly, the apparent K_p value of liver was corrected according to Eq. 1. As de-

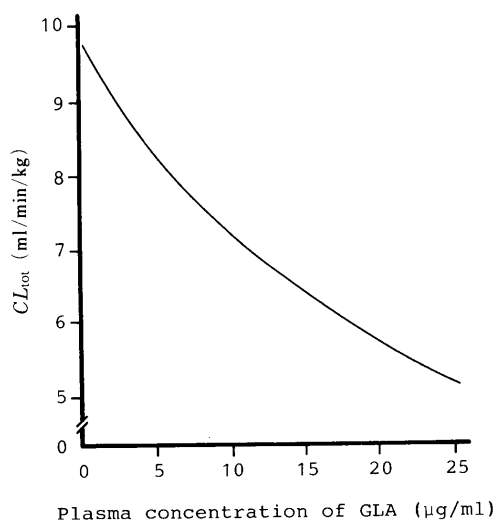

Fig. 5. Simulation Line for Total Body Clearance (CL_{tot}) *versus* Plasma Concentration of GLA

For details of the simulation, see the text.

scribed already, GLA is produced from GLZ after administration of GLZ to humans,¹⁷⁻¹⁹⁾ rats,²⁰⁻²³⁾ and rabbits.²⁴⁾ In this study, GLA was observed in plasma after an i.v. dose of GLZ (Fig. 3). Previously, we reported that $\sim 80\%$ of the dose of GLZ is excreted in the bile following i.v. administration of 100 mg/kg to rats and subsequently undergoes enterohepatic recycling.²⁸⁾ Hattori *et al.*⁴³⁾ reported that GLZ is also hydrolyzed to GLA by human intestinal flora. Such a hydrolysis may occur in rat intestine, but this was not examined in the present study. Parke *et al.*^{38,39)} also reported that three GLA-conjugates undergo hydrolysis in the intestine subsequent to their biliary excretion, and then enterohepatic recycling of GLA occurs in rats. The increase of GLA plasma level at 9 h and the sustained level from 9 to 48 h following GLZ i.v. administration (Fig. 3A) may be accounted for by the intestinal reabsorption of GLA produced from GLZ and GLA-conjugates during the enterohepatic recycling of both, because such behavior was not observed in the bile duct-cannulated rats after GLZ dosing, *i.e.*, the GLA plasma level declined with time (Fig. 3B).

The apparent Vd_{ss} value was small (approximately 2 times the plasma volume³⁴⁾) at each dose (Table I) and no uptake of GLA into erythrocytes was observed. These results may be caused by the small plasma unbound fraction (0.0076–0.0109) over the plasma concentration range of 2–150 $\mu\text{g/ml}$ studied. Plasma unbound fraction was calculated from the binding parameters reported previously.⁴⁴⁾

It has been reported that GLA plays a major role in the induction of pseudo-aldosteronism through the following mechanisms: (1) GLA binds to kidney aldosterone receptors,¹³⁾ (2) GLA potentiates aldosterone action¹⁴⁾ and (3) GLA inhibits aldosterone deactivating enzyme.^{15,16)} Actions (1) and (2) were not observed in the case of GLZ^{13,14)} and GLA is more potent than GLZ as regards action (3).¹⁶⁾ It seems that care may be required in the case of successive administrations of GLA and GLZ to humans, in view of the occurrence in the rat of saturable elimination at low plasma concentrations of GLA, which is the agent mainly responsible for the side-effects.

Acknowledgement This work was supported in part by a Grant-in-Aid from the Shimabara Science Promoting Foundation.

References and Notes

- 1) K. Takagi, S. Okabe and R. Saziki, *Jpn. J. Pharmacol.*, **19**, 418 (1969).
- 2) R. S. H. Finney and G. F. Somers, *J. Pharm. Pharmacol.*, **10**, 613 (1958).
- 3) E. Colin-Jones, *Postgrad. Med. J.*, **36**, 678 (1960).
- 4) K. K. Tangri, P. K. Seth, S. S. Parmar and K. P. Bhargava, *Biochem. Pharmacol.*, **14**, 1277 (1965).
- 5) Y. Kiso, M. Tohkin and H. Hikino, *Planta Medica*, **49**, 222 (1983).
- 6) Y. Kiso, M. Tohkin, H. Hikino, M. Hattori, T. Sakamoto and T. Namba, *Planta Medica*, **50**, 298 (1984).
- 7) H. Hikino, *Yakugaku Zasshi*, **105**, 109 (1985).
- 8) N. Abe, T. Ebina and N. Ishida, *Microbiol. Immunol.*, **26**, 535 (1982).
- 9) N. Ishida, "Symposium on Liver and Glycyrrhizin," Minophagen Pharmaceutical Co., Tokyo, 1983, pp. 120–124.
- 10) H. Nishino, K. Kitagawa and A. Iwashima, *Carcinogenesis*, **5**, 1529 (1984).
- 11) H. E. Pelsler, A. F. Willebrands, M. Frenkel, R. M. van der Heide and J. Groen, *Metabol.*, **2**, 322 (1953).
- 12) K. Arakawa, *Minophagen Med. Rev.*, Suppl. **13**, 43 (1979).
- 13) A. Ulmann, J. Menard and P. Corvol, *Endocrinology*, **97**, 46 (1975).

- 14) S. Ishikawa and T. Saito, *Endocrinol. Jpn.*, **27**, 697 (1980).
- 15) L. M. Atherden, *J. Biol. Chem.*, **69**, 75 (1958).
- 16) Y. Tamura, T. Nishikawa, K. Yamada, M. Yamamoto and A. Kumagai, *Arzneim.-Forsch.*, **29**, 647 (1979).
- 17) N. Nakano, H. Kata, H. Suzuki, K. Nakao, S. Yano and M. Kanaoka, *Proc. Symp. WAKAN-YAKU*, **14**, 97 (1981).
- 18) S. Yano and N. Nakano, *Biomedicine & Therapeutics*, **7**, 703 (1981).
- 19) Y. Oketani, I. Takehara, H. Mikuni, T. Shiraishi, K. Wakamatsu, H. Watanabe and T. Tanaka, *The Clinical Report*, **19**, 197 (1985).
- 20) K. Yasuda, T. Shibuya, M. Nozaki, K. Tsurumi, H. Fujimura and F. Kaneuchi, *Yakugaku Zasshi*, **98**, 1545 (1978).
- 21) K. Terasawa, M. Bandoh, H. Tosa and J. Hirate, *J. Pharmacobio-Dyn.*, **9**, 95 (1986).
- 22) K. Terasawa, M. Bandoh, H. Tosa, K. Torizuka and J. Hirate, *J. Med. Pharm. Soc. WAKAN-YAKU*, **3**, 105 (1986).
- 23) M. Nozaki, K. Tsurumi and H. Fujimura, *Yakugaku Zasshi*, **90**, 693 (1970).
- 24) T. Taguchi, *Seikagaku*, **40**, 817 (1968).
- 25) K. Hino, T. Miyakawa, T. Miyahara, S. Fujikura, M. Iwasaki and K. Takahashi, *Minophagen Med. Rev.*, **26**, 270 (1981).
- 26) S. Sotomatsu, Y. Takaishi, J. Hiroi, A. Namikata and N. Okano, *Skin and Urology*, **21**, 138 (1959).
- 27) H. Shio, *Clin. Endocrinol.*, **30**, 57 (1982).
- 28) T. Ichikawa, S. Ishida, Y. Sakiya, Y. Sawada and M. Hanano, *J. Pharm. Sci.*, **75**, 672 (1986).
- 29) T. Ichikawa, S. Ishida, Y. Sakiya and Y. Akada, *Chem. Pharm. Bull.*, **32**, 3734 (1984).
- 30) T. Ichikawa, S. Ishida, Y. Sakiya and Y. Sawada, *Chem. Pharm. Bull.*, **33**, 3031 (1985).
- 31) K. Yamaoka, T. Nakagawa and T. Uno, *J. Pharmacokinet. Biopharm.*, **6**, 165 (1978).
- 32) K. Yamaoka and T. Nakagawa, *J. Pharmacobio-Dyn.*, **6**, 595 (1983).
- 33) H. S. G. Chen and J. F. Gross, *J. Pharmacokinet. Biopharm.*, **7**, 117 (1979).
- 34) K. B. Bischoff, R. L. Dedrick, D. S. Zaharko and J. A. Longestret, *J. Pharm. Sci.*, **60**, 1128 (1971).
- 35) H. Akaike, *IEEE Trans. Autom. Control*, **19**, 716 (1974).
- 36) L. Jansky and J. S. Hart, *Can. J. Physiol. Pharmacol.*, **46**, 653 (1968).
- 37) R. J. Lutz, R. L. Dedrick, H. B. Matthews, T. E. Eling and M. W. Anderson, *Drug Metab. Disp.*, **5**, 386 (1977).
- 38) D. V. Parke, S. Pollock and R. T. Williams, *J. Pharm. Pharmacol.*, **15**, 500 (1963).
- 39) D. V. Parke, "Symposium on Carbenoxolon Sodium," ed. by J. Robson and F. Sullivan, Butterworth Scientific Publications, London, 1968, pp. 15—24.
- 40) P. W. Robbins and F. Lipmann, *J. Biol. Chem.*, **229**, 837 (1957).
- 41) Y. Nose and F. Lipmann, *J. Biol. Chem.*, **233**, 1348 (1958).
- 42) G. J. Dutton and I. D. E. Storey, *Biochem. J.*, **57**, 275 (1954).
- 43) M. Hattori, T. Sakamoto, K. Kobayashi and T. Namba, *Planta Medica*, **48**, 38 (1983).
- 44) S. Ishida, T. Ichikawa and Y. Sakiya, *Chem. Pharm. Bull.*, **36**, 440 (1988).