

Haemoglobin Model Compound Having Conformationally Linked Haems¹

By TEDDY G. TRAYLOR,* YOSHITAKA TATSUNO, DENNIS W. POWELL, and JOHN B. CANNON
(Department of Chemistry, University of California, San Diego, La Jolla, California 92093)

Summary A dihaem compound has been synthesized from *meso*-1,2-di(3-pyridyl)ethylene diamine and mesoporphyrin monomethyl ester; this compound shows two distinct rates of carbon monoxide binding indicating some haem-haem interaction.

Co-OPERATIVITY in haemoglobin ligation with oxygen or carbon monoxide is thought to result from the four haems being an integral part of the same conformational system.² In order to study the interaction of haems within a single conformational system, we have synthesized the haem

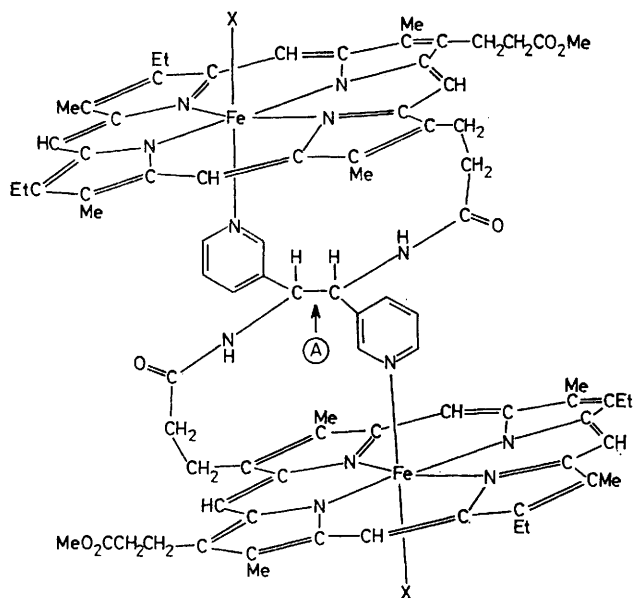

(1)

- a; Without ligand X
 b; X = O₂
 c; X = CO

(1a)† This compound, being derived from *meso*-1,2-di(3-pyridyl)ethylenediamine, has a centre of symmetry. However, in the five co-ordinate form shown, the two haems are conformationally linked, having the central ethylene linkage in common as in, *e.g.*, decalin. Any change in the upper iron-containing ring conformation should rotate the ring about this bond and this rotation must affect the conformation of the lower (identical) ring.

Compound (1a) reversibly binds oxygen in solution to give (1b) as do similar monohaem compounds.³ However, unlike the monohaem model compounds,³ it reacts with carbon monoxide with two rate constants to give (1c). The kinetic constants determined by flash spectroscopy for the reactions in equations (1) and (2) are shown in the Table.

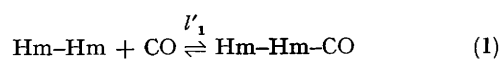

The fast rate, l'_1 , is similar to those of strained model haems³ and is about one-third that of the free four-co-ordinate haem, mesohaem dimethyl ester (3), and the slow rate, l'_2 , is very similar to that of the five-co-ordinate synthetic myoglobin sites^{3,4} as in mesohaem methyl 3-(3-pyridyl)propyl diester (2).

While the mechanism of this two-step reaction is not clear at present, a combination of base elimination⁵ mechanism (K_1 , l'_1) and association mechanism (l'_2), shown in the Scheme, seems likely.

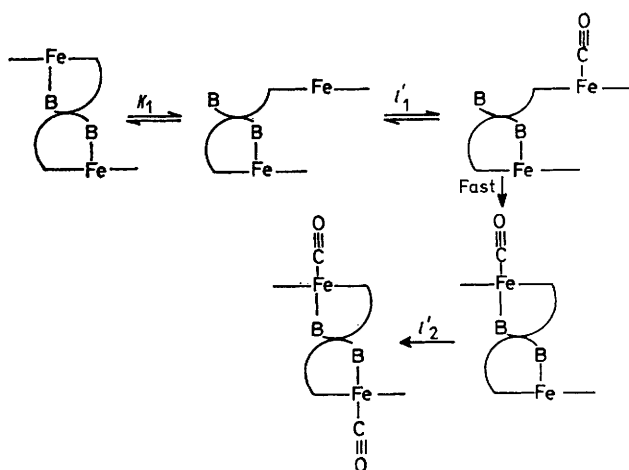

SCHEME

The observation that half oxidation of (1) results in the disappearance of the faster rate agrees with these postulates.

We have previously demonstrated⁵ the association mechanism for unstrained chelated haems like (2) (with $K_1 < 0.01$) and the base elimination mechanism for strained chelated haems (with steric hindrance in the side chain ring and $K_1 > 0.1$).³ It appears that the strain introduced into (1) by using a two-carbon³ rather than a three-carbon⁵ amine in the side chain and introducing the bicyclic structure resulted in shifting K_1 for (1a) so that one of the two

TABLE. Rate constants for reaction of haems with carbon monoxide.

Compound	Solvent	$l'_2/l \text{ mol}^{-1} \text{ s}^{-1}$	Pressure change/ Torr ⁻¹ s ⁻¹	$l'_1/l \text{ mol}^{-1} \text{ s}^{-1}$	Pressure change/ Torr ⁻¹ s ⁻¹	Ref.
(1a)	CTAB ^a	1.3×10^7	16	1×10^8 ^b	120	This work
(1a)	CH ₂ Cl ₂	6×10^6	70	4×10^7	500	This work
(2) ^c	CTAB ^a	1.0×10^7	13			4
(3) ^d	CTAB ^a	4×10^8	500			5

^a 2.5% cetyltrimethylammonium bromide in water containing 0.1 F potassium phosphate at pH 7.3. ^b Obtained by initial rate measurements. ^c Mesohaem methyl 3-(3-pyridyl)propyl diester. ^d Mesohaem dimethyl ester.

† *meso*-1,2-Di(3-pyridyl)ethylenediamine was prepared according to the literature (S. Trippett, *J. Chem. Soc.*, 1957, 4407) and coupled with mesoporphyrin monomethyl ester through the pivaloyl anhydride (J. Almog, J. E. Baldwin, R. L. Dyer, J. Huff, and C. J. Wilkerson, *J. Amer. Chem. Soc.*, 1974, **96**, 5600) as described elsewhere (ref. 3). Analyses, n.m.r. spectra, and molecular weight determinations agree with the structures assigned. Insertion of iron atom into the porphyrin (ref. 3) afforded the haemin chloride (1).

haems is partially in the four-co-ordinate, fast-reacting form at any one time. After this four-co-ordinate haem binds carbon monoxide and closes to a hexaco-ordinate form,⁵ a less strained conformer about the central C-C bond becomes available and the second step can proceed more slowly without base elimination.

On the basis of the dual mechanism, base elimination leads to faster reaction but poorer binding of carbon

monoxide than does the association mechanism.^{3,5} This suggests co-operative binding of carbon monoxide with (1), a possibility which is under investigation.

We are grateful to the National Institutes of Health for support.

(Received, 9th June 1977; Com. 565.)

¹ Presented at the Centennial Organic Chemistry Symposium of The American Chemical Society, New York, April 1976.

² F. Antonini and M. Brunori, 'Hemoglobin and Myoglobin and Their Reactions with Ligands,' North Holland, Amsterdam, 1971, p. 381; R. G. Shulman, J. J. Hopfield, and S. Ogawa, *Quart. Rev. Biophys.*, 1975, **326**, and references cited therein.

³ C. K. Chang and T. G. Traylor, *J. Amer. Chem. Soc.*, 1973, **95**, 5810; J. Geibel, J. Cannon, D. Campbell, and T. G. Traylor, *ibid.*, in the press; C. K. Chang and T. G. Traylor, *Proc. Nat. Acad. Sci. U.S.A.*, 1975, **72**, 1166.

⁴ J. Geibel, C. K. Chang, and T. G. Traylor, *J. Amer. Chem. Soc.*, 1975, **97**, 5924.

⁵ J. Cannon, J. Geibel, M. Whipple, and T. G. Traylor, *J. Amer. Chem. Soc.*, 1976, **98**, 3395.