

The Chemistry of Thioesters. Conversion into Monothioacetals, Ketones and Vinyl Sulphides[†]

By LAKSHMI NARASIMHAN, ROBERT SANITRA, and JOHN S. SWENTON
(Department of Chemistry, The Ohio State University, Columbus, Ohio 43210)

Summary The reaction of organolithium reagents with thioesters affords intermediates which can be converted into monothioacetals or vinyl sulphides.

THE reactions of organometallic reagents with aromatic and aliphatic thioketones,² dithioesters,² trithiocarbonates, thioketenes,³ and thioketene S-oxides⁴ often afford major products from addition to the thiocarbonyl sulphur atom, *i.e.*, thiophilic additions.² We have studied the reactions of the *O*-ethyl thioesters (1) with alkyl-lithiums and report: (i) that nucleophilic addition occurs at the thiocarbonyl carbon; (ii) the tetrahedral adducts (2) from the addition can be trapped with methyl iodide to give monothioacetals (3)⁵ in high yields; and (iii) warming the adducts (2) to room temperature in the presence of lithium di-isopropylamide (LDA) yields thioenolates with high regioselectivity.

TABLE 1. Formation and hydrolysis of monothioacetals^a

RC(:S)OEt	R'Li ^c	% Yield	
		RR'C(OEt)SMe ^{d,†}	R'C(:O)R
R ^b	R'		
Ph	Me	97	80
C ₆ H ₅ ^e	Bu ⁿ	90	75 ^g
C ₆ H ₅	Ph	82	80
C ₆ H ₁₁ ^h	Ph	92	79
C ₆ H ₁₁	Me	91	88 ^g
C ₆ H ₁₁	Bu ⁿ	85	70
X [†]	Me	—	85

^a In a typical procedure, methyl-lithium (21 mmol) was added dropwise to a solution of *O*-ethyl thiobenzoate (15 mmol) in THF (50 ml) at -78 °C. After 30 min, methyl iodide (21 mmol) was added. Workup afforded 2.82 g (97%) of the monothioacetal. All new compounds gave correct combustion analyses or exact molecular weights. ^b R corresponds to R¹R²CH in (1). ^c R'Li corresponds to R³CH₂Li in the Scheme. Addition of *t*-butyl-lithium to thioesters often leads to a mixture of products which will be discussed in our full manuscript. ^d Yield of monothioacetal after workup and molecular distillation. ^e C₆H₅ = cyclopropyl. ^f The monothioacetals should be handled in base-washed apparatus because of their sensitivity to acids. ^g Isolated and characterized as its 2,4-dinitrophenylhydrazone derivative. ^h C₆H₁₁ = cyclohexyl.

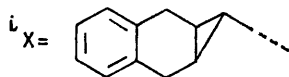

The reaction of the thioesters (1) at -78 °C in tetrahydrofuran with alkyl-lithiums followed by addition of methyl iodide gives the monothioacetals (3) as colourless liquids. The reaction appears quite general since both enolizable and nonenolizable substrates undergo the process in high yields (Table 1). The structure and purity of the monothioacetals (3) were confirmed in each case by ¹³C n.m.r. spectroscopy since the asymmetric centre often complicates the interpretation of the ¹H n.m.r. spectra of

the compounds. To establish that intermediates of structure (2) were formed in this reaction, the addition product from phenyl-lithium and *O*-ethyl thiobenzoate was allowed to warm to room temperature, resulting in the formation of thiobenzophenone (51% yield by u.v. analysis at 600 nm). The monothioacetals formed in these reactions were cleanly hydrolysed to ketones by chloramine-T⁶ in aqueous methanol at room temperature in <1 h. The resulting ketones were characterized by comparison of their spectra with those of standard samples and/or the m.p. of their 2,4-dinitrophenylhydrazone derivatives.

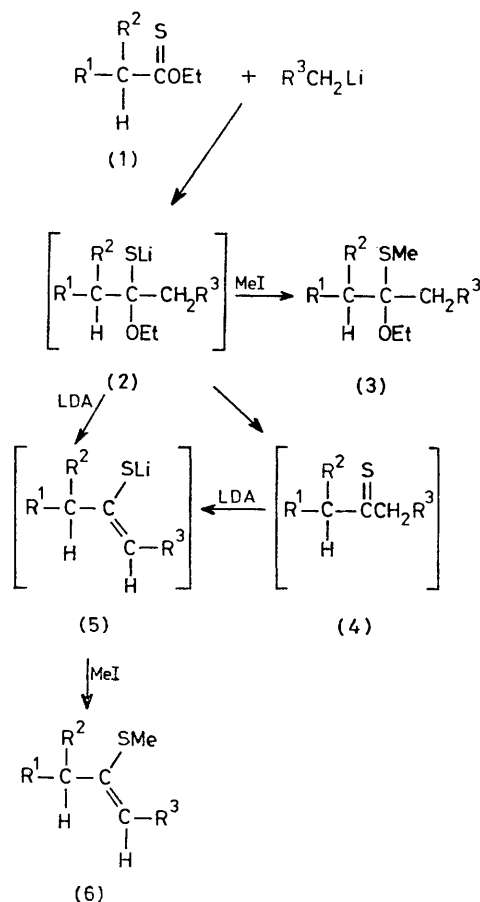

SCHEME

The tetrahedral adducts (2) derived from reaction of thioesters with alkyl-lithiums also serve as convenient sources of thioenolates. Thus when solutions of the adducts were warmed to room temperature in the presence of LDA, alkylation afforded the vinyl sulphides (6) in good yields

[†] All the thioesters reported in this communication are *O*-bonded, *i.e.* of the type C(:S)O.

(Table 2). This process may involve enolization of an *in situ*-generated thioetone or direct elimination from the tetrahedral adduct (2). Table 2 shows that the vinyl sulphides are often produced with high regioselectivity. When there is a choice in the positions adjacent to the thio-

TABLE 2. Conversion of thioesters into vinyl sulphides^a

Entry	(1)		R ³ CH ₂ Li	% Yield of (6)
	R ¹	R ²		
1	-[CH ₂] ₃ -		Pr ^a	73 ^b
2	-[CH ₂] ₅ -		H	82
3	-[CH ₂] ₅ -		Pr ^a	87 ^c
4	C ₆ H ₁₁ ^d	H	H	64 ^e
5	C ₆ H ₁₁	H	Pr ^a	60 ^{e,f}
6	Me[CH ₂] ₅	H	H	65 ^e

^a In a typical procedure *O*-ethyl cyclohexanethioate (7 mmol) was added to butyl-lithium (8.7 mmol) in tetrahydrofuran (100 ml) and tetramethylethylenediamine (5 ml) at -65 °C. After stirring for 1 h lithium di-isopropylamide (8.7 mmol) was added and the mixture was stirred at room temperature for (1 h). Methyl iodide (10.4 mmol) was then added and the solution was stirred at room temperature for 30 min. Work-up and short path distillation afforded 1.2 g (87%) of the pure vinyl sulphide. All new compounds gave correct combustion analyses and exact mass measurements. Regio- and stereo-chemical purity was established by ¹³C n.m.r. spectroscopy. ^b Ratio of *Z*- to *E*-isomers *ca.* 6:4:1. ^c No *E*-isomer was detected. ^d C₆H₁₁ = cyclohexyl. ^e Some enolization (5–10%) was noted in this reaction. ^f A mixture of two major products and two minor products was observed *via* ¹³C n.m.r. spectroscopy.

carbonyl group between primary, secondary, or tertiary (entries 4 and 6, 2, 1 and 3), the vinyl sulphide derived from the less substituted thioenolate is highly preferred. As expected where the positions have similar substitution (entry 5) a mixture of regioisomers is formed. The preference for formation of one stereoisomer is also quite striking. Using shielding values for the thiomethyl group,⁷ the observed chemical shifts for the vinyl protons are consistent with formation of predominantly the *Z*-isomer of the vinyl sulphides.

These results provide a convenient, high-yield preparation of monothioacetals⁸ (ketones *via* hydrolysis) and vinyl sulphides from readily available thioesters.⁹ The latter conversion is especially useful since it comprises a direct, one-pot, regioselective sequence from an acid derivative to vinyl sulphides¹⁰ which can be subsequently transformed to vinyl sulfoxides and sulphones. Furthermore, the tetrahedral intermediate (2) are candidates for trapping with other electrophiles.

We thank the National Science Foundation and the National Institutes of Health for partial support. L.N. is an American Oil Fellow (1977–1978) and J.S.S. a Camille and Henry Dreyfus Teacher-Scholar (1972–1977).

(Received, 17th April 1978; Com. 398.)

¹ A preliminary report was presented at the 172nd meeting of the American Chemical Society, San Francisco, 1976.

² For leading references see P. Beak, J. Yamamoto, and C. J. Upton, *J. Org. Chem.*, 1975, **40**, 3052.

³ E. Schaumann and W. Walter, *Chem. Ber.*, 1974, **107**, 3562.

⁴ E. Schaumann and W. Klein, *Tetrahedron Letters*, 1977, 3457.

⁵ Conventional procedures to acyclic monothioacetals often afford poor yields and mixtures of products: F. Kipnis, H. Soloway, and J. Ornfelt, *J. Amer. Chem. Soc.*, 1951, **73**, 1783; H. Bohme and H. Bentler, *Chem. Ber.*, 1956, **89**, 1470; see also E. P. Painter, *Tetrahedron*, 1965, **21**, 1337.

⁶ D. W. Emerson and H. Wynberg, *Tetrahedron Letters*, 1971, 3445.

⁷ L. M. Jackman, 'Applications of NMR Spectroscopy in Organic Chemistry,' Pergamon Press, New York, 1969, p. 185.

⁸ The utility of cyclic monothioacetals as a ketone protecting group has been noted: E. J. Corey and T. Hase, *Tetrahedron Letters*, 1975, 3267.

⁹ M. Mori, Y. Ban, and T. Oishi, *International J. Sulfur Chem., Part A*, 1972, **2**, 79; D. H. R. Barton, C. Chavis, M. K. Kaloustian, P. D. Magnus, G. A. Poulton, and P. J. West, *J.C.S. Perkin I*, 1973, 1571.

¹⁰ For specific related transformations, see: T. Kumamoto, K. Hasoi, and T. Mukayama, *Bull. Chem. Soc. Japan*, 1968, **41**, 2742; J. M. Beiner, D. Lacadet, D. Paquer, A. Thuiller, and J. Vialle, *Bull. Soc. chim. France*, 1973, 1979; K. Hartke and L. Peshkar, *Angew. Chem.*, 1967, **79**, 56.