

Fluoride Activation of Nucleophilic Displacement at Tetrahedral Phosphorus

By ROBERT J. P. CORRIU,* JEAN-PIERRE DUTHEIL, and GERARD F. LANNEAU

(Laboratoire des Organometalliques, Equipe de recherche associée au CNRS No. 554, Université des Sciences et Techniques du Languedoc, Place Eugène Bataillon, 34060 Montpellier-Cédex, France)

Summary Participation of fluoride anion in nucleophilic substitution at tetrahedral phosphorus implies the transient formation of *trans*-difluorophosphorane oxide.

FLUORIDES exert a reactivating action on phosphorylated cholinesterases.¹ They have been extensively studied also as catalysts in the preparation of biologically active models.² In 1977, Ogilvie reported a simple method for transesterification with CsF, *via* the intermediate fluorophosphates.³ More recently, the use of CsF allowed the isolation of stable hexaco-ordinated phosphorus species.⁴ Thus, the growing interest in the possibility of nucleophilic assistance at phosphorus⁵ or silicon^{6,7} justified a study of the solvolysis of six-membered-ring halogenophosphates, catalysed by added CsF. The stereochemical data obtained in this study are rationalized on the basis of an unexpected F⁻-activated process.

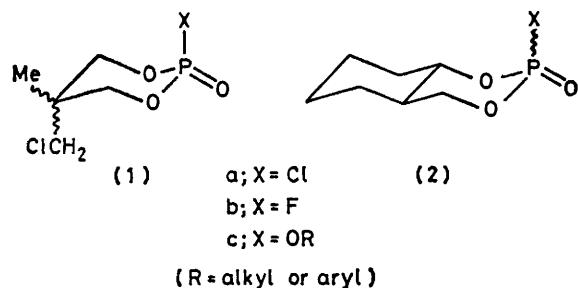

In the absence of fluoride, reaction of 2-chloro-2-oxo-1,3,2-dioxaphosphorinan, (**1a**), with alcohols or phenols is very slow (*e.g.* two weeks for Pr¹OH).⁸ The corresponding fluoride, (**1b**), is inactive. When CsF is added, however, the reaction is complete in several hours.

Cyclic halogenophosphates (**1**) and (**2**) were mixed with stoichiometric amounts of alcohols or phenols in the presence of 3 equiv. of CsF. Product ratios were determined *in situ* by ¹H and/or ³¹P n.m.r. spectroscopy, as previously described.⁹

The results are presented in the Table. In the case of (**1b**), isomerization is extremely fast relative to solvolysis and we could only characterize the thermodynamic mixture, *cis:trans* 73:27. On the other hand, the *trans*-fused system, (eq)-(**2b**), exchanges to the thermodynamically more stable (ax)-(**2b**) only slowly. The phosphate was always formed in the same ratio whatever the nature (chloride or fluoride) or isomeric composition of the reactant. This ratio was almost the same for all the phenols or alcohols investigated, *ca.* 50:50 for the monocyclic system (**1**) and *ca.* 85:15 (eq:ax) for the fused model, (**2**). Moreover, we noted that product ratios were (i) constant during the reaction, (ii) different from the thermodynamic ratio of the starting fluoro-derivative, and (iii) different from the thermodynamic ratio of the reaction product (Table). This was particularly noticeable for the bicyclic system, for which the predominantly formed isomer

TABLE

Reactant	Isomeric ratio <i>cis:trans</i>	Nucleophile	Product	
			Kinetic ratio <i>cis:trans</i>	Thermodynamic ratio <i>cis:trans</i>
(1a)	100:0	MeOH	54:55	71:29
"	"	EtOH	55:45	—
"	"	CCl ₃ CH ₂ OH	55:45	63:37
"	"	Pr ¹ OH	45:55	—
"	"	CH ₂ =CHCH ₂ OH	55:45	—
"	"	<i>p</i> -MeOC ₆ H ₄ OH	53:47	67:33
"	"	<i>p</i> -MeC ₆ H ₄ OH	54:46	67:33
"	"	PhOH	53:47	68:32
"	"	3,5-(OMe) ₂ -C ₆ H ₃ OH	53:47	—
"	"	2-Pr ¹ -5-Me-C ₆ H ₃ OH	53:47	—
"	67:33 ^a	<i>p</i> -MeC ₆ H ₄ OH	53:47	67:33
(1b)	73:27 ^a	MeOH	55:45	71:29
"	"	CCl ₃ CH ₂ OH	55:45	63:37
"	"	<i>p</i> -MeC ₆ H ₄ OH	55:45	67:33
"	0:100	Pr ¹ OH	45:55	—
"	"	<i>p</i> -MeC ₆ H ₄ OH	55:45	—
(1c ; R = CH ₂ CCl ₃)	20:80 ^b	CCl ₃ CH ₂ OH	55:45	63:37
"	"	Pr ¹ OH	45:55	—
(1c ; R = Pr ¹)	0:100 ^b	Pr ¹ OH	0:100	—
(2a)	0:100 ^c	<i>p</i> -MeC ₆ H ₄ OH	85:15 ^c	0:100 ^e
"	"	PhOH	85:15 ^c	0:100
"	"	CCl ₃ CH ₂ OH	76:24 ^{c,d}	"
(2b)	0:100 ^c	<i>p</i> -MeC ₆ H ₄ OH	85:15 ^c	"
"	20:80 ^c	"	80:20 ^c	"
"	35:65 ^c	"	83:17 ^c	"
"	0:100 ^c	PhOH	87:13 ^c	"

^a Thermodynamic ratio. ^b Reactions carried out at 80 °C for 60 h (ref. 3). ^c eq:ax. ^d The product is slowly isomerized under the reaction conditions.

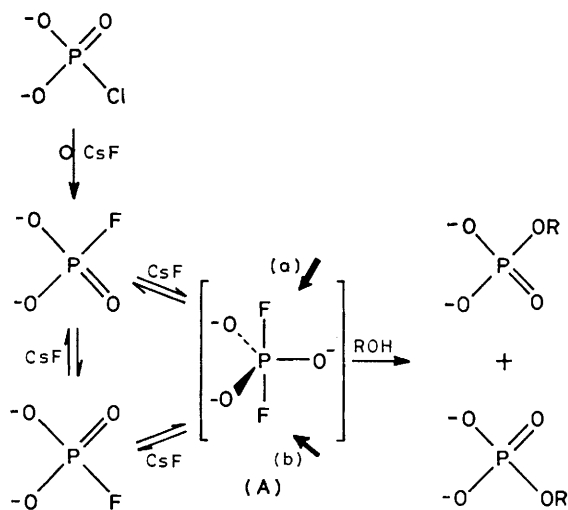

SCHEME

(Received, 4th November 1980; Com. 1191.)

† The more stable *trans*-fused compounds, (ax)-(2), are those with the electronegative substituent in the apical position (D. Bouchu and J. Dreux, *Tetrahedron Lett.*, 1979, 3151; M. Haemers, R. Ottenger, J. Reisse, and D. Zimmermann, *ibid.*, 1971, 461; D. G. Gorenstein and R. Rowell, *J. Am. Chem. Soc.*, 1979, **101**, 4925, and references therein). The equatorial isomer, (eq)-(2c) ($\text{X} = -\text{OC}_6\text{H}_4\text{Me}$), gives the axial isomer after 3 days in a large excess of *p*-cresol, in the presence of CsF . In contrast, substitutions of halogenophosphates take place in a matter of hours.

¹ E. Heilbronn, *Acta Chem. Scand.*, 1964, **18**, 2410; *Biochem. Pharmacol.*, 1965, **14**, 1363; C. Fest and K. J. Schmidt, 'The Chemistry of Organophosphorus Pesticides,' Springer Verlag, Berlin, 1973, p. 266.

² C. W. Tullock and D. D. Coffman, 1960, **25**, 2016; K. K. Ogilvie and S. L. Beaucage, *J. Chem. Soc., Chem. Commun.*, 1976, 443.

³ K. K. Ogilvie, S. L. Beaucage, N. Thérault, and D. W. Entwistle, *J. Am. Chem. Soc.*, 1977, **99**, 1277.

⁴ J. J. H. M. Font Freide and S. Trippett, *J. Chem. Soc., Chem. Commun.*, 1980, 157.

⁵ See e.g., S. Trippett, 'Organophosphorus Chemistry,' Specialist Periodical Report, The Chemical Society, London, 1979, Vol. 10; R. J. P. Corriu, G. F. Lanneau, and D. Leclercq, *Tetrahedron*, 1980, **36**, 1617; F. Ramirez, V. A. V. Prasad, and J. F. Marecek, *J. Am. Chem. Soc.*, 1974, **96**, 7269; F. Ramirez, J. F. Marecek, and H. Okazaki, *ibid.*, 1976, **98**, 5310; M. Koenig, A. Kläbe, A. Munoz, and R. Wolf, *J. Chem. Soc., Perkin Trans. 2*, 1976, 955; G. Aksnes, *Phosphorus Sulfur*, 1977, **3**, 227.

⁶ R. J. P. Corriu and M. Henner, *J. Organomet. Chem.*, 1974, **74**, 1; R. J. P. Corriu, G. Dabosi, and M. Martineau, *ibid.*, 1978, **154**, 33.

⁷ For the use of CsF as catalyst, see J. Boyer, R. J. P. Corriu, R. Perz, and C. Reyé, *J. Organomet. Chem.*, 1978, **157**, 153; 1980, **184**, 157.

⁸ W. S. Wadsworth, Jr., S. Larsen, and H. L. Horten, *J. Org. Chem.*, 1973, **38**, 156.

⁹ R. J. P. Corriu, J. P. Dutheil, G. F. Lanneau, and S. Ould-Kada, *Tetrahedron*, 1979, **35**, 2889.

¹⁰ I. Granth, Y. Segall, D. Wayshort, E. Shirin, and H. Leader, *J. Am. Chem. Soc.*, 1980, **102**, 4523.