

Novel catalysis of dendrimer-bound Pd(0) complexes: sterically steered allylic amination and the first application for a thermomorphic system

Tomoo Mizugaki, Makoto Murata, Masahiko Ooe, Kohki Ebitani and Kiyotomi Kaneda*

Department of Chemical Science and Engineering, Graduate School of Engineering Science, Osaka University, 1-3 Machikaneyama, Toyonaka, Osaka 560-8531, Japan.

E-mail: kaneda@cheng.es.osaka-u.ac.jp

Received (in Cambridge, UK) 16th August 2001, Accepted 22nd November 2001

First published as an Advance Article on the web 13th December 2001

Phosphinated dendrimer-bound Pd(0) complex catalysts show high stereoselectivity for allylic amination due to the surface congestion of dendrimers and can be easily recycled without loss of activity under thermomorphic conditions.

Dendrimers are novel macromolecules with monodispersed molecular weights, precisely determined cascade structures, and a specific number of the end groups.¹ One of the promising applications of metallo-dendrimers is in catalysis.² Organometallic dendrimers offer potential in building the gap between homogeneous and heterogeneous catalysis because of their structurally well-defined and specific number of active sites as well as their advantage of facile recovery by nano-filtration or solvent precipitation.³ The characteristic structures of dendrimers have been expected to enhance selectivities, but, there are few reports on positive catalytic effects due to the dendritic structures.⁴ Here, we report the synthesis of dendrimer-bound Pd(0) complexes and their unique catalysis for allylic substitution reactions.⁵ Furthermore, facile recovery of the dendritic Pd complexes can be achieved by the use of a thermomorphic system,⁶ which enables the temperature-induced phase separation of the homogeneous catalyst solution from a product phase. Thermomorphic behavior has also been reported in some catalytic systems, *e.g.* in a fluoruous biphasic by Horvath and Rabai⁷ and for soluble PNIPAM-supported metal complexes by Bergbreiter *et al.*⁶ To our knowledge, thermomorphic catalyst systems including dendrimer-bound metal complexes have not, as yet, been reported.

Double phosphinomethylation of primary amino groups on the 1st, 3rd, 4th and 5th generation of poly(propylene imine) dendrimers were carried out giving 4, 16, 32 and 64 chelate phosphines on the periphery (**1a–d**), respectively, as shown in Scheme 1.^{3b} Treatment of the dendrimers **1a–d** with PdCl₂(PhCN)₂ afforded dendrimer-bound PdCl₂ complexes **2a–d**. Subsequently, reduction of the Pd(II) dendrimers **2** with hydrazine monohydrate in the presence of two equivalents of PPh₃⁸ led to the formation of dendritic Pd(0) complexes **3a–d**, respectively, with retention of the parent dendritic structures. These Pd complexes were characterized by ¹H,

¹³C{¹H}, ³¹P{¹H} NMR, IR and XPS.[†] The ³¹P{¹H} NMR spectrum of **2** did not show any signal for the residual free phosphine at δ –27 but only one singlet at δ 8, and elemental analysis of **2** gave a Pd:P:Cl ratio of 1:2:2, which strongly supports the complete complexation of the chelate phosphine to Pd in a *cis* form.^{4b} After the reduction of **2**, the above resonance at δ 8 was fully replaced by a new one around δ 27. From XPS analysis of **2**, the band observed at 338 eV assignable to Pd 3d_{5/2} is comparable with that of a typical Pd(II) complex such as PdCl₂(PPh₃)₂, and the band at 336 eV for dendritic Pd complex **3** is due to a Pd(0) species.⁸

Catalytic performances of Pd(0) dendrimers **3** was examined in allylic substitution reactions of allylic acetates with amines

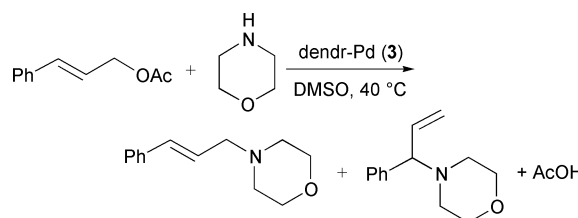

[*eqn. (1)*].^{5‡} For example, the substitution of *trans*-cinnamyl acetate with morpholine catalysed by **3b** smoothly proceeded to give the corresponding allylic amines in >99% yield (1:b = 90:10) within 30 min. The dendritic catalysts **3** were soluble in DMSO and it turned out to be the best solvent to study the catalytic reactions while CH₂Cl₂ and THF were not effective due to the low solubilities of the dendritic catalysts in these solvents. In the case of Pd(PPh₃)₄, DMSO, CH₂Cl₂ and THF were all good solvents. This substitution reaction using the dendritic catalysts could be also extended to include soft carbon nucleophiles and other allylic derivatives such as carbonates. van Leeuwen and coworkers reported that increased regioselectivity for the branched product was observed on going to the higher generation of a core functionalised dendritic Pd catalyst.⁹ In contrast, changing the generation of our surface functionalised dendritic catalysts did not affect the regioselectivity among linear and branched products.

The prominent catalysis of dendritic Pd complexes **3** was further investigated in the amination of *cis*-3-acetoxy-5-carbomethoxycyclohex-1-ene with morpholine. Notably, the stereoselectivity for a *cis* product increased with increasing the 3rd to the 5th generation of dendrimers as shown in Fig. 1: a high *cis* selectivity of 94% was obtained with **3d**, while Pd(PPh₃)₄ as a typical monomeric Pd(0) catalyst led to a slight excess of *cis* product. The 1st and the 3rd generations of the dendritic catalysts **3a** and **3b** showed moderate *cis* selectivity, respectively. In order to clarify the origin of the stereoselectivity, ¹³C spin–lattice relaxation times (*T*₁) of the dendritic ligands **1a–d** were measured (Fig. 1).[§] *T*₁ of peripheral phenyl groups on **1a–d** decreased with increasing the generation of the dendrimers, and this phenomenon shows that the dendrimer surface becomes more congested for higher generations.¹⁰ In the case of **3d**, attaining high stereoselectivity of the substitution reaction can be explained by steric steering of the nucleophilic

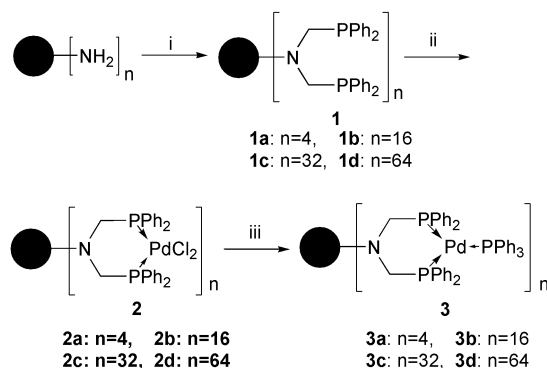

Scheme 1 Preparation of dendritic Pd(II) complexes **2** and Pd(0) complexes **3**. Reagents and conditions: i, HCHO, HPPH₂, toluene, 60 °C; ii, PdCl₂(PhCN)₂, toluene, room temp.; iii, H₂NNH₂·H₂O, PPh₃, EtOH, room temp.

attack to a surface (π -allyl)Pd intermediate, *i.e.* the active sites would be strongly shielded from the *endo* attack of the nucleophile. The moderate selectivity with **3a** and **3b** might be due to the loosely packed dendrimer surfaces, which would allow the partial dissociation of chelate phosphine ligands.¹¹ Similar stereoselective performances in allylic aminations due to steric hindrance of solid supports have also been observed by Trost and others using polystyrene- and silica-bound Pd(0) complex catalysts.¹²

Recycling of dendritic metal complex catalysts was attempted by solvent precipitation^{3b} or membrane filtration,^{3d} which often results in some losses of the catalytic activities during the recovery and reuse processes. Fortunately, our dendritic Pd(0) catalysts **3** could be easily recycled by using a biphasic system of DMF and heptane and the system does not need any special procedures such as membrane filtration.¶ The two phases consisting of DMF and heptane became homogeneous when heated up to 75 °C, and then could be readily separated by cooling the reaction mixtures to room temperature. Extremely low solubility of the dendrimers **3** in the apolar heptane solvent meant the catalysts were completely transferred to DMF and the catalyst solution could be recycled after decantation of the heptane phase containing products. For example, in the allylic substitution of *trans*-cinnamyl acetate with dibutylamine, the high catalytic activity was retained during three reuse experiments: yields of the allylic amine in heptane phase were 66% (1st), 99% (2nd), 99% (3rd) and 99% (4th run), respectively.¶ This is the first application of dendritic catalysts in a thermomorphic system.

In conclusion dendrimer-bound Pd(0) complexes have been synthesised by reduction of dendritic Pd(II) complexes with hydrazine. They show high stereoselectivity for allylic amination ascribed to the surface congestion of the dendrimers. Employing a thermomorphic system makes it possible to efficiently recycle the dendritic catalysts. We expect that the above results could give a clue to more sophisticated catalyst designs of dendrimers for highly selective organic syntheses.

This work is supported by the Grant-in-Aid for Scientific Research from the Ministry of Education, Science, Sports and Culture of Japan (12750691 and 11450307). We are grateful to the Department of Chemical Science and Engineering, Graduate School of Engineering Science, Osaka University for scientific

support via the 'Gas-Hydrate Analyzing System (GHAS)' and the Lend-Lease Laboratory System.

Notes and references

† Selected data: for **1b**: ¹H NMR (CDCl₃): δ 7.16–7.33 (m, 320H, Ph), 3.50 (br, 54H, NCH₂P), 2.76 (br, 32H, CH₂NCH₂P), 2.17–2.34 (br, 92H, CH₂NCH₂CH₂, NCH₂CH₂CH₂NCH₂P), 1.42 (br, 60H, NCH₂CH₂CH₂N, NCH₂CH₂CH₂CH₂N). ³¹P{¹H} NMR (CDCl₃): δ -27. For **2b**: ³¹P{¹H} NMR (DMSO-*d*₆): δ 8. XPS: 343.4 eV (Pd 3d_{3/2}), 338.3 eV (Pd 3d_{5/2}). IR (CsI) 294 cm⁻¹ (*cis* Pd–Cl). For **3b**: ³¹P{¹H} NMR (DMSO-*d*₆): δ 27. XPS: 342.0 eV (Pd 3d_{3/2}), 336.8 eV (Pd 3d_{5/2}).

‡ Typical reaction conditions: *trans*-cinnamyl acetate (1.5 mmol), morpholine (1.8 mmol), catalyst (5 μ mol of Pd atoms), DMSO (5 mL), 40 °C, Ar atmosphere.

§ Because of the low solubility of the dendrimers **3**, *T*₁ for the dendrimers **1** in place of **3** was measured by the inversion–recovery method.

¶ Reaction conditions for the thermomorphic catalysis are as follows: dendritic catalyst (10 μ mol of Pd atoms), DMF (1.5 mL), dibutylamine (1.8 mmol), triethylamine (1.5 mmol), heptane (3 mL), and *trans*-cinnamyl acetate (1.5 mmol) were added in a Schlenk type flask under Ar and stirred at 75 °C for 1 h. For reuse experiments, heptane, allylic acetate, a nucleophile and triethylamine were added subsequently after decantation of the heptane phase. These procedures were repeated three times.

|| The relatively low yield for the fresh run was due to the distribution of allylic amine product in the DMF phase. No Pd leaching in the heptane phase was observed during recycle experiments according to ICP (detection limit is 0.1 ppm).

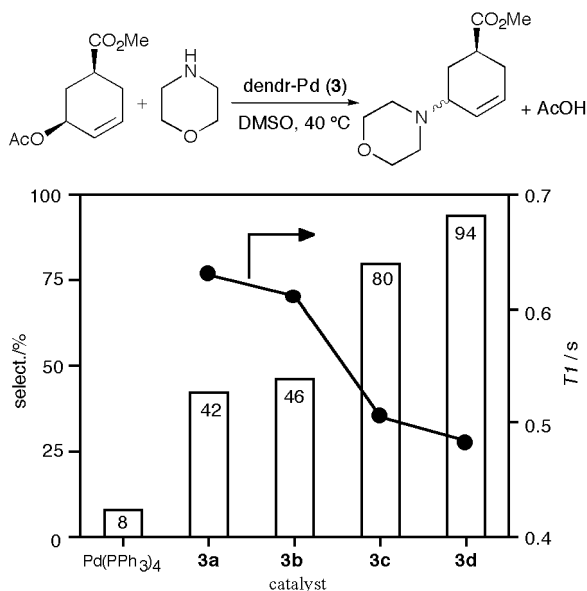

Fig. 1 Generation dependence on selectivity in the allylic amination of *cis*-3-acetoxy-5-carbomethoxycyclohex-1-ene with morpholine. Stereoselectivity for *cis* isomer was compared at 30% conversion of the substrate. Selectivity (%) = [(*cis* - *trans*)/(*cis* + *trans*)] × 100. *T*₁ values were calculated for the C4 carbon (128 ppm) in the phenyl groups of the corresponding dendrimers **1**, respectively.

- Reviews and a book on dendrimers: (a) D. A. Tomalia, H. Baker, J. R. Dewald, M. Hall, G. Kallos, S. Martin, J. Roeck, J. Ryder and P. Smith, *Polym. J.*, 1985, **17**, 117; (b) F. Zeng and S. C. Zimmerman, *Chem. Rev.*, 1997, **97**, 1681; (c) A. W. Bosman, H. M. Janssen and E. W. Meijer, *Chem. Rev.*, 1999, **99**, 1665; (d) G. R. Newkome, C. N. Moorefield and F. Vögtle, *Dendritic Molecules: Concepts, Synthesis, Perspectives*, VCH, Weinheim, 1996.
- (a) G. R. Newkome, E. He and C. N. Moorefield, *Chem. Rev.*, 1999, **99**, 1689; (b) G. E. Oosterom, J. N. H. Reek, P. C. J. Kamer and P. W. N. M. van Leeuwen, *Angew. Chem., Int. Ed.*, 2001, **40**, 1828; (c) D. Astruc and F. Chardac, *Chem. Rev.*, 2001, **101**, 2991.
- (a) J. W. J. Knapen, A. W. van der Made, J. C. de Wilde, P. W. M. N. van Leeuwen, P. Wijkens, D. M. Grove and G. van Koten, *Nature*, 1994, **372**, 659; (b) M. T. Reetz, G. Lohmer and R. Schwickardi, *Angew. Chem., Int. Ed. Engl.*, 1997, **36**, 1526; dendritic catalysts for continuous flow membrane reactors, see: (c) N. J. Hovestad, E. B. Eggeling, H. J. Heidbuchel, J. T. B. H. Jastrzebski, U. Kragl, W. Keim, D. Vogt and G. van Koten, *Angew. Chem., Int. Ed.*, 1999, **38**, 1655; (d) D. de Groot, E. B. Eggeling, J. C. de Wilde, H. Kooijman, R. J. van Haaren, A. W. van der Made, A. L. Spek, D. Vogt, J. N. H. Reek, P. C. J. Kamer and P. W. N. M. van Leeuwen, *Chem. Commun.*, 1999, 1623; (e) N. Brinkmann, D. Giebel, G. Lohmer, M. T. Reetz and U. Kragl, *J. Catal.*, 1999, **183**, 163; (f) E. B. Eggeling, N. J. Hovestad, J. T. B. H. Jastrzebski, D. Vogt and G. van Koten, *J. Org. Chem.*, 2000, **65**, 8857.
- (a) C. Koellner, B. Pugin and A. Togni, *J. Am. Chem. Soc.*, 1998, **120**, 10274; (b) T. Mizugaki, M. Ooe, K. Ebitani and K. Kaneda, *J. Mol. Catal. A: Chem.*, 1999, **145**, 329; (c) R. Breinbauer and E. N. Jacobsen, *Angew. Chem., Int. Ed.*, 2000, **39**, 3604; (d) L. Ropartz, R. E. Morris, D. F. Foster and D. J. Cole-Hamilton, *Chem. Commun.*, 2001, 361.
- Reviews on allylic amination: (a) M. Johannsen and K. A. Jørgensen, *Chem. Rev.*, 1998, **98**, 1689; (b) A. Heumann, in *Transition Metals for Organic Synthesis*, ed. M. Beller and C. Bolm, Wiley-VCH, Weinheim, 1998, p. 251.
- (a) D. E. Bergbreiter, Y-S. Liu and P. L. Osburn, *J. Am. Chem. Soc.*, 1998, **120**, 4250; (b) D. E. Bergbreiter, P. L. Osburn, A. Wilson and E. M. Sink, *J. Am. Chem. Soc.*, 2000, **122**, 9058.
- I. Horvath and J. Rabai, *Science*, 1994, **266**, 72.
- M. Terasawa, K. Kaneda, T. Imanaka and S. Teranishi, *J. Organomet. Chem.*, 1978, **162**, 403.
- G. E. Oosterom, R. J. van Haaren, J. N. H. Reek, P. C. J. Kamer and P. W. N. M. van Leeuwen, *Chem. Commun.*, 1999, 1119.
- (a) A. M. Nayler, W. A. Goddard III, G. E. Kiefer and D. A. Tomalia, *J. Am. Chem. Soc.*, 1989, **111**, 2339; (b) J. F. G. A. Jansen, E. M. M. de Brabander-van den Berg and E. W. Meijer, *Science*, 1994, **266**, 1226.
- Z. Csakai, R. Skoda-Fördes and L. Kollár, *Inorg. Chim. Acta*, 1999, **286**, 93.
- (a) B. M. Trost and E. Keinan, *J. Am. Chem. Soc.*, 1978, **100**, 7779; (b) B. M. Trost and T. R. Verhoeven, *J. Am. Chem. Soc.*, 1980, **102**, 4730; (c) J. E. Bäckvall, K. L. Granberg and A. Heumann, *Isr. J. Chem.*, 1991, **31**, 17.