

NUCLEATION OF SUPERCOOLED WATER CLOUDS BY SILVER IODIDE SMOKES¹

BERNARD VONNEGUT

General Electric Research Laboratory, Schenectady, New York

Received October 18, 1948

ABSTRACT

Measurements have been carried out in a cold box on the nucleation of ice formation in supercooled clouds by silver iodide smoke particles. The smokes were produced by atomizing an acetone solution of silver and ammonium iodides into a hydrogen flame.

The measurements show that ice crystals do not form immediately on the silver iodide particles. The silver iodide can be regarded as greatly increasing the probability of ice crystal formation. The number of effective nuclei which can be produced per gram of silver iodide varies from about 10^{13} at -10°C. to 10^{16} at -20°C.

INTRODUCTION

About a year and a half ago, it was found that silver iodide smokes had the property of causing snowflakes to form in a supercooled cloud (5). It is believed that silver iodide particles are good nuclei for ice formation because of the close resemblance of their crystal structure to that of ice. Experimentation has been under way to learn more about the production and behavior of these smokes. The work to be described in this account should be regarded as preliminary. The techniques and apparatus used in the work frequently leave much to be desired in the way of precision. The results are tentative and await confirmation by better experiments. This work, despite the uncertainties in it, nevertheless sheds light on the mechanism of nucleation and suggests new experiments and improved techniques for giving a more complete picture of the phenomena associated with nucleation by silver iodide.

APPARATUS AND TECHNIQUES FOR MEASUREMENTS ON SMOKES

Wind tunnel

In order to determine the output of a source of silver iodide smoke, it is necessary to secure a sample of smoke for testing that is a known fraction of the total output. This was accomplished by diluting the output of the smoke generator with a large known flow of air, and taking a known volume of this dilute smoke for testing. The smoke generator was placed in front of a $\frac{1}{4}$ -horsepower electric fan, 3 ft. in diameter, which sucked the smoke along with a large volume of air into a crude wind tunnel 4 ft. square in cross-section and 24 ft. long. The stirring action of the fan and the turbulence in the tunnel mixed the smoke with

¹ Presented at the Symposium on Aerosols which was held under the joint auspices of the Division of Physical and Inorganic Chemistry and the Division of Colloid Chemistry at the 113th National Meeting of the American Chemical Society, Chicago, Illinois, April 22, 1948.

the air to produce a more dilute smoke, which was discharged at the other end of the tunnel where samples were taken. When a heavy white oil smoke was introduced into the tunnel, it appeared to be quite uniformly mixed and diluted as it left the tunnel. The rate of flow in the tunnel, as determined by measuring the velocity with a vane-type anemometer, was 4×10^6 cm.³ per second.

Of the silver iodide smokes used, all except the ones having the largest particle size were completely invisible under the conditions of the experiment. The smokes having the largest particles were quite transparent and of a pale blue or purple appearance in the sunlight.

Smoke sampling and diluting syringe

In many of the cases, only a fraction of 1 cc. of the smoke from the tunnel is needed for a test. Precipitation on the walls of a container of this size would be very rapid. Therefore, a syringe was constructed for taking a sample of the smoke and diluting it quantitatively to any desired amount. The syringe

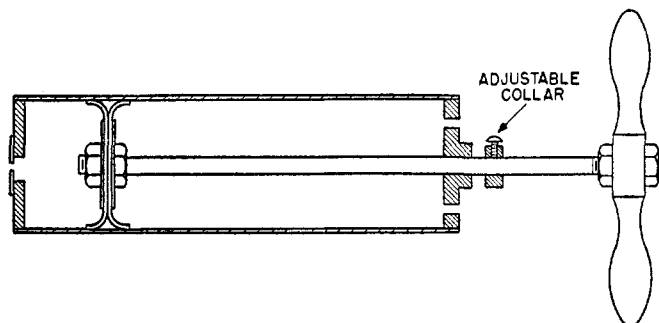

FIG. 1. Smoke sampling and diluting syringe

(figure 1) consists of a metal tube 3 in. in diameter with a piston and leather washers which can be moved back and forth a fixed distance. A sample of smoke was taken with the syringe and then diluted to the desired concentration by moving the piston in and out the requisite number of times in smoke-free air, upwind from the tunnel.

Cold chamber

The early measurements on the number of nuclei contained in silver iodide smokes were made using Schaefer's technique (3). A measured volume of smoke was introduced into a supercooled cloud in a home freezer and the number of snow crystals produced per cubic centimeter was visually estimated.

This technique has been slightly modified in the more recent work and the apparatus used is shown in figure 2. The tests were carried out in a brass cylinder 15 in. high and 12 in. in diameter having walls $\frac{1}{2}$ in. thick to provide good thermal conductivity.

This chamber, which was closed at the bottom, was maintained at a low temperature by placing it in a 4 cu. ft. home freezer. The freezer thermostat

was used to regulate the temperatures. A supercooled cloud was maintained in the refrigerated cylinder by evaporating water from wet paper toweling wound around a 15-watt electric heater placed in the lower part of the cylinder. A hinged masonite lid was used to close the top of the cylinder during tests. The temperature at the top of the cylinder was found to be about 2°C . warmer than at the bottom. The minimum temperature obtainable in the chamber was -20°C . In future experiments, it is highly desirable that lower temperatures be obtainable and that provisions be made for better temperature regulation.

Smokes were tested by introducing them from the sampling syringe into the supercooled cloud in the cylinder. A stack of cold microscope slides was placed in the bottom of the cylinder. The snowflakes produced by the action of the smoke settled on the bottom of the cylinder and on the topmost microscope

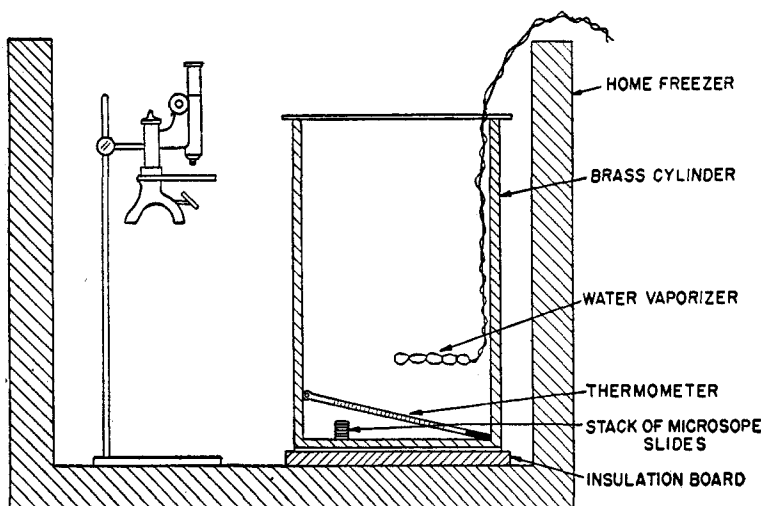

FIG. 2. Apparatus for counting nuclei in smoke

slide. At intervals 2 min. apart the slide on which the snow had fallen was removed, thus exposing the slide beneath. The slide which was removed was then examined under a microscope kept in the freezer. By means of a Whipple eyepiece, the number of flakes collected per square millimeter in a 2-min. period was counted. When the rate of snowfall had dropped to a low value, the total number of flakes which had fallen per square millimeter was determined by adding the numbers which had fallen in each 2-min. sample. The total number of snow crystals which would have been produced by the entire output of the generator could then be calculated from the area of the bottom of the cylinder, the volume and dilution of the smoke introduced, and the volume rate of production of the smoke.

Electron microscope examination of smoke

Smokes being tested were examined with the electron microscope to determine their appearance and particle size. Samples of smoke were precipitated

on a Formvar film supported on a fine wire screen, by moving it for about a minute in and out of the smoke stream about 3 ft. from the generator. The smoke stream at this point is still quite warm. The sample screen, because it is in the smoke only a moment at a time, remains cool so that thermal precipitation may play a part in the collection of the smoke.

Under these conditions of precipitation, it is quite likely that particles of a certain size may be selectively precipitated, so that the sample obtained is not entirely representative of the smoke. A more reliable method would be desirable so that more trustworthy data could be obtained.

The smoke samples were photographed using the electron microscope. Determinations of the particle size and the number of particles per cubic centimeter of material were made from these photographs.

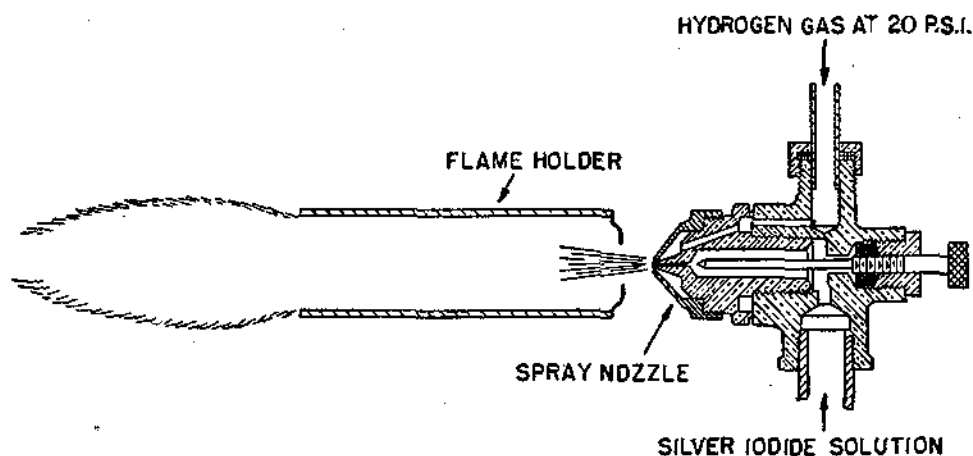

FIG. 3. Silver iodide smoke generator

Smoke generator

The smokes used in these tests were produced by a smoke generator constructed from a commercial compressed-air atomizing nozzle of the sort used for paint spraying and humidifying (Binks No. 174). The generator is shown in figure 3. Compressed hydrogen gas at 20 lb. per square inch was applied instead of air to the air inlet of the nozzle and a solution of silver iodide was used as the liquid to be sprayed. The hydrogen stream as it left the nozzle was ignited. The heat of the flame vaporized the silver iodide in the spray into a gas which, upon mixing with the atmosphere, condensed into a smoke of small silver iodide particles. In order to prevent the hydrogen flame from being blown out by the wind, a flame holder consisting of a piece of $\frac{3}{4}$ -in. pipe $2\frac{1}{2}$ in. long was placed $\frac{1}{2}$ in. from the spray nozzle. At a pressure of 20 lb. per square inch, the spray nozzle used about 3 cu. ft. of hydrogen per minute (measured at atmospheric pressure).

Silver iodide solutions

Although silver iodide is very insoluble in water and organic liquids, it is quite soluble in acetone or water solutions containing a soluble iodide such as sodium or ammonium iodide. The solutions used in this work were made by dissolving 200 g. of silver iodide and 100 g. of ammonium iodide in a mixture of

750 cc. of acetone and 250 cc. of water. A dilute solution was also used which was made by diluting the above solution to ten times its volume with acetone. Solutions can be diluted any desired amount with acetone; however, dilution with water causes precipitation of the silver iodide. Ammonium iodide was used in the solutions for these experiments because it probably is completely decomposed in the hydrogen flame, thus leaving a smoke of uncontaminated silver iodide.

The rate at which silver iodide was fed into the smoke generator was varied by controlling the rate of flow of solution by adjusting the valve on the nozzle and by using solutions of different concentrations.

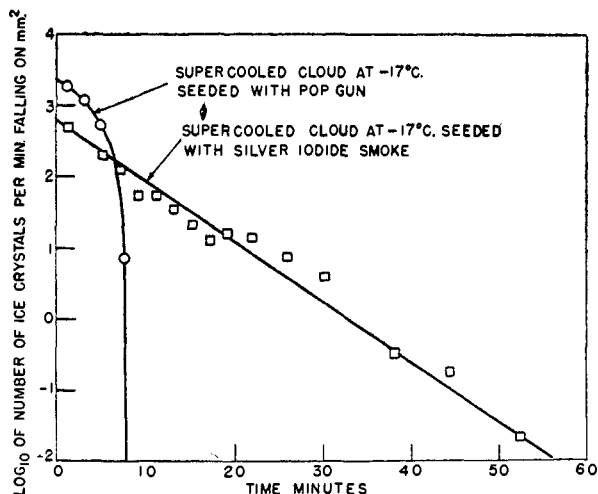

FIG. 4. Comparison of seeding with silver iodide smoke and seeding with popgun

EXPERIMENTAL RESULTS

Decrease in rate of snow formation after seeding

There was found to be a large difference in the behavior of the supercooled cloud when it was seeded with the low-temperature air produced by a popgun and when it was seeded with silver iodide smoke. From figure 4 it can be seen that although many snow crystals were produced by the low temperature from the popgun, all of these crystals had precipitated to the bottom of the container at the end of 10 min. When the cloud was seeded with silver iodide smoke, however, a measurable number of ice crystals were still precipitating at the end of almost an hour. The rate of snowfall decreases to one-half each 2 or 3 min. This rate of decrease was not found to vary significantly with temperature or with the particle size of the smoke although, as will be seen, the total number of snow crystals varied over several factors of ten, depending on the temperature of the supercooled cloud.

Precipitation of smoke in syringe

One possible source of error in these experiments is that which might be caused by coagulation and precipitation of the smoke in the sampling syringe. In

order to evaluate this rate of disappearance, tests were made in which small smoke samples were withdrawn from the syringe after it had been in the syringe for varying periods of time. The number of effective nuclei in a sample of smoke was found to decrease by one-half every 20 min. The time required to take, dilute, and discharge a sample into the cold chamber was never more than a minute or two, so that the changes in the smoke occurring during this time were not large.

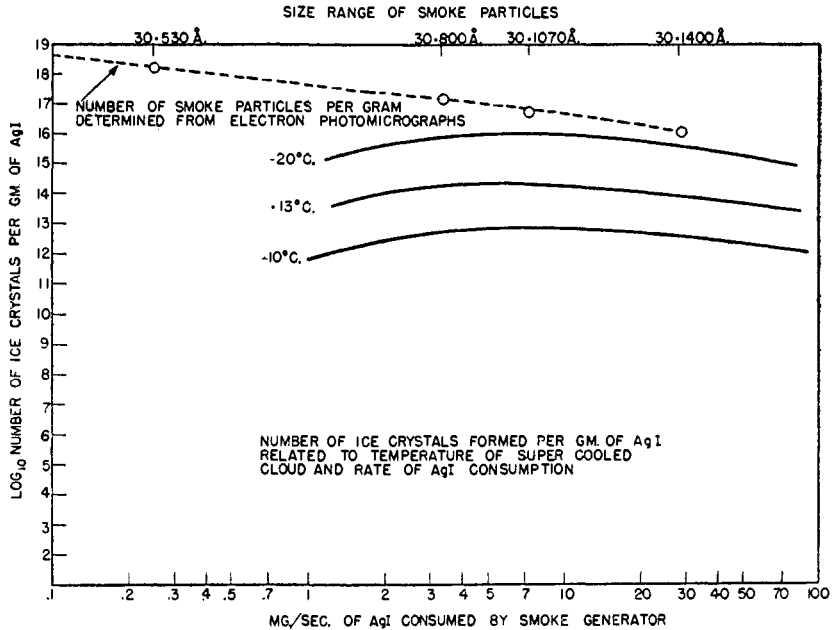

FIG. 5. Number of ice crystals formed per gram of silver iodide related to temperature of supercooled cloud and rate of silver iodide consumption.

Number of ice crystals per gram of silver iodide

The results of experiments carried out with different settings of the smoke generator and in supercooled clouds at different temperatures are shown in figure 5. In this graph, the results are also given for the electron microscope examination.

Electron photomicrographs were made of four different samples of smokes. A hundred or more particles in a representative section of each photograph were measured, and a graph was made of the number of particles as a function of their diameter. All of the smokes examined showed a large number of particles having a diameter of about 30 Å., which is the smallest particle observable with the microscope. It, therefore, seems probable that in these smokes there are many more particles which were too small to be resolved. By neglecting these invisible particles, it was possible to estimate the minimum number of

particles formed per gram of silver iodide by dividing the number of particles in a representative section of a photograph by the sum of their masses computed on the assumption that they were spheres having the same density as silver iodide crystals. Figure 6 shows electron photomicrographs of two typical smokes.

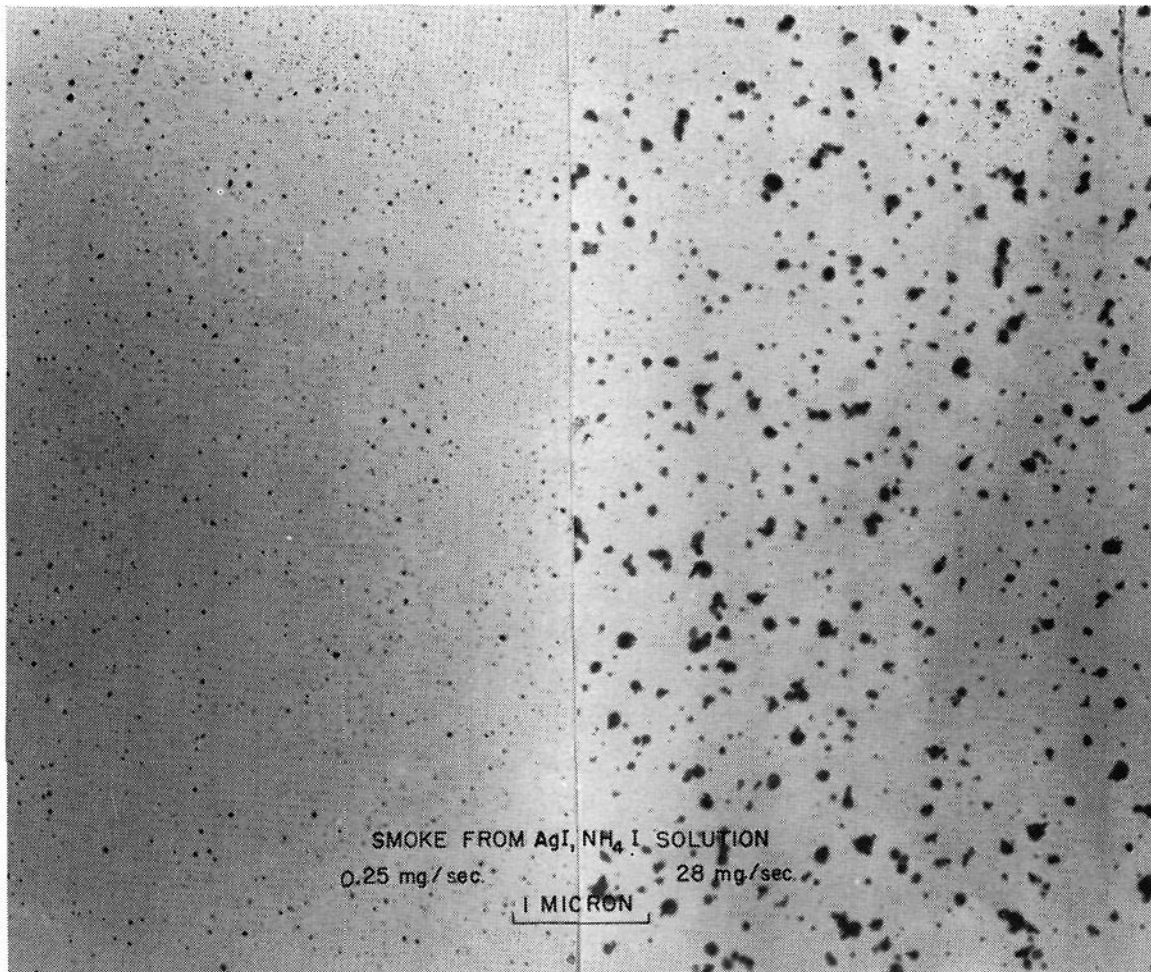

FIG. 6. Smoke from silver iodide-ammonium iodide solution. (a) 0.25 mg./sec.; (b) 28 mg./sec.

DISCUSSION OF RESULTS

The work thus far is not of sufficient scope to give straightforward answers to many questions which arise concerning the mechanism of silver iodide nucleation. It is the purpose of this discussion to venture some possible explanations for the experimental observations.

Formation of ice crystals

Figure 4, which shows the number of snow crystals precipitating per minute after seeding, illustrates a significant difference between the behavior of a cloud seeded with silver iodide and one seeded by a popgun. Seeding with a popgun or dry ice produces very large numbers of small ice crystals by cooling a small region of the cloud to a temperature at which spontaneous nucleation takes

place. These ice crystals then mix with the cloud and grow at the expense of the supercooled water drops. From figure 4 it can be seen that although a large number of ice crystals is produced by the popgun, all of these crystals have precipitated out at the end of 10 min. Now if all of the silver iodide particles put into the cloud formed ice crystals at the time they were introduced, they, too, should have precipitated out at the end of 10 min. However, at the end of almost an hour, ice crystals are still precipitating. This leads one to the conclusion that all of the silver iodide particles do not form ice crystals immediately and that even at the end of half an hour or more, appreciable numbers of silver iodide particles have not yet formed snow crystals and are still present in the cloud.

There are various possible explanations for the time required for silver iodide particles to initiate the formation of ice crystals in a supercooled cloud. One possibility is that in order for an ice crystal to form on a crystal of silver iodide, a certain critical number of water molecules must by chance arrange themselves on its surface in the structure of ice. According to this explanation, a silver iodide particle would not act as a nucleus until this event took place. The presence of a silver iodide surface might be regarded as merely greatly increasing the probability of the formation of ice.

If we take a simplified view of the theory of nucleation as advanced by Gibbs, in supercooled water or in a region supersaturated with respect to ice, the water molecules by chance, from time to time, arrange themselves in the lattice of crystalline ice. If these minute aggregations are smaller than a certain size, their vapor pressure is greater than that of the supersaturated region and they are unstable and break up. If, on the other hand, they are larger than a certain size, their vapor pressure is such that they are stable and continue to grow. The lower the temperature, the smaller will be the critical size necessary for stability. Schaefer (4) found, using clean air free of dust, that the rate at which nuclei form is very low at temperatures above -38.9°C . However, in the presence of a silver iodide surface, it is possible, because of the close similarity between ice and silver iodide, that the probability of the chance formation of a nucleus is greatly increased and is large even at temperatures as high as -10°C .

Another way of looking at the phenomenon is to consider the growth of an ice crystal as the formation of a crystal of ice on ice. We know that this takes place with the greatest ease. The formation of ice on a large surface of ice requires the formation of very little new ice surface; hence there is little change in surface energy. For every new ice surface formed, an almost equal ice surface is covered up. However, when a new ice surface is formed in the absence of any other surface, large amounts of surface energy are required relative to the free energy decrease in the formation of the interior of the new phase. Because of the close similarity of ice and silver iodide, the formation of ice on a silver iodide surface probably involves only a small amount of surface energy, and therefore the chances of this taking place are good.

The lower the temperature, the smaller will be the critical size of a stable nucleus. Because the critical size is small at low temperatures, the chances of

a nucleus forming are, in general, better. Hence, the rate of nucleus formation is generally greater at low temperatures.

Another possible explanation for the time required for silver iodide particles to form ice crystals can be based on the assumption that the silver iodide particles produced by the generator are not all in the hexagonal form which is similar to ice. Possibly they might exist in a metastable condition as a supercooled liquid or as some other modification. In this case, the rate at which they react to form ice crystals would be determined by the rate at which they transform into the stable hexagonal form. However, it appears for several reasons that this factor is probably not large in these experiments. It has been found that the silver iodide smokes used in these tests will nucleate silver iodide solutions supersaturated with respect to the hexagonal form and that the crystals which result are of the hexagonal variety. The number of such nuclei in a given volume of smoke is of the same order of magnitude as the number of particles determined by the electron microscope. It, therefore, seems probable that at room temperature most of the smoke particles are of the hexagonal structure. In addition one would expect, if the rate-determining factor involved the transformation of the silver iodide particles themselves, that smokes aged for a period of time at low temperature would show a different rate of falling off of ice crystal formation when they are put in a supercooled cloud. This has not been observed.

Another possibility is that the formation of an ice crystal under the influence of a silver iodide particle can take place only in the liquid phase. In this case, the rate of ice crystal formation might be limited by the rate at which silver iodide particles entered into supercooled water drops. This could occur either by diffusion of the particle to the drop or by condensation of a drop on a particle. It has been found that when a suspension of silver iodide particles in water is sprayed into a supercooled cloud, ice crystals are formed. It is therefore probable that silver iodide particles can act as nucleating agents in a drop of liquid water. However, it has not been definitely established that this is a necessary condition for silver iodide to act. If we assume this to be the rate-governing factor in these experiments, we are faced with the problem of explaining the large effect of temperature on the total number of ice crystals produced. As will be discussed later, the variation of the number of ice crystals produced with temperature can be explained on the basis that the rate of nucleation increases greatly with decreasing temperatures. There is no reason to expect that the rate at which particles enter water drops is particularly temperature-sensitive. It is quite possible that the time required for a particle to enter a water drop is of considerable importance in these experiments, but it is probably not the most important rate-governing factor.

The interpretation of results is further complicated by the possibility that small particles of silver iodide smoke may dissolve in water drops before they have a chance to start the formation of an ice crystal. At 25°C. the solubility of silver iodide in water is about 1×10^{-8} moles per liter (1). A water drop 10 microns in diameter on this basis should be capable of dissolving a silver iodide particle about 100 Å. in diameter. The solubility should be somewhat greater

for particles of this small size. However, the effect of particle size should be counteracted to some extent by a decreased solubility at the lower temperatures. If these factors are of importance, the kinetics of the nucleation may be dependent to a large extent on the rate of solution of the silver iodide particles in the water drops.

The author is inclined to favor the explanation that the rate of ice crystal formation is governed primarily by the rate of spontaneous ice nucleus formation on the silver iodide particles. In some as yet unreported experiments on the nucleation of supercooled water and supercooled tin, the author measured at constant temperature the rate of solidification of systems composed of a number of independent supercooled drops. It was observed that the drops did not all freeze at once but froze at a rate which steadily decreased with time. This rate of freezing increased greatly as the temperature was lowered. In these experiments, foreign particles and surfaces were present which undoubtedly served as foreign nuclei. The time required for these drops to freeze could be best explained on the basis of the chance formation of stable nuclei on the foreign surfaces. It seems reasonable to believe that in the case of nucleation by silver iodide similar phenomena play a dominant rôle.

If we proceed on the assumption that silver iodide merely increases the rate of the chance formation of spontaneous ice crystals, it is possible to come to some conclusions as to the magnitude of the rate and its dependence on temperature. Some of the particles of silver iodide introduced into the cold chamber undoubtedly become lost as potential nuclei by precipitation on the walls of the chamber. The rate of precipitation on the walls is probably large because of thermal diffusion resulting from the 15-watt heater in the vaporizer. One would expect the rate at which particles disappear by precipitation on the walls to be proportional to the concentration of the particles. On the basis of this assumption, the concentration of particles would decrease exponentially with time. If the rate of snow formation is proportional to the concentration, this too should decrease exponentially with time. This is experimentally observed to be the case.

On the basis of the foregoing assumptions, one can analyze the situation mathematically.

If c is the number of silver iodide particles per unit volume at a time t then:

$$\frac{dc}{dt} = -(K_1 + K_2)c \quad (1)$$

where K_1 is the rate at which the silver iodide particles form ice crystals and K_2 is the rate at which they are being removed from the cloud by precipitation or other causes. By integrating equation 1 we obtain an expression for the concentration c at any time:

$$c = c_0 E^{-(K_1+K_2)t} \quad (2)$$

where c_0 is the concentration at time $t = 0$. If N is the number of ice crystals

formed per unit volume, then

$$\frac{dN}{dt} = K_1 \cdot c = K_1 c_0 E^{-(K_1+K_2)t} \tag{3}$$

which when integrated gives for the number of crystals formed at time t :

$$N = \frac{K_1 c_0}{K_1 + K_2} \cdot 1 - E^{-(K_1+K_2)t} \tag{4}$$

Or when precipitation is complete

$$N = \frac{K_1}{K_1 + K_2} \cdot c_0 \tag{5}$$

or

$$\frac{N}{c_0} = \frac{K_1}{K_1 + K_2} \tag{6}$$

The fact that the rate at which the rate of snowfall decreases with time is not greatly influenced by temperature, while the total number of crystals produced increases by a large factor with a small temperature decrease, indicates that at higher temperatures K_2 is far greater than K_1 . This is another way of saying that at higher temperatures the rate at which the silver iodide particles form snowflakes is so small that a large majority of them precipitate on the container walls before they have a chance to form snow crystals. At -20°C . the number of snow crystals obtained approaches the number of particles determined from the electron microscope, so that it is reasonable to assume that at this temperature most of the smoke particles form snowflakes.

If we assume that the rate at which precipitation decreases with time at the higher temperature is determined solely by K_2 , then K_2 computed from the curve in figure 4 is approximately 6×10^{-3} per second. From the data in figure 5, N_1 and c_0 can be estimated and from them and the above value for K_2 , values for K_1 for different smokes at different temperatures can be computed.

These values expressed as half-life in hours are as follows:

SILVER IODIDE	RANGE OF PARTICLE DIAMETER	HALF-LIFE	
		-13°C .	-10°C .
<i>mg./second</i>	<i>Å.</i>	<i>hours</i>	<i>hours</i>
1.5	30-700	5.5	173
7.5	50-1070	1.9	75
37.5	130-1400	1.4	67

If these data are extrapolated on the assumption that the log of the nucleation changes linearly with the reciprocal of the absolute temperature, we find that at -5°C . the half-life is several years, while at -20°C . it is a few seconds, and at -25°C . a few milliseconds.

This large effect of temperature on the nucleation rate is of the same order of magnitude as that observed in the measurements on supercooled water drops and on supercooled tin drops.

The curves in figure 5 show a maximum for the number of nuclei produced per gram of silver iodide at a certain rate of silver iodide consumption. This is probably because at a low rate of consumption, the particles produced are so small that their reaction rate is small and many of them precipitate out before they have a chance to serve as nuclei. At high rates of consumption, the particles formed are larger and react more rapidly, but because they are larger, fewer are formed per gram of silver iodide.

Diffusion coefficients of smoke

An average diffusion coefficient for the silver iodide smoke can be calculated from measurements made on the rate at which the smoke precipitates on the walls of a container. In the experiments which were made to find the rate at which the number of nuclei falls off as a function of the time the smoke is held in the sampling syringe, it was found that the half-life of the smoke was about 20 min. This was for a smoke produced when the generator was consuming 20 mg. of silver iodide per second.

Langmuir (2) has derived the following expression for the rate of precipitation of a smoke of diffusion coefficient D on the walls of a container having a volume V and an internal area A with slight convection caused by a slightly higher temperature at the bottom than the top:

$$\frac{d \ln c}{dt} = \frac{0.64AD^{2/3}}{V} \quad (7)$$

where c is the concentration of the smoke at any time t .

Using this equation the diffusion coefficient is calculated to be approximately 6×10^{-5} .

Langmuir (2) has also given the following expression for the diffusion coefficient as a function of particle radius:

$$D = \frac{2.04 \times 10^{-16}}{a^2} + \frac{1.18 \times 10^{-11}}{a} \quad (8)$$

where a is the particle radius.

According to this expression, the diffusion coefficient 6×10^{-5} corresponds to a particle diameter of 400 Å. This is in reasonable agreement with the measurements from the electron microscope, which show this smoke to have a particle diameter ranging from 30 Å. to 1400 Å. with a median diameter of about 300 Å.

As has been shown, K_2 , or the rate of disappearance in the cold chamber of silver iodide particles from causes other than nucleation, is about 5.7×10^{-3} per second.

Using the diffusion coefficient of 6×10^{-5} and equation 7, it can be calculated that the smoke concentration should fall at a rate of 1.3×10^{-4} per second. This is far less than the observed rate of decrease, K_2 , which was found to be 5.7×10^{-3} . This calculation, of course, does not take into account the thermal diffusion caused by the vaporizer heater in the cold chamber, which would be expected to increase greatly the rate of precipitation on the walls.

Using the diffusion coefficient it is possible to estimate the rate at which the

concentration of the smoke decreases because of precipitation on the water drops of the supercooled cloud. It can be shown that the rate of change of concentration due to this cause is given by the relation

$$\frac{d \ln c}{dt} = -4\pi D r_0 Q \quad (9)$$

where r_0 is the radius of the water drops and Q is the number of drops per cubic centimeter.

If we assume the liquid water contents to be 1 g. per cubic meter and the drop radius to be 5 microns, the rate of change of concentration from this cause is 3.6×10^{-4} .

SUMMARY

Measurements have been carried out on the nucleation of supercooled water clouds by silver iodide smokes. The smokes were produced by spraying a solution of silver iodide into a hydrogen flame. The particles of the smokes were found by electron microscope examination to range in diameter from 30 Å. to 1400 Å. The number of ice crystals produced per gram of silver iodide was determined as a function of the temperature of the supercooled cloud and the rate of introduction of silver iodide into the flame. Yields of ice nuclei of as high as 10^{16} per gram of silver iodide were obtained when the supercooled cloud was at -20°C . At -10°C . the same smoke produced only $10^{12.7}$ ice crystals per gram.

It has been found that silver iodide particles do not react immediately to form ice crystals when they are put into a supercooled cloud. Ice crystals were found to be still forming at a measurable rate 50 min. after a silver iodide smoke was introduced into a supercooled cloud. It is believed that fewer ice crystals are produced at higher temperatures than at lower temperatures, because the silver iodide particles react more slowly to form ice crystals and most of them precipitate on the walls of the cold chamber before they have time to react.

According to this interpretation of the results, the rate of reaction at -13°C . is thirty or forty times that at -10°C .

The author wishes to thank Dr. Irving Langmuir and Dr. Vincent J. Schaefer for their very helpful counsel and suggestions in this work. He is grateful to Mr. E. Fullam for making the electron microscope examinations and photographs and to Mr. Kiah Maynard and Mr. Duncan Blanchard for invaluable help in testing the smokes.

The research reported in this paper was made possible through support extended the Research Laboratory of the General Electric Company jointly by the Signal Corps and the Navy Department (Office of Naval Research) under Signal Corps Contract No. W-36-039-SC-32427.

REFERENCES

- (1) HILL, A. E.: *J. Am. Chem. Soc.* **30**, 68 (1908).
- (2) LANGMUIR, I.: Unpublished work.
- (3) SCHAEFER, V. J.: *Science* **104**, 457-9 (1946).
- (4) SCHAEFER, V. J.: *Bull. Am. Meteorol. Soc.* **29**, 175-82 (1948).
- (5) VONNEGUT, B.: *J. Applied Phys.* **18**, 593-5 (1947).