

THE PREPARATION AND MEASUREMENT OF THE CONCENTRATION OF DILUTE BACTERIAL AEROSOLS^{1, 2}

RONALD M. FERRY, LEO E. FARR, JR., AND MARY G. HARTMAN

Department of Bacteriology and Immunology, Harvard Medical School, Boston, Massachusetts

Received October 18, 1948

Since the suspicion that disease may be airborne is centuries old, it is not surprising that medical scientists have long been concerned with the properties of airborne particulate suspensions. Following the rise of modern bacteriology, the medical significance of dilute aerosols has become clear. And, since many bacteria may be cultured to form particles with nearly uniform size and shape, characteristic of a given species, aerosols derived from bacterial suspensions may be profitably studied. Knowledge so gained should extend the understanding of colloidal phenomena and also clarify the mechanism of airborne disease.

Quantitative studies surely depend on, first, methods for generating uniform dilute aerosols, second, accurate measurement of their concentration and, third, with living organisms, on their collection and enumeration by biological methods, and further understanding of the physical properties of particulates. Although methods of generation are not completely satisfactory, concentration has been determined by the method of impingement and direct photoelectronic count. The latter method is convenient, rapid, and accurate provided particle size somewhat exceeds 0.7μ . Although impingement yields results consistent with the dimensionless group,

$$\frac{\rho V D^2}{\eta l}$$

derived by May and Sell, a comprehensive theory must include such factors as particulate asymmetry, the physical characteristics of the particulate and collecting surfaces, and the microaerodynamics of the impinger used. Biological enumeration is not only slow, but apparently limited by the efficiency of impingement methods. Simultaneous application of photoelectronic and biological methods should help increase understanding of aerosols composed of solid particles.

INTRODUCTORY REVIEW

Since disease has long been associated with airborne agents, it is not surprising that medical scientists have long concerned themselves, implicitly or explicitly, with the study of aerosols. Indeed, the suspicion that infection may be airborne is probably as old as medicine itself. In *The Evolution of Modern Medicine*, Osler (66) cites Maspero (59) as his authority for stating that "the Egyptians believed that disease and death were not natural and inevitable, but were caused by some malign influence which could use any agency, natural or invisible, and

¹ Presented at the Symposium on Aerosols which was held under the joint auspices of the Division of Physical and Inorganic Chemistry and the Division of Colloid Chemistry at the 113th National Meeting of the American Chemical Society, Chicago, Illinois, April 22, 1948.

² This paper is based upon work sponsored in part by the Biological Department, Chemical Corps, Camp Detrick, Frederick, Maryland, under Contract No. W18-064-CWS-151 with Harvard University.

very often belonged to the invisible world." Fifty or sixty centuries were to pass before the nature of some of the invisible agencies began to be apprehended. Our understanding is, of course, to be attributed to the rise of bacteriology and the concomitant development of appropriate investigative tools late in the nineteenth and early in the twentieth century. More recently virology has further clarified our understanding of many other diseases. And it is now proven that the air we breathe is a disease vector.

None the less, the importance of airborne factors has been obscured until recently by at least two factors. In the first place, Manson (58) in 1879 demonstrated that mosquitoes were responsible for the spread of filariasis. Subsequently, insect vectors have been associated with such diseases as malaria, plague, and typhus. Second, it has been technically more difficult to obtain evidence directly connecting airborne particles with disease. For although airborne dust particles are ubiquitous and generally numerous, their sizes range from a small fraction of a micron upwards and completely efficient collection is difficult. Moreover, only a small proportion of those particles may be expected to contain an infectious agent.

None the less, epidemiological investigations of the more common respiratory diseases such as pulmonary tuberculosis (1), influenza, and the common cold demonstrate the importance of airborne agents (16). On this basis, air sterilization by ultraviolet light (27, 57) or by chemical agents (4, 5, 15, 26, 28, 29, 31, 42, 54, 60, 70, 71, 72, 74, 75, 87, 88) has been applied to their control. These methods will not be reviewed here. Nor have laboratory studies of airborne infection been neglected (1, 3, 23, 24, 26, 32, 55, 68, 75, 77, 80, 86, 89, 93, 94). These studies have generally been based on exposure of animals to aerosols generated by the atomization of living suspensions of the infectious agent. The concentration of the bacterial aerosol was usually estimated from samples collected either in liquids or semisolids by means of a modified Greenburg-Smith (77) impinger, a cotton filter, or by means of the Wells air centrifuge (92). The estimate of the number of organisms contained in the sample rested primarily on counts of the number of bacterial colonies appearing in plate cultures of an aliquot.

Although the results obtained by these methods are extremely valuable, the methods are time consuming, often inconvenient, and affected by the many variables encountered in biological systems. Moreover, they provide no possibility for direct estimation of the ratio of living to dead organisms in the aerosols studied. And this information appears necessary for an understanding of the factors affecting viability and consequent infectivity. Despite the recent contributions of Rosebury (77) and Robertson (74) and his coworkers, further information seems desirable.

Injury to the respiratory tract and respiratory infection have been related to invasion of the respiratory tract (11, 12, 17, 18, 20, 30, 43, 50, 52, 85, 95). Rooks (76) has reported a study of bacterial penetration. Further studies relating penetration not only to the size and dispersion but to other physical

properties of the particles appear desirable. Recently Wilson and La Mer (97) have reported a study with radioactive tracers.

Moreover, information concerning the number of bacteria necessary to produce infection in man and animals would appear to depend on rapid and accurate methods of determining the particulate count in rather dilute aerosols.

Finally, certain bacterial species may be grown under conditions such that their size and shape are nearly uniform, although characteristic of each species. Since size varies about twentyfold from 0.4 to 8.0 μ , and the shape from the almost spherical cocci to the thin rodlike bacilli, it is possible to secure valuable physical information concerning aerosols containing particles differing not only in size but also shape, from a study of airborne bacteria. Unlike most solid particles, their density is low.

As a result of these considerations, it seemed to us that quantitative laboratory studies depended on: (1) a method for the preparation of pure bacterial aerosols at low concentrations, from one hundred to a few thousand per liter, and preferably containing only single cells of nearly uniform size; (2) a rapid and accurate method for determining the number of particles in such suspensions; and (3) a satisfactory method for collecting and enumerating the number of living bacteria in aerosols. We believed that the first requirement could readily be met by slight modification of existing methods for atomizing liquid suspensions of particles. We hoped that the photoelectronic counter, which utilizes a lens system developed by La Mer and Sinclair (47) and a photoelectronic, amplifying, and counting system developed by Gucker (38), would satisfy the second. And we expected that these methods combined with the use of one of the devices frequently used for collecting airborne organisms would satisfy the third requirement. This paper describes the first and appraises the second method, and in partly appraising the third, suggests that further scrutiny of the methods may be necessary. For convenience, the methods are treated in separate sections. In their present form, they are applicable only to laboratory studies and are not yet sufficiently refined to permit the study of individual particles much smaller than 1.0 μ .

Since Gucker's photoelectronic counter has been extensively used by us, and is often referred to, it is briefly described here. It is more fully described in a preceding paper (39). This instrument depends primarily on light scattering by small particles suspended in air (83, 90). The apparatus is schematically shown in figure 1, to parts of which reference is made by letter.

By means of appropriate lenses (A, B) and stop system (C), a hollow cone of light is brought to a rather deep focus, through which an air stream may be passed. This part of the apparatus we shall subsequently call the smoke cell. Unless the air contains particles, the rays pass outside a small collecting lens (E). If suspended particles are present, light is scattered with maximal intensity in the forward direction. Some of the scattered light enters lens D and is brought to a focus at diaphragm E. It then excites a photocell (F); the resulting impulses are amplified by an appropriate electronic system and

may be electronically or mechanically recorded. For further details, the reader is referred to Gucker's papers (38, 39).

I. GENERATION OF DILUTE BACTERIAL AEROSOLS

A. Introduction

Accurate studies of aerosols appear to depend on the production of homogeneous suspensions of uniformly sized single particles in air. Although the treatment of spherical particles is simpler, the theory of light scattering is sufficiently developed for the consideration of less symmetrical particles (7, 19, 45, 47, 62, 65, 69, 81, 98). Since the Gucker instrument with a Thalofide photocell responds accurately only if the counting rate is less than 1000 per minute (38), dilute aerosols are essential for study.

Bacterial aerosols can be readily generated (13, 74, 77, 88), and, provided the test organisms are suitably selected, reasonable uniformity of particle size is attainable. Perfect spherical symmetry is not readily realized, for although cocci are nearly spherical, they grow in clumps which are not readily broken. Consequently, the resistant spores of *B. globigii* and the sensitive vegetative form *S. marcescens* were chosen. These organisms have similar symmetry, and ap-

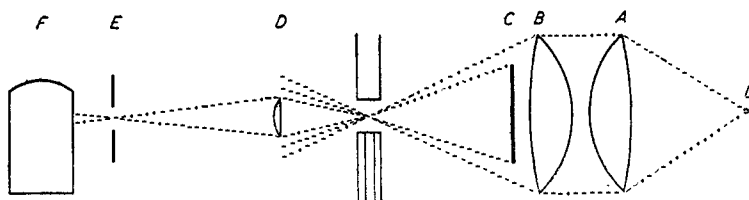

FIG. 1. Schematic representation of optical system for photoelectronic counter

pear as ellipsoids of revolution with axes in the former case about $0.8 \times 1.2 \mu$ (8), in the latter approximately $0.6 \times 0.8 \mu$ (8). Microscopic examination showed little variation in the individual cells of each species. The difference in size seemed suitable for fixing the limit below which the photoelectronic instrument fails accurately to estimate concentration. Moreover, penetration of the respiratory tract, which depends on particle size and dispersion (11, 12, 43, 50, 95), is near a maximum in this size range, and our studies have a biological as well as physical orientation. Finally, the difference in size appeared to permit theoretical analysis.

In generating bacterial aerosols, the following precautions should be observed: (1) Leakage inwards or outwards is not permissible; the former will contaminate the aerosols, the latter will pollute room air. (2) Humidity must be controlled and readily measurable, since the death rate of bacteria apparently has a critical maximum at about 50 per cent relative humidity (25). (3) Diluting air must be carefully filtered, not only to avoid bacterial contamination, but also to eliminate adventitious photoelectronic counts. Future quantitative studies, especially with live infectious agents, depend on observing all of these precautions. For many purposes, this has not been necessary.

Simple atomization of bacterial suspensions either in water, broth, or other media, followed by simple dilution in a chamber (74, 77, 87, 93, 94), has generally sufficed. The atomizers used may be classified as refluxing or direct. Both depend on the shearing effect of a high-velocity air stream which is directed across an orifice through which the liquid passes and is broken into droplets. In the former, only smaller droplets and particles escape (34, 77, 87), while larger droplets return to the reservoir. Consequently some of the fluid is repeatedly atomized so that partial evaporation of the larger droplets within the atomizer causes concentration of the suspension atomized and consequent concentration of the aerosol. In the direct type concentration is avoided, but droplets are larger (87). With either type the observed aerosol concentration is less than that calculated from air flow and the volume and concentration of the suspension atomized (77, 87). This effect is much greater with refluxing than with direct atomizers and may be attributed to impingement of incompletely dried droplets on nearby surfaces (13). Further attenuation is readily observed in regions of turbulence, as in mixing chambers.

The recovery of particles in an aerosol prepared with a given atomizing and diluting system is, under controlled conditions, almost constant. For example, in our experience with atomizer 8 and a *B. globigii* suspension, recovery was about 35 per cent of that expected. The liquid orifice may, however, unexpectedly become occluded so that constant control of particulate concentration at the point of use is essential.

After careful consideration, the refluxing type was deliberately chosen for use in our studies, since it had been reported to produce aerosols composed chiefly of single bacterial cells, presumably by breaking up bacterial clumps by repeated reatomization. For our purposes, uniform particulate size was more important than constant concentration. Further improvements in atomizer design should make it possible to maintain more nearly constant concentration of aerosols.

B. Methods

A general description of the apparatus used is followed by a brief description of certain important procedures.

Atomizer: Readily available Vaponefrin atomizers were modified by the introduction of an additional baffle, as shown in figure 2, and used for atomization of washed particulate suspensions in distilled water. Under these conditions, the particle size is uniform and is determined by that of the suspended particles. Satisfactory uniformity of the aerosol has been shown by study of impinged samples by light-field, dark-field, and phase-difference microscopy. Less than 5 per cent of the particles appeared as doublets; no clumps, and only traces of very minute foreign particles were observed. Breakage of dead bacteria used in impingement studies is probably insignificant at jet velocities less than 150 m. per second. These points deserve emphasis.

In constructing the atomizing and diluting system shown diagrammatically in figure 3, we were aided by suggestions from Gucker and his group. As in figure 3, filtered air at constant pressure maintained by two Mason-Neilan

regulating valves in series enters the system at the left, passing first through a copper coil, then through distilled water in a Pyrex gas-washing bottle, and subsequently through a coiled trap (not shown) to the atomizer. These parts were immersed in a water bath at 28°C. in order nearly to saturate the atomizing air. Other parts of the dilution system were placed in a bath at 25°C. The

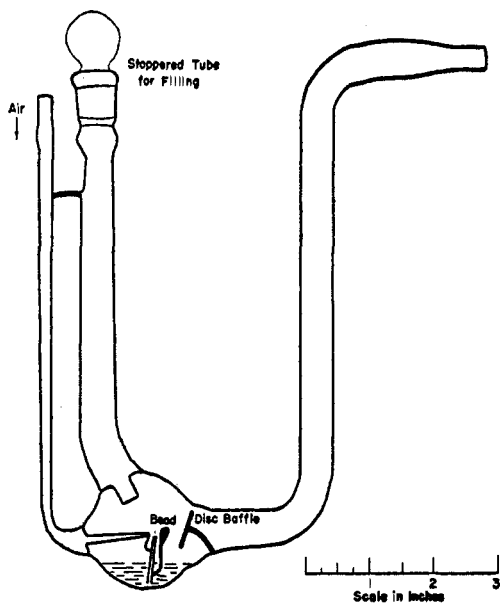

FIG. 2. Modified Vaponefrin nebulizer

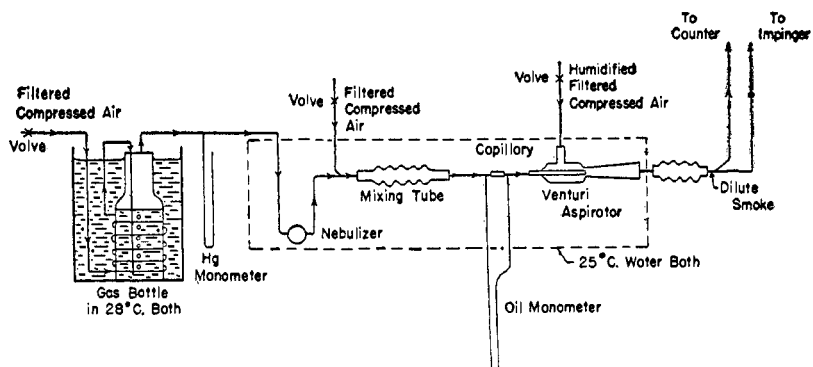

FIG. 3. System for aerosol generation and air dilution. Room temperature = 25°C.

atomizer mist was at once diluted with a measured volume of filtered air at known humidity, and passed through a mixing chamber consisting of a series of bulbs about 2 cm. in diameter. The mist evaporated almost immediately, and a small fraction of the aerosol passed through a capillary flowmeter into a venturi tube where it was again diluted with a known volume of air. At the end, simul-

taneous sampling with the photoelectronic instrument and impingers or other collecting devices was possible. Not shown on the diagram are outlets for the collection and disposal of excess aerosol. The excess eventually passed into a common duct in which it could be sterilized by ultraviolet radiation, or heat, or both.

The flow of diluting air was measured with calibrated capillary flowmeters. Dilution factors could thus be calculated from observed flow rates.

The humidity of the aerosol was manually controlled by mixing saturated and dry, or partly dried, air. It was measured with an Alnor Dewpointer. Since the dilution ratio in the final stage is 40:1, measurement of the humidity of the diluting air instead of the aerosol should be sufficiently accurate and safer when virulent organisms are used.

With this system we have prepared aerosols, composed predominantly (95 per cent upwards) of single bacterial particles at a concentration of 100–5000 particles or $5\text{--}250 \times 10^{-11}$ g. per liter. The relative humidity of the aerosols studied was generally about 62 per cent.

Counter operation: Since the photomultiplier tube had not been successfully applied in the Gucker instrument when these studies began, a Thalofide cell was used throughout. The procedure described by Gucker (38) was somewhat modified.

(1) Air flow through the smoke cell was half that given by Gucker. Smoke was sampled at 0.5 l. per minute; sheath air flowed at 1.5 l. per minute.

(2) The 6–8 v. tungsten filament bulb was supplied from four-cell storage batteries instead of three, producing a voltage drop up to 7.0 v. across the filament and markedly increasing light intensity. Although the lamps burned out after 4–8 hr., they could readily be replaced.

(3) A scale of sixty-four scaler was interposed between the phototube amplifier and the thyratron tube.

C. General

Those components of the apparatus in which the pressure was likely to exceed that of the atmosphere, including all of the atomizing and diluting system, were placed in a separate room which was maintained at slightly reduced pressure by ventilation with an exhaust fan. The effluent could be sterilized by heat or ultraviolet radiation. Leakage into the outer room was thereby avoided.

In the outer rooms were the electrical apparatus, vacuum pumps, smoke cell, and sampling outlet. Aerosols contained in parts of the smoke line passing into the outer room were generally at reduced pressure so that accidental leaks would be inward. Openings could be protected by efficient filters.

D. Preparation of bacterial suspensions

The preparation of bacterial suspensions is briefly described in appendix A.

E. Results

In figure 4 the photoelectronic count of *S. marcescens* aerosols appears as ordinate, and time as abscissa. The photoelectronic instrument rapidly follows

the concentration effect observed with reflux atomizers. The solid lines are calculated in terms of atomizer delivery at constant air pressure and volume, temperature, and water content of the expanded atomizing air, by means of a simple equation of the form

$$C_t = C_0 \frac{V_0 - at}{V_0 - bt}$$

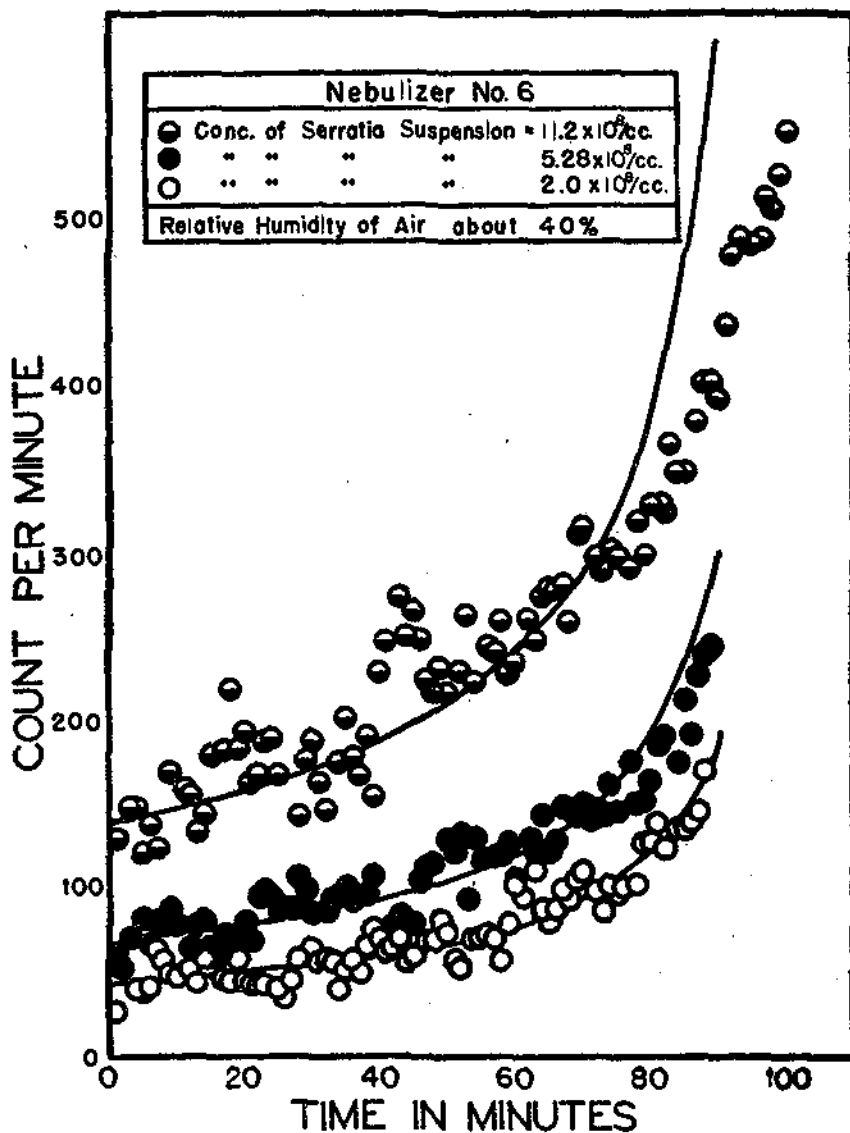

FIG. 4. Instantaneous direct photoelectronic measurement showing increasing aerosol concentration.

where C_t is the count at time t in minutes, C_0 is the initial count, b is the observed weight loss per minute at observed temperature, humidity, and air pressure, $a = (b$ minus the evaporative loss sufficient to saturate the initial mist).

The values a and b are characteristic for each atomizer, and their systematic variation with air pressure, temperature, and humidity could be computed. They may, however, be obtained by atomizer calibration. The computations suggest that constant aerosol concentration might be attained by adding water to the liquid suspension at a rate equal to that of evaporative loss.

The parallelism of the concentrations of the aerosol and of the bacterial suspension in the atomizer has been shown by comparing direct bacterial counts made at the beginning and end of an experiment³. These ratios, compared with those of the corresponding photoelectronic counts, are, within the experimental error, unity. They do not show how completely the photoelectronic instrument enumerates bacterial particles. Other methods are necessary for this determination.

With *B. globigii* suspensions, the course of events is similar, but sometimes obscured by spontaneous clumping in the suspension which partially blocks the atomizer. These concentration phenomena are surely significant when atomizers of this type are used to administer drugs as aerosols.

II. COMPARISON OF THE PHOTOELECTRONIC INSTRUMENT WITH AN INDEPENDENT PHYSICAL METHOD

A. Introduction

Comparison with an independent physical method was desirable in order to find out whether photoelectronic counts were complete, and to determine the smallest particle size at which satisfactory counts were possible. For this purpose, comparison with biological methods seemed inappropriate, since possible changes in the viability of suspended organisms would introduce uncertainty. In order to avoid errors due to changes in concentration, it was necessary to compare samples taken simultaneously.

Inasmuch as the Gucker instrument, at least in its original form, had a frequency response limited to 1000 counts a minute (38), particulate concentrations could not exceed 1000 per liter at a flow rate of 1 l. a minute, or 2000 per liter at half this rate. Consequently many existing methods, most of them reviewed by Drinker and Hatch (21) and by Heymann (44), were not suitable for making comparisons. The methods described by them utilize the following principles for collection of particles from the air: (1) thermal precipitation, (2) filtration, (3) electrical precipitation, and (4) impingement. (5) In addition, we seriously considered a direct count of particles containing radioactive materials by means of a Geiger counter. (6) Use of an electrostatic counter devised by Guyton (41) appeared unsuitable, since it is not sufficiently sensitive (39).

In the first four methods, estimation of concentration is derived either from microscopic observation, weighing, or analysis; in the last two, directly from air flow and count of electrical impulses.

(1) For our purposes *thermal precipitation* (2, 35, 91, 96) appeared unsuitable, since the sampling rate of about 6 cc. per minute would introduce large sampling errors at low concentrations unless the sampling period were prolonged. In that case, errors attributable to changing aerosol concentrations were certain unless control of concentration was precise. (See also Rosenblatt and La Mer (77a).)

(2) Filtration also appeared not to provide a satisfactory approach, since quantitative recovery of particles from either soluble or insoluble filters did not seem assured (77).

³ Ferry, Farr, and Hartman: Unpublished data.

(3) Electrical precipitation (6, 22, 73, 82), at least without considerable modification, appeared to spread a deposit over so wide an area that accurate direct counts were likely to be difficult at the low aerosol concentrations studied. Washing off the deposit, followed by concentration and subsequent enumeration, seemed a precarious approach.

(4) Impaction or impingement on a surface seemed promising. There are numerous variants such as:

(a) Simple settling: This is slow and ineffective with particles as small as 1μ or less (33).

(b) Centrifugation: Wells' centrifuge is intended primarily for cultural studies. With it, collection efficiency appears uncertain (14).

(c) Bubblers
(d) Washing } Neither of these methods is adapted for the study of dilute

aerosols, composed of dead bacteria, since particles cannot be readily counted without concentration and transfer (36, 37). It is difficult to be certain that this procedure is rigorously quantitative.

(e) Impingers: The studies of Owens (67) and, among others, the more recent studies of May (61) and Sonkin (79) suggested that at appropriate jet velocities particles somewhat smaller than 1μ in diameter, and with a density near unity, might be nearly quantitatively recovered and counted. This method was therefore used for appraising the photoelectronic counter.

(5) We seriously considered the use of a Geiger counter to count particles containing radioactive material. Specious counts due to the presence of minute radioactive particles outside the bacteria were possible, and proof of their absence seemed difficult. It was not attempted.

B. Methods

Impinger details: After preliminary experiments had shown that neither a cascade impactor (61, 79) nor a Bausch and Lomb dust counter (40) produced deposits sufficiently symmetrical or well defined to make accurate particulate count possible, the impinger shown in figure 5 was made. In its present form, it resembles Owens' jet impinger (67) and consists of a simple slit jet which impinges on a glass disc held at a fixed distance from the orifice.

It is composed of two main parts, one containing the jet and slide holder, the other a funnel-shaped piece through which the aerosol leaves the collector. The parts can be tightly closed by a large nut which fits over the outer threaded surface of the funnel-shaped piece. Consequently small metal particles, produced by tightening the threads, cannot be caught in the air stream and deposited in a second impinger. Sharp corners have been eliminated to minimize deposition except on the collecting slide. The design of the collecting chamber is such that air flow divides symmetrically on either side of the jet orifice. Stainless-steel construction permits frequent sterilization.

Two types of jet, both shown in figure 6, were tried. The tapered jet shows less apparent constriction and probably induces less turbulent flow. None the

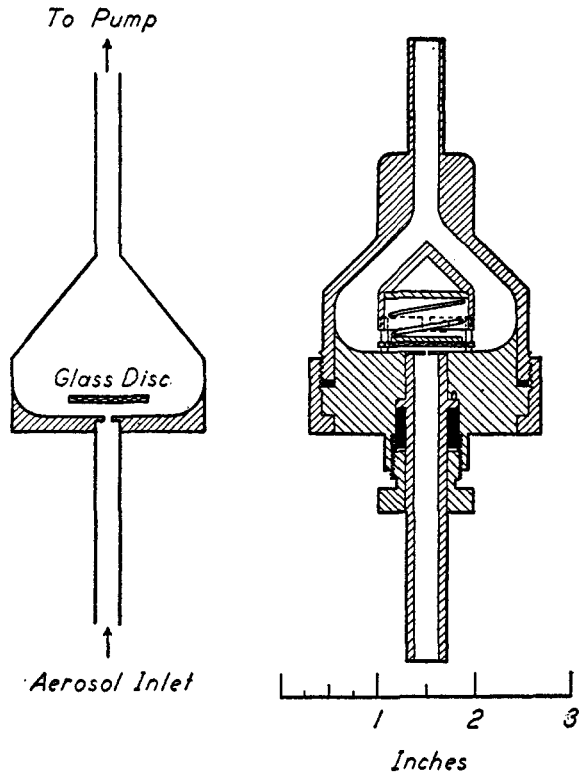

FIG. 5. Stainless-steel impinger: left, schematic drawing; right, scale drawing

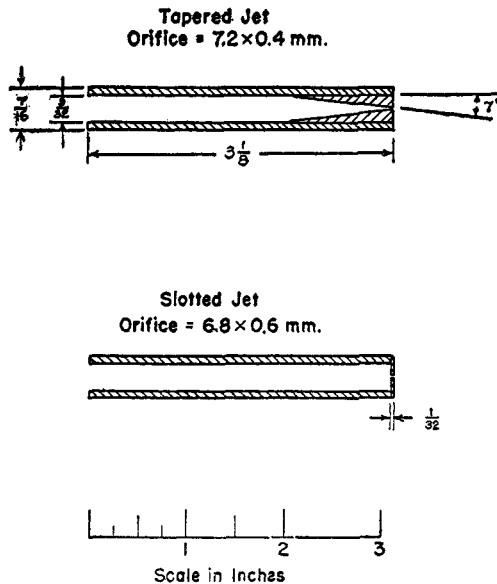

FIG. 6. Impinger jets

less, the simple rectangular slit 6.8 x 0.6 mm., with carefully polished edges, resulted in about 1.5 times better recovery.

Calibration was in terms of air flow, measured in liters per minute with a standard rotameter accurate to about 3 per cent, and pressure, in millimeters of mercury, at room temperature $25^{\circ}\text{C.} \pm 0.5^{\circ}$. The effective cross-section and the apparent constriction factor were calculated from the observed air flow at critical pressure drop. The latter turned out to be about 0.8, a reasonable value. Average linear jet velocities were, in turn, calculated from the effective cross-section, air flow, and pressure-volume relations.

Although the jets were intended to be alike, one was slightly larger than the other. The larger orifice was placed second when two impingers were used in series, with the result that calculated jet velocities differed by not more than 3 per cent at air flow up to 21 l. per minute. At 25 l. per minute the difference was about 12 per cent.

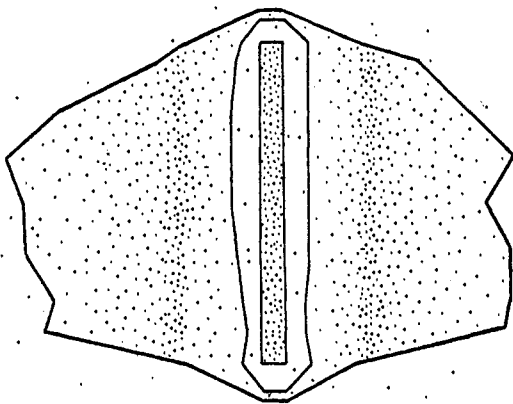

FIG. 7. Diagrammatic representation of a typical impinger deposit. Jet deposit and halo pattern for slotted jet.

Air flow through the impingers was actuated by a mechanical vacuum pump having a capacity of 12 cu. ft. per minute. Flow was regulated by calibrated, critical orifices placed between the impingers and a filter which prevented escape of live organisms to air—a vital precaution with pathogenic bacteria. With single impingers, flow rates up to 35 l. per minute, and consequent jet velocities up to 345 m. per second were possible. Two impingers used in series reduced the maximum air flow to 29.7 l. per minute.

C. Collection and count of impinger samples

Collection of particles: Particles were collected on glass discs (23 x 1.5 mm.). These were scrupulously clean and free from scratches. Metal spacers permitted separation from the orifice by 0.25–3.5 mm. In order to decrease the chance that particles would strike an area already filled by an organism and carom, exposure in the air stream was only long enough to collect about 5×10^4 particles.

Under these conditions and at optimum flow rates, the impinged deposit takes the form shown in figure 7. A central primary deposit, almost exactly the size of the orifice, is immediately surrounded by a clear space containing a few scattered organisms. This is, in turn, surrounded by a halo of impinged particles, which is sharply defined. Only occasional organisms appear beyond its limits. The density of the secondary deposit or halo is not uniform, as is shown in figure 8, in which the average density of individual strips is plotted as ordinate and the distance from the center of the deposit as abscissa. A smooth curve has been drawn through points obtained from two experiments. This, with the observation that particles were not impinged on cover slips fixed to the "roof" of the collector, suggests that deposition is essentially restricted to the area outlined in figure 7. Our confidence that estimated aerosol concentration

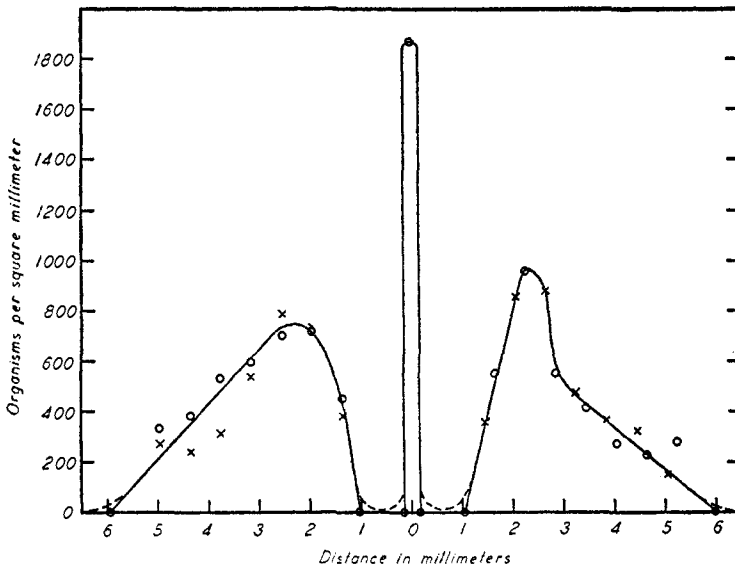

FIG. 8. Intensity of deposit in relation to lateral distance from orifice

based on impinger collection approximates an actual value rests primarily on this evidence and appears well founded.

Enumeration of impinger samples: The number of particles deposited was estimated from an average deposit density per square millimeter (derived from the count of representative strips at right angles to the jet) and the area of the deposit, determined by measurement and planimetry of a scale drawing thereof. The area times the density, divided by the total air flow, gave the number of particles collected per liter of air, a number directly comparable to that obtained photoelectronically.

Representative strips were defined by a slit eyepiece, and particles counted by means of dark-field illumination with a high-power dry lens. The length of each strip was measured with the aid of a mechanical stage; its width was deter-

mined by calibration of the eyepiece slit with a stage micrometer. The density of the particulate population per square millimeter was separately determined for each strip, and a mean density derived. This value multiplied by the area of the deposit yielded the total number deposited. From it, the particulate concentration per liter was obtained by dividing by the total air flow.

Particulate population, not only of the primary deposit but also of the right and left portions of the halo, was estimated separately. The ratios of the population of the jet deposit to that of the halo were not sufficiently constant to justify estimates based solely on counts of the former. But when two impingers were used in series, there was no statistically significant difference between these ratios as computed for first and second impingers. We believe that this supports the microscopic observation that particle size is approximately uniform.

Experiments did not indicate that total counts were markedly increased by coating slides with an alkyd resin adhesive. The density of the primary deposit appeared, however, to be slightly increased at the expense of that of the halo. Since coating tended to interfere with dark-field microscopy, it was abandoned.

D. Results

Single impingers: Results of a number of experiments performed with *B. globigii* aerosols using single impingers are graphically shown in figure 9, in which calculated jet velocity appears as abscissa and the counter/impinger count ratio as ordinate. The full line represents results obtained with slit jets; the broken line those derived with tapered jets. In the former case, maximum collection efficiency lies at velocities between 90 and 120 m. per second, and appears to be slightly more than 50 per cent. At velocities greater than 150 m. per second, efficiency rapidly diminishes.

The observations represented in figures 7, 8, and 9 suggest that impingement should be largely explicable in terms of microaerodynamics within the impinger. Comparison of the efficiency of tapered and slit jets suggests that turbulence favors impingement. Although the geometry of the deposit and the increased size of both clear space and halo at higher jet velocities are striking, we can only offer a qualitative explanation. This phenomenon, the less effective impingement of solid as compared with liquid droplets observed by Landahl (51) and May (61), and the reduction in collection efficiency when jet velocities exceed optimal values, can all be qualitatively explained by the assumption that these particles are elastic. Some of those striking the surface under the jet would bounce; of these, a fraction could be returned to the halo and adhere; some would be carried by the air stream and, as its velocity increased, would clear the slide. Many would be deposited elsewhere. The marked diminution of deposition observed at jet velocities above 150 m. per second might also be due to shattering of bacteria into very fine particles, not microscopically visible. But the relative importance of aerodynamic factors, elasticity of the particles, and shattering cannot yet be quantitatively evaluated.

Two impingers in series: Although impingers were occasionally used singly, rather more consistent data could be obtained when two collectors were placed

in series. Data representative of an experiment with two impingers in series appear in table 1.

The experimental conditions are given at the top of the table. Flow rates in liters per minute, determined by means of critical orifices, appear in the second column. Calculated jet velocities preceded by the numbers (1) and (2) refer to velocities at the first and second orifices, respectively. Spacer thickness, given in millimeters, indicates the distance between collecting slide and orifice. Under the heading "Concentration per liter, impinger," sets of three values

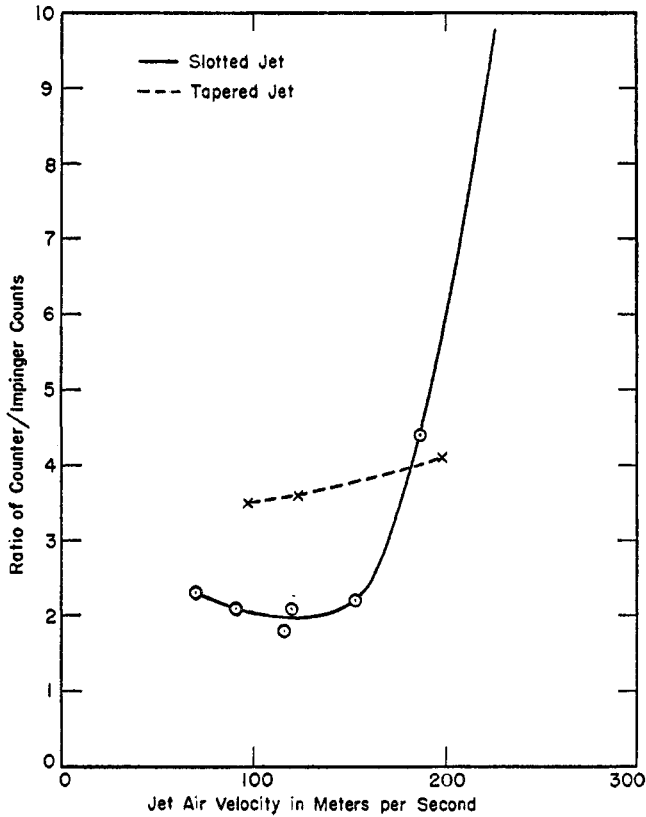

FIG. 9. Comparison of collection by single impingers with direct photoelectric measurement

generally appear. These sets of values from top to bottom denote successively the concentration derived from the first impinger deposit alone, from the second deposit, and from their sum. Figures in parentheses indicate an estimate with patently ineffective collection, and a single value is given where an impinger was used singly. "Concentration per liter, counter" refers to photoelectric enumeration. The ratios in the final column are usually paired; the upper value refers to the ratio between the electronic count and the number collected by the first impinger; the lower expresses the relation between counter value and the num-

TABLE 1
Comparison of impinger and photoelectronic counts

February 13, 1948

Conditions

Barometer (cor.), 765.6 mm. Dewpoint of atomizer air, Organism, *B. globigii* spores
Temperature: room, 24.5°C.; 16.8°C.; aerosol, 16.2°C. Concentration of suspension,
bath, 25°C. 1.6×10^8 cc.

RUN	FLOW RATE	CALCULATED JET VELOCITY	SPACER THICKNESS	CONCENTRATION PER LITER		RATIO COUNTER/ IMPINGER
				Impinger	Counter	
1.....	16.8	(1) 91	0.5	572	1360	2.4
		(2) 92		527		
				1099		1.2
2.....	16.8	(1) 91	0.5	707	1418	2.0
		(2) 92		367		
				1074		1.3
3.....	20.8	(1) 118	0.5	739	1462	2.0
		(2) 122		370		
				1109		1.3
4.....	20.8	(1) 118	0.5	626	1464	2.3
		(2) 122		334		
				960		1.5
5.....	20.8	(1) 118	1.0	570	1398	2.5
		(2) 122		304		
				874		1.6
6.....	20.8	(1) 118	1.0	605	1398	2.3
		(2) 122		331		
				936		1.5
7.....	25.2	(1) 149	1.0	478	1402	2.9
		(2) 168		(60)		
8.....	25.2	(1) 149	1.0	549	1320	2.4
		(2) 168		(69)		
9.....	16.8	(1) 91	2.0	477	1326	2.8
		(2) 92		245		
				722		1.8
10.....	16.8	(1) 91	2.0	474	1352	2.9

ber collected by two impingers in series. Where no second value is given, collection by the second impinger was either negligible or the deposit faulty.

Collection by the first impingers in replicate runs may differ by as much as 25 per cent, presumably owing to unpredictable changes in the air streams within

the impinger resulting from minute changes in the position of the collecting discs. The number of particles collected by two impingers in series in two replicate runs appears to differ less markedly. Indeed, the error is consistent with the expected sampling error ± 35 , when the count is about 1000.

In table 2 appear results derived from all experiments with *S. marcescens* as well as *B. globigii*, in which the light bulb was supplied by an 8-v. storage battery.

Ratios of concentrations determined photoelectronically and by the impinger method are given, including values for single impingers, for two in series, and a calculated value for 100 per cent collection by the impinger method. At the extreme right of the table, the values of the ratio indicate progressive diminution

TABLE 2

Comparison of aerosol concentrations determined photoelectronically and by impingement

SPACER THICKNESS (MM.)...		0.5			1.0	2.0	3.5
APPARENT VELOCITY	TYPE OF JET	RATIOS: $\frac{\text{PHOTOELECTRIC CONCENTRATION}}{\text{IMPINGER CONCENTRATION}}$					
		One impinger	Two impingers in series	Photoelectric Calculated	Single impinger		
(A) <i>B. globigii</i>							
<i>m./sec.</i>							
113	Slit	1.8				2.80	
118	Slit	2.1 \pm 0.23	1.4 \pm 0.14	1.1 \pm 0.10	2.40	2.70	(50)
149	Slit	2.2			2.70		
123	Taper	3.6	2.1	1.5			
(B) <i>S. marcescens</i>							
118	Slit	2.9	2.0				
149*	Slit	2.2	1.4	1.0 \pm 0.1			
233†	Slit	2.8					

* Velocity at second jet 169 m. per second.

† Velocity at second jet sonic.

of collection efficiency as the distance between slide and orifice increases. This confirms the observations of Bourdillon and others (10).

The calculated value rests largely on the theoretical conclusions reached independently by May (61) and Sell (78) and applied by La Mer and Hochberg (49) and Johnstone, Winsche and Smith (46) to the deposition of larger particles from slower air streams. May's data (61, fig. 7, p. 192) suggest that one may write impingement efficiency, I , as

$$I = \frac{\text{Number of particles impacted per liter of aerosol}}{\text{Concentration, particles per liter}} = \frac{N_i}{C_a} = f\left(\frac{\rho V D^2}{\eta l}\right)$$

where P denotes density, V is velocity in centimeters or meters per second, D is the particulate diameter in centimeters, η is the viscosity in poises, and l is

a linear dimension to which May and Sell attach different physical significance. The experimental conditions, including humidity, are such that ρ , η , and l are constant, so that we may write,

$$I = f(KVD^2)$$

Each bacterial species is approximately uniform in size, and although not spherical, we take D^2 as a characteristic constant dimension related to surface. May's data, moreover, suggest that I is nearly linear in KVD^2 over the range 25–75 per cent, or in KV , where D is constant. Consequently, since aerodynamic conditions are similar in both impingers, we write:

$$\begin{aligned} N_1 &= C_a K V_1 = N_0 I \\ N_2 &= (1 - C_a I) I V_2 / V_1 \end{aligned}$$

and solving

$$I = 1 - \frac{N_2}{N_1} \times \frac{V_1}{V_2}$$

The meaning of the symbols is unchanged, except that the subscripts refer to the first and second impingers, respectively.

For *B. globigii* $I = 0.51$ and $\sigma = \pm 0.07$, so that two impingers in series should remove 76 per cent of the suspended particles. Total concentrations may readily be calculated. Values for the mean value of the ratio

$$\frac{\text{Photoelectronic concentration}}{\text{Calculated concentration}} = \frac{C_p}{C_i}$$

appear in the fifth column of table 2. Since the impinger method appears likely to provide slightly low estimates of concentration, the value of the ratio

$$C_p/C_i = 1.1, \quad \sigma = 0.1$$

is very satisfactory. We believe that it implies that photoelectronic measurement of aerosol concentration is accurate when particle diameter is somewhat more than 0.7μ .

With *S. marcescens*, similar considerations lead to values of $K = 0.47$, 75 per cent collection efficiency for two impingers in series, and

$$C_p/C_i = 1.0, \quad \sigma = \pm 0.1$$

These values are, however, less certain than those for *B. globigii*, since the jet velocities of 150 and 170 m. per second, respectively, for the first and second jets may differ sufficiently to invalidate the assumption that collection is linear in the velocity. Moreover, the estimates of velocity are less accurate, since pressure head, on which they depend, is changing rapidly in this range. None the less, comparison of the calculated values for *B. globigii* and *S. marcescens* suggests that photoelectronic count is about 90 per cent complete with the smaller organism.

The values for impingement efficiency are lower than estimates derived from

the collection of similar droplets of methylene blue and glycerol by means of a cascade impactor (79). This is to be expected, since collection of liquid particles is more complete (51, 61). Moreover, these liquid droplets are more dense than the bacterial particles on which our estimates rest.

Recent preliminary observations suggest that the counter may be more readily calibrated. If light intensity is increased by gradually increasing filament voltage from 2.0 to 7.0 v., the counting rate increases rapidly at first, later approaching a limiting value. If the count per minute is indicated as ordinate and voltage as abscissa, the resulting curve is sigmoid. With *B. globigii* the limiting value appears to be reached when filament voltage is not over 5.5 v. With *S. marcescens* the count appears to be about 90 per cent complete at 6.5 v., and is not quite complete at 7.5 v.

III. THE DETERMINATION OF THE CONCENTRATION OF BACTERIAL AEROSOLS BY THE METHOD OF COLLECTION AND CULTURE, COMPARED WITH DIRECT PHOTO-ELECTRONIC COUNT

A. Introduction

The determination of the concentration of living bacteria in air has depended on their collection, subsequent culture, and enumeration of the colonies appearing in plate cultures. Although biological material can be collected by methods used with inanimate matter, care is necessary to avoid impairment of viability. The methods generally used depend either on (1) filtration (63), (2) electrostatic sampling (9, 56), (3) bubbling through a liquid, (4) impingement (10, 77), (5) centrifugation (92), or (6) some combination of these methods (53, 56, 64). Filtration appears unsatisfactory, since recovery of viable vegetative organisms is poor (77). Electrostatic sampling (9, 56) appears promising, but has not, as far as we know, been carefully compared with other methods. Application of other methods is such that collection is either directly on a solid culture medium (10, 56) or into a liquid, from which aliquots are taken for culture (64, 74, 77), mixed with molten agar, and poured into plates. In either case, colonies are counted after an appropriate period of incubation at a temperature suitable for the organism studied. When collection is initially in a liquid medium, the concentration of viable particles in the aerosol, but not necessarily of viable organisms, is derived as follows:

$$\text{Concentration, particles per liter} = \frac{\text{volume of sample (cc.)}}{\text{volume of aliquot (cc.)}} \\ \times \frac{\text{number of colonies in culture}}{\text{air flow (l./min.)} \times \text{period of sampling (min.)}}$$

If collection is directly on a solid medium, the term including volumes of sample and of aliquot is unnecessary. The relative collection efficiency of a number of typical devices has been compared by du Buy, Hollaender, and Lackey (14). One of these is an atomizer bubbler, devised by Moulton, Lemon, and Puck (64), in which the aerosol atomizes some of the collecting fluid. The mist generated

is collected by bubbling through fluid in a second reservoir. Although bacterial concentrations measured with it are generally higher than those obtained with other devices, this is attributed to fracture of clumps of organisms. Results with the air centrifuge were not consistent. Moreover, both Lemon (53) and Rosebury (77) have found that impinger-bubblers collect nearly as efficiently as the Moulton device and are much more convenient.

Provided suitable precautions, described in modern bacteriological texts, are observed, culture counts are accurate to about 5 per cent. The error depends on the population of the sample taken.

B. Comparison of the bacterial concentration derived by the method of collection and culture with direct estimation by photoelectronic count

It seemed that the method of collection and culture might be quantitatively appraised by comparison with the photoelectronic method, which directly measures the total particulate concentration of bacterial aerosols. Provided the bacterial aerosols were pure, and provided further that the ratio of viable organisms to the total number present, commonly termed the viability coefficient, were known, absolute collection efficiency could be estimated. Or, alternatively, it would at least be possible to follow changes in viability by comparison of the photoelectronic and biological counts. The methods used and the results attained are next discussed.

C. Methods

1. Photoelectronic counts were made according to procedures already indicated.

2. The determination of viability ratios is essential for this proposed comparison. The methods used are described in appendix B.

Collection and culture of airborne organisms was accomplished by the method described by Rosebury (77), with impinger-bubblers operating as critical orifices at an air flow between 2 and 2.5 l. per minute.

The orifice was immersed about 4 mm. below the liquid level and 5 mm. above the bottom of thick-walled Erlenmeyer flasks into which they were inserted. Although 25 cc. of collecting fluid and four drops of olive oil were placed in each flask before sterilization, fluid losses amounting to about 2 cc. occurred during this process and the course of a run. Losses and final liquid volumes were determined by weight differences. After collection, the concentration of organisms per liter of aerosol was estimated by pour-plate colony counts.

D. Results

Representative data appear in table 3, and include zero values for the controls. The captions are self-explanatory. The data presented serve to illustrate (1) the consistency of data obtained, (2) the fact that clumps are broken up during atomization, and (3) especially that no significant changes either in apparent or true viability coefficients occur during an experiment, despite repeated atomization in the refluxing atomizer used. A summary comparing estimates of total

TABLE 3
The viability of bacterial suspensions as affected by atomization
 April 9, 1948; organism, *S. marcescens*

A. SUSPENSION CHARACTERISTICS		
	Before experiment	After experiment
Particulate concentration in atomizer $\times 10^{-8}$	1.0	1.4
Concentration of viable organisms in atomizer $\times 10^{-8}$	0.6	0.9
Per cent organisms as doublets.....	60	46
Apparent viability (per cent).....	55	64
"True" viability (per cent).....	60	68

The collection of living organisms from bacterial aerosols

B. AEROSOL CHARACTERISTICS					
TIME OF SAMPLING, 2 MIN.; FINAL VOLUME OF COLLECTING LIQUID, 23 CC.					
Run	Flow rate	Volume of aliquot			Concentration of organisms per liter
		1.0 cc.	0.5 cc.	0.2 cc.	
		Number of colonies per plate			
		<i>l./min.</i>			
I.....	2.27 (control)	0	0	0	0
II.....	2.27	54	27	9	370
III.....	2.28	54	25	12	392
IV.....	2.28	49	25	10	363

TABLE 4

Comparison of particulate concentrations of bacterial aerosols estimated by biological methods and by direct photoelectronic count

<i>S. marcescens</i>				<i>B. globigii</i>					
DATE	RUN	CONCENTRATION: PARTICLES PER LITER		APPARENT COLLECTION EFFICIENCY	DATE	RUN	CONCENTRATION: PARTICLES PER LITER		APPARENT COLLECTION EFFICIENCY
		Biological	Direct				Biological	Direct	
				<i>per cent</i>					<i>per cent</i>
April 1, 1948	II....	535	1406	38	April 13, 1948	II....	775	2098	37
	III....	440	1654	27		III....	844	2020	42
	IV....	447	1728	26		IV....	982	2150	46
April 9, 1948	II....	370	1425	26	April 14, 1948	II....	911	2106	43
	III....	392	1518	26		III....	934	2064	45
	IV....	363	1555	23		IV....	896	1964	46
Mean				28	Mean				43

bacterial or particulate concentration of aerosols derived by the method of collection and culture with direct photoelectronic determinations appears in table 4.

Since no significant change in viability appeared to result from atomization, the mean values determined for the aqueous bacterial suspensions in the atomizer have been assumed to apply to organisms in the aerosol. These values are taken as 0.7 for *S. marcescens* and 1.0 for *B. globigii* spores. The total bacterial concentration, based on the biological method of collection and culture, can be obtained by dividing the viable count by the viability coefficient. With the counter, particulate concentration is directly obtained. Both values appear under the captions "Concentration: particles per liter." The subheadings "Biological" and "Direct" distinguish them. Since the evidence discussed in Section II (page 406) suggests that the photoelectronic counter completely enumerates *B. globigii* and *S. marcescens* to the extent of 90 per cent, we have termed the ratio of biological concentration to direct concentration, "apparent collection efficiency."

The values are consistent, though smaller than those calculated from the impingement of dead organisms with another device. This is not surprising, since aerodynamic conditions are different, the jet velocities (345 m. per second) are greater than optimal, and the mean distance from jet to impinging surface is excessive. Some bacterial breakage may occur as the result of impingement at sonic velocity. Its extent probably varies with bacterial species, but has not yet been determined.

The efficiency is, however, less than that estimated by Rosebury (77) for these organisms, using similar impingers. This discrepancy is not explicable in terms of excessively high particulate counts resulting from contamination by non-bacterial particles, nor is it likely to be due to impaired viability of atomized organisms. Rosebury's experimental arrangements were, however, so different that the discrepancy may well be attributed to differences in density and particle size.

DISCUSSION

The simple theoretical considerations of May (61) and Sell (78) permit comparison of impingement efficiencies derived from physical and biological measurement. When impingement efficiencies are identical, the jet velocities should be inversely proportional to the squares of representative diameters; at identical velocities, the ratio of squared diameters should equal that of the efficiencies, since $I = KVD^2$.

In table 5 we have collected appropriate values for jet velocity, V , diameter, D , and efficiency, I .

For example, the method of microscopic count shows that collection efficiency is 45 per cent with *S. marcescens* at 150 m. per second; with *B. globigii*, we estimate from table 2 and figure 9 that 45 per cent efficiency is attained at a velocity of about 88 m. per second. The velocity ratio is about 1.7.

We should expect impingement to be proportional to the surface of that part of the particle that comes in contact with the collecting medium. In the case of spheres, this is proportional to D^2 , where D is the diameter. But the bacterial particles, although symmetrical, are not spherical. For these ellipsoidal

particles, comparable values may be obtained if we calculate the diameter of the sphere of equivalent mass. This appears in the table under the heading "diameter." The assumed mean values for particulate diameters may, of course, differ somewhat from the true values. Tentatively basing comparison on the assumed dimensions of *B. globigii*, we have computed a diameter for a sphere equivalent to *S. marcescens* which will exactly accord with theory. This turns out to be 0.7 μ instead of 0.66 μ calculated from axes 0.6 μ and 0.8 μ .

But in a streaming medium particles tend to orient themselves so that the long axis is parallel to the line of flow. One would then expect the impinging surface and impingement to be proportional to the squares of the short axes of an ellipsoidal particle. Values based on this assumption appear under the heading "Short axis of ellipsoid." Agreement with the observed value is somewhat closer. It has, however, been shown that the counter values are 10 per cent low in the case of *S. marcescens*. The observed value for collection ef-

TABLE 5
Theoretical appraisal of impingement data

	MEAN DIAMETER <i>D</i> IN MICRA				PHYSICAL METHOD		BIOLOGICAL METHOD		
	Sphere of equivalent mass		Short axis of ellipsoid		<i>I</i>	<i>V</i>	<i>I</i>		<i>V</i>
	Un- corrected	Corrected	Un- corrected	Corrected	per cent	m./ sec.	per cent	per cent	m./ sec.
Organism:	<i>D</i>	<i>D</i> ²	<i>D</i>	<i>D</i> ²					
<i>B. globigii</i>	0.92	0.85	0.8	0.64	45	88	43	43	345
<i>S. marcescens</i>	0.66	0.44	0.6	0.36	45	150	28	25	345
Ratio $R = \frac{B. globigii}{S. marcescens}$	$R = 1.9$		$R = 1.8$		$1/R = 1.7$		$R = 1.5$		$R = 1.7$

ficiency should therefore be correspondingly reduced. The corresponding ratio turns out to be 1.7, in excellent agreement with theory.

Although this hypothesis seems attractive, our data are too scanty for definitive proof. Further study of the impingement, both of spherical particles, such as the sulfur particles described by La Mer (48), and of more elongated bacteria, should provide information that has theoretical and practical significance.

The theory of impingement is certainly incomplete in other respects. Indeed, the significance of the dimension, *l*, appearing in the denominator appears in doubt. May (61) relates it to slit width; Sell (78) to a dimension of the object on which impaction takes place. The former explanation appears unsatisfactory, since this dimension is directly related to jet velocity, and with the impinger used by us, Sell's explanation appears irrelevant. That it is not directly related to slit-to-slide distance has been indicated in table 2.

Further information is necessary concerning the influence of physical properties of the particle and the collecting surface such as elasticity, number and

orientation of charges, and "tackiness." The elasticity and friability of bacteria, both dead and alive, deserve further study.

Although the effect of long-range forces may well be more important, the effect of charge can be experimentally determined by coating slides with substances differing in this respect. Although particle size and also shape may, as suggested by Gucker and by Mueller (65), be determined by photoelectronic measurement of the intensity of light scattered at different angles, it should also be possible to estimate particle size with the present instrument from the relation between counting efficiency and intensity of the light source. Results must, however, be carefully interpreted, since Barnes and La Mer (7) have shown that the intensity of light scattered by particles is characterized by a function in which the exponent changes with the ratio of particle size to the wave length of the scattered light.

Empirical calibration may be easier by means of aerosols generated from the extraordinarily uniform sulfur sols prepared by La Mer (48). Such aerosols should also demonstrate the effect of changes in particulate refractive index on the intensity of scattered light. As the index is increased, it should be possible to count smaller particles accurately.

But even in its present form the photoelectronic instrument instantaneously provides information which can be obtained by other methods only after hours of meticulous and tedious observation. With improvements based on the use of more sensitive photocells and changes in the optical system, it should be possible to determine accurately the concentration of aerosols containing particles considerably smaller than 0.7μ in diameter, the present lower limit.

And even with this limitation, it is a useful tool for the rapid estimation of the concentration of dilute bacterial aerosols. It should be useful for calibrating methods for the collection of particulate matter from aerosols, for the determination of changes in viability, and in quantitative laboratory investigation of airborne disease, especially those concerned with penetration and dosage.

In conclusion, it should be emphasized that the counter is at present a laboratory instrument, that enumeration of particles smaller than 0.7μ is incomplete, and that it cannot be directly applied to determining the concentration of aerosols greater than 1000 particles per liter and therefore is not adapted for use in ambient air, which generally contains many particles. It is not sufficiently sensitive to detect and enumerate primary virus particles, some of which are only 0.01μ in diameter. Biological fluids are, however, rarely as dilute as 0.1 per cent. The particulate size of infectious particles may often be largely conditioned by the concentration of the solute in the fluid in which they are suspended. One might expect particles about 1μ in diameter to result from drops 10μ in diameter if concentration of the solute is only 0.1 per cent, assuming that the solute has a density of 1.0. This fact may extend the utility of the instrument.

Moreover, improvements which will materially decrease the lower limit of size and increase the limiting concentration at which counts are complete seem theoretically and practically possible. With improvements, it should be possible not only to count suspended particles but also to measure their size and approximately to describe their size and shape.

SUMMARY

1. Since it has long been suspected and it is now definitely established that disease may be airborne, it is not surprising that medical scientists have studied and clarified the understanding of aerosols.

2. Certain bacterial species may be grown so that size and shape are nearly uniform. The study of bacterial aerosols exemplifying suspensions containing solid particles of low density should therefore be profitable on physical-chemical grounds as well as for the elucidation of the mechanism of transmission of airborne disease.

3. Effective study of aerosols must be preceded by the generation of pure suspensions of particles of uniform size and shape, and by accurate measurement of their concentrations.

4. The photoelectronic instrument used in these studies is very briefly described.

5. A method of generating dilute bacterial aerosols is briefly presented.

6. Comparison of aerosol concentrations, determined by photoelectronic and impingement methods, suggests that direct measurement by the photoelectronic device is accurate provided (1) the diameter of the bacterial particle somewhat exceeds 0.7μ and (2) illumination is sufficiently intense.

7. The concentration of living organisms, determined by biological methods after collection with impinger-bubblers, is less than particulate concentration determined photoelectronically. Although this discrepancy arises in small part from the presence of non-viable organisms, it appears to be largely attributable to incomplete collection, presumably due to unfavorable conditions, possibly including breakage at the high impingement velocity used.

8. Impingement efficiency, as already shown by May and Sell, is proportional to particle density and surface. It is suggested that with ellipsoidal bacterial particles, presumably oriented in the air stream, the surface effective for impingement is determined by the magnitude of the shorter axis of the ellipsoid.

9. A quantitative theoretical description of impingement must also include the effect of other physical properties, such as elasticity and friability of the particle, the magnitude and distribution of charge both on the particles and on the collecting surface, as well as the microaerodynamics of the impinger.

10. Advantages and limitations of the photoelectronic instrument are indicated. Improvements should decrease the particle size at which accurate measurements are possible.

REFERENCES

- (1) *Aerobiology*, Publication No. 17, Forest R. Moulton, *Editor*, American Association for the Advancement of Science, Washington, D. C. Science Press, Lancaster, Pennsylvania (1942).
- (2) AITKEN, J.: *Collected Papers*. Cambridge University Press, London (1923).
- (3) ANDREWES, C. H., AND GLOVER, R. E.: *Brit. J. Exptl. Path.* **22**, 91-97 (1941).
- (4) DAUTREBANDE, L., HIGHMAN, B., AND ALFORD, W. C.: *J. Ind. Hyg. Toxicol.* **30**, 103-7 (1948).
- (5) BAKER, A. H. AND TWORT, C. C.: *J. Hyg.* **43**, 382-94 (1943).
- (6) BARNES, E. C., AND PENNEY, G. W.: *J. Ind. Hyg. Toxicol.* **18**, 167-72 (1936).
- (7) BARNES, M. D. AND LA MER, V. K.: *J. Colloid. Sci.* **1**, 79-91 (1946).

- (8) *Bergey's Manual of Determinative Bacteriology*, R. S. BREED, E. G. D. MURRAY, AND A. P. HITCHENS, *Editors*, The Williams & Wilkins Company, Baltimore (1948).
- (9) BERRY, C. M.: U. S. Pub. Health Repts. **56**, 2044-51 (1941).
- (10) BOURDILLON, R. B., LIDWELL, O. M. AND THOMAS, J. C.: J. Hyg. **41**, 197 (1941).
- (11) BROWN, C. E.: J. Ind. Hyg. **13**, 285-91 (1931).
- (12) BROWN, C. E.: J. Ind. Hyg. **13**, 293-313 (1931).
- (13) DU BUY, H., ARNOLD, F. A., AND OLSON, B. J.: U. S. Pub. Health Repts. **162**, 1391-1413 (1947).
- (14) DU BUY, H., HOLLAENDER, A., AND LACKEY, MARY D.: U. S. Pub. Health Service, Suppl. Pub. Health Repts. No. **184**, 1-40, U. S. Government Printing Office, Washington, D. C. (1945).
- (15) CHALLINOR, S. W.: J. Hyg. **43**, 16-54 (1943).
- (16) CHOPE, H. D. AND SMILLIE, W. G.: J. Ind. Hyg. Toxicol. **18**, 780-92 (1936).
- (17) DAUTREBANDE, L., HIGHMAN, B., AND ALFORD, W. C.: J. Ind. Hyg. Toxicol. **30**, 103-7 (1948).
- (18) DAUTREBANDE, L., ALFORD, W. C., AND HIGHMAN, B.: J. Ind. Hyg. Toxicol. **30**, 108-13 (1948).
- (19) DEBYE, P.: J. Phys. Colloid. Chem. **51**, 18-32 (1947).
- (20) DRINKER, C. K.: J. Ind. Hyg. **3**, 295-303 (1922).
- (21) DRINKER, P., AND HATCH, T.: *Industrial Dust*. McGraw-Hill Book Company, Inc., New York (1936).
- (22) DRINKER, P., THOMSON, R. M., AND FITCHET, S. M.: J. Ind. Hyg. **5**, 162-85 (1923).
- (23) DUGUID, J. P.: Edinburgh Med. J. **52**, 385-401 (1945).
- (24) DUGUID, J. P.: J. Hyg. **44**, 471-9 (1945-46).
- (25) DUNKLIN, E. W., AND PUCK, T. T.: J. Exptl. Med. **87**, 87-101 (1948).
- (26) EDWARD, D. G. F., ELFORD, W. J., AND LAIDLAW, P. P.: J. Hyg. **43**, 1-10 (1943).
- (27) EDWARD, D. G. F., LUSE, D., AND BOURDILLON, R. B.: J. Hyg. **43**, 11-15 (1943).
- (28) EDWARD, D. G. F., AND LIDWELL, O. M.: J. Hyg. **43**, 196-200 (1943).
- (29) ELFORD, W. J., AND VAN DEN ENDE, J.: J. Hyg. **44**, 1-15 (1945-46).
- (30) FINDEISEN, W.: Arch. ges. Physiol. (Pflügers) **236**, 367-9 (1935).
- (31) FINN, S. R., AND POWELL, E. O.: J. Hyg. **41**, 473-88 (1941).
- (32) FLÜGGE, C.: Z. Hyg. Infektionskrankh. **30**, 107-24 (1899).
- (33) GIBBS, W. E.: *Clouds and Smokes*. The Blakiston Company, Philadelphia (1942).
- (34) GRAESER, J. B., AND ROWE, A. H.: J. Allergy **6**, 415-20 (1935).
- (35) GREEN, H. L., AND WATSON, H. H.: Medical Research Council, Special Report No. 199, London (1935).
- (36) GREENBURG, L., AND SMITH, G. N.: U. S. Bur. Mines Repts. Invest. No. **2392** (1922).
- (37) GREENBURG, L., AND BLOOMFIELD, J. J.: U. S. Pub. Health Repts. **47**, 654-75 (1932).
- (38) GUCKER, F. T., JR., O'KONSKI, C. T., PICKARD, H. B., AND PITTS, J. N., JR.: J. Am. Chem. Soc. **69**, 2422-31 (1947).
- (39) GUCKER, F. T., JR., AND O'KONSKI, C. T.: Chem. Revs. **44**, 373 (1949).
- (40) GURNEY, S. W., WILLIAMS, C. R., AND MEIGS, R. R.: J. Ind. Hyg. Toxicol. **20**, 24-35 (1938).
- (41) GUYTON, A. C.: J. Ind. Hyg. Toxicol. **28**, 133-41 (1946).
- (42) HAMBURGER, M., JR., PUCK, T. T., AND ROBERTSON, O. H.: J. Infectious Diseases **76**, 208-15 (1945).
- (43) HATCH, T. F., AND KINDSVATTER, V. H.: J. Ind. Hyg. Toxicol. **29**, 342-6 (1947).
- (44) HEYMANN, B.: Zentr. ges. Hyg. Bakt. u. Immunitäts. **24**, 1 (1932).
- (45) JOHNSON, I., AND LA MER, V. K.: J. Am. Chem. Soc. **69**, 1184-92 (1947).
- (46) JOHNSTONE, H. F., WINSCHKE, W. E., AND SMITH, L. W.: Chem. Revs. **44**, 353 (1949).
- (47) LA MER, V. K., AND SINCLAIR, D.: OSRD Report No. 1857 (September 29, 1943) and Part V of OSRD Rept. No. 865 (September 4, 1942).
- (48) LA MER, V. K., AND BARNES, M. D.: J. Colloid. Sci. **1**, 71-7 (1946).
- (49) LA MER, V. K., AND HOCHBERG, S.: Chem. Revs. **44**, 341 (1949).

- (50) LANDAHL, H. D., AND BLACK, S.: J. Ind. Hyg. Toxicol. **29**, 269-77 (1947).
- (51) LANDAHL, H. D.: Personal communication.
- (52) LEHMANN, G.: J. Ind. Hyg. **17**, 37-40 (1935).
- (53) LEMON, H. M.: Proc. Soc. Exptl. Biol. Med. **54**, 298-301 (1943).
- (54) LISTER, J.: Brit. Med. J. **2**, 53-6, 101-2, 461-3, 515-17 (1868).
- (55) LOOSLI, C. G., ROBERTSON, O. H., AND PUCK, T. T.: J. Infectious Diseases **72**, 142-53 (1943).
- (56) LUCKIESH, M., HOLLADAY, L. L., AND TAYLOR, A. H.: Gen. Elec. Rev. **49**, 8-17 (1946).
- (57) LUCKIESH, M.: *Applications of Germicidal, Erythemat and Infrared Energy*. D. Van Nostrand Company, Inc., New York (1946).
- (58) MANSON, P.: J. Linnean Soc. London **14**, 304-11 (1879).
- (59) MASPERO, SIR G.: *Life in Ancient Egypt and Assyria*, p. 119. Chapman and Hall, London (1891).
- (60) MASTERMAN, A. T.: J. Hyg. **41**, 44-64 (1941).
- (61) MAY, K. R.: J. Sci. Instruments **22**, 187-95 (1945).
- (62) MIE, GUSTAV: Ann. Physik [4] **25**, 377-445 (1908).
- (63) MIQUEL, P.: *Les organismes vivants de l'atmosphère*. Gauthier-Villars, Paris (1883).
- (64) MOULTON, S., PUCK, T. T., AND LEMON, H. M.: Science **97**, 51-2 (1943).
- (65) MUELLER, HANS: Personal communication.
- (66) OSLER, SIR WILLIAM: *The Evolution of Modern Medicine*. Yale University Press, New Haven, Connecticut (1922).
- (67) OWENS, J. S.: Proc. Roy. Soc. (London) **A101**, 18-37 (1922); J. Ind. Hyg. **4**, 522-34 (1922).
- (68) PASTEUR, L.: *Memoire sur les corpuscules organismes qui existent dans l'atmosphère* (1862), *Oeuvres de Pasteur*, P. Vallery-Radot edition, Vol. 2, pp. 210-94. Masson et Cie, Paris (1922).
- (69) PERRIN, F.: J. Chem. Phys. **10**, 415-27 (1942).
- (70) PUCK, T. T.: J. Exptl. Med. **85**, 729-39 (1947).
- (71) PUCK, T. T., ROBERTSON, O. H., AND LEMON, H. M.: J. Exptl. Med. **78**, 387-406 (1943).
- (72) PULVERTAFT, R. J. V.: J. Hyg. **43**, 352-6 (1943-44).
- (73) RIEDEL, G.: Kolloid-Z. **103**, 228-32 (1943).
- (74) ROBERTSON, O. H., BIGG, E., PUCK, T. T., AND MILLER, B. F.: J. Exptl. Med. **75**, 593-610 (1942).
- (75) ROBERTSON, O. H., LOOSLI, C. G., PUCK, T. T., BIGG, E., AND MILLER, B. F.: Science **94**, 612-13 (1941).
- (76) ROOKS, R.: Am. J. Hyg. **30**, 7-10 (1939).
- (77) ROSEBURY, T.: *Experimental Air-Borne Infection*, Microbiological Monographs. The Williams & Wilkins Company, Baltimore (1947).
- (77a) ROSENBLATT, P., AND LA MER, V. K.: Phys. Rev. **70**, 385-95 (1946).
- (78) SELL, W.: Forsch. Gebiete Ingenieurw., Forschungsheft No. **347**, Berlin (1931).
- (79) SONKIN, L. S.: J. Ind. Hyg. Toxicol. **28**, 269-72 (1946).
- (80) STILLMAN, E. G., AND BRANCH, A.: J. Exptl. Med. **40**, 733-42 (1924).
- (81) TOLMAN, R. C., GERKE, R. H., BROOKS, A. P., HERMAN, A. G., MULLIKEN, R. S., AND SMYTH, H. DE W.: J. Am. Chem. Soc. **41**, 575-87 (1919).
- (82) TOLMAN, R. C., REYERSON, L. H., BROOKS, A. P., AND SMYTH, H. D.: J. Am. Chem. Soc. **41**, 587-9 (1919).
- (83) TOLMAN, R. C., AND VLIET, E. B.: J. Am. Chem. Soc. **41**, 297-300 (1919).
- (84) TOPLEY, W. W. C., AND WILSON, G. S.: *Principles of Bacteriology and Immunity*, revised by G. S. Wilson and A. A. Miles. The Williams & Wilkins Company, Baltimore (1936).
- (85) TOURANGEAU, F. J., AND DRINKER, P.: J. Ind. Hyg. Toxicol. **19**, 53-7 (1937).
- (86) TRILLAT, A.: Bull. acad. méd. (Paris) [3] **119**, 64-74 (1938).
- (87) TWORT, C. C., BAKER, A. H., FINN, S. R., AND POWELL, E. O.: J. Hyg. **40**, 253-344 (1940).

- (88) TWORT, C. C., AND BAKER, A. H.: *J. Hyg.* **44**, 451-63 (1945-46).
 (89) TYNDALL, JOHN: *The Floating Matter of Air in Relation to Putrefaction and Infection*.
 D. Appleton-Century Company, New York (1882).
 (90) TYNDALL, JOHN: *Phil. Mag.* [4] **37**, 384 (1869).
 (91) WATSON, H. H.: *Trans. Inst. Mining Metals (London)* **46**, 155 (1936).
 (92) WELLS, W. F.: *Am. J. Pub. Health* **23**, 58-9 (1933).
 (93) WELLS, W. F.: *Am. J. Hyg.* **20**, 611-18 (1934).
 (94) WELLS, W. F., AND STONE, W. R.: *Am. J. Hyg.* **20**, 619-27 (1934).
 (95) VAN WIJK, A. M., AND PATTERSON, H. S.: *J. Ind. Hyg. Toxicol.* **22**, 31-5 (1940).
 (96) WHYTLAW-GRAY, R., AND LOMAX, R.: *Smoke*, p. 186. Edward Arnold and Company,
 London (1932).
 (97) WILSON, I. B., AND LA MER, V. K.: *J. Ind. Hyg. Toxicol.* **30**, 265-81 (1948).
 (98) ZIMM, B. H., STEIN, R. S., AND DOTY, P.: *Polymer Bull.* **1**, 90-119 (1945).

APPENDIX A

B. globigii spores

For impinger studies, the spores were autoclaved 45 min. at 15 p.s.i. and sterility tests made. Suspensions were diluted with distilled water to give a final concentration of about 10^8 per cubic centimeter. For viability studies, autoclaving was omitted.

S. marcescens

This organism was grown for 18 hr. at room temperature in tryptic digest broth with 0.3 per cent dextrose added. Cultures were centrifuged, re-suspended in sterile distilled water, and allowed to stand overnight in the cold room. A second centrifugation was followed by re-suspension, 2-3 hr. standing, and final re-suspension in distilled water; if dead suspensions were desired, final re-suspension was in 0.5 per cent formaldehyde.

Total concentrations were determined by the method of direct count (84) in a Petroff-Hausser counting chamber on the day of use. Great care was taken to count individual organisms. Final concentrations were generally of the order of 10^8 per cubic centimeter.

The concentration of viable organisms was established by making appropriate dilutions, and counting colonies on pour plates.

APPENDIX B

Although direct determination of this ratio did not appear possible in terms of easily and rapidly measurable physical differences between living and dead organisms, indirect means of estimation did exist. Dunklin and Puck (25) have shown that at room temperature and humidity exceeding 60 per cent, the death rate of organisms in an aerosol is in terms of minutes and hours, not seconds. It therefore seemed reasonable to assume that under those atmospheric conditions viability would not change measurably as an organism passed from the atomizer to the collecting device. The time of transit is surely less than 3 sec. and probably less than 1 sec.

It remained to be shown that the viability of organisms was not reduced by atomization, although direct evidence is not now available. Supporting evi-

dence can be obtained by determining viability ratios on the liquid suspension used for atomization both at the beginning of an experiment and on the residual fluid remaining in a reflux atomizer at its conclusion. In this type of atomizer larger droplets, many of them containing bacteria, return to the fluid reservoir. Consequently, some bacteria must be atomized more than once. If the process is harmful, viability of the bacterial suspension would decrease demonstrably with time. The absence of change would suggest that (1) atomization did not alter viability, and (2) indirectly that it was permissible to assume the same viability coefficient for both suspension and aerosol. The following measurements were necessary:

(a) The concentration of viable organisms was determined by the pour-plate method, using an incubation period of 48 hr. The temperature was 37°C. for *B. globigii* and about 25°C. for *S. marcescens*.

(b) Direct bacterial counts were made in a counting chamber. In addition to the usual count, the proportion of organisms occurring singly or in clumps was carefully observed. Moreover, the number of clumps containing two, three, or more organisms was separately recorded. Estimates of total bacterial concentration were computed in the customary manner.

Apparent viability coefficients presumably represent true coefficients only when a bacterial suspension is composed of single organisms. When clumps occur, the number of colonies appearing in plate cultures depends on the combined number of single particles and clumps. In the case of suspensions containing only single organisms and doublets, as with *S. marcescens*, it is possible to compute the viability ratios provided the proportion of organisms occurring singly and the apparent ratio are known. From these data, together with customary probability considerations, and the assumption that the probability of viability is the same for each cell whether it be single or in a doublet, one can readily derive the equation

$$V^2 - \frac{2V}{D} + \frac{2R}{D} = 0$$

in which B denotes the true and R the apparent viability ratio, and D the proportion of cells observed as doublets.

With *B. globigii* spores such treatment is not convenient, since more than four organisms frequently appear in a clump, and equations of higher degree result. Moreover, these spores are highly resistant and the assumption of 100 per cent viability is consistent with the observed number of colonies and the apparent viability ratios.