

THE AZULENES

MAXWELL GORDON¹

Imperial College of Science and Technology, London S.W.7, England

Received June 20, 1951

CONTENTS

I. Introduction and nomenclature.....	127
II. Isolation and structure of azulenes.....	130
III. Syntheses of azulenes.....	140
A. From cyclodecadione.....	140
B. Ring-expansion methods of synthesis.....	141
1. Diazoacetic ester method.....	141
(a) Substituted azulenes.....	142
(b) Benzazulenes and hydrobenzazulenes.....	151
(c) Azulenecarboxylic acids.....	155
2. Demjanow ring expansion.....	156
3. Diazomethane ring expansion.....	158
C. Azulene syntheses from cycloheptanone.....	159
D. Azulene syntheses from cyclopentanone.....	161
E. Azulene syntheses from natural products.....	163
F. Dehydrogenation procedures.....	166
G. Migration of substituents on the azulene nucleus.....	168
H. Rearrangement of azulenes to naphthalenes.....	169
I. Azulenes with functional groups.....	170
J. Table of azulenes.....	171
IV. Properties of azulenes.....	171
A. Chemical behavior of azulenes.....	171
B. Physical properties of azulenes.....	182
C. Pharmacology of azulenes.....	184
D. Spectra of azulenes.....	185
1. Visible spectra.....	185
2. Ultraviolet spectra.....	192
3. Infrared spectra.....	194
V. References.....	195

I. INTRODUCTION AND NOMENCLATURE

Observations of a blue color in certain essential oils, after certain simple operations such as distillation at atmospheric pressure, treatment with acids or oxidizing media, steam distillation, and similar processes which could result in dehydrogenation, have appeared in the literature for the past five hundred years.

Semmler (174) described about twenty different oils with this behavior, among which were the oils of camomile, yarrow, and cubeb. It was estimated in 1936 (109) that of the 260 essential oils for which descriptions were available, about 20 per cent contain azulenes or azulene precursors. Sabetay (170) devised

¹ Present address: Isotope Laboratory, E. R. Squibb & Sons, New Brunswick, New Jersey.

a color test for azulenogenic sesquiterpenes (see page 129), using bromine in chloroform as the reagent. The following essential oils gave blue, green, or violet colors with this reagent: araucaria, Copaiba balsam, freshly distilled cade, cajeput, calamus, camomile, cubeb, elecampane, elemi, *Eucalyptus globulus*, galangal, galbanum, ginger, hops, guaiac wood, juniper berries, geranium, lemon grass, milfoil, certain mints, lovage, myrrh, niaouli, black pepper, pimenta, rose distillate, Siam wood, valerian, ylang-ylang, and Zdravetz.

Later Müller (94) developed a reagent containing *p*-dimethylaminobenzaldehyde; of the 195 essential oils tested with this reagent, almost half were found to contain azulene precursors.

The generic name "azulene" was first applied to these blue oils by Piesse (113) in 1864. Later, when the structure had been elucidated (109), the name "azulene" was also given to the parent compound of the azulene series, $C_{10}H_8$ (I or Ia).

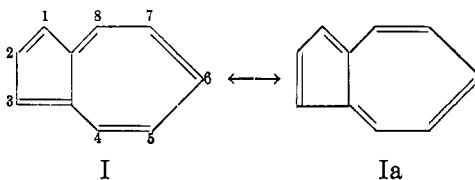

For the fully hydrogenated azulene the name "bicyclo[0.3.5]decane," according to Baeyer, has been used with the numbering shown in formula II. Treibs (196a) has proposed the numbering shown in formula IIa for decahydroazulene, and this system has the advantage of corresponding to the azulene numbering (see formula I).

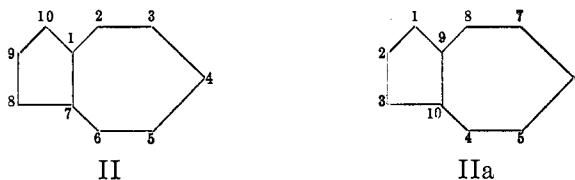

In recent issues of *Chemical Abstracts* the general properties of these compounds are indexed under the heading "Azulene." However, derivatives are indexed under "Cyclopentacycloheptene." For example, the compound with the structure III would be indexed as "Cyclopentacycloheptene, 6-isopropyl-4,8-dimethyl-."

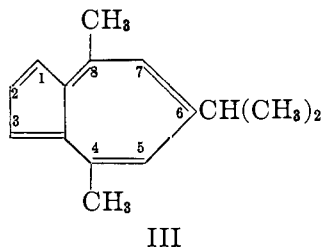

It is perhaps unfortunate that the name "azulene" has been applied to designate the parent compound, $C_{10}H_8$ (I), as well as the entire group of blue substances containing the fully dehydrogenated cyclopentacycloheptene nucleus. To avoid confusion, the term "azulene" will be used here in its *generic* sense, qualifying it by a name or formula whenever a specific compound is referred to.

The azulene field has been the subject of numerous review articles (5, 26, 44, 47, 49, 61, 97, 153), but no comprehensive recent reviews are available. The azulene literature is covered in this review essentially up to January 1, 1951, with some unpublished work also included.

In some instances azulenes found in nature have been named by prefixing part of the name of the essential oil to the word "azulene." Thus, the azulene from guaiol has been called guaiazulene, that of vetiver oil has been called vetivazulene, etc. Often, as the means of characterizing azulenes developed, several different essential oils were found to give the same azulene; in cases where different names had been applied the most recently given names were dropped, and all azulenes identical with, for example, guaiazulene, are now called by that name. These developments will be taken up at greater length in the next section. In many cases the blue oils isolated were not characterized and no specific names were given to the azulenes obtained.

To give a partial list, azulenes have been obtained, usually by dehydrogenation of the sesquiterpene fractions, from *Alpinia japonica* Miq. (70), Amyris oil (176), aromadendrene (from *Eucalyptus globulus* Labill.) (99, 109, 155, 197), *Artemisia arborescens* (105), *Asarum caudatum* (24), cajeput oil (from leaves of *Melaleuca leucadendron* L.) (188), calamus oil from the bark of *Acorus calamus* L. (182a), callitris oil (10), camomile oil (*Matricaria camomilla* L.) (40, 54, 68, 75, 109, 162, 167, 217), caucal oil and isocaucal oil (92), costus root (*Saussurea lappa* Clarke) (98, 201), the deep blue fraction of cottonseed oil (154a), cubeb oil (*Cubeba officinales* Miq.) (40, 167, 176), 1- α -curcumene (from rhizomes of *Curcuma aromatica*) (25), *Dacrydium kirkii* (21), black dammar resin (from *Canarium strictum* Roxb.) (93), gurjun balsam oil (*Dipterocarpus* Gaertn.) (53, 109, 175, 176), oil of *Drymis colorata* (89), West Indian elemi oil (*Elemi occidentale* from *Amyris elemifera*) (162, 179), *Eucalyptus globulus* oil (174), *Evodia littoralis* (80), *Ferula jaeschkeana* Vatke (14), *Geijera salicifolia* and *Geijera parviflora* (107), geranium oil (174), guaiol (wood of *Guaiaecum officinale* L.) (5, 162, 167, 207), kessyl oil (*Valeriana officinalis* L.) (10, 162, 196a), Ledum camphor from oil of *Ledum palustre* L. (73, 77, 103, 176), *Libocedrus bidwillii* (15), lime oil (*Citrus medica* L. var. *acida* Brandis) (41), roots of *Lindera strychnifolia* Vill. (78), *Lippia adoensis* Hochst. (104), myrrh (gum resin of *Balsamodendron myrrha*) (40, 199), orange agaric (*Lactarius deliciosus*) (69, 211-214), parthene oil (from guayule, *Parthenium argentatum*) (45), patchouli oil (*Pogostemon patchouli* P.) (40, 109, 181, 196), pelargonium oil (13), Weymouth pine (*Pinus monticola*) (82), *Podocarpus dacrydioides* (61), pyrethrum (171), Bulgarian rose oil (*Rosa damascena*) (38), rosewood oil (*Dysoxylon fraseranum*) (106), sagapenum (Persian Umbellifera) (200), oil of sarsaparilla root (177), shairol (from roots of *Ferula pyramidata*) (71, 72), *Skimmia laureola* Hook. fil.

(210), tetrahydroalantolactone (from root of *Inula helenium* L.) (163), Java vetiver oil (*Vetiveria zizanioides*) (5, 39, 161, 174, 179), oil of *Vitex negundo* L. (64), *Wintera colorata* (89), wormwood oil (*Artemisia absinthium* L.) (40, 95, 186), yarrow (*Achillea millefolium*) (11, 40, 74, 79, 167,) oil of Ytop (166), Zdravetz oil (*Geranium macrorrhizum*) (96, 109), zierone (18), *Artemisia kryloviana* (36), and *Juniperus scopulorum* (82). Finally, it is of interest that recently Prelog and Vaterlaus (154b) isolated 20 mg. of vetivazulene from the neutral lipid fraction of 160,000 liters of pregnant mares' urine, representing a concentration factor of the order of 10^{-10} .

Most of the azulenes obtainable from natural products have the empirical formula $C_{15}H_{18}$ and are isopropylidimethyl derivatives. Azulenes have also been isolated from the neutral fraction of lignite oil (53, 159), as by-products of acetylene polymerization (84, 156, 172), and from the pyrolysis of hydrocarbons (173).

The parent compound, azulene, $C_{10}H_8$, has been obtained in small amounts by the dry distillation of calcium adipate (52, 169). Plattner and Pfau (143) have proposed the following mechanism for this reaction:

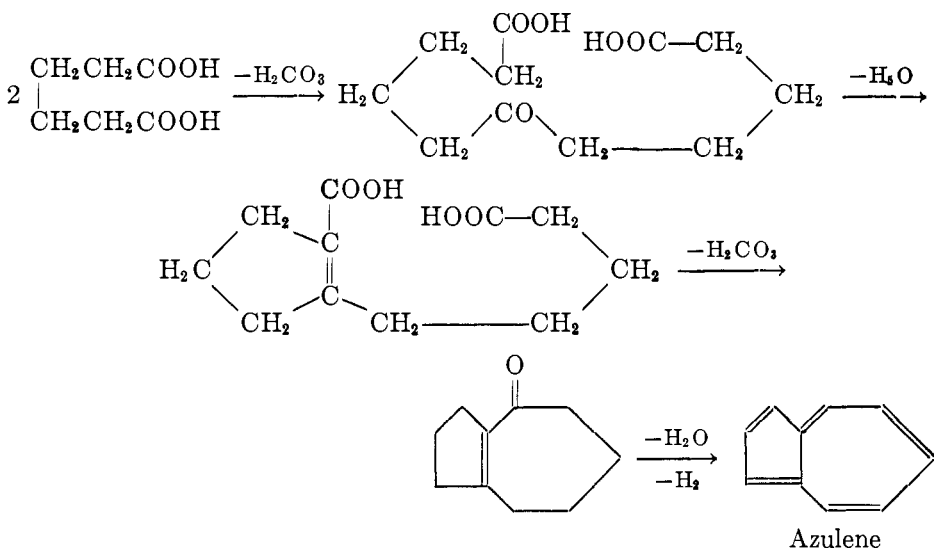

Azulene itself has also been isolated from tobacco smoke by Ikeda (63) and from caucal oil by Mitui (92). These are the only instances of its occurrence in nature or of its formation from natural products by dehydrogenation. The azulene obtained by Reppe (156) from acetylene has also been identified as the unsubstituted hydrocarbon, $C_{10}H_8$.

II. ISOLATION AND STRUCTURE OF AZULENES

One of the most striking properties of the azulenes is their intense blue or blue-violet color, noticeable even at very high dilution. The similarity of the color of some of the azulenes to that of a solution containing cupric ions explains

the early belief that the blue color of azulene was due to contamination of the distillate from the copper apparatus. This view was finally abandoned when it was shown that the blue substance was relatively volatile and accompanied the sesquiterpenes on distillation. It should be noted that the $C_{15}H_{18}$ azulenes boil appreciably higher than the sesquiterpenes. The azulenes codistil readily with the sesquiterpenes, however, and therefore color the $C_{15}H_{24}$ fractions deep blue. The bulk of the azulenes distil at approximately the temperature of the $C_{15}H_{25}OH$ fractions.

Semmler (174), who reviewed the earlier literature on this subject, considered it striking that a molecule of so low a boiling point should be so highly colored. He suggested that azulene consisted of two sesquiterpene residues (combined in the manner of indigo), which dissociated to colorless fragments in the gas phase and recombined in the liquid phase. This belief persisted in the literature until quite recently, when it was shown by a rigorous structure proof that azulene is a monomer (109).

The first great step in the elucidation of the hydrocarbon nature of azulenes (before these investigations the azulenes were believed to contain oxygen) was taken by Sherndal (176), who found that azulenes could be dissolved in concentrated mineral acids and reprecipitated unchanged by dilution with water, thereby effecting separation from most of their contaminants. Using this method Sherndal isolated the colored component of cubeb oil in a pure form and determined its empirical formula to be $C_{15}H_{18}$.

The low molecular weight of this compound was anticipated from its relatively low boiling point, and these results conclusively demonstrated the relationship between azulenes and sesquiterpenes. The azulene purified by the mineral acid route gave a crystalline addition compound with picric acid, and the empirical formula postulated was later shown to be correct. Sherndal believed the azulene from cubeb to be a tricyclic compound, since it took up four molecules of hydrogen, and therefore postulated IV to be the structural formula.

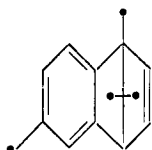

IV

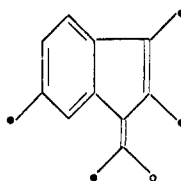

IVa

Later Kremers (79), using the Sherndal method, isolated an azulene in 1.5 per cent yield from yarrow oil. Both Kremers (79) and Augspurger (11) were able to prepare a decahydroazulene, $C_{15}H_{28}$, by catalytic hydrogenation with palladium; hence a bicyclic formula was proposed. Kremers assigned formula IVa to the azulene from yarrow, since its properties were similar to those of fulvene, and acetone and a phthalic acid homolog were thought to be ozonolysis products.

Ignoring the fact that the identification of the oxidation product of azulene was not sound, it was obvious from the relationship between color and constitution that a compound of type IV could not be colored, let alone blue. It was also evident that a compound like IVa, that is, an alkylated benzofulvene, could not be blue, inasmuch as the dimethylbenzofulvene (V) prepared by Courtot (30) is only light yellow. That further substitution of benzofulvene by three methyl groups could have no effect on the color is evident from the fact that

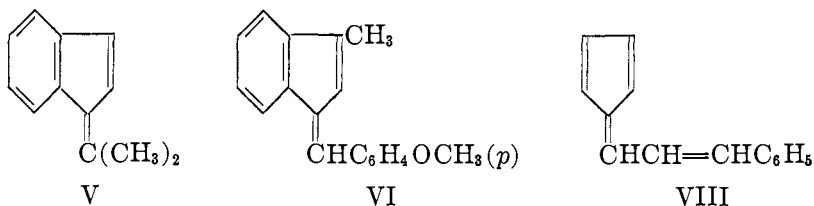

fulvene substituted by a relatively strong, color-intensifying group like *p*-anisylmethyl (VI) has only a yellow color (192). Styrylfulvene (VII) (191) is the simplest fulvene to possess a red-blue color.

Ruzicka (167) attempted to carry the structural investigation of azulenes further by studying the oxidation products of partially hydrogenated azulenes, since azulenes themselves gave only small inconclusive fragments on ozonization, but these results were also inconclusive. He found that azulenes were decomposed by permanganate, even at low temperatures, to small fragments and therefore concluded that there is no aromatic (six-membered) ring in the azulenes.

Reduction of azulene with sodium amalgam or sodium in amyl alcohol gave a hydrocarbon, $C_{15}H_{24}$, which was isomeric with the sesquiterpenes. It differed from the sesquiterpenes in that it reacted with sulfur at $180^\circ C$. more quickly and more vigorously to give a blue distillate, identical with the starting azulene (167). Oxidation of the hexahydroazulene gave no distinct large fragments.

By this time, utilizing melting points and mixed melting points of derivatives and visible spectra, the number of different, known, naturally occurring azulenes had been greatly reduced. Thus *S*-guaiazulene (from guaiol dehydrogenated with sulfur) was found to be identical with eucazulene, gurjunazulene, and the azulenes from geranium and patchouli oils. The different nature of *Se*-guaiazulene was believed to be due to migration of a methyl group, probably from the 1- to the 2-position (see Section III, G), since dehydrogenation with selenium is carried out at a higher temperature than with sulfur. Both *S*- and *Se*-guaiazulene undoubtedly originate from the same sesquiterpenes.

Later vetivazulene was found to be identical with elemazulene (118, 179). Chamazulene may be found to be identical with lactarazulene, and both are undoubtedly isomeric with gauiazulene.

At the present time only two different $C_{15}H_{18}$ azulenes, obtainable from natural sources without rearrangement, have had their structures proved beyond any reasonable doubt: namely, guaiazulene and vetivazulene. This small number is not surprising, inasmuch as application of the farnesol rule to the azulenes

indicates that only five isopropylidimethyl azulenes derivable from sesquiterpenes are theoretically possible. This subject will be considered in detail later.

Kremers (79) assigned the formula $C_{15}H_{28}$ to the fully hydrogenated azulene from cubeb on the basis of the volume of hydrogen taken up, yet this product had the same physical properties as Sherndal's octahydroazulene from cubeb, $C_{15}H_{26}$ (176). This led to some confusion early in the work, until it was realized that the similarity was accidental and that one double bond was difficult to hydrogenate. The molecular refraction showed octahydroazulene to be bicyclic with one double bond, thus supporting the results of investigators who claimed to have prepared a decahydroazulene.

In addition to the sulfuric acid procedure mentioned earlier, other methods have been employed to isolate azulenes from natural sources. Thus, the complex of azulenes with ferrocyanic acid, later decomposed by alkali, has been used (53, 159). The most important procedure developed for isolation and purification of azulenes was that of Pfau and Plattner (109), using chromatography on Brockmann alumina (22). These investigators also found that the trinitrobenzene complex of the azulenes was superior to the picrate or styphnate, and it was further found that the complex could be conveniently decomposed on alumina, the trinitrobenzene remaining at the top while the azulene was relatively easily removed from the column in most cases. These developments played an important role in the final elucidation of the structure of many azulenes, since they afforded relatively pure products for which characteristic spectra could be obtained.

Prior to the work of Pfau and Plattner (109), who succeeded in determining the structure of azulene and demonstrating it by synthesis, the best statement of the nature of the azulenes was made by Ruzicka and Rudolph (167) in 1926. These investigators concluded that azulene must contain a hitherto unknown bicyclic ring system which does not include a six-membered aromatic ring and which must be related to the sesquiterpenes.

The relationship of the azulenes to sesquiterpenes was very important and offered a significant clue to the structure of the azulenes (109). Thus, an isomer of cadalene was obtained, together with azulene, on the dehydrogenation of guaial with hydrogen iodide and phosphorus. Another cadalene isomer was obtained from vetiver oil. These naphthalene hydrocarbons were identified because they had been previously synthesized by Ruzicka in another connection (160).

The compound obtained from the rearrangement of guaial was 6-isopropyl-1,4-dimethylnaphthalene (VIII), and that from vetiver oil was 7-isopropyl-1,5-dimethylnaphthalene (IX). Study of the sesquiterpenes showed that a seven-membered ring was present and a five-membered ring was probable, and the structure of the azulene nucleus was confirmed by synthesis (109, 143). Putting all of the facts together it seemed that a retropinacol type of rearrangement had taken place. It is of interest in connection with these rearrangements that Pfau and Plattner (109) obtained naphthalenes on heating azulenes over silica gel at 300°C . in a vacuum.

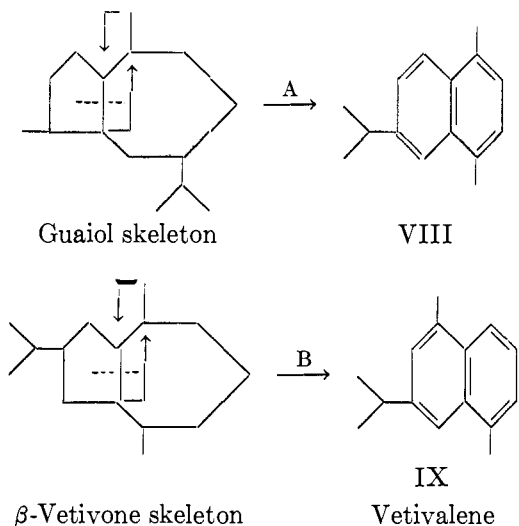

Also obtained in the dehydrogenation of vetiver oil was eudalene, 7-isopropyl-1-methylnaphthalene, resulting from rearrangement B (above) by loss of the migrating methyl group.

It was further found that hydrogenation of optically active β -vetivone gave an inactive dihydro- β -vetivone, which must be an internally compensated meso form, i.e., dihydro- β -vetivone must be symmetrical and have a structure as given in formula X (111, 112).

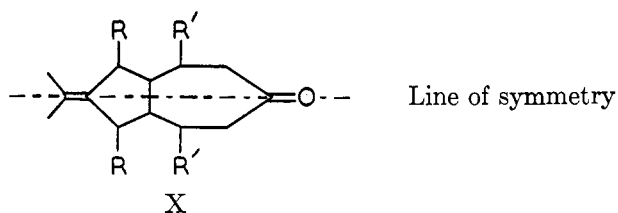

Applying the isoprene rule and considering the substituted naphthalene obtained, dihydro- β -vetivone must have formula XI and vetivazulene must have formula XII. The structure of vetivazulene has been confirmed by syn-

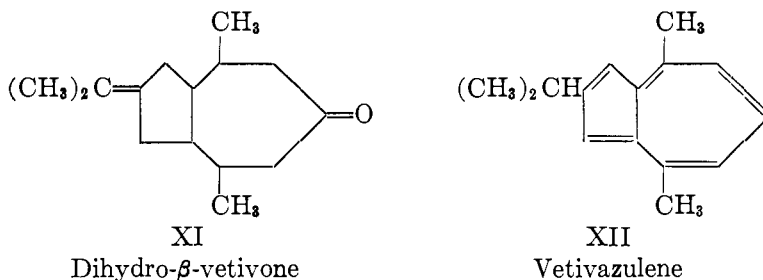

thesis (27, 110), that is, a product identical with vetivazulene has been synthesized. In view of the fact that the diazoacetic ester method was used, the synthesis can perhaps not be cited as alone proving the structure unequivocally. However, judging from past experience, the diazoacetic ester synthesis seems to be unequivocal for the synthesis of azulenes unsubstituted in the 5-, 6-, and 7-positions (see Section III, B, 1). The structure of dihydro- β -vetivone was further shown by degradation, *via* XIII and XIV, to XV, which was shown to be identical with a synthetic product (109).

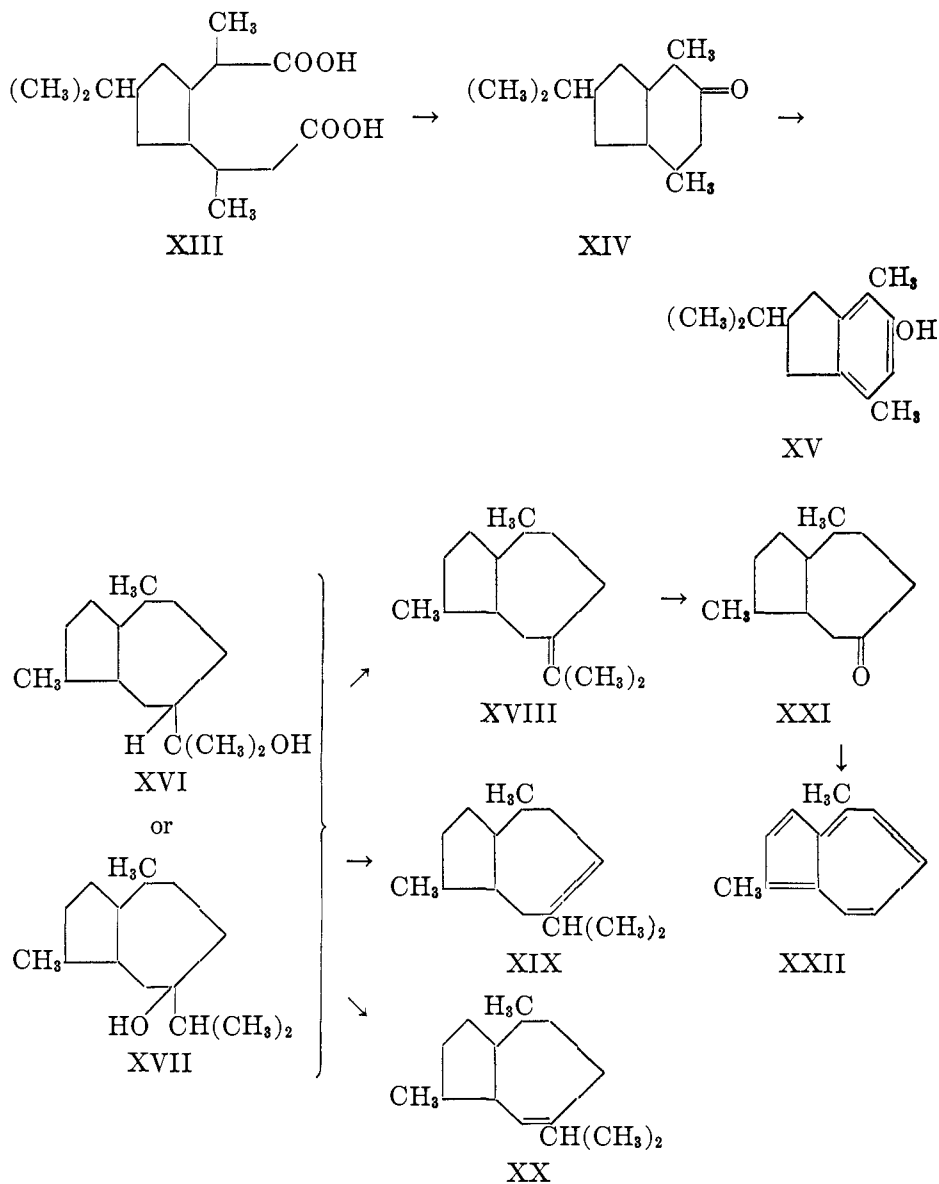

In determining the structure of guaiazulene (139), the dihydrosesquiterpene was again of value. The two possible structures of dihydroguaiol are XVI and XVII. Dehydration could give XVIII, XIX, or XX. However, degradation gives a ketone (XXI) from which an azulene can be obtained which is identical with synthetic 1,4-dimethylazulene (XXII) (see page 135).

Therefore the structure of guaiazulene was certain, except for the position of the isopropyl group. The isoprene rule allows three possibilities—XXIII, XXIV, and XXV—of which only XXIII and XXIV could undergo a retro-pinacol rearrangement to 6-isopropyl-1,4-dimethylnaphthalene (VIII).

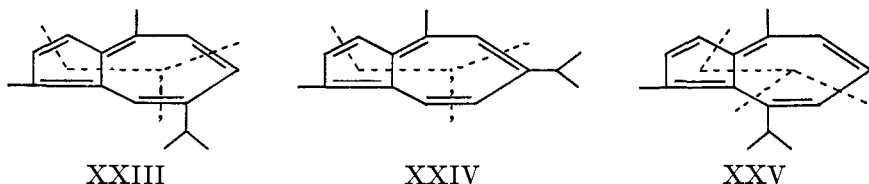

Structure XXIII was considered the most probable by Plattner (139), and was later proved by a synthesis of guaiazulene (127, 128). It should be noted at this point that while the synthesis of a product shown to be identical with guaiazulene has been achieved, the synthesis is not unequivocal enough to be cited conclusively as proof of structure, and another simpler, more direct, synthetic procedure is to be desired (127). The visible spectrum of guaiazulene was of great value in confirming the position of the isopropyl group, as was the oxidation of guaicol and its subsequent conversion to cadalene (140).

Reaction of the ketone XXI with isopropylmagnesium bromide gives a product which splits out water easily to give dihydroguaiene. Since water is difficult to split out from guaicol itself, the hydroxyl group is shown not to be in the ring (141); hence dihydroguaicol has structure XVI.

Guaiazulene was first crystallized by Birrell (16, 17). This investigator obtained no depression in a mixed melting point of his *S*- and *Se*-guaiazulenes. Probably he dehydrogenated with selenium at a sufficiently low temperature to avoid significant migration of the 1-methyl group.

Herzenberg and Ruhemann (53) believed that in the formation of azulenes from sesquiterpenes deep-seated changes in the skeleton, with formation of new rings, resulted. This postulate was supported by the fact that Ruzicka and Haagen-Smit (162), from pure guaicol, obtained two different azulenes on dehydrogenation with sulfur and with selenium. Today it is known that, as mentioned earlier, *Se*-guaiazulene (XXVII) results from *S*-guaiazulene (XXVI) by

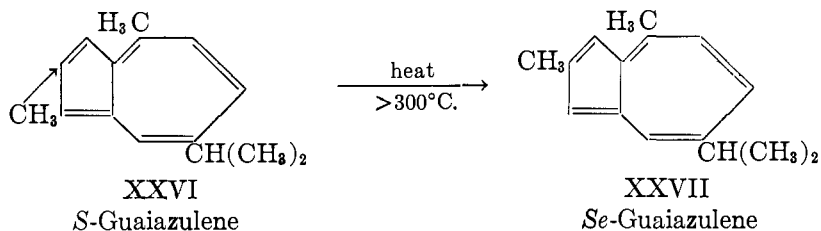

migration of a methyl group from the 1- to the 2-position at the higher temperature of the selenium dehydrogenation, and *S*-guaiazulene definitely contains the skeleton of guaial. The migration illustrated below is not uncommon in aromatic compounds (see Section III, G).

Dehydrogenation of terpenes to aromatic hydrocarbons has long been a valuable method for the elucidation of their structure (164, 165, 168). For example, the conversion of linear sesquiterpenes to naphthalenes can follow three theoretically possible paths, if the isoprene rule is observed (168).

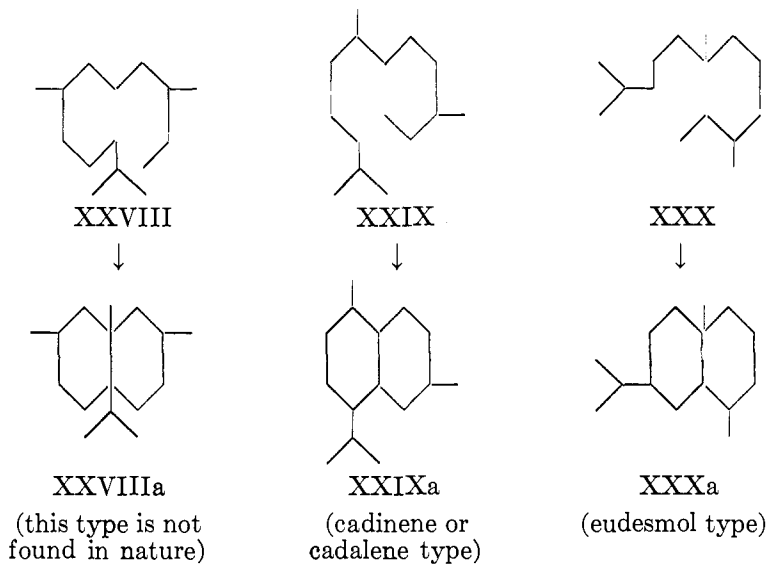

The analogous ring formation to substituted cyclopentanocycloheptanes (bicyclo[5.3.0]decanes) gives nine possible structures. These may or may not all exist in nature (109).

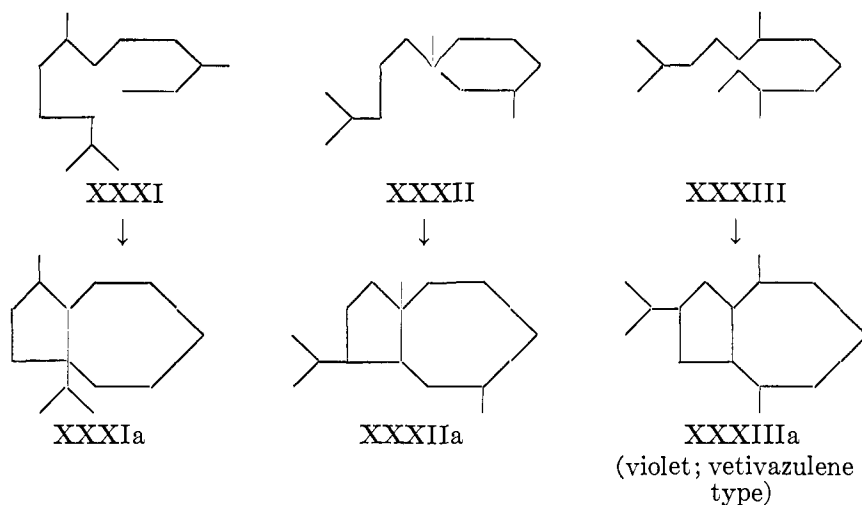

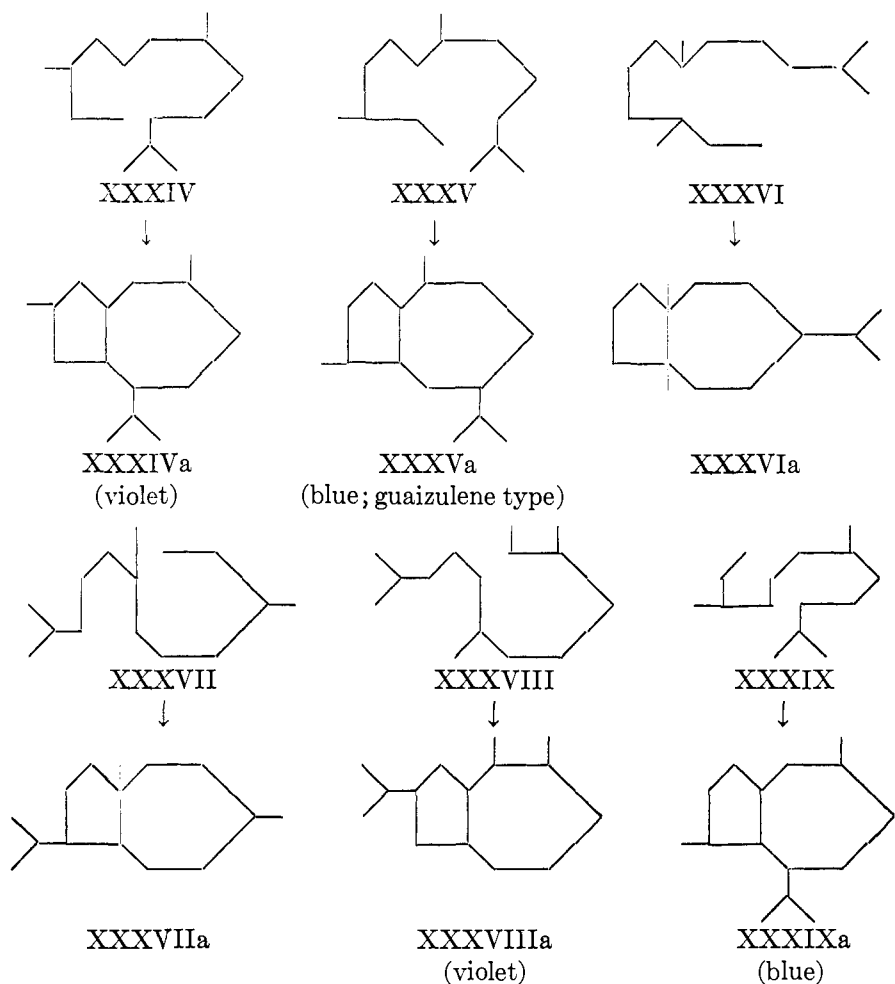

Structures XXXIa, XXXIIa, XXXVIa, and XXXVIIa cannot give $C_{16}H_{18}$ azulenes, since the angular alkyl groups make conjugated unsaturation impossible. Hence there is a maximum of five isopropylidimethylazulenes derivable from sesquiterpenes. Of these only XXXVa and XXXIXa are unsubstituted in the 2- and 6-positions and therefore would be pure blue in color (see Section IV, D, 1). Since XXXVa is of the guaiazulene type, it is likely that both chamazulene and lactarazulene have the skeleton of XXXIXa.

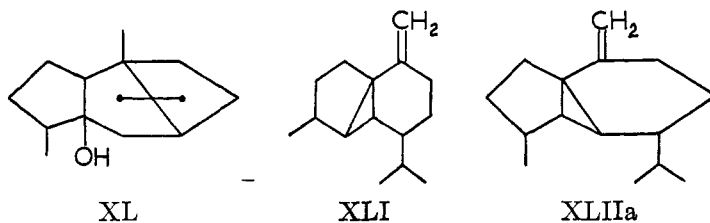

Certain tricyclic sesquiterpenes have also been found to give azulenes on dehydrogenation. Thus, patchouli alcohol (XL) (196), aromadendrene (XLI) (XLII) (197), and ledol (XLIII) (76, 77) all give guaiazulene on dehydrogenation.

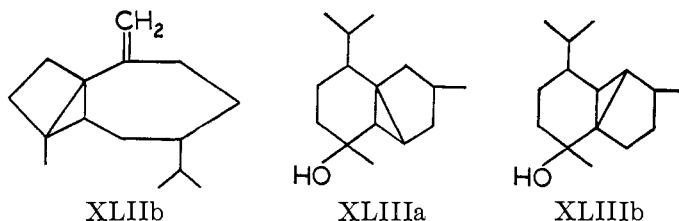

As indicated earlier, a number of naturally occurring azulenes do not have the usual $C_{15}H_{18}$ empirical formula. Thus, pyrethazulene (171) has the composition $C_{13}H_{14}$ and is believed to be 2,4,8-trimethylazulene, since its absorption spectrum is very similar to that of vetivazulene. An interesting azulene was isolated by Willstaedt (211, 212, 213, 214) from the orange agaric (*Lactarius deliciosus* L.). This compound, lactaroviolin, is red-violet and has the formula $C_{15}H_{14}O$. It appears to be an aldehyde and has a structure related to that of lactarazulene (69, 133, 202), a $C_{15}H_{18}$ azulene also found in the orange agaric. A third azulene which is of interest was isolated from the orange agaric. It is verdazulene, $C_{15}H_{16}$ (213), blue-green in color; according to the analysis, it probably has an exocyclic double bond.

Later Willstaedt (214) isolated from the orange agaric a violet azulene which contained a carboxyl group. It is not known whether the carboxyl group occurs naturally or has been formed from the lactaroviolin by a Cannizzaro reaction of the aldehyde group. A careful extraction of the orange-red fungus with alcohol without exposure to oxygen or enzymatic dehydrogenation gave an orange substance which was partially dehydrogenated on vacuum distillation to lactarazulene. Willstaedt has designated the compound "protazulene" (214).

Šorm (186) has isolated an orange bicyclic hydrocarbon from wormwood (*Artemisia absinthium* L.), by chromatography of a fraction of the oil; this hydrocarbon has four double bonds and the formula $C_{15}H_{20}$. It is unusually unstable in air and turns greenish blue on standing, apparently dehydrogenating spontaneously to chamazulene, with some polymerization. Šorm has given the name "chamazulenogen" to this dihydrochamazulene, and has postulated that his compound may be identical with Willstaedt's protazulene (see above).

Šorm (181) has also isolated a compound similar to, but not identical with, guaiazulene by the palladium dehydrogenation of δ -guaiene, which he calls "isoguaiazulene." Isoguaiazulene is closely related to *Se*-guaiazulene, since both azulenes appear to arise from the guaiazulene skeleton by migration of alkyl groups on dehydrogenation. Unpublished researches from Plattner's laboratory indicate that *Se*-guaiazulene and isoguaiazulene are not identical, judging by their spectra, color, and the melting points of their derivatives. It should be pointed out that the usual *Se*-guaiazulene product is not homogeneous. It consists of guaiazulene, 7-isopropyl-2,4-dimethylazulene (principal constituent),

and traces of two other azulenes, one of which may be identical with Šorm's isoguaiazulene. The mild sulfur dehydrogenation of a 7-isopropyl-2,4-dimethylhexahydroazulene has given a product identical in mixed melting point and spectrum in the visible, ultraviolet, and infrared regions with the main constituent of *Se*-guaiazulene; hence the structure of *Se*-guaiazulene is virtually certain. Since Šorm's isoguaiazulene is not identical with *Se*-guaiazulene, and since isoguaiazulene is derived from a compound having the guaiazulene skeleton, it is apparent that a rearrangement other than the 1 → 2 migration of alkyl groups (see page 137 and Section III, G) must be involved.

III. SYNTHESSES OF AZULENES

A. FROM CYCLODECADIONE

The first total azulene synthesis was carried out by Pfau and Plattner (109) from cyclopentenocycloheptanone, made from 1,6-cyclodecadione.

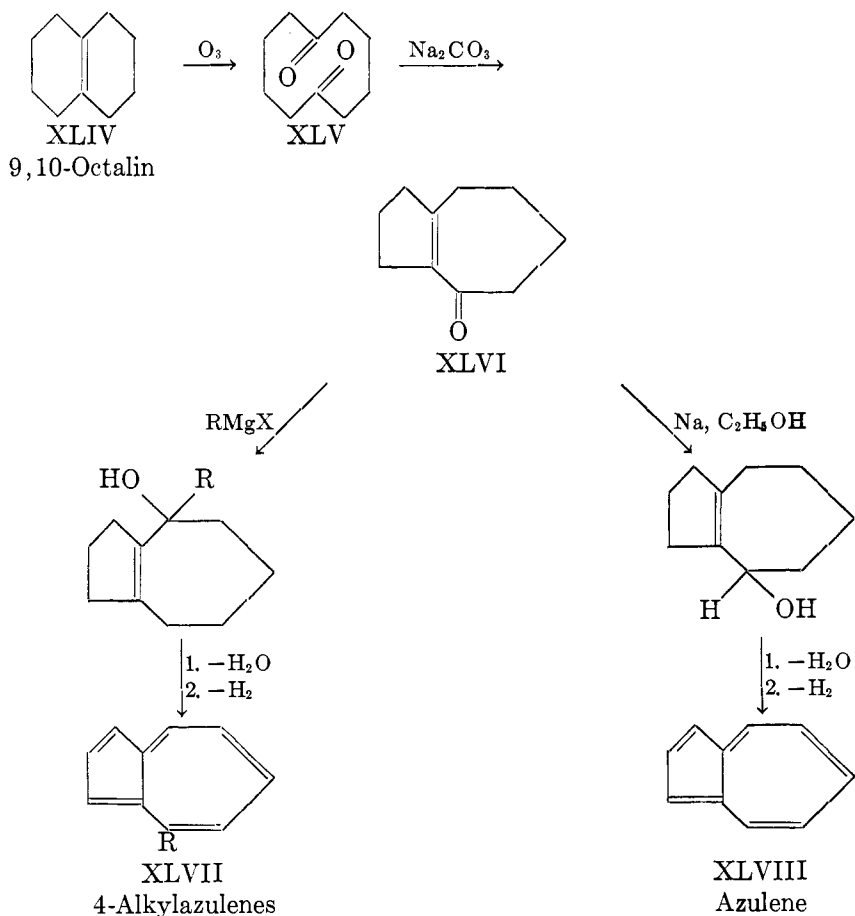

This method is of limited applicability for the preparation of substituted azulenes, but it served as a method for the preparation of some 4-alkylazulenes

and later as a method for the preparation of azulene itself, thus confirming the structure of the azulene nucleus (143).

In this procedure β -decalol is dehydrated to 9,10-octalin (XLIV), which is purified *via* the nitrosochloride and then ozonized according to Hückel (59) to give 1,6-cyclodecadione (XLV). The diketone is cyclized with sodium carbonate (60) to give cyclopentenocycloheptanone (XLVI). This product may be treated with Grignard reagents to give 4-alkylazulenes (XLVII), or reduced and dehydrated to give, after dehydrogenation, azulene itself (XLVIII). The azulenes prepared *via* the Hückel ketone include, in addition to the parent compound (143), 4-phenyl-, 4-methyl-, and 4-ethylazulenes (109).

B. RING-EXPANSION METHODS OF SYNTHESIS

1. Diazoacetic ester method

By far the most widely used, and the most controversial, of the synthetic methods used for the azulenes is the application of ring expansion of aromatic compounds with diazoacetic ester. This procedure was discovered by Buchner (19) and was first applied to the synthesis of azulenes by Plattner (149). In the simplest case, the action of diazoacetic acid on indan, the action of the reagent on the various Kekulé forms leads to identical end products, according to the following scheme:

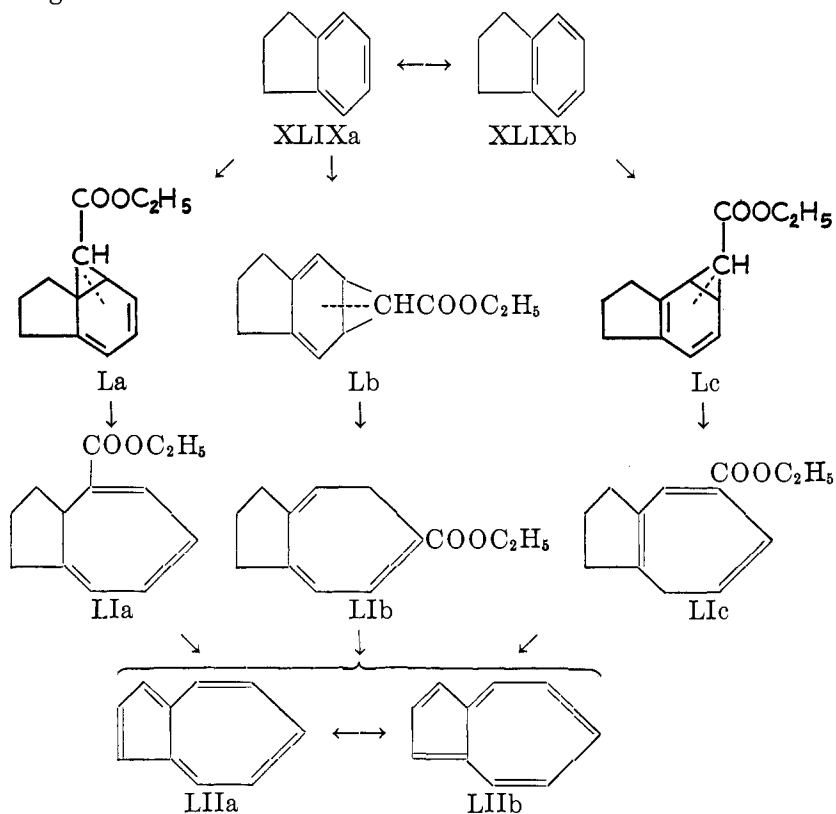

In this ring-expansion procedure the indan is treated dropwise with diazoacetic ester at 130–135°C. for about 2 hr. Upon completion of the addition the temperature is raised to 160–165°C. for several hours. Afterwards the unreacted indan and diazoacetic ester are distilled off and the cycle is repeated several times, first removing the high-boiling addition product. The addition product may be dehydrogenated directly to give a possible mixture of azulene-carboxylic esters, or the esters may be saponified to give the carboxylic acids which are decarboxylated and dehydrogenated to azulene (LII).

(a) Substituted azulenes

In the case of the synthesis of alkyl-substituted azulenes, as well as of azulene-carboxylic acids, the position of attack of the diazoacetic ester can be seen to be of considerable importance. Although the experiments of Lathrop (81) and others have largely disproved the Mills–Nixon effect (90), and the results attributed to this effect have been explained in other ways, the Mills–Nixon concept is useful, and will be used here, in designating the two resonance forms of hydrindene. According to Mills and Nixon it would be expected that indan would react in the Kekulé form (XLIXa). This is, however, not the case in many instances, since mixtures are often obtained which could only result from the reaction of the indan in both Kekulé forms. Hence these results may be considered as additional evidence against the Mills–Nixon hypothesis.

In spite of all the difficulties and ambiguities, the diazoacetic ester ring-expansion procedure is a useful one for azulenes, especially since chromatographic and partition procedures are available for the separation of the mixtures obtained (137, 138). It is also often possible, at the present time, to locate unequivocally the position of a substituent in a new azulene by comparison of its visible spectrum with those of known azulenes. These facts, together with the discovery that certain substituted indans give single diazoacetic ester addition products, make possible the use of this ring-expansion procedure for the synthesis of azulenes substituted in all except the 5-, 6-, and 7-positions. In some cases, as will be illustrated shortly, even 5- and 7-substituted azulenes can be obtained by the diazoacetic ester expansion of indans. The 6-alkylazulenes (mixed with the 5-isomer) are also sometimes available indirectly by this or a related procedure, as will be seen later.

An interesting case of the unpredictability of the reaction of substituted indans with diazoacetic ester is seen in the difference in products of the reaction of diazoacetic ester with 1-isopropyl-4,6-dimethylindan to give mainly 1-isopropyl-4,7-dimethylazulene (203), and with 1,5,7-trimethylindan to give principally 1,6,8-trimethylazulene (205). Here we have two indans, in which the benzene rings are identically substituted, which react in different Kekulé forms to give azulenes differently substituted in the seven-membered ring. It is apparent, then, that the form in which the indan will react with diazoacetic ester is dependent on the size and position of substituents present in both rings.

A good illustration of how the diazoacetic ester ring-expansion method can give an unequivocal product, with the Kekulé form that is not the predominant one according to Mills and Nixon, is to be found in the synthesis of 2-isopropyl-

5-methylazulene by Arnold and Spielman (9). The starting material, 2-isopropyl-5-methylindan, is prepared from *p*-xylylisopropylmalonic acid through the substituted acetic acid to 2-isopropyl-6-methylindan-1-one. The following possibilities are present in the ring expansion:

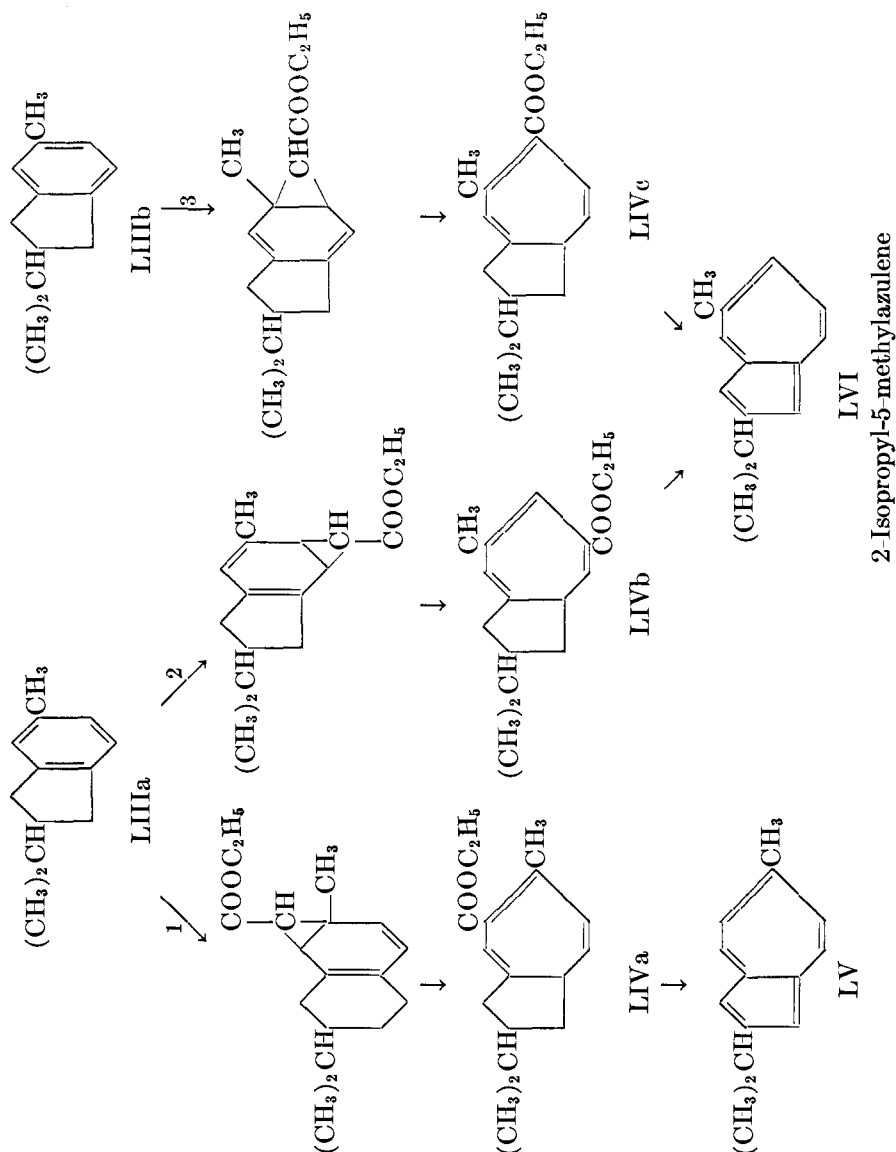

Starting with the Kekulé form LIIIa, it can be seen that two different azulenes might be obtained *via* routes 1 and 2. Since addition at the bridgehead is considered unlikely, it will be seen that the Kekulé form LIIIb could lead only to a 5-methylazulene. Since the product obtained is apparently pure and of spectral group I (see Section IV, D) and, further, since the spectrum, as compared with

that of 2-isopropylazulene, is shifted about 12μ toward the longer wave lengths, it is concluded that the product must be 2-isopropyl-5-methylazulene (LVI). Substitution in the 6-position has been found to cause a shift toward the shorter wave lengths. Hence path 1 is eliminated as a possibility, leaving paths 2 and 3. (See page 143.)

It might reasonably be expected, on steric grounds, that this reaction would proceed by route 2. This is the only path in which the attack is on a double bond which is not adjacent to a bridgehead or a substituent, both of which would reduce the accessibility of the double bonds. In other cases, however, neither the Mills-Nixon hypothesis nor reasoning on steric grounds is an infallible guide to the route by which diazoacetic ester ring expansion of substituted indans will proceed. This synthesis is shown to proceed by path 2, since conversion of the carboxyl to a methyl group by the methylating procedure of Arnold (6) results mainly in 2-isopropyl-5,7-dimethylazulene (LVII), according to the spectrum. Reduction of the ester is by the Bouveault-Blanc procedure and simultaneous dehydration and dehydrogenation is effected by palladium on charcoal.

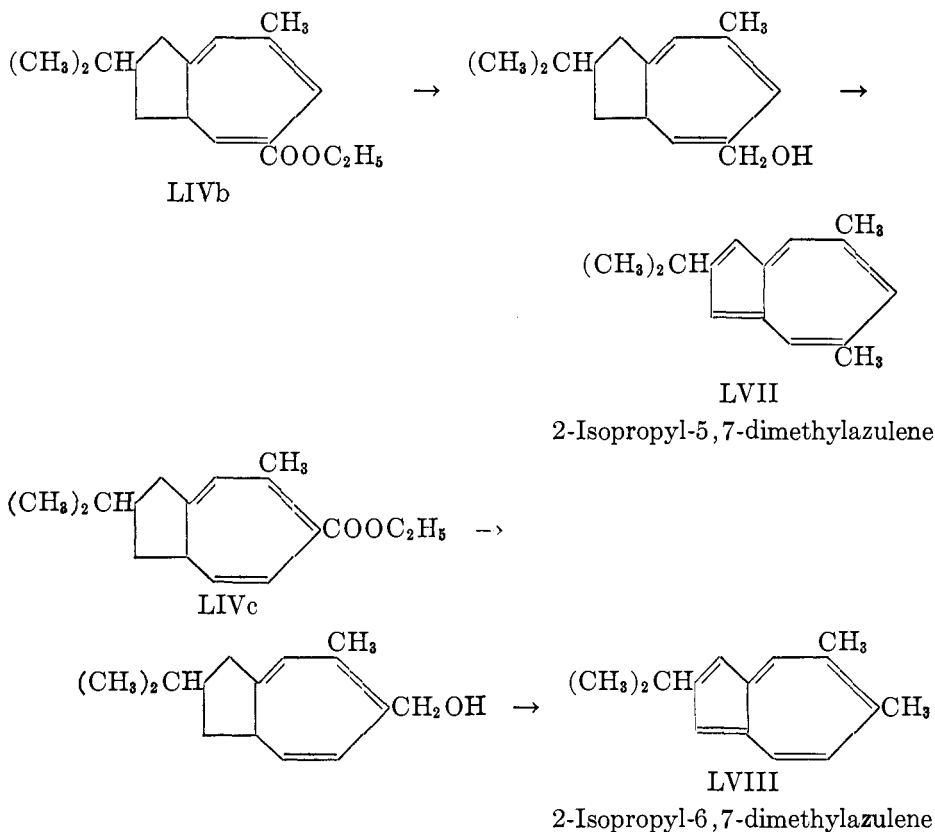

The diazoacetic ester ring-expansion method gives yields of azulene as high as 15 per cent, as in the case of 2-methylazulene. In other cases, as with

TABLE 1
Azulenes prepared by the diazoacetic ester method

AZULENE	STARTING MATERIAL AND METHOD	REFERENCES
Azulene	Indan	(204)
1-Methylazulene	1-Methylindan, obtained from α -indanone <i>via</i> the Grignard reaction.	(150)
1-Isopropylazulene	1-Isopropylindan	(7)
1-Phenylazulene	1-Phenylindan, obtained from α -indanone as above. The 1-phenylazulene obtained is contaminated with some 2-phenylazulene resulting from migration of the phenyl substituent during dehydrogenation. However, the two azulenes are easily separated by chromatography. This compound was also prepared by another route (see Section III,C).	(120)
2-Methylazulene	2-Methylindan, obtained by reduction of 2-methyl indanone.	(150)

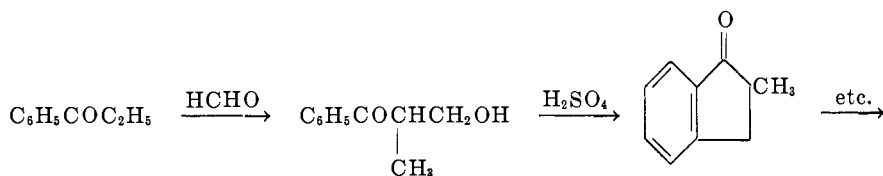

2-Ethylazulene 2-Ethylindan, obtained from β -indanone by the Grignard reaction. (117,204)

2-Isopropylazulene 2-Isopropylindan, obtained from isopropylbenzylmalonic acid (A) or from α -indanone and acetone (B): (132)

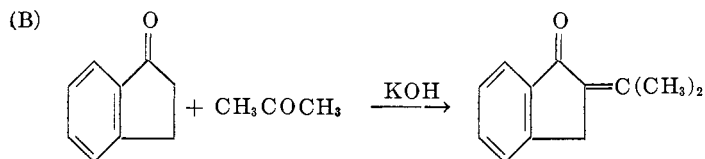
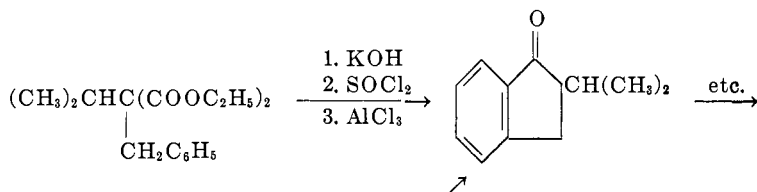
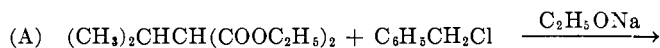

TABLE 1—Continued

AZULENE	STARTING MATERIAL AND METHOD	REFERENCES
2-Phenylazulene	2-Phenylindan, obtained from desoxybenzoin by a procedure similar to that used in the preparation of 2-methylazulene (see above).	(147)
5-Methylazulene	5-Methylindan, prepared by chloromethylation of indan. The product was later found, on spectroscopic comparison (136) with a pure sample of 5-methylazulene (180), to contain about 50 per cent of 4-methylazulene, probably arising from contamination of the indan used for chloromethylation.	(144)
1,2-Dimethylazulene	1,2-Dimethylindan, obtained from 2-methyl-1-indanone (see under 2-methylazulene).	(150)
1,3-Dimethylazulene	1,3-Dimethylindan, obtained as indicated below:	(123)
$\begin{array}{c} \text{C}_6\text{H}_5\text{CHCH}_2\text{COOH} \\ \\ \text{CH}_3 \end{array}$	$\xrightarrow[2. \text{AlCl}_3]{1. \text{SOCl}_2} \text{Indanone} \xrightarrow[2. \text{KHSO}_4]{1. \text{CH}_3\text{MgBr}} \text{2-Methylindanone} \xrightarrow{\text{etc.}}$	
1,4-Dimethylazulene	1,4-Dimethylindan, obtained as follows:	(149)
$\begin{array}{c} \text{C}_6\text{H}_5\text{CH}_2\text{Cl} \\ \\ \text{CH}_3 \end{array}$	$\xrightarrow[3. \text{HCl}]{1. \text{Mg}, 2. (\text{CH}_2\text{O})_x} o\text{-CH}_3\text{C}_6\text{H}_4\text{CH}_2\text{Cl} \xrightarrow{\text{CH}_2(\text{COOC}_2\text{H}_5)_2} o\text{-CH}_3\text{C}_6\text{H}_4\text{CH}_2\text{CH}(\text{COOC}_2\text{H}_5)_2 \xrightarrow{\text{KOH}} o\text{-CH}_3\text{C}_6\text{H}_4\text{CH}_2\text{CH}_2\text{COOH} \xrightarrow[2. \text{AlCl}_3]{1. \text{SOCl}_2} \text{4-Methylindanone} \xrightarrow[2. \text{KHSO}_4]{1. \text{CH}_3\text{MgX}} \text{4,7-Dimethylindanone} \xrightarrow{\text{etc.}}$	
4,8-Dimethylazulene	4,7-Dimethylindan, prepared as follows:	(150)
$\begin{array}{c} \text{CH}_3 \\ \\ \text{C}_6\text{H}_4 \\ \\ \text{CH}_2\text{Cl} \\ \\ \text{CH}_3 \end{array}$	$\xrightarrow{\text{CH}_2(\text{COOC}_2\text{H}_5)_2} \text{4,7-Dimethylindanone} \xrightarrow[3. \text{AlCl}_3]{1. \text{NaOH}, 2. \text{SOCl}_2} \text{4,7-Dimethylindanone} \xrightarrow{\text{etc.}}$	

TABLE 1—Continued

AZULENE	STARTING MATERIAL AND METHOD	REFERENCES
2-Ethyl-4-methylazulene.....	Obtained as a by-product in the production of 2-ethyl-8-methoxy-4-methylazulene, through splitting off the methoxyl group.	(204)
1,8-Dimethylazulene...	1,7-Dimethylindan	(127)
2-Isopropyl-5-methylazulene.....	2-Isopropyl-5-methylindan (<i>cf.</i> page 143) obtained by the chloromethylation of the indan.	(9)
1-Isopropyl-5(7)-methylazulene.....	1-Isopropyl-5(6)-methylindan; the spectrum indicates that the product is impure.	(7)
1-Isopropyl-6-methylazulene.....	1-Isopropylindan by methylation by the diazoacetic ester procedure (6); <i>cf.</i> page 144.	(7)
1,2,3-Trimethylazulene.....	1,2,3-Trimethylindan, obtained as follows:	(123)
$ \begin{array}{c} \text{C}_6\text{H}_5\text{COCH}_3 + \text{CH}_3\text{CHBrCOOC}_2\text{H}_5 \xrightarrow{\text{Zn}} \text{C}_6\text{H}_5\text{C} \begin{array}{c} \text{OH} \\ \\ \text{CCH}(\text{CH}_3)\text{COOC}_2\text{H}_5 \\ \\ \text{CH}_3 \end{array} \xrightarrow[\text{heat}]{\text{I}_2} \\ \\ \text{C}_6\text{H}_5\text{C} \begin{array}{c} \text{CH}_3 \\ \\ \text{C}=\text{CCOOC}_2\text{H}_5 \\ \quad \\ \text{CH}_3 \quad \text{CH}_3 \end{array} \xrightarrow[2. [\text{H}]]{1. \text{KOH}} \text{C}_6\text{H}_5\text{CH} \begin{array}{c} \text{CHCOOH} \\ \quad \\ \text{CH}_3 \quad \text{CH}_3 \end{array} \xrightarrow[2. \text{AlCl}_3]{1. \text{SOCl}_2} \\ \\ \begin{array}{c} \text{O} \\ \\ \text{C}_6\text{H}_4 \text{---} \text{C} \begin{array}{c} \text{CH}_3 \\ \\ \text{CH}_3 \end{array} \end{array} \xrightarrow[2. \text{KHSO}_4]{1. \text{CH}_3\text{MgX}} \begin{array}{c} \text{CH}_3 \\ \\ \text{C}_6\text{H}_4 \text{---} \text{C} \begin{array}{c} \text{CH}_3 \\ \\ \text{CH}_3 \end{array} \end{array} \xrightarrow{\text{etc.}} \end{array} $		
1,3,5-Trimethylazulene.....	1,3,5-Trimethylindan, obtained as follows (see second footnote to table 3 on page 189):	(206)
$ \begin{array}{c} \text{C}_6\text{H}_5\text{CH}_3 \xrightarrow[(\text{CH}_3\text{CO})_2\text{O}]{\text{AlCl}_3} p\text{-CH}_3\text{C}_6\text{H}_4\text{COCH}_3 \xrightarrow[\text{Zn}]{\text{CH}_2\text{BrCOOC}_2\text{H}_5} \\ \\ p\text{-CH}_3\text{C}_6\text{H}_4\text{C} \begin{array}{c} \text{CHCOOC}_2\text{H}_5 \\ \\ \text{CH}_3 \end{array} \xrightarrow[2. \text{KOH}]{1. [\text{H}]} p\text{-CH}_3\text{C}_6\text{H}_4\text{CH} \begin{array}{c} \text{CHCH}_2\text{COOH} \\ \\ \text{CH}_3 \end{array} \xrightarrow[2. \text{AlCl}_3]{1. \text{SOCl}_2} \\ \\ \begin{array}{c} \text{CH}_2 \\ \\ \text{C}_6\text{H}_3 \text{---} \text{C} \begin{array}{c} \text{CH}_3 \\ \\ \text{CH}_3 \end{array} \end{array} \xrightarrow[2. \text{KHSO}_4]{1. \text{CH}_3\text{MgI}} \begin{array}{c} \text{CH}_3 \\ \\ \text{C}_6\text{H}_3 \text{---} \text{C} \begin{array}{c} \text{CH}_3 \\ \\ \text{CH}_3 \end{array} \end{array} \xrightarrow{\text{etc.}} \end{array} $		

TABLE 1—Continued

AZULENE	STARTING MATERIAL AND METHOD	REFERENCES
1,6,8-Trimethylazulene.....	1,5,7-Trimethylindan, obtained as follows:	(205)
	<p>The expected product here would be 1,5,8-trimethylazulene; however, the product has a distinct violet color and therefore must contain a substituent in the 6-position.</p>	
1-Isopropyl-3,7-dimethylazulene.....	By the reaction of 3,7-dimethylindan-1-one, prepared as indicated above, with isopropylmagnesium bromide, followed by ring expansion of the dehydrated and dehydrogenated product.	(206)
2-Isopropyl-5,7-dimethylazulene.....	2-Isopropyl-5-methylindan (<i>cf.</i> page 143) by reduction of the carboxylic acid intermediate formed by ring expansion.	(9)
6-Isopropyl-1,4-dimethylazulene.....	Obtained as a by-product in the synthesis of guiazulene from 6-isopropyl-1,4-dimethylindan (see below).	(127,128)
2-Ethyl-4,8-dimethylazulene.....	2-Ethyl-4,7-dimethylindan, obtained in a synthesis similar to that of 4,8-dimethylindan (page 146), substituting ethyl 2-ethylmalonate for ethyl malonate.	(204)

TABLE 1—Continued

AZULENE	STARTING MATERIAL AND METHOD	REFERENCES
1-Isopropyl-4,7-dimethylazulene.....	1-Isopropyl-4,6-dimethylindan, synthesized by a method similar to that used for 4,8-dimethylindan (page 146), except that the starting material is <i>m</i> -xylene instead of <i>p</i> -xylene. The intermediate indanone is treated with an isopropyl Grignard reagent. This azulene is known to be a 4,7-dimethylazulene (not 4,6-dimethylazulene, as was considered possible), because it is pure blue. Its spectrum is not shifted toward the shorter wave lengths, as would be expected in the case of a 6-substituted azulene.	(203)
6-Isopropyl-4,8-dimethylazulene.....	4,7-Dimethylindan (page 146) <i>via</i> 4,8-dimethylazulene-6-carboxylic ester, using an alkylating procedure related to that employed later by Arnold (7) (page 144):	(146)
<p style="text-align: center;"> <chem>Cc1ccc2c(c1)C(C)CC2 + N=[N+]C(=O)OCC >> Cc1ccc2c(c1)C(C)CC2C(=O)OCC</chem> <chem>Cc1ccc2c(c1)C(C)CC2C(=O)OCC + 2CH3MgI >> Cc1ccc2c(c1)C(C)CC2C(O)C(C)C</chem> <chem>Cc1ccc2c(c1)C(C)CC2C(O)C(C)C + HCOOH >> Cc1ccc2c(c1)C(C)CC2C=C(C)C</chem> <chem>Cc1ccc2c(c1)C(C)CC2C=C(C)C + [H] >> Cc1ccc2c(c1)C(C)CC2C(C)C</chem> </p>		
6-(2'-Hydroxyisopropyl)-4,8-dimethylazulene.....	See the preceding synthesis.	(146)
6-Isopropenyl-4,8-dimethylazulene.....	See above.	(146)
2-Ethyl-8-methoxy-4-methylazulene.....	Prepared similarly to 2-ethyl-4,8-dimethylazulene (page 148), except that one methyl group is replaced by a methoxyl group. The yield is very poor.	(204)

TABLE 1—Continued

AZULENE	STARTING MATERIAL AND METHOD	REFERENCES
1,3,4,8-Tetramethylazulene.....	1,3,4,7-Tetramethylindan, obtained as follows:	(129)
	$ \text{CH}_3\text{CH}=\text{CHCOCl} \xrightarrow[\text{CS}_2]{\text{AlCl}_3} \text{1,3,4,7-tetramethylindan-5-carbaldehyde} $	$ \xrightarrow[2. \text{KHSO}_4]{1. \text{CH}_3\text{MgBr}} $
		 $ \xrightarrow{\text{etc.}} $
2-Isopropyl-4,8-dimethylazulene (vetivazulene).....	2-Isopropyl-4,7-dimethylindan, which is prepared from chloromethyl- <i>p</i> -xylene and ethyl 2-isopropylmalonate as in the synthesis of 4,7-dimethylindan (page 146).	(110)
7-Isopropyl-1,4-dimethylazulene (guai-azulene).....	6-Isopropyl-1,4-dimethylindan. The yield is very small. Hippchen (56) attempted to synthesize guai-azulene, but was unable to isolate the desired product from the mixture obtained. In the synthesis of Plattner <i>et al.</i> (127, 128) special measures were taken to prevent contamination of the intermediates with 7-isopropyl products. The starting <i>m</i> -cymene contained about 20 per cent of the <i>para</i> isomer.	(56, 127, 128)
 LIX	$ \text{1,4-dimethyl-2-(chloromethyl)benzene} \xrightarrow[\text{HCl}]{\text{HCHO}} \text{1,4-dimethyl-2-(chloromethyl)benzene} \xrightarrow[2. \text{KOH}]{1. \text{CH}_2(\text{COOC}_2\text{H}_5)_2} \text{6-isopropyl-1,4-dimethylindan-5-carbaldehyde} $ $ \text{6-isopropyl-1,4-dimethylindan-5-carbaldehyde} \xrightarrow[2. \text{AlCl}_3]{1. \text{SOCl}_2} \text{6-isopropyl-1,4-dimethylindan-5-one} \xrightarrow[2. \text{KHSO}_4]{1. \text{CH}_3\text{MgX}} \text{7-isopropyl-1,4-dimethylazulene} $	

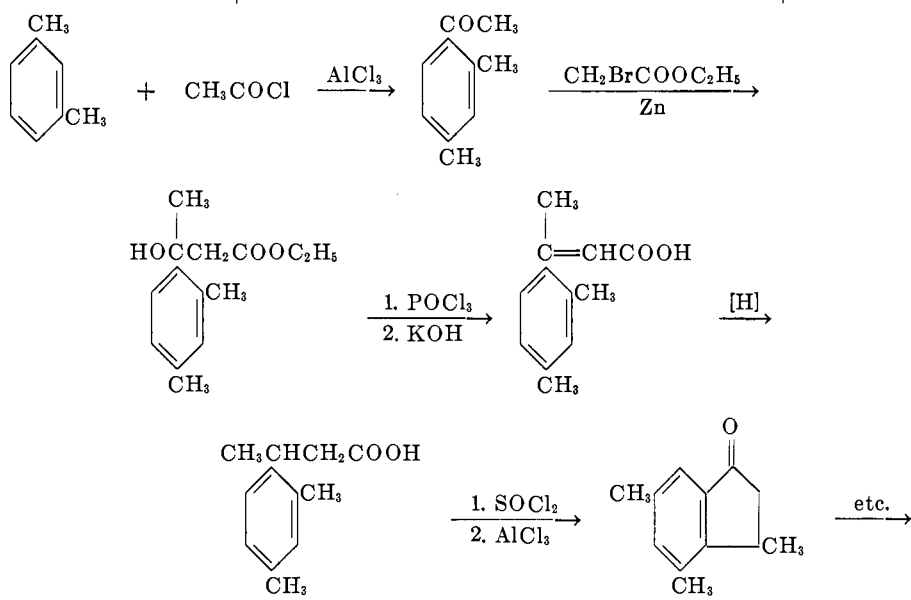
TABLE 1—*Concluded*

AZULENE	STARTING MATERIAL AND METHOD	REFERENCES
7-Isopropyl-1,4-dimethylazulene (guaiazulene)— <i>continued</i> . .	 <p style="text-align: center;">LX</p>	
<p>Separation of the intermediates from the contaminant arising from <i>p</i>-cymene was accomplished by crystallization of the amide of 4-isopropyl-2-methyldihydrocinnamic acid (LIX). A small amount of pure isomeric 5-isopropyl-2-methyldihydrocinnamic acid was obtained by chromatography of the amide from the mother liquor.</p> <p>The indan (LX) was treated in the usual way with diazoacetic ester. Dehydrogenation by various methods gave, in all cases, mixtures of azulenes which could not be separated by crystallization of the trinitrobenzene or picric acid derivatives. Only repeated chromatography or Craig partition (31) resulted in separation of guaiazulene from its contaminant, which was probably 6-isopropyl-1,4-dimethylazulene.</p>		

1-methylazulene and azulene itself, the yield is less than 1 per cent by this procedure. The azulenes listed in table 1 have been prepared by the diazoacetic ester method. Where of interest the synthesis of the starting indan has been indicated.

(b) Benzazulenes and hydrobenzazulenes

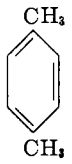
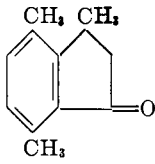
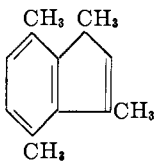
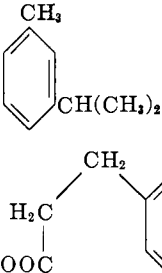
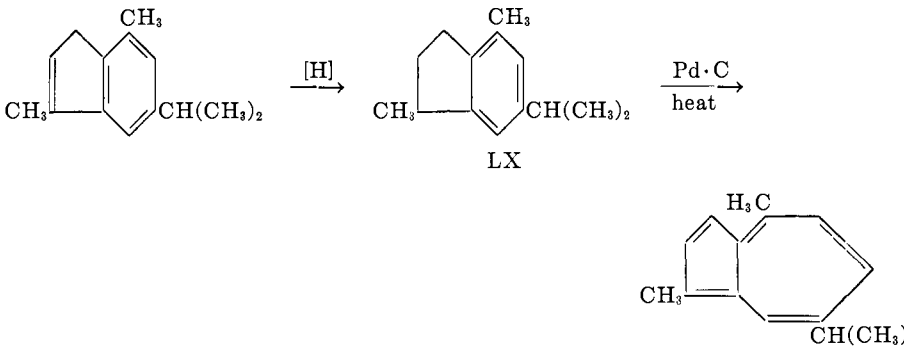
The diazoacetic ester method of ring enlargement has been applied recently to the synthesis of benzazulenes, which retain the conjugated unsaturation present in the parent compound.

1,2-Benzazulene: This compound was independently synthesized in three laboratories, those of Plattner (119), Treibs (193, 194, 195), and Nunn and Rapson (58, 101), by the reaction of fluorene with diazoacetic ester.

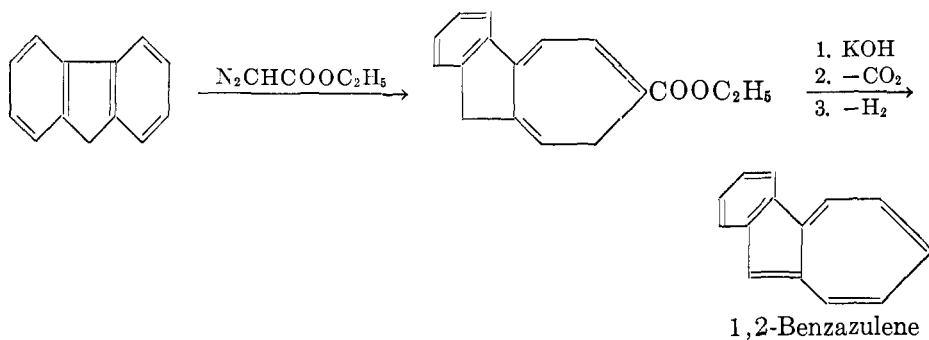

Nunn and Rapson (101) have also prepared 1,2-benzazulene by the diazo-methane ring expansion of 3-ketohexahydrofluorene (48) (see Section III, B, 3)

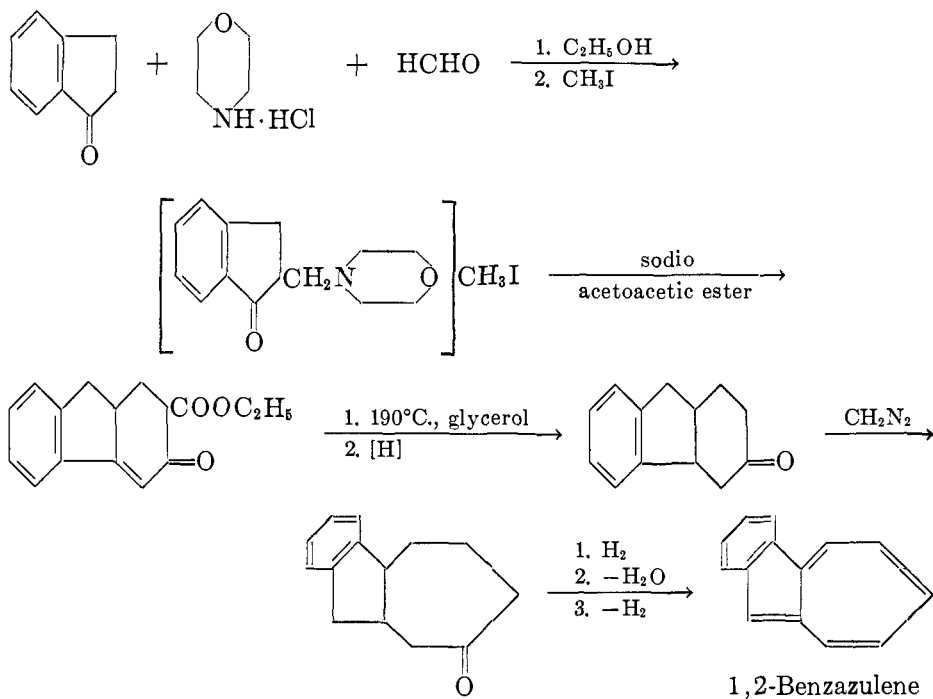

The synthesis of 1,2-indenoazulene has been reported by the diazoacetic ester ring expansion of diphenosuccidan (135, 158).

4,5-Benzazulene (LXI): A synthesis of this compound has been reported by Nunn and Rapson (102), utilizing the cyclopenteneacetic acid method of Robinson (157).

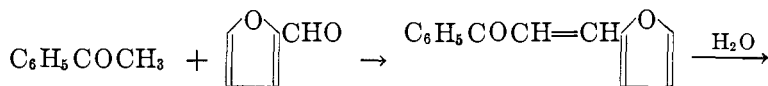

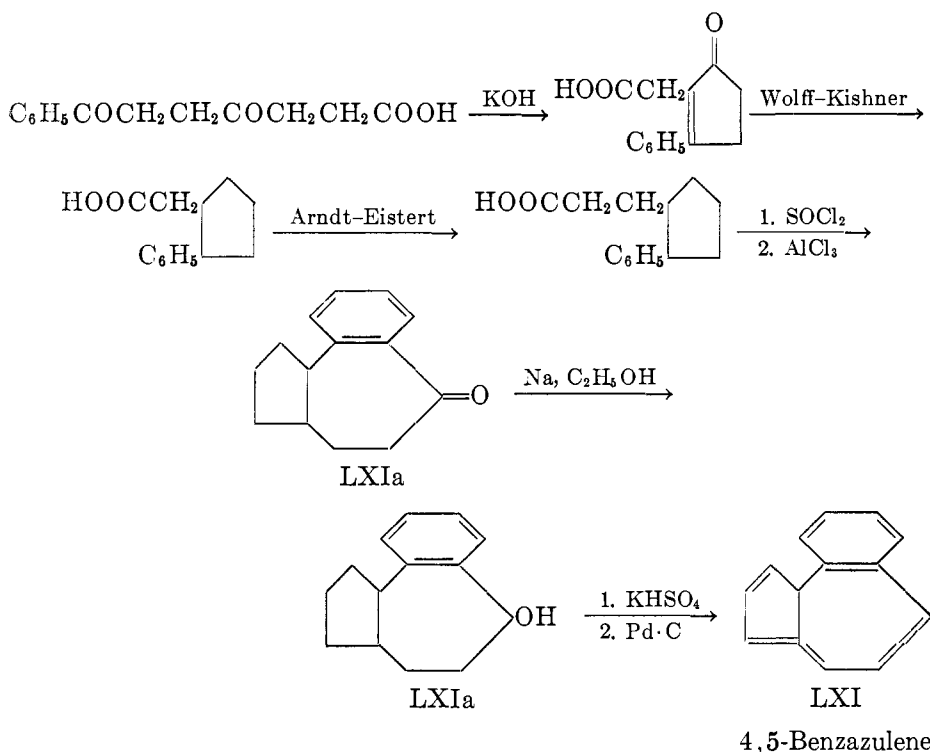

Cook (29) also attempted to synthesize 4,5-benzazulene, but only prepared the hexahydro-1-keto-4,5-benzazulene.

In view of the fact that 4,5-benzazulene could not be isolated, except as its trinitrobenzene complex, an attempt was made by Nunn (99a) to prepare 6-methyl-4,5-benzazulene. This synthesis was carried out by treating LXIa with a methyl Grignard reagent and then dehydrating. When dehydrogenation of the intermediate methylhexahydro-4,5-benzazulene was attempted, only the isomeric 9-methylphenanthrene could be isolated from the reaction mixture (see Section III, H).

5,6-Benzazulene: Cook (28) attempted to synthesize 5,6-benzazulene, but

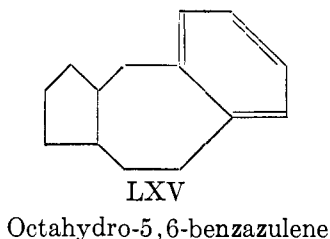

could only prepare an octahydro derivative (LXV). Plattner (124) succeeded

in preparing 5,6-benzazulene according to the following scheme:

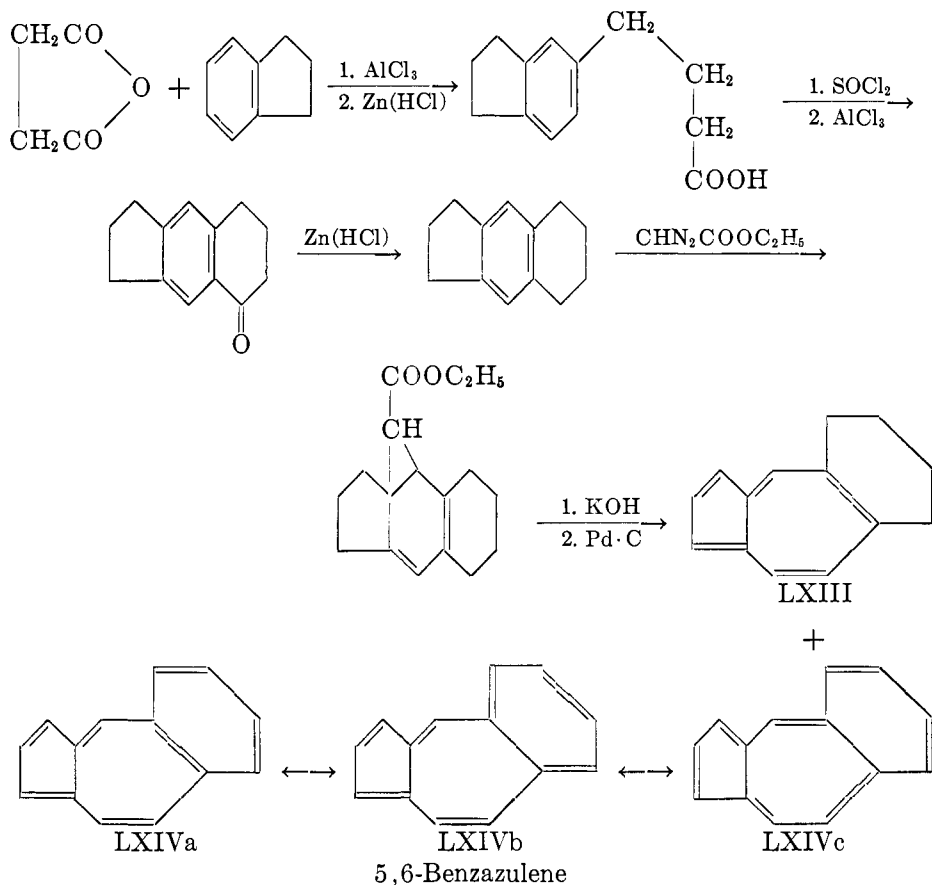

5,6-Tetramethyleneazulene (LXIII) (124): This compound was obtained as a by-product in the synthesis of 5,6-benzazulene.

1,8-Trimethyleneazulene (LXVII) (125, 198): This substance was prepared by the diazoacetic ester ring expansion of tetrahydroacenaphthene (LXVI).

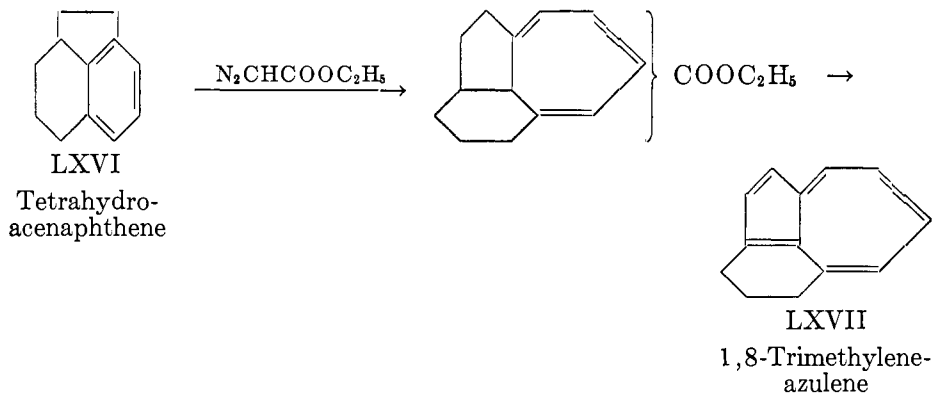

(c) Azulenecarboxylic acids

The intermediate carboxylic esters, obtained in the course of the diazoacetic ester ring expansion, have been dehydrogenated without saponification in a number of cases to give azulenecarboxylic esters, convertible to free acids (66, 130, 145, 193, 195), other esters (145), amides (130), hydroxymethyl groups (126, 130, 142), acetyl (146), isopropenyl (142, 146), hydroxyisopropyl (146), and isopropyl groups (142, 146). Conversion of carbethoxyl groups to methyl groups, *via* the hydroxymethyl derivatives, is also possible if reduction of the ester is carried out prior to dehydrogenation. Dehydration and dehydrogenation then proceed in one step (6, 7, 9). In certain cases the above conversion of carbethoxyl groups to methyl or isopropyl groups makes possible the synthesis of 5- and 6-alkylazulenes by the diazoacetic ester procedure, after separation of the mixture of acids. Exceptionally, 1,2,3-trimethylazulene-6-carboxylic acid was obtained as a by-product in the synthesis of 1,2,3-trimethylazulene by the usual diazoacetic ester procedure (123). The compounds mentioned in this paragraph may be seen in the table of azulenes (Section III, J, items 40-42, 52-66, and 85-87).

It is of interest that recent work on the synthesis of azulenecarboxylic acids by the diazoacetic ester route has demonstrated that mixtures of 5- and 6-azulene-carboxylic esters are obtained (128a) which may be separated by chromatography on alumina. It has been found that one of these azulenecarboxylic esters is appreciably easier to saponify than the other. This saponification takes place to some extent on the alumina column, in consequence of which the hydrolyzed acid is much more strongly held on the column. As a result there is a considerable enrichment of the 5-carboxylic acid content of the effluent, with the 6-isomer being preferentially retained on the column. No trace of any 4-carboxylic acid fraction in the reaction mixtures has been obtained.

The course of a typical set of azulenecarboxylic ester transformations is given below (146):

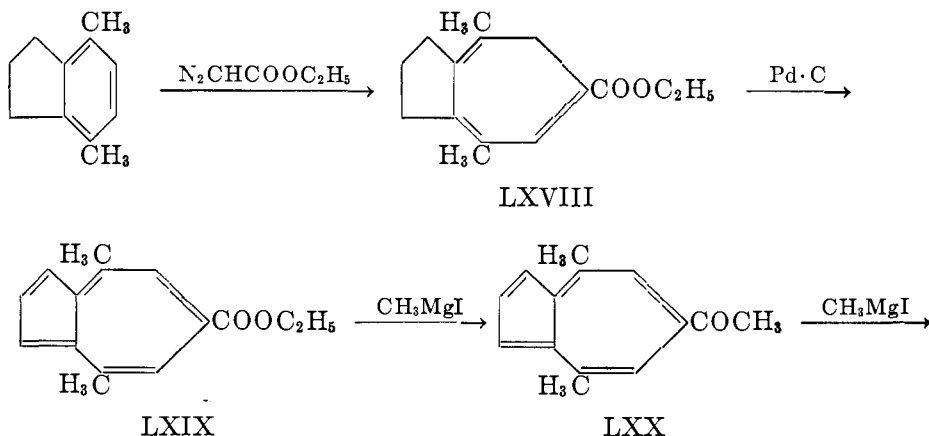

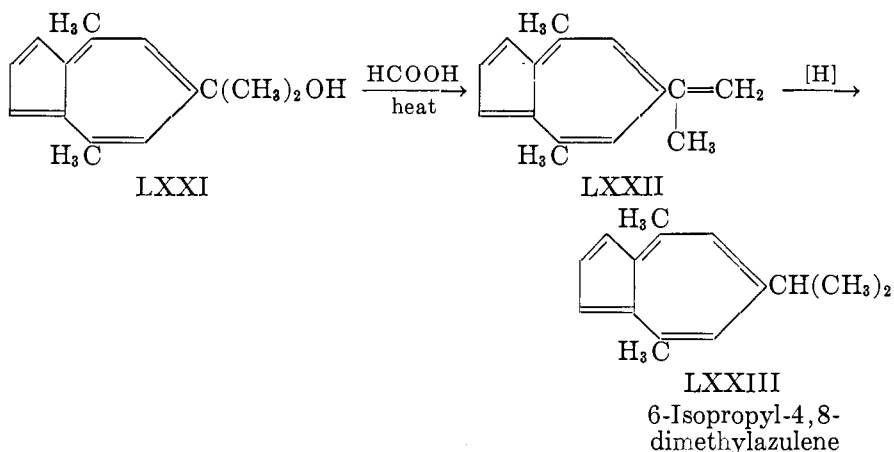

2. Demjanow ring expansion

Related to the diazoacetic ester procedure is the Demjanow ring-expansion method (32, 33, 34, 35), first applied to azulene synthesis by Arnold (4). In an effort to prepare 6-methylazulene, inaccessible by the diazoacetic ester route, Arnold carried out a Demjanow ring expansion with 5-aminomethylindan, as indicated below. However, the product was later found by Plattner to contain about 75 per cent of 5-methylazulene and only 25 per cent of 6-methylazulene (136).

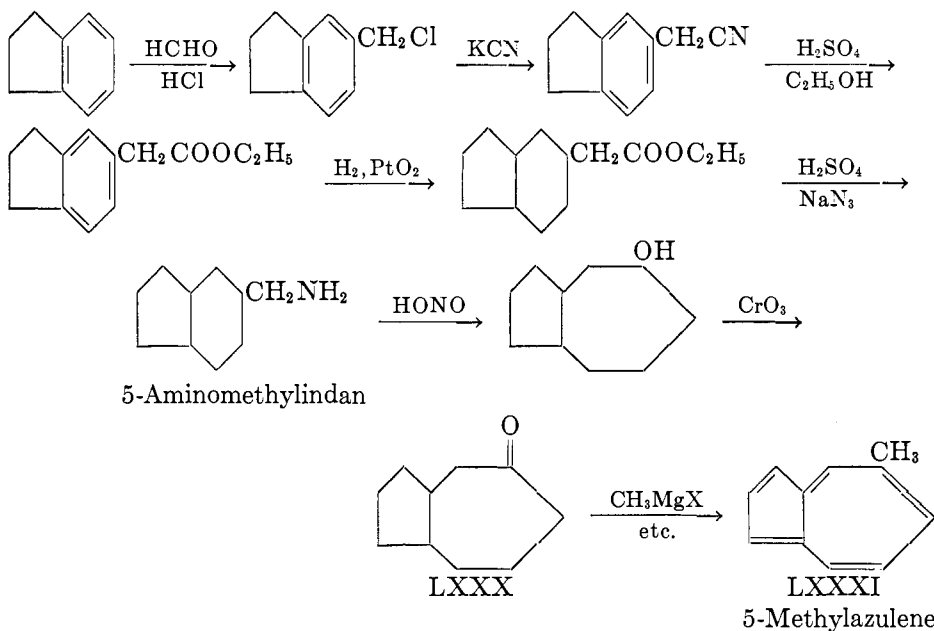

Plattner (131) carried out this synthesis in a somewhat different fashion, obtaining also a mixture containing 12-25 per cent of 6-methylazulene.

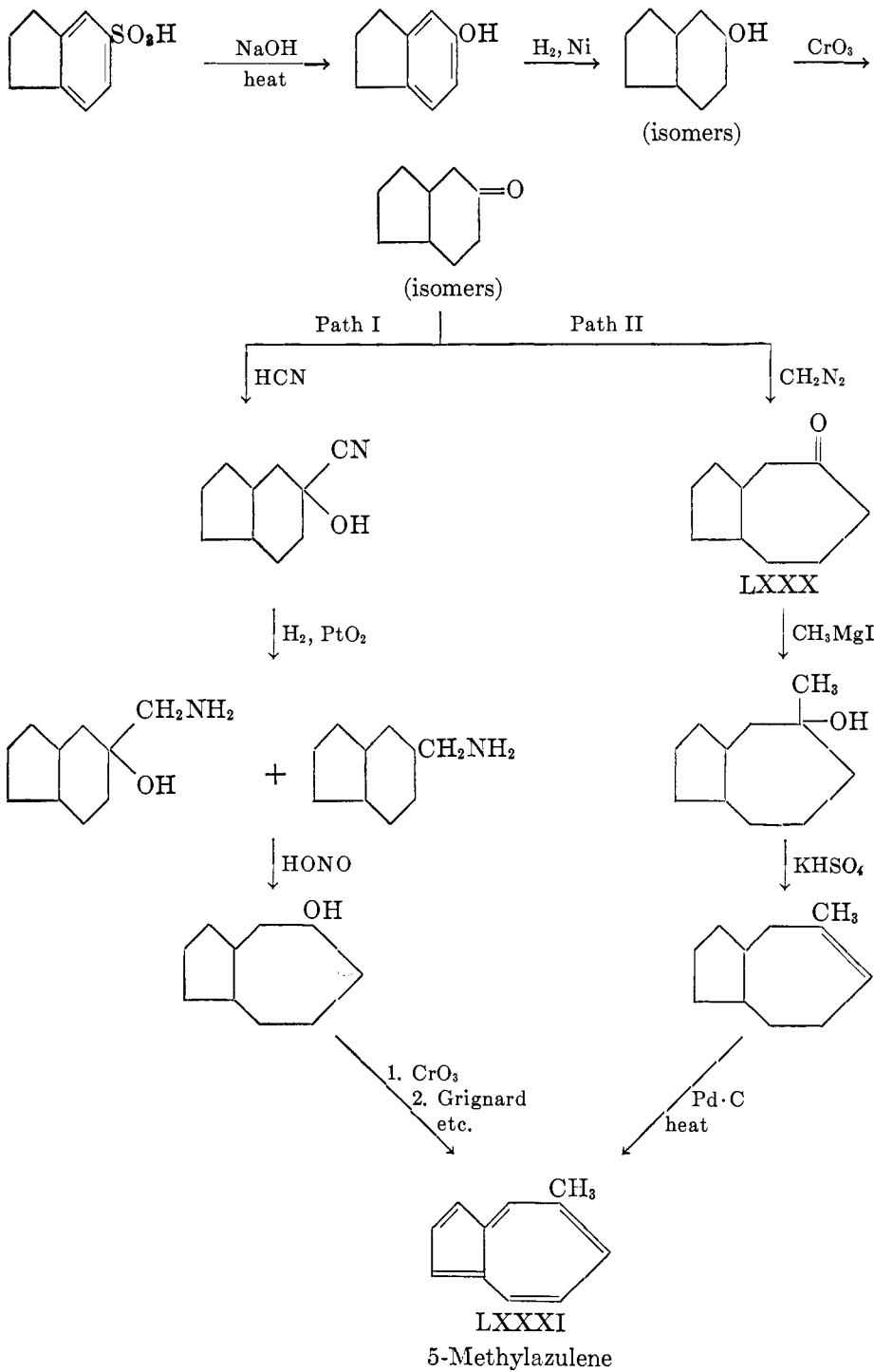

3. Diazomethane ring expansion

Path II above shows the application of the diazomethane ring-expansion method, first used by Meerwein (88), to azulene synthesis. It is of interest, in connection with the above syntheses, that Arnold (4) obtained two ketones (LXXX), both of which led to the same azulene. He assumed, therefore, that the two semicarbazones obtained were *cis-trans* isomers. Plattner (131) confirmed this view by separating the semicarbazones and isolating the pure *cis*- and *trans*-bicyclo[5.3.0]decan-3-ones.

The first use of the diazomethane ring-expansion method in azulene synthesis was by Coats and Cook (27), according to the scheme given below. However, the yields in this synthesis were very poor.

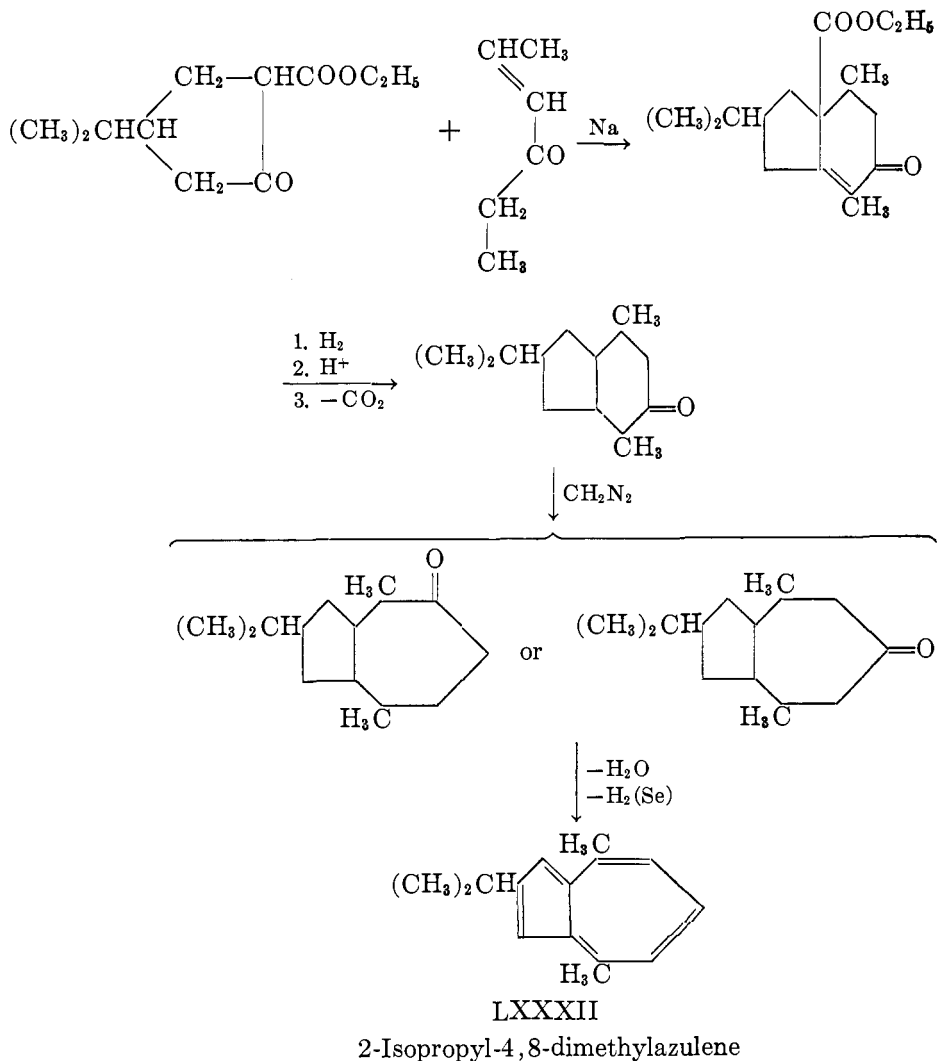

Another example of the diazomethane ring-expansion method was described in connection with the synthesis of 1,2-benzazulene (page 152) (101).

C. AZULENE SYNTHESSES FROM CYCLOHEPTANONE

Azulesenes have been prepared from cycloheptanone by building up the cyclopentane ring and then dehydrogenating the product. This procedure is well suited to the preparation of 1- and 2-substituted azulesenes. For 2-alkylazulesenes the synthesis of Plattner, Fürst, and Jirasek (121, 122) is applicable according to the scheme given below. Synthesis of polysubstituted azulesenes by this route might be possible using other α -halo acids.

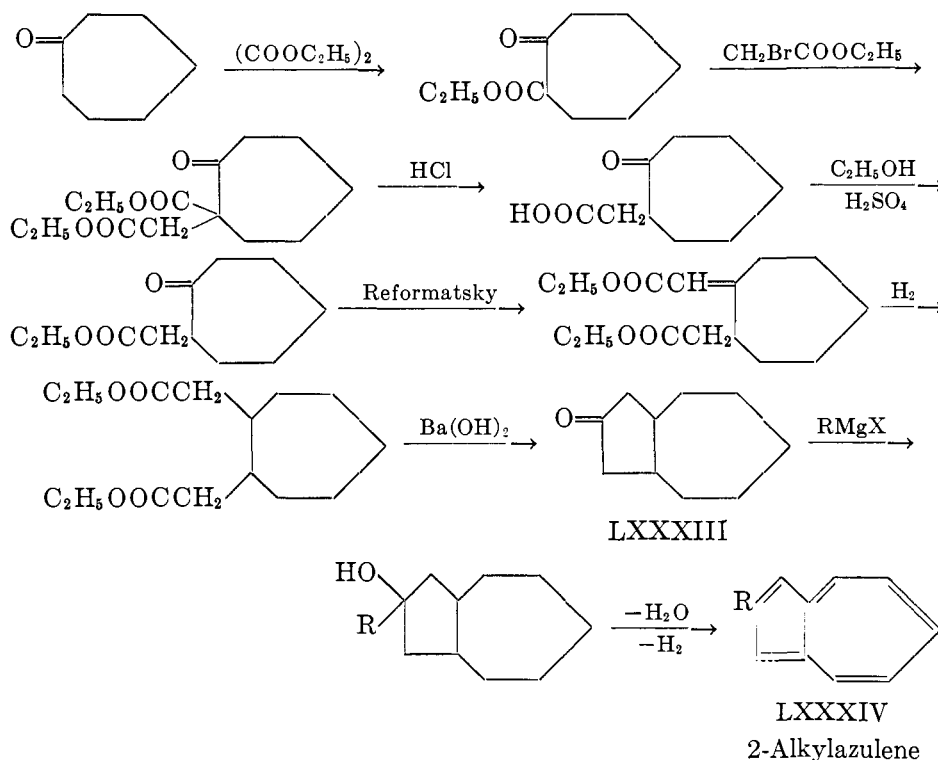

2-Ethylazulene (LXXXIV: R = C₂H₅) and 2-isopropylazulene (LXXXIV: R = isopropyl) (122), as well as the parent substance, bicyclo[5.3.0]decane (121), have been prepared by this method.

For the preparation of 1-alkylazulesenes the application of a modified (67) Stobbe condensation (189) to cycloheptanone by Plattner and Büchi (116) has proved to be extremely useful. This route was utilized somewhat later by Cook (29) in an unsuccessful attempt to prepare 1-phenylazulene. A successful synthesis of 1-phenylazulene by both this method, *via* LXXXVIII and phenylmagnesium bromide, and the diazoacetic ester route was recently completed by Plattner (120).

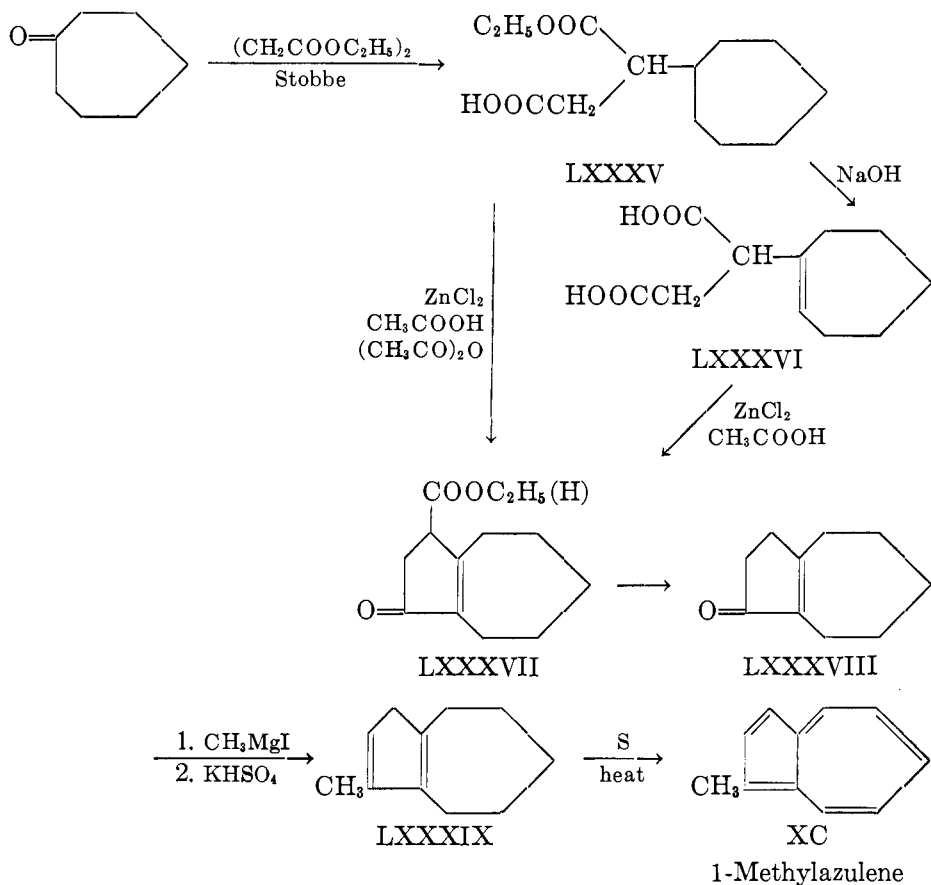

It will be seen that either the initial half-ester (LXXXV) or the hydrolyzed product (LXXXVI) can be condensed to the keto acid (LXXXVII). The cycloheptenocyclopentanone (LXXXVIII) may easily be converted to the parent compound, azulene (LII), or to other 1-alkylazulenes.

Braude and Forbes (19a) have synthesized azulene and its 1-methyl derivative from cycloheptanone in good yield, using a lithium alkenyl intermediate according to the following scheme:

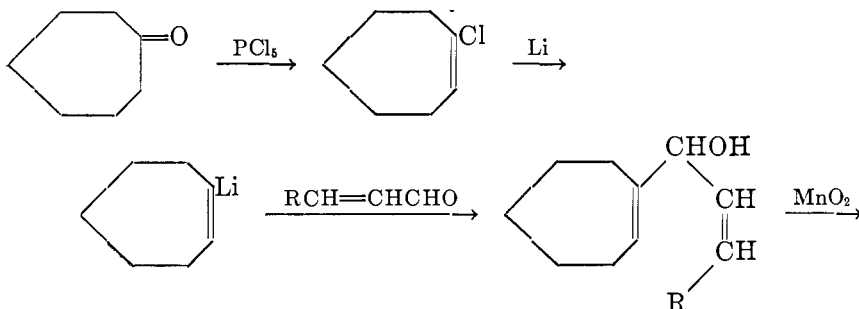

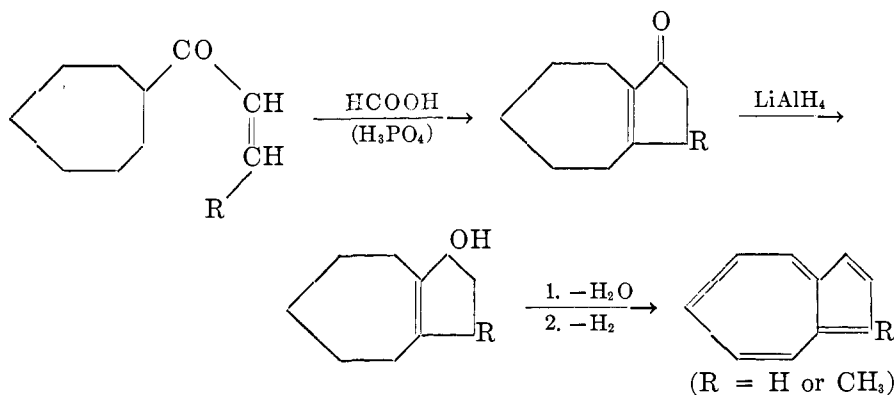

D. AZULENE SYNTHESSES FROM CYCLOPENTANONE

This procedure has been found to be well suited to the synthesis of 5- and 6-substituted azulenes, and it is potentially adaptable to the preparation of 4-alkylazulenes as well. The 6-alkylazulenes are usually inaccessible by any other route.

Šorm and Fajkoš (182) and Plattner and Studer (148) independently synthesized 6-methylazulene from cyclopentanonecarboxylic ester (XCV) (prepared by Dieckmann cyclization of ethyl adipate) by substantially identical methods. The synthesis of cyclopentane-1,2-diacetic acid (XCIX) (*cis* and *trans* isomers) is according to the method of Linstead and Meade (83).

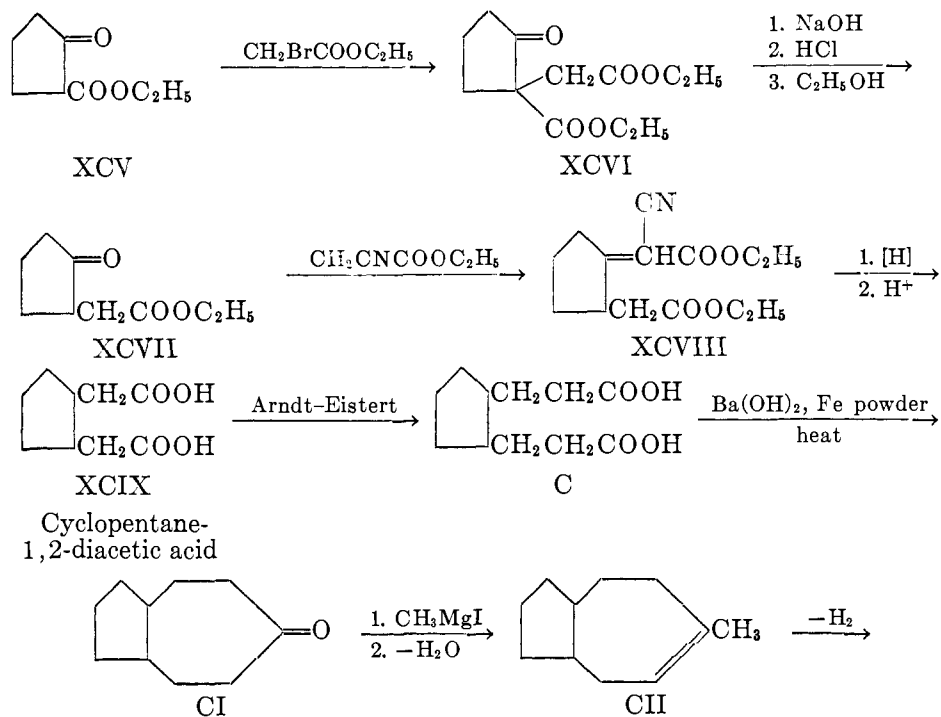

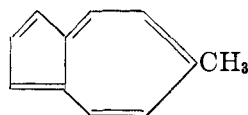

CIII

6-Methylazulene

4,6-Dimethylazulene has been prepared in a related procedure (184) by the reaction of ethyl cyclopentanecarboxylate (XCV) with ethyl α -bromopropionate. The rest of the synthesis is identical with that of 6-methylazulene.

2,6-Dimethylazulene was also prepared by Šorm (185) in a manner analogous to that used for 6-methylazulene (CIII), except that the appropriate methylcyclopentanecarboxylic ester, prepared by cyclization of ethyl β -methyladipate to ethyl 3-methylcyclopentan-5-one-1-carboxylate, is substituted for ethyl cyclopentanone-2-carboxylate (XCV).

5-Methylazulene (CXI) has also been synthesized from cyclopentanecarboxylic ester (XCV) by another related procedure (180), *via* a bicyclo[5.3.0]decan-3-one (CIX) in place of the bicyclo[5.3.0]decan-4-one (CI) used for the synthesis of 6-alkylazulenes. This represents the first synthesis of pure 5-methylazulene.

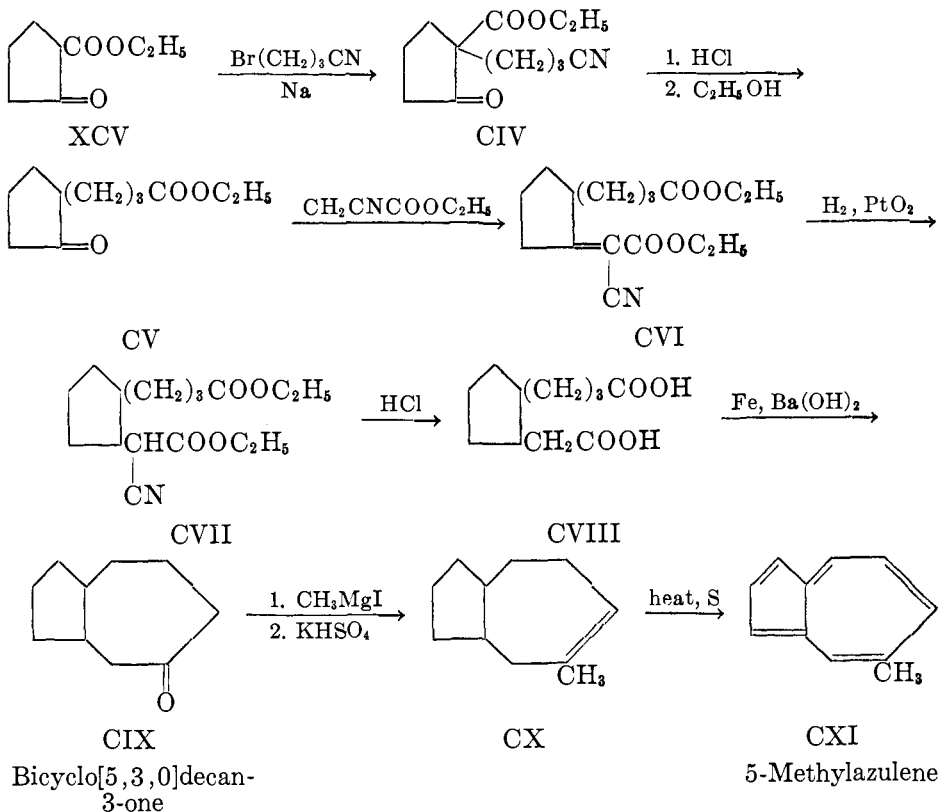

E. AZULENE SYNTHESSES FROM NATURAL PRODUCTS

Plattner and Magyar (141) have synthesized 1,4,7-trimethylazulene (CXV) starting with 2,8-dimethylbicyclo[5.3.0]decan-3-one (CXIII), prepared by chromic acid oxidation of dihydroguaialol (CXII).

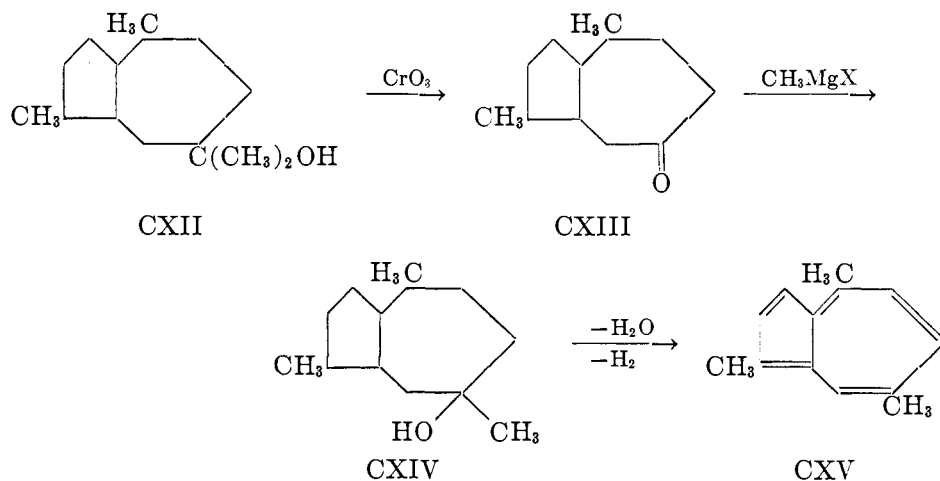

1,4,7-Trimethylazulene

A partial synthesis of guaiazulene is here possible by use of an isopropyl Grignard reagent with CXIII. In an analogous manner the synthesis of tetra-substituted azulenes should be possible starting with a vetivone (XI) (page 134).

A number of azulenes have been prepared from aromadendrene and its reaction products (197). In addition to guaiazulene, mentioned earlier, and its rearrangement product *Se*-guaiazulene, Treibs and Barchet have prepared 5-isopropylazulene, 7-isopropyl-1-methylazulene, and, by rearrangement, 5-isopropyl-2-methylazulene from aromadendrene. Ozonization of aromadendrene (CXVa) gives apoaromadendrone (CXVb), which on reduction gives apoaromadendrol (CXVc). Dehydration of CXVc gives apoaromadendrene (CXVd), which on low-temperature dehydrogenation gives 7-isopropyl-1-methylazulene (CXVe). At dehydrogenation temperatures above 300°C ., 5-isopropyl-2-methylazulene (CXVf) is obtained along with 7-isopropyl-1-methylazulene.

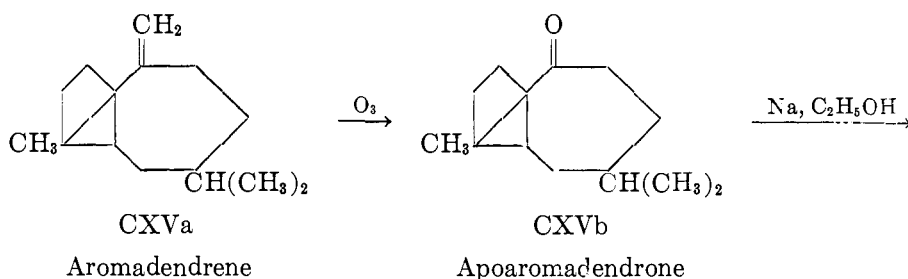

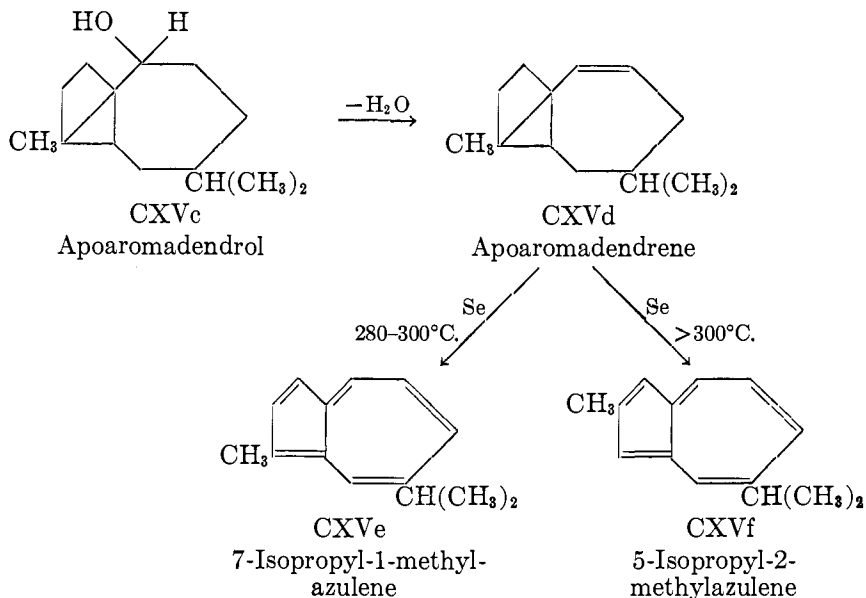

Apoaromadendrone (CXVb) adds a molecule of hydrochloric acid, which it splits off spontaneously to give isoapoaromadendrone (CXVg). The last-named compound can be ozonized to give a diketone (CXVh), which can be reduced to the diglycol (CXVi). Dehydration and dehydrogenation of the diglycol give 5-isopropylazulene (CXVj).

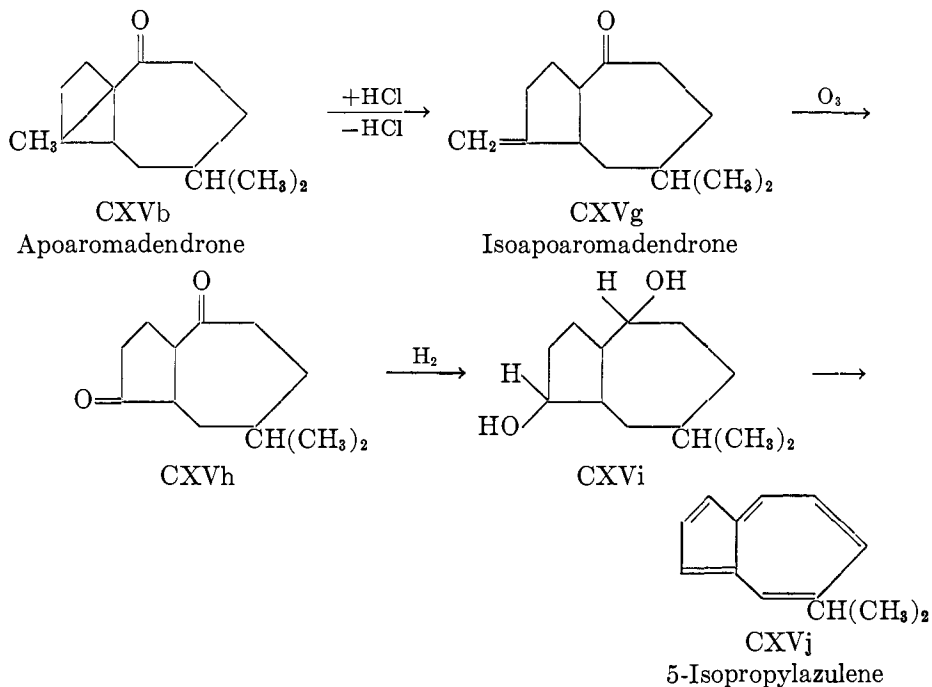

It is of interest that the above spontaneous splitting out of hydrochloric acid, CXVb \rightarrow CXVg, does not take place in the addition of the acid to aromadendrene (CXVa). In this case alcoholic alkali is necessary, and this reagent on the dihydrochloride (CXVk) gives isoaromadendrene (CXVI). The structure of isoaromadendrene as shown in CXVI may not be correct with respect to the position of the double bonds. On dehydrogenation isoaromaden-

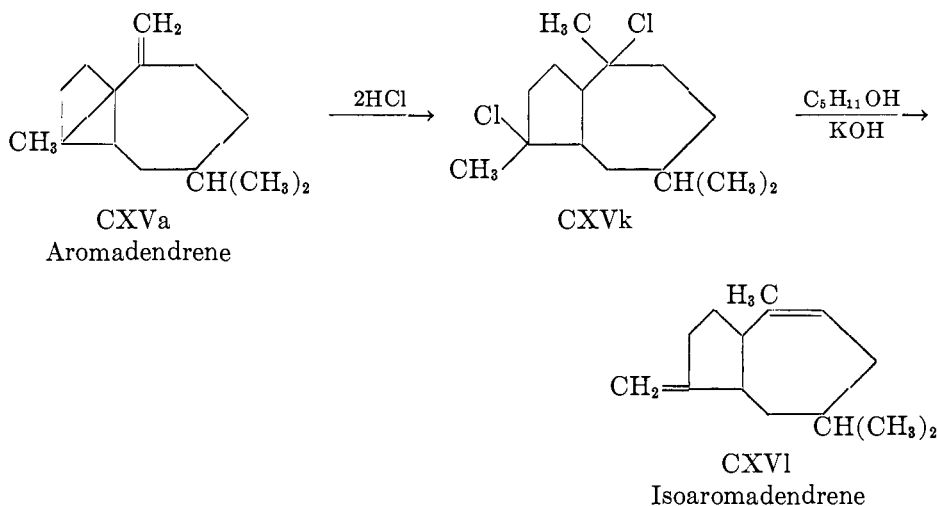

dre (CXVI) gives guaiazulene or a mixture of guaiazulene and *Se*-guaiazulene, depending on the temperature. It should be emphasized that the use of formula CXVa for aromadendrene should not be construed to show a preference among the various possible structures (see page 138).

Treibs (196a) prepared 5-methyl-, 5-ethyl-, and 5-phenylguaiazulenes (CXVo; R = CH₃, C₂H₅, and C₆H₅) from α -kessyl ketone (CXVn). The ketone was obtained by oxidizing α -kessyl alcohol. Asahina (10) described eight isomeric kessyl ketones and their corresponding alcohols, and Treibs (196a) obtained an even greater number. Hence some idea of the complexity of this series may be obtained. In determining the structure of α -kessyl ketone the azulenes obtained from it were of great value.

Chromic acid oxidation of α -kessyl ketone gives a diacid; therefore the keto group must be in the ring. α -Kessyl alcohol gives guaiazulene on dehydrogenation; hence it is apparent that the keto group must be at one of the corresponding unsubstituted ring positions: namely, the 2-, 3-, 5-, 6-, or 8-position. Since the spectra of the alkylguaiazulenes obtained on reaction of a Grignard reagent with α -kessyl ketone are shifted toward the longer wave lengths (see page 186), it is apparent that all of the positions except 3 and 5 are excluded from consideration. The 3-position may be excluded, since vigorous dehydrogenation with selenium of the product of phenylmagnesium bromide and α -kessyl ketone gives a phenylguaiazulene whose spectrum shows no violet shift. Hence there can be no appreciable amount of 2-phenylguaiazulene present and the phenyl group, and therefore the keto group of α -kessyl ketone, must be at the 5-position.

Other evidence for the structure of α -kessyl alcohol is given in the original reference (196a).

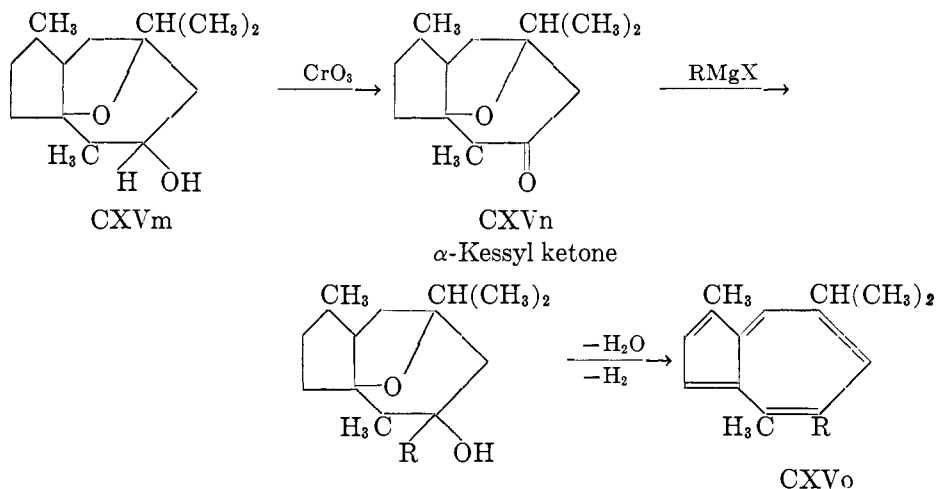

F. DEHYDROGENATION PROCEDURES

This subject has been reviewed by Plattner (115), but it will be discussed here briefly with regard to azulene synthesis. It will be noted from the foregoing that virtually all azulene syntheses involve dehydrogenation of a cycloheptano-cyclopentanone (which is usually partially unsaturated) to give the conjugated system of the azulenes.

Dehydrogenations to azulenes have been carried out using sulfur, selenium, and the platinum metals. Sulfur may be used at about 200–220°C.; hence it is valuable in cases where migration of substituents on the azulene nucleus must be avoided (see Section III, G). It is usually used in stoichiometric amounts, an excess being detrimental. Palladium or platinum, usually used on charcoal, are employed at temperatures above 300°C. and generally give purer products than are obtained by sulfur dehydrogenation. However, at these temperatures migration of substituents is possible and must be taken into account in working up reaction mixtures. Palladium and platinum are equally good, though palladium usually gives more side reactions. The activity of noble metal catalysts usually decreases as follows: metal on activated charcoal > metal on asbestos > metal as "black." Selenium is used at temperatures intermediate between those used for sulfur and for platinum metals, usually at about 280–300°C. Consequently it does sometimes permit migration of substituents, but does not give as clear cut a dehydrogenation as is obtained with platinum metals. Selenium is usually used in the calculated amount, though an excess is not detrimental.

Dehydrogenation methods vary widely. With sulfur, for example, the components are sometimes merely mixed and heated to the desired temperature (181). In other cases small amounts of sulfur are added to the material being dehydrogenated while the latter is being heated at the desired temperature (120). Addi-

tion of the hydrocarbon to heated sulfur usually results in no azulene being obtained (120).

Palladium has also been used in a variety of procedures. In some cases the compound is heated with 5 or 10 per cent palladized charcoal on an oil or metal bath at 300–330°C. (120). In many cases dehydrogenation is accomplished by distilling the hydrocarbon from palladium–charcoal by the use of a free flame. This gives good results only with high-boiling starting materials like the diazoacetic ester addition products. Another method that has been used for dehydrogenation with palladium involves dropping the hydrocarbon very slowly through

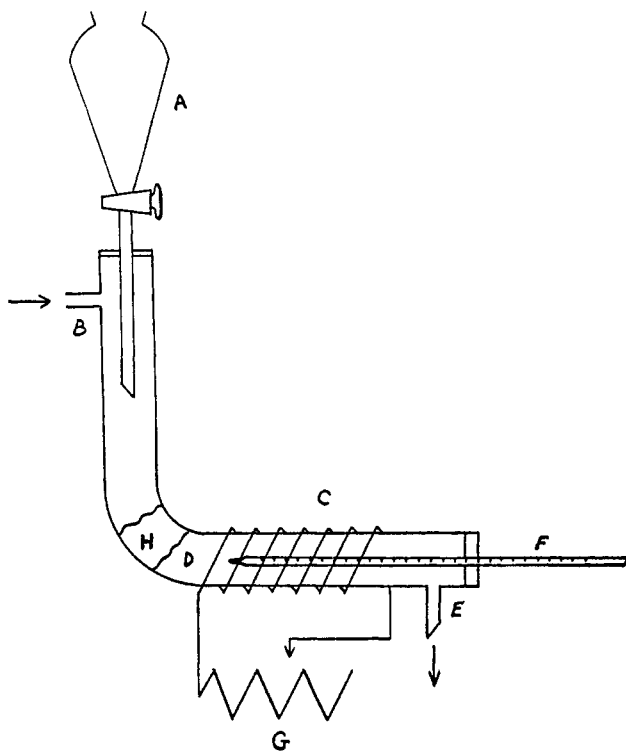

FIG. 1. Apparatus used in dehydrogenation by means of palladium–charcoal

a capillary onto the heated catalyst and collecting the dehydrogenation mixture in a collar blown on the reaction vessel. This method usually necessitates recycling of the undehydrogenated material three or four times (122).

A recent adaptation of the palladium dehydrogenation procedure has given excellent results in a number of laboratories (3, 101, 120, 124). A sketch of the type of apparatus used in Plattner's laboratory is given in figure 1. A modification of this apparatus has been described in a recent publication (43a).

In this apparatus the electrically heated tube (C) (the heating element generally continues up the vertical tube as well) is filled with 10 per cent palladium–charcoal on an asbestos carrier (D) and plugged loosely with glass wool (H).

The material to be dehydrogenated is added dropwise in a stream of nitrogen entering at B at a rate of about 30 liters per hour. The temperature, read at F, is controlled by a rheostat G. The product leaves the dehydrogenation tube at E. It is collected in a side-arm flask fitted with a spiral dry-ice trap to catch vapors and colloidal particles. Dehydrogenation yields in excess of 10 per cent have been obtained with this apparatus (120). It is to be expected that construction of a vapor-phase dehydrogenation apparatus operated with an evacuated system will give even better yields.

G. MIGRATION OF SUBSTITUENTS ON THE AZULENE NUCLEUS

The first instance of the migration of substituents on the azulene nucleus was encountered in the dehydrogenation of guaiol to guaiazulene, although it was not recognized as such at the time. Dehydrogenation of guaiol with selenium gave a different azulene from that obtained with sulfur, and the spectrum of the product made it probable that a migration of the methyl group from the 1- to the 2-position had occurred either during or after dehydrogenation. Recent work (120) would seem to indicate that migration takes place on the aromatic azulene nucleus, after dehydrogenation.

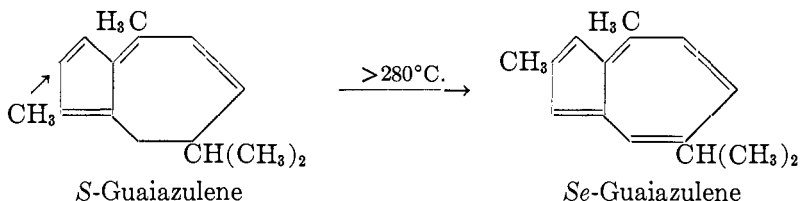

The isoguaiazulene of Šorm (181) may be identical with one of the components of the *Se*-guaiazulene mixture (118) (see page 139), since isoguaiazulene is obtained, mixed with guaiazulene, in the palladium dehydrogenation of δ -guaiene at 280–300°C. In the sulfur dehydrogenation at 225–235°C. Šorm obtained only guaiazulene.

The azulene nucleus has been found to be similar to the naphthalene system in many ways (73a, 85, 91, 143). Hence it is not surprising that migration of substituents from the 1- to the 2-position of naphthalene has also been reported to occur (86). Thus, dehydrogenation of α -phenyltetralin results in β -phenylnaphthalene (86). Heating of α -phenylnaphthalene alone likewise gives some β -phenylnaphthalene. A number of other α -substituted naphthalenes have been found to rearrange to the β -form on heating (103a). Similarly, 1-phenylindene has been found to rearrange to 2-phenylindene on heating (20, 87).

The most recent instance of the migration of substituents in the azulene nucleus occurred in the synthesis of 1-phenylazulene. In the first attempts to prepare this substance (147) dehydrogenation of the addition product of 1-phenylindan and diazoacetic ester, after saponification, resulted in only 2-phenylazulene being isolated as a crystalline product. Later the synthesis was re-investigated by another route (120), and it was found that the major product of the dehydrogenation was, in fact, 1-phenylazulene and that the 2-phenylazulene contaminant resulted from migration of the phenyl group. Repetition of the

I. AZULENES WITH FUNCTIONAL GROUPS

In addition to the azulencarboxylic esters (page 155) and the methoxy-substituted azulene (see table 1) whose syntheses have been described earlier, there is also an azulenealdehyde, lactaroviolin (page 139), and possibly also an azulencarboxylic acid (page 139), occurring in nature.

It is possible that lactaroviolin has one of the following structures (CXXIa, b, or c) based on what is very likely the structure of lactarazulene (see page 138).

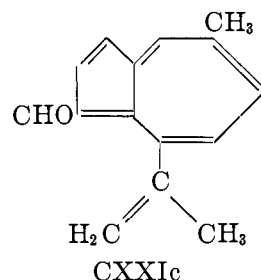
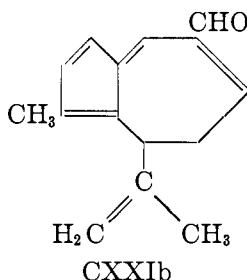
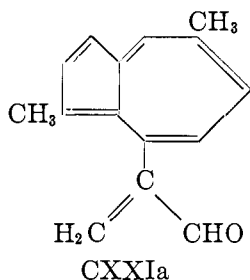

In the course of converting carboxyl groups to alkyl groups by the Grignard route (page 156), Plattner and Roniger (146) have prepared 6-acetyl-4,8-dimethylazulene (?) (CXXII) and 6-(2'-hydroxyisopropyl)-4,8-dimethylazulene (CXXIII). Plattner, Fürst, and Müller (142) have prepared 6-hydroxymethyl-1,2-benzazulene (CXXIV), and Plattner, Fürst, and Somerville (130) have

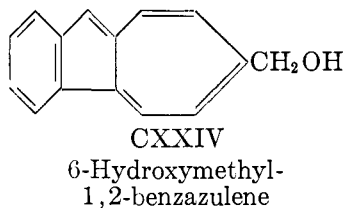
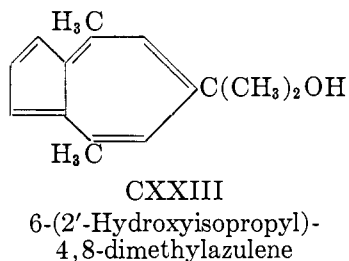
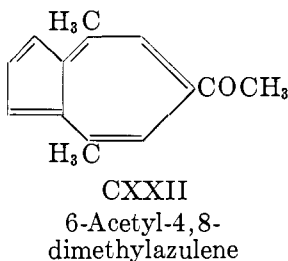

prepared 6-hydroxymethyl-2-methylazulene by the lithium aluminum hydride reduction of 2-methylazulene-6-carboxylic acid.

It should be emphasized that synthesis of azulencarboxylic esters by the diazoacetic ester route, utilizing indans other than those substituted in the 4- and 7-positions, almost invariably results in mixtures of acids. This consideration must be taken into account in evaluating any of the published work on the synthesis of azulencarboxylic acids (128a).

Arnold (6, 7) has prepared two tetrahydro(hydroxymethyl)azulenes (CXXVa, b) by the Bouveault-Blanc reduction of the corresponding tetrahydroazulene-carboxylic esters. Dehydrogenation of these hydroxymethyl compounds gives

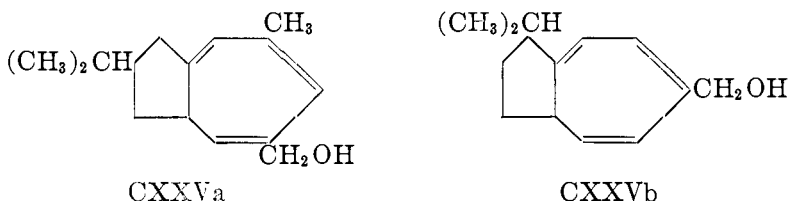

the corresponding oxygen-free alkylazulenes.

Recently, work has been undertaken in the direct substitution of azulenes. Thus, Anderson and Nelson (3) have reported the preparation of 1-azuleneazobenzene in brown-black needles from azulene and benzenediazonium chloride in the presence of sodium acetate. In acid solution a red compound is formed which gives the azo compound on the addition of base.

Anderson and Nelson (3) reported the synthesis of a 4-hydroxyazulene, a red oil, by the dehydrogenation of bicyclo[5.3.0]-1-decen-2-one. These authors also have prepared 1-bromo- and 1,3-dibromoazulenes (position of substituents inferred from spectra) by the action of *N*-bromosuccinimide on azulene. Action of acetic anhydride on azulene in the presence of aluminum chloride in carbon disulfide gave a mixture of 1-acetyl- and 1,3-diacetylazulenes. With an excess of acetic anhydride mainly diacetylazulene was obtained in red needles. With stannous chloride as a catalyst and azulene in excess, pure 1-acetylazulene was reported to be obtained (3).

A nitroazulene (probably the 1-nitro derivative) was obtained in red needles by Anderson and Nelson on treating azulene with cupric nitrate and acetic anhydride (2). Alkylation of azulenes by the Friedel-Crafts reaction was not very successful. Azulene with mercuric chloride is reported to give a bischloromercuriazulene, probably 1,3 (3).

Reduction of mononitroazulene gave good yields of *N*-acetylazulylamine. Reduction of azuleneazobenzene, followed by acetylation, gave the same *N*-acetylazulylamine in low yield. This was identical with the product obtained from 1-acetylazulene by the Beckmann rearrangement of its oxime. Free aminoazulenes proved to be very unstable (3). These results support the prediction of Brown (23) (see page 182) that electrophilic substitution would take place in the 1-position.

J. TABLE OF AZULENES

Table 2 contains data on the azulenes and certain of their derivatives.

IV. PROPERTIES OF AZULENES

A. CHEMICAL BEHAVIOR OF AZULENES

The azulenes are a rather reactive group of compounds, much more so than the naphthalenes with which they are isomeric. The azulenes decompose very

TABLE 2
Physical properties of azulenes and derivatives

NO.	NAME	MELTING POINT	COLOR AND CRYSTAL FORM	DERIVATIVE AND MELTING POINT		REFERENCES	VISIBLE SPECTRA (a)
		°C.			°C.		m μ
1...	Azulene	98.5-99	Blue platelets; solution violet	TNB ^(b) Trotlylate	166.5-167.5 99.5-100	(52, 109, 114, 143, 190, 204)	697f 662s 633f 603s 579f 554s 533s 513s 495s 479s
2...	1-Methyl-		Blue oil	TNB Picrate	160-161 (154) 134-135	(114, 116, 150)	738f 705m 669f 638m 607f 582s 558s 537s
3...	1-Isopropyl-			TNB	114-115	(7)	738f 705m 666f 636m 607f 580s 558s 537s
4...	1-Phenyl-	54	Blue needles	Bis-TNB	88.5-89	(120, 147)	737ff 663ff 606f 556s
5...	2-Methyl-	47-48	Blue-violet platelets	TNB Picrate	140-141 130-131	(150)	676f 650m 634s 623s 613f 601s 592m 579m 570f 561m 551s 543s
6...	2-Ethyl-	44-45	Blue needles	TNB Picrate	107 110-111	(117, 122, 204)	676f 661s 651s 637m 625m 615f 603s 591s 580s 571f 561f 552s 542s 534s 524s 518s
7...	2-n-Propyl-			TNB	118-119	(122)	677f 664m 651m 637m 625m 614f 603s 592s 581s 570f 562f 551s 542s 533s
8...	2-Isopropyl-	31	Blue-violet plates	Bis-TNB	113-114	(132)	677f 664s 651s 637s 624m 614ff 603s 592s 581s 570f 562f 552ss 543ss 534ss 525ss
9...	2-Phenyl-	230	Blue-violet plates	2, 4, 7-Trinitroflu- orenone ^(c)	199-200	(120, 147)	688ff 675f 662s 646m 633f 622ff 611m 599s 588s 577f 569m 546ss 537ss
10...	4-Methyl-		Blue oil; solution blue-violet	TNB Picrate	177.5-178 144	(109, 136)	680f 645s 618ff 591m 568f 545s 525s 507s
11...	4-Ethyl-			TNB Picrate Styphnate	147.5 128.5 123	(109)	

12..	4-Phenyl-			TNB Picrate	86-87 80-81	(109)	
13..	5-Methyl-	27	Blue	TNB Picrate	146 (151.5) 119	(4, 6, 131, 136, 144, 180)	717f 679m 650f 616s 591m 566s 545ss
14..	5-Isopropyl-			TNB	134 (118-119.5) (122-123)	(126, 197) (56a)	715f 677m 648f 616s 590m 566s 544s
15..	6-Methyl-	83	Blue-violet	TNB Picrate	141 137 (125)	(131, 148, 182)	681f 647m 617f 590m 567f 544m 524s 505ss
16..	1,2-Dimethyl-	58-59	Blue needles	TNB Picrate	166-167 129-130	(150)	753f 720f 683mf 648mf 625m 591ms 572s 544s
17..	1,3-Dimethyl-	54		TNB Picrate	164-166 134-136	(123)	770f 750m 705f 672m 638f 610m 582s 558s 539s 517ss
18..	1,4-Dimethyl-		Blue oil	TNB Picrate	177-178 142-143	(141, 149)	721f 691s 652ff 625ms 595f 571s 548s 529s 509ss
19..	4,8-Dimethyl-	69-70	Blue-violet	TNB Picrate	179-180 157-158	(65, 145)	666f 631s 606f 581m 558f 536s 517s 502s
20..	1,8-Dimethyl-		Blue oil	TNB	173-174	(126)	724f 689m 657f 626m 599f 575s 550ss 529ss
21..	2,6-Dimethyl-	97	Violet	TNB	167	(185)	660M 634M 612I 600M ^(d) 588M 580M 568I 558M 550M 524I
22..	4,6-Dimethyl-		Violet oil	TNB	143	(184)	662f 628s 601f 575s 555f 533s
23..	2-Ethyl-4-methyl-		Violet oil	TNB	112	(204, 206)	670f 646.5m 632s 611.5f 590.5s 576m 562.5f ^(e)
24..	1-Isopropyl-6-methyl-			TNB	98-98.5	(7)	725m 688f 658m 627s 599m 577m 553ss

TABLE 2—Continued

NO.	NAME	MELTING POINT	COLOR AND CRYSTAL FORM	DERIVATIVE AND MELTING POINT		REFERENCES	VISIBLE SPECTRA ^(a)
		°C.			°C.		
25..	5-Isopropyl-2-methyl-			TNB	(110-111) 127	(126, 197)	689f 662m 624f 600s 578f 553ss 536ss
26..	1-Isopropyl-5(7)-methyl-			TNB	149-150	(7)	759f 720f 648mf 649m 621m 593m 569s 546s
27..	6-Isopropyl-2-methyl-	43-44				(126)	660f 637m 621ss 611s 601ff 590s 580m 568s 559f 550f 541s 532s
28..	2-Isopropyl-5-methyl-		Blue-violet oil	TNB	110-111	(9)	689f 657s 627f 599s 572f
29..	7-Isopropyl-1-methyl-			TNB	141	(197)	
30..	1,2,3-Trimethyl-		Blue	TNB Picrate	181-182 160	(123)	756m 727f 699s 678f 654s 631s 613m 595s 577s 561s 546ss 531ss
31..	1,3,5-Trimethyl-			TNB	166	(206)	685f 650ff 621f 594m 573s
32..	1,6,8-Trimethyl-			TNB	163-164	(205)	706ff 672f 640ff 611mf 586mf 561s 539s 517ss 484ss 456ss
33..	2,4,8-Trimethyl-(?) (Pyrethazulene)			TNB	167-168	(171)	
34..	1,4,7-Trimethyl-		Blue	TNB	177-178	(141)	739f 702s 667f 636s 608mf 582s 559s 538ss
35..	1-Isopropyl-3,7-dimethyl-			TNB	147.5	(206)	680f 649ff 618f 598m 574s
36..	6-Isopropyl-1,4-dimethyl-			TNB	151-151.5	(127, 128)	707f 675s 638m 612s 585m 561s 539s
37..	7-Isopropyl-1,4-dimethyl- (Guaiazulene)	31.5 (29.5)	Blue	TNB Picrate Styphnate TNT ^(c)	148-149 (151) 122 105-106 89	(16, 89, 109, 127, 128, 155, 167)	732f 699s 661f 631s 603f 577s 556s

38..	2-Isopropyl-4,8-dimethyl- (Vetivazulene)	32-33	Violet needles	TNB Picrate Styphnate TNT	151.5-152 121.5-122 95-96 80.5-81	(27, 109, 110, 179, 190)	647s 628s 587f 544f
39..	2-Ethyl-4,8-dimethyl-		Violet	TNB	118-119	(204)	
40..	2-Isopropyl-5,7-dimethyl-		Blue	TNB	117-118	(9)	709f 672s 639f 606s 581f
41..	7-Isopropyl-2,4-dimethyl- (Se-Guaiazulene)		Blue-violet	TNB Styphnate Picrate TNT	153-154 98-99 114-115 71-72	(9, 109, 162)	665I 600M 580I <u>565M^(d)</u>
41a.	Isoguaiazulene		Blue-violet	TNB	167.5	(181)	705I 685I 639M 623M ^(d) 607M <u>585M 550I</u>
42..	1-Isopropyl-4,7-dimethyl-		Blue	TNB	117-118	(146, 203)	Identical with that of guaiazu- lene
175 43..	6-Isopropyl-4,8-dimethyl-	39	Red-violet	TNB Picrate	173-173.5 145	(146)	651m 617s 593ff 569s 547f 526ss 509ss
43a.	6-(2'-Hydroxyisopropyl)-4,8- dimethyl-	54	Violet	TNB	170	(146)	658s 599f 575s 552m 530ss
43b.	6-Isopropenyl-4,8-dimethyl-	70-71	Blue-violet	TNB	132	(146)	Vague band at 600 Dark zone at 580-550 m μ
43c.	6-Acetyl-4,8-dimethyl-(?)		Blue in solution	Semicarbazone	212 (approx.)	(146)	
43d.	2-Ethyl-8-methoxy-4-methyl-		Lilac-blue			(204)	640ff 620f 587.5s ^(e) 579.5ss 544s
44..	1,3,4,8-Tetramethyl-	88-89	Blue	TNB	194	(129)	746f 710m 678f 648m 618f 595s 573s 550s
45..	1,2-Benzazulene	176	Green plates; blue solution	TNB Picrate Trotylate	155 110 105.5-106.5	(58, 101, 119, 124, 193, 195, 198)	790ff 742ff 712s 696-682ff 666s 632-613ff 593s 569-556ff 540s 517s 497ss 476ss
46..	1,2-Indeno-(2',1')-	230		TNB	141	(135, 158)	

TABLE 2—Continued

NO.	NAME	MELTING POINT	COLOR AND CRYSTAL FORM	DERIVATIVE AND MELTING POINT		REFERENCES	VISIBLE SPECTRA ^(a)
		°C.			°C.		
47..	1,8-Trimethylene-	60 (51)		TNB Picrate	168 (161-163) 131	(126, 198)	718f 685m 649ff 621m 594f 569m 546s 525ss 506ss
48..	4,5-Benzazulene		Blue	TNB TNT	160-161 120	(29, 102, 126)	
49..	4,5-Tetramethylene-		Blue oil	TNB	128-129.5	(126)	707f 691ss 669m 641ff 607m 588ff 559ss 542ss
50..	5,6-Benzazulene	159.5	Violet plates	TNB	137.5	(28, 124)	681f 665s 645m 631s 621-607ff 582f 570-550ff 531s 511s
51..	5,6-Tetramethyleneazulene	71	Blue plates with violet tinge	TNB	116-117	(124)	696ff 658m 628ff 600m 575f 550s 530ss
9/1 52..	6-Carbethoxy-1,2-benz- azulene	176 (d) (169-170)	Green plates; blue solution	TNB	115-116	(126, 142, 193, 195)	853M 815M 793M 740M ^(d) 720M 665M 600M 545I
53..	1,2-Benzazulene-6-carboxylic acid	260-261				(126, 142)	Same as above but maxima less sharp
54..	6-Hydroxymethyl-1,2-benz- azulene	173-174	Green crystals; violet-blue solution			(126, 142)	770I 760I 730M 710I ^(d) 680I 650M 595M 575I 562M 550M 495I
55..	<i>α</i> -Carbethoxy-1,8-trimethyl- ene-		Green oil; blue solution	TNB	118	(198)	
56..	4,8-Dimethylazulene-6- carboxylic acid	265 (approx.)		Semi-TNB	215 (d) (approx.)	(145)	740m 669f 610f
57..	6-Carbomethoxy-4,8-di- methyl-	66.5	Green plates	TNB Picrate	127-128 103	(145)	744ff 673f 640s 612m
58..	6-Carbethoxy-4,8-dimethyl-	60-60.5	Blue plates	TNB Picrate	92 82-83	(145)	747ff 673f 641ss 613m

58a.	Azulene-5-carboxylic acid	206-207	Violet	TNB S-Benzylthiuronium salt	152-153 164	(128a)	679ff 645s 617ff 588m 566f 542s 523s
58b.	5-Carbomethoxy-	40-41	Violet platelets	TNB	122	(128a)	680f 645s 618ff 588m 566ff 544s 523s 503ss
58c.	5-Carbomethoxy-	30-31	Violet-blue			(128a)	680f 644s 618ff 588f 566ff 543s 522s 505ss
59..	Azulene-6-carboxylic acid	225-227 * (d)	Green needles	TNB S-Benzylthiuronium salt	182-183 192	(66, 128a)	750ff 698ff 665s 632f 580ss
60..	6-Carbomethoxy-2-ethyl-(*)			TNB	71	(128a, 204)	668.5 643 630.5 <u>619(*)</u> 608.5 586 575.5 <u>563</u> (Stronger bands are underlined)
60a.	6-Carbomethoxy-	126		TNB	113	(128a)	735ff 700ff 663f 635f 605s 580ss
60b.	2-Methylazulene-5-carboxylic acid	171	Violet-gray	TNB S-Benzylthiuronium salt	157-158 168	(128a)	658f 634s 618s 601ff 587ss 578s 565s 552ff 533ss 516ss
60c.	5-Carbomethoxy-2-methyl-	82-83	Blue-violet	TNB	116	(128a)	658f 634s 618s 601ff 587ss 578ss 566s 552ff 533ss 516ss
61..	6-Carbomethoxy-2-methyl-(*)		Blue-violet oil	TNB	65-65.5	(126, 130, 142)	657.5f 634.5s 616.5ss 599f 578m 565-542ff (diffuse) 553s 517ss
62..	2-Methylazulene-6-carboxylic acid(*)	250-251	Green needles	Semi-TNB S-Benzylthiuronium salt	217-218 182	(128a, 130)	753ff 726s 679ff 617ff 572ss
62a.	6-Carbomethoxy-2-methyl-	117-118	Dark blue platelets	TNB	137-138	(128a)	754ff 726m 679ff 654s 628f 616s 572s
63..	2-Methylazulene-6-carboxamide(*)	212-214				(130)	664m 641.5? 605.5f 583? 552f

TABLE 2—Continued

NO.	NAME	MELTING POINT	COLOR AND CRYSTAL FORM	DERIVATIVE AND MELTING POINT	REFERENCES	VISIBLE SPECTRA ^(a)
		°C.		°C.		m μ
64.	6-Hydroxymethyl-2-methyl- ^(*)	124–125	Violet		(130)	654ss 601m 561m
65.	6-Carbethoxy-2-isopropyl-4,8-dimethyl-		Blue		(204)	762–713.5 672–647 618.5–598
66.	1,2,3-Trimethylazulene-6-carboxylic acid ^(*)	245 (d) (approx.)			(123)	731f 655f 595f 548s
67.	Chamazulene		Blue oil	TNB 133–133.5 Picrate 120 Styphnate 92	(95, 114, 167, 186, 212)	735f 698s 664f 633s 605m 578s 557s 538s
67a.	Lactarazulene		Blue oil	TNB 122–123	(69, 133, 211, 212, 213)	691 666 631 602 577
68.	Lactaroviolin	53		HCl addition product 83–84 (d) Compound with 1,3-dimethylbarbituric acid 228	(69, 133, 211, 213, 214)	634 580 539 503 Hydrogenated product: 733f 695m 661f 630m 602f 573m 555s
69.	Nitrile of lactaroviolin				(214)	659 631 599 575 552
70.	Verdazulene	90	Green		(69, 211, 213)	636 607 580
71.	Linderazulene	105–106		Picrate 133 (d) Styphnate 130 (d)	(78)	
72.	Protazulene		Orange		(214)	
72a.	Chamazulenogen		Orange		(186)	

73..	7-Isopropyl-1,4,5-trimethyl- (5-Methylguaiazulene)		Blue	TNB	139-140	(196a)	See reference
74..	5-Ethyl-7-isopropyl-1,4-di- methyl- (5-Ethylguaiazulene)		Blue	TNB	147-148	(196a)	See reference
75..	7-Isopropyl-1,4-dimethyl-5- phenyl- (5-Phenylguaiazulene)		Blue	TNB	142-143	(196a)	See reference
76..	5-Isopropenyl-			TNB	86-87	(142)	715f 677m 648ff 614f 588f 563m 543s 522ss
77..	5-Isopropenyl-2-methyl-			TNB	99-100	(142)	689f 662m 624f 599s 578f 554ss 533ss
78..	6-Isopropenyl-2-methyl-	113-114				(142)	660f 636m 622s 611s 600ff 590s 581m 568s 559f 550f
79..	4-Hydroxy-(*) (4-Azulol)		Red oil			(3)	
80..	1-Acetyl-(*)		Maroon oil			(3)	655M 595M <u>550M</u> ^(d)
81..	1,3-Diacetyl-	189-190 119-120	Red needles Maroon needles	Semicarbazone	184-185	(2)	498M ^(d)
82..	1-Bromo-(*)		Green-blue oil			(3)	736M 697M 662M 632M ^(d) <u>605M</u> 590M 586M
83..	1,3-Dibromo-	76-77 88-89	Green plates Blue needles			(3)	755M 730M 686M 675M ^(d) <u>658M</u> <u>625M</u>
84..	1-Nitro-	98-99	Red needles			(2)	572M 532M ^(d)
85..	1-Azuleneazobenzene	120-121	Black needles			(3)	

TABLE 2—Concluded

NO.	NAME	MELTING POINT	COLOR AND CRYSTAL FORM	DERIVATIVE AND MELTING POINT	REFERENCES	VISIBLE SPECTRA ^(a)
		°C.				<i>mμ</i>
86..	<i>N</i> -Acetyl-1-azulylamine	146-147	Green-blue		(3)	625M ^(d)
87..	1,3(?) -Dichloromercuri-azulene	Does not melt <300	Blue-gray		(3)	

(a) Absorption bands have the following designations for decreasing intensities: ff f mf m ms s ss.

(b) TNB = trinitrobenzene.

(c) This derivative was prepared by Dr. David Kritchevsky.

(d) M = maximum; I = inflection. This spectrum was measured on the Beckman instrument. The underlined value is the highest absolute maximum.

(e) This spectrum may have to be corrected 10 *mμ* toward the shorter wave lengths.

(f) TNT = trinitrotoluene.

(g) Product impure.

slowly on standing in air, owing to oxidation, and their decomposition is accelerated by light. Oxidation disrupts the conjugated-double-bond system, as seen by the color change from blue or violet to green, yellow, or brown (10). However, about 95 per cent of pure azulene can be recovered from a sample of guaiazulene after standing for five months. In contrast, cycloöctatetraene polymerizes rapidly in air (216).

Chamazulene reacts readily with bromine, nitrogen trioxide, and nitrosyl chloride. Hydrochloric acid in acetic acid reacts with cubebazulene (guaiazulene) to give a yellow amorphous product (79). Shaking guaiazulene with powdered sodium or potassium gives a grey-brown powder from which the azulene may be regenerated (17). This product is of undetermined structure. Other reactions of azulenes have already been cited in connection with its derivatives (page 171).

Azulenes are indifferent to alkali and soluble in strong acids. The latter property is a valuable one and is employed for the purification and characterization of azulenes. Recently (137, 138) Craig partition (31) between strong acids and organic phases has been utilized as a criterion of the purity and identity of azulenes. The determination of the acid concentration (or Hammett function (46)) for which the distribution coefficient is unity ($\log K' = 0$) is a new physical method for determining the purity of azulenes. Amounts of azulene of less than 1 mg. can be determined in this manner, although for accuracy it is preferable to use larger quantities.

The larger the size of the alkyl group on the azulene, the higher the concentration of acid required to effect solution. Thus, all the higher alkylazulenes have higher acid concentration values than methylazulene. Azulene itself is exceptional, in that it has a very low basicity. This concept is useful, since azulenes with different alkyl substituents at the same position cannot be distinguished spectroscopically. This is also a good method for locating possible exocyclic double bonds in substituted azulenes, since when these are present the linear relationship between $\log K'$ (distribution coefficient) and H_0 (Hammett function) disappears.

Utilization of this partition method for determination of the homogeneity of samples, in accordance with the Craig procedure (31), results in something like the curves in figure 2 if the sample is inhomogeneous and the curves in figure 3 if the sample is pure. It can thus be seen that separation of closely related isomers is possible by this procedure.

In an extension of the above work (137), a method and apparatus have been developed for the stepwise dilution of the concentrated sulfuric acid solution of azulenes with water (138), so that first the more weakly basic azulenes are taken into the carbon tetrachloride phase. The quantities to be obtained in a stepwise extraction of a single azulene by this method can be calculated in the form of an elution curve and compared with that actually obtained. This method has proved especially useful for the separation of 4- and 5-methylazulenes.

Hydrogenation of azulenes proceeds rapidly to what appears to be an octahydro compound and slowly to the decahydro derivatives. The hydrogenation

curve breaks at 3.6 double bonds; hence the compounds described as octahydroazulenes in the literature are probably mixtures of hexahydro- and decahydroazulenes (89). In the hydrogenation of guaiazulene reaction will not go beyond the equivalent of the octahydro compound unless the platinum catalyst is reactivated by shaking in air (162).

Potassium permanganate in acetone attacks azulenes slowly (10). Under more drastic oxidation the molecule disintegrates to small fragments like acetic acid, oxalic acid, carbon dioxide, acetone, and isobutyric acid (162). Heating guaiazulene to 250°C. in a sealed tube produces no change. At 320–340°C. migration of the methyl group from the 1- to the 2-position takes place (Section III, G). At 350–430°C. a rearrangement of the nucleus from azulene to naphthalene results (Section III, H).

Brown (23) has reported that approximate quantum-mechanical calculations of the polarization energies and π -electrons of the azulene molecule indicate that electrophilic substitution will take place in position 1, while nucleophilic

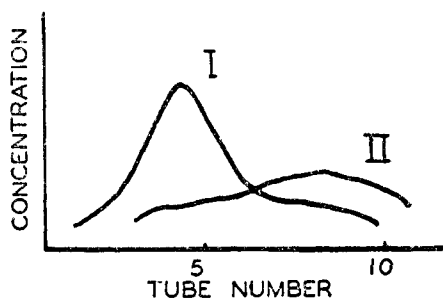

FIG. 2

FIG. 2. Mixture of 4- and 5-methylazulenes: curve I, toluene layer; curve II, 40 per cent sulfuric acid layer.

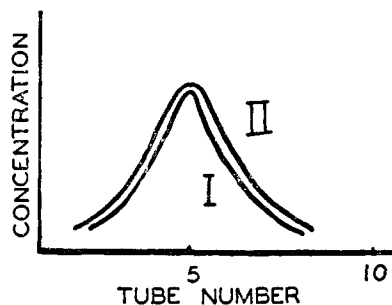

FIG. 3

FIG. 3. Pure guaiazulene: curve I, calculated values; curve II, experimental values

substitution will take place at position 4. Calculations of polarization energy show that radical substitution will occur at position 4 as well. Bond orders and bond lengths have also been calculated, the longest bond being between atoms 9 and 10. This would be anticipated from examination of the two resonating structures, neither of which shows a double bond at position 9–10. The predictions regarding substitution have been confirmed experimentally (2, 3).

B. PHYSICAL PROPERTIES OF AZULENES

The spectra of azulenes, their most significant physical property, are discussed in Section IV, D. Intensive investigations of the visible, ultraviolet, and infrared spectra of azulenes have been made. It is of interest that determinations of the crystalline structure of azulene have also been made by x-ray diffraction (42, 91).

In a discussion of the theory of color in organic compounds Sklar (178) stated that several structural formulas can be written for a colored compound, since the molecule usually contains a system of conjugated unsaturation having two

or more resonance (Kekulé) distributions. The color is attributed to absorption bands corresponding to transitions between the levels which arise from resonance among these different possible structures. Sklar has calculated the position of the longest wave-length absorption band of azulene from the heat of hydrogenation, without using any optical data. The result agrees well with experiment: calculated, 6900 Å.; found, 7000 Å.

From theoretical considerations Wheland and Mann (209) calculated the dipole moment of azulene to be 1–2 D. Experimental work showed the dipole moment to be 1.0 ± 0.05 D; hence the experiment essentially supports theoretical prediction. The dipole moment of azulene is unusually large for an unsubstituted hydrocarbon. Wheland (208) has also calculated the resonance energy of azulene.

The heats of combustion of the isomers guaiazulene (7-isopropyl-1,4-dimethylazulene) and cadalene (5-isopropyl-3,8-dimethylnaphthalene) have been determined by Perrotet (108) and found to be 2022.9 and 1993.4 kcal., respectively. The difference of 29.5 kcal. is far greater than the experimental error. It has been estimated, from the heats of formation from atoms of carbon and molecules and atoms of hydrogen, that in passing from the naphthalene to the azulene nucleus the bonding energy diminishes by almost 8 per cent. Molecular models show that the strain is greater in the azulene nucleus than in naphthalene.

The resonance energy of azulene has been calculated by Heilbronner and Wieland (51) to be 43 kcal. per mole, utilizing the approximation method of Sklar. Using the heat of combustion values of Perrotet (108), Heilbronner and Wieland have found the resonance energy to be 46 kcal. per mole.

An important physical property of the azulenes is their adsorption on alumina (22, 109). This characteristic has made possible the isolation and purification of azulenes, as well as the easy decomposition of trinitrobenzene–azulene complexes. Usually the ratio of azulene to alumina employed is about 1:30. However, if a ratio of 1:200 or 300 is used, there is obtained a system capable of separating very closely related azulenes—hence a method equal in power to partition chromatography.

The increase in adsorbability on alumina of the compounds hydrocarbon, ester, ketone, alcohol, and acid can be shown (146) with the following compounds: 6-isopropyl-4,8-dimethylazulene (CXXVI), 6-carbethoxy-4,8-dimethylazulene (CXXVII), 6-acetyl-4,8-dimethylazulene (CXXVIII), 6-(2'-hydroxyisopropyl)-4,8-dimethylazulene (CXXIX), and 4,8-dimethylazulene-6-carboxylic acid (CXXX). This series was observed earlier in the carotenoids (219).

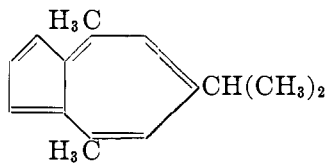

CXXVI

6-Isopropyl-4,8-dimethylazulene

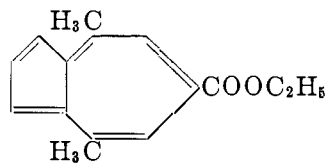

CXXVII

6-Carbethoxy-4,8-dimethylazulene

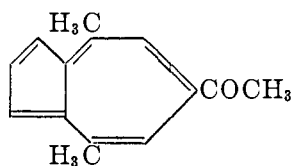

CXXVIII

6-Acetyl-4,8-dimethylazulene

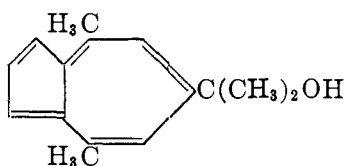

CXXIX

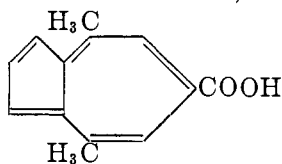
6-(2'-Hydroxyisopropyl)-
4,8-dimethylazulene

CXXX

4,8-Dimethylazulene-6-carboxylic acid

The differential adsorbability is also noted with the trinitrobenzene derivatives of these compounds. Up to the ester (CXXVII) the difference is sufficient to allow separation of the trinitrobenzene from the azulene in the complex. With the ester, however, large amounts of alumina must be used to effect separation from the trinitrobenzene. The picrate of the ester is much easier to split, since the picric acid is much more strongly adsorbed on the alumina. The alcohol (CXXIX) requires ether to move it on the alumina. Hence the trinitrobenzene is eluted before the azulene. The acid (CXXX) is so strongly held that the strongest eluate, methanol (petroleum ether < benzene < ether < acetone < methanol), only widens the band somewhat. Acetic acid must be used to remove the azulencarboxylic acid, but some aluminum salts come along with it (146).

C. PHARMACOLOGY OF AZULENES

The anti-inflammatory action of camomile oil (*Matricaria chamomilla* L.) has been found to be due to the azulene present (54, 55). This has been confirmed by the fact that camomile extracts have no such physiological action until they are distilled to form the azulene (100). It has further been demonstrated (65) that extracts of *Chamomilla discoidea* L. are devoid of any anti-inflammatory action, owing to the absence of azulene precursors in this plant. Pommer (152) has reported that only chamazulene shows any anti-inflammatory action, but other investigators have found some other azulenes to be effective (1, 8, 187). The pharmacological action was studied by means of rat, rabbit, cat, and human eyes that had been inflamed by mustard oil.

Certain azulenes have been tested against rat leprosy by Wagner-Jauregg (204), but they were found to be ineffective. Azulenes have also been found to be devoid of vitamin A activity (162).

Willstaedt and Zetterberg (215) have studied the inhibition of *Mycobacterium tuberculosis* by lactaroviolin and have found it to inhibit growth when present in a culture medium at a concentration of 0.31 millimole per liter.

Blazsò (17a) has reported some success in treating bronchial asthma in infants and children by the use of a 2 per cent chamazulene solution administered by intramuscular injection.

D. SPECTRA OF AZULENES

1. Visible spectra

One of the most important aids for the characterization and identification of azulenes is their visible spectrum. Even some of the very early investigators of the azulenes supplemented their work with spectral measurements (53, 57, 200, 218). A systematic study of the spectra of azulenes was first made by Plattner and Pfau (143), and this was followed by a number of later papers (114, 117, 123, 129, 134, 136, 146, 190). The visible spectra of azulenes have been measured principally by means of a grating spectroscope in which the intensity of the bands had to be estimated visually. Plattner and Heilbronner (134) made parallel measurements of a number of monomethylazulenes with a visual instrument and also with a photometer which was capable of measuring absolute intensities of bands. The agreement between the visual and photometer readings was usually better than $\pm 3 \text{ m}\mu$. From this work the authors concluded that the visual method was more convenient than the photometer procedure, and the former continued to be employed.²

It is possible to compute the change in the visible spectrum which results from polysubstitution by utilizing the wave-length or wave-number differences between the bands of azulene and its monomethyl derivatives. The difficulty with this method is that different values are obtained, depending on whether the longest wave-length bands, the bands with the greatest absolute intensities, or the average of the differences of all the band wave lengths or wave numbers are employed as reference standards. However, a few instances will show that these calculations are at least of qualitative value in predicting the absorption maxima of unknown azulenes.

In going from azulene to 1-methylazulene there is a shift in the visible spectrum of about $+36 \text{ m}\mu$ or -800 cm.^{-1} Substitution at the 2-position gives a shift in the opposite direction of about $-20 \text{ m}\mu$ or $+450 \text{ cm.}^{-1}$ At the 4-position there is again an alternation of effect, so that the shift amounts to about $-15 \text{ m}\mu$ or $+350 \text{ cm.}^{-1}$ Substitution in the 5-position causes a shift of about $+15 \text{ m}\mu$ or -350 cm.^{-1} The 3-, 8-, and 7-positions naturally are equivalent to the 1-, 4-, and 5-positions, respectively. In the 6-position substitution results in a shift of about $-15 \text{ m}\mu$ or $+350 \text{ cm.}^{-1}$ It may be seen, therefore, that azulenes substituted in the 2-, 4-, 6-, or 8-position would tend to be violet in color, while those substituted in the 1-, 3-, 5-, or 7-position would be pure blue. Reference to table 2 shows that this is generally the case. These results are summarized in figure 4.

² It has recently been found that for azulenes other than those in spectral group I (see page 186) the spectra should be measured on an instrument like the Beckman spectrophotometer, since maxima so obtained differ somewhat from those obtained with the grating spectroscope.

Utilizing these values for a calculation of the spectral shift of 1,3,4,8-tetramethylazulene, compared with azulene, gives a value of $(2 \times +36) + (2 \times -15) = +42 \text{ m}\mu$ or $(2 \times -800) + (2 \times +350) = -900 \text{ cm.}^{-1}$ Since the observed average shift of the principal bands of the tetrasubstituted azulene amounts to about $+44 \text{ m}\mu$ or -1000 cm.^{-1} , it can be seen that the direction and relative magnitude of the shift are predictable.

Looking at spectral group I (figure 5) it can be seen that all of the compounds above azulene have their spectra shifted toward the longer wave lengths and hence toward the lower wave numbers. This is to be anticipated, since most of these compounds are substituted at position 1 (or 3), and this substitution results in about twice the shift caused by substitution at any other position. 1,3-Dimethylazulene would be expected to lie at the top of the group, since it is substituted at both long-wave-length shifting positions. There are exceptions to this rule in the case of azulene-carboxylic acids, and generalizations must be withheld for these compounds until more have been characterized. Thus, the

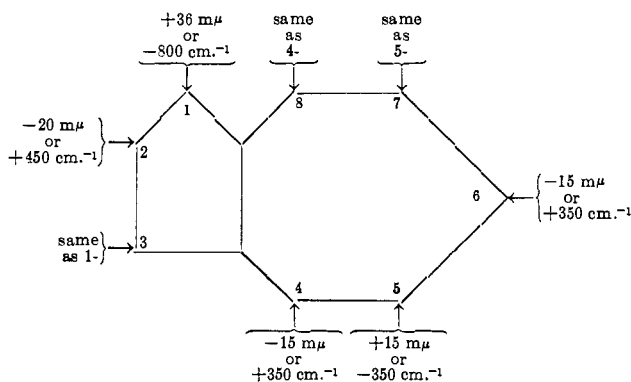

FIG. 4

4,8-dimethyl-6-carboxylic acid derivatives, judging from the spectrum of azulene-6-carboxylic acid, for which $\Delta\lambda$ compared to azulene is about $-16 \text{ m}\mu$, should have their spectra displaced about $(2 \times -15) + (-15)$ or about $-45 \text{ m}\mu$. The actual displacement is about $36 \text{ m}\mu$ in the opposite direction, and the cause of this effect is not known at present. It should be noted that the individual effect of a 6-carboxyl group, in azulene-6-carboxylic acid, is about equal to that of a 6-alkyl group.³ In general, the spectrum seems to be independent of the size of the alkyl substituent but highly dependent on its position of attachment in the nucleus.

The visible spectra of groups I and II are given in figures 5 and 6. The miscellaneous group III includes 1,2-dimethyl-, 2,6-dimethyl-, 1,2,3-trimethyl-,

³ Recent work gives more examples of the anomaly illustrated by the case of 4,8-dimethylazulene-6-carboxylic acid cited above. Therefore it must be concluded that comparison of alkyl groups with carboxyl groups, in respect to the spectral shifts resulting from their presence, must be utilized with caution, since all of the factors involved are apparently not yet known.

1,6,8-trimethyl-, 2-ethyl-8-methoxy-4-methyl-, 1,2-benz-, 5,6-benz-, 6-hydroxymethyl-1,2-benz-, 6-hydroxymethyl-2-methyl-, 6-carbethoxy-2-isopropyl-4,8-dimethyl-, and 1,2,3-trimethyl-6-carboxyazulenes, lactaroviolin, verdazulene, the nitrile of lactaroviolin, and 6-carbethoxy-1,2-benzazulene.

Table 3 lists the polysubstituted compounds of spectral groups I and II, with the exception of the 4,8-dimethylazulene-6-carboxylic acid derivatives mentioned earlier, showing the calculated and found displacements of the average of all

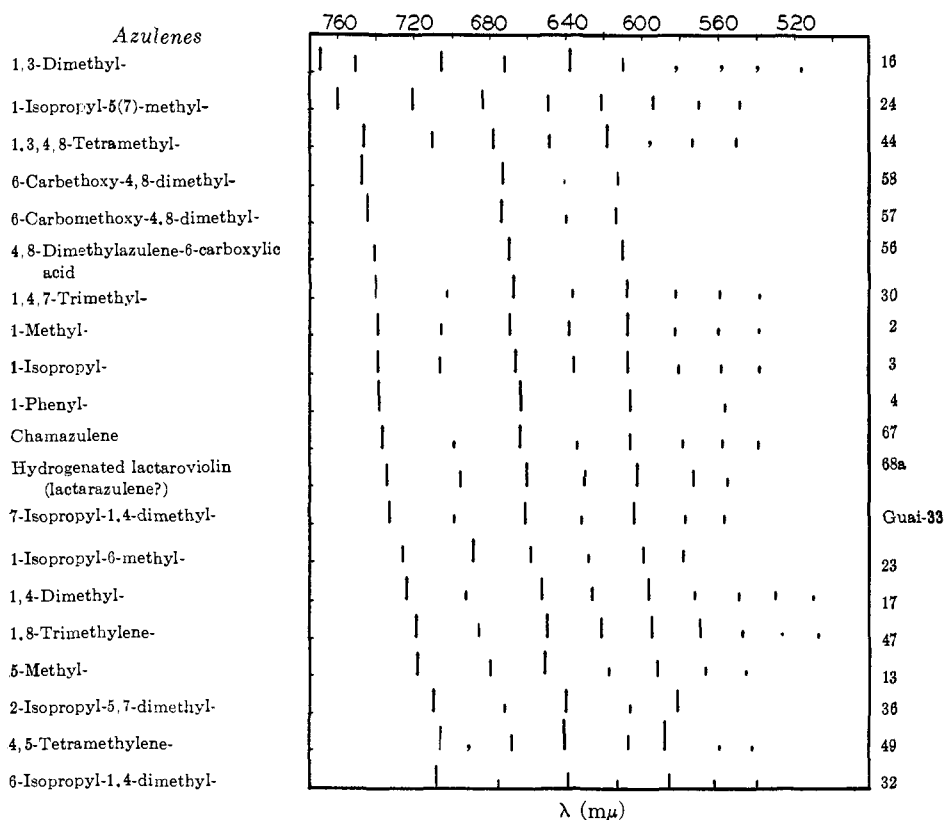

FIG. 5. Spectral group I

of the spectral lines, based on the values obtained for monomethylazulenes (figure 4).

It may be seen from table 3 that contributions of the individual alkyl groups are remarkably additive and that there is excellent agreement between calculated and observed values of the spectral shift in polysubstituted azulenes, considering that the experimental error of the measurements may be $\pm 3 m\mu$. The exceptions, as noted earlier, are mainly in 4,8-dimethylazulene-6-carboxylic acid and its esters.

The large discrepancies between the observed and calculated shifts in the

Azulenes

FIG. 5. Spectral group I (concluded)

Azulenes

FIG. 6. Spectral group II

spectra of 1,3,5-trimethyl- and 1-isopropyl-3,7-dimethylazulenes are very likely due to a migration of the alkyl group to the 2-position and an anomalous reaction of the diazoacetic ester. The only other large discrepancy is in the case of 6-(2'-hydroxyisopropyl)-4,8-dimethylazulene, in which the effect of the exocyclic hydroxyl group on the spectrum is difficult to estimate. It is even ques-

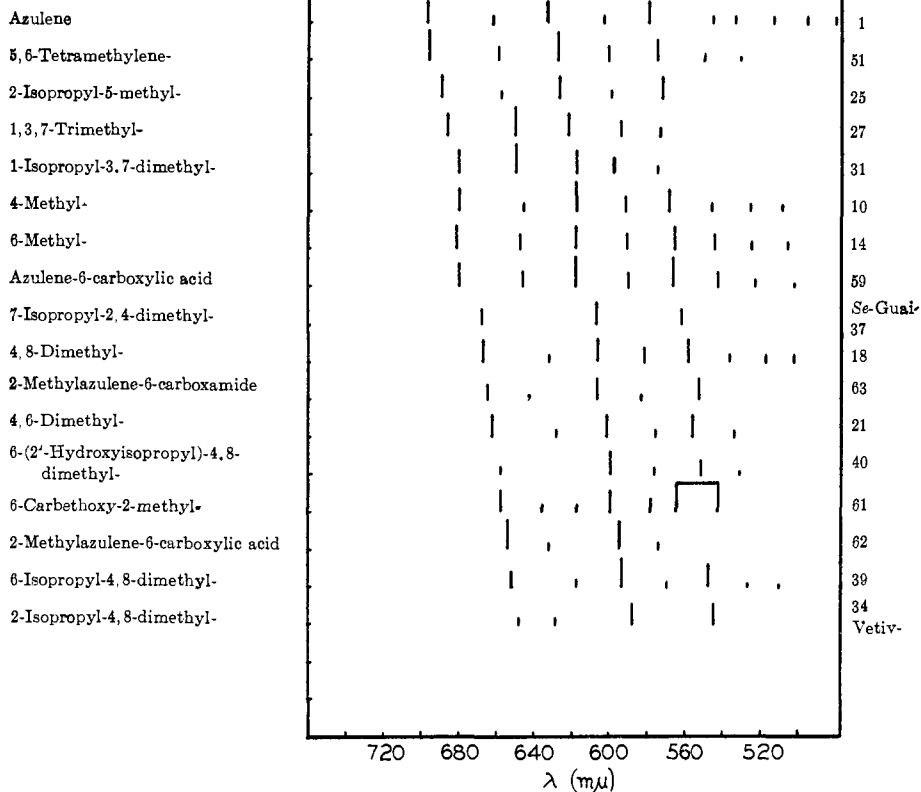
tionable whether this compound belongs to spectral group I. However, in this case too the calculated and observed shifts are of the same order of magnitude.

In spectral group II there is fair agreement between calculated and observed shifts of spectra, when compared with the spectra of monosubstituted azulenes.

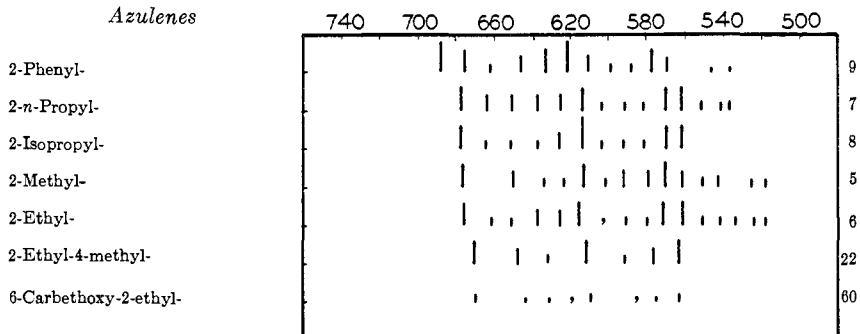
TABLE 3
Calculated and observed shifts in the ultraviolet spectra of azulenes

COMPOUND	SPECTRAL SHIFT	
	Calculated	Found
	$m\mu$	$m\mu$
1,3-Dimethylazulene.....	+72	+72
1-Isopropyl-5(7)-methylazulene.....	+51	+50
1,3,4,8-Tetramethylazulene.....	+42	+44
1,4,7-Trimethylazulene.....	+36	+36
Chamazulene (if a 1,5,8-derivative).....	+36	+32
7-Isopropyl-1,4-dimethylazulene.....	+36	+29
1-Isopropyl-6-methylazulene.....	+21	+24
1,4-Dimethylazulene.....	+21	+20
1,8-Trimethyleneazulene*.....	+21	+18
6-Isopropyl-1,4-dimethylazulene.....	+6	+5
2-Isopropyl-5,7-dimethylazulene.....	+10	+9
4,5-Tetramethyleneazulene*.....	0	+7
5,6-Tetramethyleneazulene*.....	0	-3
2-Isopropyl-5-methylazulene.....	-5	-6
1,3,5-Trimethylazulene†.....	87	-11
1-Isopropyl-3,7-dimethylazulene†.....	+87	-13
Azulene-6-carboxylic acid.....	-15	-15
7-Isopropyl-2,4-dimethylazulene.....	-20	-24
4,8-Dimethylazulene.....	-30	-26
4,6-Dimethylazulene.....	-30	-32
6-Isopropyl-4,8-dimethylazulene.....	-45	-39
2-Isopropyl-4,8-dimethylazulene.....	-50	-46
2-Methylazulene-6-carboxamide.....	-35	-36
6-(2'-Hydroxy isopropyl)-4,8-dimethylazulene.....	-50	-34
2-Methyl-6-carbethoxyazulene.....	-35	-34
2-Methylazulene-6-carboxylic acid.....	-35	-38

* This compound is treated as a dialkyl derivative.

† This product may be a mixture containing a large amount of 1,2,6-trimethylazulene produced by migration of the methyl group (see Section III, G) and anomalous reaction of the diazoacetic ester (see Section III, B, 1). It is also possible that in the synthesis of the intermediate 1,3,5-trimethylindan (see p. 147) the Friedel-Crafts reaction with toluene gave appreciable amounts of 2-acetyltoiuene, so that subsequently 1,3,4-trimethylindan was obtained. Hence, after ring enlargement and migration of the 1- or 3-methyl group, 1,2,8- or 1,2,4-trimethylazulene would result. (Calculated for 1,2,6-, 1,2,8-, or 1,2,4-trimethylazulene: $\Delta\lambda = 1 m\mu$.)

It was seen (figure 6) that all of the simple 2-alkylazulenes, with the exception of 2-phenylazulene whose spectrum is shifted somewhat toward the longer wave lengths, show substantially identical spectra. For 6-carbethoxy-2-ethylazulene the calculated and observed shifts are -35 and $-23 m\mu$, respectively; for 2-ethyl-4-methylazulene the values are -35 and $-21 m\mu$.

In spectral group III it is difficult to make any comparisons, since most of the spectra are unlike that of azulene. Undoubtedly more azulenes with spectra of this type will have to be synthesized and their spectra measured accurately before any generalizations can be made.

It should be noted at this point that the classification of azulenes into spectral groups is a rather arbitrary one. It is made because many of the spectra do seem to fit into two distinct categories (ignoring group III, in which the spectra follow no particular pattern). The spectra of group I almost all consist of three pairs of alternating strong and weak bands, followed by a number of weak bands in many cases in the lower-wave-length regions. The spectra tend to become more compressed as they shift to the shorter wave lengths (see figure 5). The shift of the second strong band usually most closely approximates the average shift of the spectrum.

The spectra of the second group, of which the 2-alkylazulenes are the principal members, retain the first, third, and fifth strong bands of the first spectral group, but they contain a number of weak bands between these strong ones (see figure 6). The spectra of group II are also more highly compressed than those of group I, covering 120–160 $m\mu$, compared with 180–200 $m\mu$ for the spectra of group I.

The blending of the two groups is demonstrated by the fact that some of the lower members of group I could just as well be fitted into the bottom of group II. However, group II has been restricted in this review to those azulenes whose spectra unquestionably belong to this type.

There seems to be no set pattern to the effect of 6-substituents on the spectra of azulenes. Thus, 6-isopropenyl-4,8-dimethylazulene shows such a weak spectrum that comparison with other azulenes is impossible (146). On the other hand, 6-isopropyl-4,8-dimethylazulene has a well-defined visible spectrum that falls predictably into group I. In regard to its effect on spectra, substitution in the 6-position, as with substitution in the 2-position, often changes the spectrum completely. Substitution at all of the other positions, however, almost always contributes only the regular shift in the whole spectrum, as illustrated on page 186, without changing its basic character.

It is of interest (*cf.* page 156) that determination of the purity of a variety of samples of 5-methylazulene could be made by comparing the extinction coefficients of characteristic visible bands (136). The results obtained in this significant study are given in table 4.

The spectral data do not show whether the 5-methylazulene is contaminated with 4- or with 6-methylazulene. However, melting-point studies show that the trinitrobenzene (TNB) complexes of 4- and 5-methylazulenes when mixed show no depression. A mixture of the trinitrobenzene complexes of the 5- and 6-methylazulenes does show a depression of the melting point.

Recently (73a, 85) studies have been made of the spectral similarities between azulenes and their corresponding six-carbon-atom (naphthalene) ring isomers. Azulene (CXXXI), 1,2-benzazulene (CXXXII), 2-phenylazulene (CXXXIII), and indenoazulene (CXXXIV) were compared with their five

TABLE 4
Determination of the purity of samples of 5-methylazulene

NO.	COMPOUND	METHOD OF DEHYDROGENATION USED	MELTING POINT OF COMPLEX WITH TRI-NITRO-BENZENE	MAXIMUM (v)	ϵ	AMOUNT OF 5-METHYL-AZU-LENE	IMPURITY
			$^{\circ}\text{C}.$			per cent	
1a....	5-Methylazulene; Preparation of Šorm	Sulfur at 225 $^{\circ}\text{C}.$	142-143	15470	296	100	
1b....	From 3-methyl- <i>cis</i> -bicyclo[5.3.0]decene	Sulfur at 230 $^{\circ}\text{C}.$	140-141	15490	277	88	6-Methylazulene
1c....	From 3-methyl- <i>cis</i> -bicyclo[5.3.0]decene	Pd·C	139-140	15490	263	80	6-Methylazulene
1d....	From 3-methyl- <i>trans</i> -bicyclo[5.3.0]decene	Pd·C	139-140	15490	255	75	6-Methylazulene
1e....	Prepared by diazo-acetic ester method	Pd·C	150-151	15520	209	46	4-Methylazulene
1f....	Prepared by diazo-acetic ester method	Pd·C	149-150	15520	190	35	4-Methylazulene
2....	6-Methylazulene		140-141	15560	132	0	
3....	4-Methylazulene		174-175	15550	138	0	

1a: Šorm (180).

1b, 1c, 1d (131): These preparations correspond to compounds described as 6-methylazulenes by Arnold (4).

1e: Reference 144.

1f: Sample 1e recrystallized.

2: Reference 148.

3: Reference 109.

corresponding isomers, naphthalene (CXXXIa), phenanthrene (CXXXIIa), 2-phenylnaphthalene (CXXXIIIa), and benzofluorene (CXXXIVa) in part from 1730 to 7500 Å.

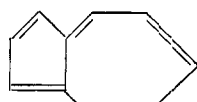

CXXXI
Azulene

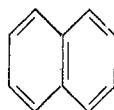

CXXXIa
Naphthalene

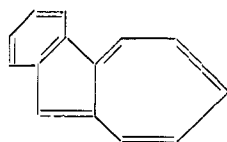

CXXXII
1,2-Benzazulene

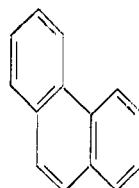

CXXXIIa
Phenanthrene

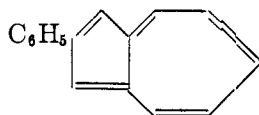

CXXIII
2-Phenylazulene

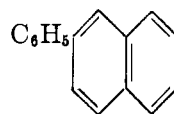

CXXIIIa
2-Phenyl-naphthalene

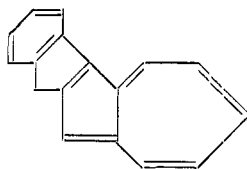

CXXIV
Indenoazulene

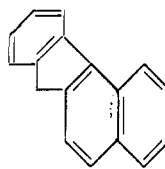

CXXIVa
Benzofluorene

The five band systems found in the azulenes seem to correspond with respect to intensity, vibrational structure, and sequence to the five found in their corresponding isomers, except that the former are all shifted toward lower frequencies. The lowest frequency band is shifted about $17,000\text{ cm.}^{-1}$ to the red in azulenes, which accounts for the color observed in these compounds. This low-frequency band has quite different properties from the lowest band in the blue compound pentacene. The other four bands in the azulenes are shifted about $8000\text{--}9000\text{ cm.}^{-1}$, as compared with the corresponding naphthalene isomers.

2. Ultraviolet spectra

The substitution of azulene at various positions does not cause as characteristic a change in the ultraviolet spectrum as is the case with the visible spectrum. Hence it is not possible to calculate the ultraviolet spectra of new azulenes from known data, as was done with the visible spectra. However, the ultraviolet spectra are of value in confirming the identity or nonidentity of azulenes, and therefore the spectra of a considerable number of azulenes have been measured in the ultraviolet region. Among the azulenes whose ultraviolet spectra have been measured by Plattner and Heilbronner (135) are azulene itself, 1-methyl-, 2-methyl-, 2-isopropyl-, 4-methyl-, 5-methyl-, 6-methyl-, 1,2-dimethyl-, 1,4-dimethyl-, 4,8-dimethyl-, 1,3,4,8-tetramethyl-, 2-phenyl-, and indeno-(2',1',2,1)azulenes. Other azulenes whose ultraviolet spectra have been measured include 2,6-dimethyl- and 4,6-dimethylazulenes (183), 1,8-trimethyleneazulene and its carboxylic ester (198), elemazulene (vetivazulene) (179, 190), 4,8-dimethylazulene-6-carboxylic acid and its esters (145), pyrethazulene (171), 1,2-benzazulene (101, 124, 198) and its carboxylic esters (198), *S*-guaiazulene (181, 197), *Se*-guaiazulene (181, 197), 7-isopropyl-1-methyl- (197), 7-isopropyl-, and 7-isopropyl-2-methylazulenes (197), and finally 5,6-benzazulene and 5,6-tetramethyleneazulene (124).

Heilbronner and Wieland (51) have also measured the ultraviolet absorption spectrum of azulene in the vapor phase. A few typical ultraviolet spectra are reproduced in figures 7 to 12 (124, 135).

The ultraviolet absorption spectra of the five monomethylazulenes show that substitution by alkyl groups shifts the spectrum toward longer wave lengths in

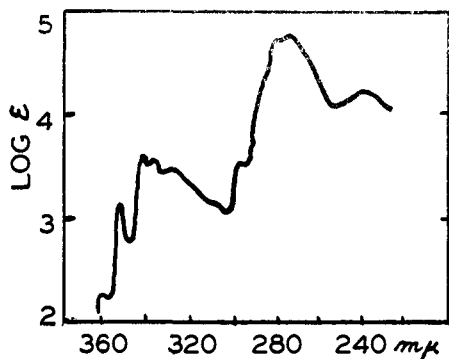

FIG. 7. Azulene

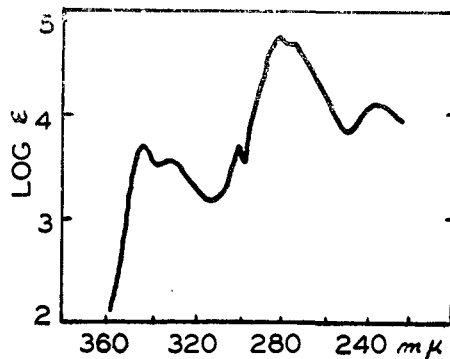

FIG. 8. 6-Methylazulene

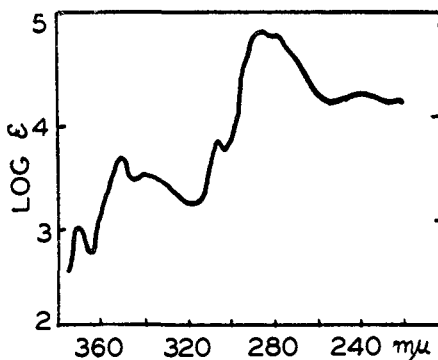

FIG. 9. 1,2-Dimethylazulene

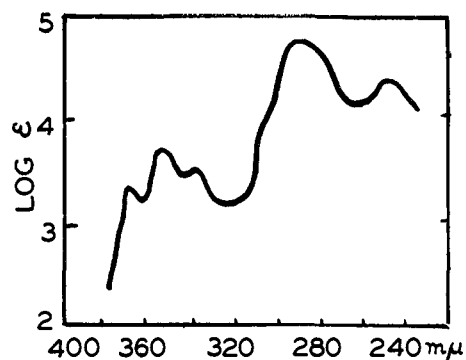

FIG. 10. 1,3,4,8-Tetramethylazulene

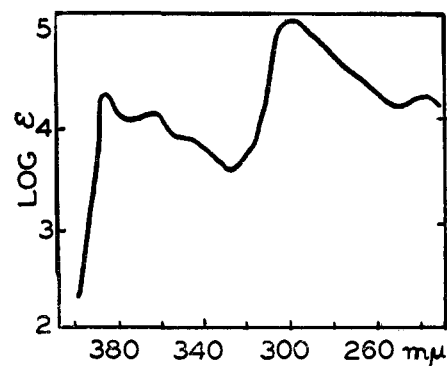

FIG. 11. 2-Phenylazulene

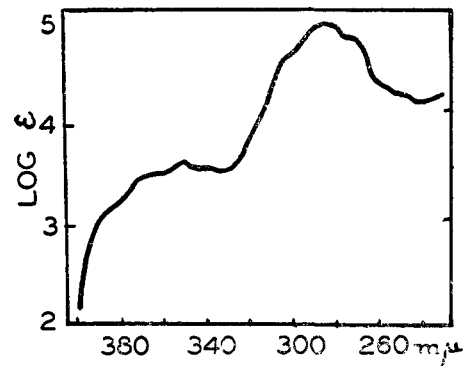

FIG. 12. 5,6-Benzazulene

all cases, in contrast to the influence of substitution on the visible spectrum in which the direction of the shift varies with the position substituted. There is a

distinct difference, however, in the ultraviolet spectra of azulenes substituted in the five-membered ring, as compared with the seven-membered ring. As in the visible spectra, the ultraviolet spectra of azulenes substituted in the seven-membered ring are similar to one another, and to azulene itself, while the ultraviolet spectra of 1- or 2-alkylazulenes are distinctly different from one another. The ultraviolet spectra of azulenes, as in the visible region, are virtually independent of the size of the substituents present, depending only on the position of attachment.

In the case of polysubstituted azulenes, the ultraviolet spectra show greater differences from that of azulene than is the case with the monosubstituted ones. In the case of ultraviolet spectra, however, the effect of substitution by individual alkyl groups is not additive, and the spectra of polysubstituted azulenes can therefore not be predicted in advance.

3. Infrared spectra

As with most other compounds, the infrared spectra of individual azulenes show sufficient differences to make these spectra a valuable aid in the identifi-

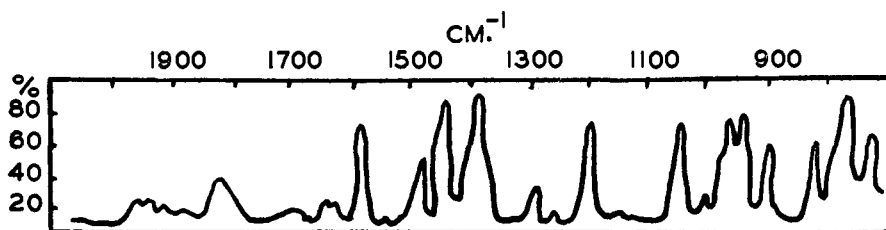

FIG. 13. Azulene

cation of azulenes, much more so than is the case with ultraviolet spectra. However, at this time not enough generalizations can be made regarding the effect of individual substitution on infrared spectra to make these spectra as valuable as those in the visible region. Infrared spectra of the following compounds have been measured: azulene, 1-methyl-, 2-methyl-, 5-methyl-, 6-methyl-, 1,3-dimethyl-, 1,4-dimethyl-, 4,8-dimethyl-, 4,8-dimethyl-6-isopropylazulenes, *S*-guaiazulene, and 4,8-dimethyl-6-carbethoxyazulene (41). Sorm (151, 181) has measured the infrared spectra of *S*-guaiazulene, isoguaiazulene (*Se*-?), chamazulene, and chamazulenogen, as well as of a number of hydrogenated derivatives. An infrared spectrum of 6-isopropyl-1,4-dimethylazulene (127) is also available. The infrared spectrum of azulene itself is reproduced in figure 13 (41).

A number of provisional generalizations regarding the infrared spectra of azulenes have been made (41). However, these assignments will probably have to be reviewed in the light of the great number of new azulene spectra which will shortly become available.

Grateful appreciation is expressed to Prof. Pl. A. Plattner and Dr. A. Fürst for supplying much of the data used in this review, for reading the manuscript,

and, most of all, for introducing the author to the fascinating subject of azulene chemistry. The author also wishes to express his thanks to Prof. H. N. Rydon and Dr. E. A. Braude for their helpful comments on the entire manuscript.

V. REFERENCES

- (1) ALBATH, W., AND HEUBNER, W.: Arch. exptl. Path. Pharmacol. **193**, 619 (1939).
- (2) ANDERSON, A. G., AND NELSON, J. A.: J. Am. Chem. Soc. **72**, 3824 (1950).
- (3) ANDERSON, A. G., AND NELSON, J. A.: Unpublished experiments.
- (4) ARNOLD, H.: Ber. **76**, 777 (1943).
- (5) ARNOLD, H.: Die Chemie **56**, 7 (1943).
- (6) ARNOLD, H.: Chem. Ber. **80**, 123 (1947).
- (7) ARNOLD, H.: Chem. Ber. **80**, 172 (1947).
- (8) ARNOLD, H., *et al.*: Pharmazie **4**, 220 (1949).
- (9) ARNOLD, H., AND SPIELMAN, W.: Chem. Ber. **83**, 28 (1950).
- (10) ASAHINA, Y., AND NAKANISHI, S.: J. Pharm. Soc. Japan **48**, 1 (1928); **52**, 2 (1932).
- (11) AUGSPURGER, L. F.: Science **42**, 100 (1915).
- (12) BAKER, W.: J. Chem. Soc. **1945**, 258.
- (13) BARBIER, P., AND BOUVEAULT, L.: Compt. rend. **119**, 281 (1894).
- (14) BERSUTSKI, W. P.: Bull. univ. états Asie centrale **22**, 119 (1938); Chem. Zentr. **1940**, II, 1451.
- (15) BIRRELL, K. S.: Chemistry & Industry **51**, 397 (1932).
- (16) BIRRELL, K. S.: J. Am. Chem. Soc. **56**, 1248 (1934).
- (17) BIRRELL, K. S.: J. Am. Chem. Soc. **57**, 893 (1935).
- (17a) BLAZSÖ, S.: Schweiz. med. Wochschr. **79**, 222 (1949); **81**, 110 (1951).
- (18) BRADFIELD, A. E., PENFOLD, A. R., AND SIMONSEN, J. L.: J. Proc. Roy. Soc. N.S. Wales **67**, 200 (1933).
- (19) BRAREN, W., AND BUCHNER, E.: Ber. **34**, 982 (1901).
- (19a) BRAUDE, E. A., AND FORBES, W. F.: Nature **168**, 874 (1951).
- (20) BRAUN, J. V., AND MANZ, G.: Ber. **62**, 1059 (1929).
- (21) BRIGGS, L. H., AND TAYLOR, W. I.: J. Org. Chem. **12**, 551 (1947).
- (22) BROCKMANN, H.: Ber. **74**, 73 (1941); **80**, 77 (1947).
- (23) BROWN, R. D.: Trans. Faraday Soc. **44**, 984 (1948).
- (24) BURLAGE, H. M., AND LYNN, E. V.: J. Am. Pharm. Assoc. **16**, 407 (1927).
- (25) CARTER, F. D., COPP, F. C., SANJIVA ROA, B., AND SIMONSEN, J. L.: J. Chem. Soc. **1939**, 1504.
- (26) CLARK, J. H.: Am. Perfumer **51**, 38 (1948).
- (27) COATS, R. R., AND COOK, J. W.: J. Chem. Soc. **1942**, 559.
- (28) COOK, J. W., MCGINNIS, N. A., AND MITCHELL, S.: J. Chem. Soc. **1944**, 286.
- (29) COOK, J. W., PHILIP, R., AND SOMERVILLE, A. R.: J. Chem. Soc. **1948**, 164.
- (30) COURTOT, C.: Ann. chim. [9] **4**, 168 (1915).
- (31) CRAIG, L. C.: J. Biol. Chem. **150**, 33 (1943); **155**, 519 (1944).
- (32) DEMJANOW, N. J.: J. Russ. Phys. Chem. Soc. **36**, 166 (1904); Chem. Zentr. **1904**, I, 1214.
- (33) DEMJANOW, N. J.: Ber. **40**, 4393 (1907).
- (34) DEMJANOW, N. J., AND LUSCHNIKOW, M.: J. Russ. Phys. Chem. Soc. **33**, 279 (1901); Chem. Zentr. **1901**, II, 335.
- (35) DENJANOW, N. J., AND LUSCHNIKOW, M.: J. Russ. Phys. Chem. Soc. **35**, 26 (1903); Chem. Zentr. **1903**, I, 828.
- (36) FAWORSKAJA, M. A.: J. Gen. Chem. (U.S.S.R.) **5**, 1804 (1935); Chem. Zentr. **1936**, I, 3925.
- (37) GADAMER, J., AND AMENOMIJA, T.: Arch. Pharm. **241**, 33 (1903).
- (38) GARNIER, R., AND SABETAY, S.: Ann. fals. et fraudes **28**, 585 (1935); Chem. Zentr. **1936**, I, 4085.

- (39) GENVRESSE, P., AND LANGLOIS, G.: *Compt. rend.* **135**, 1059 (1902).
- (40) GLADSTONE, J. H.: *J. Chem. Soc.* **17**, 2 (1864).
- (41) GÜNTHARD, HS.H., AND PLATTNER, PL.A.: *Helv. Chim. Acta* **32**, 284 (1948).
- (42) GÜNTHARD, HS.H., PLATTNER, PL.A., AND BRANDENBERGER, E.: *Experientia* **4**, 425 (1948).
- (43) GUENTHER, E. S., AND LANGENAU, E. E.: *J. Am. Chem. Soc.* **65**, 959 (1943).
- (43a) GÜNTHARD, H. H., SÜESS, R., MARTI, L., FÜRST, A., AND PLATTNER, PL.A.: *Helv. Chim. Acta* **34**, 959 (1951).
- (44) HAAGEN-SMIT, A. J.: *Fortschr. Chem. org. Naturstoffe* **5**, 40 (1948).
- (45) HAAGEN-SMIT, A. J., AND FONG, C. T. O.: *J. Am. Chem. Soc.* **70**, 2075 (1948).
- (46) HAMMETT, L. P.: *Physical Organic Chemistry*, p. 267. McGraw-Hill Book Company, Inc., New York (1940).
- (47) HARPER, S. H.: *Ann. Repts. on Progress Chem. (Chem. Soc. London)* **44**, 162 (1947).
- (48) HARRADENCE, R. H., AND LIONS, F.: *J. Proc. Roy. Soc. N. S. Wales* **72**, 284 (1939).
- (49) HAWORTH, R. D.: *Ann. Repts. on Progress Chem. (Chem. Soc. London)* **34**, 393 (1937).
- (50) HEILBRONNER, E., PLATTNER, PL.A., AND WIELAND, K.: *Experientia* **3**, 70 (1947).
- (51) HEILBRONNER, E., AND WIELAND, K.: *Helv. Chim. Acta* **30**, 947 (1947).
- (52) HENTZSCHEL, W., AND WISLICENUS, J.: *Ann.* **275**, 312 (1893).
- (53) HERZENBERG, J., AND RUHEMANN, S.: *Ber.* **58**, 2249 (1925).
- (54) HUEBNER, W., AND ALBATH, W.: *Arch. exptl. Path. Pharmacol.* **192**, 383 (1939).
- (55) HEUBNER, W., AND GRABE, F.: *Arch. exptl. Path. Pharmacol.* **171**, 329 (1933).
- (56) HIPPCHEN, H.: *Z. Naturforsch.* **1**, 325 (1946).
- (56a) HIPPCHEN, H.: *Fiat Report No. 1033* (January 14, 1947).
- (57) HOCK, K.: *Arch. Pharm.* **221**, 17 (1883).
- (58) HORN, D. H. S., NUNN, J. R., AND RAPSON, W. S.: *Nature* **160**, 829 (1947).
- (59) HÜCKEL, W.: *Ber.* **66**, 563 (1933).
- (60) HÜCKEL, W., AND SCHNITZSPAHN, L.: *Ann.* **505**, 274 (1933).
- (61) HÜTER, F.: *Deut. Parfüm. Ztg.* **28**, 153 (1942).
- (62) HUNTER, G. J. E.: *Chemistry & Industry* **51**, 394 (1932).
- (63) IKEDA, S.: *Sci. Papers Inst. Phys. Chem. Research (Tokyo)* **42**, 80 (1947); *Chem. Abstracts* **43**, 8102i (1949).
- (64) ITIKAWA, N., AND YAMASITA, T.: *J. Chem. Soc. Japan* **61**, 793 (1940).
- (65) JARETZKI, R., AND NEUWALD, F.: *Arch. Pharm.* **277**, 50 (1939).
- (66) JIRASEK, K.: *Thesis, Eidgenössische Technische Hochschule, Zurich, Switzerland*, 1950.
- (67) JOHNSON, W. S., *et al.*: *J. Am. Chem. Soc.* **67**, 1357, 1360, 1366 (1945).
- (68) KAISER, H., AND FREY, H.: *Deut. Apoth. Ztg.* **53**, 1385 (1938); **54**, 882 (1939); **57**, 155, 163 (1942).
- (69) KARRER, P. *et al.*: *Helv. Chim. Acta* **28**, 1176 (1945).
- (70) KIMURA, Y., AND HOSHI, M.: *J. Pharm. Soc. (Japan)* **53**, 145 (1933); *Chem. Zentr.* **1933**, II, 3145.
- (71) KIR'YALOV, N. P.: *J. Gen. Chem. (U.S.S.R.)* **13**, 145 (1943); *Chem. Abstracts* **38**, 1488^a (1944).
- (72) KIR'YALOV, N. P.: *Sovet. Botan.* **13**, 47 (1945).
- (73) KIR'YALOV, N. P.: *J. Gen. Chem. (U.S.S.R.)* **20**, 738 (1950); *Chem. Abstracts* **44**, 7811b (1950).
- (73a) KLEVENS, H. B.: *J. Chem. Phys.* **18**, 1063 (1950).
- (74) KOCH, K.: *Deut. Apoth. Ztg.* **55**, 758 (1940).
- (75) KOCH, K.: *Arch. Pharm.* **280**, 424 (1942).
- (76) KOMPPA, G.: *Kgl. Norske Videnskab. Selskabs Skrifter* **1933**, No. 1; *Chem. Zentr.* **1933**, II, 3121.
- (77) KOMPPA, G., AND NYMAN, G. A.: *Compt. rend. trav. lab. Carlsberg, Sér. chim.* **22**, 272 (1938); *Chem. Zentr.* **1938**, II, 326.

- (78) KONDO, H., AND TAKEDA, K.: *J. Pharm. Soc. Japan* **59**, 504 (1939); *Chem. Abstracts* **34**, 91⁹ (1940).
- (79) KREMERS, R. E.: *J. Am. Chem. Soc.* **45**, 717 (1923).
- (80) LAHEY, F. N., AND JONES, T. G. H.: *Univ. Queensland Papers, Dept. Chem.* **1**, No. 13, 4 pp. (1939); *Chem. Abstracts* **34**, 2133 (1940).
- (81) LATHROP, W.: *J. Am. Chem. Soc.* **62**, 132 (1940).
- (82) LEHMANN, A. J., AND LYNN, E. V.: *J. Am. Pharm. Assoc.* **19**, 1185 (1930).
- (83) LINSTEAD, R. P., AND MEADE, E. M.: *J. Chem. Soc.* **1934**, 935.
- (84) LONZA ELEKTRIZITÄTSWERKE: Swiss patent 240,614 (April 16, 1946); *Chem. Abstracts* **43**, 6644a (1949).
- (85) MANN, D. E., PLATT, J. R., AND KLEVENS, H. B.: *J. Chem. Phys.* **17**, 481 (1949).
- (86) MAYER, F., AND SCHIFFNER, R.: *Ber.* **76**, 67 (1934).
- (87) MAYER, F., AND SIEGLITZ, A.: *Ber.* **54**, 1397 (1921).
- (88) MEERWEIN, H.: German patent 579,309 (June 26, 1933); *Chem. Zentr.* **1933**, II, 1758.
- (89) MELVILLE, J.: *J. Am. Chem. Soc.* **55**, 2462, 3288 (1933).
- (90) MILLS, W. H., AND NIXON, I. G.: *J. Chem. Soc.* **1930**, 2510.
- (91) MISCH, L., AND VAN DER WYK, A. J.: *Compt. rend. soc. phys. hist. nat. Genève* **54**, 106 (1937); *Chem. Abstracts* **32**, 6523 (1938).
- (92) MITUI, S.: *Bull. Inst. Phys. Chem. Research (Tokyo)* **20**, 549 (1941); *Chem. Abstracts* **37**, 4071 (1943).
- (93) MOUDGILL, K. L.: *J. Soc. Chem. Ind.* **44**, T169 (1925).
- (94) MÜLLER, A.: *J. prakt. Chem.* [2] **151**, 233 (1938); **153**, 77 (1939).
- (95) MÜLLER, A.: *J. prakt. Chem.* [2] **156**, 179 (1940).
- (96) NAVES, Y. R.: *Parfums France* **1929**, 311.
- (97) NAVES, Y. R.: *Parfumerie* **1**, 70 (1943).
- (98) NAVES, Y. R.: *Helv. Chim. Acta* **31**, 1172 (1948).
- (99) NAVES, Y. R., AND PERROTTET, E.: *Helv. Chim. Acta* **23**, 912 (1940).
- (99a) NUNN, J. R.: *J. Chem. Soc.* **1950**, 1352.
- (100) NEUWALD, F.: *Süddeut. Apoth. Ztg.* **88**, 362 (1948); *Chem. Abstracts* **43**, 1490a (1949).
- (101) NUNN, J. R., AND RAPSON, W. S.: *J. Chem. Soc.* **1949**, 825.
- (102) NUNN, J. R., AND RAPSON, W. S.: *J. Chem. Soc.* **1949**, 1051.
- (103) NYMAN, G. A., AND MIKANDER, L.: *Suomen Kemistilehti* **14B**, 3 (1941); *Chem. Abstracts* **35**, 4755 (1941).
- (103a) ORCHIN, M., AND REGGEL, L.: *J. Am. Chem. Soc.* **70**, 1245 (1948).
- (104) PALFRAY, L. B., SABETAY, S., AND PETIT, P.: *Chimie et industrie* **43**, 367 (1940).
- (105) PELLINI, G.: *Ann. chim. applicata* **13**, 97 (1923); *Chem. Zentr.* **1923**, IV, 607.
- (106) PENFOLD, A. R.: *J. Proc. Roy. Soc. N. S. Wales* **61**, 337 (1928).
- (107) PENFOLD, A. R.: *J. Proc. Roy. Soc. N. S. Wales* **64**, 264 (1932).
- (108) PERROTTET, E., TAUB, W., AND BRINER, E.: *Helv. Chim. Acta* **23**, 1260 (1940).
- (109) PFAU, A. ST., AND PLATTNER, PL.A.: *Helv. Chim. Acta* **19**, 858 (1936).
- (110) PFAU, A. ST., AND PLATTNER, PL.A.: *Helv. Chim. Acta* **22**, 202 (1939).
- (111) PFAU, A. ST., AND PLATTNER, PL.A.: *Helv. Chim. Acta* **22**, 640 (1939).
- (112) PFAU, A. ST., AND PLATTNER, PL.A.: *Helv. Chim. Acta* **23**, 768 (1940).
- (113) PIESSE, D.: *Compt. rend.* **57**, 1016 (1864).
- (114) PLATTNER, PL.A.: *Helv. Chim. Acta* **24**, 283E (1941).
- (115) PLATTNER, PL.A.: *Newer Methods of Preparative Organic Chemistry*, pp. 21-59. Interscience Publishers, Inc., New York (1948).
- (116) PLATTNER, PL.A., AND BÜCHI, G.: *Helv. Chim. Acta* **29**, 1608 (1946).
- (117) PLATTNER, PL.A., AND FÜRST, A.: *Helv. Chim. Acta* **28**, 1636 (1945).
- (118) PLATTNER, PL.A., AND FÜRST, A.: Unpublished experiments.
- (119) PLATTNER, PL.A., FÜRST, A., CHOPIN, J., AND WINTELER, G.: *Helv. Chim. Acta* **31**, 501 (1948).

- (120) PLATTNER, PL.A., FÜRST, A., GORDON, M., AND ZIMMERMAN, K.: *Helv. Chim. Acta* **33**, 1910 (1950).
- (121) PLATTNER, PL.A., FÜRST, A., AND JIRASEK, K.: *Helv. Chim. Acta* **29**, 730 (1946).
- (122) PLATTNER, PL.A., FÜRST, A., AND JIRASEK, K.: *Helv. Chim. Acta* **29**, 740 (1946).
- (123) PLATTNER, PL.A., FÜRST, A., AND JIRASEK, K.: *Helv. Chim. Acta* **30**, 1320 (1947).
- (124) PLATTNER, PL.A., FÜRST, A., AND KELLER, W.: *Helv. Chim. Acta* **32**, 2464 (1949).
- (125) PLATTNER, PL.A., FÜRST, A., AND KELLER, W.: Unpublished experiments.
- (126) PLATTNER, PL.A., FÜRST, A., AND KELLER, W.: Unpublished experiments.
- (127) PLATTNER, PL.A., FÜRST, A., AND MARTI, L.: *Helv. Chim. Acta* **32**, 2452 (1949).
- (128) PLATTNER, PL.A., FÜRST, A., MARTI, L., AND SCHMID, H.: *Helv. Chim. Acta* **32**, 2137 (1949).
- (128a) PLATTNER, PL.A., FÜRST, A., MÜLLER, A., AND SOMERVILLE, A. R.: *Helv. Chim. Acta* **34**, 971 (1951).
- (129) PLATTNER, PL.A., FÜRST, A., AND SCHMID, H.: *Helv. Chim. Acta* **28**, 1647 (1945).
- (130) PLATTNER, PL.A., FÜRST, A., AND SOMERVILLE, A. R.: Unpublished results.
- (131) PLATTNER, PL.A., FÜRST, A., AND STUDER, A.: *Helv. Chim. Acta* **30**, 1091 (1947).
- (132) PLATTNER, PL.A., FÜRST, A., WYSS, J., AND SANDRIN, R.: *Helv. Chim. Acta* **30**, 689 (1947).
- (133) PLATTNER, PL.A., AND HEILBRONNER, E.: *Experientia* **1**, 233 (1945).
- (134) PLATTNER, PL.A., AND HEILBRONNER, E.: *Helv. Chim. Acta* **30**, 910 (1947).
- (135) PLATTNER, PL.A., AND HEILBRONNER, E.: *Helv. Chim. Acta* **31**, 804 (1948).
- (136) PLATTNER, PL.A., HEILBRONNER, E., AND FÜRST, A.: *Helv. Chim. Acta* **30**, 1100 (1947).
- (137) PLATTNER, PL.A., HEILBRONNER, E., AND WEBER, S.: *Helv. Chim. Acta* **32**, 574 (1949).
- (138) PLATTNER, PL.A., HEILBRONNER, E., AND WEBER, S.: *Helv. Chim. Acta* **33**, 1663 (1950).
- (139) PLATTNER, PL.A., AND LEMAY, L.: *Helv. Chim. Acta* **23**, 897 (1940).
- (140) PLATTNER, PL.A., AND MAGYAR, G.: *Helv. Chim. Acta* **24**, 1163 (1941).
- (141) PLATTNER, PL.A., AND MAGYAR, G.: *Helv. Chim. Acta* **25**, 581 (1942).
- (142) PLATTNER, PL.A., MULLER, A., AND FÜRST, A.: Unpublished experiments.
- (143) PLATTNER, PL.A., AND PFAU, A. ST.: *Helv. Chim. Acta* **20**, 224 (1937).
- (144) PLATTNER, PL.A., AND RONIGER, H.: *Helv. Chim. Acta* **25**, 590 (1942).
- (145) PLATTNER, PL.A., AND RONIGER, H.: *Helv. Chim. Acta* **25**, 1077 (1942).
- (146) PLATTNER, PL.A., AND RONIGER, H.: *Helv. Chim. Acta* **26**, 905 (1943).
- (147) PLATTNER, PL.A., SANDRIN, R., AND WYSS, J.: *Helv. Chim. Acta* **29**, 1604 (1946).
- (148) PLATTNER, PL.A., AND STUDER, A.: *Helv. Chim. Acta* **29**, 1432 (1946).
- (149) PLATTNER, PL.A., AND WYSS, J.: *Helv. Chim. Acta* **23**, 907 (1940).
- (150) PLATTNER, PL.A., AND WYSS, J.: *Helv. Chim. Acta* **24**, 483 (1941).
- (151) PLIVA, J., AND ŠORM, F.: *Collection Czechoslov. Chem. Commun.* **14**, 274 (1949).
- (152) POMMER, C.: *Arch. exptl. Path. Pharmacol.* **199**, 74 (1942).
- (153) POMMER, H.: *Angew. Chem.* **62**, 281 (1950).
- (154a) POWER, F. B., AND CHESTNUT, V. K.: *J. Am. Chem. Soc.* **47**, 1751 (1925).
- (154b) PRELOG, V., AND VATERLAUS, B.: *Helv. Chim. Acta* **33**, 2262 (1950).
- (155) RADCLIFFE, C. B., AND SHORT, W. F.: *J. Chem. Soc.* **1933**, 1200.
- (156) REPPE, W., SCHLICHTING, O., AND MEISTER, H.: *Ann.* **560**, 93 (1948).
- (157) ROBINSON, R.: *J. Chem. Soc.* **1938**, 1390.
- (158) RONIGER, H.: Thesis, Eidgenössische Technische Hochschule, Zurich, Switzerland, 1943.
- (159) RUHEMANN, S., AND LEWY, K.: *Ber.* **60**, 2459 (1927).
- (160) RUZICKA, L., *et al.*: *Helv. Chim. Acta* **16**, 268 (1933).
- (161) RUZICKA, L., CAPATO, E., AND HUYSER, H. W.: *Rec. trav. chim.* **47**, 373 (1928).
- (162) RUZICKA, L., AND HAAGEN-SMIT, A. J.: *Helv. Chim. Acta* **14**, 1104 (1931).
- (163) RUZICKA, L., AND VAN MELSON, J. A.: *Helv. Chim. Acta* **14**, 397 (1931).

- (164) RUZICKA, L., AND MEYER, J.: *Helv. Chim. Acta* **4**, 505 (1921).
(165) RUZICKA, L., MEYER, J., AND MINGAZZINI, M.: *Helv. Chim. Acta* **5**, 345 (1922).
(166) RUZICKA, L., PONTALTI, S., AND BALAS, F.: *Helv. Chim. Acta* **6**, 855 (1923).
(167) RUZICKA, L., AND RUDOLPH, E. A.: *Helv. Chim. Acta* **9**, 131 (1926).
(168) RUZICKA, L., AND STOLL, M.: *Helv. Chim. Acta* **5**, 929 (1922).
(169) SABATIER, P., AND MAILHE, A.: *Compt. rend.* **158**, 985 (1914).
(170) SABETAY, S., AND SABETAY, H.: *Compt. rend.* **199**, 313 (1934).
(171) SCHECHTER, M. S., AND HALLER, H. L.: *J. Am. Chem. Soc.* **63**, 3507 (1941).
(172) SCHLÄPFER, P., AND STADLER, O.: *Helv. Chim. Acta* **9**, 185 (1926).
(173) SCHWARZ, R., AND PELUGMACHER, D.: *J. prakt. Chem.* [2] **156**, 205 (1940); **158**, 2 (1941).
(174) SEMMLER, F. W.: *Aetherische Oele*, Vol. III, pp. 260 ff. Veit and Co., Leipzig (1906).
(175) SEMMLER, F. W., AND JAKUBOWICZ, W.: *Ber.* **47**, 2252 (1914).
(176) SHERNDAL, A. E.: *J. Am. Chem. Soc.* **37**, 167, 1537 (1915).
(177) SIMPSON, J. C. E., AND WILLIAMS, N. W.: *J. Chem. Soc.* **1938**, 2040.
(178) SKLAR, A. L.: *J. Chem. Phys.* **5**, 669 (1937).
(179) SÖRENSEN, N. A., AND HOUGEN, F.: *Acta Chem. Scand.* **2**, 447 (1948).
(180) ŠORM, F.: *Collection Czechoslov. Chem. Commun.* **12**, 251 (1947).
(181) ŠORM, F., DOLEŠ, L., KNESSL, O., AND PLIVA, J.: *Collection Czechoslov. Chem. Commun.* **15**, 82 (1950).
(182) ŠORM, F., AND FAJKOŠ, J.: *Collection Czechoslov. Chem. Commun.* **12**, 81 (1947).
(182a) ŠORM, F., AND HEROUT, V.: *Collection Czechoslov. Chem. Commun.* **13**, 177 (1948).
(183) ŠORM, F., AND KNESSL, O.: *Collection Czechoslov. Chem. Commun.* **14**, 201 (1949).
(184) ŠORM, F., ŠORMOVÁ, Z., AND ŠEDIVÝ, L.: *Collection Czechoslov. Chem. Commun.* **12**, 554 (1947).
(185) ŠORM, F., TOMÁŠEK, V., AND VRBA, R.: *Collection Czechoslov. Chem. Commun.* **14**, 343 (1949).
(186) ŠORM, F., VONAŠEK, F., AND HEROUT, V.: *Collection Czechoslov. Chem. Commun.* **14**, 91 (1949).
(187) SPENGLER, H., AND WEISFLOG, G.: *Pharm. Acta Helv.* **22**, 190 (1947).
(188) SPOELSTRA, D. B.: *Rec. trav. chim.* **48**, 372 (1928).
(189) STOBBE, H.: *Ann.* **308**, 67, 123 (1899); **321**, 83 (1902).
(190) SUSZ, B., PFAU, A. ST., AND PLATTNER, PL. A.: *Helv. Chim. Acta* **20**, 471 (1937).
(191) THIELE, J., AND BALHORN, H.: *Ann.* **348**, 1 (1907).
(192) THIELE, J., AND BÜHNER, A.: *Ann.* **347**, 249 (1906).
(193) TREIBS, W.: *Naturwissenschaften* **33**, 371 (1946).
(194) TREIBS, W.: *Angew. Chem.* **59**, 244 (1947).
(195) TREIBS, W.: *Chem. Ber.* **81**, 38 (1948).
(196) TREIBS, W.: *Ann.* **564**, 141 (1949).
(196a) TREIBS, W.: *Ann.* **570**, 165 (1950).
(197) TREIBS, W., AND BARCHET, H. M.: *Ann.* **566**, 89 (1950).
(198) TREIBS, W., AND FROITZHEIM, H.: *Ann.* **564**, 43 (1949).
(199) TROST, F., AND DORO, B.: *Ann chim. applicata* **26**, 126 (1936); *Chem. Zentr.* **1936**, **II**, 2029.
(200) TSCHIRCH, A., AND HOHENADEL, M.: *Arch. Pharm.* **233**, 259 (1895).
(201) UKITA, T.: *J. Pharm. Soc. Japan* **59**, 80 (1939).
(202) VONDERBANK, H.: *Pharmazie* **4**, 198 (1949).
(203) WAGNER-JAUREGG, T., ARNOLD, H., AND HÜTER, F.: *Ber.* **75**, 1293 (1942).
(204) WAGNER-JAUREGG, T., ARNOLD, H., HÜTER, F., AND SCHMIDT, J.: *Ber.* **74**, 1522 (1941).
(205) WAGNER-JAUREGG, T., FRIESS, E., HIPPCHEM, H., AND PRIER, F.: *Ber.* **76**, 1157 (1943).
(206) WAGNER-JAUREGG, T., AND HIPPCHEM, H.: *Ber.* **76**, 694 (1943).
(207) WALLACH, O., AND TUTTLE, F. E.: *Ann.* **279**, 391 (1894).
(208) WHELAND, G. W.: *J. Am. Chem. Soc.* **63**, 2025 (1941).
(209) WHELAND, G. W., AND MANN, D. E.: *J. Chem. Phys.* **17**, 264 (1949).
(210) WIENHAUS, H., AND RADJAHN, T. C.: *J. prakt. Chem.* [2] **147**, 113 (1936).

- (211) WILLSTAEDT, H.: Ber. **68**, 333 (1935).
- (212) WILLSTAEDT, H.: Ber. **69**, 997 (1936).
- (213) WILLSTAEDT, H.: Atti Congr. intern. chim., 10th Congr., Rome, **1938**, Vol. 3, p. 390 (1939); Chem. Abstracts **34**, 3753 (1940).
- (214) WILLSTAEDT, H.: Svensk Kem. Tid. **58**, 23, 81 (1946).
- (215) WILLSTAEDT, H., AND ZETTERBERG, B.: Svensk Kem. Tid. **58**, 306 (1946).
- (216) WILLSTÄTTER, R., AND HEIDELBERGER, M.: Ber. **46**, 519 (1913).
- (217) WOLF, W.: Fette u. Seifen **47**, 122 (1940).
- (218) WOLFF, C.: Pharm. Ztg. No. **82** (1878).
- (219) ZECHMEISTER, L., AND CHOLNOKY, L.: *Die chromatographische Adsorptionsmethode*, Vol. II, p. 27. J. Springer, Vienna (1938).