

# THE SIGNIFICANCE OF ENTROPIES OF TRANSITION IN SALTS, WITH SPECIAL REFERENCE TO NITRATES

D. M. NEWNS AND L. A. K. STAVELEY

*The Inorganic Chemistry Laboratory, Oxford University, Oxford, England*

*Received January 10, 1966*

## CONTENTS

I. Introduction.....	267
II. Some General Observations on Entropies of Transition.....	268
III. Transitions in Monovalent Nitrates.....	270
A. General Survey.....	270
B. Sodium Nitrate.....	270
C. Potassium Nitrate.....	272
D. Silver Nitrate.....	273
E. The Transition Common to Rubidium, Thallium, and Cesium Nitrates.....	274
F. The III $\rightarrow$ II Transition in Thallium Nitrate.....	276
G. The Higher Transitions of Rubidium Nitrate.....	276
IV. References.....	277

## I. INTRODUCTION

For some of the very numerous transitions in inorganic salts, reliable values of the entropy of transition  $\Delta S$  are now available. The most accurate of these have been determined by direct calorimetry. For other transitions, the value of  $\Delta S$  derives from a study (often by Bridgman) of the effect of pressure on the transition temperature. For a few transitions where the change is sluggish and one of the forms can exist in a supercooled or superheated state, appropriate heat of solution measurements have given the necessary heat of transition.

This review is concerned with the interpretation of the values of  $\Delta S$  for transitions in inorganic salts where there are *a priori* reasons for thinking that the disorder gained on passing to the high-temperature form is essentially disorder of orientation of a diatomic or polyatomic ion. We shall first briefly make some general observations, and then consider in more detail the significance of the values of  $\Delta S$  for transitions in monovalent metallic nitrates. This particular group of salts has been selected for detailed consideration for several reasons. In the first place, accurate  $\Delta S$  values for most of the numerous transitions which they display are now available, chiefly as a result of recent calorimetry by Finnish workers. Moreover, there is a considerable amount of information on their crystallographic, optical, electrical, and other properties, which has been reviewed by McLaren (41), who, however, did not introduce entropy considerations into the interpretation of the phase relationships. Furthermore, in spite of the apparent similarity of these salts, there is an interesting diversity in their polymorphism. Of the alkali nitrates, lithium nitrate alone has no thermally detectable transition (although

Rhodes and Ubbelohde (52) observed a slight discontinuity at 170° in the absorption coefficient which they ascribed to a previously undiscovered transition). All other alkali nitrates show at least one transition, and silver and thallium nitrates are also polymorphic. But of these six monovalent nitrates with transitions, no two are structurally identical in all corresponding phases. While this implies that interaction between these ions has a sensitive dependence on the size and perhaps the electronic structure of the cation, the monatomic nature of the cations and the symmetry of the nitrate ion are factors which encourage one to hope that attempts to interpret the entropies of transition will achieve at least some success.

Attempts to understand and quantitatively to account for the entropies of transition in *molecular* solids have already been made, notably by Guthrie and McCullough (24) and by Westrum (72). Guthrie and McCullough sought to estimate the number of possible orientations available to a molecule in the high-temperature disordered form of the crystal by examining the symmetry of the molecule in relation to that of the lattice, and by considering which otherwise possible or likely orientations would be effectively put out of action by the mutual repulsion of atoms in neighboring molecules. It might appear that in trying to explain the  $\Delta S$  values for transitions in salts we are choosing a somewhat easier problem than that presented by the molecular crystal, at least if one of the sets of ions in the lattice is monatomic, for then any one of the diatomic or polyatomic ions might seem to be, as it were, protected from the complication of interference from other identical ions by the intermediate shell of first-neighbor monatomic ions. Undoubtedly for some salts the problem is simplified in this way. But we

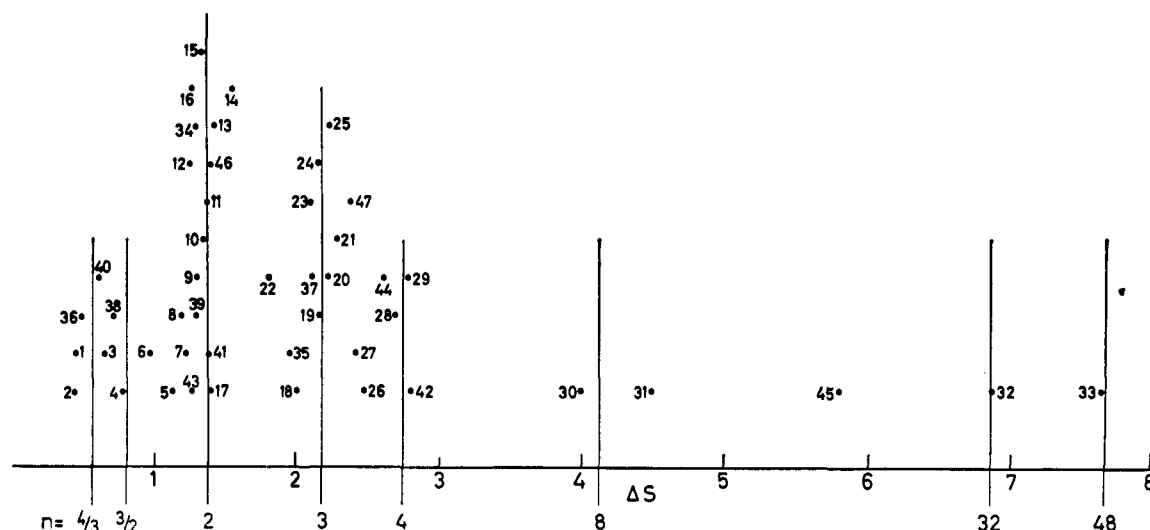

Figure 1.—Values of  $\Delta S$  in cal/mole deg for transitions in salts.  $n$  is the simple fraction or integer for the values of  $\Delta S$  given by the vertical lines, where  $\Delta S = R \ln n$ . The height of the points above the baseline has no significance. In the following key, the Roman numeral I refers to the phase stable at the highest temperatures, and successively higher numerals denote the phases stable at progressively lower temperatures. (1)  $\text{NH}_4\text{NO}_3$ , V  $\rightarrow$  IV, first order (64); (2)  $\text{RbNO}_3$ , II  $\rightarrow$  I, first order (45); (3)  $\text{TlNO}_3$ , III  $\rightarrow$  II, first order (8); (4)  $\text{KBH}_4$ ,  $\lambda$  type ( $\Delta S$  from the heat of transition is 0.70 eu, but there are grounds for believing that further disorder is gained over a considerable temperature range above the  $\lambda$  point and that the total entropy increase associated with the order-disorder transformation may amount to  $R \ln 2$  (23).); (5)  $\text{K}_2\text{SnCl}_6$ ,  $\lambda$  type ( $\Delta S$  may be in error by 0.2 eu (42).); (6) *n*-amylammonium chloride,  $\text{NH}_3\text{C}_6\text{H}_{11}\text{Cl}$ , III  $\rightarrow$  II,  $\lambda$  type (62); (7)  $\text{NaBH}_4$ ,  $\lambda$  type (29); (8)  $\text{NaCN}$ , III  $\rightarrow$  II,  $\lambda$  type (58); (9)  $\text{KCN}$ , III  $\rightarrow$  II,  $\lambda$  type (68); (10)  $\text{NH}_4\text{Cl}$  and  $\text{ND}_4\text{Cl}$ , III  $\rightarrow$  II,  $\lambda$  type ( $\Delta S$  is reported as lying between 1.2 and 1.5 eu, and is plotted here as 1.35 eu (65).); (11)  $\text{NH}_4\text{I}$ , III  $\rightarrow$  II,  $\lambda$  type ( $\Delta S$  is simply reported as agreeing with  $R \ln 2$  (66).); (12)  $\text{NaNO}_3$ ,  $\lambda$  type (43); (13)  $\text{KNO}_3$ , II  $\rightarrow$  III, first order (46); (14)  $\text{RbNO}_3$ , III  $\rightarrow$  II, first order (3); (15)  $\text{NH}_4\text{NO}_3$ , IV  $\rightarrow$  III, first order (64); (16) *n*-amylammonium chloride,  $\text{NH}_3\text{C}_6\text{H}_{11}\text{Cl}$  ( $\lambda$  type transition in a metastable form of the salt (62).); (17)  $(\text{NH}_4)_2\text{SiF}_6$ , hexagonal form,  $\lambda$  type (67); (18)  $\text{KCN}$ , II  $\rightarrow$  I,  $\lambda$  type (68); (19)  $\text{NH}_4\text{Br}$ , II  $\rightarrow$  I, first order (1); (20)  $\text{NH}_4\text{PF}_6$ , II  $\rightarrow$  I,  $\lambda$  type (63); (21) *n*-amylammonium chloride,  $\text{NH}_3\text{C}_6\text{H}_{11}\text{Cl}$ , II  $\rightarrow$  I,  $\lambda$  type (62); (22)  $\text{KNO}_3$ , III  $\rightarrow$  I, first order (45); (23)  $\text{RbNO}_3$ , IV  $\rightarrow$  III, first order (3); (24)  $\text{TlNO}_3$ , II  $\rightarrow$  I, first order (4); (25)  $\text{CsNO}_3$ , II  $\rightarrow$  I, first order (27); (26)  $\text{NH}_4\text{PF}_6$ , III  $\rightarrow$  II,  $\lambda$  type (63); (27)  $\text{RbPF}_6$ ,  $\lambda$  type (63); (28)  $(\text{NH}_4)_2\text{SO}_4 \cdot \text{Al}_2(\text{SO}_4)_3 \cdot 24\text{H}_2\text{O}$ , first order (59); (29)  $(\text{NH}_4)_2\text{SO}_4 \cdot \text{Cr}_2(\text{SO}_4)_3 \cdot 24\text{H}_2\text{O}$ ,  $\lambda$  type (Although it is true that the chromium ion should develop a magnetic entropy of  $R \ln 4$ , it is reported that whether or not this anomaly appears depends on the thermal history of the sample, which is characteristic of a transition involving structural changes rather than a magnetic transition (30).); (30)  $(\text{NH}_4)_2\text{SO}_4$ ,  $\lambda$  type (estimated uncertainty of  $\pm 0.4$  eu in  $\Delta S$  (59)); (31)  $(\text{NH}_4)_2\text{SnBr}_6$ ,  $\lambda$  type (Uncertainty in  $\Delta S$  may be several tenths eu (42).); (32)  $\text{KPF}_6$ , first order (63); (33)  $\text{Ni}(\text{NO}_3)_2 \cdot 6\text{NH}_3$ ,  $\lambda$  type (estimated uncertainty of  $\pm 0.5$  eu in  $\Delta S$  (39)); (34)  $\text{KCNS}$ ,  $\lambda$  type (54); (35)  $(\text{NH}_4)_2\text{CuCl}_4 \cdot 2\text{H}_2\text{O}$ ,  $\lambda$  type (69); (36)  $\text{NH}_4\text{CNS}$ , II  $\rightarrow$  I,  $\lambda$  type (58); (37)  $\text{NH}_4\text{CNS}$ , III  $\rightarrow$  II,  $\lambda$  type (58); (38)  $\text{NH}_4\text{Br}$ , III  $\rightarrow$  II,  $\lambda$  type,  $C_p$  reaching a maximum at 235°K (There is a lower,  $\lambda$ -type transition, with  $C_p$  reaching a maximum at 107.5°K for which the entropy increase is very small ( $\sim 0.27$  eu) (58).); (39)  $\text{SrCa}_2(\text{C}_2\text{H}_5\text{CO}_2)_6$ , III  $\rightarrow$  II,  $\lambda$  type (58); (40)  $\text{SrCa}_2(\text{C}_2\text{H}_5\text{CO}_2)_6$ , II  $\rightarrow$  I,  $\lambda$  type (58); (41)  $\text{RbCN}$ ,  $\lambda$  type (58); (42)  $\text{NaCN}$ , II  $\rightarrow$  I,  $\lambda$  type (58); (43)  $\text{NaNO}_3$ ,  $\lambda$  type (This is the total entropy change in an unusual type of gradual transition in which a first peak in the heat capacity at 163.4° is followed by a second peak at 165.0° (58).); (44)  $\text{CsCN}$ ,  $\lambda$  type (58); (45)  $\text{PbCa}_2(\text{C}_2\text{H}_5\text{CO}_2)_6$ ,  $\lambda$  type (58); (46)  $\text{AgNO}_3$ , first order (27); (47)  $\text{NH}_4\text{Cl}$ , II  $\rightarrow$  I, first order (1).

shall see that it does not seem possible to interpret the  $\Delta S$  values for some transitions in the alkali nitrates without taking account of the restriction which one nitrate ion may place on the orientations available to neighboring nitrate ions, notwithstanding that these are not nearest neighbors. Of course, for a salt such as ammonium nitrate, where both ions are polyatomic, the problem of working out the number of accessible orientations could be just as complicated, if not more so, than for a molecular crystal.

This review covers the relevant literature on the polymorphism of monovalent nitrates up to the end of 1964.

## II. SOME GENERAL OBSERVATIONS ON ENTROPIES OF TRANSITION

Even though the chief contribution to  $\Delta S$  for a particular transition may arise because an increased number of orientations or positions becomes avail-

able to the ions, there will in principle also be an entropy change due to the alteration in the lattice vibrational frequency distribution brought about by the alteration in crystal structure and by the associated volume change. If a salt with diatomic or polyatomic ions passes from a low-temperature form in which these ions have just one orientation each to a form in which each ion has  $n$  energetically equivalent or almost equivalent distinguishable orientations, the entropy gain on this account will be  $R \ln n$ . Due to the change in the vibrational frequency distribution, the actual entropy increase will differ from  $R \ln n$  by an amount which one would much like to be able to calculate reliably. Attempts have been made to estimate this nonconfigurational contribution to the entropy change at a transition from the volume change. Thus, Slater (61) suggested that the quantity  $\Delta S/\Delta V$  for the transition might be taken to be approximately

equal to  $(\partial S/\partial V)_T$  for one of the two phases. This latter quantity can be estimated from the coefficient of expansion  $\alpha$  and the isothermal compressibility  $\kappa$  by virtue of the relation

$$\left(\frac{\partial S}{\partial V}\right)_T = \left(\frac{\partial P}{\partial T}\right)_V = \frac{\alpha}{\kappa}$$

It would seem that this procedure for estimating the nonconfigurational entropy term is not well founded. The obvious transitions on which to test it are those in salts containing only monatomic ions, of which transitions there are unfortunately rather few. The heat of transition from the simple cubic to the face-centered cubic form of cesium chloride (which takes place at atmospheric pressure) has not apparently been determined. There are transitions from a sodium chloride to a cesium chloride structure in potassium and rubidium halides under pressure, for which Bridgman (9, 10) measured the volume change  $\Delta V$  and the pressure coefficient of the transition temperature. More accurate values for the latter quantity have recently been obtained by Pistorius (50, 51) which, combined with Bridgman's  $\Delta V$  values, give the entropies of transition shown in Table I, where they are

TABLE I<sup>a</sup>ENTROPY ( $\Delta S$ ) AND VOLUME CHANGES ( $\Delta V$ ) FOR TRANSITIONS IN POTASSIUM AND RUBIDIUM HALIDES

Salt	$\Delta V$	$\Delta S$	
		Exptl	Calcd
KCl	10.5	0.028	1.76
KBr	10.2	0.050	1.49
KI	8.7	-0.15	1.26
RbCl	14.6	0.45	2.20
RbBr	11.3	0.31	1.67
RbI	10.7	0.30	1.82

<sup>a</sup>  $\Delta S$  is in cal/mole deg, and  $\Delta V$  is the percentage volume increase at the transition, the direction of the transition being from the cesium chloride to the sodium chloride form.  $\Delta V$  is taken from Bridgman's work (9, 10). The experimental values of  $\Delta S$  are derived from these values of  $\Delta V$  and the measurements by Pistorius (50, 51) of the pressure dependence of the transition temperature. The calculated values of  $\Delta S$  are those obtained by the method suggested by Slater (61) (see text).

compared with estimates made on the basis suggested by Slater, using known values of the compressibility (12) and expansion coefficients (25, 53). These estimates are altogether higher than the experimental values, and it is worth noting that the data for potassium iodide show that the denser phase need not necessarily have the smaller entropy. Bridgman (11) found that in fact this was the case in no less than 43% of all the transitions he studied. No greater confidence can be placed in attempts to estimate the nonconfigurational entropy contribution on a free-volume basis, bearing in mind the arbitrary nature of this concept. However, the data of Table I suggest that this contribution may only be a few tenths of an entropy

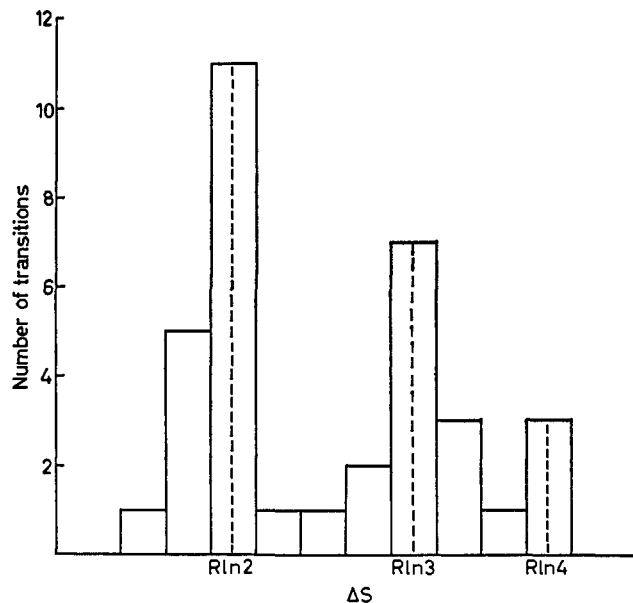

Figure 2.—Distribution of values of entropy of transition  $\Delta S$  for the thirty-five transitions of Figure 1 for which  $\Delta S$  lies between 0.8 and 3 eu. The width of each column is 0.2 eu.

unit. When relatively trivial changes in crystal structure are involved, it could well be less. In any case, by the third law of thermodynamics, it should be less important the lower the temperature. So attempts to account quantitatively for transition entropies on an  $R \ln n$  basis are more likely to succeed at lower rather than higher temperatures, and for transitions involving only minor changes in the mutual arrangement of the anions and cations. There is, however, another, more empirical, reason for believing that the over-all entropy change at many transitions is dominated by a configurational term of the form  $R \ln n$ . In Figure 1 are displayed the experimental values of the entropies of transitions in various salts. This figure embodies all the reliable data we have been able to assemble on transitions for some of which it seems virtually certain and for the rest at least plausible that orientational disorder of one or both ions is involved. (Magnetic transitions and transitions such as those in phosphates and arsenates known to involve randomness in the arrangement of hydrogen bonds have not been included.) The way the experimental entropies group themselves round  $R \ln n$  values of potentially significant  $n$  is striking (Figure 2). Some of the data in Figure 1 refer to gradual transitions, and if the transition is spread over a considerable temperature range (and especially if the compound is rather complex and the total heat capacity large anyway) it is notoriously difficult to make a precise estimate of the extra entropy intake associated with the transition. Some lack of correspondence between the experimental  $\Delta S$  and a "significant"  $R \ln n$  could for gradual transitions such as that in ammonium stannibromide be partly due to uncertainty in the estimate of  $\Delta S$ .

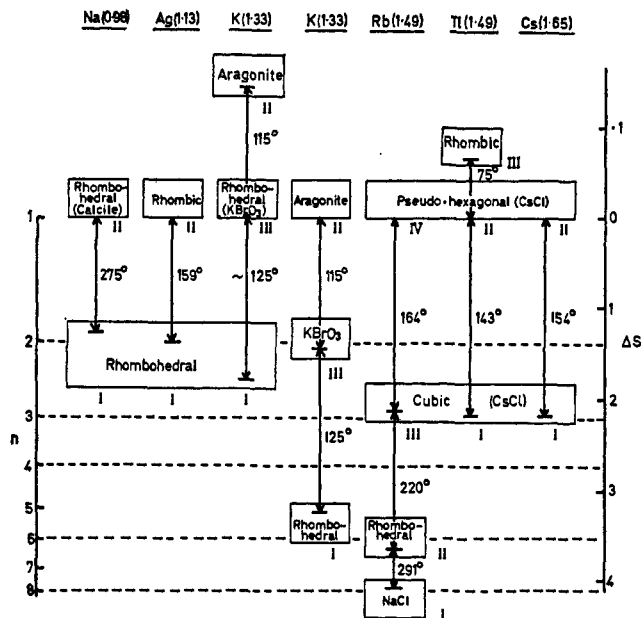

Figure 3.—Showing the entropy and structural relations for the transitions in the nitrates of sodium, silver, potassium, rubidium, thallium, and cesium. The metal ions are arranged horizontally in the order of their ionic radii (given in parentheses, in angstrom units). The vertical distances shown by the arrowed lines represent the experimental values of the entropies of transition. The numbering of the phases is that used in the legend of Figure 1, except that for potassium nitrate, III denotes a metastable phase intermediate between I and II. The scale on the right represents the entropy in cal/mole deg, and that on the left  $n$  in the relation  $\Delta S = R \ln n$ . The zero of  $\Delta S$  is the phase which is considered to have zero configurational entropy. Two possible interpretations are shown for potassium nitrate which are discussed in the text. The temperatures are the transition temperatures in  $^{\circ}\text{C}$ .

It must not, however, be forgotten that occasionally a transition in an inorganic salt may involve a rather profound alteration in the nature of the forces between the particles in the lattice as, for example, in a change from a somewhat covalent to an essentially ionic lattice. This could so alter the vibrational frequency distribution that the corresponding entropy term might change considerably.

### III. TRANSITIONS IN MONOVALENT NITRATES

#### A. GENERAL SURVEY

Some facts about the four polymorphic alkali nitrates and about silver and thallos nitrates are summarized in Figure 3. The lengths of the vertical, arrowed lines are proportional to the entropies of transition. The entropy scale starts from zero for the phase in which the configurational entropy of the salt is considered to be zero, in the sense that each nitrate ion in that phase is believed to have a unique orientation and position in the lattice (apart from the few ions which may be affected by lattice defects). We shall in due course attempt to justify the belief, expressed in Figure 3, that in thallos nitrate this configurational entropy is zero not only in the form stable at the lowest tem-

peratures but probably in the form above this as well. It is also possible that phases II and III of potassium nitrate both have zero configurational entropy, and this is shown as one possibility in Figure 3, but an alternative interpretation is also represented which is discussed in section C. For a salt such as rubidium nitrate with more than one transition the figure shows the cumulative configurational entropy. The numbering of the phases is on the usual convention that I is the phase stable at the highest temperatures. The apparent inversion of phases II and III for potassium nitrate will be explained in section C.

It will be seen that the salts appear to fall into two groups. The three salts with the smallest cations have structures approximately related to a sodium chloride lattice and show transitions for which  $\Delta S$  is near  $R \ln 2$ . The three salts with the largest cations tend to have structures deriving from a cesium chloride lattice and show a transition for which  $\Delta S$  is close to  $R \ln 3$ .

Before considering each individual salt, a general observation may be made on the question of rotation of the nitrate ion. From time to time it has been suggested that such rotation (at least in one degree of freedom, *e.g.*, in the plane of the oxygen atoms) accompanies some of the transitions in these salts. It seems to us that the balance of the evidence rules out free rotations in the literal sense, even in one degree of freedom, in any nitrate in any phase. References to work which bear on this matter for particular salts are given below, but entropy considerations themselves support the statement just made, partly because so many values are close to  $R \ln n$  with  $n$  integral, and partly because these values are not nearly large enough to be ascribed to free rotation. The rotational entropy of an ion rotating freely in three degrees of freedom would be  $\sim 25$  eu (28).

In Table II are collected parameters of the various transitions excluding those of  $R \ln 3$  entropy change. The parameters of the rhombohedral structures are all referred to a unimolecular rhombohedron for convenience. The volume changes given in Tables I, II, and III are taken where possible from Bridgman's work. When Bridgman's values for  $\Delta S$ —derived from his measured values of  $\Delta V$  and the pressure coefficient of the transition temperature—are compared with modern calorimetric values, it appears that the accuracy of the  $\Delta V$  measurements must be about 5%, which is often superior to that of simple dilatometric determinations.

#### B. SODIUM NITRATE

Sodium nitrate has the calcite structure. This can be regarded as derived from the sodium chloride lattice by replacing the anions by nitrate ions lying in planes which are all normal to one of the threefold axes of the

TABLE II<sup>a</sup>  
PARAMETERS OF RHOMBOHEDRAL PHASES IN NITRATES AND ASSOCIATED TRANSITIONS

Substance	Transition	$T_{Tr}$	$\Delta S$	$\Delta V$ , %	Structure of phase	$a$ , A	Axial angle	$T_{meas}$
NaNO <sub>3</sub>	II → I	275 ( $\lambda$ )	1.26 (43)	1.9 (31)	II (73)	4.05	77° 28'	25
NaNO <sub>3</sub>					I (73)	4.15	75° 31'	280
AgNO <sub>3</sub>	II → I	159	1.37 (2)	-1.1 (8)	I (49)	4.13	78° 0'	164
KNO <sub>3</sub>	II → III		1.44 (46)	-1.7 (8)	II (73)	4.46	74°	25
KNO <sub>3</sub>	III → I		1.81 (46)	3.0 (8)	III (6)	4.36	76° 56'	120
KNO <sub>3</sub>	II → I	127	3.23 (46)	1.1 (8)	I (36)	4.49	73° 50'	
RbNO <sub>3</sub>	III → II	220	1.53 (45)	~10 (15)	II (21)	4.77	70° 10'	250
			1.57 (3)					
RbNO <sub>3</sub>	II → I	291	0.42 (45)	~1 (15)	I (13)	NaCl $d = 7.32$		
TlNO <sub>3</sub>	III → II	75	0.7 (8)	0.4 (8)	III (14)	Rhombic		

<sup>a</sup>  $T_{Tr}$  is the transition temperature in °C,  $\Delta S$  the entropy change in cal/mole deg, and  $\Delta V$  the percentage volume increase. The structural parameters are values determined at a temperature  $T_{meas}$ , in °C, and refer to the rhombohedron containing one molecule which is not necessarily the true unit cell.  $a$  is the rhombohedral edge length, and the axial angle is the angle between the edges. Figures for aragonite-like structures are based on the approximation that the local (distorted octahedral) environment of an anion forms part of a rhombohedron. For RbNO<sub>3</sub>-I,  $d$  is the edge length of the unit cell. The reference numbers are given in parentheses.  $R \ln 2 = 1.38$ .

TABLE III<sup>a</sup>  
PARAMETERS FOR TRANSITIONS IN RbNO<sub>3</sub> (IV → III), TlNO<sub>3</sub> (II → I), AND CsNO<sub>3</sub> (II → I)

Substance	$T_{Tr}$	$\Delta S$		$\Delta V$ , %	Cubic		Hexagonal		$T_{meas}$
					$d$ , A	$T_{meas}$	$a$ , A	$c$ , A	
RbNO <sub>3</sub>	164	2.11 (3)	2.15 (45)	2.1 (8)	4.37 (19)	210	10.45 (48)	7.38	25
TlNO <sub>3</sub>	143	2.18 (4)		1.4 (8)	4.31 (19)	170	10.47 (14)	7.53	130
CsNO <sub>3</sub>	154	2.25 (27)	2.10 (44)	1.5 (8)	4.49 (19)	170	10.87 (17)	7.76	25

<sup>a</sup>  $T_{Tr}$  is the transition temperature in °C,  $\Delta S$  the entropy change in cal/mole deg, and  $\Delta V$  the percentage volume increase. The lattice parameters refer to the cubic form stable above the transition temperature and to the hexagonal form stable below it.  $T_{meas}$  is the temperature in °C of the crystal structure determination. The reference numbers are given in parentheses.  $R \ln 3 = 2.18$ .

crystal. Some collapse of the structure along the three-fold axis takes place to accommodate the flat nitrate ion, so that the octahedral environment of the ions becomes hexagonally distorted. The resulting structure has hexagonal symmetry, with the threefold axis as the  $c$  axis, and can be conveniently referred to a unimolecular rhombohedral unit cell, with cations lying at the corners of the rhombohedron. The nitrates of monovalent metals provide a number of structures of this type, with parameters collected in Table II, but whereas the positions of the cations are known, there is sometimes uncertainty about those of the nitrate ions. It is seen from Table II that the axial angle of the rhombohedron is usually between 70 and 75°. This angle is 60° in the sodium chloride structure itself, while an angle of 90° would give the cesium chloride structure, so the rhombohedral lattice can be considered as intermediate between the sodium chloride and cesium chloride types. In the calcite structure itself, the relation between the nitrate ion and the distorted octahedral environment is shown in Figure 4a. It is seen that there are two possible orientations,  $\alpha$  and  $\beta$ , differing by a 60° rotation about the  $c$  axis, and successive 0001 planes in the structure contain alternately  $\alpha$  and  $\beta$  ions, so that the true unit cell of calcite is in fact a two-molecule rhombohedron.

The transition in sodium nitrate is of the  $\lambda$  type (35, 37), and the calorimetric value for the entropy change is 1.26 eu (43). The volume change as esti-

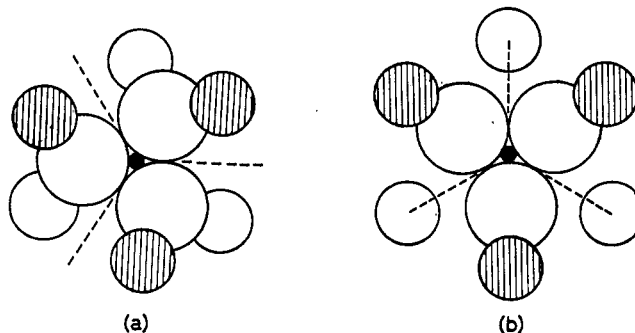

Figure 4.— $c$ -Axis projections of possible hexagonally distorted octahedral environments of a nitrate ion: (a) as in calcite, (b) as in aragonite. Small central circle, nitrogen atom; large circles, oxygen atoms; remaining circles, cations. The shaded cations lie in a plane above the unshaded ones. Dotted lines indicate alternative orientations of the nitrate ion.

mated from the X-ray measurements of Kantola and Vilhonen (31) is about 1.9%. X-Ray diffraction shows a gradual weakening of the oxygen reflections during the transition (38), indicating the onset of orientational disorder of the nitrate ions. The entropy change is close to  $R \ln 2$ , which is certainly simply explained if the high-temperature phase differs only from the ordered phase in that the nitrate ions take up the  $\alpha$  and  $\beta$  positions at random, instead of the layered arrangement. However, we shall see that on the balance of the evidence now available, this picture does not seem to be quite correct. Before stating how

it should be modified, the possibility that the nitrate ions in phase I rotate about their threefold axes should be briefly considered. It is true that several detailed X-ray powder analyses of phase I have been made and that these have consistently preferred a free-rotation model as against a statistically disordered model (7, 38, 70), and also that a low-temperature spectroscopic study (56, 57) gave a value for the barrier to rotation of only 340°K, which is low enough to permit rotation above the  $\lambda$  point. But it seems permissible to doubt the validity of the X-ray conclusion in view of the difficulty of allowing for the large libration about the threefold axes and in the absence of any analysis of a rotation photograph, while with regard to the second piece of evidence, if the coordination number changes, as will be suggested, the barrier may well become higher. More positively, rotation about the threefold axes would require a higher entropy gain, and moreover it is not consistent with Hexter's observation (26) that the vibration-libration spectrum is little changed by the transition, whereas it should disappear with the onset of rotation. Furthermore, an important experiment was performed by Siegel (60), who measured the diffuse background produced when an X-ray beam was directed at a single crystal normal to the  $c$  axis. Certain maxima in the background intensity were observed, due to oxygen reflections, whose existence vindicated the statistical disorder theory, but whose position corresponded instead to the type of configuration shown in Figure 4b, rather than the disorder between the  $\alpha$  and  $\beta$  positions of Figure 4a. The type of coordination shown in Figure 4b is found in aragonite and potassium bromate, and, as will be seen, dominates the polymorphism of potassium nitrate. Whereas in a calcite structure the X of the  $XO_3$  ion is at the midpoint of the distorted octahedron, in an aragonite structure the X atom is displaced along the  $c$  axis from the midpoint, with the anion having an orientation such that looking along the  $c$  axis the oxygen atoms are eclipsed by one set of three cations. There are therefore again two possible positions for the nitrate ion within the unit cell, each associated with its own particular orientation of the nitrate ion, and the full utilization of these two positions would give a configurational entropy of  $R \ln 2$ . It seems probable therefore that this represents the state of affairs in  $NaNO_3$ -I, whereas  $NaNO_3$ -II has a calcite-like structure with the nitrate ions having alternately the  $\alpha$  and  $\beta$  orientations.

### C. POTASSIUM NITRATE

At atmospheric pressure there are only two stable phases of this salt, I and II, with a first-order transition at 127°. In the absence of moisture, phase III can be obtained in a metastable state by cooling phase I, when it appears at about 123° and disappears at about 115°. The triple point, where phase III

first becomes thermodynamically stable, is at a pressure of 30 atm (8, 36). The entropy and volume relations between these phases, together with the parameters of the various structures, are given in Table II. Phase II has the aragonite structure, related to that of nickel arsenide, the cations forming a close-packed hexagonal lattice. The nitrate ions lie in planes normal to the  $c$  axis, being coordinated as shown in Figure 4b. Phase I has a rhombohedral structure, with the nitrate ions orientationally disordered. The X-ray workers (36, 71) are in agreement in finding the nitrate group to be in free rotation about the  $c$  axis, though Tahvonen (70, 71) deduces that there is also movement in the direction of this axis, in both sodium and potassium nitrates. However, the entropy measurements show that rotation is clearly not free.

Phase III is also rhombohedral but is considered to be ordered, with a structure like that of potassium bromate (6, 36), not that of calcite (20). The trigonal ions take up the aragonite coordination (Figure 4b), and now all these ions have the same orientation throughout the structure.

On this evidence it would seem that the III  $\rightarrow$  I transition (but not the II  $\rightarrow$  III transition) involves an order-disorder process, such as that between the two orientations possible with the aragonite coordination. The transition entropy of 1.81 eu is rather larger than the theoretical  $R \ln 2$  ( $=1.37$ ), indicating a considerable vibrational entropy change for which there is unfortunately no independent assessment. Fischmeister (22) has found, however, that in  $KNO_3$ -I there is a notably high coefficient of expansion along the  $c$  axis, larger even than the corresponding quantity for  $NaNO_3$ -I and  $AgNO_3$ -I, and it may be that in this phase the movement of the nitrate ions in this direction (perpendicular to their planes) has become rather facile. Now it is evident that in the aragonite type of coordination, since the nitrate ion must be displaced above or below the midplane, normal to the  $c$  axis, of the distorted octahedron, each cell has a strong dipole. In phase III the nitrate ions lie 6% (6) of the rhombohedron height above the cell center. Since in phase III all the dipoles are oriented parallel, this phase should be ferroelectric, while phase II should be antiferroelectric. In keeping with this, on cooling phase I the dielectric constant reaches a peak of  $\sim 50$  at the transition point, with an abnormally high value persisting in phase III (55).

It is, however, somewhat perplexing that the II  $\rightarrow$  III transition has an entropy change of 1.44 eu, which is more nearly equal to  $R \ln 2$  than that for III  $\rightarrow$  I. It is tempting to suppose that this also is configurational in origin, implying that the structure of phase III as so far described (although in agreement with X-ray and dielectric properties) is to some extent incorrect, since it contains no disorder. To obtain

extra twofold disorder in phases III and I without impairing the possibilities of ferroelectricity, it is necessary to invoke as well in-plane disorder of the nitrate ion. *A priori*, this is not impossible. Figure 5 represents the state of affairs in a rhombohedral cell looking along the  $c$  axis, the nitrogen atom being at the center of the figure and the plane of the nitrate ion parallel to that of the paper. The circles marked  $a$  and  $b$  represent cations. In the calcite structure, the equilibrium position about which the nitrate ion oscillates is  $c$ , each oxygen atom being on the average equidistant from two metal atoms  $a$  and  $b$ . As the nitrate ion rotates in its plane through  $360^\circ$ , it passes through six identical potential energy minima. If it is now displaced along the  $c$  axis, by the time its plane coincides with that passing through one of the sets of three cations (say  $a$ ), its energy at any orientation will undoubtedly now be altogether higher than before; but owing to the strong repulsion between the cations and the oxygen atoms there will presumably be only three positions of minimum potential energy per one complete in-plane rotation, namely the positions of orientation  $d$ . It is therefore possible that for intermediate off-center positions of the nitrate ions the original six minima have not yet disappeared to give only three, but have grouped themselves into three groups of two, the two minima of any one group lying closely and symmetrically about the  $d$  positions. If the two minima are separated by an energy barrier large enough in relation to  $RT$ , then in phase III a configurational entropy of  $R \ln 2$  would be expected. In phase I each of the two possible off-center positions of the nitrate ion could be combined with each of two minima lying a little to each side of position  $d$ , giving a configurational entropy of  $R \ln 4$ . It is worth noting, however, that a third possibility for phase I is that the nitrate ion occupies some more general position of  $C_s$  (mirror plane) symmetry in the rhombohedral environment. Since there are six such positions this would give an expected  $R \ln 6$  which is also quite close to the observed entropy (see Figure 3). Phase I would then be analogous to  $\text{RbNO}_3\text{-II}$  (see section G).

It would be desirable to test these possibilities by actual energy calculations, but unfortunately this cannot be done at all convincingly owing to the uncertainty about the proper way to treat the repulsion between particles, one of which (the oxygen atom in the nitrate ion) is neither in an uncharged state nor in that of a fully charged monatomic ion. If the interpretation giving phase I a configurational entropy of  $R \ln 4$  which has just been briefly and tentatively advanced is felt to be rather *ad hoc*, it is worth remarking that the diversity in the polymorphism of the monovalent nitrates does in fact imply a very sensitive dependence of the energy of different structures on the anion-cation size ratio. Furthermore, an explanation

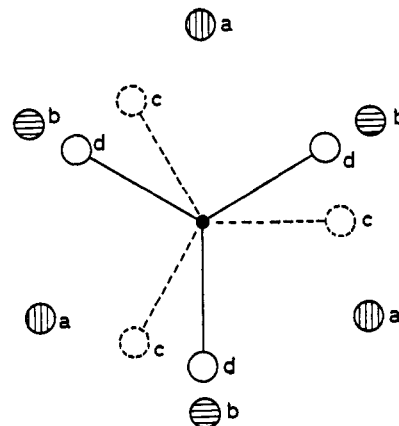

Figure 5.—Projection along the  $c$  axes of a rhombohedral cell to illustrate a possible relation, discussed in the text, between phases III and I of potassium nitrate. Small central circle, nitrogen atom; shaded circles ( $a$  and  $b$ ), cations; open circles ( $c$  or  $d$ ), oxygen atoms. The size of the circles has no significance. In position  $c$ , an oxygen atom is intermediate between an  $a$  and  $b$  cation. In position  $d$ , the oxygen atoms are in the same plane as one set of cations (*e.g.*,  $a$ ).

on the same lines has been advanced to explain why potassium stannichloride has a  $\lambda$  point with an entropy change of about  $R \ln 2$  which is not found for the rubidium salt (42), although the latter is structurally identical with the potassium salt and has a unit cell whose side is only  $\sim 1\%$  longer. However, it is perhaps a weakness of the interpretation set out in the previous paragraph that in the aragonite-like structure of phase II, where the six cations nearest to an anion have almost exactly the same positions as in phase III (see Table II), the nitrate ions have a definite orientation. But if it is argued that only phase I has any configurational entropy (of  $R \ln 2$ ) and that both II and III are ordered, then the 1.44 eu of the II  $\rightarrow$  III transition can only be attributed to an increase in vibrational entropy altogether larger than that which we find it necessary to associate with any other transition in the monovalent nitrates, and this in spite of the close similarity in the relative ionic positions in these two phases to which reference has just been made. A pair of related substances for which entropy data are available (though they are not as precise as could be wished) are the two forms of calcium carbonate, calcite, and aragonite. These are regarded as ordered and appear to differ in entropy by about 0.7 eu/mole (5).

We therefore consider that a firm decision cannot at present be made between the possible interpretations of the configurational entropy relations among the three phases of potassium nitrate, and accordingly the two most likely possibilities are represented in Figure 3.

#### D. SILVER NITRATE

It is well known that the structures of some simple silver salts are radically different from those of the corresponding alkali salts, and it is perhaps not sur-

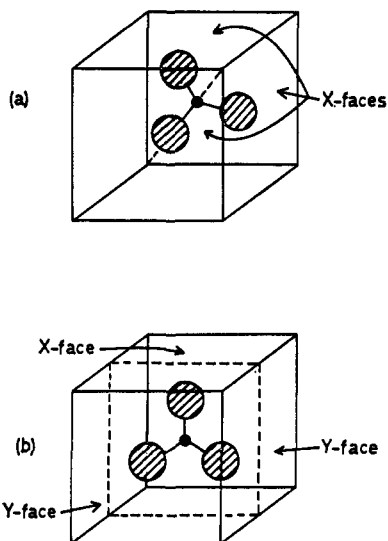

Figure 6.—Two possible positions for a nitrate ion situated in a cube with cations at the corners. In (a), the threefold axis of the nitrate ion coincides with one of the four threefold axes of the environment ( $C_{3v}$  configuration). The faces of the cube marked X are those which the oxygen atoms approach most closely. In (b), the plane of the nitrate ion is parallel to a pair of cube faces ( $C_{2v}$  configuration), and the faces nearest to the oxygen atoms are denoted by X and Y.

prising that  $\text{AgNO}_3\text{-II}$  is not related either to calcite or aragonite, but has a complicated structure which has only been partly resolved (47). Its conversion to phase I takes place in a first-order phase change with a volume contraction of about 1% (8) and an entropy change of 1.37 eu (2)—very close to  $R \ln 2$ . Phase I is rhombohedral (49) (see Table II), but a detailed X-ray analysis is not available and would indeed be difficult because of the large diffracting power of silver.  $\text{AgNO}_3\text{-I}$  forms mixed crystals with  $\text{NaNO}_3$  (8). This is, unfortunately, the only evidence available, but there seems to be no reason to doubt that  $\text{AgNO}_3\text{-I}$  is similar to the other disordered phases we have just considered.

A metastable phase  $\text{AgNO}_3\text{-III}$  of rhombohedral structure is reported to be formed on cooling  $\text{AgNO}_3\text{-I}$  (40). It would be interesting if this proved to be isomorphous with  $\text{KNO}_3\text{-III}$ , but unfortunately dielectric studies of the  $\text{I} \leftrightarrow \text{III}$  transition appear to be inhibited by the high conductivity.

#### E. THE TRANSITION COMMON TO RUBIDIUM, THALLIUM, AND CESIUM NITRATES

Although the nitrates of these metals by no means behave identically as regards their transitions, it is seen from Figure 3 that they do have, rather as the three nitrates already considered, one transition in common, of configurational entropy  $R \ln 3$ . In this case, however, the similarities are much more marked. All three phases  $\text{CsNO}_3\text{-III}$ ,  $\text{TlNO}_3\text{-II}$ , and  $\text{RbNO}_3\text{-IV}$  have the same pseudohexagonal structure below the transition, and all go over to similar cubic phases

above it. In Table III are shown  $\Delta S$  and  $\Delta V$  for the transitions, together with X-ray crystallographic data for the relevant phases; if in addition the transition temperatures are taken into account, the remarkable similarity will be evident. This was first pointed out by Bridgman (8), on the basis of phase diagrams, before more detailed information became available.

The true symmetry of the pseudohexagonal structure is orthorhombic (18, 48), but the departure from hexagonal symmetry is extremely slight, and the structure has been analyzed on the basis of the latter. In the cubic structure the cations lie on a simple cubic lattice, and this is retained in the pseudohexagonal structure, with only a slight rhombohedral distortion of the order of 1%. Thus both structures are related to the CsCl type, but the nitrate ions do not themselves necessarily form a simple cubic lattice. Evidently because of the slight change in lattice dimensions caused by the transition, a single crystal of the pseudohexagonal form can be converted to the cubic form without shattering (18, 41). The reverse process usually results in the formation of a pseudohexagonal crystal containing domains of all possible  $c$ -axis orientations (41).

The values for  $\Delta S$  shown in Table III are recent calorimetric data, and they are quoted as accurate to 2%.  $\Delta S$  is remarkably near to  $R \ln 3$  ( $=2.19$ ). Since, owing to the close relation between the phases, there are good grounds for believing that the vibrational entropy is virtually unaltered at the transition, it is difficult to conclude otherwise than that this difference is genuinely one of configurational entropy. The older suggestions of free rotation of the nitrate ions in the cubic phase can be ruled out on the basis of these entropy measurements, since completely free rotation would mean an entropy contribution of some 25 eu (28). Ferroni, Sabatini, and Orioli (16) concluded that free rotation of the nitrate ions in  $\text{CsNO}_3\text{-I}$  is impossible on spatial grounds. It can be assumed that the configurational entropy of the pseudohexagonal phases is zero, as we have indicated in Figure 3. Although there is no direct experimental proof of this, any other assumption would lead to much greater difficulties in the interpretation of the entropy changes, particularly with  $\text{RbNO}_3\text{-II}$  and  $\text{-I}$  (see section IIIG).

A configurational entropy of  $R \ln 3$  for the cubic phase is unexpectedly low, since the high symmetry of the crystal relative to that of the nitrate ion would always generate more than three, in fact at least eight, equivalent configurations. It is clear in general that interactions between neighboring nitrate groups must be lowering the total number of configurations of the system. The environment of the nitrate ion in both phases consists of eight cations at the corners of a cube. As can be seen by using a model, only two types of configuration are likely in this environment. These



are of  $C_{3v}$  and  $C_{2v}$  symmetry, and are shown in Figures 6a and 6b, respectively. There are eight equivalent orientations of  $C_{3v}$ , and twelve of  $C_{2v}$  type.

Although the X-ray crystallographic evidence is incomplete, a determination of at least the cubic structure is available. On the basis of powder photographs of  $RbNO_3$ -III and  $CsNO_3$ -I, Korhonen (33, 34) found a space group  $T_h^6$  (Pa 3), with eight molecules per unit cell. The structure put forward by him is remarkable in that there is no suggestion of disorder, but the degree of refinement has been described elsewhere (32) as "very good." In this structure the  $NO_3$  group adopts effectively the  $C_{3v}$  configuration in each cube, although the true site symmetry is actually lower than this, being  $C_3$ . Three different X-ray investigations of the pseudo-hexagonal structure have been made (17, 18, 48), and the authors are in agreement in finding a space group of  $C_{3v}^2$  (P 31m), with nine molecules per unit cell, though it has proved impossible to locate the nitrate ions exactly. However, it can be seen that the  $C_{2v}$  configuration for the nitrate ions is incompatible with this information, and indeed it can be deduced that the configuration  $C_{3v}$  is the only one possible. Although, using only the X-ray information, eight distinct structures can be formulated for the pseudo-hexagonal phase with the  $C_{3v}$  configuration, it is possible with reasonable certainty to pick out the one of lowest energy. From Figure 6a it is seen that in the  $C_{3v}$  configuration oxygen atoms protrude markedly into three of the cube faces (which have a corner in common) leaving the other three unhindered, and it can be shown from a model, or by simple calculation, that the sharing in common of two hindered faces by adjacent cubes in the structure would involve close O-O approaches of approximately 1.6-2 Å, compared with  $\sim 3.5$  Å for the nonbonded oxygen diameter. Hence contacts between hindered cube faces can be safely ruled out, and in agreement with this none occur in the structure put forward by Korhonen for the cubic phase. This additional restriction leaves only one possible structure for the pseudo-hexagonal phase, the same one in fact as was suggested by Pauling and Sherman (48) in 1933, but for our purposes the details of this structure are not very important.

In general the configurational entropy of an assembly of cubes containing nitrate ions in the  $C_{3v}$  configuration, with  $R \ln 8$  without the above restriction, drops to zero if contact between hindered faces is forbidden. This can be seen as follows. If we consider any cube in the structure, it can be considered as belonging to three columns of cubes extending along the directions of the three cubic axes to the surface of the crystal. If we label the three sterically hindered faces of the cube as black, and the other three as white, then the restriction of the O-O distance implies that

every cube must have only one black face in contact with it along any axis, so that each column can have only two configurations, neglecting surface effects. Since the whole structure can be considered as made up of such columns, whose number is equal to one-half the surface area  $A$ , then the total number of configurations is  $\Omega = (2^3)^{A/2}$ , neglecting second-order surface effects, so that the configurational entropy of a large assembly is clearly zero. There are of course still an infinite number of possible structures, of which the Korhonen and Pauling and Sherman structures are examples. Evidently the simplest is that with only one molecule per unit cell, analogous to that of  $KNO_3$ -III. However, this appears to be unfavorable when the rhombohedron becomes a cube.

It is therefore necessary to reconcile the crystallographic evidence, which indicates two ordered structures which are different arrangements of the  $C_{3v}$  configuration, and the orientational disorder strongly favored by the entropy measurements. We are led to suggest that the equilibrium position of the nitrate ion is in fact not exactly on the threefold axis of its environment in the cubic structure, but in one of three unsymmetrical positions slightly off the axis, and obtained by a small displacement roughly in the direction of one of the N-O bonds. These three positions are equivalent, on account of the threefold axis, and, provided they are separated by a large enough energy barrier, this clearly gives an entropy of  $R \ln 3$ . The X-ray results would be little affected by such a state of affairs, the disorder merely appearing as an enlarged thermal factor, the magnitude of which would depend on the size of the distortion. The off-center movement would depend on a fine balance of attractive and repulsive forces, and for this reason it is extremely difficult to verify by calculation. A similar situation is well known in the ferroelectric perovskites, but the two cases are not closely comparable.

This seemingly somewhat *ad hoc* explanation of the entropies can moreover in principle account for the true orthorhombic symmetry of the pseudo-hexagonal phases. Some reduction of the  $C_{3v}^2$  symmetry must take place below the transition on account of the complete ordering of the  $NO_3$  groups, provided the tendency for threefold distortion still remains in the low-temperature structure. In fact two-thirds of the anions are reduced to  $C_s$  symmetry, which could remove the possibility of disorder, but the remaining third lie on threefold axes of the  $C_{3v}^2$  space group, and their ordering must involve a further degradation of the symmetry, though the effect, as observed, would be extremely slight. Presumably quadrupole-quadrupole interactions are involved, although the range is rather long, since only the second nearest-neighbor nitrate ions are similarly situated on threefold axes.

Although not in agreement with the X-ray results, it is worth considering the other type of configuration mentioned above, the  $C_{2v}$  configuration of Figure 6b. In this case there are 12 possible orientations, since there are four possible orientations of the  $\text{NO}_3$  ion in its plane, and three alignments of the plane, normal to the three cubic axis. Now it can be seen that the most sterically hindered face of the cube is that shown as X in Figure 6b. However, if contacts between such faces are forbidden in the structure, there is only a reduction in the number of configurations from  $12^N$  to approximately  $11^N$ . It is certainly more realistic to suppose that all three faces, one X and two Y (see Figure 6b), are regarded as "black," but this problem differs from that considered previously in that the three black faces of the cube do not have a corner in common. Now, in a large assembly of cubes where surface effects can be neglected, the number of configurations is given by

$$\Omega_b = (12/8)^N \Omega_a = (3/2)^N$$

where  $\Omega_a$  is the number of configurations in the case of the  $C_{3v}$  configuration considered previously, which is unity for our purposes. This would give an entropy of  $R \ln 3$  if the  $C_{2v}$  position were split up into two positions lying on either side of the midplane of the cube, but this gains nothing in credibility over our previous explanation, while contradicting the structural evidence. We have not been able to find any other set of restrictive conditions, physically realizable or not, which gives exactly, or even approximately,  $R \ln 3$ .

A three-way splitting of the  $C_{3v}$  configuration seems therefore the only tenable hypothesis consistent with the experimental results.

#### F. THE III $\rightarrow$ II TRANSITION IN THALLIUM NITRATE

Unlike the pseudohexagonal forms of  $\text{RbNO}_3$  and  $\text{CsNO}_3$ , this form of  $\text{TlNO}_3$  is not stable at room temperature, but goes over to an orthorhombic form below  $75^\circ$ . According to Bridgman,  $\Delta S$  for this transition is 0.66 eu, and  $\Delta V$  in the direction III  $\rightarrow$  II is 0.4%, no other values for  $\Delta S$  being available (8). A considerable amount of work has been done on the structure of phase III (41), but we shall not discuss this here as it seems unlikely that the III  $\rightarrow$  II transition involves orientational disorder. The assumption of such disorder would destroy the analogy indicated by other evidence between the I  $\leftrightarrow$  II transition in  $\text{TlNO}_3$  and transitions in  $\text{RbNO}_3$  and  $\text{CsNO}_3$ .

#### G. THE HIGHER TRANSITIONS OF RUBIDIUM NITRATE

At  $220^\circ$  the cubic (CsCl) form of  $\text{RbNO}_3$  undergoes a further transition (see Figure 3) of  $\Delta S = 1.57$  (3) or 1.53 eu (45), these being recent calorimetric results. The volume change, obtained dilatometrically, is 10.0% (15). If this entropy is regarded as entirely

configurational, then the total entropy of phase II will be  $2.11 + 1.55 = 3.66$  eu, which is close to  $R \ln 6$  ( $=3.56$ ). This transition is accompanied by severe warping and cracking of the crystal (13).

The phase  $\text{RbNO}_3$ -II goes over at  $291^\circ$  to yet another phase I, which is cubic with the NaCl structure (13). The calorimetric value for the entropy change is 0.42 eu (45), and there is a further increase in volume of 1% (measured dilatometrically) (15). Again treating the entropy as configurational, the total entropy of phase I is  $0.42 + 3.66 = 4.08$ , which is very nearly  $R \ln 8$  ( $=4.13$ ). This last transition is not associated with crystal shattering (13).

Finbak, Hassel, and Strømme (21) found that phase II was rhombohedral (see Table II), but Brown and McLaren (13) prefer a tetragonal structure which preserves almost unchanged the dimensions of the CsCl structures of phases III and IV. However, the latter structure is not in accordance with the large volume change in the III-II transition, when a change from the CsCl to NaCl types of structure is clearly taking place, and the small volume change in the II-I transition. Calculation of the specific volume of the rhombohedral and cubic phases from Brown and McLaren's X-ray parameters confirms this, since it appears that phase I and a rhombohedral phase II should have almost the same specific volume, as observed. This conclusion is also consistent with the observed crystal shattering at the III-II transition but its absence in the II-I transition.

Without making improbable assumptions as to the vibrational entropy, the high entropy of phase II precludes identification with the disordered phases I of the nitrates of smaller cations, even if we allow a configurational entropy of  $R \ln 4$  to  $\text{KNO}_3$ -I. This is not surprising, since on account of their large size the rubidium cations might be expected to be unsuited to the rhombohedral structure, as is shown in the latter's conversion to the cubic NaCl structure, unique in the series. The entropy of  $R \ln 6$  can be explained if it is supposed that the ions do not lie exactly on the three-fold axis of the distorted octahedra, but in off-center positions which may not differ much from the true aragonite-type positions. In this way each of the two possible configurations is split into three by the action of the three-fold axis, giving six orientations in all.

In the NaCl phase I the strain which brought this off-center movement of the nitrate ion is apparently relieved. A nitrate ion is now surrounded octahedrally by six rubidium ions. Four threefold axes pass through the nitrogen atom, and the plane of the anion is at right angles to one of these axes. It is not clear whether the nitrate ion has the calcite (Figure 4a) or aragonite (Figure 4b) type of coordination, but in either event for any one axis there are two possible orientations making eight possible orientations in all,

in agreement with the total configurational entropy of  $R \ln 8$ .

These changes are similar to the familiar conversion of CsCl itself to the NaCl structure at  $460^\circ$ , with a volume change of  $\sim 10\%$ . Rubidium nitrate evidently shows this behavior because the cation radius is intermediate between those of cesium and potassium. Thallium, which is sometimes given a slightly smaller ionic radius than rubidium, might be expected to behave similarly, but this clearly shows the limits of the ionic radius concept when extended to comparisons between A and B group metals. The series of transitions III  $\rightarrow$  II  $\rightarrow$  I in rubidium nitrate can be considered as a progressive conversion from the CsCl to NaCl structures, in that the rhombohedral angle changes from  $90^\circ \rightarrow 70^\circ \rightarrow 60^\circ$ . On the other hand, nearly all the volume change occurs in the III  $\rightarrow$  II transition.

ACKNOWLEDGMENT.—We are grateful to Mr. J. T. S. Andrews for assistance in the early stages of the preparation of this review, to Dr. A. W. Ingleton for helpful discussions on relevant mathematical problems, and to Professor Syuzo Seki for allowing us to use his unpublished results.

#### IV. REFERENCES

- (1) Arell, A., *Ann. Acad. Sci. Fennicae, Ser. A VI*, No. 57 (1960).
- (2) Arell, A., *Ann. Acad. Sci. Fennicae, Ser. A VI*, No. 100, 3 (1962).
- (3) Arell, A., and Varteva, M., *Ann. Acad. Sci. Fennicae, Ser. A VI*, No. 88 (1961).
- (4) Arell, A., and Varteva, M., *Ann. Acad. Sci. Fennicae, Ser. A VI*, No. 98 (1962).
- (5) Bäckström, H. L. J., *J. Am. Chem. Soc.*, **47**, 2432 (1925).
- (6) Barth, T. F. W., *Z. Physik. Chem.*, **B43**, 448 (1939).
- (7) Bijvoet, J. M., and Ketelaar, J. A. A., *J. Am. Chem. Soc.*, **54**, 625 (1932).
- (8) Bridgman, P. W., *Proc. Am. Acad. Arts Sci.*, **51**, 603 (1915).
- (9) Bridgman, P. W., *Z. Krist.*, **67**, 363 (1928).
- (10) Bridgman, P. W., *Phys. Rev.*, **48**, 904 (1935).
- (11) Bridgman, P. W., *Proc. Am. Acad. Arts Sci.*, **72**, 42 (1937).
- (12) Bridgman, P. W., *Proc. Am. Acad. Arts Sci.*, **74**, 21 (1940).
- (13) Brown, R. N., and McLaren, A. C., *Acta Cryst.*, **15**, 974 (1962).
- (14) Brown, R. N., and McLaren, A. C., *Acta Cryst.*, **15**, 977 (1962).
- (15) Cleaver, B., Rhodes, E., and Ubbelohde, A. R., *Proc. Roy. Soc. (London)*, **A276**, 453 (1963).
- (16) Ferroni, E., Sabatini, A., and Orioli, P., *Ric. Sci.*, **27**, 1557 (1957).
- (17) Ferroni, E., Sabatini, A., and Orioli, P., *Gazz. Chim. Ital.*, **87**, 630 (1957).
- (18) Finbak, C., and Hassel, O., *J. Chem. Phys.*, **5**, 460 (1937).
- (19) Finbak, C., and Hassel, O., *Z. Physik. Chem.*, **B35**, 25 (1937).
- (20) Finbak, C., and Hassel, O., *Z. Physik. Chem.*, **B37**, 75 (1937).
- (21) Finbak, C., Hassel, O., and Strømme, L. C., *Z. Physik. Chem.*, **B37**, 468 (1937).
- (22) Fischmeister, H. F., *J. Inorg. Nucl. Chem.*, **3**, 182 (1956).
- (23) Furukawa, G. T., Reilly, M. L., and Piccirelli, J. H., *J. Res. Natl. Bur. Std.*, **68A**, 651 (1964).
- (24) Guthrie, G. B., and McCullough, J. P., *J. Phys. Chem. Solids*, **18**, 53 (1961).
- (25) Henglein, F. A., *Z. Electrochem.*, **31**, 425 (1925).
- (26) Hexter, R. M., *Spectrochim. Acta*, **10**, 291 (1958).
- (27) Hovi, V., Arell, A., and Varteva, M., *Ann. Acad. Sci. Fennicae, Ser. A VI*, No. 39 (1959).
- (28) Janz, G. J., and James, D. W., *Electrochim. Acta*, **7**, 427 (1962).
- (29) Johnston, H. L., and Hallett, N. C., *J. Am. Chem. Soc.*, **75**, 1467 (1953).
- (30) Johnston, H. L., Hu, J.-H., and Horton, W. S., *J. Am. Chem. Soc.*, **75**, 3922 (1953).
- (31) Kantola, M., and Vilhonen, E., *Ann. Acad. Sci. Fennicae, Ser. A VI*, **54**, 1 (1960).
- (32) Korhonen, U., *Structure Reports*, **15**, 277 (1951).
- (33) Korhonen, U., *Ann. Acad. Sci. Fennicae, Ser. A I*, No. 102 (1951).
- (34) Korhonen, U., *Ann. Acad. Sci. Fennicae, Ser. A I*, No. 150 (1953).
- (35) Kracek, F. C., *J. Am. Chem. Soc.*, **53**, 2609 (1931).
- (36) Kracek, F. C., Barth, T. F. W., and Ksanda, C. J., *Phys. Rev.*, **40**, 1034 (1932).
- (37) Kracek, F. C., and Posnjak, E., *J. Am. Chem. Soc.*, **53**, 1183 (1931).
- (38) Kracek, F. C., Posnjak, E., and Hendricks, S. B., *J. Am. Chem. Soc.*, **53**, 3339 (1931).
- (39) Long, E. A., and Toettcher, F. C., *J. Chem. Phys.*, **8**, 504 (1940).
- (40) Mazieres, C., and Hoff, J. van't, *Compt. Rend.*, **256**, 2620 (1963).
- (41) McLaren, A. C., *Rev. Pure Appl. Chem.*, **12**, 54 (1962).
- (42) Morfee, R. G. S., Staveley, L. A. K., Walters, S. T., and Wigley, D. L., *J. Phys. Chem. Solids*, **13**, 132 (1960).
- (43) Mustajoki, A., *Ann. Acad. Sci. Fennicae, Ser. A VI*, No. 5 (1957).
- (44) Mustajoki, A., *Ann. Acad. Sci. Fennicae, Ser. A VI*, No. 7 (1957).
- (45) Mustajoki, A., *Ann. Acad. Sci. Fennicae, Ser. A VI*, No. 9, 3 (1958).
- (46) Mustajoki, A., *Ann. Acad. Sci. Fennicae, Ser. A VI*, No. 99 (1962).
- (47) Niggli, A., *Z. Krist.*, **111**, 269 (1959).
- (48) Pauling, L., and Sherman, J., *Z. Krist.*, **84**, 213 (1933).
- (49) Pistorius, C. W. F. T., *Z. Krist.*, **115**, 291 (1961).
- (50) Pistorius, C. W. F. T., *J. Phys. Chem. Solids*, **25**, 1477 (1964).
- (51) Pistorius, C. W. F. T., *J. Phys. Chem. Solids*, **26**, 1003 (1965).
- (52) Rhodes, E., and Ubbelohde, A. R., *Proc. Roy. Soc. (London)*, **A251**, 156 (1959).
- (53) Rubin, T., Johnston, H. L., and Altmann, H. W., *J. Phys. Chem.*, **66**, 948 (1962).
- (54) Sakiyama, M., Suga, H., and Seki, S., *Bull. Chem. Soc. Japan*, **38**, 1007 (1965).
- (55) Sawada, S., Nomura, S., and Asao, Y., *J. Phys. Soc. Japan*, **16**, 2486 (1961).
- (56) Schroeder, R. A., Weir, C. E., and Lippincott, E. R., *J. Chem. Phys.*, **36**, 2803 (1962).
- (57) Schroeder, R. A., Weir, C. E., and Lippincott, E. R., *J. Res. Natl. Bur. Std.*, **66A**, 407 (1962).
- (58) Seki, S., private communication.
- (59) Shomate, C. H., *J. Am. Chem. Soc.*, **67**, 1096 (1945).
- (60) Siegel, L. A., *J. Chem. Phys.*, **17**, 1146 (1949).
- (61) Slater, J. C., "Introduction to Chemical Physics," McGraw-Hill Book Co., Inc., New York, N. Y., 1939, p 261.
- (62) Southard, J. C., Milner, R. T., and Hendricks, S. B., *J. Chem. Phys.*, **1**, 95 (1933).

- (63) Staveley, L. A., K., Grey, N. R., and Layzell, J. M. T., *Z. Naturforsch.*, **18a**, 148 (1963).
- (64) Stephenson, C. C., Bentz, D. R., and Stevenson, D. A., *J. Am. Chem. Soc.*, **77**, 2161 (1955).
- (65) Stephenson, C. C., Blue, R. W., and Stout, J. W., *J. Chem. Phys.*, **20**, 1046 (1952).
- (66) Stephenson, C. C., Landers, L. A., and Cole, A. G., *J. Chem. Phys.*, **20**, 1044 (1952).
- (67) Stephenson, C. C., Wulff, C. A., and Lundell, O. R., *J. Chem. Phys.*, **40**, 967 (1964).
- (68) Suga, H., Matsuo, T., and Seki, S., *Bull. Chem. Soc. Japan*, **38**, 1115 (1965).
- (69) Suga, H., Sorai, M., Yamanaka, T., and Seki, S., *Bull. Chem. Soc. Japan*, **38**, 1007 (1965).
- (70) Tahvonen, P. E., *Ann. Acad. Sci. Fennicae, Ser. A I*, No. **43** (1947).
- (71) Tahvonen, P. E., *Ann. Acad. Sci. Fennicae, Ser. A I*, No. **44** (1947).
- (72) Westrum, E. F., *Pure Appl. Chem.*, **2**, 241 (1961).
- (73) Wyckoff, R. W. G., "Crystal Structures," Vol. II, Interscience, New York, N. Y., 1948, Section VII.