

LASER-RAMAN SPECTROSCOPY

P. J. HENDRA AND P. M. STRATTON

Department of Chemistry, The University, Southampton SO9 5NH, England

Received June 21, 1968

Contents

I. Introduction	325
A. Historical	325
B. Rotational Spectra	326
C. Vibrational Spectra	326
D. Intensity Measurements	327
II. Experimental	327
A. Introduction	327
B. The Components of a Laser-Raman Spectrometer	327
C. Commercially Available Instruments	329
D. Instrumental Developments	329
III. Raman Spectra of Gases	331
A. Introduction	331
B. Rotational Spectra	331
C. Vibrational and Vibration-Rotational Spectra	332
D. Conclusion	332
IV. Raman Spectra of Inorganic Compounds	332
A. Introduction	332
B. Colored Symmetric Systems	332
C. Compounds of Lower Symmetry	334
D. Photosensitive Compounds	335
E. Miscellaneous Examples	335
F. Conclusion	335
V. Raman Spectra of Organic Compounds	336
A. Low Molecular Weight Compounds	336
B. Polymers	337
C. Charge-Transfer Complexes	337
VI. Raman Spectra of Single Crystals	338
A. Introduction	338
B. Interpretation of the Spectrum of $(\text{NH}_4)_2\text{PtCl}_4$	339
C. Applications	339
VII. Miscellaneous Effects	342
A. Adsorbed Species	342
B. Intensities of Raman Lines	342
C. Nonlinear Effects	343
D. Electronic Raman Spectra	344
VIII. Conclusion	344

I. Introduction

A. HISTORICAL

This article is concerned with the renaissance which has occurred in Raman spectroscopy as a direct result of the application of continuous lasers as sources. We include work published up until February 1968.

Raman spectroscopy is a light-scattering process which may be *illustrated* as follows. If a medium, whose molecular energy is divided between molecules in the ground state (E_0) and in an excited state (E_1), is illuminated with monochromatic radiation of frequency ν_0 when $\nu_0 > [(E_1 - E_0)/h]$, then examination of the scattered radiation will show that it contains radiation of that frequency (Rayleigh scattering), plus other of frequencies $\nu_0 \pm [(E_1 - E_0)/h]$ (Raman scattering). Typically, the intensity of this latter effect is $\sim 10^{-5}$ of the former which is in turn $\sim 10^{-8}$ of the intensity of the source. The intensity of the scattered radiation is dependent upon the sense of polarization of the incident beam and the direction of view. Investigation of this dependence enables the symmetry of the mode causing the effect to be determined in many cases. An excellent introduction to the theory of the Raman effect by Woodward is to be found in ref 1, while books by Brandmüller² and Colthup, Daly, and Wiberley³ may be of value.

Prior to the development of high-speed infrared detectors, the principal method of study of the vibrational characteristics of a molecular system was the use of the Raman effect. Thus, if one consults Kohlrausch's text,⁴ one sees that a very large number of compounds had been examined before the last World War and that the technique originally discovered in 1928 had already made a great contribution to our knowledge of molecular vibrations. Herzberg's books of 1939⁵ and 1945⁶ similarly lay due emphasis on the importance of Raman spectroscopy both in this field and in the study of rotations.

Since the advent of convenient (high-speed, double-beam) infrared spectrometers, Raman spectroscopy has tended to fall into the doldrums. The reasons for this are experimental. Since the effect is a form of light scattering and the source (usually of the mercury discharge type) operates in the visible, the experimental limitations on the sample are stricter than theory would suggest. The sample must be nonturbid of high transmission near the exciting line, and nonfluorescent. A

(1) L. A. Woodward, "Raman Spectroscopy," H. A. Szymanski, Ed., Plenum Press, New York, N. Y., 1967, p 1.

(2) J. Brandmüller, "Einführung in die Ramanspektroskopie," Dr. Dietrich Steinhopff Verlag, Darmstadt, 1962.

(3) N. B. Colthup, L. H. Daly, and S. E. Wiberley, "Introduction to Infrared and Raman Spectroscopy," Academic Press, New York, N. Y., 1964.

(4) K. W. F. Kohlrausch, "Ramanspektren," Akademische Verlagsgesellschaft Becker and Erler Kom.-Ges., Leipzig, 1943.

(5) G. Herzberg, "Spectra of Diatomic Molecules," D. Van Nostrand Co., Inc., New York, N. Y., 1939.

(6) G. Herzberg, "Infrared and Raman Spectra of Polyatomic Molecules," D. Van Nostrand Co., Inc., New York, N. Y., 1945.

sample which is photosensitive is obviously also precluded. Clearly, these limitations weaken Raman spectroscopy as an analytical tool of commercial or development value in comparison with infrared techniques.

Attempts have been made in the past 20 years to avoid some of these difficulties; thus Stammreich⁷⁻¹⁶ and Woodward¹⁷⁻²⁰ in a series of papers investigated the vibrational spectra of deeply colored species using red or near-infrared sources. Their successes include solutions and liquids of such species as chromyl chloride, chloroplatinic acid, and potassium dichromate, but the technique was difficult and most time and patience consuming.

The use of double monochromators, to improve the discrimination between weak and strong emissions of close proximity, was successfully exploited by the Cary Instrument Co.,²¹ and thus colorless, white, and even pale colored powder and crystallites could be examined using conventional mercury discharge sources.

The high-resolution work of Welsh and Stoicheff on the Raman spectra of gases was a great achievement when the experimental problem of low scattering intensity is considered. This field has been reviewed thoroughly.^{22, 23}

During the past few years, chemists have applied laser sources (predominantly the helium-neon continuous wave device) to Raman spectroscopy. It is now quite apparent that most of the limitations as to sample, which once applied, have vanished. In fact, as a broad generalization, a Raman spectrum can be recorded as easily as an infrared one.

Three reviews on the subject have appeared to date. The first two by Brandmüller²⁴ and Zulov, *et al.*,²⁵ deal conclusively with the results of primary interest to physicists while the third, by Köningstein,²⁶ was written sufficiently long ago that it does not refer to the work published since 1965. None of these articles refer to the importance of the effect to chemists, but they do cover very adequately the development of the technique since the first experiments by Porto²⁷ and others. It is now relevant to consider the background to some of the fields in which Raman spectroscopy has provided information.

(7) H. Stammreich, *Phys. Rev.*, **78**, 79 (1950).

(8) H. Stammreich and R. Forneris, *J. Chem. Phys.*, **21**, 944 (1953).

(9) H. Stammreich, O. Sala, and R. Forneris, *An. Acad. Brasil. Cienc.*, **25**, 375 (1953).

(10) H. Stammreich and R. Forneris, *J. Chem. Phys.*, **22**, 1624 (1954).

(11) H. Stammreich and R. Forneris, *Spectrochim. Acta*, **8**, 46 (1956).

(12) H. Stammreich, D. Bassi, O. Sala, and H. Siebert, *ibid.*, **13**, 192 (1958).

(13) H. Stammreich, K. Kawai, and Y. Tavares, *ibid.*, **15**, 438 (1959).

(14) H. Stammreich and R. Forneris, *ibid.*, **16**, 363 (1960).

(15) H. Stammreich, R. Forneris, and Y. Tavares, *ibid.*, **17**, 1173 (1961).

(16) S. G. Frankiss, F. A. Miller, H. Stammreich, and T. Teixeira Sans, *ibid.*, **23A**, 543 (1967).

(17) L. A. Woodward and L. E. Anderson, *J. Chem. Soc.*, 1284 (1957).

(18) L. A. Woodward and J. R. Hall, *Spectrochim. Acta*, **16**, 654 (1960).

(19) L. A. Woodward and J. A. Creighton, *Trans. Faraday Soc.*, **58**, 1077 (1962).

(20) L. A. Woodward and M. J. Ware, *Spectrochim. Acta*, **19**, 775 (1963).

(21) H. Cary, W. S. Galloway, and K. P. George, Paper at Molecular Spectroscopy Symposium, Ohio State University, Columbus, Ohio, 1953.

(22) H. L. Welsh, E. T. Stansbury, J. Romanko, and T. Feldman, *J. Opt. Soc. Amer.*, **45**, 338 (1955).

(23) B. P. Stoicheff, *Advan. Spectrosc.*, **1**, 91 (1959).

(24) J. Brandmüller, *Naturwissenschaften*, **21**, 293 (1967).

(25) V. A. Zulov, M. M. Sushchinskii, and I. K. Shuvalov, *Usp. Fiz. Nauk*, **89**, 49 (1966); *Soviet Phys. Usp.*, **9**, 346 (1966).

(26) J. A. Köningstein in ref 1, p 82.

(27) S. P. S. Porto and D. L. Wood, *J. Opt. Soc. Amer.*, **52**, 251 (1962).

B. ROTATIONAL SPECTRA

Unfortunately, no absorption bands are produced by rotations of unperturbed nonpolar molecules, and therefore microwave and far-infrared techniques are valueless for the study of these important compounds. However, Raman spectroscopy, which arises from changes in polarizability rather than dipole, will give data on rotations so long as the molecules do not have spherical symmetry. Transitions between rotational states are all of very low energy, and therefore Raman lines due to these transitions will be close to the exciting line (typically, a series of lines is found within 50 cm⁻¹ of ν_0). Rotational spectroscopy must be carried out in the gas phase where the "concentration" of scatterers is very low and therefore the Raman lines are extremely weak. As a result, very high-dispersion instruments which are, unfortunately, always slow, must be used and require long exposures. A small number of important molecules have been examined including acetylene, benzene, ethylene, and a number of homonuclear diatomics.²³

The most important information obtainable from an analysis of the rotational Raman lines is of a structural nature. An excellent, and quite typical example is to be found in the study of benzene.²⁸ The planar structure was confirmed; the moments of inertia of the protonated and deuterated forms were calculated and the interatomic distance values determined ($\Gamma_{C-C} = 1.397 \text{ \AA}$; $\Gamma_{C-H} = \Gamma_{C-D} = 1.084 \text{ \AA}$). The results were in poor agreement with the X-ray data,²⁹ but re-investigation of the latter subsequently led to a revised calculation and a new value of Γ_{C-C} at 1.392 \AA .

C. VIBRATIONAL SPECTRA

The complete vibrational spectrum of a molecule is frequently only accessible through combination of the infrared absorption (ν_{vib}) and Raman ($\Delta\nu_{\text{vib}}$) data. Indeed, in centrosymmetric systems, no modes of vibration are featured in both effects, most centrosymmetric modes appearing *only* in the Raman spectrum. Clearly then, if a complete knowledge of the vibrational characteristics of a molecule is required (*e.g.*, for normal coordinate analysis and force constant computation), one must record the Raman spectrum of the species. A careful analysis of the number and position of lines appearing in each spectrum and of the effect of polarization on the intensity of the Raman lines will frequently indicate the structure of a molecule. An example of this approach is to be found in the study of trisilylamine³⁰ where the planar (D_{3h}) skeleton was confirmed. A planar molecule of D_{3h} symmetry should have one Raman (polarized)^{30a} line + one ir line + two ir/Raman (depolarized^{30a}) coincident lines, whereas a pyramidal system (C_{3v}) would have two Raman (polarized) lines also occurring in the infrared + two ir/Raman (depolarized) coincident lines. Very convenient sources of information are available on the occurrence of infrared and Raman lines and the structure of the molecules whose vibrations cause them.^{6, 31}

(28) B. P. Stoicheff, *Can. J. Phys.*, **32**, 330 (1954).

(29) E. G. Cox, D. W. J. Cruickshank, and J. A. S. Smith, *Proc. Roy. Soc.*, **A247**, 1 (1958).

(30) E. A. V. Ebsworth, J. R. Hall, M. J. M. Mackillop, D. C. McKean, N. Sheppard, and L. A. Woodward, *Spectrochim. Acta*, **13**, 202 (1958).

(30a) The depolarization ratio ρ_{θ} is defined as the ratio of the intensities measured when the incident electric vector is parallel to the plane containing this beam and the observational direction and that perpendicular to this plane. If for a given Raman line $\rho_{\theta} < 3/4$, the line is described as "polarized." If $\rho_{\theta} \sim 3/4$, the line is "depolarized."

(31) L. A. Woodward, *Quart. Rev. (London)*, **10**, 185 (1956).

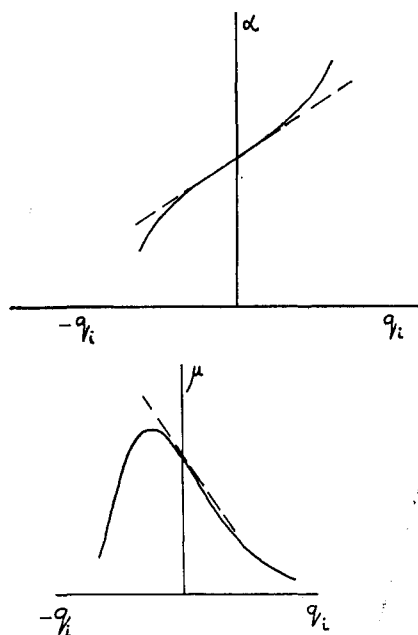

Figure 1. Curves of α and μ against q_i .

A more casual examination of the infrared and/or the Raman spectra of a compound can indicate the presence or absence of functional groups. Some groups are particularly readily identified in their Raman spectrum, e.g., $\text{C}\equiv\text{C}$, $\text{C}=\text{C}$, $\text{C}-\text{S}$, and metal-metal bands, whereas others give rise to strong bands in both effects ($\text{C}=\text{O}$, $\text{C}-\text{H}$, and $\text{C}-\text{halogen}$). Infrared spectroscopy frequently suffers from obscuration of the spectrum due to the intense absorption of certain groups (e.g., hydrogen bonded OH and $\text{C}-\text{F}$ are particularly troublesome), but this is rare in the Raman effect. Both forms of spectroscopy are applicable to quantitative work but, as a general rule, absorption measurements have always been far more reliable in this respect.³²

D. INTENSITY MEASUREMENTS

The measurement of the absolute intensity of Raman lines enables one to compute the value of the bond polarizability derivative ($\partial\alpha/\partial q$, where q = the normal coordinate). As a general rule, it has been shown by Yoshino and Bernstein,³³ among others, that its value is related to the type of bond deforming. Thus, the value approaches 1 \AA^2 for a $\text{C}-\text{C}$ bond, two for an ethylenic link, and three in $\text{C}\equiv\text{C}$. In benzene the value of $(\partial\alpha/\partial q)_{\text{C}-\text{C}}$ is 1.54 \AA^2 .

It seems therefore that there is a linear relationship between the polarizability derivative and the bond order. This is to be contrasted with the very variable values of the dipole moment derivative ($\partial\mu/\partial q$) calculable from infrared intensity data. This difference in behavior can be interpreted from the curves of α against q_i and μ against q_i , shown in Figure 1. In the latter graph the curve shows a maximum, whose position, relative to the equilibrium distance of the bond at $q_i = 0$, is unrelated to the type of bond. The net effect is that $(\partial\mu/\partial q)_0$ can take positive, negative, or zero values, and so have no simple relationship to the dipole moment at $q_i = 0$. However, the shape of the polarizability against normal coordinates curve for a symmetrical vibration is such that as α increases

so too will the slope, and similarly the slope reduces with α . The relationship between intensity and bond order can thus crudely be explained, because α is directly related to the bond strength and hence the bond order.

An excellent review on Raman intensities has appeared recently wherein the unfortunate difficulties in the accurate estimation of intensities are clearly stated.³² Thus, it is clear that Raman spectroscopy is of analytical, structural, and fundamental value in the study of suitable samples. The laser has increased the scope of these studies by making more samples accessible.

II. Experimental

A. INTRODUCTION

Historically, the most important type of laser-Raman spectrometer has employed a pulsed ruby source, the scattered radiation being analyzed with a conventional high-aperture grating spectrograph. In 1964, the first commercial laser spectrometer appeared, but this used a continuous helium-neon source and photoelectric detection. Since then, a number of firms in the United States and France have produced a series of spectrometers, all but one of which consist of a continuous laser source (helium-neon or argon) followed by a double monochromator and photomultiplier detection. It is not intended to give a detailed account of the specialized home-built instruments which have been so important, but a brief review is given in Table I.³⁴⁻⁴¹ The commercially available instruments will be briefly described after the basic units of a modern sophisticated Raman spectrometer have been discussed.

B. THE COMPONENTS OF A LASER-RAMAN SPECTROMETER

1. The Laser

For most purposes, the helium-neon and argon ion lasers are accepted as being most satisfactory for Raman spectroscopy. A laser source has a number of desirable characteristics.

Firstly, it can have a very high intensity (>100 mW in a beam of 3 mm diameter is readily available) in a collimated beam so that the transfer efficiency from the source to the sample can be very high. Secondly, the output can be confined in one laser line (by the use of suitable mirrors in the optical resonator or, in the case of the Ar^+ laser, using a prism inside the cavity). Extraneous lines (i.e., lines which are not "lasing") are of much lower intensity than the main emission, and most can easily be filtered out. Thirdly, the width of the "laser line" is very narrow indeed (typically, much less than 0.1 cm^{-1} for He-Ne and about 0.25 cm^{-1} for Ar^+). Fourthly, the emission outside the "laser line" is negligible in contrast to the discharge lamp where the con-

(34) G. E. Daniliheva, B. A. Zulov, M. M. Sushchinskii, and I. K. Shuvalov, *Soviet Phys. JETP*, **17**, 1473 (1963).

(35) R. C. C. Leite and S. P. S. Porto, *J. Opt. Soc. Amer.*, **54**, 981 (1964).

(36) J. A. Königstein and R. G. Smith *ibid.*, **54**, 1061 (1964).

(37) B. Schröder and M. Stockburger, *Z. Anal. Chem.*, **216**, 117 (1966).

(38) G. W. Chantry, H. A. Gebbie, and C. Hilsum, *Nature*, **203**, 1052 (1964).

(39) M. Delhaye and M. Migeon, *C. R. Acad. Sci., Paris, Ser. B*, **262**, 702, 1513 (1966).

(40) J. Brandmüller, K. Burchardi, H. Hacker, and H. W. Schrötter, *Z. Angew. Phys.*, **23**, 112 (1967).

(41) J. H. R. Clarke, C. Solomons, and K. Balasubrahmanyam, *Rev. Sci. Instrum.*, **38**, 655 (1967).

(32) R. E. Hester in ref 1, p 101.

(33) T. Yoshino and H. J. Bernstein, *Spectrochim. Acta*, **14**, 127 (1959).

Table I
Some Typical Raman Spectrometers for Examining Condensed-Phase Samples

Authors	Source	Detection	Description
Porto and Wood, ³⁷ 1962	Ruby-pulsed, 6943 Å	Photoplate	Grating spectrograph, ~50 pulses needed per exposure; CCl ₄ , CS ₂ , and C ₆ H ₆ examined
Daniliheva, <i>et al.</i> , ³⁴ 1963	Ruby-pulsed, 6943 Å	Photoplate	100 flashes of 1.0–1.8 J used on red-colored compounds; grating spectrograph.
Leite and Porto, ³⁵ 1964	He-Ne continuum, 6328 Å	Photomult	Sample inside cavity, ~100-W/cm ² illumination intensity, S/N ratio ~3000 for $\Delta\nu = 992\text{-cm}^{-1}$ band in C ₆ H ₆ ; grating monochromator.
Königstein and Smith, ³⁶ 1964	He-Ne continuum, 6328 Å	Photomult	Sample outside laser cavity; grating monochromator
Schröder and Stockburger, ³⁷ 1965	Ruby-pulsed, 6943 Å	Photoplate	Sample illuminated and viewed in same direction; interference filter to remove 6943 Å; <i>f</i> /4 Steinheil 3 prism spectrograph; colored and colorless powders examined as pellets
Chantry, Gebbie, and Hilsum, ³⁸ 1964	Ga-As injection laser, 8400 Å	Photoelectric	Used an interferometer and Fourier transformation to produce a spectrum
Delhaye and Migeon, ³⁹ 1965 and 1966	Ruby-pulsed, 0.1 J/pulse	Photoplate	Spectra recorded in $\geq 500 \mu\text{sec}$
Brandmüller, <i>et al.</i> , ⁴⁰ 1967	Ruby quasi continuous, 50 cps, 6943 Å	Photomult	Compared with He-Ne (~60 mW) and found to be superior for some deeply colored compounds; prism dispersion with interference filter before slit
Clarke, <i>et al.</i> ⁴¹ 1967	Ruby-pulsed, 6943 Å	Polaroid film, Type 413	~20 J/pulse; special cell for molten salt studies, right angle viewing; Spex spectrograph (Czerny–Turner grating type)

tinuum is difficult to reduce to acceptable levels. Finally, with good design, a very steady even output can be maintained especially with the He–Ne device, and a high degree of polarization can be obtained.

A number of attempts have been made to compare lasers and discharge lamps, but two will be cited. Evans, Hard, and Murphy⁴² used photoelectric recording and a grating spectrograph–spectrometer to compare a discharge lamp (~2 kW Hg vapor at 4358 and 5461 Å) with a helium–neon laser (output ~30 mW) and came to the conclusion that out to $\Delta\nu = 1000 \text{ cm}^{-1}$ there was little to choose between them. At longer wavelengths, detector sensitivity failure makes a blue source better than a red one.

On the other hand, Hawes, George, Nelson, and Beckwith⁴³ conclude that the $\Delta\nu = 459 \text{ cm}^{-1}$ line of CCl₄ has a similar intensity when 5 ml is irradiated with Hg (4358 Å) as when only 0.03 ml is illuminated with a 65-mW helium–neon laser. They also point out that if the ratio of signal/noise (S/N) is accepted as the criterion for performance of a spectrometer, then S/N falls roughly as $\nu_0^{1/2}$. It is widely held that the detectable scattered intensity is proportional to ν_0^4 , but this neglects detector characteristics. One therefore expects that for given powers red sources should not be grossly inferior to blue.

2. Monochromators

As the Raman effect yields, in essence, a weak set of emissions surrounding an intense monochromatic line, the monochromator in a Raman spectrometer must possess a high discrimination. By this, it is meant that the stray light originating from unwanted reflections inside the monochromator is of low magnitude. Typically, a good single-pass grating monochromator has a stray light intensity of about $I_{\text{source line}} \times 10^{-5}$ at a distance of 10 Å from the wavelength of that line. Since

the intensity of the Raman effect is less than 10^{-8} of that of the Raleigh line, this performance leaves little in hand when examining unfavorable samples. The answer to this problem is to use a double monochromator with which, in theory, one should be able to obtain discriminations in the region of 10^{10} . This was pointed out by Landon and Porto⁴⁴ in 1965, but it must be mentioned that a double monochromator Raman spectrometer had been in production for some years prior to this. The use of gratings rather than prisms is universal in commercial instruments due to the higher efficiency to be gained. In the infrared, of course, gratings are now generally used but there is a problem of order sorting. Since the Raman effect is confined to a very limited wavelength range (*e.g.*, at 6328 Å, a scan from $\Delta\nu = 0$ to 3500 cm^{-1} changes the wavelength by only 25%), there is no problem from high-order spectra. With modern replicated gratings, the well-known problem of “grating ghosts” does not seem to be as serious as it was.

3. Sampling System

The classic method of illuminating a Raman sample is to irradiate it at a right angle to the direction of view. Many laser-Raman spectrometers retain this feature, but considerable variations have found favor. In Figure 2 are drawn a number of typical systems. In 2a the right-angle view system enhanced by multiple passage of the laser beam is shown, while in 2b a seemingly less favorable set-up is drawn. In this arrangement, the sample is viewed at 180° to the illuminating direction. Scattered and reflected radiation reach the spectrometer, and therefore high discrimination is essential. The advantage with the method is its versatility. In 2c is drawn a system which at first sight might seem very inadvisable, but viewing along the incoming laser beam is feasible if the discrimination of the spectrometer is high enough. It has found application where it is only possible to illuminate

(42) M. V. Evans, T. M. Hard, and W. F. Murphy, *J. Opt. Soc. Amer.*, **56**, 1638 (1966).

(43) R. C. Hawes, K. P. George, D. C. Nelson, and R. Beckwith, *Anal. Chem.*, **38**, 1842 (1966).

(44) D. Landon and S. P. S. Porto, *Appl. Opt.*, **4**, 762 (1965).

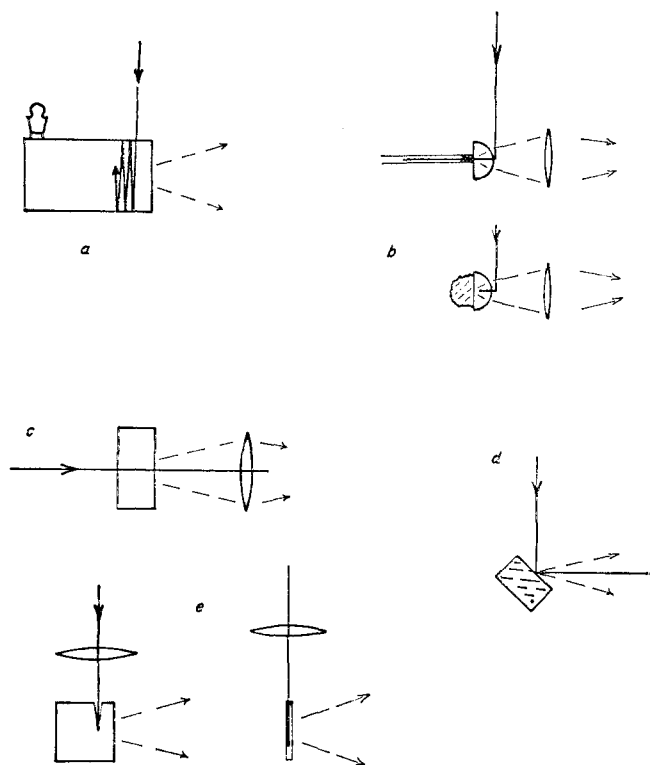

Figure 2. Experimental arrangements for observing Raman spectra with a laser source.

and view in the same direction, *e.g.*, when using "anvil"-type high-pressure cells. In the fourth arrangement (2d), the laser beam is reflected and scattered off an inclined sample. Excellent powder spectra can be achieved with pelleted samples in this arrangement. In the final example (2e), the laser beam is deliberately focused into the sample in order to achieve a very high flux density at the point of view of the monochromator.

For the determination of depolarization ratios in liquids, the first system is probably the most satisfactory, as efficient transfer of radiant energy into the sample is combined with a highly effective system for maintaining the polarization of the laser beam within the sample. One of the advantages of the 180° system is the ability to study extremely small liquid samples using capillary cells. The laser beam is focused down the axis of the tube, the Raman radiation being multiply reflected back into the hemispherical lens. The snag with this method is that depolarization ratios are most unreliable. For example, M. Gall at Southampton has studied the 459-cm⁻¹ line in carbon tetrachloride using this system, with a sample of a few microliters retained in a capillary cell. The depolarization ratio was ~0.6, yet, if a large diameter sample cell was used wherein multiple reflections are avoided, a value of less than 0.02 was found, close to the theoretical value of 0.

Numerous special sampling devices have been contrived for use with commercial spectrometers. A number of these, for use with the 180° system, have been described in the literature by Beattie,⁴⁵ while a low-temperature cell for the same system has been given by Bryant.⁴⁶ It is possible to study powders and solid blocks, melts, liquids, explosives, and micro-solid or liquid samples with this system, by placing the sample

up against the plane surface of the hemispherical collector lens and either leaving it loose or containing it in a glass or other transparent material envelope.

It is also possible to study special samples in the right angle system; *e.g.*, extremely small amounts of sample (~0.04 μl) have been studied successfully by Bailey, Kint, and Scherer⁴⁷ by focusing the laser into a sample retained in a capillary. It is also convenient to study samples at elevated or reduced temperatures, and some of the instrument manufacturers have designed equipment for these experiments, *e.g.*, the low-temperature "transfer plate" for the Coderg spectrometer.

4. Detector Systems

Basically, the vast majority of Raman spectrometers which incorporate photoelectric detection systems consist of a photomultiplier-amplifier-recorder chain. There are variations, however, in the operation of the amplifier. The most popular system is that of synchronous or lock-in amplification. The signal is interrupted (or chopped) at a frequency usually of several hundreds of cycles per second; the ac signal is amplified, passed through a filter network, tuned to the chopping frequency, and rectified. This device, with its narrow band width, effectively improves the S/N ratio at the recorder over that at the detector output. Its rival is the technique of "photon counting." This system relies on the fact that the noise from the photomultiplier consists primarily of low-energy and high-energy pulses, and the signal is found between these limits. Use of blocking circuits will then tend to discriminate the signal from the noise, the pulses remaining being effectively counted and recorded. A third system described as intensity correlation has been described but has as yet been little applied to Raman spectroscopy.⁴⁸ Dc amplification is of value particularly for recording strong emissions. Cooling the photomultiplier or placing it in a magnetic field tends to reduce noise. The former feature is incorporated in some commercial spectrometers.

C. COMMERCIALY AVAILABLE INSTRUMENTS

It is now relevant to consider the commercially available spectrometers. In the interests of brevity, a series of specifications is given in Table II containing brief details on the most important contenders in the field. The instruments are listed alphabetically. It is not intended that these details should be taken as a description of the instruments but rather as a guide or indication of the type of construction offered by each manufacturer. Prices are included but are very approximate.

A new instrument of low cost but including a double monochromator was shown by Coderg in April. Instruments by Hilger and Watts, London N.W. 1., England, and the Japanese Optical Co. are under development.

A new instrument by Spectra Physics, Inc., Mountain View, Calif., has been recently announced.

D. INSTRUMENTAL DEVELOPMENTS

Two fields where active development is being concentrated are (a) the increase in versatility and (b) the increase in recording speed. All the commercial manufacturers are interested in the first since it is obvious that for analytical and development

(45) I. R. Beattie, *Chem. Brit.*, **3**, 347 (1967).

(46) J. Bryant, *Spectrochim. Acta*, **24A**, 9 (1968).

(47) G. F. Bailey, S. Kint, and J. R., Scherer, *Anal. Chem.*, **39**, 1040 (1967).

(48) Y.-H. Pao, R. N. Zitter, and J. E. Griffiths, *J. Opt. Soc. Amer.*, **56** 1133 (1966).

Table II

Source	Sampling	Monochromator	Detection	Special features
Cary 81, Cary Instruments, Monrovia, Calif.				
Spectra Physics Type 125, 60 mW, He-Ne 6328 Å	180° system; 90° can be used	Double-grating Littrow, 4-in. high slits; double slits incorporated	Pm and ac amp. Recorder coupled to $\Delta\nu$	Beam splitter incorporated to illuminate the high slits; versatility of machine proved; cost high, ~\$40,000
Ar ⁺ laser also available				
Coderg PH1, Soc. de Conversion des Energies, Clichy, France				
Uses commercial sources; He-Ne 6328 Å, Ar ⁺ 4880°, or continuous ruby 6943 Å	Right angle system with or without focusing in sample	Double-grating Czerny-Turner system	Pm and dc amp. Recorder noncoupled	Numerous "transfer plates" available to examine solids, liquids, microsamples at low or high temp; cost ~\$30,000
Huet R50, Soc. Generale d'Optique, Paris 19 ^e , France				
Generale d'Electricite; He-Ne 50 mW, 6328 Å	Right angle system	Single-grating Czerny-Turner system; interference filter before detector	Pm and ac amp. Recorder noncoupled	Very simple design; cost low.
Jarrell-Ash 25-300, 590 Lincoln St., Waltham, Mass.				
He-Ne, Ar ⁺ , or Kr ⁺ sources recommended	Right angle or along laser systems	Double-grating Czerny-Turner system; Servo controlled slits; const width in cm ⁻¹ maintained	Pm thermoelectrically cooled; photon counting; noncoupled recorder	Large sample chamber; cost ~\$45,000
Perkin-Elmer LR1, Norwalk, Conn.				
P.E. 211-0580; He-Ne 6 mW, 6328 Å	Right angle system	Double-pass Walsh-Litt row grating type	Pm and low-frequency ac amp. Recorder noncoupled	First commercial spectrometer to appear; considerable number in use; number of sampling systems available; cost ~\$25,000
New model (LR-3) just announced				
Spex, Metuchen, N. J.				
Spectra Physics Type 125; 60 mW He-Ne 6328 Å	Right angle system; reflection off inclined solids; gases	Double-grating Czerny-Turner system	Dc or photon counting; noncoupled recorder; pm cooled	Resolution proved to be very good; rotn and rotn-vibn spectra have been shown; cost ~\$35,000
Ar ⁺ and Kr ⁺ sources also available				

work versatility must not be sacrificed to resolution or photometric performance. At present, it seems (but is by no means proved as yet) that the 180° sampling system has advantages in this respect, but new developments are to be expected using other systems, *e.g.*, the work of Freeman.^{48a}

Recently Delhaye⁴⁹ has given details of experiments with the Coderg spectrometer using a scan system modified to achieve a rate of scan of 1000 cm⁻¹/sec. Excellent resolution was achieved even on colored compounds such as azobenzene. Continuous lasers were used as sources. He also described experiments using pulsed ruby laser sources, image convertors, and Vidicon television camera tubes. Image intensifiers are

also used in collaboration with photographic plates and continuous sources.

As examples of his success, Delhaye recorded spectra of benzene (in ~10⁻³ sec) and of the reaction NOCl → NO + 0.5Cl₂ (half-life of about 10⁻⁸ sec in the gas phase). It seems likely that Raman spectroscopy may well prove more satisfactory than high-speed infrared for studying the vibrational spectra of transients since this process is fundamentally more rapid. The main reason is that it is possible to record the complete spectrum, or a large portion of it, on photographic emulsions or image converter tubes, during the lifetime of the transient. In the infrared, photoelectric recording detects radiation, whose wavelength range only covers the slit width, at any one time. As a result there are very considerable signal/noise ratio problems in high-speed infrared measurements. In addition, it is far simpler and more economical to record

(48a) S. K. Freeman and D. O. Langden "The Spex Speaker," Vol. VIII, Spex Industries, Inc., Metuchen, N.J., 1968, p 4.

(49) M. Delhaye, 4th Conference on Molecular Spectrometry, Petroleum Institute, Brighton, April 1968.

spectra at high frequencies (*i.e.*, in the visible as opposed to the infrared).

Further advantages of Raman measurements over infrared are (a) the information on transient species given by depolarization data (this can be particularly valuable in studying radicals, which often possess high symmetry); and (b) the symmetrical nature of transients which means more information can be obtained from Raman spectroscopy than infrared, because most symmetric stretching frequencies are Raman rather than infrared active.

III. Raman Spectra of Gases

A. INTRODUCTION

The Raman spectra of gases contain more fundamental information than those of condensed-phase species, because the freedom to rotate enables rotational and vibration-rotational bands to be resolved. Thus, the interaction between the rotation of a molecule and incident radiation is important. Raman scattering appears when there is a change in the polarizability during a transition, and this can occur if the symmetry of the rotating molecule is not spherical. In these cases, the polarizability is anisotropic and the selection rules, which are more extensive than those for absorption, allow the rotational quantum number, J , to change by one or two, or remain unaltered. For example, a linear molecule has a pure rotational spectrum arising from $\Delta J = \pm 2$, whereas symmetric and asymmetric tops have four envelopes originating from $\Delta J = \pm 1, \pm 2$. In these spectra the $\Delta J = 0$ transition is buried in the Rayleigh scattering.

Other selection rules occur governing transitions between energy levels split by the quantum number K , as in symmetric tops, or by l -type doubling;⁶ however, the unique feature appearing in the Raman effect, compared to absorption, is the addition of bands due to $\Delta J = \pm 2$. Thus, a vibrational band may consist of five envelopes, O, P, Q, R, and S, corresponding to $\Delta J = -2, -1, 0, 1, \text{ and } 2$, respectively, and it follows that two independent values of the rotational constant may be obtained from the spacing of the lines within a band. This leads to the calculation of specific values of constants such as A and ξ (where A is the rotational constant related to the moment of inertia along the principle axis of a symmetric top molecule and ξ is the constant for vibrational angular momentum⁶⁰). On the other hand, A and ξ can only be computed as a ratio from absorption measurements on a non-degenerate band, *e.g.*, ν_2 in the spectrum of monodeuterio-methane.

The rise and fall in the intensity of the rotational envelopes of a vibrational band can indicate the symmetry of the vibration and may even pinpoint the group symmetry of the molecule.⁶¹ Careful analysis of all the data, especially if the rotational lines are well resolved, can give values for the degree of anharmonicity, Coriolis effects, centrifugal distortion, and other parameters.

The basic experimental problem is the resolution of the closely spaced rotational fine structure in the spectrum. The spacing is inversely related to the moment of inertia of the molecule, and hence only small molecules are easily examined in detail. As a guide it can be assumed that it is very difficult

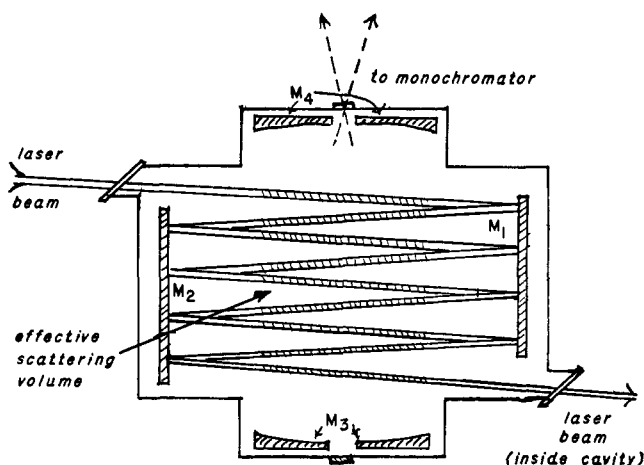

Figure 3. Multipass cell for studying Raman spectra of gases: M_1 and M_2 , dielectric mirrors to deflect laser beam; M_3 and M_4 , mirrors to collect scattered light.

to resolve fine structure in most molecules with a molecular weight of more than 100. Absorption measurements in the far-infrared suffer from similar experimental limitations, but the intrinsically higher resolution possible in the microwave permits the study of heavier molecules. Rotations of centrosymmetric molecules do not give rise to rotations active in absorption, and therefore Raman measurements are informative. Unfortunately, spherically symmetric molecules have constant polarizability on rotation and are therefore not Raman active. They can be hyper-Raman active in rotation (see section VII. C.3).

B. ROTATIONAL SPECTRA

The data recorded⁵²⁻⁵⁴ in the literature are confined to tests of various experimental systems. No "new" spectra have appeared to date. In the first report⁵² a straight cell containing the sample was enclosed within the cavity of a helium-neon laser and was therefore exposed to a high power density at 6328 Å. However, 59 hr of exposure was required to record the rotational spectrum of methylacetylene. The performance of the equipment was subsequently improved by incorporating a lens to focus the laser radiation inside the gas cell. In addition, a multipass cell was devised⁵⁴ such that nine traverses occurred through the cell, again within the laser cavity. The use of more than nine traversals seriously attenuated the power of the laser. Details of this system can be seen in Figure 3. Using these devices photographic exposure times have been reduced to about 10-20 hr.

While confined to photographic detection, laser-Raman techniques would be used only in restricted fields, but considerable strides have been made in the development of photoelectric recording. Spectra of oxygen, nitrogen, CO_2 , and methylacetylene among others have been shown as proof of the effectivity of these systems.

Another fascinating report to appear recently concerned the pure rotation spectrum of carbon dioxide while under dis-

(50) E. H. Richardson, S. Brodersen, L. Krause, and H. L. Welsh, *J. Mol. Spectrosc.*, **8**, 406 (1962).

(51) D. W. Leppard, D. M. C. Sweeney, and H. L. Welsh, *Can. J. Phys.*, **40**, 1567 (1962).

(52) A. Weber, "The Spex Speaker," Vol. XI, Spex Industries, Inc., Metuchen, N. J., 1966.

(53) A. Weber and S. P. S. Porto, *J. Opt. Soc. Amer.*, **55**, 1033 (1965).

(54) A. Weber, L. E. Cheesman, S. P. S. Porto, and J. J. Barrett, *ibid.*, **57**, 19 (1967).

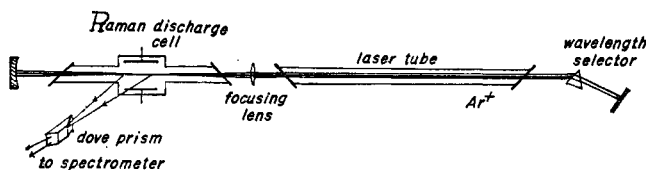

Figure 4. Optical arrangement for the study of the rotational Raman spectrum of a CO_2 discharge.

charge.⁵⁵ The apparatus used is drawn in Figure 4. It was observed that under discharge new lines appeared between those for the gas in a normal condition.

C. VIBRATIONAL AND VIBRATION-ROTATIONAL SPECTRA

Although vibration-rotational spectra are much weaker than pure rotation lines, the experimental developments in the field have been so rapid that Bernstein⁵⁶ has shown spectra of methane containing clearly resolved vibration-rotational lines while carbon dioxide has been studied by Weber.⁵⁴

Perhaps the first example of laser-Raman spectroscopy being used to solve a chemical problem must be credited to Gasner and Claassen.⁵⁷ These authors were concerned with the volatile species xenon hexafluoride. Using a Spex monochromator and a Spectra-Physics Model 125 (He-Ne) laser, they examined the hexafluoride in the solid (at 40°), liquid (at 54 and 92°), and gaseous (at 94°) phases. The spectra could be interpreted in terms of tetramers for the condensed phases in agreement with structural work on the crystals, but the vapor which had a "peculiar" spectrum has a vapor density confirming a monomeric structure. The vibrational results on the vapor were as follows: Raman, 609 m br (p), 520 s br (dp), 206?; infrared, 613 and 520 cm^{-1} .

The dual activity and unusual intensities (the polarized line in an octahedral molecule is usually strongest) indicate a lower symmetry than octahedral for the hexafluoride in agreement with some theoretical predictions.⁵⁸

In an open-ended experiment,⁵⁹ Raman lines due to nitrogen and oxygen were observed at a range of up to 1.2 km using a nitrogen-pulsed laser (3371 \AA of 100-kW power) and reflecting telescope coupled, through a variable filter, to a photomultiplier.

D. CONCLUSION

Clearly, there are as yet few examples of the application of laser-Raman spectroscopy to chemical problems involving gases, but the potential of the method has been demonstrated. It will definitely be possible to examine the rotational spectra of volatile compounds of high symmetry and to obtain interatomic distance values. The study of discharges will also be of great interest while the number of gases which will be examined for vibrational or vibration-rotational bands will increase rapidly.

IV. Raman Spectra of Inorganic Compounds

A. INTRODUCTION

The first laser-Raman results of primary interest to the chemical community described experiments on inorganic compounds.⁶⁰⁻⁶³ The value of Raman spectroscopy in inorganic chemistry stems from the frequently high symmetry of interesting compounds. If, for example, we consider the square-planar species of type MX_2Y_2 , we see this point nicely demonstrated. The vibrational spectra of the *cis* species are largely coincident; *i.e.*, all modes have dual (Raman and infrared) activity, and therefore their vibrational characteristics have been moderately well understood for some time.⁶⁴ Unfortunately, all modes involve movement of the central atom M, and therefore comparisons of metal-ligand frequencies in ranges of compounds are not strictly permissible, although it is frequently attempted. In the case of the *trans* system, this latter problem does not apply; *i.e.*, the symmetrical X-M-X and Y-M-Y stretching modes do not involve any displacement of the metal atom, and therefore comparisons of frequencies in homologous series of compounds are of value. Unfortunately these modes are infrared silent and Raman active and therefore have not been adequately studied to date.

Coordinate analysis is frequently the purpose of study; thus in symmetrical systems it is essential to record the Raman spectrum. Further, infrared assignments are frequently of the needle-in-a-haystack variety when isotopic substitution or vapor-phase band contour analyses are impossible. Raman results on solutions and the observation of depolarization ratios, in addition to the infrared results, make the assignments far more meaningful.

In the study of coordination compounds and particularly those of low solubility, the laser source has increased the versatility of the technique. In addition, spectra of highly reactive and photosensitive species have been reported where it would have been impossible to record spectra using discharge sources. Typical examples of these applications will now be cited.

B. COLORED SYMMETRIC SYSTEMS

The complex anions of formula MX_4^{n-} ($\text{M} = \text{Pt}, \text{Pd}, \text{or Au}$ and $\text{X} = \text{Cl}, \text{Br}, \text{and I}$) are of importance, and some of these compounds were examined some years ago. Recently, spectra of the full set of nine salts (with one exception, K_2PdI_4) have been recorded as powders using a helium-neon laser source.⁶⁵ These spectra were obtained with great facility even though some of the salts are opaque in bulk, whereas the original data was obtained photographically after long exposures on solution samples. The results, new and old, are included in Table III.⁶⁶

One of the problems in comparing infrared and Raman results in the past has been the question of frequency shifts with phase changes. Infrared spectra of species normally insoluble in organic solvents are usually recorded as Nujol

(55) J. J. Barrett and J. Rigden, 9th European Congress on Molecular Spectroscopy, Madrid, 1967.

(56) H. J. Bernstein, ref 55.

(57) E. L. Gasner and H. H. Claassen, *Inorg. Chem.*, **6**, 1937 (1967).

(58) L. S. Bartell, *J. Chem. Phys.*, **46**, 4530 (1967).

(59) D. A. Leonard, *Nature*, **216**, 142 (1967).

(60) W. Hayden Smith and G. E. Leroi, *J. Chem. Phys.*, **45**, 1778 (1966).

(61) B. Schröder and M. Stockburger, *Z. Anal. Chem.*, **216**, 1 (1966).

(62) T. E. Haas and J. R. Hall, *Spectrochim. Acta*, **22A**, 988 (1966).

(63) P. J. Hendra, *Nature*, **212**, 179 (1966).

(64) D. M. Adams, "Metal-Ligand and Related Vibrations," E. Arnold, Ltd., London, 1967.

(65) P. J. Hendra, *J. Chem. Soc., A*, 1298 (1967).

(66) A. Maccoll, *J. Proc. Roy. Soc. N. S. Wales*, **77**, 130 (1944).

Table III
Laser-Raman Spectra of Square-Planer Species of Formula MX_4^{n-} ($\Delta\nu$, cm^{-1})

Formula	$\nu_1(A_{1g})$	$\nu_2(B_{2g})$	$\nu_4(B_{1g})$	Lattice modes	Urey-Bradley force constants			k_t^a
					H	F	K	
K_2PdCl_4	310 s	275 w	198 s	...	0.097	0.194	1.62	1.44
K_2PdBr_4	192 s	165 w	125 m	...	0.07	0.205	1.28	1.13
K_2PtCl_4	329 s	302 mw	194 mw	76 s	0.110	0.164	1.99	1.99
$\text{PtCl}_4^{2- b}$	332 s (p)	314 m	170 w	...	0.114	0.127	1.72	1.71
K_2PtBr_4	205 s	190 m	125 m	0.135	1.19	0.9
$\text{PtBr}_4^{2- b}$	208 s (p)	194 m	0.072	0.146	2.22	2.06
K_2PtI_4	142 m	126 s	0.031	0.158	1.84	1.81
KAuCl_4	349 s	324 m	183 mw	...	-0.078	0.332	0.97	1.20
$\text{AuCl}_4^{- b}$	350 s (p)	326 ms	173 w
KAuBr_4	213 s	196 m	106 v
$\text{AuBr}_4^{- b}$	215 s (p)	197 m	104 w
KAuI_4	148 m	110 s	75 m

^a k_t = stretching force constant as defined by Maccoll.⁶⁶ Previous studies using discharge sources on solutions by Maccoll⁶⁶ (AuCl_4^-) and Stammreich and Forneris (AuCl_4^- , AuBr_4^- , and PtCl_4^{2-}).¹⁴ ^b Results obtained from solutions, remainder as solids.

mulls. On the other hand, as noted above, compounds were usually examined in the Raman as solutions. Owing to the lack of ability of the techniques to study a typical compound in the same condensed phase, the importance and significance of frequency shifts on phase change have had to be based on extrapolated data or theory. Hiraishi and Shimanouchi⁶⁷ have forecast serious shifting of this type in the deformation modes in such important type species as $\text{M}^1_2\text{PtCl}_4$ and $\text{M}^1_2\text{PtCl}_6$. The ability to examine solid and solution samples using laser techniques has enabled these predictions to be largely confirmed,⁶⁸ thus stressing the considerable caution required when comparing solid and solution results.

The almost opaque series of hexacoordinated halogeno anions MX_6^{n-} (where $\text{M} = \text{Re}, \text{Os}, \text{Ir}, \text{Pd}, \text{Pt}$, and $\text{X} = \text{Cl}$ and Br) have also been studied in the solid phase.⁶⁹ As in the MX_4^{n-} anions, the Raman spectra should contain three bands in each case, whereas the infrared should show the frequency of only two modes (the asymmetric MX stretch and deformation). Other compounds examined recently have formulas M^1_2SeX_6 and M^1_2TeX_6 , where $\text{M}^1 = \text{K}, \text{Rb}, \text{Cs}, (\text{NH}_4)$, and (pyH) , and $\text{X} = \text{Cl}, \text{Br}$, and I , both in the solid phase and in solution.⁷⁰ Adams and Morris have published a series of papers on halides and complex halides including the anions SnCl_6^{2-} , PbCl_6^{2-} , TeCl_6^{2-} , TeBr_6^{2-} , and TeI_6^{2-} in addition to hexahalogeno platinates.⁷¹⁻⁷³ Beattie and coworkers^{74,75} have also been active in this field and their results in addition to the other new data on hexahalo species are collected in Table IV.

Other highly symmetrical halogeno species have been studied including $\text{Mo}_6\text{Cl}_8^{4-}$. Hartley and Ware⁷⁶ studied both solution and solid-phase samples using He-Ne excitation and were able to assign the ten Raman bands they observed to fundamental modes and to compute a metal-metal force

Table IV
Laser-Raman Spectra of Octahedral Species of Formula MX_6^{n-} ($\Delta\nu$, cm^{-1})

Formula	$\nu_1(A_{1g})$	$\nu_2(E_g)$	$\nu_3(F_{2g})$	Comments
M_2SnCl_6	323-306	250-241	184-165	Solid samples
M_2PbCl_6	296-279	231-209	157-139	From ref 71
PbCl_6	202	Collected data
BiCl_6^{3-}	259	222	108	From ref 74
SbCl_6^{3-}	267	214	111	
InCl_6^{3-}	277	193	149	
TlCl_6^{3-}	264	192	135	
M_2SeCl_6	286-280	257-242	165-162	Collected data
M_2TeCl_6	299-287	250-247	143-131	
M_2SeBr_6	179-166	157-151	105	From ref 70
M_2TeBr_6	178-169	155-148	90-70	$\text{M} = \text{organic and inorganic ions, solids, and solns}$
M_2SeI_6	113	113	...	
M_2TeI_6	105	105	...	
M_2TeCl_6	302-280	263-243	150-137	From ref 72
M_2TeBr_6	180-167	160-144	96-73	
K_2OsCl_6	345	274	165	Results on solid samples
K_2IrCl_6	352	225	190	
K_2PdCl_6	317	292	164	From ref 69
K_2PdBr_6	198	176	100	
K_2PtCl_6	344	320	162	
PtCl_6^{2-}	343 (p)	322	159	Aqueous soln
K_2PtBr_6	215	191	110	Solid From ref 68
$\text{M}^1_2\text{PtCl}_6$	353-335	328-312	186-160	Powders
K_2PtBr_6	217	195	115	Powder Ref 73

(67) J. Hiraishi and T. Shimanouchi, *Spectrochim. Acta*, **22A**, 1483 (1966).

(68) P. J. Hendra, *ibid.*, **23A**, 2871 (1967).

(69) P. J. Hendra and P. J. Park, *ibid.*, **23A**, 1635 (1967).

(70) P. J. Hendra and Z. Jovic, *J. Chem. Soc., A*, 600 (1968).

(71) D. M. Adams and D. M. Morris, *ibid.*, 1669 (1967).

(72) D. M. Adams and D. M. Morris, *ibid.*, 2067 (1967).

(73) D. M. Adams and D. M. Morris, *ibid.*, 1666 (1967).

(74) T. Barrowcliffe, I. R. Beattie, P. Day, and K. Livingston, *ibid.*, 1810 (1967).

(75) I. R. Beattie, T. Gilson, K. Livingston, V. Fawcett, and G. A. Ozin, *ibid.*, 712 (1967).

(76) D. Hartley and M. J. Ware, *Chem. Commun.*, 912 (1969).

constant of $1.6 \text{ m dyn } \text{Å}^{-1}$. The trihalide ions are normally linear, but in the crystalline phase they can be distorted; e.g., the spectrum of dark brown CsIBr_2 indicates a C_{2v} structure for the ion.⁷⁷ The spectrum of the Br_3^- and Br_5^- anions were included in a study of sundry oxy- and halobromine salts in which the BrO_2^- ion was shown to have a

(77) G. C. Hayward and P. J. Hendra, *Spectrochim. Acta*, **23A**, 2309 (1967).

Table V
Laser-Raman Spectra of Coordination Compounds

Compounds	Metal-ligand stretching vibration frequencies, cm^{-1}				Comments
Te square-planar complexes of thiourea and substd thioureas	$\nu_{\text{Te-S}}$	230			Solns and solids from ref 88
	$\nu_{\text{Te-Cl}}$	245			
	$\nu_{\text{Te-Br}}$	150			
	$\nu_{\text{Te-I}}$	110			
$\text{Pd}(\text{NH}_3)_4\text{Cl}_2$ <i>trans</i> - $\text{Pd}(\text{NH}_3)_2\text{Cl}_2$ <i>trans</i> - $\text{Pt}(\text{NH}_3)_2\text{X}_2$ (X = Cl, Br, and I)	$\nu_{\text{Pt-N}}$	540-529	$\nu_{\text{Pd-N}}$	494	Solids, from ref 87
	$\nu_{\text{Pt-Cl}}$	318			
	$\nu_{\text{Pt-Br}}$	206			
	$\nu_{\text{Pt-I}}$	153			
<i>trans</i> - MX_2Y_2 (M = Pt, Pd; X = Cl, Br, I; Y = Me_3S , Me_3Se , and Me_3Te)	$\nu_{\text{M-S}}$	345	$\nu_{\text{M-Cl}}$	330-300	Solids, from ref 90 and 91
	$\nu_{\text{M-Se}}$	175	$\nu_{\text{M-Br}}$	215-208	
	$\nu_{\text{M-Te}}$	165	$\nu_{\text{M-I}}$	~150	
	Internal modes little affected by complex formation				
ML_4^{2+} and <i>trans</i> - ML_2X_2 (L = thiourea and selenourea; X = Cl, Br, I; M = Pt, Pd)	$\nu_{\text{Pt-S}}$	~270	$\nu_{\text{Pd-S}}$	~255	From ref 92, solids and solns
	$\nu_{\text{Pt-Se}}$	~190	$\nu_{\text{Pd-Se}}$	~180	
<i>cis</i> - MX_2Y (M = Pd, Pt; X = Cl, Br, I; Y = Me_3P , Me_3As , and Me_3Sb)	$\nu_{\text{M-Cl}}$	300-275	$\nu_{\text{M-P}}$	400-360	Solids, from ref 93
	$\nu_{\text{M-Br}}$	200-185	$\nu_{\text{M-As}}$	~270	
	$\nu_{\text{M-I}}$	~140	$\nu_{\text{M-Sb}}$	~200	

C_{2v} structure.⁷⁸ Recent developments in the techniques for studying powders using discharge sources have been so successful that spectra of deeply colored species of the trihalide anion type have been reported during 1967.⁷⁹

Other colored symmetric molecules to be studied using laser sources include S_8 which was examined independently by two groups^{80,81} who produced full assignments of their observations. A spectrum of Se_8 is also available.⁸²

Some other chalcogenides have also been examined including CO_2 and N_2O as powders,⁸⁸ C_3S_2 ,⁸⁰ and CS_3^{2-} ⁸¹ and also the tetrahedral anions MnO_4^- ,⁸⁴ and MoS_4^{2-} and WS_4^{2-} .⁸⁵ Everyone is familiar with the intense color of the permanganate ion, but these thioanions are yellow and brown, respectively. All these tetrahedral compounds were studied successfully using on-axis illumination with a He-Ne laser.

Raman study of symmetrical systems has not been confined to simple molecules since two reports have appeared on ammine complexes. In the first, Haas and Hall⁸² showed the spectrum of a familiar octahedral cation $[\text{Co}(\text{NH}_3)_6]^{3+}$ and were able to confirm that the metal-nitrogen stretching vibration frequency is close to 500 cm^{-1} , in agreement with the suggestions of Powell and Sheppard.⁸⁶ A similar conclusion was reached regarding the planar amines $[\text{Pd}(\text{NH}_3)_4]\text{Cl}_2$ and the molecules *trans*- $[\text{Pt}(\text{NH}_3)_2\text{X}_2]$ (X = Cl, Br, and I).⁸⁷

A considerable number of complexes containing organic donor molecules have been studied recently, and a summary

of the data accumulated is given in Table V.⁸⁸⁻⁹³ It will be seen that the main effort has been concentrated on a serious study of the metal-ligand bond, a field of great interest to inorganic chemists. Definite frequencies for metal N, S, Se, Te, P, As, and Sb stretching vibrations have been proposed. For many of the compounds considered, the addition of Raman results did *not* clarify the previously accepted assignments of the infrared data but rather tended to complicate the assignment problem. Although, at first sight, it may seem straightforward to assign infrared spectra to fundamental modes, the suggestions are not reliable. In the paper on MX_2Y_2 (X = Cl, Br, and I; Y = Me_3P , Me_3As , and Me_3Sb) assignment of the spectra was impossible without those of the triethyl and perdeuteriotrimethyl derivatives.

C. COMPOUNDS OF LOWER SYMMETRY

A number of asymmetric systems, often highly colored, have also been examined, *e.g.*, the chalcogen tetrahalides (trigonal bipyramidal with one-equatorial position vacant) and the dichalcogen dihalides (C_2 symmetry like hydrogen peroxide).

The structure of the tetrahalides has been the subject of some discussion, since it is possible for them to adopt a covalent structure (mentioned above), an ionic one, MX_3^+X^- , or a charge-transfer structure, $\text{MX}_2 \leftrightarrow \text{X}^-\text{X}_2^+$. Since one of the authors is involved in this fracas, no attempt will be made to adjudicate! Laser-Raman and far-infrared spectra have been

(78) J. C. Evans and G. Y.-S. Lo, *Inorg. Chem.*, **6**, 1483 (1967).

(79) A. G. Maki and R. Forneris, *Spectrochim. Acta*, **23A**, 867 (1967).

(80) L. A. Nimon, V. D. Neff, R. E. Cantley, and R. O. Buttlar, *J. Mol. Spectrosc.*, **22**, 105 (1967).

(81) J. Berkowitz, W. A. Chupka, E. Bromels, and R. L. Belford, *J. Chem. Phys.*, **47**, 4320 (1967).

(82) G. C. Hayward, Ph.D. Thesis, London, 1967, p 34.

(83) J. E. Cahill, K. L. Treuil, R. E. Müller, and G. E. Leroi, *J. Chem. Phys.*, **47**, 3678 (1967).

(84) P. J. Hendra, *Spectrochim. Acta*, **24A**, 125 (1968).

(85) A. Müller, B. Krebs, and G. Gattow, *ibid.*, **23A**, 2809 (1967).

(86) D. B. Powell and N. Sheppard, *J. Chem. Soc.*, 3108 (1956).

(87) P. J. Hendra, *Spectrochim. Acta*, **23A**, 1275 (1967).

(88) P. J. Hendra and Z. Jovic, *J. Chem. Soc., A*, 735 (1967); 911 (1968).

(89) I. R. Bealtie and G. A. Ozin, *ibid.*, 2373 (1968).

(90) J. R. Allkins and P. J. Hendra, *ibid.*, 1325 (1967).

(91) J. R. Allkins and P. J. Hendra, *Spectrochim. Acta*, **24A**, 1305 (1968).

(92) P. J. Hendra and Z. Jovic, *ibid.*, **24A**, 1713 (1968).

(93) P. J. Hendra and P. J. Park, *ibid.*, **25A**, 227 (1969).

recorded on SCl_4 , SeX_4 ($X = \text{Cl}$ or Br), and TeX_4 ($X = \text{Cl}$ or Br).⁹⁴⁻⁹⁷

Two independent studies of the species of type X_2Y_2 ($\text{Y} = \text{S}, \text{Se}; \text{X} = \text{Cl}, \text{Br}$) have appeared. In the first, the laser-Raman spectrum of sulfur monochloride was described,⁹⁸ but in the second the set of four compounds was studied.⁹⁹ In this latter paper it was shown that the previously accepted results were in error as the compounds were heavily contaminated with disproportionation products. The facility with which laser-Raman spectra may be recorded makes it possible to examine crude products made in different ways and also to follow the progress of purification *in situ*.

D. PHOTOSENSITIVE COMPOUNDS

It was pointed out in the introductory section of this review that the use of red lasers enables one to examine photosensitive materials which would be decomposed in the comparatively "dirty" emission of a discharge source. As an example, the compound bis(trifluoromethyl)diselenide may be cited. This compound decomposes to selenium in a mercury arc, but an excellent spectrum was recorded using a red-laser source. In fact, the spectrum is included with analogs such as Me_2S_2 and Me_2Se_2 in a paper on the chalcogen-chalcogen bond.¹⁰⁰ The torsional characteristics of these compounds have been interpreted as indicating some π character in this bond.¹⁰¹ The torsional modes are of very low frequency ($<100 \text{ cm}^{-1}$), but the narrow spectral line width of the laser source enabled bands to be observed even at $\Delta\nu = 50 \text{ cm}^{-1}$.

Another very photosensitive compound to be examined recently was nitrogen trichloride. This extremely dangerous explosive is sensitive to almost any stimulus and especially short wavelength radiation but, using an explosion-proof cell, an excellent spectrum complete with depolarization data was recorded.¹⁰² The frequencies are given for this pyramidal (C_{3v}) molecule in Table VI.

Another category of photosensitive species are the carbonyl compounds. The stability varies and some decompose even in red radiation. Recently¹⁰³ a report has appeared on the species $\text{V}(\text{CO})_6^-$, $\text{Cr}(\text{CO})_6$, $\text{Mo}(\text{CO})_6$, $\text{W}(\text{CO})_6$, and $\text{Re}(\text{CO})_6^+$. Twelve of the thirteen frequencies for the vanadium compound and eleven in the rhenium case have been identified and force constants calculated. It has been shown that the force constants ($k_{\text{M-C}}$) and therefore probably the π character in the metal-carbon bond fall in the order $\text{V} > \text{W} > \text{Cr} > \text{Re}$.

Other carbonyl compounds to be studied include the pentacarbonyl hydrides and halides of Mn and Re,^{104, 105} the metal cluster compound $\text{Ir}_4(\text{CO})_{12}$,¹⁰⁶ and a series of metal-metal

Table VI

Laser-Raman Spectra of Nitrogen Trichloride Compared with Data on Related Species ($\Delta\nu, \text{cm}^{-1}$)

Compound ^a	$\omega_{3,5}$	ω_6	$\omega_{2,4}$	ω_1
NCl_3	254 m (dp)	347 s (p)	637 vw (dp)	535 s (p)
PCl_3	190 s (dp)	257 ms (p)	480 w (dp)	510 s (p)
AsCl_3	159 s (dp)	193 ms (dp)	370 ms (dp)	410 s (p)
SbCl_3	134 s	165 m	320 s	360 s

^a NCl_3 results from ref 102; remainder extracted from ref 4.

bonded compounds containing Co-Hg, Mn-Hg, and W-Hg bonds.¹⁰⁷ A related and deeply colored molecule to be examined thoroughly was cyclopentadienenickel nitrosyl.¹⁰⁸ It was possible to assign modes due to the acyl group on the basis of a D_{5h} model (*i.e.*, an unperturbed cyclopentadiene ring).

E. MISCELLANEOUS EXAMPLES

Raman spectroscopy has always been accepted as a powerful tool for the study of water and aqueous solutions. Walrafen is continuing his well-known work using an argon⁺ laser source by reporting data on selenious acid solutions¹⁰⁹ and upon water.¹¹⁰ The cerium(IV)-nitrate ion-water system has been studied by Miller and Irish¹¹¹ who have postulated the formation of nitratocerium complexes and also of bidentate nitrate coordination. Hester and Grossman¹¹² have examined In^{3+} ions in water and have shown evidence for the cation $\text{In}(\text{H}_2\text{O})_6^{3+}$ surrounded by an ordered cluster of water molecules.

The study of melts is another popular field of endeavor. The use of laser sources has greatly increased the versatility since color is now no problem. Thus, NaNO_3 (at 350°), HgBr_2 (at 270°), and HgI_2 (deep red)¹¹³ have been investigated in apparatus capable of operating up to 1000° . The stannous chloride melt has been shown to contain $(\text{SnCl}_2)_n$ chains with three-coordinate tin atoms unlike its lead analog which is found to contain predominantly PbCl_3^- .¹¹⁴ Very recently, mercuric iodide, which has a color and phase transition at 126° , was studied using far-infrared and laser-Raman spectroscopy. The red form (low-temperature stable) was shown to be nonmolecular, whereas the yellow species and also the melt are molecular.¹¹⁵

F. CONCLUSION

There is little doubt that the laser has contributed most to the study of the Raman spectra of inorganic compounds. The advantages may be summed up as follows: the use of red lasers and sophisticated Raman spectrometers enables us to examine deeply colored molecules either in bulk, sealed in glass ampoules, or as solutions, liquids, or powders. The study

(94) D. M. Adams and P. J. Lock, *J. Chem. Soc., A*, 145 (1967).

(95) G. C. Hayward and P. J. Hendra, *ibid.*, 643 (1967).

(96) I. R. Beattie and H. Chudzynska, *ibid.*, 984 (1967).

(97) N. N. Greenwood, B. P. Straughan, and A. E. Wilson, *J. Struct. Chem.*, in press.

(98) E. B. Bradley, M. S. Mathur, and C. A. Frenkel, *J. Chem. Phys.*, 47, 4325 (1967).

(99) P. J. Hendra and P. J. Park, *J. Chem. Soc., A*, 908 (1968).

(100) J. R. Alkins, F. Blunt, P. J. Hendra, and P. J. Park, *J. Struct. Chem.*, in press.

(101) F. Blunt, P. J. Hendra, and P. J. Park, *ibid.*, in press.

(102) P. J. Hendra and J. R. McKenzie, *Chem. Commun.*, 760 (1968).

(103) E. W. Abel, R. A. N. McLean, S. P. Tyfield, P. S. Braterman, A. P. Walker, and P. J. Hendra, *J. Chem. Soc., A*, in press.

(104) A. Davidson and J. W. Faller, *Inorg. Chem.*, 6, 845 (1967).

(105) H. D. Kaesz, R. Bau, D. Hendrickson, and J. M. Smith, *J. Amer. Chem. Soc.*, 89, 2844 (1967).

(106) C. O. Quicksall and T. G. Spiro, *Chem. Commun.*, 839 (1967).

(107) D. M. Adams, J. B. Cornell, J. L. Dawes, and R. D. W. Kemmitt, *Inorg. Nucl. Chem. Lett.*, 3, 437 (1967).

(108) I. J. Hyams and E. R. Lippincott, *Nature*, 214, 267 (1967).

(109) G. E. Walrafen, *J. Chem. Phys.*, 46, 1870 (1967).

(110) G. E. Walrafen, Symposium on Applied Spectroscopy, Chicago, Ill., 1966; *J. Chem. Phys.*, 48, 244 (1968).

(111) J. T. Miller and D. E. Irish, *Can. J. Chem.*, 45, 147 (1967).

(112) R. E. Hester and W. E. L. Grossman, *Spectrochim. Acta*, 23A, 1945 (1967).

(113) J. H. R. Clarke, C. Solomons, and K. Balasubrahmanyam, *Rev. Sci. Instrum.*, 38, 655 (1967).

(114) J. H. R. Clarke and C. Solomons, *J. Chem. Phys.*, 47, 1823 (1967); 48, 526 (1968).

(115) A. J. Melveger, R. K. Khanna, B. R. Guscott, and E. R. Lippincott, *Inorg. Chem.*, 7, 1630 (1968).

of melts and photosensitive species has also been facilitated. A scan of the first three sections above will show that no blue or green compounds have been examined successfully. This reflects the popularity of the helium-neon laser as a source. A number of deeply colored molecules absorbing in the red have, however, been studied using a low-power (~ 80 mW) argon ion laser at Southampton.¹¹⁶ These include the powdered samples of vanadyl acetylacetonate, vanadyl sulfate, and copper sulfate, which all give spectra of average quality. The first two compounds are darker blue than copper sulfate and their spectra contain an intense Raman shift of 1000 cm^{-1} which is assigned to the V-O stretching frequency. The vanadyl ion may also be studied in aqueous solution, where it has previously been inaccessible to vibrational investigations.

It is probable that in the next few years Raman spectroscopy will become accepted as the standard method of studying the vibrational spectra of inorganic and organometallic species rather than its absorption counterpart, since the high symmetry of many interesting compounds makes this new technique fundamentally more valuable.

V. Raman Spectra of Organic Compounds

A. LOW MOLECULAR WEIGHT COMPOUNDS

There are relatively few examples yet to be found in the literature of the examination of organic materials other than polymers. It is, however, now becoming clear that spectroscopists who have access to laser-Raman instruments are using them for investigations which could otherwise have been carried out with arc sources.

An early study of a deeply colored organic molecule was that of hexanitrosobenzene¹¹⁷ which was shown, using laser sources, to have structure I. A more recent example is due to

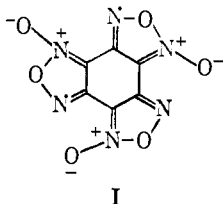

Durig and Morrissey¹¹⁸ who have studied the spectrum of the cyclic molecules 2-bromocyclobutanone and 2-bromo-2,4,4-trideuteriocyclobutanone.

During 1967 a number of other small molecules were studied including those of type $\text{XC}\equiv\text{CCN}$ ($\text{X} = \text{Cl}, \text{Br}, \text{and I}$), compounds which are colorless but too photosensitive to study with a mercury arc. All the fundamentals were observed and assigned.¹¹⁹ In another paper, data on the vibrations of protonated and deuterated methylimidazoles were given and assigned to fundamental modes,¹²⁰ while in a further paper halo-butyne were studied with a view to obtaining information on free rotation of the methyl groups.¹²¹ More recently, a very simple molecule, perdeuteriotrimethylphosphine, has been examined thoroughly using infrared (liquid and vapor),

(116) T. Gilson, private communication.

(117) N. Bacon, A. J. Boulton, and A. R. Katritzky *Trans. Faraday Soc.*, **63**, 833 (1967).

(118) J. R. Durig and A. C. Morrissey, *J. Chem. Phys.*, **47**, 4455 (1967).

(119) P. Klaboe and E. Kloster-Jensen, *Spectrochim. Acta*, **23A**, 1981 (1967).

(120) C. Perchard and A. Novak, *ibid.*, **23A**, 1953 (1967).

(121) R. D. McLachlan, *ibid.*, **23A**, 1793 (1967).

Table VII

Laser-Raman Spectra of Paraffins.^a Longitudinal Acoustical Vibration Frequencies ($\Delta\nu$, cm^{-1})

C_nH_{2n+2} n	Order of mode "m" m	$\Delta\nu$ (obsd)
18	1	132.5
	3	355
	5	493
36	1	67.4
	3	189
	5	303
	7	403
94	9	475
	1	26
	3	71
	5	121
	7	168
	.	.
	.	.
C_nD_{2n+2}	29	536
	31	556
$n = 36$	1	62.0
	3	175
	5	281

^a Results extracted from ref 124.

far-infrared, and laser-Raman data. A complete assignment has been proposed for the first time.¹²²

There have been numerous examples of the spectra of fluorescent or deeply colored organic molecules produced as proof of the effectiveness of the laser as a source by instrument companies and individuals. For example, Schröder and Stockburger showed a spectrum of the deeply colored species *p*-nitro-*p*'-dimethylaminostilbene¹²³ in 1965, while 2 years earlier Daniliheva examined 4,4'-azoxyanisole and anisal-*p*-aminoazobenzene³⁴ successfully using ruby sources.

Recently, Schaufele and Schimanouchi¹²⁴ have published details on the Raman-active low-frequency modes in a series of straight-chain paraffins. They find that in these molecules groups of lines occur close to the exciting line with a regular spacing proportional to $(\text{the chain length})^{-1}$. Applying acoustical considerations and treating the molecules as elastic rods, they show that

$$\nu = \frac{m}{2L} \left(\frac{E}{\rho} \right)^{1/2}$$

where ν = frequency of the acoustic vibration, m = order of the vibration (or the number of modes per rod), L = length of the "rod," E = Young's modulus, and ρ = density. Note m is always an *odd* number to satisfy the Raman selection rules. A selection of their data is included in Table VII, where it can be seen that there is an excellent agreement between theory and experiment. Careful analysis of the data led the authors to a value for Young's modulus of $(3.58 \pm 0.25) \times 10^{12}$ dyn/cm², a value comparable to that determined from X-ray diffraction techniques on polyethylene but far higher than the mechanical value. For a polymer with 10^5 coupled methylene groups, the acoustic modes would be separated in frequency by only 10^{-2} cm⁻¹, but the band system

(122) P. J. Hendra and P. J. Park, *ibid.*, **25A**, 2081 (1968).

(123) B. Schröder and M. Stockburger, *Naturwissenschaften*, **52**, 298 (1965).

(124) R. F. Schaufele and T. Schimanouchi, *J. Chem. Phys.*, **47**, 3005 (1967).

Table VIII

Laser-Raman Spectra of Polyethylene Fibers		
Frequency, $\Delta\nu$, cm^{-1}	Dichroic maximum ^a	Suggested assignment
2932	Equal	$B_{1g}\nu_{\text{CH}}$
2865	\perp	$A_g\nu_{\text{CH}}$
1456	\perp	...
1440	\perp	$A_g\text{CH}_2$ bend
1415	\parallel	$B_{2g}\text{CH}_2$ wag
1295	Equal	$B_{3g}\text{CH}_2$ twist
1174	\perp	$B_{1g}\text{CH}_2$ wag
1133	\parallel	B_{2g}
1065	Equal	A_g } $\nu_{\text{C-O}}$

^a \perp and \parallel refer to the orientations of the electric vector of the source relative to the fiber axis.

would occur in the region where pressure scanned Fabry-Perot interferometers are useful. The type of study described by Schaufele and Shimanouchi may well have enormous potential in the study of intermediate and high molecular weight materials.

B. POLYMERS

Two review articles have appeared in this field during 1967¹²⁵ and 1968.¹²⁶ The first description of a laser-Raman spectrum of a polymer was that of isotactic polypropylene which appeared very early in 1967.¹²⁷ Since then, spectra of polyethylene, polybutene,⁴⁵ polyoxyethylene, polyoxybutene, polyisobutylene,¹²⁵ polyvinyl chloride,¹²⁸ and others have appeared.

Using laser-Raman results on polyoxymethylene (hexagonal, orthorhombic, and perdeuterohexagonal), a full assignment has been proposed and a check between observed and calculated frequencies of vibration made possible.¹²⁸ The value of laser-Raman spectroscopy was demonstrated in that four A_1 and $3E_2$ modes (all infrared silent) have been identified in the hexagonal cases while in the orthorhombic modification four A modes have been observed for the first time. Secondly, it has been shown that, particularly at low frequencies, even the most elegant coordinate calculations are simply not accurate enough to tell us much about the vibrational characteristics of a polymer (e.g., 10% errors are common below 600 cm^{-1}).

During 1967 a new phenomenon was reported, that of dichroism in the Raman spectra of oriented stretched fibers.¹²⁹ In the first experiments isotactic polypropylene was used, but no attempt was made to interpret the results due to the complexity of the spectra. More recently, a note has been published on oriented fibers of polyethylene.¹³⁰ The data are listed in Table VIII, where it can be seen that the intensity of the lines is frequently very sensitive to the orientation of the fiber bundle relative to the electric vector of the laser. The assumption has to be made that the intensity is maximized when the

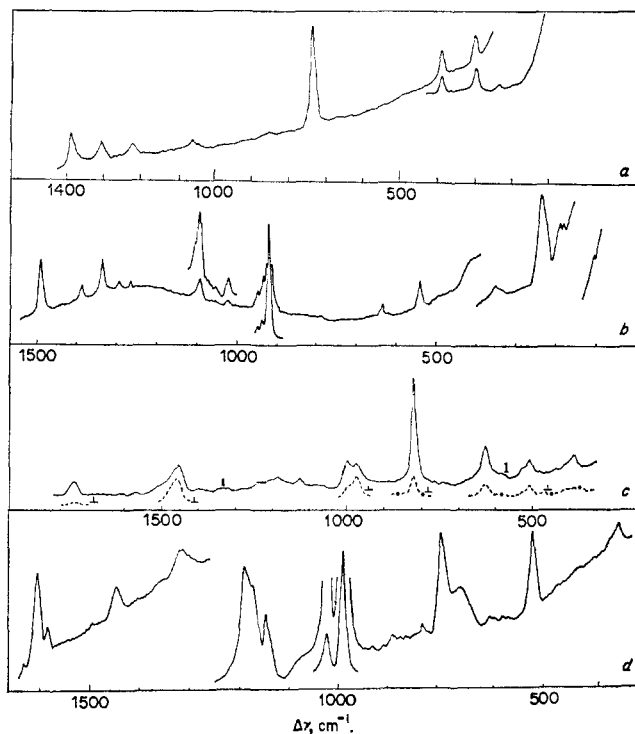

Figure 5. Raman spectra of some polymers: (a) polytetrafluoroethylene block, (b) polyoxymethylene hexagonal, (c) poly(methyl methacrylate) rod, (d) polystyrene block.

movement vectors and electric vector are parallel.^{130a} If this is so, then the previously proposed assignment of the Raman spectrum of polyethylene is in error and must be revised.^{131, 132} The new suggestions are included in Table VIII. They are much closer to some previous proposals due to Linn,¹³³ Krimm,¹³⁴ and coworkers. Recently the phenomenon has been explained thoroughly as it applies to atactic polystyrene.^{134a}

Recording Raman spectra of polymers is now extremely easy. To demonstrate the quality of spectra one can now expect, we show in Figure 5 a set of typical spectra including those of powder samples of polytetrafluoroethylene and polyoxymethylene (hexagonal), poly(methyl methacrylate) rod (including depolarization results), and polystyrene sheet ($1/16$ in. thick). In Figure 6 we show polyethylene and Nylon 66 fibers oriented parallel and perpendicular to the electric vector of the laser beam. All these spectra were recorded on a Cary 81 spectrometer and many (particularly Nylon and syndiotactic polypropylene) are being interpreted at present. With the on-axis illuminating and viewing system used on this machine, it is possible to record spectra of thin sheets of polymer with ease.

C. CHARGE-TRANSFER COMPLEXES

Infrared spectroscopy of charge-transfer complexes has become an established method of obtaining structural in-

(125) R. F. Schaufele, *Trans. N. Y. Acad. Sci.*, **30** (1967).

(126) R. F. Schaufele, *Macromol. Rev.*, **3** (1968).

(127) R. F. Schaufele, *J. Opt. Soc. Amer.*, **57**, 105 (1967).

(128) G. Zerbi and P. J. Hendra, *J. Mol. Spectrosc.*, **27**, 17 (1968).

(129) P. J. Hendra and H. A. Willis, *Chem. Ind. (London)*, 2146 (1967).

(130) P. J. Hendra and H. A. Willis, *Chem. Commun.*, 225 (1968).

(130a) The A_g class modes of polyethylene are strictly active whether the electric vector of the source be parallel or perpendicular to the fiber axis. The intensity of the line characteristic of this mode will probably be maximized in the direction of the displacement vectors, i.e., across the molecular axis.

(131) P. J. Hendra, *J. Mol. Spectrosc.*, **28**, 118 (1968).

(132) R. G. Snyder, *ibid.*, **23**, 224 (1967).

(133) T. P. Linn and J. L. Koenig, *ibid.*, **9**, 228 (1962).

(134) S. Krimm and C. G. Opasker, *Spectrochim. Acta*, **21**, 1165 (1965).

(134a) S. W. Cornell and J. L. Koenig *J. Appl. Phys.*, **39**, 4883 (1968).

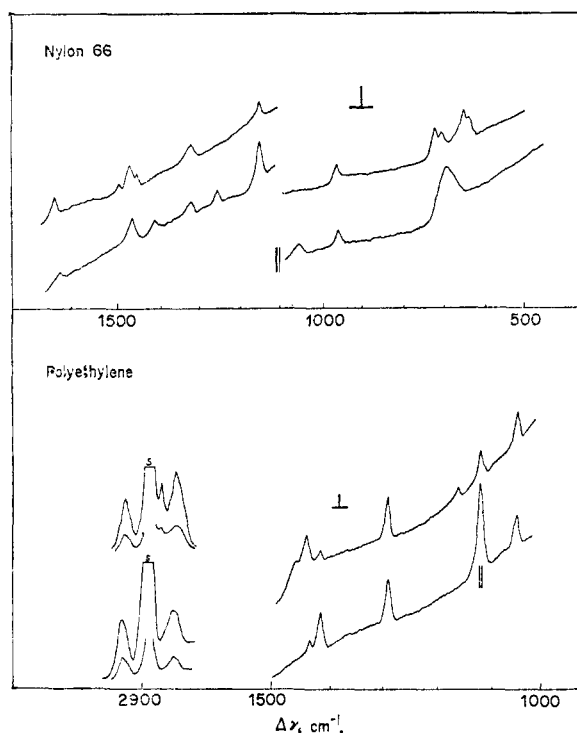
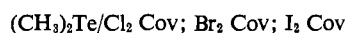
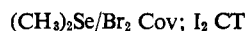
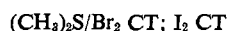

Figure 6. Oriented fiber Raman spectra of "Nylon" 66 and polyethylene: S = spurious line in spectrum; || and ⊥ relate the orientation of the electric vector to the fiber axis.

formation. Thus, during 1967, Person, a major contributor in the field, published the seventh in a series of papers on charge-transfer complexes and showed that the 1:1 bromine-benzene complex had C_{3v} symmetry.¹³⁵ Two papers have appeared on the Raman spectra of charge-transfer complexes. In the first, iodoform complexes of 1,4-diselenan, 1,4-dithian, and octasulfur were studied using laser-Raman and far-infrared techniques.¹³⁶ It was shown that, whereas at higher frequencies no shifting of bands occurred due to complex formation at low frequencies, shifting and lifting of degeneracies took place. It was not possible to identify a spectral band due to stretching of the donor-acceptor link. In the second, spectra of iodine, bromine, and iodine monochloride charge-transfer complexes in solution were described.¹³⁷ When strong interactions occur, the interhalogen stretching force constant can be halved. A Raman band at 163 cm^{-1} in the pyridine-iodine system was interpreted as due to an N-I stretching mode.

During 1966 Hayward¹³⁸ studied the spectra of the halogen (and interhalogen compounds) dimethyl chalcogenide systems. The data were compatible with the following structures



where CT indicates a charge-transfer structure and Cov an almost linear X-Y-X system ($Y = \text{S, Se, and Te}$).

(135) W. B. Person, C. F. Cook, and H. B. Friedrich, *J. Chem. Phys.*, **46**, 2521 (1967).

(136) G. C. Hayward and P. J. Hendra, *Spectrochim. Acta*, **23A**, 1937 (1967).

(137) P. Klaboe, *J. Amer. Chem. Soc.*, **89**, 3667 (1967).

(138) G. C. Hayward, Ph.D. Thesis, London, 1967, p 71.

VI. Raman Spectra of Single Crystals

A. INTRODUCTION

The investigation of crystals by Raman spectroscopy has been greatly facilitated because the source requirements are fitted by the characteristics of the laser. The narrow beam of collimated, polarized, monochromatic radiation is ideal and can be directed into small oriented crystals. Experimentally, the optical scheme of right angled illumination (Figure 2a) is used because interpretation of the results is easier. Analysis of the spectra assists in the unambiguous assignment of the internal modes of the molecules or ions and the external modes of the crystal lattice. Information can be obtained on the magnitude of the polarizability derivative ($\partial\alpha/\partial q$) from intensity measurements. Unfortunately, birefringence and optical activity of the crystal will alter the polarization character of the radiation making absolute values meaningless if careful precautions are not taken. Crystal twinning, imperfections, internal reflections, enantiomorphism, and polarization selectivity of the monochromator give rise to errors in intensity measurements. The latter problem is solved by positioning a polarization scrambler before the slit.

Molecules or ions are in ideal static positions in a crystal; thus once the structure of the lattice is known and the symmetry determined, the vibrations of the molecule and lattice may be designated by symmetry types. Raman scattering originates from those vibrations that alter the polarizability during their oscillation, and the scattering pattern (distribution of scattered light) depends on the symmetry of the interacting vibration. The illuminating direction and polarization coupled with the direction and polarization of the detected radiation are also describable in symmetry terms. Thus, with a particular symmetry arrangement of irradiation and analysis, only light originating from vibrations of this symmetry will be detected. The review by Loudon¹³⁹ contains a table listing the symmetries of Raman active modes and the polarizability derivatives associated with them. Before illustrating the above with an example, it is desirable to define a shorthand for the geometry of illuminating and scattered rays employed to obtain each spectrum. A convenient nomenclature was devised by Damen, Porto, and Tell,¹⁴⁰ and its acceptance has become widespread. In the following discussion the axes and cartesian coordinates are identical with and refer to those fixed in the crystal with the z axis parallel to the principal or optic axis. It must be remembered firstly that the magnetic and electric vectors undergo the same changes (thus only the electric vector need be described), and secondly that the electric vector is normal to the plane of polarization. [The diagrams in Figure 7 depict the radiation direction as solid-headed arrows and their electric vector as double-headed arrows.] The first diagram, 7a, shows the incident beam arriving along the x axis with its electric vector oriented in the z direction and the scattered light, received by the spectrometer, leaving with the same polarization *via* the y axis. Combining these in the same order, but grouping the electric vector orientations in parentheses, we have the shorthand $x(zz)y$. Similarly, in Figure 7b, the arrangement is $x(zx)y$. The usefulness of this nomenclature is that the parentheses contain the label for the interacting component of α' (the polarizability derivative ($\partial\alpha/\partial q$)). Therefore, the spectrum produced using the geometry $x(zx)y$

(139) R. Loudon, *Advan. Phys.*, **13**, 423 (1964).

(140) T. C. Damen, S. P. S. Porto, and B. Tell, *Phys. Rev.*, **142**, 570 (1966).

Table IX
Observed Peak Heights (Spectral Slit Width $\sim 10 \text{ cm}^{-1}$) for Raman Spectrum of $(\text{NH}_4)_2\text{PtCl}_4$ Crystals

Cm^{-1}	Crystal axes				Bond axes			
	$I_{x(y)y}z$	$I_{y(x)y}z^a$	$I_{z(y)y}z$	$I_{z(xy)z}$	$I_{x'(y'y')z'}$	$I_{y'(x'y')z'^a}$	$I_{z(y'y')z}$	$I_{z(x'y')z}$
196	7.4	1.1	7.4	4.9	2.6	3.4	5.3	7.6
306	0.3	2.3	1.8	2.8	2.8	0.9	2.2	1.5
326	10	1.1	10	6.6	10	2.6	10	6.5

^a These intensities were calibrated to give $I_{y(z)y}z = I_{x(zy)z}$ for the E_g lattice modes at 78 and 71 cm^{-1} , respectively. This information is from Beattie and Gilson.¹⁴¹

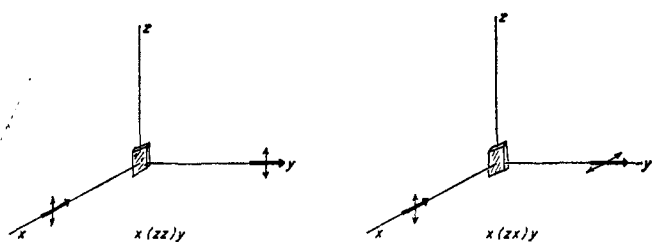

Figure 7. Illustrations of the Damen, Porto, and Tell¹⁴⁰ notation.

will indicate the magnitude of α'_{zy} for each vibration. Optics that collect a large angled cone of scattered radiation, as on the Cary 81, will also gather some radiation from α'_{zz} .

B. INTERPRETATION OF THE SPECTRUM OF $(\text{NH}_4)_2\text{PtCl}_4$

The example $(\text{NH}_4)_2\text{PtCl}_4$ is chosen because it illustrates the unambiguous assignment of the observed Raman shifts to the internal vibrations of the crystal. The results are useful to the chemist, who can, with care, transfer the assignments to the spectra of the species in liquid and gaseous phases. The ion $[\text{PtCl}_4]^{2-}$ has site symmetry D_{4h} in the crystal, and from group theoretical considerations it has three Raman-active modes, $\nu_1(a_{1g})$, $\nu_2(b_{1g})$, and $\nu_4(b_{2g})$. The flat ion lies in the xy plane of the crystal fixed axes, but the bonds bisect the angle between the x and y axes. The definition of new axes x' and y' along the bonds allows the derived polarizabilities to be written

$$\alpha'(\nu_1) = \begin{pmatrix} a & 0 & 0 \\ 0 & a & 0 \\ 0 & 0 & b \end{pmatrix} \quad \alpha'(\nu_2) = \begin{pmatrix} c & 0 & 0 \\ 0 & -c & 0 \\ 0 & 0 & 0 \end{pmatrix}$$

$$\text{and } \alpha'(\nu_4) = \begin{pmatrix} 0 & d & 0 \\ d & 0 & 0 \\ 0 & 0 & 0 \end{pmatrix}$$

which may be condensed, by simply quoting the nonzero components, into

$$a_{1g} \quad \alpha'_{x'z'} + \alpha'_{y'y'}, \quad \alpha'_{zz} \quad (\text{i.e., } \alpha'_{x'z'} = \alpha'_{y'y'} \neq \alpha'_{zz})$$

$$b_{1g} \quad \alpha'_{x'z'} - \alpha'_{y'y'} \quad (\text{i.e., } \alpha'_{x'z'} = -\alpha'_{y'y'})$$

$$b_{2g} \quad \alpha'_{x'y'}$$

The intensity of a Raman line is a function of the polarizability derivatives squared; thus the optical geometries of interest

here are those that measure light from $\alpha'_{x'z'}$ or $\alpha'_{y'y'}$, and $\alpha'_{x'y'}$, which will produce high and low intensities, respectively, from the bands of ν_1 and ν_2 , and *vice versa* for the ν_4 vibrations. The results obtained by Beattie and Gilson¹⁴¹ are given in Table IX from which it is apparent that bands at 326 and 306 cm^{-1} arise from ν_1 and ν_2 and that at 196 cm^{-1} is due to ν_4 . Returning to the crystal based axes we can confirm these conclusions and definitely ascribe the ν_1 and ν_2 vibrations to their respective frequencies. The incident and scattered radiation now travels along the x , y , and z axes. The transformation of the polarizability derivatives to the x , y , z set of axes is seen to produce the nonzero values, for the different symmetry types, as follows.

$$a_{1g} \quad \alpha'_{zz} + \alpha'_{yy}, \quad \alpha'_{zz}$$

$$b_{1g} \quad \alpha'_{xy}$$

$$b_{2g} \quad \alpha'_{zz} - \alpha'_{yy}$$

Hence, the vibrations ν_2 and ν_4 have exchanged their polarizability characteristics because of the different description. It should be remembered that the absolute values of the polarizability are indifferent to any change in our frame of reference. The vibration ν_1 has a frequency 326 cm^{-1} and ν_2 306 cm^{-1} as deduced from the values in Table IX. The spectrum of the ion $(\text{PtCl}_4)^{2-}$ has now been unambiguously assigned to the vibrations within the ion. It is comforting to note that these results confirm the suggested assignments arrived at from solution data, included in Table III. Intensities are impossible to derive theoretically to compare, in any way other than in the crudest relative manner, with the experimental values, as Table IX demonstrates. Internal reflections and imperfections in the crystal cannot be predicted and will never be repeated in any two crystals. The effects of birefringence and optical activity on the polarized radiation can be accounted for when calculating intensities.

C. APPLICATIONS

The analysis of the spectra of single crystals to assist in the unambiguous assigning of vibrational modes of molecules and complex ions is just one application of this technique. Others are exemplified by the detection of scattering from lattice modes, in single and mixed crystals, F centers, and even spin-waves. Some typical examples of the considerable

Table X

A Selection of the Crystals Investigated

Crystal	Source and detection method	Results	Ref
KH ₂ PO ₄	He-Ne 6328 Å, 20 mW, photoelectric	The assignment of the bands is reported—only a précis of a conference paper; internal and external modes assigned using symmetry arguments	142
GaP	He-Ne (a), photographic	First- and second-order (fundamental and overtone-combination bands) spectrum recorded; a tentative assignment of the second-order spectra is presented with the assigned fundamentals	143
	He-Ne, 35 mW, photographic	Frequency variations were detected at different scattering angles; polaritons are invoked in the explanation of the effect	144
GaF ₂	He-Ne (a), photographic	The first and second-order spectra agreed with the previous results; no assignment given.	145
CaWO ₄	He-Ne (a), photographic	Eleven of the expected 13 Raman-active bands were observed; polarization data indicated the symmetry of ten of these fundamentals	146
Silicon	He-Ne (a), photographic	Optical phonon energy at center of Brillouin zone was found to be $523 \pm 1 \text{ cm}^{-1}$ in excellent agreement with ir ($522 \pm 2 \text{ cm}^{-1}$) and neutron scattering ($518 \pm 8 \text{ cm}^{-1}$) data; long exposures (of 16 hr) were required	147
KD ₂ PO ₄	He-Ne, 20–80 mW	The internal and external shifts agree with those from conventional Raman and ir; the O–H–O vibrations identified at 985 and 1295 cm^{-1} appearing in the spectra of mixtures $x = D/(H + D) = 0.8$ and 0, respectively, are not assigned; D is the concn of KD ₂ PO ₄ and H that of KH ₂ PO ₄	148
F centers in NaCl and KCl	He-Ne 6328 Å, Ar ⁺ 5145 and 4880 Å, photoelectric	The resonance Raman effect was exploited in NaCl and KCl when the Ar ⁺ laser was used; the NaCl spectrum was assigned but the KCl was not sufficiently resolved for a definite assignment	149
ZnO	Ar ⁺ 5145 and 4880 Å, 50 mW, photoelectric	Assignment of first-order spectrum is different from previous suggestions; extensive use of polarization and orientations of the crystal	140
		Polariton scattering observed as a frequency variation with observational directions close to the forward direction	150
CdS	Ar ⁺ 5145 Å (at liq N ₂ temp), He-Ne 6328 Å (used to detect low frequency mode), photoelectric	The assignment of all the fundamentals differs from previous Raman studies; polarization data was obtained to strengthen the allocation of vibrations to the observed frequency shifts	151
	Ar ⁺ laser, photoelectric	A study of the resonance Raman effect; the spectrum arising from the argon lines at 5145, 4965, 4880, and 4765 Å caused an enhancement of the Stokes intensities when the source frequency was near that of an absorption band	152
Calcite	He-Ne, 50 mW, photoelectric	Anomalous results, obtained previously from measurements on the polarization of the A _{1g} mode, were not detected	153
	He-Ne, 150 mW, photoelectric	The A _{1g} Raman line width increases with temperature; confirmed by a decrease in threshold power for the stimulated Raman effect as the temperature was lowered; very narrow line width of 1.1 cm^{-1} at 300°K	154
YPO ₄ + YbPO ₄	He-Ne, 20 mW, photoelectric	Not a full spectrum; only 7 out of the 12 active Raman bands found above 275 cm^{-1} ; no polarization measurements made on weaker bands	155
FeF ₂ + MnF ₂	Ar ⁺ 4880 Å, 50 mW, photoelectric	First- and second-order interactions are observed between photons and magnons; there is a big discrepancy in intensities, but the frequencies and temperature dependencies agree with the antiferromagnetic resonance values	156
Mixed crystals CaF ₂ + SrF ₂ , and also SrF ₂ + BaF ₂	He-Ne photoelectric (a multichannel analyzer recorded the spectra pictorially)	The first-order spectrum indicated a homogeneous crystal formed by solid solutions of the two components	157
LiNbO ₃	He-Ne, ~85 mW, photoelectric	No full assignment as only 3 of the 5 A ₁ and 7 of the 10 E modes were unequivocally allocated frequencies; another E vibration was tentatively ascribed a frequency; a few other bands remained unassigned because of ambiguities	158
K ₃ [Fe(CN) ₆]	He-Ne, 50 mW, photoelectric	Near complete assignment—only the ν_{10} $\delta(\text{Fe-C-N})$ unobserved of the internal modes; the assignment of the external modes was made assuming a C _{2h} ⁵ symmetry	159

Table X (Continued)

Crystal	Source and detection method	Results	Ref
<i>trans</i> -[PtBr ₂ (SMe ₂) ₂]	He-Ne 50 mW, photoelectric	The assignment of three of the internal modes indicates the usefulness of oriented crystal studies even with large molecules of low symmetry	160
Mixed crystals Ge and Si	Ar ⁺ 4880 Å, photoelectric	The observed bands due to Ge and Si show that there is no mixing and site sharing; a change in the frequency of the Si line is explained as a local mode association with an isolated Si atom or nearest neighbor	161
TiO ₂ , MgF ₂ , ZnF ₂ , FeF ₂ , and MnF ₂	Ar ⁺ 4880 Å, 75 mW, photoelectric	A full allocation of the fundamental vibrations of symmetry type A _{1g} , B _{1g} , B _{2g} , and E _g ; polarization used in assigning the bands; the results all indicate symmetry D _{4h}	162
CaWO ₄ , SrWO ₄ , CaMoO ₄ , SrMoO ₄	Ar ⁺ 4880 + 5145 Å, photoelectric	The bands were assigned to vibrations of both the internal and external type	163
Corundum	Ar ⁺ , photoelectric	All predicted lines were observed and assigned to internal and external vibrations	164
SrTiO ₃	He-Ne, photoelectric	New 2-phonon transitions observed and the fundamentals detected, at low temperatures, for the first time; no detailed polarization measurements made.	165
		An enhancement of Raman scattering occurred on the application of an electric field at liquid nitrogen temperature	166
Fluorides of the rare earths La, Ce, Pr, Nd	Ar ⁺ 4880 + 5145 Å, ~100 mW, photoelectric	From an investigation of different orientations of the crystal and polarization of the incident and detected radiation, a symmetry of D _{3d} ⁴ was ascribed to the crystal lattice as distinct from D _{6h} ⁴ and D _{6h} ³ previously proposed	167
α-Quartz	Ar ⁺ 4880 Å, 80 mW, photoelectric	Fundamentals were detected and allocated symmetry species using polarization measurements at different orientations	168
	Ar ⁺ 4880 + 5145 Å, 200 mW, photoelectric	Polariton Raman scattering was detected for a number of bands	169
BaTiO ₃	Source not given, photoelectric	Assignment not certain but given strength by polarization results	170
	He-Ne, 35 mW, photoelectric	Further polarization studies made on 90° and backward scattering light confirms the A ₁ and E assignments of the previous paper and allocates three more A ₁ longitudinal modes to observed frequency shifts	171
MnF ₂	Ar ⁺ 4880 Å, 50 mW, photoelectric	The second-order photon-magnon interactions are detected and interpreted theoretically; not all the features correlate with theory	172

^a The power was 30 mW from a Spectra-Physics 116 He-Ne laser.

volume of work in this subject are included in Table X.¹⁴²⁻¹⁷²

- (142) I. P. Kaminow, R. C. C. Leite, and S. P. S. Porto, *Bull. Amer. Phys. Soc.*, **9**, 660 (1964).
 (143) M. V. Hobden and J. P. Russell, *Phys. Lett.*, **13**, 39 (1964).
 (144) C. H. Henry and J. J. Hopfield, *Phys. Rev. Lett.*, **15**, 964 (1965).
 (145) J. P. Russell, *Proc. Phys. Soc.*, **85**, 194 (1965).
 (146) J. P. Russell and R. Loudon, *ibid.*, **85**, 1029 (1965).
 (147) J. P. Russell, *Appl. Phys. Lett.*, **6**, 223 (1965).
 (148) I. P. Kaminow, R. C. C. Leite, and S. P. S. Porto, *J. Phys. Chem. Solids*, **26**, 2085 (1965).
 (149) J. M. Wentock and S. P. S. Porto, *Phys. Rev. Lett.*, **15**, 697 (1965).
 (150) S. P. S. Porto, B. Tell, and T. C. Damen, *ibid.*, **16**, 450 (1966).
 (151) B. Tell, T. C. Damen, and S. P. S. Porto, *Phys. Rev.*, **144**, 771 (1966).
 (152) R. C. C. Leite and S. P. S. Porto, *Phys. Rev. Lett.*, **17**, 10 (1966).
 (153) S. P. S. Porto, J. A. Giordmaine, and T. C. Damen, *Phys. Rev.*, **147**, 608 (1966).
 (154) K. Park, *Phys. Lett.*, **22**, 39 (1966).
 (155) I. Richman, *J. Opt. Soc. Amer.*, **56**, 1589 (1966).
 (156) P. A. Fleury, S. P. S. Porto, L. E. Cheesman, and H. T. Guggenheim, *Phys. Rev. Lett.*, **17**, 84 (1966).
 (157) R. K. Chang, B. Lacin, and P. S. Pershan, *ibid.*, **17**, 755 (1966).
 (158) R. F. Schaufele and M. J. Weber, *Phys. Rev.*, **152**, 705 (1966).
 (159) J. Deveze and M. Krauzman, *C. R. Acad. Sci., Paris*, **263B**, 864 (1966).
 (160) P. J. Hendra and E. R. Lippincott, *Nature*, **212**, 1448 (1966).
 (161) D. W. Feldman, M. Ashkin, and J. H. Parker, *Phys. Rev. Lett.*, **17**, 1209 (1966).
 (162) S. P. S. Porto, P. A. Fleury, and T. C. Damen, *Phys. Rev.*, **154**, 522 (1967).
 (163) S. P. S. Porto and J. F. Scott, *ibid.*, **157**, 716 (1967).
 (164) S. P. S. Porto and R. S. Krishnan, *J. Chem. Phys.*, **47**, 1009 (1967).

There are a few terms appearing in the table that need defining. The word "phonon" is a label given to the energies, present in condensed phases, that are associated with lattice vibrations. Phonons are in constant equilibrium with the transitions between the lattice vibrational levels. A transition of one spin in an ordered array of spins in ferro- and antiferromagnetic substances may traverse the crystal, and this phenomenon is best described as a spin-wave. This has led to the introduction of the "magnon," which is the quantum of energy that is associated with spin-waves. The polariton is less easily defined. The scattered light from some vibrations alters in frequency with the angle it makes with the illuminating direction. The smaller this angle, the lower the frequency and intensity of the scattered light become. This effect indicates a deficiency in the theory of photon-phonon interaction and a new form of energy, a "polariton," is introduced into the interpretation of the results.

- (165) R. F. Schaufele and M. J. Weber, *ibid.*, **46**, 2859 (1967).
 (166) R. F. Schaufele, M. J. Weber, and B. D. Silverman, *Phys. Lett.*, **26**, 47 (1967).
 (167) R. P. Bauman and S. P. S. Porto, *Phys. Rev.*, **161**, 842 (1967).
 (168) J. F. Scott and S. P. S. Porto, *ibid.*, **161**, 903 (1967).
 (169) J. F. Scott, L. E. Chessman, and S. P. S. Porto, *ibid.*, **162**, 834 (1967).
 (170) J. L. Parsons and L. Rimai, *Solid State Commun.*, **5**, 423 (1967).
 (171) A. Pinczuk, W. Taylor, E. Burstein, and I. Lefkowitz, *ibid.*, **5**, 429 (1967).
 (172) P. A. Fleury, S. P. S. Porto, and R. Loudon, *Phys. Rev. Lett.*, **18**, 658 (1967).

VII. Miscellaneous Effects

A. ADSORBED SPECIES

During 1967 and early in 1968 reports appeared on the laser-Raman spectra of adsorbed species which have created a deal of interest in chemical industry. The experiments had been preceded by a successful investigation of thin films using the on-axis viewing system of the Cary 81 spectrometer. Bands characteristic of selenium had been found on examining a plate of quartz with a thin film of selenium coated onto its front face. No characteristics of the quartz were in evidence. A logical extension was therefore to examine surface adsorbed layers carried on gels, catalysts, and metals.

In the first paper to appear,¹⁷³ spectra were given of bromine, carbon tetrachloride, carbon disulfide, and *trans*-dichloroethylene upon chromatographic grade silica gel. A number of points were noteworthy. (a) The spectra produced were almost identical with those of the adsorbate in the liquid phase even when the surface coverages were known to be low. (b) Under favorable circumstances (*e.g.*, Br₂ on SiO₂), a band characteristic of the adsorbate could be found at very low coverages indeed (probably down to $\sim 1/10$ monolayers). (c) The spectrum of the adsorbent was almost completely absent; thus no obscuration of the adsorbate spectrum occurred.

It was demonstrated in this paper that the spectrum was that due to the adsorbed layer and not that of the vapor or another desorbed phase. The spectra of the systems, clean silica and clean silica exposed to 2 atm of nitrogen, were compared, and since no band characteristic of the ν_{N-N} mode was observed in the spectrum of the latter, it is most unlikely that the bands found in the previous experiments are due to vapor above the adsorbing surface. It would therefore seem that we have a sensitive method of studying surfaces where large parts of the spectrum are not obscured by the substrate as is so prevalent in the infrared. For examples of this problem, Little¹⁷⁴ or Hair's¹⁷⁵ books may be consulted. Turning now to the first point made above, it would have been expected that slight frequency shifts would have occurred on adsorption, and also, because of a net reduction in symmetry of the adsorbing molecule, one would expect a number of the Raman silent (infrared active) modes in a centrosymmetric system to appear. That this does not occur requires some comment. It is intuitively acceptable that the introduction of slight asymmetry into an otherwise symmetric system should induce some dipole and therefore probably a finite value of $(\partial\mu/\partial q)$, whereas it is by no means apparent that an appreciable value of $(\partial\alpha/\partial q)$ will be induced. That this is not too unreasonable is exemplified by some of the erroneous structural determinations which have appeared recently using vibrational spectroscopy. In these, pseudo-linear or near-planar pyramidal molecules the selection rules for linear and planar (D_{3h}) species seem to apply.

In the second paper¹⁷⁶ to appear in this field, experiments upon acetaldehyde adsorbed on silica gel were described. The Raman spectrum of the adsorbed layer was that of par-aldehyde (the cyclic trimer), and it is therefore suggested that the structure of the surface layer is II rather than a chemi-

sorbed species such as III. Since a complete spectrum of par-

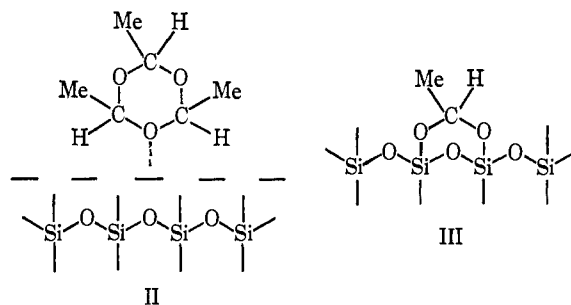

aldehyde at frequencies below 1500 cm⁻¹ was observed, there can be little doubt about this conclusion. From infrared study the evidence would be somewhat ambiguous because substrate obscuration of the spectrum between 1400 and 500 cm⁻¹ would inundate most of the spectral information.

More recently, it has been shown that it is possible to obtain good spectra from pyridine, methylamine, acetonitrile, some hydrocarbons, many halogenated species among others, absorbed on silica gel (chromatographic grade), Cab-o-sil, carbon block, and "Alon C" surfaces. There seems every likelihood that it will be possible to study species adsorbed on industrially important catalysts (of the mixed oxide or supported metal type). A further fascinating possibility is the investigation of catalysts while operating in flow systems under elevated temperatures and industrially important conditions. Unfortunately, there seems, at present, to be only one group working in this very exciting field, and further it is as yet not known whether on-axis excitation of the spectra is essential. Initial experiments using argon⁺ lasers (at 4880 Å) have shown great advantages over the helium-neon laser (6328 Å). This is not surprising since photomultiplier sensitivity is much greater in the green than in the red.

B. INTENSITIES OF RAMAN LINES

One would have expected that in this field the laser would have immediately become preeminent since unlike the discharge lamp it is relatively easy to measure the amount of light illuminating the sample and therefore to estimate absolute Raman intensities. That this is not the case simply reflects the difficulty in measuring the strength of the scattered radiation. There are reports, however, of relative intensity measurements and also of depolarization ratio evaluations. Considering the latter first, in cubic molecules the totally symmetric stretching modes should theoretically have a depolarization ratio of zero. Although low values have been obtained, they have always significantly exceeded zero. The laser, with its high purity of polarization, parallel propagation, and low emission away from the exciting line is potentially an excellent source.¹⁷⁷ Recently, Murphy, Evans, and Bender have measured the depolarization ratios for carbon tetrachloride¹⁷⁸ and obtained 0.751 ± 0.005 for $\Delta\nu = 314$ cm⁻¹ and 0.758 ± 0.006 for $\Delta\nu = 216$ cm⁻¹, in excellent agreement with the theoretical value of $3/4$. For the ν_1 vibration line at $\Delta\nu = 459$ cm⁻¹, the value was 0.0039 ± 0.0002 . The nonzero value is not caused by hot bands or an isotope effect but results from intermolecular interactions. This was nicely demonstrated by studying solutions of CCl₄ in CS₂, C₆H₆, C₆H₁₂, CH₃CN, etc.

(173) P. J. Hendra and E. J. Loader, *Nature*, 216, 789 (1967).

(174) L. H. Little, "Infrared Spectra of Adsorbed Species," Academic Press, London, 1967.

(175) M. L. Hair, "Infrared Spectroscopy in Surface Chemistry," Marcel Dekker, Inc., New York, N. Y., 1967.

(176) P. J. Hendra and E. J. Loader, *Nature*, 217, 637 (1968).

(177) A. F. Slomba, C. D. Hinman, and E. H. Siegler, Proceedings of the Conference on Analytical Chemistry and Applied Spectroscopy, Pittsburgh, Pa., 1965.

(178) W. F. Murphy, M. V. Evans, and P. Bender, *J. Chem. Phys.*, 47, 1836 (1967).

In some solvents the depolarization ratio is slightly concentration dependent and is usually higher than it is for the pure tetrachloride. In a polar solvent like CS_2 the effect is clearly shown: CCl_4 , $\rho_s = 39 \times 10^{-4}$; CCl_4 , (75%) + CS_2 , $\rho_s = 55 \times 10^{-4}$; and CCl_4 (25%) + CS_2 , $\rho_s = 72 \times 10^{-4}$.

For an example of relative intensity measurements, a series of hexacarbonyl transition element molecules and ions $\text{Re}(\text{CO})_6^-$, $\text{Mo}(\text{CO})_6$, $\text{W}(\text{CO})_6$, $\text{Cr}(\text{CO})_6$, and $\text{V}(\text{CO})_6^+$ were studied, and the ratio of the bands due to the two symmetric modes ν_1 and ν_2 was measured and interpreted in terms of π bonding in the metal-carbon bond.¹⁷⁹ It was shown by this independent method that the bond order of the M-C bands falls in the order $\text{Re} > \text{Mo} > \text{W} > \text{Cr}$ ($\text{V}(\text{CO})_6^+$ probably very low), in agreement with previous force-constant data. Photosensitivity would have made some of the required measurements impossible without access to a red source.

One of the standard techniques for measuring band intensities and thus values of the polarizability derivative ($\partial\alpha/\partial q$) has been to use an internal standard.

Molecular interactions, however, severely perturb the intensity of Raman lines (e.g., the difference in intensity of the Raman lines of vapor and liquid samples of the same molecular species¹⁸⁰), and therefore one can anticipate that the "internal standard" may not be a standard at all. The development of a new technique using some sort of convenient external standardization is obviously of importance for both these absolute measurements and also for routine quantitative analysis.

C. NONLINEAR EFFECTS

This article has been concerned so far with the applications of spontaneous incoherent scattering from molecules. The Raman effect is postulated as being the random emission of light from a virtual level, which has been populated by an incident beam of monochromatic radiation. The emission process can basically be reduced to a two-level system with a high-energy level, which occupies a nonabsorbing position in the sample's spectrum, and the ground state. Applying the arguments Einstein used to explain the radiation density of a black body, two stimulated Raman effects must be envisaged: one associated with absorption and the other with "stimulated emission," as observed in first-order energy exchanges. Both these effects have been detected, and a brief account will be given of each. Neither effect has as yet been exploited, in its own right, to answer chemical problems, but the resultant energy has found applications as a source of radiation. The whole field has recently been reviewed by Schrötter.¹⁸¹

1. Stimulated Raman Scattering

This process is generated by irradiating a sample with the intense emission from a giant pulse laser. Strong emission is found at $\nu_0 \pm n\nu_p$, where n is an integer and ν_p is the frequency of a polarized line in the normal Raman spectrum. In some samples two values of ν_p may become involved in the process, when lines will appear at $\nu_0 \pm n\nu_{p1}$, $\nu_0 \pm n\nu_{p2}$, and $\nu_0 \pm (n_1\nu_{p1} - n_2\nu_{p2})$.¹⁸²

The scattered radiation possesses all the features of laser emission; thus the line width of the emitted light is narrow

and high gains are observed while the collimation of the beam indicates its coherence. The effect is detectable either inside or outside the laser cavity. The intensity of the incident beam must reach a threshold value before stimulated Raman scattering occurs. This is another characteristic that likens it to the laser. At and above the threshold, the Stokes or anti-Stokes scattering is amplified as it passes through the cell, when up to 50% of the laser energy may be converted into the Raman frequencies. The theory of these processes has been discussed by Buckingham.¹⁸³

All three phases¹⁸⁴⁻¹⁸⁶ of matter have been stimulated in this fashion. The effect has helped to increase the number of laser emissions and enables one to change the wavelength of a laser in the region of the parent frequency. This source is called a "Raman laser" and finds chemical application in fluorescence studies. The high intensity of the light beam has enabled double¹⁸⁷ and even treble¹⁸⁸ photon fluorescences to occur. It is possible to obtain previously inaccessible information on excited states, such as lifetime, Einstein coefficients, and the structures of the excited molecules *via* these fluorescence techniques.

The vibrational lifetime of H_2 has been measured¹⁸⁹ by using the stimulated Raman effect to populate the fundamental vibrational level. Recording the intensity of the anti-Stokes line in the normal Raman effect gave a measure of the population.

Anomalous scattering arises when the cell is external to the laser cavity with the beam focused within the sample.¹⁹⁰ The amplified Stokes and anti-Stokes radiations are scattered in cones, which are concentric about the beam direction. In the forward direction the gain is highest although backward intensity is detectable.

2. Raman Absorption

This effect is also referred to as the inverse Raman effect and "Stoicheff absorption." A molecule is subjected to a high-intensity continuum in a window in its absorption spectrum. A monochromatic beam of high intensity is injected into the irradiated sample and induces absorption of the continuum. The monochromatic light stimulates Raman emission from the virtual level, while the continuum supplies energy to restore the population of this level. The effect was first observed¹⁹¹ for the benzene anti-Stokes line at 992 cm^{-1} . The radiation from a Raman laser, which had a continuum produced in a nitrobenzene cell and the parent laser emission from a ruby crystal, was focused into a benzene sample and the radiation scattered through 90° was analyzed. Later, a more thorough investigation was made,¹⁹² but the lack of intense continua has forced the possible applications to await their development. However, an absorption due to the stretching vibration of $\text{C}\equiv\text{N}$ was observed within the band envelope

(183) A. D. Buckingham, *J. Chem. Phys.*, **43**, 25 (1965).

(184) Solids: G. E. Eckhardt, D. P. Bortfeld, and M. Geller, *Appl. Phys. Lett.*, **3**, 137 (1963).

(185) Liquids: G. E. Eckhardt, R. W. Hellworth, E. J. McClung, S. E. Schwarz, D. Weiner, and E. J. Woodbury, *Phys. Rev. Lett.*, **9**, 455 (1962).

(186) Gases: R. W. Mirch, R. W. Terhune, and W. G. Rado, *Appl. Phys. Lett.*, **3**, 181 (1963).

(187) S. Singh, W. J. Jones, W. Siebrand, B. P. Stoicheff, and W. G. Schneider, *J. Chem. Phys.*, **42**, 330 (1965).

(188) S. Singh and L. J. Bradley, *Phys. Rev. Lett.*, **12**, 612 (1964).

(189) F. DeMartini and J. Ducuing, *ibid.*, **17**, 117 (1966).

(190) P. D. Maker and R. W. Terhune, *Phys. Rev.*, **137A**, 801 (1965).

(191) B. P. Stoicheff, *Phys. Lett.*, **7**, 189 (1963).

(192) W. J. Jones and B. P. Stoicheff, *Phys. Rev. Lett.*, **13**, 657 (1964).

(179) P. J. Hendra and M. M. Qurashi, *J. Chem. Soc., A*, 2963 (1968).

(180) R. E. Hester, ref 1, p 133.

(181) W. H. Schrötter, *Naturwissenschaften*, **54**, 607 (1967).

(182) E. R. Lippincott, C. Meyers, and P. J. Hendra, *Spectrochim. Acta*, **22A**, 1493 (1966).

of the C-H vibration in the stimulated Raman spectra of acetonitrile.¹⁹³

The technique has great potential in chemistry because the absorption is not restricted to the totally symmetric modes, as a complete Raman spectrum is produced, and is unaffected by fluorescence, unlike the normal Raman effect. Furthermore, there is the possibility of studying short-lived species, such as free radicals and reaction intermediates, using a high-speed absorption Raman technique, since the process can be completed in 5×10^{-8} sec.

3. Hyper-Raman Effect

Another nonlinear effect of great interest which has been reported recently is the hyper-Raman effect.¹⁹⁴ In the experiment, a specimen is irradiated with a monochromatic source of frequency ν_0 , and a very weak spectrum, produced at $2\nu_0 \pm \nu'$, is observed, where ν' is a separation of energy levels in the sample. The spectrum originates from the small but finite value of the hyperpolarizability, β , in the polarization equation

$$P = \alpha E + \frac{1}{2}\beta E^2 + \frac{1}{6}\gamma E^3 + \dots$$

where P = the induced polarization, E = the incident electric vector, α = the polarizability, β = the hyperpolarizability, and $\alpha > \beta > \gamma$, etc.

The theory of the effect has been discussed by Cyvin, Rausch, and Decius¹⁹⁵ in 1964, and the selection rules have been applied to vibrational modes of a number of molecular geometries. The first successful experiment to demonstrate the effect was completed the following year.¹⁹⁴

The hyper-Raman selection rules include all those of infrared absorption, but the number of Raman active transitions encompassed depends on the symmetry of the molecule. As far as vibrations are concerned, some modes silent in both infrared and Raman appear in a hyper-Raman spectrum, and all active modes in centrosymmetric molecules are of the ungerade type, similar to those in absorption. Here again we see that the selection rules are more extensive as the order of the effect is increased; hyper-Raman scattering is a third-order effect compared to the second-order effect of Raman scattering and the first-order of absorption. The first pure rotational spectrum of a spherical top molecule was observed by Maker,¹⁹⁶ who studied methane. It is impossible to detect either an absorption or Raman spectrum originating from pure rotational transitions in a molecule of this symmetry.

D. ELECTRONIC RAMAN SPECTRA

Fundamentally, there is no reason why Raman lines arising from electronic transitions should not be observed in suitable systems. Species with low-lying electronic levels should obviously present the least stringent experimental limitations, and so work has been concerned to date with the rare earth ions. Electric dipole transitions are not normally permitted

for the rare earth ions unless they are trapped in a lattice which exerts a crystal field capable of introducing a small degree of nonparity into the electronic transitions. On the other hand, Raman transitions are allowed between states of the same parity, and consequently this technique has promise. In 1963 and 1966 Hougén and Singh¹⁹⁷ and Chau¹⁹⁸ had obtained Raman spectra of the Pr^{3+} (using Hg 2536 Å as a source) and the Ce^{3+} ion (Hg 4358 Å), respectively. Absorption problems severely restricted the application of the technique until Königstein applied the helium-neon laser to the problem in 1966,¹⁹⁹ when he produced spectra of Eu^{3+} in yttrium aluminum garnet.

The electronic Raman effect is weak, and resonance Raman enhancement of intensity does not occur. Further, the spectrum is heavily contaminated with fluorescence lines and bands due to lattice modes. By comparing spectra to the Stokes and anti-Stokes sides of the exciting line, the fluorescent lines can sometimes be eliminated. By recording spectra at reduced temperatures (down to 4.2°K) and by observing the polarization of the lines, it is possible to distinguish the electronic Raman lines; e.g., in Nd^{3+} in yttrium gallium garnet at $\Delta\nu = 86 \text{ cm}^{-1}$ there occurs a line due to such a transition.²⁰⁰

In a more recent paper, Königstein and Mortensen²⁰¹ moved away from garnets and studied Eu^{3+} in YVO_4 and found a line at 404.5 cm^{-1} not found in Nd^{3+} in the same matrix and not due to fluorescence. The polarization behavior of this line clearly shows it to have E character, while weak lines of unknown symmetry have been reported at 359 cm^{-1} and between 950 and 1075 cm^{-1} .

Brecker, *et al.*,²⁰² have recently studied the same system and improved upon the assignment $\{^7F_1 A_2 = 333.7, E = 375.6; ^7F_2 A_1 = 985.4, B_1 = 1116.1, B_2 = 936.4, \text{ and } E = 1038.7 \text{ cm}^{-1}\}$. Königstein and Mortensen²⁰³ have reinvestigated the system and obtained new results significantly different from those of Brecker. The differences are under discussion.

Clearly, we have here a very powerful tool for obtaining information on low-lying electronic levels. The theory is under active discussion.²⁰⁴ No doubt the data and the interpretations will be of value in the development of rare earth condensed-phase lasers.

VIII. Conclusion

Raman spectroscopy has made such progress, with the laser source, that it has recently returned to the forefront of the methods for investigating molecular vibrations and rotations. The versatility of the normal Raman technique has reached that of infrared absorption and has made it possible to obtain results with the same speed and convenience. A relatively limited number of samples had been studied previously with discharge lamps, so the laser source has, effectively, expanded the field and produced results more reliable and, in some cases, more extensive than previously. In addition, a number of new nonlinear effects have been demonstrated, but their true potential in chemistry is still to be realized.

(193) J. A. Duardo, F. M. Johnson, and M. A. El-Sayed, *Phys. Lett.*, **21**, 168 (1966).

(194) R. W. Terhune, P. D. Maker, and C. M. Savage, *Phys. Rev. Lett.*, **14**, 681 (1965).

(195) S. J. Cyvin, J. E. Rausch, and J. C. Decius, *J. Chem. Phys.*, **43**, 4083 (1964).

(196) P. D. Maker, "Physics of Quantum Electronics," P. L. Kelly, *et al.*, Ed., McGraw-Hill Book Co., Inc., New York, N. Y., 1966, p 60.

(197) J. T. Hougén and S. Singh, *Phys. Rev. Lett.*, **10**, 406 (1963).

(198) J. J. H. Chau, *J. Chem. Phys.*, **44**, 1708 (1966).

(199) J. A. Königstein, *J. Opt. Soc. Amer.*, **56**, 1402 (1966).

(200) J. A. Königstein, *J. Chem. Phys.*, **46**, 2811 (1967).

(201) J. A. Königstein and O. S. Mortensen, *Phys. Rev. Lett.*, **18**, 831 (1967).

(202) C. Brecker, H. Samelson, A. Lempicki, R. Riley, and T. Peters, *Phys. Rev.*, **155**, 178 (1967).

(203) J. A. Königstein, private communication.

(204) O. S. Mortensen and J. A. Königstein, *Chem. Phys. Lett.*, **1**, 409 (1967).