

Volume 69, Number 4 August 1969

MECHANISM IN CARBOHYDRATE CHEMISTRY

BRIAN CAPON

*Chemistry Department, The University, Leicester, England**

Received April 8, 1968

Contents

I. Introduction	407	XIII. Anomerization and Dissociation of Aldose Acetates	467
II. Acid-Catalyzed Hydrolysis of Glycopyranosides	415	XIV. Nucleophilic Displacement Reactions at Positions Other Than C(1) of Aldose Derivatives	469
A. Intermolecular Catalysis	415	XV. Oxidation of Aldoses with Bromine	493
B. Intramolecular Catalysis	425	XVI. Reactions of Aldonic Acids and Their Derivatives	496
III. Acid-Catalyzed Hydrolysis of Glycofuranosides	427		
A. Aldofuranosides	427		
B. Ketofuranosides	429		
IV. Alkaline Fission of Glycosides	429		
V. Enzymically Catalyzed Hydrolysis of Glycosides	433		
A. Introduction	433		
B. Lysozyme	434		
C. Amylases and Glucamylases	437		
D. Almond Emulsin β -Glucosidase	439		
E. β -Galactosidases	439		
VI. Fischer Glycoside Synthesis	440		
A. Initial Reaction	440		
B. Anomerization of Furanosides	440		
C. Ring Expansion of Furanosides to Pyranosides	441		
D. Anomerization of Pyranosides	443		
E. Conclusion	443		
VII. Ring-Closure Reactions of Aldose Acetals	443		
VIII. Formation, Rearrangement, and Hydrolysis of Cyclic Acetals and Ketals	445		
A. Formation and Rearrangement	445		
B. Hydrolysis	446		
IX. Hydrolysis of Glycosylamines and Nucleosides	448		
A. Glycosylamines Derived from Primary Amines	448		
B. Glycosylamines Derived from Secondary Amines	449		
C. Nucleosides	449		
X. Mutarotation of Aldoses and Ketoses	454		
A. Simple Mutarotations	454		
B. Complex Mutarotations	456		
XI. Reactions of Aldoses with Carbonyl Reagents	458		
A. Oxime, Semicarbazone, and Phenylhydrazone Formation	458		
B. Osazone Formation	460		
XII. Nucleophilic Displacement, Anomerization, and Elimination Reactions of Glycosyl Halides	462		
A. Nucleophilic Displacements	462		
B. Anomerization	466		
C. Elimination Reactions	467		

I. Introduction

Carbohydrates possess a higher density of functional groups than any other class of compounds. Interactions between these groups and competing reactions between different groups occur frequently; hence this is a rich field for the study of complex reaction mechanisms, and it is the purpose of this review to record progress that has been made.

The most widely investigated class of carbohydrates is the aldoses, which, although formally polyhydroxyaldehydes, usually exist as internal hemiacetals. The most reactive center in these compounds and their derivatives is at C(1), and most sections of this review are concerned with reactions at this center. Pyranose forms are generally the most stable and their conformational analysis has received considerable attention (see ref 1). The pyranose ring resembles the cyclohexane ring, but there is some additional distortion from a perfect chair because the carbon-oxygen bond is about 10% shorter than the carbon-carbon bond (see Table II of ref 2). Also dipolar effects are important in determining the relative stabilities of axially and equatorially substituted derivatives at C(1). Angyal has calculated the interaction energies for the chair conformations of the hexoses and pentoses, and on the basis of these calculations the most stable conformations would be expected to be those shown in Scheme I.¹ In this scheme when the difference in energies of the normal and alternative conformations are calculated to be more than 2 kcal mole⁻¹, only the more stable is shown, but when it is less than this both are given.

* Present address: Chemistry Department, University of Glasgow, Glasgow W.2, Scotland.

(1) (a) E. L. Eliel, N. L. Allinger, S. J. Angyal, and G. A. Morrison, "Conformational Analysis," Interscience Publishers, New York, N. Y., 1965, Chapter 6; see also P. R. Sundarajan and V. S. R. Rao, *Tetrahedron*, **24**, 289 (1968); (b) S. J. Angyal, *Aust. J. Chem.*, **21**, 2737 (1968); *Angew. Chem. Intern. Ed. Engl.*, **8**, 157 (1969).

(2) G. A. Jeffrey and R. D. Rosenstein, *Advan. Carbohydr. Chem.*, **19**, 7 (1964).

Scheme 1
Conformations of the Aldopyranoses^a

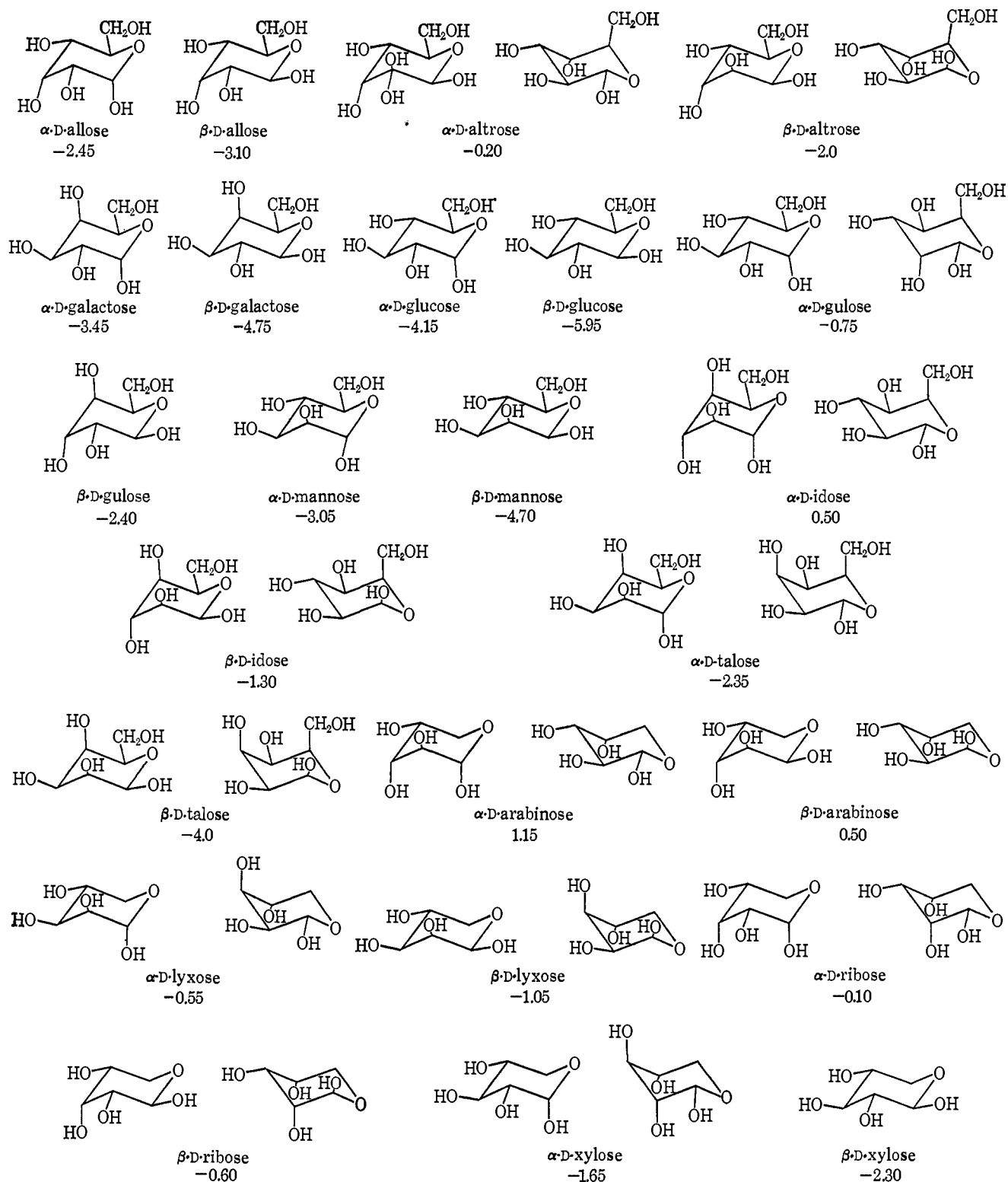

^a The numbers are the differences in the calculated interaction energies between the normal (N) and alternative (A) conformations in kcal mole⁻¹ (a negative value means that the normal conformation is the more stable). When the difference is greater than 2 kcal mole⁻¹ only the more stable conformation is given. The normal conformation is the one in which the anomeric hydroxyl group is axial when it has the α and equatorial when it has the β configuration.¹ The original figures^{1a} have been extensively revised.^{1b}

Experimental support for most of these conformations is meager, but α - and β -D-glucose,³⁻⁵ α -L-rhamnose (6-deoxy-L-mannose),⁶ 2-amino-2-deoxy- β -D-glucose hydrochloride and hydrobromide,⁷ 2-acetamido-2-deoxy- α -D-glucose,^{8,9} potas-

sium β -D-glucuronate dihydrate,^{10,11} methyl 6-bromo-6-deoxy- α -D-galactopyranoside,¹² methyl β -D-xylopyranoside,^{13a} methyl α -D-glucopyranosides,^{13b} methyl 1-thio- β -D-xylopyranoside,¹⁴ dipotassium α -D-glucose-1-phosphate,¹⁵ methyl

3,4,6-tri-*O*-acetyl-2-chloromercuri-2-deoxy- β -D-glycopyranose,¹⁶ α -L-sorbose,¹⁷ the α -D-glucose residue of cyclohexaamylose,¹⁸ sucrose,¹⁹ and sucrose sodium bromide dihydrate,²⁰ the β -D-glucose residues of casimidine,²¹ cellobiose,^{22,23} and 1-*p*-bromophenyl-2- β -D-glycopyranosyl hydrazine,²⁴ the β -D-thioglyucose residue of sinigrin,^{25a} and the 6-amino-6-deoxy- α -D-glucopyranose²⁴ and 3-amino-3-deoxy- α -D-glucopyranose residues of kanamycin^{25b} have been shown by X-ray or neutron diffraction studies to exist in the expected conformations in the crystalline state. Similarly, β -D-lyxose has been shown to exist in the normal conformation,^{26,27} and β -D- and DL-arabinose,^{28,29} 2-deoxy- β -D-ribose,³⁰ and 1- α -D-arabinopyranosyl 2-*p*-bromophenyl hydrazine^{31a} exist in the alternative conformation.

The original hope that nmr spectroscopy would allow the precise conformations of carbohydrates in solution to be assigned is only just starting to be fulfilled. From the Karplus equation it should be possible to obtain values of the dihedral angle between hydrogen atoms on adjacent carbon atoms, but the problem is to decide first which form of the Karplus equation to use^{31b} and secondly to measure the coupling constants, since in a highly coupled system as a pyranose ring these are not generally equal to the observed spacings (for a discussion of this problem see ref 32).

The signal from the proton at C(1) is generally a doublet with spacing 5–10 cps when both it and the proton at C(2) would be expected to be axial and about 3 cps when they would both be expected to be equatorial or when one would

be expected to be equatorial and one axial (see ref 32). Whether the small variations in the values observed with different compounds signify small differences in conformation is not known at present. Recently the use of 100- and 220-Mcps spectra, spin decoupling, and exact spectral analysis using a computer (cf. ref 33a) has enabled the spacing of signals from protons other than those at C(1), and sometimes the true coupling constants, to be determined. Thus Lemieux and Stevens by working with 6,6'-dideuteriotetra-*O*-acetyl- α -D-glucopyranose and irradiating the signal from H(5) have been able to assign the spacings to all the protons directly attached to the pyranose ring.^{33b} The results (Table I) are in complete agreement with conformation 1 if the spacing of the signals from adjacent axial protons is taken to be 9–10 cps and from adjacent axial and equatorial protons to be 3–4 cps. Similarly, the spectra of 6,6'-dideuteriopenta-*O*-acetyl- β -D-glucopyranose (H(1) spacing 6.8 cps, H(5) spacing 9.0 cps) and penta-*O*-acetyl- β -D-allopyranose (signal from H(5) a triplet with spacing 1.8 cps) are also consistent with conformations 2 and 3, respectively (see also ref 34). The 60- and 100-Mcps nmr spectra of penta-*O*-acetyl- β -D-altropyranose (4)^{35a} and the 220-Mcps spectrum of penta-*O*-acetyl- α -D-idopyranose^{35b} suggest that they exist predominantly in the normal conformation.

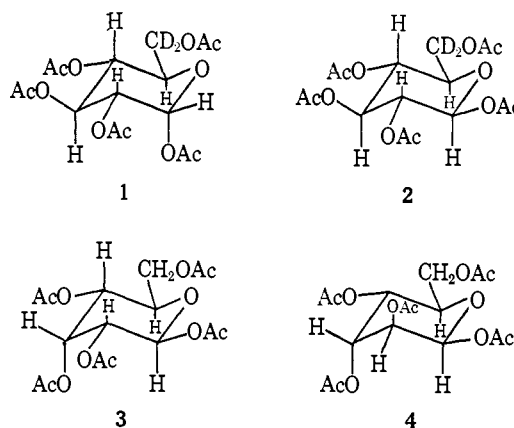

- (3) T. R. R. McDonald and C. A. Beevers, *Acta Crystallogr.*, **5**, 654 (1952).
- (4) G. M. Brown and H. A. Levy, *Science*, **147**, 1038 (1965).
- (5) (a) W. G. Ferrier, *Acta Crystallogr.*, **13**, 678 (1960); **16**, 1023 (1963); (b) S. S. C. Chu and G. A. Jeffrey, *ibid.*, **B24**, 830 (1968).
- (6) H. M. McGeachin and C. A. Beevers, *ibid.*, **10**, 227 (1957).
- (7) S. S. C. Chu and G. A. Jeffrey, *Proc. Roy. Soc.*, **A285**, 470 (1965).
- (8) L. N. Johnson and D. C. Phillips, *Nature*, **202**, 588 (1964).
- (9) L. N. Johnson, *Acta Crystallogr.*, **21**, 885 (1966).
- (10) G. E. Gurr, *ibid.*, **16**, 690 (1963).
- (11) S. Furberg, H. Hammer, and A. Mostad, *Acta Chem. Scand.*, **17**, 2444 (1963).
- (12) J. H. Robertson and B. Sheldrick, *Acta Crystallogr.*, **19**, 820 (1965).
- (13) (a) C. J. Brown, G. Cox, and F. J. Llewellyn, *J. Chem. Soc.*, **A**, 922 (1966); (b) H. M. Berman and S. H. Kim, *Acta Crystallogr.*, **B24**, 897 (1968).
- (14) A. M. Mathieson and B. J. Poppleton, *ibid.*, **21**, 72 (1966).
- (15) C. A. Beevers and G. H. Maconochie, *ibid.*, **18**, 232 (1965).
- (16) H. W. W. Ehrlich, *J. Chem. Soc.*, 509 (1962).
- (17) S. H. Kim and R. D. Rosenstein, *Acta Crystallogr.*, **22**, 648 (1967).
- (18) A. Hybl, R. E. Rundle, and D. E. Williams, *J. Amer. Chem. Soc.*, **87**, 2779 (1965).
- (19) G. M. Brown and H. A. Levy, *Science*, **141**, 921 (1963).
- (20) C. A. Beevers and W. Cochran, *Proc. Roy. Soc.*, **A190**, 257 (1947).
- (21) S. Raman, J. Reddy, and W. N. Lipscomb, *Acta Crystallogr.*, **16**, 364 (1962).
- (22) R. A. Jacobson, J. A. Wunderlich, and W. N. Lipscomb, *ibid.*, **14**, 598 (1961).
- (23) C. J. Brown, *J. Chem. Soc.*, **A**, 927 (1966).
- (24) T. Dukefos and A. Mostad, *Acta Chem. Scand.*, **19**, 685 (1965).
- (25) (a) J. Waser and W. H. Watson, *Nature*, **198**, 1297 (1963); (b) G. Koyama, Y. Iitaka, K. Maeda, and H. Umezawa, *Tetrahedron Lett.*, 1875 (1968).
- (26) A. Hordvik, *Acta Chem. Scand.*, **15**, 1781 (1961).
- (27) A. Hordvik, *ibid.*, **20**, 1943 (1966).
- (28) A. Hordvik, *ibid.*, **15**, 16 (1961).
- (29) S. H. Kim and G. A. Jeffrey, *Acta Crystallogr.*, **22**, 537 (1967).
- (30) S. Furberg, *Acta Chem. Scand.*, **14**, 1357 (1960).
- (31) (a) S. Furberg and C. S. Petersen, *ibid.*, **16**, 1539 (1962). (b) Vicinal coupling constants depend on dihedral angle, bond lengths, bond angles, electronegativities of substituents, and the orientation of substituents; cf. H. Booth, *Tetrahedron Letters*, 411 (1965); H. Booth and P. R. Thornburrow, *Chem. Ind. (London)*, 685 (1968).
- (32) L. D. Hall, *Advan. Carbohydrate Chem.*, **19**, 51 (1964).

Analysis of the 220-Mcps spectrum of 1-thio- α -L-arabinopyranose tetraacetate indicates that the alternative conformation predominates. The spacings of the signals from the axial protons of C(1), C(2), and C(3) are *ca.* 7.5 cps which is less than found with the glucose derivatives mentioned above for which values of 9–10 cps were obtained. Possibly the arabinose derivative exists appreciably in the normal conformation, but no change in the spectrum could be observed on cooling to -30° .^{35b}

The existence of two conformers of tetra-*O*-acetyl- β -D-ribose has been demonstrated by the low-temperature, 220-Mcps spectrum. At 20° the signal of the anomeric proton is a doublet with spacing 4.8 cps, but at -80° two signals are observed with spacings 1.0 and 8.0 cps. The former was attributed to the alternative and the latter to the normal conformation, present in the ratio of 2:1 ($\Delta G^{\circ} = 0.3$ kcal mole⁻¹). The coalescence temperature of the two signals is

- (33) (a) P. Nuhn, W. Bley, and G. Wagner, *Arch. Pharm. (Weinheim)*, **301**, 926 (1967); C. B. Barlow, E. O. Bishop, P. R. Carey, R. D. Guthrie, M. A. Jensen, and J. E. Lewis, *Tetrahedron*, **24**, 4517 (1968); (b) R. U. Lemieux and J. D. Stevens, *Can. J. Chem.*, **43**, 2059 (1965).
- (34) T. D. Inch, J. R. Plimmer, and H. G. Fletcher, *J. Org. Chem.*, **31**, 1825 (1966).
- (35) (a) B. Coxon, *Carbohydr. Res.*, **1**, 357 (1966); (b) C. V. Holland, D. Horton, M. J. Miller, and N. S. Bhacca, *J. Org. Chem.*, **32**, 3077 (1967); N. S. Bhacca and D. Horton, *Chem. Commun.*, **32**, 867 (1967); (c) *J. Org. Chem.*, **33**, 2484 (1968).

Table I
Spacings of the Signals from the Ring Protons of Penta-*O*-acetyl- α -D-glucopyranose^{32b}

Signal from	Observed in	With irradiation of the signal from H(5)	δ multiplicity, ppm	Spacing, cps
H(1)	Penta- <i>O</i> -acetyl- α -D-glucopyranose	No	6.35 doublet	3.3
H(2)	6,6'-Dideuteriopenta- <i>O</i> -acetyl- α -D-glucopyranose	Yes	5.08 quartet	4.0, 10.0
H(3)	6,6'-Dideuteriopenta- <i>O</i> -acetyl- α -D-glucopyranose	Yes	5.5 quartet	9.4, 10.0
H(4)	6,6'-Dideuteriopenta- <i>O</i> -acetyl- α -D-glucopyranose	Yes	5.13 triplet	10.0
H(5)	6,6'-Dideuteriopenta- <i>O</i> -acetyl- α -D-glucopyranose	No	4.12 doublet	10.0

Table II
Anomeric Equilibria of D-Glucopyranose and D-Mannopyranose Derivatives

Derivative	Solvent	Temp., °C	% α	% β	K (β/α)	ΔG° , kcal mole ⁻¹	Ref
D-Glucopyranose Derivatives							
Free sugar	H ₂ O	20	36.2	63.8	1.75	-0.33	48
Free sugar	CH ₃ OH	25-45	50.1	49.9	1.00	0.00	49
Methyl glucosides	CH ₃ OH	35	76.8	23.2	0.302	0.73	50
Penta- <i>O</i> -acetate	1:1 AcOH-Ac ₂ O	25	84.0	16.0	0.191	0.98	51
Tetra- <i>O</i> -acetylglucosyl chloride	CH ₃ CN	30	94	6	0.062	1.60	52
D-Mannopyranose Derivatives							
Free sugar	H ₂ O	20	68.8	31.2	0.45	0.46	48
Penta- <i>O</i> -acetate	1:1 AcOH-Ac ₂ O	25	86.0	14.0	0.163	1.07	51

-60° at which temperature the rate constant for inversion is ca. 130 sec⁻¹.^{36b}

An important difference between pyranose derivatives of carbohydrates and cyclohexane derivatives is that with the former substituents at carbon 1 usually show a preference for the axial position. This has been termed the anomeric effect^{36a} and is seen most clearly by considering derivatives of glucose since these are generally locked in the normal conformation by the strong preference of the substituents at C(2)-C(5) for the equatorial position. An equilibrium between α and β derivatives is thus an axial-equatorial equilibrium, and the composition of the equilibrium mixture from several derivatives is given in Table II. Only the equilibrium between the free sugars favors the equatorial (β) form, but the proportion of this present at equilibrium is less than with the cyclohexanols. Probably the factor which favors the stability of β -D-glucose in water is that the equatorial hydroxyl group is more easily solvated than the axial one. It has in fact been suggested that β -D-glucopyranose fits into the water structure more effectively than α -D-glucopyranose.^{37,38}

The anomeric effect is larger with halogeno- than with oxygen-containing substituents and is large enough to cause tri-*O*-acetyl- β -D-xylosyl chloride and fluoride to exist in the all-axial conformation 5.^{39,40} It is also found with other

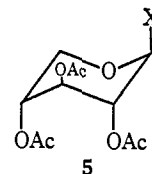

derivatives of tetrahydropyran besides carbohydrates. Thus the proportions of equatorial conformers of 2-chloro- and 2-bromotetrahydropyran are "too small to be detected by NMR analysis,"⁴¹ and the proportion of *trans*- to *cis*-2-chloro-4-methyltetrahydropyran (6 and 7) present at equilibrium is 97:3.⁴² This latter result enabled a quantitative measure of the anomeric effect to be made as the observed free-energy difference (2.15 kcal mole⁻¹) plus the A value for the chloro group (0.5 kcal mole⁻¹) or 2.65 kcal mole⁻¹. The anomeric effect for the bromo and iodo groups was estimated

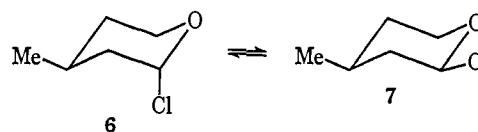

similarly to be greater than 3.1-3.2 kcal mole⁻¹.

The *trans*-axial forms of 2-methoxy- and 2-acetoxy-4-methyltetrahydropyran (8) are also more stable than their *cis*-equatorial isomers (9).⁴³ The equilibrium mixtures here contain 65 and 70-75%, respectively, of the axial forms with a slight solvent dependence, which was interpreted as being consistent

(36) (a) R. U. Lemieux, "Molecular Rearrangements," P. de Mayo, Ed., Interscience Division of John Wiley and Sons, Inc., New York, N. Y., 1964, p 735. It is considered by some that the term anomeric effect is unnecessary; cf. W. D. Ollis and J. H. Ridd, *Ann. Rept. Progr. Chem.* (Chem. Soc. London), 63, 240 (1966); (b) N. S. Bhacca and D. Horton, *J. Amer. Chem. Soc.*, 89, 5993 (1967); see also P. L. Durette and D. Horton, *Chem. Commun.*, 516 (1969).

(37) M. A. Kabayama, D. Patterson, and L. Piche, *Can. J. Chem.*, 36, 557 (1958).

(38) M. A. Kabayama and D. Patterson, *ibid.*, 36, 563 (1958).

(39) C. V. Holland, D. Horton, and J. S. Jewell, *J. Org. Chem.*, 32, 1818 (1967).

(40) L. D. Hall and J. F. Manville, *Carbohydr. Res.*, 4, 512 (1967).

(41) G. E. Booth and R. L. Ouellette, *J. Org. Chem.*, 31, 544 (1966).

(42) C. B. Anderson and D. T. Sepp, *ibid.*, 32, 607 (1967).

(43) C. B. Anderson and D. T. Sepp, *Chem. Ind.* (London), 2054 (1964); *Tetrahedron*, 24, 1707 (1968); see also *ibid.*, 24, 6873 (1968); F. Sweet and R. K. Brown, *Can. J. Chem.*, 46, 1543 (1968); E. L. Eliel and C. A. Giza, *J. Org. Chem.*, 33, 3754 (1968); G. O. Pierson and O. A. Runquist, *ibid.*, 33, 2572 (1968); N. S. Zefirov and N. M. Schekhtman, *Dokl. Akad. Nauk SSSR*, 180, 1363 (1968).

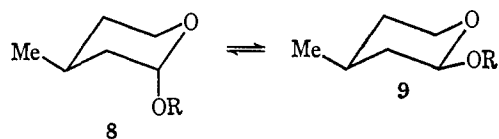

with the anomeric effect arising from an unfavorable dipole interaction in the equatorial form (see below). It has also been shown that the axial α forms of 3-alkoxy-4-oxa-5 α -cholestanes **10**,^{44,45} and 3-methoxy-4-oxa-5 α -estrans **12**⁴⁶ predominate over their β -equatorial anomers **11** and **13** at equilibrium and

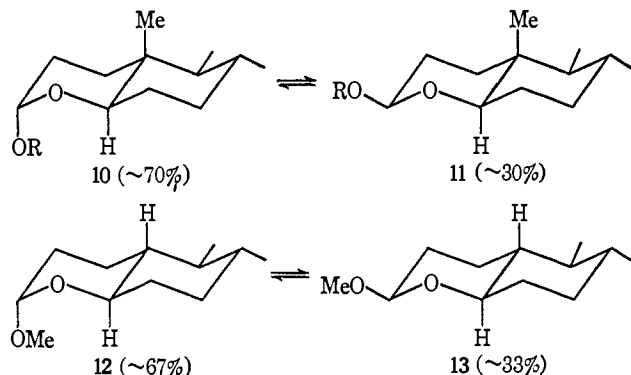

that 2-methoxy- and 2-ethoxycarbonyl-1,4-benzodioxan exist to the extent of about 70% in a conformation with the substituent axial.⁴⁷

Halogenodioxans and dithianes also show a strong preference for conformations with the halogens in axial positions. This has been shown for *trans*-2,3-dichloro-1,4-dioxane^{53,54} (see also ref 55-57), *trans*-2,4-dichloro-1,4-dioxane,^{53,58} *trans*-2,3-dibromo-1,4-dioxane,^{53,59} *trans*-2,3-dichloro-1,4-dithiane,^{60,61} *trans*-2,3-dibromo-1,4-dithiane,^{61,62} and *trans*-2,3-dichloro-1,4-thioxane⁶³ by X-ray analysis of the crystalline state at low temperatures and by dipole moment measurements of benzene solutions.

The anomeric effect has been explained as the result of the interaction of the dipole of the substituent with that of the ring

oxygen being more favorable with the axial than with the equatorial isomer.⁶⁴ Thus in an axially substituted 2-methoxytetrahydropyran (**14a**) these dipoles are antiparallel, but with the equatorial isomer (**14b**) they are approximately perpendicular.^{64b} Similarly, the dipole interaction is more favorable in an axial than in an equatorial 2-halogenotetrahydropyran (see **15** and **16**), and a larger effect would be expected because the dipoles are closer.^{64b} This interpretation is therefore supported by the proportion of axial isomer present at equilibrium being larger when the substituent is halogen than when it is

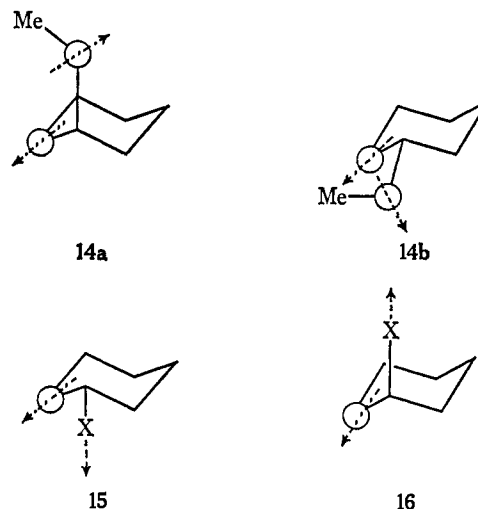

oxygen, and by calculations^{42,43,64b} of the difference in the dipole-dipole interaction energies between isomers which is of the correct order of magnitude to account for the anomeric effect. It has been criticized, however, since the X-ray analysis of *cis*-2,3-dichlorodioxane shows that the equatorial chlorine atom is bent toward the ring oxygen atom.^{65a} It was also shown, with the dichlorodioxanes mentioned above, that the axial (but not the equatorial) carbon-chlorine bond is longer than usual and that the adjacent carbon-oxygen bond is shortened.^{65b} A stereoelectronic explanation of the anomeric effect was therefore favored. It was suggested that the axial lone pair on the ring oxygen is suitably disposed for filling the antibonding orbital of the axial carbon-chlorine bond (see **17**). This explanation is also in accord with the conforma-

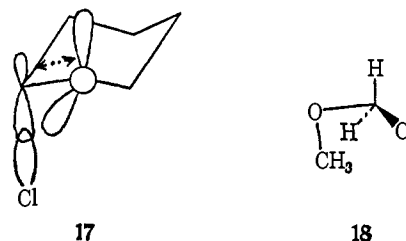

(64) (a) R. U. Lemieux and N. J. Chu, Abstracts, 133rd National Meeting of the American Chemical Society, San Francisco, Calif., April 1958, No. N31; (b) F. G. Riddle, *Quart. Rev.* (London), 21, 373 (1967).

(65) C. Altona, Thesis, Leiden, 1964, p 115. (b) It has been shown by a recent survey of the C-O bond lengths of free sugars and glycosides that the equatorial C(1)-O(1) bond is 0.02-0.05 Å shorter than the mean C-O bond length of the other C-O bonds in the molecule. Axial C(1)-O(1) bonds also appear to be shortened by a similar amount in free sugars but probably not in glycosides. Those molecules which have shortened C(1)-O(1) bonds appear to have lengthened ring C-O bonds (C(1)-O(5) and C(5)-O(5)) which are of similar lengths, but the "normal" C(1)-O(1) bond lengths of α -glycosides are accompanied by a shortened C(1)-O(5) bond so that in these compounds the two C-O bond of the ring have significantly different lengths; H. M. Berman, S. S. C. Chu, and G. A. Jeffrey, *Science*, 157, 1576 (1967); see also M. Sundaralingam, *Biopolymers*, 6, 189, 1778 (1968).

(44) J. T. Edward, P. R. Morand, and I. Puskas, *Can. J. Chem.*, 39, 2069 (1961).

(45) J. T. Edward and I. Puskas, *ibid.*, 40, 711 (1962).

(46) J. T. Edward and J.-M. Ferland, *ibid.*, 44, 1299 (1966).

(47) A. R. Katritzky, A. M. Monro, G. W. H. Potter, R. E. Reavill, and M. J. Sewell, *Chem. Commun.*, 58 (1965).

(48) H. S. Isbell and W. W. Pigman, *J. Res. Nat. Bur. Stand.*, 18, 141 (1937).

(49) H. H. Rowley and S. D. Bailey, *J. Amer. Chem. Soc.*, 62, 2562 (1940).

(50) G. W. Loveday, unpublished observation.

(51) W. A. Bonner, *J. Amer. Chem. Soc.*, 81, 1451 (1959).

(52) R. U. Lemieux and J.-I. Hayami, *Can. J. Chem.*, 43, 2162 (1965).

(53) C. Altona, C. Romers, and E. Havinga, *Tetrahedron Lett.*, No. 10, 16 (1959).

(54) C. Altona and C. Romers, *Rec. Trav. Chim. Pays-Bas*, 82, 1080 (1963).

(55) C.-Y. Chen and R. J. W. Le Fevre, *J. Chem. Soc., B*, 544 (1966).

(56) R. R. Fraser and C. Reyes-Zumora, *Can. J. Chem.*, 43, 3445 (1965).

(57) D. Jung, *Chem. Ber.*, 99, 566 (1966).

(58) C. Altona, C. Knobler, and C. Romers, *Acta Crystallogr.*, 16, 1217 (1963).

(59) C. Altona, C. Knobler, and C. Romers, *Rec. Trav. Chim. Pays-Bas*, 82, 1089 (1963).

(60) H. T. Kalf and C. Romers, *Acta Crystallogr.*, 18, 164 (1965).

(61) H. T. Kalf and E. Havinga, *Rec. Trav. Chim. Pays-Bas*, 85, 637 (1966).

(62) H. T. Kalf and C. Romers, *ibid.*, 85, 198 (1966).

(63) N. de Wolf, C. Romers, and C. Altona, *Acta Crystallogr.*, 22, 715 (1967).

tion of chloromethyl ether being that with the chlorine *gauche* to the methyl group, *i.e.*, **18**, which is supported by most of evidence^{66,67} (see, however, ref 68). A "full account and possible explanation" of the anomeric effect is promised shortly.⁶⁹

The anomeric equilibria of derivatives of mannose in which the substituent at C(2) is axial favor the α anomer even more than with the corresponding glucose derivatives (see Table II). This has been attributed to further destabilization of the β anomers by additional dipole interactions which have been named the $\Delta 2$ effect and computed to amount to a destabilization of 0.45 kcal mole⁻¹.

In contrast to the above results, it appears that a positively charged 1-pyridyl residue has a very strong tendency to take up an equatorial position.⁷⁰ Thus the 100-Mcps nmr spectrum of tetra-*O*-acetylated 4-methylpyridinium α -D-glucoside in which the signals of the ring protons are well separated affords coupling constants $J_{1,2} = 2.8$, $J_{2,3} = 3.1$, $J_{3,4} = 3.2$, and $J_{4,5} = 5.7$ cps, and the signals from three of the acetoxy groups appear at positions normally found for axial groups. These results therefore suggest a conformation (**19**) in which the protons on C(2) to C(5) occupy equatorial or nearly equatorial positions. Since the energy required to place the substituents of C(2) to C(5) in axial positions is probably at least 4 kcal mole⁻¹, it would appear that the preference of the 4-methylpyridinium residue at C(1) for the equatorial position amounts to at least 5–6 kcal mole⁻¹. 7-(2',3',4',6'-Tetra-*O*-acetyl- α -D-mannopyranosyl)theophylline and 7- α -D-mannopyranosyltheophylline have also been shown to exist in the alternative conformation,⁷¹ and presumably *N*-(tetra-*O*-acetyl-D-glucopyranosyl)-3-carboxamidopyridinium bromide whose 60-Mcps nmr spectrum was previously discussed in terms of the normal conformation⁷² does as well.

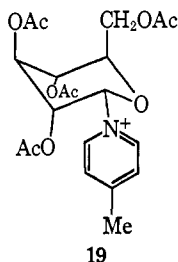

The conformational analysis of furanose sugars is on less sure ground than that of pyranose. By analogy with cyclopentane, envelope (CS) and twist-chair (C2) forms would be expected, with several conformations possibly having similar energies. It was first pointed out by Spencer⁷³ that the most likely envelope conformations for the deoxyribose rings in DNA should be those with C(2') or C(3') displaced from the plane of the other four ring atoms since these allow the maximum number of eclipsing interactions ("short contacts") to be relieved (compare, for example, **20** with **21**).⁷⁴ Four con-

formations with C(2') or C(3') displaced (**22–25**) are possible

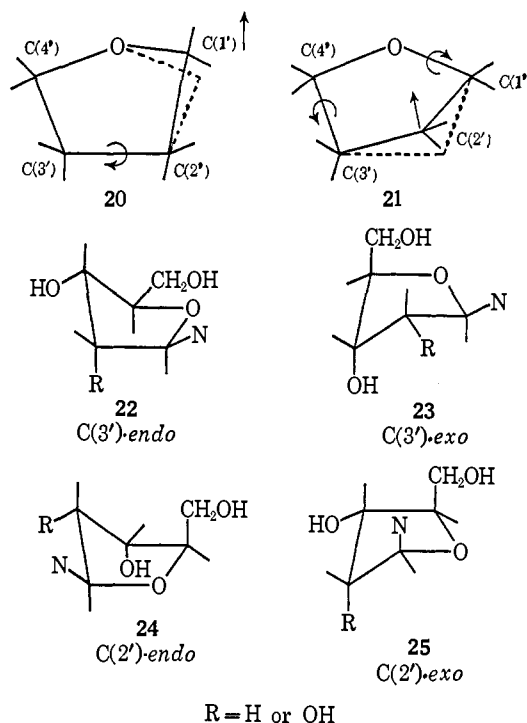

since the displacement may be on the same or opposite side to C(5'). Spencer's predictions have been born out by a large number of X-ray structure determinations on nucleosides and nucleotides.^{75,76} With all the compounds studied so far (Table III), the ribo- or deoxyribofuranose ring has either the C(3')-endo, C(3')-exo, or C(2')-endo conformation. The only other furanose ring which has been investigated crystallographically is the fructofuranoside ring of sucrose in sucrose itself,¹⁹ and in sucrose sodium bromide dihydrate.^{20,77c} In the latter a conformation (**26**) analogous to the C(3')-endo conformation of nucleosides was found, with C(4) displaced from the plane.

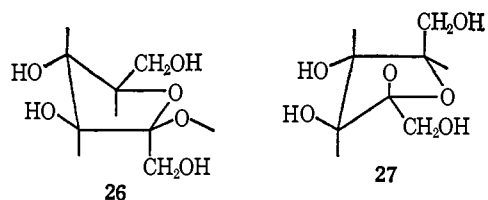

Brown and Levy concluded from their neutron diffraction analysis of sucrose itself that the conformation of the fructofuranoside ring was here more complex and could not be so simply described.¹⁹ According to Sundaralingam, however, there is a best least-squares plane through C(2), C(4), C(5), and O(5) with C(3) 0.542 Å below it.^{77a} The conformation is

(75) M. Sundaralingam and L. H. Jensen, *J. Mol. Biol.*, **13**, 930 (1965).

(76) A. E. V. Haschenmeyer and A. Rich, *ibid.*, **27**, 369 (1967).

(77) (a) M. Sundaralingam, *J. Amer. Chem. Soc.*, **87**, 599 (1965).

(b) See, however, the discussion of R. U. Lemieux and R. Nagarajan, *Can. J. Chem.*, **42**, 1270 (1964), who suggest that "the ring oxygen atom will tend to occupy a central position in that portion of the ring where four of the ring atoms are nearest to coplanarity" and that "in general furanose rings will tend to be puckered in such a manner as to have a carbon *meta* to the ring oxygen (either the 2- or the 3-carbon for aldofuranosides; either the 3- or 4-carbons for ketofuranosides) furthest out of the mean plane of the ring" (authors' italics). This suggestion should be compared with the tentative conformations assigned in ref 97b and c. (c) The conformation of methyl α -D-lyxopyranoside in the crystalline state has recently been shown to be C(3)-endo: P. Gvoth and H. Hammer, *Acta Chem. Scand.*, **22**, 2059 (1968); (d) F. E. Hruska and S. S. Danyluk, *J. Amer. Chem. Soc.*, **90**, 3266 (1968); see also S. I. Chan and J. H. Nelson, *ibid.*, **91**, 168 (1969).

(66) M. C. Planje, L. H. Toneman, and G. Dallinga, *Rec. Trav. Chim. Pays-Bas*, **84**, 232 (1965).

(67) M. J. Aroney, R. J. W. Le Fevre, and J. D. Saxby, *J. Chem. Soc., Chem.*, **31**, 2403 (1966).

(68) R. G. Jones and W. J. Orville-Thomas, *ibid.*, 692 (1964).

(69) C. Altona and M. Sundaralingam, quoted in ref 63.

(70) R. U. Lemieux and A. R. Morgan, *Can. J. Chem.*, **43**, 2205 (1965).

(71) K. Onodera, S. Hirano, F. Masuda, and N. Kashimura, *J. Org. Chem.*, **31**, 2403 (1966); see also K. Onodera, S. Hirano, and F. Masuda, *Carbohydr. Res.*, **7**, 27 (1968).

(72) R. U. Lemieux and J. W. Lown, *Can. J. Chem.*, **41**, 889 (1963).

(73) M. Spencer, *Acta Crystallogr.*, **12**, 59 (1959).

(74) This ignores interactions by the lone pairs on the ring oxygen.

Table III
Conformations of D-Ribo- and 2-Deoxy-D-ribofuranose Rings in Nucleosides, Nucleotides, and Related Compounds^b

Compound	Base ^a	Conformation	Displacement, Å	Ref
D-Ribofuranose Ring				
Cytidine	Pyr	C(3')-endo	-0.50	78
5-Bromouridine	Pyr	C(2')-endo	-0.5	79a
5-Bromouridine-DMSO complex	Pyr	C(2')-endo	-0.6	79b
Cytidine 3'-(dihydrogen phosphate)	Pyr	C(2')-endo	-0.609	80-82
Adenosine 3'-dihydrogen phosphate dihydrate	Pur	C(3')-endo	-0.562	83
Adenosine 5'-(dihydrogen phosphate)	Pur	C(3')-endo	-0.664	84
Uridine 5'-(barium phosphate)	Pyr	C(2')-endo	-0.52	85
α -D-Ribose 5-(barium phosphate)	...	C(2')-endo	-0.5	86a
Uridine 3',5'-cyclic phosphate	Pyr	C(3')-endo	0.64, 0.58	86b
Hydrogen-bonded complex of adenosine and 5-bromouridine				
Adenosine	Pur	C(3')-endo	-0.620	87
5-Bromouridine	Pyr	C(3')-endo	-0.591	87
β -Adenosine-2'- β -uridine-5'-phosphoric acid				
Adenosine	Pur	C(2')-endo	-0.62	88
Uridine	Pyr	C(3')-exo	+0.60	88
5-Deoxyadenosylcobalamine	Pur	C(3')-endo	-0.75	89a
Vitamin B ₁₂	...	C(2')-endo	-0.72	89b
2-Deoxy-D-ribofuranose Ring				
Thymidine 5'-(calcium phosphate)	Pyr	C(3')-endo	-0.664	84
Thymidine	Pyr	C(3')-exo	+0.5	90a
2'-Deoxyadenosine	Pur	C(3')-exo	+0.552	90b
5-Fluoro-2'-deoxyuridine	Pyr	C(2')-endo	-0.629	91
5-Iodo-2'-deoxyuridine	Pyr	C(2')-endo	-0.59	92
5-Bromo-2'-deoxyuridine	Pyr	C(2')-endo	-0.59	79
5-Bromo-5'-deoxythymidine	Pyr	C(3')-endo	-0.44	93
Hydrogen-bonded complex of 5-bromodeoxy-cytidine and deoxyguanosine				
Deoxycytidine	Pyr	C(2')-endo	-0.54	94
Deoxyguanosine	Pur	C(2')-endo	-0.45	94

^a Note the apparent absence of a correlation between the conformation and the structure of the base. Pyr = pyrimidine; Pur = purine.

^b The ribose ring of the sodium salt of inosine 5'-monophosphate, a purine nucleotide, has recently been reported to have the C(2')-endo conformation: S. T. Rao and M. Sundaralingam, *Chem. Commun.*, 995 (1968); *J. Amer. Chem. Soc.*, **91**, 1210 (1969); see also N. Nagashima and Y. Iitaka, *Acta Crystallogr.*, **B24**, 1136 (1968).

therefore as **27**, analogous to the C(2')-exo conformation of nucleosides. Thus the four envelope conformations of furanose rings predicted by Spencer have been observed to the exclusion of all others. These conformations are of course those present in the crystalline state, and the fact that only small changes in structure can result in a change in conformation suggests that in solution more than one conformation may be present. Because of their biological interest X-ray crystallographers have concentrated their attention on derivatives of β -D-ribo- and β -D-2-deoxyribofuranose derivatives, and these may or may not be typical of furanose sugars as a whole. The possibility that the furanose rings of other sugars may have envelope conformations with C(1), C(4), or O(4) displaced from the plane or twist-chair conformations cannot therefore be entirely ruled out.^{77b}

It has been shown recently that the nmr spectra of dinucleoside diphosphates in D₂O change with temperature in the range 4-80°. For instance, the spacings of the H(1') protons of adenylyl(3'→5')adenosine change from 2.3 and 2.1 cps at 4° to 4.7 and 4.5 cps at 71°. This was interpreted as resulting from a change in the conformation of the ribofuranose rings from C(3')-endo at low temperatures when the bases are stacked to C(2')-endo at high temperatures when they are unstacked. The change in the spacings of the signals from the H(1') protons of mononucleotides are smaller and were not considered to be significant. Nevertheless the H(1') spacing of one of the two compounds studied, adenosine 3'-monophos-

phate, changed from 6.1 cps at 4° to 5.1 cps at 80°, outside the quoted experimental error of ± 0.1 cps. It is not clear if this results from a conformational change or from some other cause.^{77a}

The X-ray structure determinations have also shown that the exocyclic C(5')H₂O(5') group of nucleosides and nucleotides in the crystalline state generally has conformation **28** with the C(5')-O(5') bond approximately bisecting the O(1')-C(4')-C(3') bond angle^{85,75} (but see ref 79a and 86b). With hexopyranose derivatives, however, the conformation of the C(6)H₂O(6) group is not always similar. Thus although

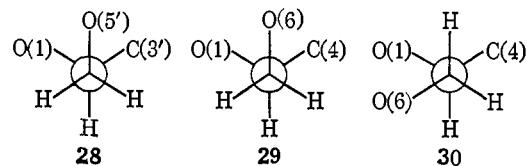

(78) S. Furberg, *Acta Crystallogr.*, **3**, 325 (1950).

(79) (a) J. Iball, C. H. Morgan, and H. R. Wilson, *Proc. Roy. Soc.*, **A295**, 320 (1966); (b) *ibid.*, **302**, 230 (1968).

(80) E. Alver and S. Furberg, *Acta Chem. Scand.*, **13**, 910 (1959).

(81) M. Sundaralingam and L. H. Jensen, *J. Mol. Biol.*, **13**, 914 (1965).

(82) C. E. Bugg and R. E. Marsh, *ibid.*, **25**, 67 (1967).

(83) M. Sundaralingam, *Acta Crystallogr.*, **21**, 495 (1966).

(84) J. Kraut and L. H. Jensen, *ibid.*, **16**, 79 (1963).

(85) E. Shefter and K. N. Trueblood, *ibid.*, **18**, 1067 (1965).

(86) (a) S. Furberg and A. Mostad, *Acta Chem. Scand.*, **16**, 1627 (1962); (b) C. L. Coulter, *Science*, **159**, 888 (1968); (c) L. D. Hall, J. F. Manville, and N. S. Bhacca, *Can. J. Chem.*, **47**, 1 (1969).

this bond in crystalline β -D-glucose has conformation **29**, in α -D-glucose and in the β -D-glucose residues of cellobiose it has conformation **30**.^{85,86}

A number of attempts have been made to assign conformations to furanose rings in solution by nmr spectroscopy,^{95-97b} but in view of the uncertainties of the Karplus equation and of the possibility that more than one conformation may be present, these can only be regarded as very tentative.⁹⁸

The anomeric equilibria of furanose derivatives of free sugars (Table XLIXA) and methyl furanosides (Table IV⁹⁹⁻¹⁰¹) favor the anomers with the substituents at C(1) and C(2) *trans* to one another. The pyranose forms are generally more stable than furanose (see Tables V and XLIXA¹⁰²⁻¹⁰⁵), as would be expected from considerations of ring strain. It appears, however, that when the furanose ring lacks *cis* substituents at C(3) and C(4), it is relatively highly favored (compare glucose with allose and 3-deoxyglucose).¹⁰⁶ Methylation of the 2- and/or 3-hydroxyl groups of methyl xyloside and arabinoside¹⁰¹ and of arabinose, galactose, and altrose¹⁰⁷ increases the relative stabilities of the furanose forms (see, *e.g.*, Table XLIXB). The results for the arabinoside and xyloside were interpreted as arising from the distance apart of equatorial-equatorial substituents at C(2) and C(3) in the pyranose ring being less than that of similar *trans* substituents in the furanose ring. It was then thought that methylation would result in a larger increase in nonbonding interactions with furanosides than with pyranosides.¹⁰¹ This explanation seems reasonable, but it is apparently not applicable to the free sugars as even altrose, which has axial substituents at C(2) and C(3) in the pyranose form, shows an increase in the proportion of furanose forms on methylation. It was suggested that the hydroxyl groups of pyranose sugars are solvated better than those of furanose ones in aqueous solutions by hydrogen bonding and that this stabilizing factor is lost on methylation.¹⁰⁷ However, it should be noted that the proportions of furanose forms present in dimethyl sulfoxide solution also increase on methylation.

(87) A. E. V. Haschenmeyer and H. M. Sobell, *Acta Crystallogr.*, **18**, 525 (1965).

(88) E. Shefter, M. Barlow, R. Sparks, and K. N. Trueblood, *J. Amer. Chem. Soc.*, **86**, 1872 (1964).

(89) (a) P. G. Lenhart, *Proc. Roy. Soc.*, **A303**, 45 (1968); (b) D. C. Hodgkin, J. Lindsey, R. A. Sparks, K. N. Trueblood, and J. G. White, *ibid.*, **A266**, 494 (1962).

(90) (a) P. Tollin, H. R. Wilson, and D. W. Young, *Nature*, **217**, 1149 (1968); (b) D. G. Watson, D. J. Sutor, and P. Tollin, private communications to M. Sundaralingam quoted in ref 77a.

(91) D. R. Harris and W. M. McIntyre, *Biophys. J.*, **4**, 203 (1964).

(92) N. Camerman and J. Trotter, *Acta Crystallogr.*, **18**, 203 (1965).

(93) P. M. Huber, *ibid.*, **10**, 129 (1957).

(94) A. E. V. Haschenmeyer and H. M. Sobell, *ibid.*, **19**, 125 (1965).

(95) C. D. Jardetzky, *J. Amer. Chem. Soc.*, **82**, 229 (1960); **83**, 2919 (1961); **84**, 62 (1962).

(96) R. U. Lemieux *Can. J. Chem.*, **39**, 116 (1961).

(97) (a) R. J. Abraham, L. D. Hall, L. Hough, and K. A. McLaughlan, *J. Chem. Soc.*, 3699 (1962); (b) J. D. Stevens and H. G. Fletcher, *J. Org. Chem.*, **33**, 1799 (1968); (c) R. J. Cushley, J. F. Codington, and J. J. Fox, *Can. J. Chem.*, **46**, 1131 (1968).

(98) R. U. Lemieux and D. R. Lineback, *Ann. Rev. Biochem.*, **32**, 155 (1963).

(99) B. Capon, G. W. Loveday, and W. G. Overend, *Chem. Ind. (London)*, 1537 (1962).

(100) C. T. Bishop and F. P. Cooper, *Can. J. Chem.*, **40**, 224 (1962).

(101) C. T. Bishop and F. P. Cooper, *ibid.*, **41**, 2743 (1963).

(102) D. F. Mowery, *J. Org. Chem.*, **26**, 3484 (1961).

(103) H. W. H. Schmidt and H. Neukom, *Helv. Chim. Acta*, **49**, 510 (1966).

(104) R. S. Shallenberger and D. E. Acree, *Carbohydr. Res.*, **1**, 495 (1966).

(105) R. U. Lemieux and J. D. Stevens, *Can. J. Chem.*, **44**, 249 (1966).

(106) S. J. Angyal and V. A. Pickles, *Carbohydr. Res.*, **4**, 269 (1967).

(107) W. Mackie and A. S. Perlin, *Can. J. Chem.*, **44**, 2039 (1966).

There is virtually no evidence^{108a} concerning the conformations taken up by acyclic sugar derivatives in solution. One may speculate though by considering first the planar zig-zag conformation which has been shown to be that of potassium D-gluconate,^{108b} the Ca and Sr salts of L-arabinonic acid,^{109a} galactitol,^{109b} D-mannitol,^{109c} and DL-arabitol^{109d} in the crystalline state. The most important destabilizing interaction in this conformation should be that between two groups 1,3 to one another on the same side of the chain which are approximately 2.5 Å apart, *i.e.*, the same distance as 1,2 substituents in an eclipsed conformation. D-Idose (**36**) and D-allose (**37**) have two of these 1,3 interactions; D-glucose (**38**), D-altrose (**39**), D-talose (**40**), and D-gulose (**41**) have one; and D-galactose (**42**) and D-mannose (**43**) have none. The relative stability of

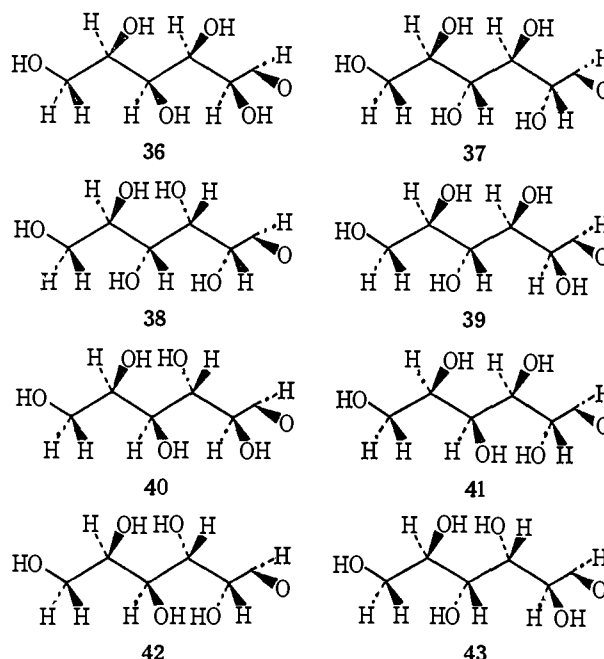

the zig-zag conformation of acyclic derivatives of these sugars would therefore be expected to decrease in this order, that for D-idose in which all the hydroxyls are on the same side of the chain being particularly unstable. Indeed it seems likely that this 1,3 interaction is so unfavorable that there will be appreciable concentrations of other conformations present in solutions of those sugar derivatives with which it is found.^{109e} Thus it has been shown that the relative rates of ring closure of 1,5-di-*O*-*p*-toluenesulfonyl-2,3,4-tri-*O*-benzylribitol, xylitol, and arabinitol are explained best in terms of conformations in which there is maximum separation of the substituents.¹¹⁰

(108) (a) An important investigation of the conformations of sugar osotriazoles has recently been reported: H. S. El Khadem, D. Horton, and T. F. Page, *J. Org. Chem.*, **33**, 734 (1968); see also G. G. Lyle and M. J. Piazza, *ibid.*, **33**, 2478 (1968); (b) C. D. Littleton, *Acta Crystallogr.*, **6**, 775 (1963).

(109) (a) S. Furberg and S. Helland, *Acta Chem. Scand.*, **16**, 2373 (1962); (b) H. M. Berman and R. D. Rosenstein, *Acta Crystallogr.*, **B24**, 435 (1968); (c) H. M. Berman, G. A. Jeffrey, and R. D. Rosenstein, *ibid.*, **B24**, 442 (1968); (d) F. D. Hunter and R. D. Rosenstein, *ibid.*, **B24**, 1652 (1968). (e) It appears that the ribitol chain in crystalline riboflavin hydrobromide monohydrate has a conformation in which the C(2')-C(1') and C(3')-C(4') bonds are *gauche* to one another when viewed along the C(2')-C(3') bond: N. Tanaha, T. Ashida, Y. Sasada, and M. Kakudo, *Bull. Chem. Soc. Jap.*, **40**, 1739 (1967). The nmr spectra of several polyhydroxyalkylquinoxalines and their acetates suggest that appreciable concentrations of non-zig-zag conformations are present in solutions in DMSO and CCl₄, respectively: W. S. Chilton and R. C. Krahn, *J. Amer. Chem. Soc.*, **90**, 1318 (1968).

(110) G. R. Gray, F. C. Hartman, and R. Barker, *J. Org. Chem.*, **30**, 2020 (1965).

Table IV
Percentages of Methyl α - and β -Aldofuranosides Present at Their Pseudo-equilibrium in Methanol

Furanoside	% α	% β	Temp., °C	Catalyst	Method	Ref
D-Gluco- (31)	37	63	35.2	0.1 M MeSO ₃ H	Optical rotation	99
D-Xylo- (32)	37	63	35	1% HCl	Glpc	100, 101
D-Arabino- (33)	76	24	35	1% HCl	Glpc	101
D-Lyxo- (34)	~100	~0	35	1% HCl	Glpc	101
D-Ribo- (35)	23	77	35	1% HCl	Glpc	101

Table V
Percentages of Pyranose and Furanose Forms of Sugar Derivatives Present at Equilibrium

Derivatives	Solvent	Temp., °C	Percentages				Ref ^a
			α -Pyr	β -Pyr	α -Fur	β -Fur	
Methyl D-xylosides	CH ₃ OH ^a	35	65.1	29.8	1.9	3.2	100, 101
Methyl D-arabinosides	CH ₃ OH ^a	35	24.5	47.2	21.5	6.8	101
Methyl L-arabinosides	CH ₃ OH ^b	65	24	45	23	8	102
Methyl D-lyxosides	CH ₃ OH ^a	35	88.3	10.3	1.4	Not detected	101
Methyl D-ribosides	CH ₃ OH ^a	35	11.6	65.8	5.2	17.4	101
Methyl D-mannosides	CH ₃ OH ^b	65	89	7	2	2 ^d	102
Methyl D-galacturonoside methyl esters	CH ₃ OH ^a	65	35.7	16.7	11.5	36.1	103
D-Galactose	Pyridine ^a	?	32.5	53.5	Not detected	14.5	104
D-Ribose	D ₂ O ^c	35	20	56	6	18	105

^a Analysis by glpc. ^b Analysis by column chromatography. ^c Analysis by nmr. ^d The presence of so much of this isomer is surprising in view of the absence of methyl β -D-lyxofuranoside in the equilibrium mixture of lyxosides. ^e Much more extensive data have recently been published for the methyl glucosides, galactosides, and mannosides^{342b} and for free sugars.^{1b}

II. Acid-Catalyzed Hydrolysis of Glycopyranosides^{111-113c}

A. INTERMOLECULAR CATALYSIS

1. Mechanism

In any acid-catalyzed reaction the logical sequence to follow in establishing the mechanism is to determine first the position of bond fission, then the nature of the acid catalysis (general or specific, slow or rapid proton transfer), next, if the reaction is specific acid catalyzed, the molecularity of the slow step, and finally any fine details of mechanism not resolved under the previous headings. The evidence obtained on these points will therefore be discussed in this order.

The position of bond fission has been determined with several glycopyranosides by performing the hydrolysis in ¹⁸O-enriched water and determining the ¹⁸O content of the resulting alcohol or phenol. Methyl and phenyl α - and β -D-glucopyranoside, maltose, and methyl 2-deoxy- α -D-glucopyranoside^{114,115} have been shown in this way to react exclusively with glucosyl-oxygen fission and ferrocenylmethyl β -D-glucopyranoside¹¹⁶ predominantly in this way (see, how-

ever, section II.A.2), but *t*-butyl β -D-glucopyranoside reacts with *t*-butyl-oxygen fission (see section II.A.2).¹¹⁵

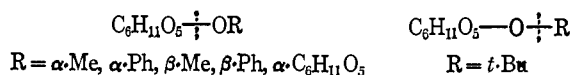

Although there is no direct evidence to indicate if these reactions are general- or specific-acid catalyzed, the solvent deuterium isotope effect has been measured for the hydrolysis of methyl α -D-glucopyranoside¹¹⁷ and methyl 2-deoxy- α -D-glucopyranoside,¹¹⁵ and the values of $k_{\text{D}_2\text{O}}/k_{\text{H}_2\text{O}}$ obtained (see Table VI) are of the magnitude usually associated with specific acid catalysis and indicate an initial, rapid, reversible proton transfer. Evidence that the subsequent slow step is a unimolecular one is given by values of the entropy of activation which have been determined with a large number of glycopyranosides^{115, 117-119} and are all strongly positive (see Tables VIII, X, XIII-XV) and from the volume of activation for the hydrolysis of methyl α -D-glucopyranoside which is +5.1 cm³ mole⁻¹ in 0.518 M HClO₄ at 100°. ¹²⁰ The dependence of the rate on acidity also supports this view.¹¹⁴ The plots of log k_{obsd} against H_0 give straight line with slopes in the range 0.89-1.04 while the corresponding plots of log k_{obsd} against log C_{H^+} are curves. However, in view of the dubious validity of the Hammett-Zucker hypothesis, these results would not in themselves be sufficient evidence for an A1 mechanism, but it

(111) M. S. Feather and J. F. Harris, *J. Org. Chem.*, **30**, 153 (1965).

(112) P. Nuhn and G. Wagner, *Pharmazie*, **21**, 261 (1966).

(113) (a) C. A. Vernon, *Proc. Roy. Soc.*, B167, 389 (1967); (b) J. Szejtli, *Staerke*, **19**, 145 (1967); *Acta Chim. Acad. Sci. Hung.*, **56**, 175 (1968); (c) J. N. BeMiller, *Advan. Carbohydr. Chem.*, **22**, 25 (1967).

(114) C. A. Bunton, T. A. Lewis, D. R. Llewellyn, and C. A. Vernon, *J. Chem. Soc.*, 4419 (1955).

(115) C. Armour, C. A. Bunton, S. Patai, L. H. Selman, and C. A. Vernon, *ibid.*, 412 (1961).

(116) A. N. de Belder, E. J. Bourne, and J. B. Pridham, *ibid.*, 4464 (1961).

(117) W. G. Overend, C. W. Rees, and J. S. Sequeira, *ibid.*, 3429 (1962).

(118) B. Capon and W. G. Overend, *Advan. Carbohydr. Chem.*, **15**, 11 (1960).

(119) T. E. Timell, *Can. J. Chem.*, **42**, 1456 (1964).

(120) R. J. Withey and E. Whalley, *ibid.*, **41**, 1849 (1963).

Table VI
Solvent Isotope Effect for the Acid-Catalyzed Hydrolysis of Some Glycosides

Glycoside	Acid	Temp., °C	k_{D_2O}/k_{H_2O}	Ref
Methyl 2-deoxy- α -D-glucopyranoside	Perchloric acid (1.2 M)	44.6	2.5	115
Methyl α -D-glucopyranoside	Hydrochloric acid (2.0 M)	59.2	1.9	117
Methyl α -D-glucopyranoside	Hydrochloric acid (2.0 M)	70.6	1.8	117

is at least reassuring that they do not conflict with the conclusions based on the values of ΔS^\ddagger and ΔV^\ddagger .

Bunnett plots for the hydrolyses of pyranosides yield apparently conflicting results. The plots for the hydrolyses of glucopyranosides in aqueous perchloric acid are straight lines with positive slopes ($w = 1.7$ – 3.0) which suggest that there is nucleophilic attack by water,^{121a} but the plots for the hydrolyses of methyl α -D-glucopyranoside and a large series of alkyl xylopyranosides in hydrochloric acid are curves with negative slopes.^{121b} Although the values of ΔS^\ddagger and ΔV^\ddagger make it difficult to accept that the mechanism is A2, the results for the hydrolyses in perchloric acid may mean that mechanism lies close to the borderline between A1 and A2. An important factor here could be that the electron-withdrawing inductive effects of the hydroxyl groups facilitate nucleophilic attack, and it is perhaps significant that the hydrolyses of the methyl 2-deoxy-D-glucopyranosides in perchloric acid have w values (-1.6 and -1.8) characteristic of the A1 mechanism. Some support for this interpretation also comes from the work of Buncel and Bradley who showed that replacement of the hydroxyl substituent at C(2) of methyl β -D-glucopyranoside by the more strongly electron-withdrawing chloro is accompanied by a decrease in the entropy of activation for hydrolysis in hydrochloric acid from $+16.5$ to $+7.5$ eu. The w value for the chloroglucoside is -0.2 , however, characteristic of an A1 mechanism.¹²²

Since glycosides are unsymmetrical acetals two mechanisms, differing in the carbon–oxygen bond broken in the rate-determining step, are consistent with the evidence already presented. These are shown for methyl α -D-glucopyranoside (eq 1 and 2). Equation 1 involves ring opening to give an acyclic hemiacetal which undergoes subsequent rapid hydrolysis while eq 2 involves loss of the methoxyl group in the rate-determining step with the formation of a cyclic carbonium ion. Evidence that the hydrolysis of methyl α -D-glucopyranoside follows the latter mechanism is given by the observation that there is an oxygen isotope effect associated with the oxygen of the methoxyl group.¹²³ This was measured by comparing the ¹⁸O content of the methanol formed after 7 and 100% hydrolysis, and the result obtained indicated that $k_{16}/k_{18} = 1.03$. An isotope effect of this magnitude would only be expected if the methoxyl–glucosyl bond was broken in the rate-determining step.^{123a}

(121) (a) J. F. Bunnett, *J. Amer. Chem. Soc.*, **83**, 4978 (1961); (b) C. K. De Bruyne and F. Van Wyendaele, *Carbohydr. Res.*, **6**, 367 (1968).

(122) E. Buncel and P. R. Bradley, *Can. J. Chem.*, **45**, 515 (1967).

(123) (a) B. E. C. Banks, Y. Meinwald, A. J. Rhind-Tutt, I. Sheft, and C. A. Vernon, *J. Chem. Soc.*, 3240 (1961). (b) The argument has been advanced (ref 70) that the "reverse anomeric effect" would make formation of the conjugate acid protonated on the methoxyl oxygen especially favored with the β -glucoside and unfavored with the α -glucoside and that the most likely mechanism for hydrolysis of the former is therefore *via* the cyclic ion and for the hydrolysis of the latter *via* ring opening. The results given in ref 123a show that this conclusion is incorrect, however, and that the α -D-glucosylpyridinium ion is not a good model for the transition state for the hydrolysis of the methyl α -D-glucoside *via* a cyclic ion.

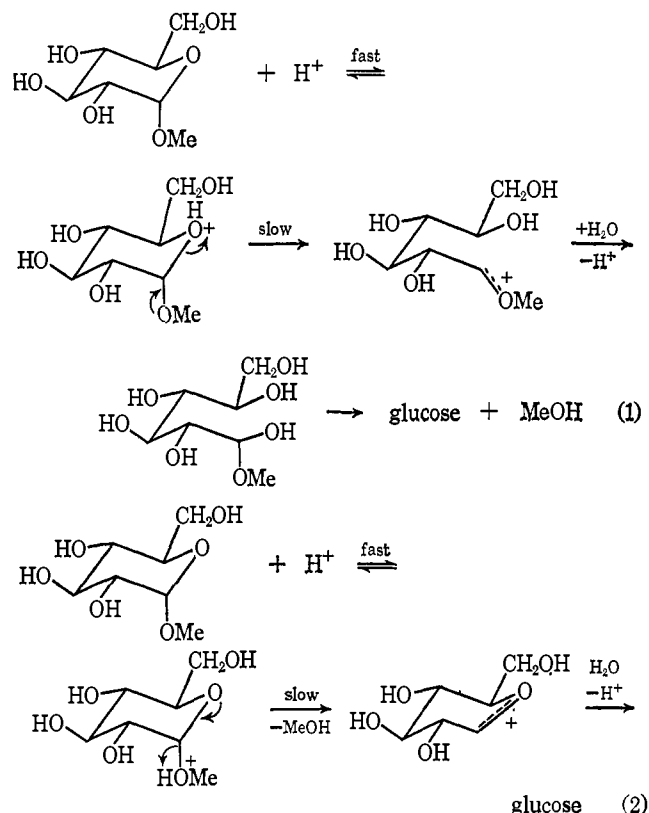

It is of interest that the intermediate cyclic carbonium ion is not captured exclusively by water, but there is some formation of disaccharides through capture by other molecules of the glucoside or glucose; 5–10% of the product results from this reaction when the initial concentration of the glucoside is 0.1 M.¹¹⁷ Addition of 0.1 M glucose to the reaction mixture causes twice this amount to be formed without altering the over-all rate of reaction, as would be expected if the reaction involved the rapid capture of the carbonium ion after the rate-determining step.

Although it is not known for certain if the mechanism of eq 2 is also followed in the hydrolysis of other glucopyranosides, it seems reasonable that this should be so. With aryl glucosides, for instance, any part of the reaction occurring *via* the acyclic ion would be expected to proceed more slowly than with methyl glucoside, since ion 44 should be less stable than ion 45.

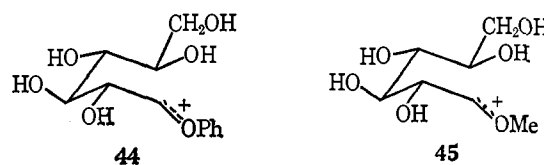

Phenyl α -D-glucoside is hydrolyzed more rapidly than methyl α -D-glucoside, however (see Table XX). This is con-

sistent with the mechanism involving the rate-determining formation of a cyclic ion since replacing the methoxyl group by a phenoxyl group should lead to a decrease in the standing concentration of conjugate acid but an increase in its rate of heterolysis, and hence possibly in a net rate increase (for a further discussion of this point see section II.A.2). The position is similar with disaccharides. Here the aglycon carries several electron-withdrawing substituents which would destabilize an acyclic carbonium ion and the transition state for its formation but have a much smaller effect on the stability of the transition state for the formation of the cyclic ion because of the opposed electronic requirements of protonation and heterolysis.

It is much more difficult to decide if there is a change in mechanism on going from glucopyranosides to pyranosides of other sugars. It might be expected that ring opening would occur more rapidly with sugars in which two or three substituents are constrained to take up axial positions but with these glycosides movement toward the preferred half-chair conformation of the cyclic ion should also be favored. With our present knowledge it is impossible to say whether the former effect would be sufficiently greater than the latter to cause a change in mechanism (see also section VI.C). In the following discussion of the effect of the structure on reactivity, the mechanism of eq 2 will be assumed to be followed by other glycosides, but it should be remembered that generally a mechanism involving a rate-determining ring opening has not been rigorously excluded.

2. Structure and Reactivity

The effect of substituents in the aglycon on the rate of hydrolysis of aryl glucosides has been shown by Rydon and his coworkers to be very slight (see Table VII), the ρ values being -0.006 and -0.66 for the α and β series, respectively^{124,125}

Table VII

First-Order Rate Constants for the Acid-Catalyzed Hydrolysis of Some Substituted Phenyl D-Glucopyranosides in 0.1 M Hydrochloric Acid^{124,125}

Substituent	$10^6 k$ (sec ⁻¹) for α -glucosides at 70°	$10^6 k$ (sec ⁻¹) for β -glucosides at 60°
None	19.5	1.92
<i>o</i> -Me	12.8	1.81
<i>m</i> -Me	19.2	2.34
<i>p</i> -Me	15.3	3.87
<i>o</i> -MeO	...	14.9
<i>m</i> -MeO	20.3	1.28
<i>p</i> -MeO	17.8	4.01
<i>o</i> -Cl	...	2.88
<i>m</i> -Cl	20.0	1.27
<i>p</i> -Cl	9.7	1.38
<i>m</i> -CN	...	8.48
<i>p</i> -CN	...	0.610
<i>o</i> -NO ₂	...	2.77
<i>m</i> -NO ₂	15.2	0.673
<i>p</i> -NO ₂	16.8	0.550

(124) R. L. Nath and H. N. Rydon, *Biochem. J.*, **57**, 1 (1954).

(125) A. N. Hall, S. Hollinghead, and H. N. Rydon, *J. Chem. Soc.*, 4290 (1961).

(126) (a) B. N. Stepanenko and O. G. Serdyuk, *Dokl. Akad. Nauk SSSR*, **139**, 1132 (1961); (b) M. D. Saunders and T. E. Timell, *Carbohydr. Res.*, **5**, 453 (1967); see also E. Tomita, *Yakugaku Zasshi*, **87**, 485 (1967).

(see also ref 126a). These results are consistent with a mechanism involving a cyclic carbonium ion (see eq 3) since the measured rate constant is a product of the equilibrium constant

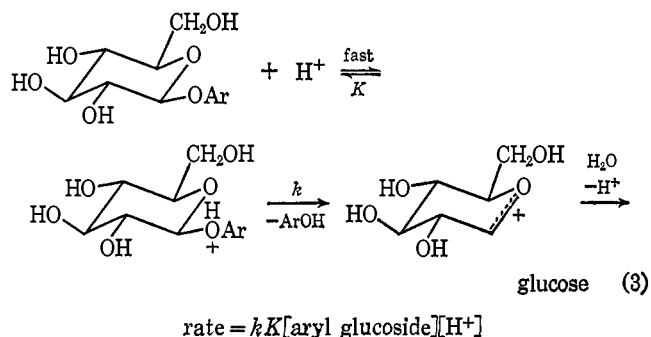

for protonation, K , and the rate constant, k , for the unimolecular heterolysis, and the effect of substituents on these would be expected to be in opposite senses and hence to tend to cancel. The more positive ρ value for the α series suggests that carbonium ion character is more highly developed in the transition states for this series than for the β series.

Substituents in the methyl group of methyl β -D-glucopyranoside¹¹⁹ and β -D-xylopyranoside^{121b} also have only a small effect on the rate of hydrolysis (see Table VIII), but with methyl β -D-glucopyranosiduronic acids the effect is larger and in the opposite sense.^{120b} With the methyl glucosides and xylosides electron-withdrawing substituents are very slightly rate enhancing, but with the glucopyranosiduronic acids they are rate decreasing and the effect is larger. Interpretation is complicated since the forms of the glucopyranosiduronic acids with the carboxyl group ionized and un-ionized are probably undergoing hydrolysis simultaneously (see below). The results (Table VIII) suggest, however, that with the glucopyranosiduronic acids the equilibrium constant for protonation of the glycosidic oxygen is more sensitive to substituent effects than the rate constant for heterolysis of the conjugate acid, and that the reverse is true for the glucosides. It is not clear why there should be this difference. Carboxymethyl β -D-glucopyranosiduronic acid is hydrolyzed about 100 times faster than calculated from the plot of $\log k$ against σ^* for the other glucopyranosiduronic acids and the σ^* constant of the carboxyl group and it was suggested that the reaction involves intramolecular catalysis (*cf.* section II.B).

t-Butyl, 2-methylbut-2-yl, and triethylmethyl β -D-glucopyranoside react at greatly enhanced rates^{115, 119, 128} (see Tables IX and X) but by a different mechanism involving formation of the tertiary alkyl cation, as shown by tracer experiment with the *t*-butyl compound (see section II.A.1) and the positive entropies of activation. The greater rate for the triethylmethyl compound may be the result of steric acceleration.

The acid-catalyzed hydrolysis of ferrocenylmethyl β -D-glucopyranoside proceeds 10^4 – 10^5 times more rapidly than that of phenyl β -D-glucoside¹¹⁶ which in view of the high stability of the ferrocenylmethyl cation suggests that the reaction proceeds with ferrocenylmethyl–oxygen fission, especially as *t*-butyl β -D-glucoside which would yield the less stable *t*-butyl cation has been shown to react with *t*-butyl–oxygen fission. It was claimed,¹¹⁶ however, that the reaction involved 75% glucosyl–oxygen fission which is surprising since struc-

(127) S. Veibel and S. Frederiksen, *Kgl. Danske Videnskab. Selskab, Mat-Fys. Medd.*, **19**, No. 1 (1941).

(128) S. Veibel and E. Hjorth, *Acta Chem. Scand.*, **6**, 1353 (1952).

Table VIII

First-Order Rate Constants and Kinetic Parameters for the Acid-Catalyzed Hydrolyses of Some Substituted Methyl β -D-Glucopyranosides ($XCH_2-O-C_6H_4O_5$) and Some Substituted Methyl β -D-Glucopyranosiduronic Acids ($XCH_2-O-C_6H_4O_6$) in 0.5 M Sulfuric Acid at 60°¹¹⁹

Substituent X	Glucopyranosides			Glucopyranosiduronic acids		
	10^6k_1 , sec ⁻¹	E_{a1} , kcal mole ⁻¹	ΔS^\ddagger , cal deg ⁻¹ mole ⁻¹	10^6k_1 , sec ⁻¹	E_{a1} , kcal mole ⁻¹	ΔS^\ddagger , cal deg ⁻¹ mole ⁻¹
H	1.38	32.5	+10.6	1.16	29.3	+0.8
HO ₂ C	4.11	31.4	+9.5	0.317	32.1	+6.4
Me	1.54	33.8	+14.8	3.91	28.8	+1.5
HO ₂ CCH ₂	1.58	33.1	+12.7
HOCH ₂	1.73	33.6	+14.4	0.614	30.5	+3.0
MeOCH ₂	1.83	33.9	+15.4	0.65	28.7	-2.3
ClCH ₂	2.21	32.7	+12.4	0.183	31.1	+2.5
Et	1.82	32.9	+12.4	4.54	29.0	+2.5
HOCH ₂ CH ₂	1.24	34.4	+16.1

Table IX

First-Order Rate Constants^a for the Acid-Catalyzed Hydrolysis of Some Alkyl β -D-Glucopyranosides in 1 M Aqueous Hydrochloric Acid^{127,128}

Alkyl group	10^6k_1 , sec ⁻¹		
	60°	50°	40°
Methyl	3.5
Propyl	4.6
Isopropyl	7.9
Pent-3-yl	11.7	2.8	...
<i>t</i> -Butyl	...	447	105
2-Methylbut-2-yl	428
Neopentyl	6.7

^a In this and several subsequent tables the values of the rate constants quoted in the original papers, calculated with logarithms to base 10, have been converted to true rate constants based on logarithms to base *e* in accord with the definition of a first-order rate constant, $dx/dt = k(a - x)$. Also the units have usually been converted to sec⁻¹.

tural variation of the aglycon generally has only minor effects on the rate of the acid-catalyzed hydrolysis of glycosides involving glycosyl-oxygen fission. A reinvestigation of this reaction would therefore be of interest.

Neighboring group participation apart (*cf.* section II.B), substituents in the sugar part of glycosides may influence the rate of hydrolysis by electronic effects and sterically. The major effect of substituents at position 2 is electronic, and quite large effects are observed (Table XI) since the substituents influence the equilibrium constant for protonation and the rate constant for the decomposition of the conjugate acid in the same sense. It has been claimed that a plot of the logarithm of the rate constant for the hydrolysis at 72.9° of a series of methyl 2-deoxy-D-glucosides with different substituents on carbon 2 against the logarithm of the dissociation constant of the corresponding acid, XCH_2CO_2H , is a straight line.¹²⁹ The data in Table XI^{130,131} show, however, that this correlation cannot be very good since the hydrolysis of methyl 2-acetamido-2-deoxy- β -D-glucoside is faster than that of methyl β -D-glucoside despite the σ_1 constant for the $-NHCOCH_3$ group being larger

(129) R. D. Marshall, *Nature*, 199, 998 (1963).(130) R. C. G. Moggridge and A. Neuberger, *J. Chem. Soc.*, 745 (1938).(131) K. Onodera and T. Komano, *Agr. Biol. Chem.* (Tokyo), 25, 932 (1961).

Table X

First-Order Rate Constants and Kinetic Parameters for the Acid-Catalyzed Hydrolysis of Some Alkyl β -D-Glucopyranosides in Aqueous Sulfuric Acid¹¹⁹

Alkyl group	10^6k_1	10^6k_1	E_{a1} , kcal mole ⁻¹	ΔS^\ddagger , cal deg ⁻¹ mole ⁻¹
	(sec ⁻¹) in 0.5 M H ₂ SO ₄ at 60°	(sec ⁻¹) in 0.01 M H ₂ SO ₄ at 60°		
Methyl	1.38	...	32.5	+10.6
Ethyl	1.54	...	33.8	+14.8
Isopropyl	2.65	...	33.2	+14.0
<i>t</i> -Butyl	767	7.56	30.4	+16.9
Triethylmethyl	...	422
Propyl	1.82	...	32.9	+15.1
<i>n</i> -Butyl	1.62	...	33.6	+14.3
Isobutyl	1.90	...	33.8	+15.2
Neopentyl	2.41	...	36.2	+22.9
Cyclohexyl	3.25	...	33.5	+15.3
Benzyl	1.56	...	33.6	+14.2
Allyl	1.83	...	33.8	+15.1

Table XI

First-Order Rate Constants for the Hydrolysis of Methyl 2-Deoxy- β -D-Glucosides with Different Substituents at Position 2 in Hydrochloric Acid

Substituent	10^6k_1 , sec ⁻¹	[HCl], M	Temp, °C	$10^6k_1^a$	σ_1	Ref
H	63.6	0.10	60.5	1480	0	117
OH	0.859	2.0	61.2	0.708	0.25	117
NH ₃ ⁺	0.0585	2.5	80.0	0.005	0.60	130, 131
NHCOCH ₃	1.25	1.0	61.25	4.0	0.28	130, 131

^a Extrapolated to 2 M HCl and 60°.

than that of the $-OH$ group, and it has been shown recently that the former compound reacts with participation by the amido group (see ref 297b below). Bearing this objection in mind and also the difference of solvent and temperature, it is, nevertheless, tempting to compare the ρ^* value obtained, -2.34 , with that for the hydrolysis of the acetals, $XCH_2-CH(OEt)_2$, in a mixture of dioxane (49.6%) and water (50.4%) at 25° which was -3.65 .¹³² One may then speculate that part

(132) M. M. Kreevoy and R. W. Taft, *J. Amer. Chem. Soc.*, 77, 5590 (1955).

of the difference is the result of there being less carbonium ion character in the transition state for the hydrolysis of the glycosides than in that for the acetals. This speculation is consistent with the explanation of the abnormal ν values for glycoside hydrolysis given above (ref 121), that the transition state lies nearer to the A2 end of the spectrum of possible A1 structures than does that for the hydrolysis of simple acetals.

A comparable rate-enhancing effect to that found on replacing the hydroxyl at C(2) by hydrogen, in the 2-deoxy-glucosides, is found in the hydrolysis of 2-methoxytetrahydropyran which proceeds 1100 times faster than that of a 3-hydroxy-2-methoxytetrahydropyran of unspecified configuration.¹³³

Substituents at C(3) and C(4) have smaller but still appreciable effects (Table XII). The greater rate for methyl 4-deoxy- α -D-glucoside compared to methyl 3-deoxy- α -D-glucoside indicates that the relative rates cannot be determined solely by

Table XII

First-Order Rate Constants for the Acid-Catalyzed Hydrolysis of Some Methyl Deoxy- α -D-glucopyranosides in 2 M Hydrochloric Acid at 58.1^o¹¹⁷

Glycoside	10^6k , sec^{-1}
Methyl α -D-glucopyranoside	0.52 ^a
Methyl 2-deoxy- α -D-glucopyranoside	1100 ^a
Methyl 3-deoxy- α -D-glucopyranoside	10.4
Methyl 4-deoxy- α -D-glucopyranoside	21.2

^a Extrapolated values.

the polar effects of the substituents and presumably steric effects of the kind outlined below are a contributing factor.¹¹⁷

The effect of substituents at C(5) on the rate of hydrolysis of glycosides has also been determined (Tables XIII^{134, 135} and XIV). The first-order rate constants cannot be correlated

Table XIII

First-Order Rate Constants and Activation Parameters for the Hydrolysis of 6-Substituted Methyl α -D-Glucopyranosides in 0.5 M Sulfuric Acid^{134, 135}

Glycoside	10^6k at 60°, sec^{-1}	E_a , kcal mole^{-1}	ΔS^\ddagger
Methyl α -D-glucoside	0.637	35.1	+16.9
Methyl α -D-glucopyranosiduronic acid	0.572	30.2	+2.0
Methyl α -D-xyloside	3.06	33.4	+14.9
Methyl 6-deoxy- α -D-glucoside	3.22	34.6	+18.6
Methyl 6-deoxy-6-iodo- α -D-glucoside	0.099	34.2	+10.5
Methyl 6-deoxy-6-chloro- α -D-glucoside	0.092	35.7	+14.9
Methyl 6-deoxy-6-amino- α -D-glucoside	0.065	33.0	+6.1
Methyl 6-O-methyl- α -D-glucoside	0.449	34.2	+13.5

(133) E. Dyer, C. P. J. Glaudemans, M. J. Koch, and R. H. Marchessault, *J. Chem. Soc.*, 3361 (1962).

(134) T. E. Timell, *Chem. Ind.* (London), 503 (1964).

(135) T. E. Timell, W. Enterman, F. Spencer, and E. J. Soltes, *Can. J. Chem.*, 43, 2296 (1965).

Table XIV

First-Order Rate Constants and Activation Parameters for the Hydrolysis of 6-Substituted Methyl β -D-Glucopyranosides in 0.5 M Sulfuric Acid¹³⁵

Glycoside	10^6k at 60°, sec^{-1}	E_a , kcal mole^{-1}	ΔS^\ddagger , eu
Methyl β -D-xyloside	6.56	33.9	+17.9
Methyl β -D-glucoside	1.38	32.5	+10.6
Methyl β -D-glucopyranosiduronic acid	1.16	29.3	+0.8
Methyl 6-O-methyl- β -D-glucoside	0.840	34.9	+16.8
Methyl 6-O-ethyl- β -D-glucoside	1.01	34.4	+15.8
Methyl 6-O-isopropyl- β -D-glucoside	1.11	34.8	+17.1

with the polar effects of the substituents. In particular, it was noted that methyl β -D-glucopyranosiduronic acid (46) reacts

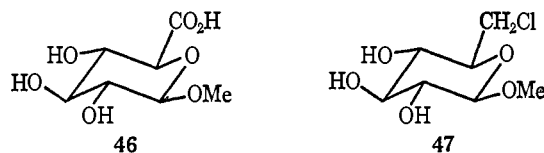

about five times more rapidly than methyl 6-chloro-6-deoxy- β -D-glucoside (47) despite the σ^* constants of the chloromethyl and methoxycarbonyl groups being similar.¹³⁴ The rates of hydrolysis of a large number of alkyl and aryl glucopyranosiduronic acids have been measured in 0.5 to 1.0 M sulfuric acid and entropies and enthalpies of activation calculated (see Tables XIII–XVII)^{135–138} (see also ref 139–141). It was found

Table XV

First-Order Rate Constants and Activation Parameters^a for the Hydrolysis of Alkyl β -D-Glucopyranosiduronic Acids and the Corresponding β -D-Glucopyranosides in 0.5 M Sulfuric Acid¹³⁵

Glycoside	10^6k at 60°, sec^{-1}	E_a , ^a kcal mole^{-1}	ΔS^\ddagger , ^a eu
Isopropyl β -D-glucoside	2.65	33.2	+14.0
Isopropyl β -D-glucuronide	4.87	28.3	+0.5
<i>n</i> -Butyl β -D-glucoside	1.62	33.6	+14.3
<i>n</i> -Butyl β -D-glucuronide	4.20	29.3	+3.3
Isobutyl β -D-glucoside	1.90	33.8	+15.2
Isobutyl β -D-glucuronide	3.74	29.5	+3.7
Neopentyl β -D-glucoside	2.41	36.2	+22.9
Neopentyl β -D-glucuronide	4.65	30.0	+5.6
Cyclohexyl β -D-glucoside	3.25	33.5	+15.3
Cyclohexyl β -D-glucuronide	18.5	28.7	+4.5
Benzyl β -D-glucoside	1.56	33.6	+14.2
Benzyl β -D-glucuronide	0.587	30.9	+4.1

^a See text.

(136) D. B. Easty, *J. Org. Chem.*, 27, 2102 (1962).

(137) L. K. Semke, N. S. Thompson, and D. G. Williams, *ibid.*, 29, 1041 (1964).

(138) K. K. De and T. E. Timell, *Carbohydr. Res.*, 4, 177 (1967).

(139) R. L. Whistler and G. N. Richards, *J. Amer. Chem. Soc.*, 80, 4888 (1958).

(140) I. Johansson, B. Lindberg, and O. Theander, *Acta Chem. Scand.*, 17, 2019 (1963).

(141) C. A. Marsh in "Glucuronic Acid," G. J. Dutton, Ed., Academic Press, New York, N. Y., 1966, p 71.

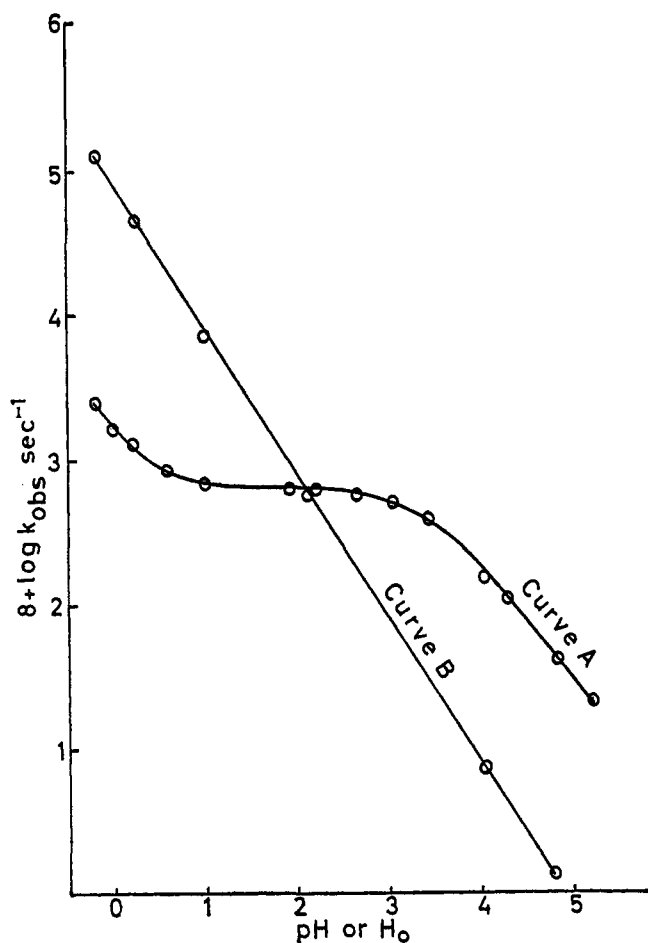

Figure 1. Plot of $\log k_{\text{obs}}$ vs. pH or H_0 for the hydrolysis of 2-naphthyl- β -D-glucopyranosiduronic acid (curve A) and 2-naphthyl- β -D-glucoside (curve B) at 90.1°.

that generally the glucopyranosiduronic acids reacted more slowly than the corresponding glycosides although in 0.5 *M* sulfuric acid at 60 and 70° methyl α -D-mannopyranosiduronic acid reacts 2.5 and 1.5 times faster than methyl α -D-mannoside, and under similar conditions isopropyl, *n*-butyl, isobutyl, neopentyl, and cyclohexyl β -D-glucopyranosiduronic acid react up to about 5.5 times faster than the corresponding glucopyranosides.¹³⁵ Some doubt has been thrown on the validity of this approach, however, by the observation¹⁴² that even in strong acid the hydrolysis of both the ionized and un-ionized 2-naphthyl β -D-glucopyranosiduronic acid contribute to the total rate. If this is also the case for the glucopyranosiduronic acids studied earlier, the enthalpies and entropies of activation determined from the measured first-order rate constants will be a function of the enthalpies and entropies of activation of the hydrolysis of the ionized and un-ionized forms and the enthalpy and entropy of ionization of the carbonyl group and not easily interpretable.

The hydrolysis of 2-naphthyl β -D-glucopyranosiduronic acid was shown to follow a rate law: rate = k_1 [un-ionized form] + k_2 [un-ionized form] h_0 with $k_1 = 7.1 \times 10^{-6} \text{ sec}^{-1}$ and $k_2 = 1.2 \times 10^{-5} \text{ l. mole}^{-1} \text{ sec}^{-1}$ at 90.1° (see Figure 1).¹⁴² The first term on the right-hand side of this equation was interpreted as resulting from a specific hydrogen-ion catalyzed reaction of the ionized form of the glucopyranosiduronic acid. The second-

(142) B. Capon and B. C. Ghosh, *Chem. Commun.*, 586 (1965).

Table XVI

First-Order Rate Constants and Activation Parameters^a for the Hydrolysis of Some Aryl β -D-Glucopyranosiduronic Acids and β -D-Glucosides in 1 *M* Sulfuric Acid¹³⁷

Aryl	$10^5 k$ at 59.95° ^b		$10^5 k$ at 59.90° ^b		ΔS^\ddagger	
	min^{-1}	ΔH^\ddagger	min^{-1}	ΔH^\ddagger	$\text{cal}^\circ\text{C}^{-1}$	eu°
Phenyl	6.11	32.2	144	29.9	+10.1	+10
<i>p</i> -Chloro-phenyl	5.82	32.4	110	30.1	+11.1	+9
<i>p</i> -Methyl phenyl	5.48	32.3	170	30.3	+10.2	+11

^a See text. ^b Calculated from the isotherm coefficients reported in ref 137.

Table XVII

First-Order Rate Constants and Activation Parameters^a for the Hydrolysis of Some Methyl Glucopyranosiduronic Acids and the Corresponding Methyl Glucopyranosides in 0.5 *M* Sulfuric Acid¹³⁵

Glycosides	$10^5 k$ at 60°, sec^{-1}	E^\ddagger	ΔS^\ddagger
Methyl α -D-galactoside	3.04	34.0	+16.7
Methyl α -D-galactopyranosiduronic acid	2.87	31.1	+8.0
Methyl β -D-galactoside	5.87	32.0	+12.0
Methyl β -D-galactopyranosiduronic acid	0.852	32.2	+8.8
Methyl α -D-mannoside	1.45	34.7	+17.3
Methyl α -D-mannopyranosiduronic acid	3.72	31.0	+8.1

^a See text.

order rate constant for this reaction, k^* , is related to k_1 by the equation $k^* = k_1/K_a$, where K_a is the dissociation constant of the glucopyranosiduronic acid. The relative rates of hydrolysis of ionized and un-ionized glucopyranosiduronic acid are then 1580:1. This means that in *M*/2 acid, although only $1/1580$ th of the glucopyranosiduronic acid is present in its ionized form ($K_a = 3.6 \times 10^{-4} \text{ mole l.}^{-1}$), about half of the measured rate of hydrolysis is attributable to this because of its greater rate constant. It is also of interest that since the hydrolysis of 2-naphthyl β -D-glucoside follows a rate law, rate = k [glucoside] h_0 (see Figure 1), there is an inversion in the relative rates of hydrolysis with acidity. In 1 *M* hydrochloric acid the glucoside reacts 45 times faster than the glucopyranosiduronic acid, but at pH 4.79 it reacts 35 times slower. These results suggest that it may be possible to hydrolyze polysaccharides containing uronic acid residues preferentially at the uronoside linkage by carrying out the reaction in solutions of low acidity. A similar dependence on acidity has in fact been found for the rate of hydrolysis of a polysaccharide containing uronic acid residues.¹⁴³ The rates of hydrolyses of several other glucopyranosiduronic acids in moderately concentrated acidic solutions are correlated by H_0 , but they were not measured at acidities lower than that of 0.25 *M* sulfuric acid.^{144a}

(143) O. Smidsrød, A. Haug, and B. Larsen, *Acta Chem. Scand.*, 20, 1026 (1966); *Carbohydr. Res.*, 5, 371 (1967); see also N. Roy and T. E. Timell, *ibid.*, 7, 17 (1968).

(144) (a) E. Tomita, Y. Hirota, and Y. Nitta, *Yakugaku Zasshi*, 87, 479 (1967); (b) O. Theander, *Acta Chem. Scand.*, 18, 1297 (1964).

When the primary hydroxyl group at C(6) of methyl β -D-glucoside is replaced by an aldehyde group, the rate of hydrolysis is increased by a factor of 15–20.^{144b} This is the opposite of what would be expected on the basis of the aldehyde (or *gem*-diol) group being more strongly electron withdrawing than the hydroxymethylene group. It was suggested that the aldehyde compound exists appreciably in an internal hemi-

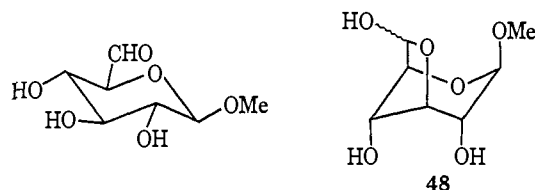

acetal form with the alternative conformation (48) similar to that of the highly acid-sensitive 3,6-anhydropyranosides. Support for this suggestion was obtained by the observation that electrophoretic mobility in borate buffer of the aldehyde compound was almost as great as that of methyl 3,6-anhydro- β -D-glucopyranoside.

Introduction of a sulfate ester group at position 6 of methyl β -D-galactoside results in an eightfold decrease in the rate of hydrolysis,¹⁴⁵ and of a nitrate ester group at position 6 of methyl β -D-glucoside in a fivefold decrease.¹⁴⁶

Methylating one hydroxyl group of methyl and *p*-nitrophenyl β -D-glucoside has only a slight effect on the rates of hydrolysis.¹⁴⁷ At the temperatures studied this is rate-decreasing for methyl β -D-glucoside whatever the position of methylation (see Table XVIII).^{147a,b} In contrast, isopropylation of

Table XVIII

First-Order Rate Constants and Activation Parameters for the Hydrolysis of Methyl Mono-*O*-methyl- β -D-glucopyranosides in 0.5 M Sulfuric Acid^{147a}

Compound	$10^3k, \text{sec}^{-1}$			$E, \text{kcal mole}^{-1}$	$\Delta S^\ddagger, \text{at } 60^\circ, \text{eu}$
	60°	70°	80°		
2- <i>O</i> -Methyl	1.19	5.22	20.8	33.4	+13.8
3- <i>O</i> -Methyl	1.27	5.66	23.8	34.2	+16.4
4- <i>O</i> -Methyl	1.15	4.97	21.2	34.0	+15.6
6- <i>O</i> -Methyl	0.84	3.88	16.1	34.5	+16.4
Unsubstituted	1.38	6.25	24.1	33.4	+14.1

^a Calculated by the reviewer.

O(2), O(3), or O(4) increases the rate of hydrolysis of methyl α - and β -D-glucoside at the temperatures studied, but again the effects are very slight (Table XIX).¹⁴⁸ In the reviewer's opinion they are much too small to allow any conclusions to be made concerning the mechanism.

Methyl tetra-*O*-methyl- α -D-glucoside, - β -D-glucoside, - α -D-mannoside, and - α -D-galactoside are hydrolyzed two to six times more slowly than the corresponding unmethylated glycosides¹⁴⁹ (see, however, ref 150 where methyl tetra-*O*-

(145) M. J. Clancy and J. R. Turvey, *J. Chem. Soc.*, 2935 (1961).

(146) B. Lindberg and S. Svensson, *Acta Chem. Scand.*, 21, 299 (1967).

(147) (a) K. K. De and T. E. Timell, *Carbohydr. Res.*, 4, 72 (1967); (b) M. D. Saunders and T. E. Timell, *ibid.*, 6, 12 (1968); (c) M. A. Jermy, *Aust. J. Chem.*, 12, 528 (1959).

(148) J. E. Hook and B. Lindberg, *Acta Chem. Scand.*, 20, 2363 (1966); see also *ibid.*, 22, 921 (1968).

(149) W. N. Haworth, *Ber.*, 65A, 50 (1932).

(150) E. A. Moelwyn-Hughes, *Trans. Faraday Soc.*, 25, 81 (1929).

Table XIX

First-Order Rate Constants and Activation Parameters for the Hydrolysis of Methyl *O*-Isopropyl- β -D-glucopyranosides in 0.5 M Sulfuric Acid

Compound	$10^3k, \text{sec}^{-1}$			$E, \text{kcal mole}^{-1}$	$\Delta S^\ddagger, \text{at } 80^\circ, \text{eu}$
	70°	80°	93.0°		
α Series					
2- <i>O</i> -Isopropyl	3.38	16.1	94.4	34.9	16.8
3- <i>O</i> -Isopropyl	3.57	18.4	100.0	34.5	15.8
4- <i>O</i> -Isopropyl	2.94	14.1	85.5	35.5	17.8
6- <i>O</i> -Isopropyl	2.30	10.7	64.4	35.0	17.4
Unsubstituted	2.82	13.8	76.1	33.8	13.2
β Series					
2- <i>O</i> -Isopropyl	10.6	50.6	276.5	33.7	15.7
3- <i>O</i> -Isopropyl	10.4	46.6	248.0	33.0	13.5
4- <i>O</i> -Isopropyl	6.12	28.2	162.1	34.5	16.7
6- <i>O</i> -Isopropyl	4.26	21.4	129.1	35.4	18.6
2,3-Di- <i>O</i> -isopropyl	13.2	63.0	364.0	34.6	17.5
Unsubstituted	6.01	25.4	141.0	33.9	14.0

methyl- α -D-glucoside is reported to be hydrolyzed more rapidly than methyl glucoside).

The effects of configurational changes on the rates of hydrolyses of methyl glycosides are given in Tables XX–XXII. They can to a large extent be accounted for as resulting from

Table XX

First-Order Rate Constants and Kinetic Parameters for the Acid-Catalyzed Hydrolysis of Some Glycopyranosides in 2.0 M Hydrochloric Acid^{117,153}

Glycopyranoside	Extrapolated value of 10^3k at 60°, sec^{-1}	$E, \text{kcal mole}^{-1}$	$\Delta S^\ddagger, \text{at } 60^\circ, \text{cal deg}^{-1} \text{mole}^{-1}$
Methyl α -D-glucoside	0.708	34.4 ± 0.4	+14.8
Methyl β -D-glucoside	1.26	34.3 ± 0.4	+16.5
Phenyl α -D-glucoside	38.0	31.1 ± 2.0	+13.3
Phenyl β -D-glucoside	9.33	31.0 ± 1.2	+10.8
<i>p</i> -Nitrophenyl α -D-glucoside	25.1	30.3 ± 1.6	+10.5
<i>p</i> -Nitrophenyl β -D-glucoside	2.88	30.3 ± 1.8	+6.4
Methyl α -D-galactoside	3.55	34.0 ± 0.3	+17.7
Methyl β -D-galactoside	5.13	32.3 ± 0.6	+13.3
Ethyl α -D-galactoside	7.58	33.0 ± 1.5	+16.4
Ethyl β -D-galactoside	5.01	31.6 ± 1.0	+11.2
Phenyl α -D-galactoside	128	30.2 ± 0.4	+13.5
Phenyl β -D-galactoside	24.5	28.1 ± 0.1	+4.1
Methyl 6-deoxy- α -D-galactoside	20.0	33.9 ± 0.6	+20.8
Methyl α -D-mannoside	2.09	31.9 ± 0.4	+10.4
Methyl α -D-altroside	12.6	31.7 ± 1.0	+13.5
Methyl α -D-xyloside	2.69	33.5 ± 0.9	+15.7
Methyl β -D-xyloside	5.89	33.6 ± 0.9	+17.5
Methyl α -L-arabinoside	14.1	30.6 ± 0.4	+10.2
Methyl β -L-arabinoside	9.55	32.5 ± 0.6	+15.2
Methyl β -D-riboside	8.71	31.4 ± 0.9	+11.8
Methyl α -D-lyxoside	13.5	31.2 ± 1.0	+12.1
Maltose	5.25	32.5 ± 0.1	+16.0
Cellobiose	1.71	31.9 ± 1.1	+11.8
α, α -Trehalose	0.47	35.8 ± 0.7	+20.8

Table XXI

First-Order Rate Constants for the Hydrolysis of Some Methyl Glycopyranosides^{154a}

Methyl glycopyranoside	10^5k (sec^{-1}) in 0.05 M HCl at 98°	10^5k (sec^{-1}) in 0.5 M HCl at 75°
α -D-Lyxo-	14.4	11.0
β -D-Lyxo-	51.8	...
α -D-Manno-	2.65	1.81
β -D-Manno-	6.41	4.34
α -D-Gulo-	48.0	44.1
β -D-Gulo-	22.1	14.5
D-Glycero- α -L-glucohepto-	0.637	...
D-Glycero- α -L-mannohepto-	1.46	...
D-Glycero- β -L-mannohepto-	3.30	...
D-Glycero- α -D-gulohepto-	18.6	16.0
D-Glycero- β -D-gulohepto-	8.40	5.06

^a See footnote to Table IX.

Table XXII

First-Order Rate Constants for the Hydrolysis of Some Methyl Glycopyranosides^{155a}

Methyl glycopyranoside	10^5k (sec^{-1}) in 0.01 M HCl at 100°	10^5k (sec^{-1}) in 0.5 M HCl at 75°
α -D-Gluco-	0.25	0.76
β -D-Gluco-	0.526	1.46
α -D-Xylo-	...	3.46
β -D-Xylo-	...	6.9
α -D-Galacto-	...	3.99
β -D-Galacto-	...	7.0
α -L-Arabino-	...	6.9
β -L-Arabino-	...	10
α -L-Rhamno-	2.1	...
β -L-Rhamno-	4.8	...
α -D-Manno-	0.526	...
β -D-Manno-	0.81	...
α -D-Xylo-	4.15	...

^a See footnote to Table IX.

effects on the conformational changes accompanying the formation of the intermediate carbonium ion. This ion is stabilized through mesomeric interaction with the ring oxygen (49 \longleftrightarrow 50), and as was first pointed out by Chapman and

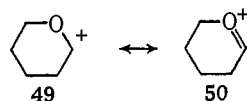

Laird¹⁵¹ such stabilization will be maximized when C(5), O(5), C(1), and C(2) all lie in one plane. Steric factors which favor the transformation of the chair conformation of the glycoside to a partially planar conformation will therefore cause an increase in reaction rate. This idea was developed by Edward¹⁵² in terms of the steric factors involved in the transformation of a glycoside in the chair conformation into a glycosyl cation in the half-chair conformation (51 \rightarrow 52). This transformation

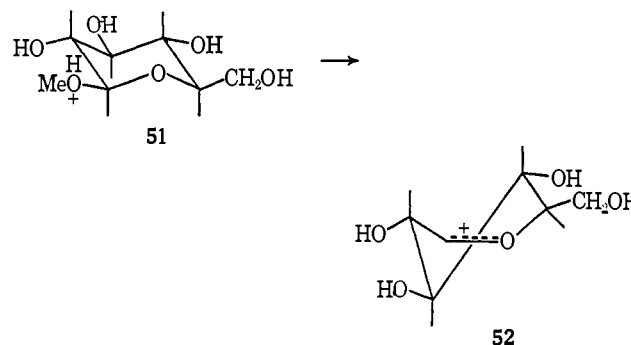

results in a recession of the C(2) and C(5) axial substituents away from the C(4) and C(3) axial substituents, respectively, and hence when these substituents are hydroxyl groups there is a greater release of nonbonded interactions than when they are hydrogens. Consequently, on comparing methyl D-glycopyranosides which differ only at C(2), C(3), and C(4) (*i.e.*, all in the normal conformation), it is predicted that the order of reactivity will be idosides (three axial hydroxyl groups) > altrosides, guloses (two axial hydroxyl groups) > allosides, mannosides, galactosides (one axial hydroxyl group) > glucosides (no axial hydroxyl groups), and lyxosides > arabinosides > ribosides > xylosides. These sequences agree with those found experimentally as shown in Tables XX–XXII.^{153–155}

Recent investigations of the kinetics of hydrolysis of glycosides are given in ref 156a.

3. Disaccharides

There have been several kinetic measurements on the hydrolysis of disaccharides, the most extensive being that of Wolfrom, Thompson, and Timberlake.^{156b} Their results for all eight 1 \rightarrow 2, 1 \rightarrow 3, 1 \rightarrow 4, and 1 \rightarrow 6 disaccharides of D-glucose are given in Table XXIII, and it is seen that the over-all variation

Table XXIII

First-Order Rate Constants for the Hydrolysis of Some D-Glucosyl D-Glucosides at 80° in 0.1 M HCl^{156b}

α -Linked compounds			β -Linked compounds		
	Linkage	10^5k , sec^{-1}		Linkage	10^5k , sec^{-1}
Kojibiose	1 \rightarrow 2	1.46	Sophorose	1 \rightarrow 2	1.17
Nigerose	1 \rightarrow 3	1.78	Laminaribiose	1 \rightarrow 3	0.99
Maltose	1 \rightarrow 4	1.55	Cellobiose	1 \rightarrow 4	0.66
Isomaltose	1 \rightarrow 6	0.40	Gentiobiose	1 \rightarrow 6	0.58

in rate is slight. With those disaccharides in which the aglycon glucose unit is linked through a secondary alcoholic group (*i.e.*, at positions 2, 3, and 4) the α anomers react more rapidly. This is the reverse of that found with methyl glucosides and is presumably a steric effect, there being a slight acceleration when the bulky aglycon is attached at the axial position. Consistent with this, when the aglycon is attached through the primary 6 position, the β anomer reacts slightly faster. Also the comparison of the rates of hydrolysis of disaccharides with those of the corresponding methyl glucosides given in Tables

(153) J. S. Sequeira, Ph.D. Thesis, University of London, 1960.

(154) H. S. Isbell and H. L. Frush, *J. Res. Nat. Bur. Stand.*, **24**, 131 (1940).

(155) C. N. Rjiber and N. A. Sørensen, *Kgl. Norske Videnskab. Selskabs Skrifter*, No. 1, 1 (1938).

(156) (a) J. P. Horwitz, C. V. Easwaran, and L. S. Kowalczyk, *J. Org. Chem.*, **33**, 3174 (1968); E. R. B. Graham and A. Neuberger, *J. Chem. Soc. C*, 1638 (1968); (b) M. L. Wolfrom, A. Thompson, and C. E. Timberlake, *Cereal Chem.*, **40**, 82 (1963).

(151) N. B. Chapman and W. E. Laird, *Chem. Ind.* (London), 20 (1954).

(152) J. T. Edward, *ibid.*, 1102 (1955).

XX and XXIV shows that maltose undergoes hydrolysis nine times faster than methyl α -D-glucoside but that the rate for cellobiose is only slightly larger than that for methyl β -D-glucoside.

Table XXIV

First-Order Rate Constants and Activation Parameters for the Hydrolysis of Some Disaccharides in 0.5 M Sulfuric Acid¹¹⁹

	10^3k at 70°, sec ⁻¹	E_{a1} , kcal mole ⁻¹	ΔS^\ddagger , eu
4-O- α -D-Glucopyranosyl-D-glucose (maltose)	23.6	32.7	+14.0
4-O- β -D-Glucopyranosyl-D-glucose (cellobiose)	9.63	31.5	+9.0
6-O- β -D-Glucopyranosyl-D-glucose (gentiobiose)	5.22	32.9	+11.7
4-O- β -D-Glucopyranosyl-D-mannose (glucosyl-mannose)	9.40	32.0	+10.2
4-O- β -D-Mannopyranosyl-D-mannose (mannobiose)	16.8	32.7	+13.4
4-O- β -D-Galactopyranosyl-D-glucose (lactose)	22.5	33.0	+14.9
6-O- β -D-Galactopyranosyl-D-glucose (melibiose)	21.2	33.8	+17.1
4-O- β -D-Xylopyranosyl-D-xylose (xylobiose)	69.8	32.7	+16.5
Methyl α -D-glucopyranoside	2.85	35.1	+16.9
Methyl β -D-glucopyranoside	6.25	32.5	+10.6

The only 1→1 linked diglucose whose hydrolysis has been investigated kinetically is α,α -trehalose which reacts appreciably slower than any of its 1→2, 1→3, 1→4, and 1→6 linked isomers (*cf.* Tables XX and XXIII). The reason for this is not clear. Electron-withdrawing substituents in the aglycon of alkyl glycosides are normally slightly rate enhancing (see Table VIII). On the grounds then that the aglycon glucose residue of α,α -trehalose is attached through C(1) which bears another oxygen, it might be expected that it would react faster, not slower, than the other D-glucosyl α -D-glucosides. An explanation in terms of steric effects was offered by Edward¹⁵² who suggested that the glucoside oxygen is sheltered by the axial hydrogen atoms of the two pyranose rings and that a conformational inversion may occur before hydrolysis (eq 4). It is difficult to judge the soundness of this suggestion in the absence of kinetic data on the hydrolysis of α,β - and β,β -trehalose. It should be noted, however, that more recent

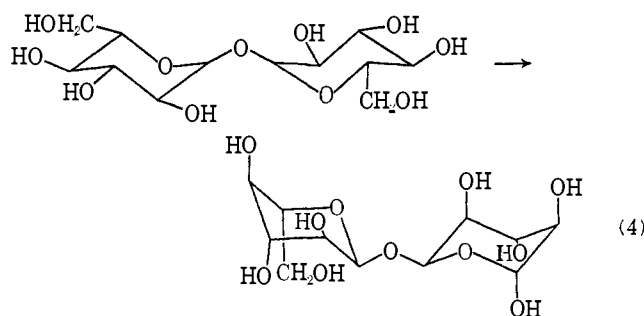

work¹⁵³ indicates that the hydrolysis of α,α -trehalose is not quite so slow as was originally thought¹⁵⁷ (see Table XX).

(157) A. Moelwyn-Hughes, *Trans. Faraday Soc.*, 25, 513 (1929).

Other kinetic investigations of the hydrolysis of di- and trisaccharides include those given in ref 138, 140, 150, 158–162a–d.

4. Sulfur- and Selenium-Containing Glycosides

Replacing the ring oxygen of methyl α - and β -D-xylopyranoside by sulfur results in a 10- to 15-fold increase in the rate of the acid-catalyzed hydrolysis.¹⁶³ It is reasonable to suppose that in acidic solutions the concentration of the conjugate acid of the 5-thioxylopyranosides (*e.g.*, 53) would be higher than with the xylopyranosides because of the poorer electron-withdrawing inductive effect of the sulfur as compared with oxygen. The decomposition of the conjugate acid would be expected to be faster with the latter, however, since carbonium ion 54 should be less stable than its oxygen analog. These two

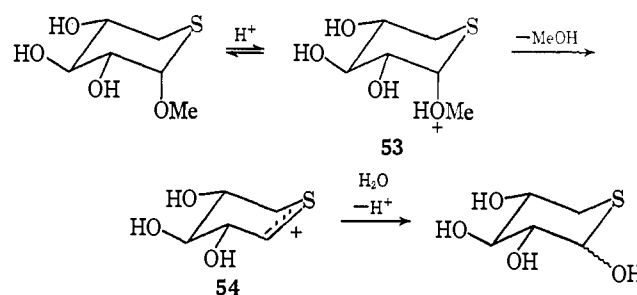

different effects act in opposition, and clearly the former is the most important. The hydrolyses of the methyl 5-thioribopyranosides are similarly about ten times faster than those of the corresponding methyl ribopyranosides.¹⁶⁴

Replacing the glycosidic oxygen of glycosides by sulfur usually has a rate-decreasing effect. This is small with alkyl glycosides but quite large for phenyl β -D-glucoside (see Table XXVI).¹⁶⁵ It is difficult to decide if the mechanism of hydrolysis of these thioglycosides is the same as that of the oxygen glycosides, although the similar highly positive entropies of activation,¹⁶⁵ the similar ρ value for the hydrolysis of aryl β -D-thioglycosides ($\rho = -0.9$), and the similar effect of altering the configuration of the sugar (see Table XXV)^{166a} are

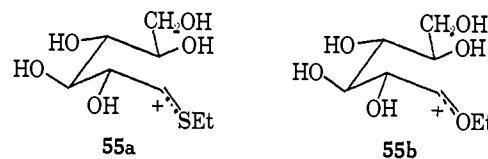

consistent with this being so. Sulfur is less basic than oxygen so the concentration of S-protonated conjugate acid must be lower, and hence a decrease in the rate of hydrolysis *via* the cyclic ion would be expected on this count. A decrease in the

(158) A. Meller, *J. Polymer Sci.*, C, No. 2, 97 (1963); *A-1*, 5, 1443 (1967).

(159) K. Freudenberg, W. Durr, and H. von Hochstetter, *Ber.*, 61, 1738 (1928).

(160) E. A. Moelwyn-Hughes, *Trans. Faraday Soc.*, 25, 503 (1929).

(161) G. Noto La Diega, *Ann. Chim. (Rome)*, 56, 367 (1966).

(162) (a) Y. Hirasaka and I. Matsunga, *Chem. Pharm. Bull. (Tokyo)*, 13, 176 (1965); (b) M. S. Feather and J. F. Harris, *J. Amer. Chem. Soc.*, 89, 5661 (1967); (c) N. Roy and T. E. Timell, *Carbohydr. Res.*, 6, 475, 482, 488 (1968); 7, 17 (1968); (d) J. Rosik and J. Kubala, *Collect. Czech. Chem. Commun.*, 33, 1946 (1968).

(163) R. L. Whistler and T. Van Es, *J. Org. Chem.*, 28, 2303 (1963).

(164) C. J. Clayton and N. A. Hughes, *Carbohydr. Res.*, 4, 32 (1967).

(165) C. Bamford, B. Capon, and W. G. Overend, *J. Chem. Soc.*, 5138 (1962).

(166) (a) G. Wagner and M. Wogler, *Arch. Pharm.*, 297, 348 (1964); (b) M. D. Saunders and T. E. Timell, *Carbohydr. Res.*, 6, 121 (1968).

Table XXV
First-Order Rate Constants for the Hydrolysis of Aryl Thioglycosides in 3 M Hydrochloric Acid at 80°^{168a}

Thioglycoside	$10^4 k, \text{sec}^{-1}$
4-Nitrophenyl β -D-thioglucoside	2.15
4-Bromophenyl β -D-thioglucoside	3.56
4-Chlorophenyl β -D-thioglucoside	3.67
Phenyl β -D-thioglucoside	11.1
4-Methylphenyl β -D-thioglucoside	8.75
4-Methoxyphenyl β -D-thioglucoside	15.9
4-Hydroxy β -D-thioglucoside	26.0
4-Methylphenyl β -D-thiogalactoside	44.4
4-Methylphenyl β -D-thioxyloside	63.6
4-Methylphenyl α -L-thioarabinoside	86.7

Table XXVI
First-Order Rate Constants and Activation Parameters for the Hydrolysis of Some Sulfur-Containing Glycosides in Hydrochloric Acid (2 M)¹⁶⁵

Glycoside	$10^4 k, \text{at } 70^\circ, \text{sec}^{-1}$	E_a	ΔS^\ddagger
Ethyl β -D-glucopyranoside	7.07
Ethyl 1-thio- β -D-glucopyranoside	2.13	32.8	12.4
Phenyl β -D-glucopyranoside	31.6	31.0	12.6
Phenyl 1-thio- β -D-glucopyranoside	0.088	33.7	10.8

rate of hydrolysis proceeding *via* the acyclic ion would also be expected since the α -thiocarbonium ion (*e.g.*, **55a**) would be less stable than the α -oxygen ion (*e.g.*, **55b**).

From the limited results given in Table XXVIa, it appears that the rates of hydrolyses of alkyl 1-thio- β -D-glucopyranosiduronic acids (**56a**) are less sensitive to the effect of substituents in the aglycon than those of alkyl 1-thio- β -D-glucopyranosides (**56b**).^{168b} This trend is similar to that found with

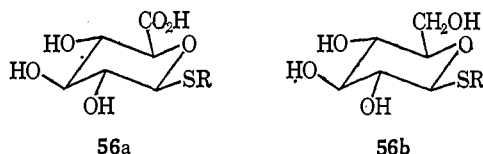

their oxygen analogs (see section II.A.2), and again interpretation is complicated by the fact that the forms of the 1-thio- β -D-glucopyranosiduronic acids with the carboxyl group ionized and un-ionized are probably undergoing hydrolysis simultaneously. Nevertheless, the results suggest that the effect of substituents on the equilibrium constant for protonation of the sulfur of the thioglucopyranosiduronic acids is more important relative to their effect on the rate constant for heterolysis of the conjugate acid than with the thioglucopyranosides.

The substituent effects with the thioglucopyranosiduronic acids are also less than with the corresponding glucopyranosiduronic acids (compare Tables VIII and XXVIa), and this results in a reversal of reactivity, with 2-hydroxyethyl thio- β -D-glucopyranosiduronic acid undergoing hydrolysis about twice as rapidly as 2-hydroxyethyl- β -D-glucopyranosiduronic acid.^{168b}

In a very interesting investigation by Clayton, Hughes, and Saeed,¹⁶⁷ it has been shown that the hydrolysis of methyl 1-thio- α -D-ribofuranoside is accompanied by anomerization and ring contraction. A reaction solution in 0.4 M hydrochloric acid, after refluxing for 6 min, contained in addition to α -pyranoside (**57**, 18.5%), β -pyranoside (**58**, 7.4%), α -furanoside (**59**, 5.8%), and β -furanoside (**60**, 15.4%). Clearly the anomerization and ring contraction must involve ring opening, but whether hydrolysis does as well is not known. An acyclic ion (**61**) was thought to be an intermediate in the anomerization and ring contraction, and it is of interest that an ion of similar structure, **62**, was thought to be an intermediate in another reaction (eq 5) and that this yielded a mixture of furanosides, not fructose.¹⁶⁸ It is possible, however, that ion **61** is formed reversibly and is only occasionally captured by water to yield ribose. At present then, it cannot be said if hydrolysis proceeds *via* ion **61** or *via* a cyclic ion.

It is not known if the thioglucopyranosides undergo a similar anomerization and ring contraction concurrent with their hydrolysis but the latter should occur much less readily than with the thioribopyranoside. Ring expansion and anomerization does occur, however, with ethyl 1-thio- α -D-glucopyranoside which yields β -thiofuranoside and α -thiopyranoside on heating with 0.01 M hydrochloric acid at 100°.¹⁶⁹

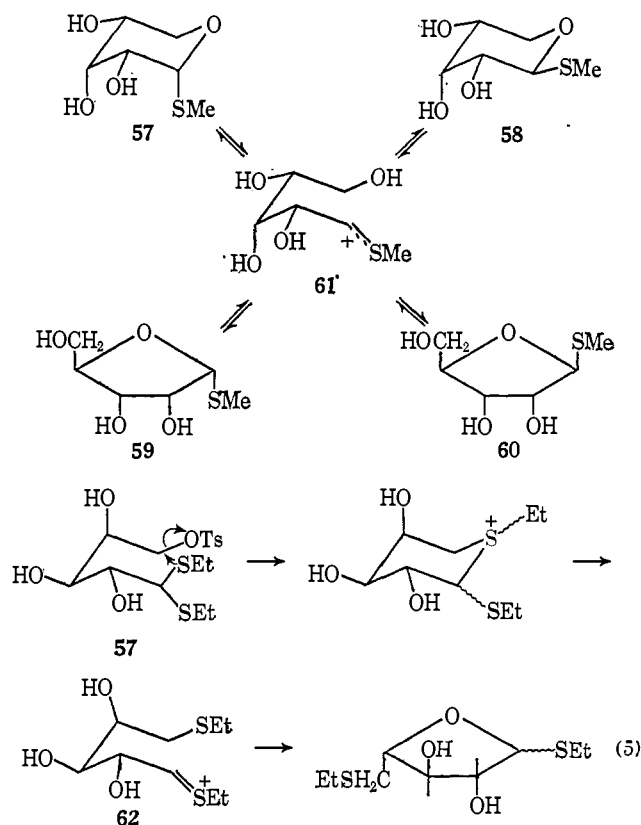

The hydrolysis of methyl 1-thio- β -D-xylothiopyranoside, in which both the ring and glycosidic oxygen have been replaced by sulfur, has also been investigated. The rate at 75° is about 30% less than the rate of hydrolysis of methyl β -D-xylothiopyranoside.¹⁷⁰

(167) C. J. Clayton, N. A. Hughes, and S. A. Saeed, *J. Chem. Soc., C*, 644 (1967).

(168) N. A. Hughes and R. Robson, *ibid.*, 2366 (1966).

(169) E. Pacsu and E. J. Wilson, *J. Amer. Chem. Soc.*, 61, 1450 (1939).

(170) R. L. Whistler and R. M. Rowell, *J. Org. Chem.*, 29, 3290 (1964).

Table XXVIa

First-Order Rate Constants and Activation Parameters for the Acid-Catalyzed Hydrolyses of Some Alkyl 1-Thio- β -D-Glycopyranosides and 1-Thio- β -D-Glycopyranosiduronic Acids in 0.5 M Sulfuric Acid at 70° 186b

Alkyl	—1-Thio- β -D-glycopyranosides (56b)—			1-Thio- β -D-glycopyranosiduronic acids (56a)		
	$10^6 k_1, \text{sec}^{-1}$	$E_a, \text{kcal/mole}^{-1}$	$\Delta S^\ddagger, \text{cal deg}^{-1} \text{mole}^{-1}$	$10^6 k_1, \text{sec}^{-1}$	$E_a, \text{kcal mole}^{-1}$	$\Delta S^\ddagger, \text{cal deg}^{-1} \text{mole}^{-1}$
Isopropyl	4.77	35.5	+19.0	19.4	30.3	+6.6
Propyl	3.66	33.1	+11.5	16.4	30.7	+7.3
2-Hydroxymethyl	0.668	34.8	+13.0	5.37	30.9	+5.8

^a See p 420.

The hydrolysis of phenyl 1-seleno- β -D-glucoside is slightly slower in 3 M hydrochloric acid at 90° than that of its sulfur analog, whereas that of *p*-nitrophenyl 1-seleno- β -D-glucoside is slightly faster than that of its sulfur analog.¹⁷¹

B. INTRAMOLECULAR CATALYSIS

In most theories of the mechanism of glycosidase action, it is postulated that after formation of an enzyme-glycoside complex the glycoside undergoes hydrolysis with an acidic group of the enzyme providing general acid catalysis.¹⁷²⁻¹⁷⁶ If this is correct, it would be expected that a glycoside in which an acidic group is "built in" close to the glycosidic link would undergo hydrolysis with intramolecular catalysis. This prediction was borne out by an investigation of the hydrolysis of 2-carboxyphenyl β -D-glucoside (63).^{177, 178} In the pH range 1.0-5.5, the rate law is of the form $k_{\text{obsd}} = k_1[\text{un-ionized form}] + k_2[\text{un-ionized form}]a_{\text{H}^+}$ with $k_1 = 1.41 \times 10^{-3} \text{ sec}^{-1}$ and $k_2 = 5.49 \times 10^{-3} \text{ l. mole}^{-1} \text{ sec}^{-1}$ at 91.35°. The second term on the right-hand side of this equation corresponds to a specific hydrogen-ion catalyzed hydrolysis of the un-ionized form of the glucoside and the value of k_2 is of the order of magnitude to be expected from the inductive effect of the carboxyl group. The first term corresponds either to a spontaneous hydrolysis of the un-ionized glucoside or to a specific hydrogen-ion catalyzed hydrolysis of the ionized form, and the value of k_1 causes the observed rate constant to be 284 times greater than that for 4-carboxyphenyl β -D-glucoside at pH 2 and 1.3×10^4 times greater than the extrapolated value for this glucoside at pH 4.55.

Two mechanisms were considered to explain these observations. In the first (eq 6) the un-ionized carboxyl group was written as providing intramolecular general acid catalysis; i.e., transferring a proton synchronously with rupture of the glycosidic bond. In the second (eq 7) the ionized carboxyl group provides intramolecular nucleophilic catalysis in association with specific hydrogen-ion catalysis. It was shown that

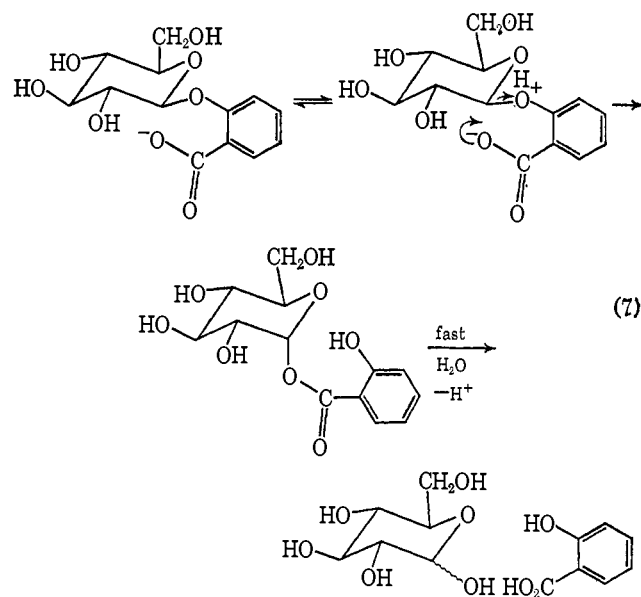
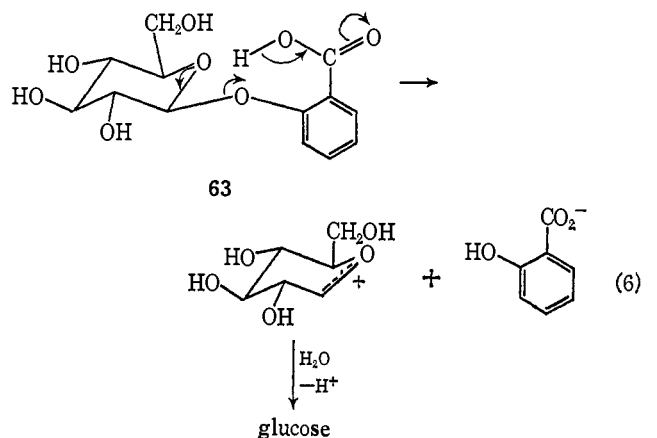

the hydrolysis of an acetal of analogous structure, 2-methoxy-methoxybenzoic acid, probably proceeded with intramolecular general acid catalysis by a mechanism similar to that of eq 6, and since the hydrolyses of the acetal and glucoside were kinetically similar this mechanism was considered most likely for the glucoside also.^{179a} It is consistent with the solvent deuterium isotope effect $k_1(\text{H}_2\text{O})/k_1(\text{D}_2\text{O}) = 1.3$ and with glucoside 64a with a nitro substituent giving a higher value of k_1 ; $k_1(4\text{-NO}_2)/k_1(\text{H}) = 3.37$. This contrasts with the rate

(171) G. Wagner and P. Nuhn, *Arch. Pharm. (Weinheim)*, 298, 692 (1965).

(172) E. H. Filscher and E. A. Stein, *Enzymes*, 4, 340 (1960).

(173) K. Wallenfels and P. Malhotra, *ibid.*, 4, 427 (1960).

(174) K. Wallenfels and P. Malhotra, *Advan. Carbohydr. Chem.*, 16, 285 (1961).

(175) W. W. Pigman, "The Carbohydrates," Academic Press, New York, N. Y., 1957, p 566.

(176) D. French, *Baker's Dig.*, 32, 50 (1957).

(177) B. Capon, *Tetrahedron Lett.*, 911 (1963).

(178) E. Anderson, B. Capon, R. H. Dahm, G. H. Sankey, and M. C. Smith, *J. Chem. Soc., B*, in press.

(179) (a) B. Capon and M. C. Smith, *Chem. Commun.*, 523 (1965); (b) B. Capon and R. L. Foster, unpublished observations; D. Piszkiwicz and T. C. Bruice, *J. Amer. Chem. Soc.*, 90, 2156 (1968).

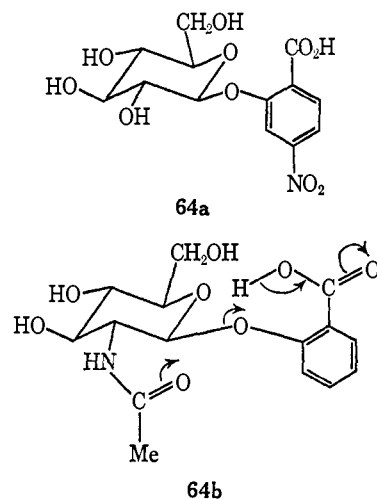

decelerating effect of a *m*-nitro substituent in the specific acid catalyzed hydrolysis of β -glucosides (see Table VII) and presumably arises from the acid-strengthening effect on the carboxyl group making it a more effective catalyst.

The hydrolysis of 2-carboxyphenyl 2-acetamido-2-deoxy- β -D-glucoside has a similar pH-rate profile to that of the glucoside. At pH 4 the rate constant for the hydrolysis of the 2-acetamido-2-deoxyglucoside is about 20 times greater than that of the glucoside, and its methanolysis proceeds with retention of configuration.^{179b} These observations suggest that the hydrolysis of the 2-acetamidoglucoside involves bifunctional catalysis and that in addition to intramolecular general acid catalysis there is also intramolecular nucleophilic catalysis as depicted in **64b**.

It seems likely that the hydrolyses of certain poly- and oligosaccharides containing uronic acid residues which proceed at enhanced rates also involve intramolecular acid catalysis.¹⁴³ Thus 3-*O*- β -D-glucopyranosyl-L-gulonic acid (**65a**) is hydrolyzed more than 100 times faster than 4-*O*- β -D-glucopyranosyl-D-glucitol (**65b**) at pH 4. Although a complete pH-rate profile for the hydrolysis of **65a** was not determined, the results obtained suggest that a term, $\text{rate} = k[\text{glycoside with un-ionized carboxyl group}]$, makes an important contribution to the over-all rate. A mechanism involving intramolecular catalysis (*cf.* **65c**) was proposed for this reaction and for the hydrolysis of alginic acid, a polysaccharide containing uronic acid residues, which is hydrolyzed at an enhanced rate and shows a similar dependence of rate on pH.¹⁸⁰

Intramolecular catalysis has also been postulated to occur in the hydrolysis of methoxysialic acid,¹⁸¹ but the enhanced rate of hydrolysis of this compound in which the carboxyl

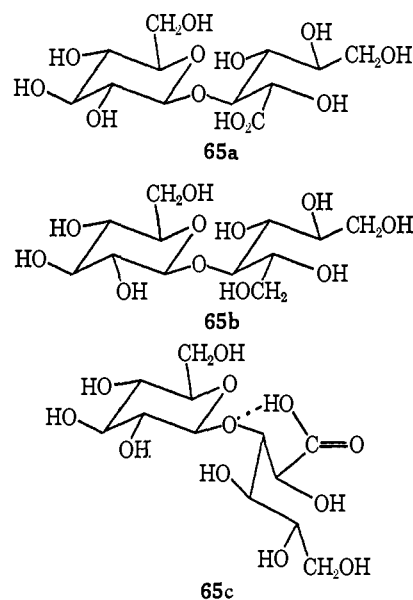

group is in the glycon moiety probably results from a specific hydrogen-ion catalyzed hydrolysis of the form with the carboxyl group ionized.¹⁸²

The rate of the acid-catalyzed hydrolysis of 2-pyridyl glucosides is high,^{183a} and it has been suggested that this is the result of intramolecular catalysis as symbolized by **6**.^{183b} This involves a four-membered hydrogen-bonded ring,⁶ but a stereochemical more reasonable transition state would involve a water molecule and a six-membered ring. However, in the reviewer's opinion it is more likely that the reaction does not involve intramolecular catalysis at all but that the driving force is derived from N-protonated 2-hydroxypyridine being a very good leaving group since it separates as the stable 2-pyridone. It is significant that the standard free-energy change for the conversion of 2-methoxypyridine into 1-methyl-2-pyridone in the gas phase has recently been evaluated as < -6 kcal mole⁻¹, while that for the conversion of 4-methoxypyridine into 1-methyl-4-pyridone was given as only < -2 kcal mole⁻¹.¹⁸⁴

2-Pyridazinyl glucosides are hydrolyzed more rapidly than 2-pyridyl glucosides and 5-cyano- and 5-chloro-2-(1- β -D-glucopyranosyloxy)pyridazine react so fast that the anomeric configuration of the glucose first formed can be determined and is α , the reaction proceeding with predominant inversion.^{183b}

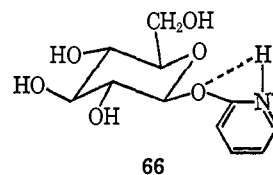

(180) Some confusion concerning this work has arisen through the discussion of T. C. Bruice and D. Piszkiwicz (*J. Amer. Chem. Soc.*, **89**, 3568 (1967)). In a general review of intramolecular catalysis of acetal and glycoside hydrolysis these authors discussed the results of Smidsrød, Haug, and Larsen¹⁴³ on the hydrolysis of alginic acid but ignored the results obtained for compound **65a**. They concluded that the enhanced rate of hydrolysis of alginic acid is not the result of intramolecular catalysis on the grounds that the enhanced rate of hydrolysis of 2-naphthyl glucuronide is solely the result of an inductive effect (*cf.* p 420). The latter result is irrelevant, however, because in this compound the carboxyl group is in the glycon portion of the glycoside whereas the process postulated by Smidsrød, Haug, and Larsen for the hydrolysis of alginic acid, as well as for that of **65a**, involved intramolecular catalysis by a carboxyl group in an aglycon position (*cf.* **65c**). In the reviewer's opinion, this mechanism requires further supporting evidence before it can be unequivocally accepted, but that the arguments used by Bruice and Piszkiwicz to dismiss it are fallacious as they are based on a misunderstanding of process being postulated.

(181) J. D. Karkas and E. Chargaff, *J. Biol. Chem.*, **239**, 949 (1964).

(182) A. Neuberger and R. D. Marshall in "Glycoproteins," A. Gottshalk, Ed., Elsevier, Amsterdam, 1966, p 192.

(183) (a) Recent work indicates that 2-pyridyl β -D-glucoside is hydrolyzed only about eight times faster than 4-pyridyl β -D-glucoside. This factor is much less than that originally reported (see ref 183b where half-lives of 11 min and ∞ , respectively, were claimed). Similar differences in rates are found between 2- and 4-pyridyl thio- and seleno- β -D-glucosides: G. Wagner and G. Valz, *Pharmazie*, **22**, 548 (1967). (b) G. Wagner and H. Frenzel, *Z. Chem.*, **5**, 454 (1965); *Arch. Pharm.*, **300**, 591 (1967); see also, G. Wagner and F. Süß, *ibid.*, **300**, 1027 (1967).

(184) P. Beak and J. Boham, *Chem. Commun.*, 631 (1966); P. Beak, J. Bonham, and J. T. Lee, *J. Amer. Chem. Soc.*, **90**, 1569 (1968).

III. Acid-Catalyzed Hydrolysis of Glycofuranosides

A. ALDOFURANOSIDES

1. Mechanism

There have been a lot fewer kinetic and mechanistic investigations of the hydrolysis of aldofuranosides than of aldopyranosides. The only aldofuranoside for which the position of bond fission has been determined is ethyl β -D-galactofuranoside which was shown to react, as expected, with galactosyl-oxygen

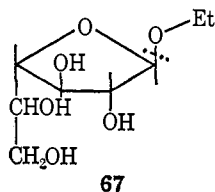

fission (see 67),¹⁸⁵ and it is reasonable to suppose that other ethyl and methyl aldofuranosides react similarly. The solvent deuterium isotope effect for the hydrolysis of methyl α -D-xylofuranoside in 1 M hydrochloric acid at 25° is $k_{D_2O}/k_{H_2O} = 2.5$, consistent with a rapid and reversible initial proton transfer to form a conjugate acid of the furanose which could be either 68 or 69.

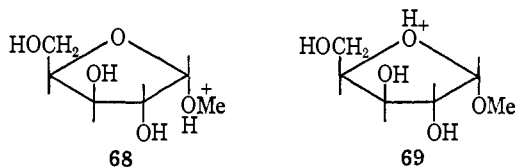

In striking contrast to the strongly positive entropies of activation found for the hydrolysis of aldopyranosides, the hydrolysis of all the aldofuranosides so far studied have negative entropies of activation (see Table XXVII). This suggests that the mechanism of hydrolysis for these two classes of glycosides are different, and the simplest explanation would be that whereas that for pyranosides is A1 (see section II), that for furanosides is A2 (see eq 8). This is supported by the Bunnett w values for the galacto- and xylofuranosides which have values (+1.0 to +2.4) falling in the range considered to indicate a mechanism in which water acts as a nucleophile.

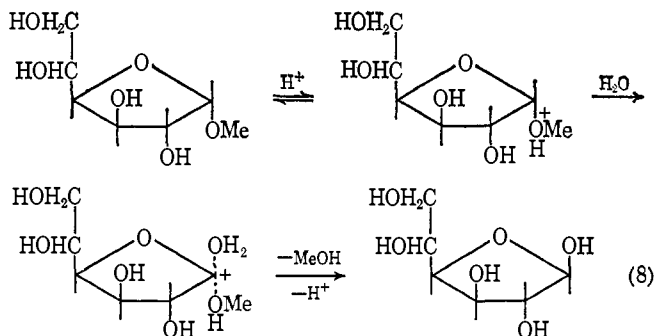

This change in mechanism can be rationalized if it is assumed that attainment of the conformation necessary for maximum overlap between the developing p orbital on C(1) and the p orbital of the stabilizing oxygen atom is much more

Table XXVII

The Kinetics of the Hydrolysis of Aldofuranosides

Methyl furanoside	Temp., °C	$10^3 k_1$, sec ⁻¹	E_a , kcal mole ⁻¹ ± 1	ΔS^\ddagger , eu ± 2
1 M Perchloric Acid ¹⁸⁵				
α -D-Xylo-	25.03	39.5	20.2	-8.3
	35.04	120		
β -D-Xylo-	25.01	26.3	20.3	-8.9
	35.04	79.4		
β -L-Arabino-	24.92	4.46	23.1	-2.8
	35.12	16.2		
α -D-Galacto-	25.03	3.35	21.4	-9.4
	35.91	10.8		
β -D-Galacto-	25.02	0.405	22.8	-8.7
	35.12	1.43		
	35.12	175		
α -D-Gluco-	24.92	59.7	19.2	-11.0
	35.12	175		
β -D-Gluco-	25.00	21.0	20.5	-9.0
	34.00	64.3		
0.5 M Sulfuric Acid ^{186b}				
α -D-Glucofuranosidurono-3,6-lactone	35.0	9.35	19.3	-16.5
	40.0	16.0		
	45.0	25.9		
	50.0	41.9		
β -D-Glucofuranosidurono-3,6-lactone	35.0	3.53	16.2	-28.5
	40.0	5.69		
	45.0	8.45		
	50.0	12.7		
2 M Hydrochloric Acid ¹¹⁷				
<i>Ethyl furanoside</i>				
β -D-Galacto-	19.8	2.56	22.7	-7.1
	29.1	8.72		
	39.7	31.1		

difficult when the latter is part of a ring, thus causing a diminution in the rate of the A1 hydrolysis. With pyranosides the incursion of an A2 mechanism is also probably not favored since nucleophilic attack on six-membered rings is normally a slow process (*cf.* ref 186a). Nucleophilic attack on five-membered rings occurs much more rapidly though, and hence the incursion of an A2 mechanism does not seem unreasonable.

It does seem, however, that a mechanism involving ring opening would also have a negative entropy of activation if it involved either the reversible formation of a carbonium ion (eq 9) or a concerted process (eq 10). The following arguments show that it is reasonable for pyranosides to be undergoing hydrolysis through a cyclic carbonium ion and furanosides with ring opening. Five-membered rings are normally formed from saturated acyclic compounds more rapidly than the corresponding six-membered ones (see ref 187). In particular, the cyclization of acyclic glucose, galactose, and arabinose acetals yields furanosides at least 200 times more rapidly than pyranosides, although the latter are thermodynamically more stable.^{188, 189} The free-energy diagram is therefore as shown

(186) (a) E. L. Eliel, "Stereochemistry of Carbon Compounds," McGraw-Hill Book Co., Inc., New York, N. Y., 1962, p 265; (b) E. Tomita and Y. Nitta, *Yakugaku Zasshi*, **87**, 495 (1967).

(187) B. Capon, *Quart. Rev. (London)*, **18**, 105 (1964).

(188) B. Capon and D. Thacker, *J. Amer. Chem. Soc.*, **87**, 4199 (1965).

(189) B. Capon and D. Thacker, *J. Chem. Soc.*, **B**, 1322 (1967).

(185) B. Capon and D. Thacker, *J. Chem. Soc.*, **B**, 185 (1967).

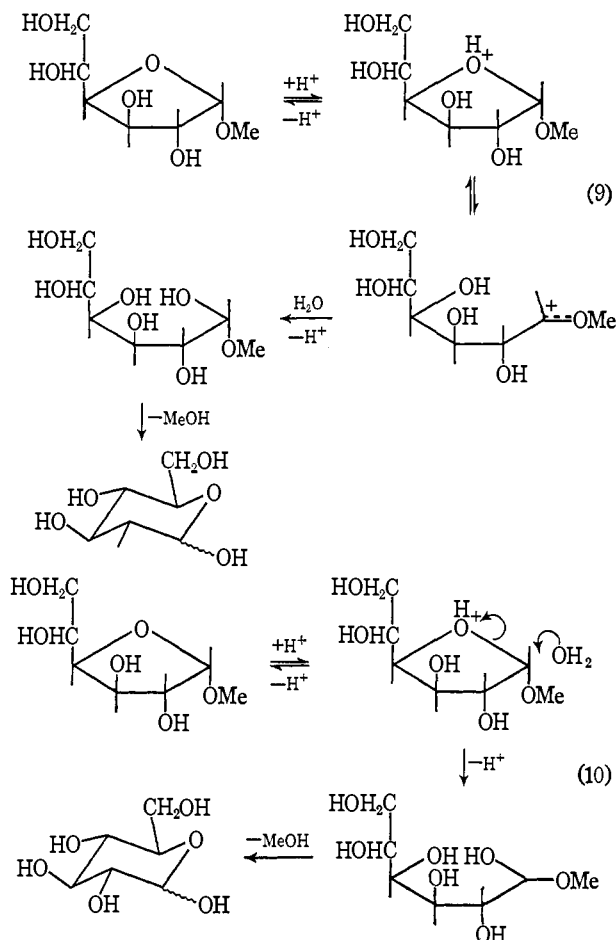

in Figure 2. The ring openings of pyranosides and furanosides by water are not the exact microscopic reverse of these ring closures, so the principle of microscopic reversibility cannot be strictly applied. Nevertheless, the difference is not large, and since the free-energy diagram shows that the energy of activation for the ring opening of furanosides by methanol should be at least 3.6 kcal mole⁻¹ less than for ring opening of pyranosides, it would be reasonable to expect a similar difference for ring opening by water.

Anomerization of aldofuranosides concurrent with their hydrolysis has never been detected so that if the mechanism of eq 9 is being followed, recyclization of the carbonium must occur much more rapidly than rotation about the C(1)-C(2) bond.

Support for a concerted ring opening (eq 10) comes from the fact that the ring closure of the acyclic acetals to yield furanosides and methanol is concerted. The ring opening of furanosides by methanol must therefore also be concerted, and hence it is likely that the analogous ring opening by water is as well. There are then at least three possible mechanisms for the hydrolysis of aldofuranosides, and at present it is not possible to distinguish between them.

Another possible mechanism to account for the negative values of ΔS^\ddagger , which was also considered was that the reaction involved nucleophilic participation by a hydroxyl group as shown in 70 or 71, similar to that demonstrated to occur in the ring closure of aldose acetals (see section VII). This possibility was excluded, however, by the results for methyl α -D-galactofuranoside (72) with which such participation would not be possible. The entropy of activation is similar to

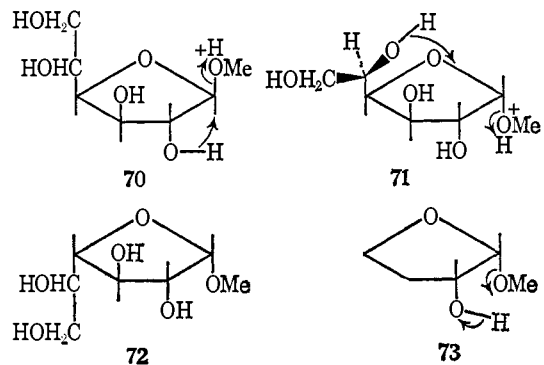

that for the other furanosides, and the rate of hydrolysis is larger than that for methyl β -D-galactofuranoside with which nucleophilic participation of this kind could occur.

The possibility of intramolecular acid catalysis by a vicinal hydroxyl group as symbolized by 73 was also considered. This would be expected to be more important when the hydroxyl group is *cis* than when it is *trans*, and the rate of any hydrolysis proceeding by this mechanism would be independent of the concentration of hydrogen ions. The results given in Table XXVIII show that this is not so, and therefore, in the pH range studied, a process such as 73 is not important. The hydroxyl groups thus appear to provide neither nucleophilic nor electrophilic assistance in these reactions.

Table XXVIII

	$10^3 k, \text{sec}^{-1}$	$10^3 k, \text{sec}^{-1}$
	$1 M HClO_4$	Acetate buffer
	at 25°	(pH 3.8)
	at 80°	
Methyl α -D-xylofuranoside	39.5	11.0
Methyl β -D-xylofuranoside	26.3	9.3
$k(\text{cis})/k(\text{trans})$	1.5	1.2

2. Structure and Reactivity

The relative reactivities of aldofuranosides have been determined by a number of workers,^{185, 190-192} and some of their results are given in Tables XXVII and XXIX. The most striking feature is the high rates with the glucosides 74 and xylosides 75 compared to the galactosides 76 and arabinosides

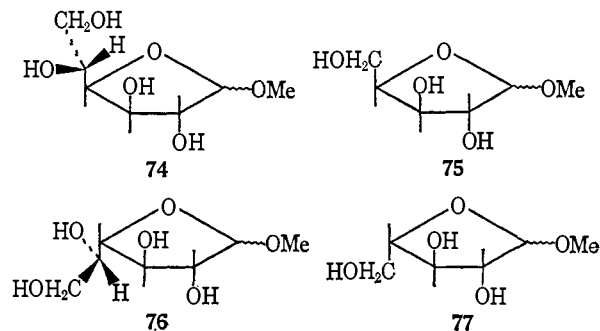

(190) W. N. Haworth, *Ber.*, 65A, 43 (1932).

(191) I. Augestad and E. Berner, *Acta Chem. Scand.*, 10, 911 (1956).

(192) O. Kjoelberg and O. J. Tjelveit, *ibid.*, 17, 1641 (1963).

Table XXIX

First-Order Rate Constants for the Hydrolysis of Some Methyl Aldofuranosides in 1 M HCl at 20°¹⁹⁰⁻¹⁹²

Furanoside of	$10^6 k_{\alpha_1}$ sec^{-1}	cis or trans ^a	$10^6 k_{\beta_1}$ sec^{-1}	cis or trans ^a
L-Arabinose	3.43	trans	23.3	cis
D-Ribose	...		112	trans
D-Xylose	213	cis	125	trans
D-Lyxose	26.1	trans	105	cis
D-Galactose	17.3	cis	2.05	trans
D-Mannose	5.45	trans	78.5	cis
L-Fucose	8.17	cis	2.5	trans
L-Rhamnose	8.33	trans	...	

^a Relationship between methoxyl at position 1 and hydroxyl at position 2.

77. This is presumably largely due to the low initial-state free energies of the latter compounds which have the substituents on C(2), C(3), and C(4), *trans* to one another. A complete understanding of these reactivities is not possible at present, however, since not only is the mechanism uncertain (see previous section), but also we do not know the conformations of these furanosides or even if they each exist in only one conformation (see section I). Whatever the conformation though, there will be a large amount of eclipsing strain which will be larger when substituents on adjacent carbons are *cis* than when they are *trans*. If the mechanism involves ring opening, there will be movement toward a more staggered conformation in the transition state and hence relief of eclipsing strain which should be greatest for those furanosides in which this is largest in the initial state. It is not easy to see what the conformational movements would be if the reaction involved a bimolecular displacement of methanol, especially as the initial conformations are unknown, but clearly the relief or increase in strain on passing to the transition state will depend on the configuration of the starting furanoside. This cannot be the only important factor though since reactivities do not parallel exactly the number of *cis* substituents, lyxosides 78 being less reactive than xylosides 75, for example.

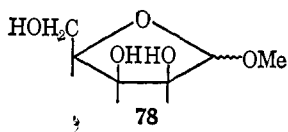

It is doubtful also if the greater reactivities of the *cis*-1,2-furanosides compared to their anomers can result wholly from a difference in initial-state free energies since the latter (measured in methanol) are often less than the difference in the free energies of activation (measured in water). For example, the values of ΔG° for the gluco-, xylo-, and arabinofuranosides are respectively 310, 310, and -700 cal mole⁻¹, whereas the differences in the free energies of activation for the hydrolyses of the same furanosides at the same temperature (20-25°) are 385, 200, and -1130 cal mole⁻¹.

B. KETOFURANOSIDES

There have been many kinetic investigations of the hydrolysis of the ketofuranoside sucrose (e.g., ref 193-196) since that

- (193) V. K. Kriehle, *J. Amer. Chem. Soc.*, **57**, 15 (1935).
 (194) V. K. Kriehle and K. A. Holst, *ibid.*, **60**, 2976 (1938).
 (195) P. M. Leininger and M. Kilpatrick, *ibid.*, **60**, 2891 (1938).
 (196) E. A. Moelwyn-Hughes, *Z. Physik. Chem.*, **B26**, 281 (1934).

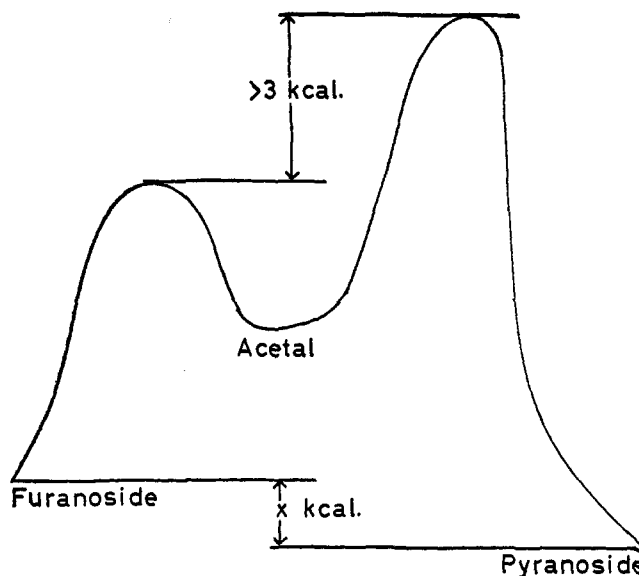
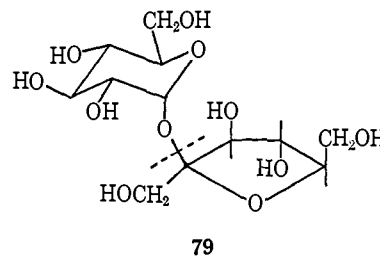

Figure 2. Free-energy diagram for the formation of methyl glycosides from aldose dimethyl acetals (not to scale); $x = 2-3$ kcal mole⁻¹ with glucose and xylose and 0.6 kcal mole⁻¹ with arabinose.

of Wihelmy in 1850,¹⁹⁷ but surprisingly few of these are of mechanistic significance. The reaction has a positive entropy (+7.9 eu)^{198,199} and volume (+6 cm³ mole⁻¹)²⁰⁰ of activation, and the rate may be correlated with H_0 ,²⁰¹ so the mechanism is presumably A1. The position of bond fission has apparently never been determined, but fructosyl-oxygen fission (79) seems most likely since this would lead to a tertiary carbonium



ion whereas glucosyl-oxygen fission would lead to a secondary one. This view is supported by the 10⁵-fold greater rate of hydrolysis of methyl α -D-fructofuranoside than of methyl α -D-glucopyranoside.^{202,203} The hydrolysis of the former also has a positive entropy of activation (+12.6 eu; calculated from the results of ref 202, 203) and so the mechanism is probably A1. This change in mechanism on going from aldo- to ketofuranosides would reasonably result from the change in the intermediate ion from being secondary to being tertiary.

IV. Alkaline Fission of Glycosides^{204,205}

Alkyl glycosides react with hydroxide ions under strongly forcing conditions only, but aryl glycosides react more readily,

- (197) L. Wihelmy, *Pogg. Ann.*, **81**, 413, 499 (1850).
 (198) F. A. Long, J. G. Pritchard, and F. E. Stafford, *J. Amer. Chem. Soc.*, **79**, 2362 (1957).
 (199) E. Whalley, *Advan. Phys. Org. Chem.*, **2**, 124 (1964).
 (200) E. Whalley, *Trans. Faraday Soc.*, **55**, 798 (1959).
 (201) F. A. Long and M. A. Paul, *Chem. Rev.*, **57**, 956 (1957).
 (202) L. J. Heidt and C. B. Purves, *J. Amer. Chem. Soc.*, **60**, 1206 (1938).
 (203) L. J. Heidt and C. B. Purves, *ibid.*, **66**, 1385 (1944).
 (204) C. E. Ballou, *Advan. Carbohydr. Chem.*, **9**, 59 (1954).
 (205) G. Wagner and P. Nuhn, *Pharmazie*, **21**, 205 (1966).

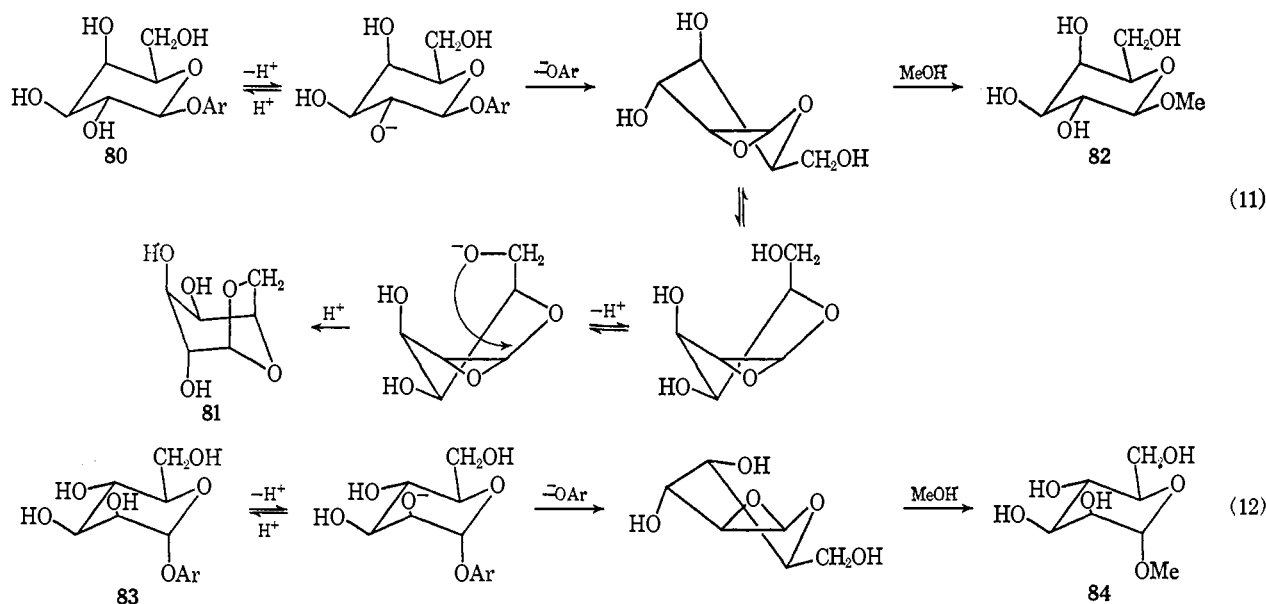

and those with an electron-withdrawing substituent in the aryl group are cleaved quite rapidly (see Table XXX).^{124, 125, 208, 207} Glycosides with a hydroxyl group at C(2) *trans* to the aglycon react more rapidly than their *cis* isomers and when they are also β -glycosides they frequently yield 1,6-anhydrides.²⁰⁸⁻²¹⁵

Table XXX

First-Order Rate Constants for the Alkaline Hydrolysis of Some Substituted Phenyl β -Glucopyranosides in Aqueous Sodium Hydroxide

Substituent	$10^7 k$ (sec^{-1}) for α -glucosides ^a	$10^6 k$ (sec^{-1}) for β -glucosides ^b
None	1	4.23
<i>o</i> -Me	0.3	1.93
<i>m</i> -Me	0.3	3.20
<i>p</i> -Me	0.5	1.60
<i>o</i> -Pr- <i>i</i>	...	0.854
<i>p</i> -Pr- <i>i</i>	...	1.25
<i>o</i> -Bu- <i>t</i>	...	0.228
<i>p</i> -Bu- <i>t</i>	...	1.12
2,4-Me ₂	...	0.924
2,6-Me ₂	...	1.92
<i>o</i> -MeO	...	12.7
<i>m</i> -MeO	1.1	10.5
<i>p</i> -MeO	...	15.7
<i>o</i> -Cl	...	384
<i>m</i> -Cl	1.5	32.8
<i>p</i> -Cl	3.2	14.9
<i>o</i> -NO ₂	...	>80,000
<i>m</i> -NO ₂	178	246
<i>p</i> -NO ₂	$c \ 3 \times 10^5$	$c \ 8000$

^a In 3.9 M NaOH at 70°, ¹²⁵ $\rho = 2.8$. ^b In 4 M NaOH at 60°, $\rho = 2.48$.

Thus *p*-nitrophenyl β -D-galactopyranoside (80) on treatment with sodium methoxide in methanol yields 1,6-anhydrogalactose (81, 76.3%) and methyl β -D-galactopyranoside (82, 7.9%), but *p*-nitrophenyl α -D-mannopyranoside (83) yields just methyl α -D-mannopyranoside (84, 88.3%).²¹⁴ It was therefore suggested^{208, 214} that neighboring group participation by the ionized hydroxyl group at C(2) occurs to yield an epoxide and that when this has the right configuration it reacts with participation by the hydroxyl group at C(6) (eq 11) but that otherwise normal ring opening occurs (eq 12). Support for this interpretation comes from qualitative observations that phenyl 2-*O*-methyl and 2,3-di-*O*-methyl (but not 3-*O*-methyl) β -D-glycoside are unreactive and the more recent quantitative measurements of the rates of reaction of *p*-nitrophenyl 2-*O*-methyl β -D-glucopyranoside,^{147c} β -D-galactopyranoside, and α -D-mannopyranoside (see, *e.g.*, Table XXXI).²¹⁴ These reactions are first order in glycoside and at low concentration first order in hydroxide, as are those of the parent glycosides,^{219a} but occur much more slowly than the latter. Further, tri-*O*-

Table XXXI

Second-Order Rate Constants for the Reactions of *p*-Nitrophenyl Glycosides with Aqueous Sodium Hydroxide at 55°²¹⁴

Glycoside	$10^6 k$, $l. \text{ mole}^{-1}$ sec^{-1}
β -D-Galactoside	416
2- <i>O</i> -Methyl β -D-galactoside	1.26
α -D-Mannoside	3090
2- <i>O</i> -Methyl α -D-mannoside	1.65

(210) E. M. Montgomery, N. K. Richtmeyer, and C. S. Hudson, *ibid.*, 65, 1848 (1943).

(211) E. M. Montgomery, N. K. Richtmeyer, and C. S. Hudson, *ibid.*, 65, 3 (1943).

(212) E. Zissis and N. K. Richtmeyer, *J. Org. Chem.*, 26, 5244 (1961).

(213) J. W. Pratt and N. K. Richtmeyer, *J. Amer. Chem. Soc.*, 79, 2597 (1957).

(214) R. C. Gasman and D. C. Johnson, *J. Org. Chem.*, 31, 1830 (1966).

(215) (a) E. M. Montgomery, N. K. Richtmeyer, and C. S. Hudson, *ibid.*, 10, 194 (1945); (b) G. Wagner and H. Frenzel, *Pharmazie*, 8, 415 (1967).

(206) J. H. Fisher, W. L. Hawkins, and H. Hibbert, *J. Amer. Chem. Soc.*, 63, 3031 (1941).

(207) (a) A. Dyfverman and B. Lindberg, *Acta Chem. Scand.*, 4, 878 (1950); (b) E. Tomita, *Yakugaku Zasshi*, 87, 490 (1967).

(208) C. M. McCloskey and G. H. Coleman, *J. Org. Chem.*, 10, 184 (1945).

(209) E. M. Montgomery, N. K. Richtmeyer, and C. S. Hudson, *J. Amer. Chem. Soc.*, 64, 1483 (1942).

acetyl-1,2-anhydro- α -D-glucose yields 1,6-anhydroglucose on treatment with alkali.^{207a, 210b}

p-Nitrophenyl β -D-galactoside and α -D-mannoside yield a small amount (<15%) of *p*-nitroanisole with sodium methoxide which indicates that there is some aryl-oxygen fission, and this is probably the major reaction pathway with their 2-*O*-methyl derivatives.²¹⁴

The effects of adding hydrogen peroxide on the rates of reaction in aqueous sodium hydroxide are in agreement with these mechanisms. According to Pearson and Edgington the hydroperoxide anion is a better nucleophile but a weaker base than the hydroxide ion so that the rate of a reaction in which OH^- is acting as a nucleophile should be increased by the addition of hydrogen peroxide, but that of one in which it is acting as a base should be decreased.²¹⁷ It was found that the rates of reaction of the galactoside and mannoside were decreased by the addition of hydrogen peroxide, but those of their 2-*O*-methyl derivatives strongly increased.²¹⁴

The relative rates of reaction of phenyl β -D-glucoside, galactoside, and xyloside in 4 *M* NaOH at 80° are 1:1.77:2.61,²¹⁸ and so the effect on the rate of varying the sugar is not very large.

Aryl 6-deoxy-6-thio- β -D-glucosides and -galactosides react similarly to their oxygen analogs with alkali and form 1,6-anhydro-6-thio derivatives.²¹⁹

Phenyl α -D-sedoheptuloside (85) reacts very rapidly with NaOH to yield sedoheptulose and with NaOMe to yield methyl α -D-sedoheptuloside. No 2,7-anhydrosedoheptulose could be detected.²²⁰ Participation by the hydroxyl at C(3) rather than by that at C(7) therefore occurs. In contrast, phenyl α -D-gluco- and mannoheptuloside (86 and 87) react much more slowly, but both yield 2,7-anhydro compounds with NaOH. It was suggested that these were formed either by direct participation by the hydroxyl at C(7) or by successive prior participations by the hydroxyls at C(1) and C(3) and C(3) and C(1), respectively.^{221, 222}

The alkaline fission of aryl glycosides with a hydroxyl group at C(2) *cis* to the aglycon proceeds by at least four different mechanisms: (i) nucleophilic substitution by OH^- on aromatic carbon with aryl-oxygen fission; (ii) nucleophilic substitution at C(1) of the sugar with glycosyl-oxygen fission; (iii) neighboring group participation by the ionized hydroxyl group at C(6) (*e.g.*, as with phenyl α -D-galactoside); (iv) neighboring group participation by an ionized hydroxyl group at C(4) (*e.g.*, as with phenyl β -D-mannoside).

It has been suggested that aryl α -D-glucopyranosides are cleaved by alkali with aryl-oxygen fission.¹²⁵ This is most likely with those containing strongly electron-withdrawing substituents (*e.g.*, $-\text{NO}_2$), but the rates of reaction of the unsub-

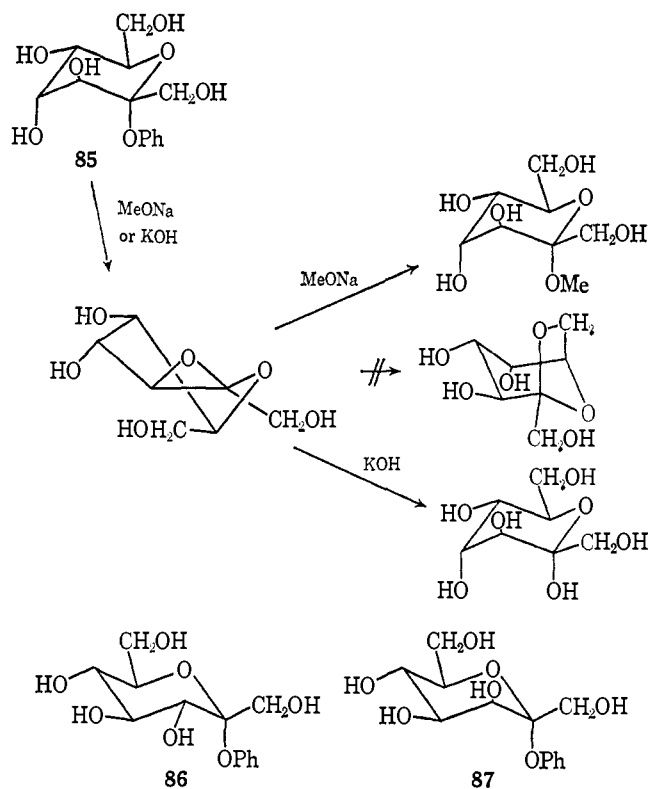

stituted compound and those containing electron-releasing substituents seem rather high (see Table XXX) for them to be reacting by an aromatic nucleophilic substitution, and displacement on the glucosyl carbon seems more likely. Some support for this interpretation comes from the Hammett $\rho\sigma$ plot in which the point for the *p*-nitrophenyl compound falls well above the line defined by the points for the other substituents even when the σ_p^- constant is used (see figure on p 4291 of ref 125), whereas with the β -glucosides it falls on this line (see Figure 1 of ref 124). Unfortunately no tracer studies have been reported for these reactions.

Although aryl α -D-glucosides do not apparently yield 1,6-anhydroglucose on treatment with alkali,²¹¹ phenyl α -D-galactoside slowly yields 1,6-anhydrogalactose in 85% yield²¹¹ and thus must be reacting with participation by the ionized hydroxyl group at C(6) (eq 13). The formation of 1,6-anhydro-

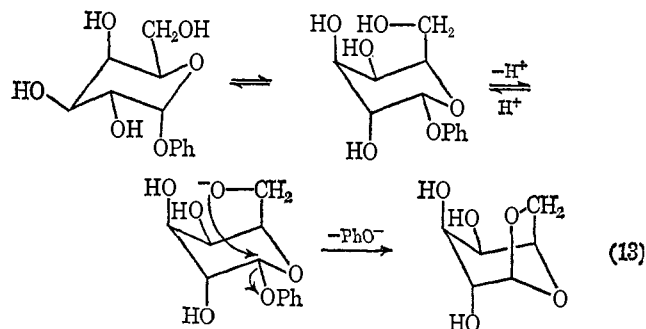

galactose would be expected to occur more readily than that of 1,6-anhydroglucose since in the former the hydroxyl group at C(4) is equatorial but in the latter it is axial.

Phenyl β -D-mannoside yields 1,6-anhydromannose in 57% yield on treatment with alkali.²⁰⁹ This cannot result from a direct displacement of a phenoxide ion by the hydroxyl at C(6) or C(2) since these are both *cis* to the phenoxy group. In fact, the only hydroxyl group which is situated suitably for partici-

(216) (a) The claim in ref 214 that the results of Dyfverman and Lindberg^{207a} indicate that the reaction of *p*-chlorophenyl β -D-glucoside in aqueous alkali is of order 0.044 with respect to OH^- is incorrect. According to calculations by the reviewer, the results in fact indicate that the order is approximately 1.05. (b) M. P. Bardolph and G. H. Coleman, *J. Org. Chem.*, 15, 169 (1950).

(217) R. G. Pearson and D. N. Edgington, *J. Amer. Chem. Soc.*, 84, 4607 (1962).

(218) B. N. Stepanenko and O. G. Serdyuk, *Dokl. Akad. Nauk SSSR*, 154, 877 (1964).

(219) R. L. Whistler and P. A. Seib, *Carbohydr. Res.*, 2, 93 (1966).

(220) E. Zissis and N. K. Richtmeyer, *J. Org. Chem.*, 30, 462 (1965).

(221) L. C. Stewart, E. Zissis, and N. K. Richtmeyer, *Chem. Ber.*, 89, 535 (1956).

(222) E. Zissis, L. C. Stewart, and N. K. Richtmeyer, *J. Amer. Chem. Soc.*, 79, 2593 (1957).

pation is that at C(4), and intramolecular displacement by this would yield 1,4-anhydromannose (88) (see also ref 223). A concerted displacement by the hydroxyl group at C(6) of this compound to yield 1,6-anhydromannose is not very likely for stereochemical reasons, and so a nonconcerted process involving a carbonium ion as shown in eq 14 seems most reasonable.

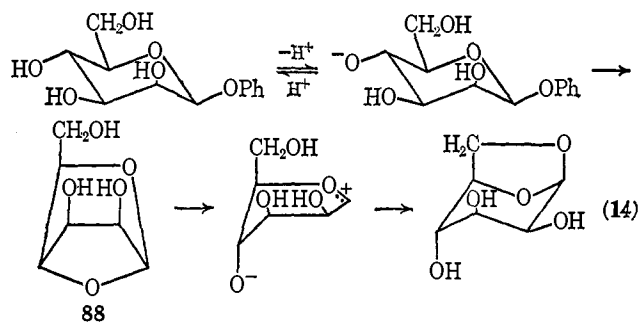

The interesting observation has been made that the products of the reaction of *p*-nitrophenyl 2-deoxy- α -D-glucopyranosides depend on the concentration of alkali.²²⁴ With 0.05 *M* KOH at 95° the only product reported was 1,6-anhydro-2-deoxyglucose, but in 0.001 *M* KOH 2-deoxyglucose was formed along with some 3,6-anhydro-2-deoxyglucose which it is known to yield on treatment with alkali. In strong alkali then there is participation by the C(6) hydroxyl group, but since the position of bond fission is not known it is not possible to decide if the reaction in dilute alkali involves glycosyl- or aryl-oxygen fission. The rate of reaction of *p*-nitrophenyl 2-deoxy- α -D-glucoside in 0.05 *M* KOH is about 100 times slower than that of *p*-nitrophenyl α -D-glucoside. Since the latter compound probably reacts by attack of OH^- on aromatic carbon whereas, under these conditions, the former compound does not, this difference in rate must result from the α -D-glucopyranosyloxy anion being a better leaving group than the 2-deoxy- α -D-glucopyranosyloxy anion, as would be expected from the electron-withdrawing inductive effect of the hydroxyl group.

The vinyl glucosides behave similarly to the phenyl glucosides on treatment with alkali with the β anomer, but not the α , yielding 1,6-anhydroglucose.²²⁵

Aryl β -thioglucosides^{215, 226} and β -selenoglucosides²²⁷ also yield 1,6-anhydroglucose on treatment with alkali. The relative rates of reaction of the phenyl glucosides are Se:S:O = \sim 300:2:1 and of the *p*-nitrophenyl glucosides Se:S:O = 5:1:25,²²⁷ suggesting that the ρ values for the reactions of the seleno- and thioglucosides are much less negative than that for the oxygen glucosides.

Yet another mechanism of fission is found with *p*-hydroxybenzyl glycosides, the most thoroughly studied of which is dhuririn (*p*-hydroxy-L-mandelonitrile β -D-glucopyranosides (89)).²²⁸ The rate is proportional to the concentration of glycoside with the phenolic hydroxyl group ionized, and the reaction was formulated as shown in eq 15. *o*- and *p*-hydroxybenzyl β -D-glucosides react similarly but more slowly, and indeed

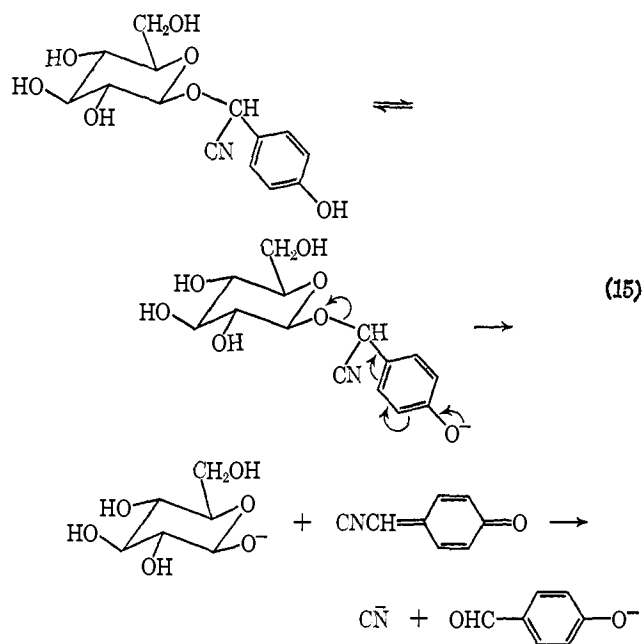

this mode of fission appears to be general for *p*-hydroxybenzyl ethers.^{229, 230}

The products from the alkaline fission of alkyl glycosides are not well characterized since one of the possible sets of products, the 1,6-anhydroaldoses, are hydrolyzed more rapidly²³¹ than the alkyl glycosides themselves react, and another, the free aldoses, undergo extensive degradation and rearrangement under the violent conditions used. The kinetics have been studied by deionizing the reaction solutions and determining the reacted glycoside by weighing it or polarimetrically (see Table XXXII).²³²⁻²³⁵ The greater rates of

Table XXXII

First-Order Rate Constants for the Reactions of Methyl Glycopyranosides with 10% Sodium Hydroxide at 170°

Methyl glycoside <i>o</i> ,	Relationship between OCH ₃ and C(2)-hydroxyl group	10 ⁷ <i>k</i> , sec ⁻¹	
		Pyranoside ^a	Furanoside ^a
α -D-Glucose	<i>cis</i>	6.4 ^b	
β -D-Glucose	<i>trans</i>	16	>640
2-O-Methyl α -D glucose	...	5.1	
2-O-Methyl β -D glucose	...	7.7	
α -D-Galactose	<i>cis</i>	6.4	50
β -D-Galactose	<i>trans</i>	36	180
α -D-Mannose	<i>trans</i>	18	190
β -D-Mannose	<i>cis</i>	7.0	
α -D-Xylose	<i>cis</i>	7.7	52
β -D-Xylose	<i>trans</i>	37	>640
α -L-Arabinose	<i>trans</i>	64	201
β -L-Arabinose	<i>cis</i>	6.4	

^a See footnote to Table IX. ^b Revised value; cf. ref 233.

(223) R. U. Lemieux, ref 36a, Part 2, p 762.

(224) R. J. Ferrier, W. G. Overend, and A. E. Ryan, *J. Chem. Soc.*, 3484 (1965).

(225) T. D. Perrine, C. P. J. Glaudemans, R. K. Ness, J. Kyle, and H. G. Fletcher, *J. Org. Chem.*, **32**, 664 (1967).

(226) G. Wagner and M. Wagler, *Arch. Pharm. (Weinheim)*, **297**, 358 (1964).

(227) G. Wagner and P. Nuhn, *ibid.*, **298**, 686 (1965).

(228) C.-H. Mao and L. Anderson, *J. Org. Chem.*, **30**, 603 (1965).

(229) S. Larsson and B. Lindberg, *Acta Chem. Scand.*, **16**, 1757 (1962).

(230) A. von Wacek and H. Kesselring, *Ann. Chem.*, **693**, 171 (1966).

(231) E. Dryselius, B. Lindberg, and O. Theander, *Acta Chem. Scand.*, **11**, 663 (1957).

(232) E. Dryselius, B. Lindberg, and O. Theander, *ibid.*, **12**, 340 (1958).

(233) J. Janson and B. Lindberg, *ibid.*, **13**, 138 (1959).

(234) J. Janson and B. Lindberg, *ibid.*, **14**, 2051 (1960).

(235) R. D. Brooks, *Dissertation Abstr.*, **27B**, 402 (1966).

reaction of the pyranosides with the hydroxyl group at C(2) *trans* to the glycosidic methoxyl group were ascribed to neighboring group participation, but if this is correct the anchimeric assistance is slight since the difference in rate between *cis* and *trans* isomers is small, and methyl 2-O-methyl β -D-glucoside does not react much slower than methyl β -D-glucoside itself.

Furanosides are hydrolyzed appreciably faster than pyranosides and the 1,2-*trans* isomers faster than the 1,2-*cis* isomers, which may be the result of neighboring group participation.²³⁴

Neighboring group participation by a group in the aglycon sometimes occurs as in the reactions of cellobiitol (90), lactitol, and maltitol which yield, *inter alia*, 1,4-anhydroglucitol (see eq 16)^{231, 236a} and possibly also in those of the 2-hydroxyethyl glucosides which occur two to three times more rapidly than those of the corresponding 2-methoxyethyl glucosides²³³ (see also ref 236b).

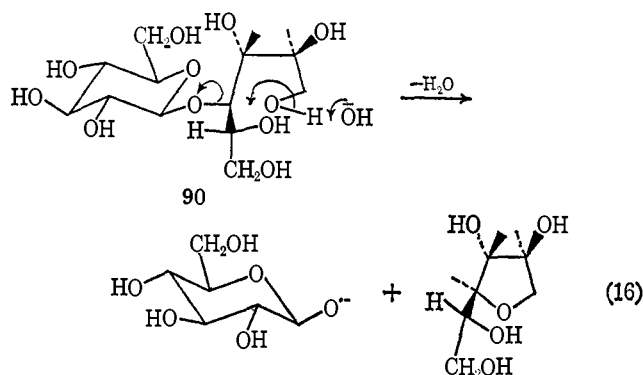

V. Enzymically Catalyzed Hydrolysis of Glycosides

A. INTRODUCTION

Hydrolyses catalyzed by glycosidases resemble acid-catalyzed hydrolyses of simple alkyl and aryl glycosides in that cleavage of the glycosyl (C(1))–oxygen bond occurs. This has so far been demonstrated with β -amylases of barley²³⁷ and sweet potato,²³⁸ α -amylases of hog pancreas²³⁸ and *B. subtilis*,^{237, 238} glucamylase from *A. niger*,²³⁹ α -glucosidase of brewers yeast,²⁴⁰ β -glucosidase of almond emulsin²⁴⁰ (see also ref 241), lysozyme,²⁴² β -galactosidase of *E. coli*,²⁴³ and β -glucuronidase from calf liver.²⁴⁴

These reactions are therefore formally nucleophilic substitutions at C(1) of the glycosides, and glycosidases may be divided conveniently into two classes according to whether the hydrolysis (or transfer) reactions which they catalyze proceed with inversion or retention of configuration. The former class includes β -amylases,^{245–249} taka-maltase,²⁵⁰ and

the glucamylases from *A. niger*^{251, 252} and *Rh. delemar*,^{253, 254} and the latter α -amylases,^{245, 247, 255–258} almond emulsin β -glucosidase,^{252, 259} β -galactosidase from *E. coli* (*cf.* ref 260, 261), cellulase²⁶² and aryl β -glucosidase²⁶³ from *M. verrucaria*, yeast invertase,^{264–266} pullulanase,²⁶⁷ lysozyme,^{242, 268} brewers yeast α -glucosidase,^{269a} and pancreatic maltase.^{250, 269b}

These two types of behavior presumably reflect important differences in mechanism which have frequently been speculated upon. In nonenzymic reactions retention of configuration in a nucleophilic displacement on saturated carbon is generally considered to require a special explanation which may involve neighboring group participation, steric hindrance to rearside approach, torsional effects, or an S_Ni mechanism. In glycosidase-catalyzed hydrolyses, two main types of explanation have been invoked to explain retention of configuration. In the first the reaction is formulated as involving either nucleophilic participation by a group in the substrate or by a group in the enzyme. The latter process would yield a glycosyl enzyme²⁷⁰ of inverted configuration which on reaction with water or another hydroxylic compound would yield a product with the same configuration as the starting glycoside. This has been termed a double-displacement mechanism by Koshland.^{271–273a} It must be emphasized, however, that at present there is no corroborating evidence for the intervention of a glycosyl enzyme in any glycosidase-catalyzed reaction.^{273b}

In the other explanation, it is proposed that electrostatic shielding or ion pairing by an ionized group of the enzyme

(245) R. Kuhn, *Ann. Chem.*, **443**, 1 (1925).

(246) H. von Euler and K. Hellenberg, *Z. Physiol. Chem.*, **139**, 24 (1924).

(247) G. G. Freeman and R. H. Hopkins, *Biochem. J.*, **30**, 451 (1936).

(248) J. A. Thoma and D. E. Koshland, *J. Biol. Chem.*, **235**, 2511 (1960).

(249) J. Robyt and D. French, *Arch. Biochem. Biophys.*, **104**, 338 (1964).

(250) E. Ben-Gershom and J. Leibowitz, *Enzymologia*, **20**, 148 (1958).

(251) C. E. Weil, R. J. Burch, and J. W. van Dyk, *Cereal Chem.*, **31**, 150 (1954).

(252) J. E. G. Barnett, W. T. S. Jarvis, and K. A. Munday, *Biochem. J.*, **103**, 699 (1967).

(253) S. Ono, K. Hiromi, and Z. Hamauzu, *J. Biochem. (Tokyo)*, **57**, 34 (1965).

(254) Z. Hamauzu, K. Hiromi, and S. Ono, *ibid.*, **57**, 39 (1965).

(255) R. Kuhn, *Ber.*, **57**, 1965 (1924).

(256) J. A. Thoma, J. Wakim, and L. Stewart, *Biochem. Biophys. Commun.*, **12**, 350 (1963).

(257) J. A. Thoma and J. Wakim, *J. Theor. Biol.*, **19**, 297 (1968).

(258) Z.-I. Hamauzu, K. Hiromi, and S. Ono, *J. Biochem. (Tokyo)*, **57**, 42 (1965).

(259) R. Kuhn, *Z. Physiol. Chem.*, **127**, 234 (1923); **129**, 57 (1923).

(260) K. Wallenfels and O. P. Malhotra, *Enzymes*, **4**, 409 (1960).

(261) K. Wallenfels and O. P. Malhotra, *Advan. Carbohydr. Chem.*, **16**, 239 (1962).

(262) D. R. Whitaker, *Arch. Biochem. Biophys.*, **53**, 436 (1954).

(263) J. H. Hash and K. W. King, *J. Biol. Chem.*, **232**, 395 (1958).

(264) W. J. Whelan and D. M. Jones, *Biochem. J.*, **54**, xxxiv (1953).

(265) J. S. D. Bacon, *ibid.*, **50**, xviii (1952).

(266) A. I. Oparin and M. S. Bardinskaya, *Dokl. Akad. Nauk SSSR*, **89**, 531 (1953).

(267) K. Wallenfels and I. R. Rached, *Biochem. Z.*, **344**, 524 (1966).

(268) G. Lowe and G. Sheppard, unpublished work quoted by G. Lowe, G. Sheppard, M. L. Simnott, and A. Williams, *Biochem. J.*, **104**, 893 (1967); see also F. W. Dahlquist, C. L. Borders, G. Jacobson, and M. A. Raftery, *Biochemistry*, **8**, 694 (1969).

(269) (a) S. Chiba, S. Sugawara, T. Shimomura, and Y. Nakamura, *Agr. Biol. Chem. (Tokyo)*, **26**, 787 (1962); (b) D. E. Eveleigh and A. S. Perlin, *Carbohydr. Res.*, **10**, 87 (1969).

(270) K. Wallenfels and E. Bernt, *Ann. Chem.*, **584**, 63 (1953).

(271) D. E. Koshland, *Biol. Rev. Cambridge Phil. Soc.*, **28**, 416 (1953).

(272) D. E. Koshland in "The Mechanism of Enzyme Action," W. D. McElroy and B. Glass, Ed., Johns Hopkins Press, Baltimore, Md., 1954, p. 608.

(273) (a) D. E. Koshland, *Discussions Faraday Soc.*, **20**, 142 (1956); (b) see discussion by G. Legler, *Biochim. Biophys. Acta*, **151**, 728 (1968).

(236) (a) B. Lindberg, *Svensk Papperstid.*, **59**, 531 (1956); (b) J. D. Bu'Lock and H. Gregory, *J. Chem. Soc.*, 2280 (1960).

(237) M. Halpern and J. Leibowitz, *Biochem. Biophys. Acta*, **36**, 29 (1959).

(238) F. C. Mayer and J. Lerner, *J. Amer. Chem. Soc.*, **81**, 188 (1959).

(239) J. G. Fleetwood and H. Weigel, *Nature*, **196**, 984 (1962).

(240) C. A. Bunton, T. A. Lewis, D. R. Llewellyn, H. Tristram, and C. A. Vernon, *ibid.*, **174**, 560 (1954).

(241) S. S. Springhorn and D. E. Koshland, Abstracts, 128th National Meeting of the American Chemical Society, Minneapolis, Minn., Sept 1955, p. 37c.

(242) J. A. Rupley, *Proc. Roy. Soc.*, **B167**, 416 (1967).

(243) K. Wallenfels, O. P. Malhotra, H. Dahn, and H. Moll, unpublished results quoted by K. Wallenfels and O. P. Malhotra, *Advan. Carbohydr. Chem.*, **16**, 287 (1961).

(244) F. Eisenberg, *Fed. Proc.*, **18**, 221 (1959).

prevents attack from the α or β direction on the intermediate glycosyl cation.^{118, 257, 274-276} The most telling argument for this explanation and against the intervention of a glycosyl enzyme comes from a consideration of the pH dependence of V_{\max} of porcine pancreatic β -amylase and sweet potato β -amylase which have been interpreted as indicating that carboxylate and imidazolium act as catalytic groups with both enzymes.^{257, 274} It would appear then that a basic (or nucleophilic) group is required for the inverting β -amylase as well as the noninverting α -amylase. Since there is no need to postulate the intervention of a glycosyl enzyme in reactions catalyzed by the former, some other function must be found for the carboxylate group, and it was suggested that this acts by stabilizing the intermediate carbonium ion and transition state for its formation electrostatically by ion pairing. The similarity of the pH dependence of V_{\max} for both amylases may mean that the carboxylate group acts similarly with both, and the differences in the steric courses may result from a difference in the stereochemistry of the carbonium ion-carboxylate ion pairs which forces a water molecule to attack the carbonium ion in different directions.

At present it is not possible to say if this explanation can be extended to all glycosidases. With some, the basic group is thought to be an un-ionized one (*e.g.*, imidazole with β -galactosidase from *E. coli*; see section V.E), and if this is correct only an ion-dipole rather than an ion-ion interaction would be possible. This may favor formation of a glycosyl enzyme.

Several glycosidases have been found to catalyze the hydrolyses of aryl glycosides as well as those of their natural substrates. When this is so, it is possible to determine substituent effects on the rates and other kinetic parameters of the hydrolyses. This information could obviously be important evidence in the elucidation of the mechanism of hydrolysis of these substrates, although that of the hydrolysis of the natural substrates need not be the same. Nevertheless, in our present state of knowledge, information about the mechanism of the glycosidase-catalyzed hydrolysis of any substrate, natural or synthetic, is valuable, and if the mechanism of the hydrolysis of aryl glycosides could be determined it would provide a useful working hypothesis for the mechanism of the hydrolysis of the natural substrates.

An obvious question to ask about these substituent effects is whether there is any difference between inverting and non-inverting glycosidases and if indeed substituent effects are similar for different enzymes within each class. Unfortunately, extensive substituent effects have only been reported with five glycosidases so far. These are almond emulsin β -glucosidase, using aryl β -D-glucosides as substrates¹²⁴ (see also ref 277), Taka-amylase using aryl α -maltosides,²⁷⁸ brewers yeast α -glucosidase using aryl α -D-glucosides,²⁷⁹ lysozyme using aryl di-*N*-acetyl- β -chitobiosides,²⁸⁰ and locust-gut β -glucosidase using aryl β -D-glucosides.²⁸¹ The steric course of reactions

catalyzed by the first four of these enzymes is retention of configuration, but that of reactions catalyzed by the fifth is not known.

With almond emulsin β -glucosidase, Taka-amylase, lysozyme, and locust-gut β -glucosidase, the values of k_3 , the rate constant for breakdown of the enzyme-substrate complex, were increased by electron-withdrawing substituents in the aryl ring. Plots of $\log k_3$ or $\log k_{\text{cat}}$ against σ for the first three of these yielded ρ constants in the region 1-1.5; *i.e.*, intermediate between the ρ values obtained for the OH^- and H_3O^+ -catalyzed hydrolyses, which for aryl β -D-glucosides are +2.48 and -0.66 and for aryl α -maltosides, +2.51 and -0.25, respectively. This value of 1-1.5 is of the magnitude to be expected if the departure of the aryloxy group were general acid catalyzed. In the OH^- -catalyzed reaction the leaving group is unprotonated ArO^- , and in the H_3O^+ -catalyzed reaction it is completely protonated ArOH . In a general acid catalyzed reaction, however, a proton is partially transferred to the ArO group in the transition state, so that an intermediate ρ value would be reasonable.

The effect of substituents on k_3 for the hydrolysis of aryl β -D-glucosides catalyzed by locust-gut β -glucosidase appears to be similar, but a ρ value has not been reported.²⁸¹ The values of k_3 for the hydrolyses of aryl α -glucosides catalyzed by brewers yeast α -glucosidase show no sign of being correlated by the σ values. The effects of substituents are not large, however, and it is possible that the ρ value is close to zero and the correlation obscured by the errors of the measurements.

Less extensive studies have been carried out with other enzymes including the β -galactosidases of *E. coli* and calf intestine (*cf.* ref 260, 261).

B. LYSOZYME

Lysozyme from hens' egg white is a protein of molecular weight 14,388. Its amino acid sequence was determined independently by Jolles and by Canfield (see ref 282, 283) and its conformation in the crystalline state by Phillips and his coworkers.^{284, 285} It is the only glycosidase for which these properties are known.

Lysozyme destroys the cell walls of certain bacteria by catalyzing the hydrolysis of the carbohydrate component, a β -1,4-linked polysaccharide with alternate *N*-acetylglucosamine and *N*-acetylmuramic acid residues. β -1,4-Linked oligosaccharides of 2-acetamido-2-deoxyglucose containing four, five, and six residues (tetra-*N*-acetylchitotetraose, penta-*N*-acetylchitopentaose, and hexa-*N*-acetylchitohexaose) are convenient low molecular weight substrates,^{242, 286, 287} and the hydrolyses of tri-*N*-acetylchitotriose,²⁴² *p*-nitrophenyl di-*N*-acetylchitobioside,^{280, 288, 289} and tri-*N*-acetylchitotrioside²⁹⁰ are feebly catalyzed.

(282) P. Jolles, *Angew. Chem. Intern. Ed. Engl.*, **3**, 28 (1964).

(283) P. Jolles, *Proc. Roy. Soc.*, **B167**, 350 (1967).

(284) C. C. F. Blake, D. F. Koenig, G. A. Mair, A. C. T. North, D. C. Phillips, and V. R. Sarma, *Nature*, **206**, 757 (1965).

(285) C. C. F. Blake, G. A. Mair, A. C. T. North, D. C. Phillips, and V. R. Sarma, *Proc. Roy. Soc.*, **B167**, 365 (1967); D. C. Phillips, *Proc. Nat. Acad. Sci., U. S.*, **57**, 484 (1967).

(286) M. Wenzel, H. P. Lenk, and E. Schütte, *Z. Physiol. Chem.*, **327**, 13 (1961).

(287) J. A. Rupley, *Biochem. Biophys. Acta*, **83**, 245 (1964).

(288) T. Osawa, *Carbohydr. Res.*, **1**, 435 (1966).

(289) G. Lowe, *Proc. Roy. Soc.*, **167**, 431 (1967); G. Lowe and G. Sheppard, *Chem. Commun.*, 529 (1968).

(290) T. Osawa and Y. Nakazawa, *Biochem. Biophys. Acta*, **130**, 56 (1966).

(274) D. E. Koshland, J. A. Yankeelov, and J. A. Thoma, *Fed. Proc.*, **21**, 1031 (1962).

(275) C. A. Vernon and B. Banks, *Biochem. J.*, **86**, 7P (1963).

(276) D. C. Phillips, *Sci. Am.*, **215**, (5), 78 (1966).

(277) C. Hansch, E. W. Deutsch, and R. N. Smith, *J. Amer. Chem. Soc.*, **87**, 2738 (1965).

(278) S. Matsubara, *J. Biochem. (Tokyo)*, **49**, 232 (1961).

(279) A. N. Hall, S. Hollingshead, and H. N. Rydon, *Biochem. J.*, **84**, 390 (1962).

(280) G. Lowe, G. Sheppard, M. L. Sinnott, and A. Williams, *ibid.*, **104**, 893 (1967).

(281) M. R. J. Morgan, *ibid.*, **102**, 45P (1967).

As expected, the hydrolysis proceeds with cleavage of a C(1)-oxygen bond of the substrate. This was demonstrated by carrying out the hydrolysis of tri-*N*-acetylchitotriose in ^{18}O -enriched water and showing that the products, di-*N*-acetylchitobiose and *N*-acetylglucosamine, only contained the label at position 1.²⁴²

In addition to determining the three-dimensional structure of the enzyme, Phillips and his coworkers determined the structure of a complex between the enzyme and tri-*N*-acetylchitotriose, which besides being a poor substrate is also an inhibitor. The active site was thus identified and shown to be in a hydrophobic cleft of the enzyme made up largely of side chains of amino acids such as valine, phenylalanine, leucine, and tryptophan.^{291, 292}

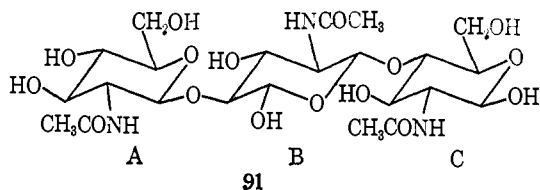

In the enzyme-inhibitor complex hydrogen bonding occurs between the NH and CO group of the *N*-acetyl side chain of residue C (see 91) and the CO and NH of amino acids 107 and 59, respectively, and between O(6) and O(3) and the indole NH groups of tryptophan-62 and -63. O(6) of residue B and the NH group of residue A are hydrogen bonded to the side chain of aspartic acid-101. Presumably this hydrogen bonding constitutes part of the binding force between enzyme and inhibitor, and it seems likely that similar bonding occurs between enzyme and substrate. Interactions between hydrophobic portions of the substrate (*e.g.*, the CH_3 portion of the acetamido groups) and the components of the hydrophobic slit of the enzyme are also probably important in binding the substrate.

The only functional groups in the vicinity of the inhibitor in the enzyme-inhibitor complex which are available for catalytic action are the carboxylic acid groups of glutamic acid-35 and aspartic acid-52. There is evidence that some of the carboxylic acid groups of lysozyme have abnormally high $\text{pK}'\text{s}$,²⁹³ and it has been suggested that one of these is that of glutamic acid-35.¹¹⁸ It would be mainly un-ionized in the pH region 5-6 and able to provide general acid catalysis for the rupture of the glycosidic bond^{118, 276, 289, 280} (see eq 17-19). This suggestion is supported by the observation¹⁷⁷⁻¹⁷⁹ that a suitably oriented internal carboxylic acid group provides intramolecular general acid catalysis, analogous to this "intracomplex" general acid catalysis (see section II.B).

Three functions have been suggested for the carboxylic acid group of Asp-52 which is thought to have a normal pK and act in its ionized form. These are (i) to act as a nucleophilic catalyst and form a glycosyl-enzyme intermediate (eq 17);^{280, 289} (ii) to stabilize the glycosyl cation by an electrostatic interaction (eq 18)^{276, 118} similar to that proposed for α -amylases^{257, 274} (this type of explanation which is at present the most favored is discussed more fully for amylases in section V.A); (iii) to provide general base catalysis for neighboring

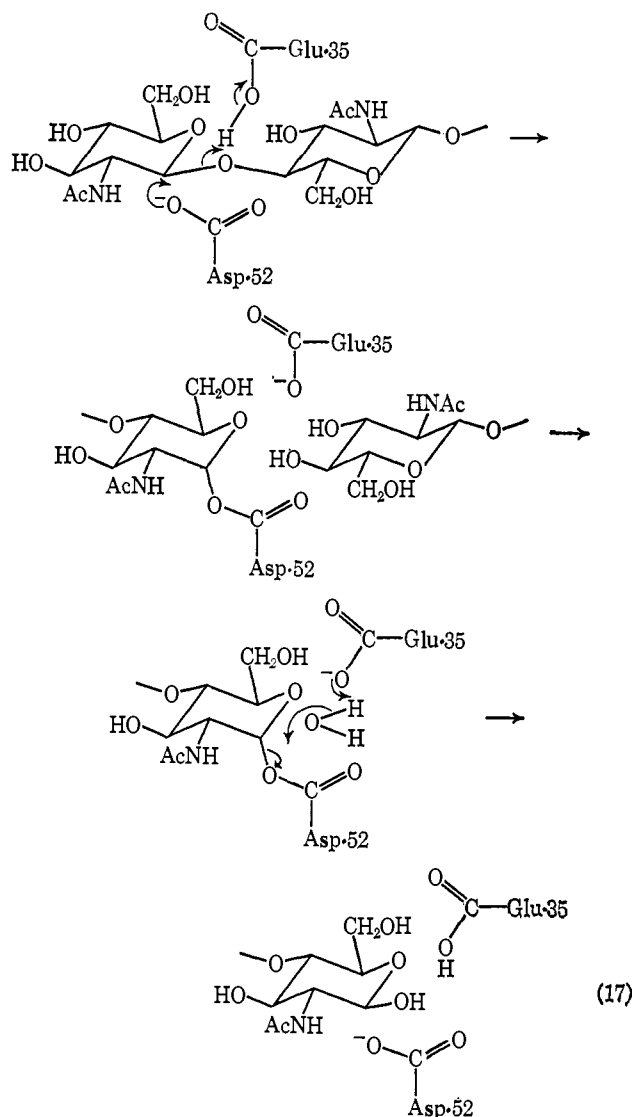

group participation by the amido group of the substrate (eq 19).^{289, 294a}

It may be possible to distinguish experimentally between proposal i on the one hand and ii and iii on the other by finding whether or not the reaction proceeds *via* a glycosyl-enzyme intermediate. Unfortunately no experiments designed to detect a glycosyl-enzyme intermediate have been reported so far.

The conceptual distinction between i and ii is a fine one. Several examples of nucleophilically assisted reactions of acetals have been reported^{188, 189, 294b, 295} and particularly relevant is the report that the carboxylic acid group of phthaldehydic acid diethyl acetal provides nucleophilic assistance for the rupture of the acetal bond in 82% aqueous dioxane (eq 20) but not in water.²⁹⁵ If this acetal, which should form a much more stable carbonium ion than a glycoside, reacts with nucleophilic assistance in the presence of a properly oriented carboxyl group, it seems likely that a glycoside could

(291) L. N. Johnson and D. C. Phillips, *Nature*, 206, 761 (1965).

(292) C. C. F. Blake, L. N. Johnson, G. A. Mair, A. C. T. North, D. C. Phillips, and V. R. Sarma, *Proc. Roy. Soc.*, B167, 378 (1967).

(293) J. W. Donovan, M. Laskowski, and H. A. Scheraga, *J. Amer. Chem. Soc.*, 82, 2154 (1960).

(294) (a) It has been argued (ref 280, 289a, 297b) that this type of process is not possible since the carboxyl group of Asp-52 is not oriented properly with respect to the amido group to effect direct transfer of a proton. However, this consideration does not exclude general base catalysis involving proton transfer through a chain of water molecules. There is good evidence for this type of process in other general base catalyzed reactions (*cf.* p 455). (b) J. C. Speck, D. J. Rynbrandt, and I. H. Kochevar, *J. Amer. Chem. Soc.*, 87, 4979 (1965).

(295) E. Anderson and B. Capon, in preparation.

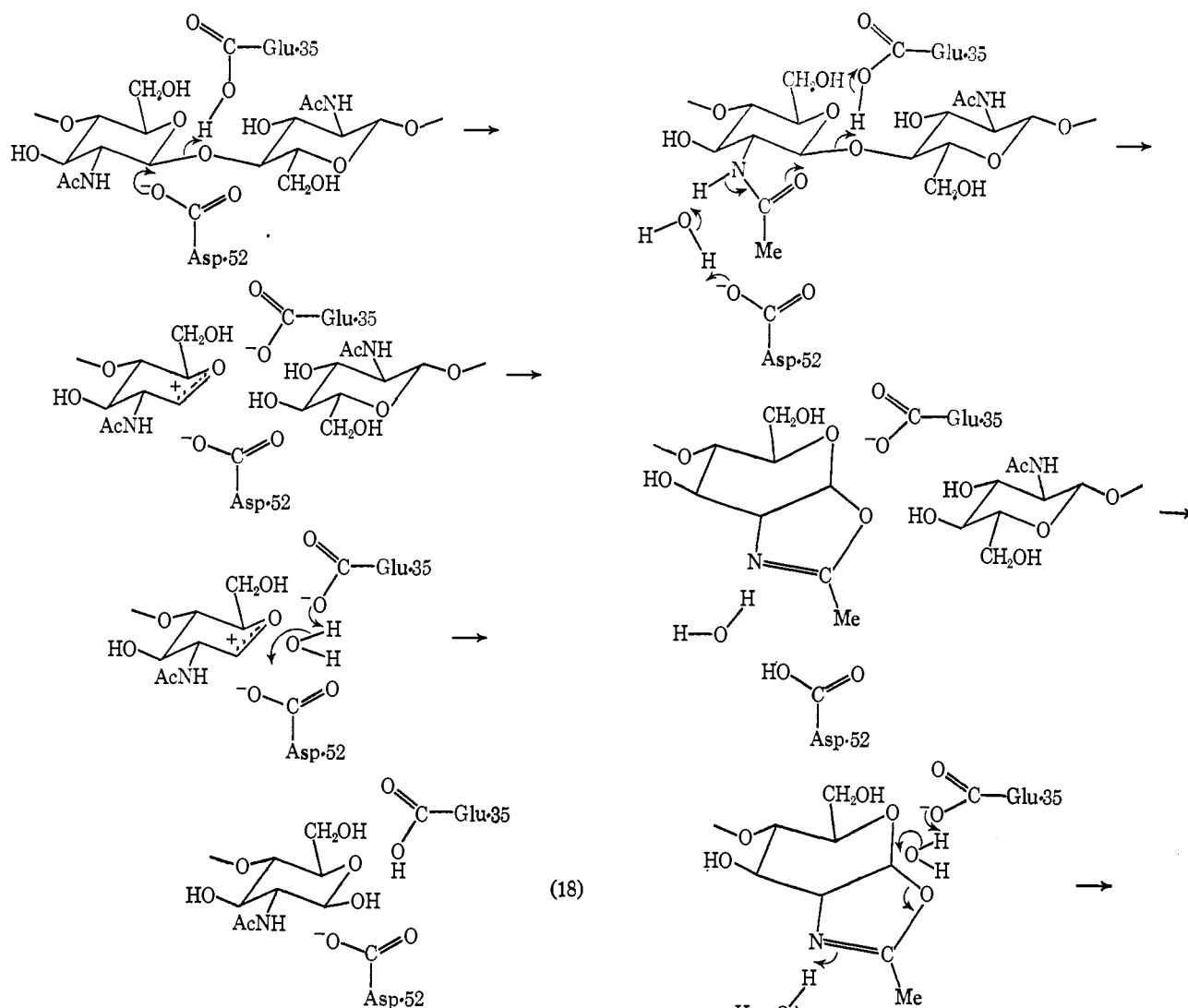

do so as well. It has been argued¹¹⁸ that a covalent bond cannot be formed between substrate and enzyme because it would not be permitted by the rigid geometry of the protein. This proposal cannot be assessed until the necessary book-keeping of energy terms has been carried out, but on the credit side for the formation of a glycosyl-enzyme intermediate, it should be noted that if the reaction did involve a carboxylate-stabilized carbonium ion, these charged groups would be at least 3 Å apart (*cf.* ref 113). Hence the energy to be gained by forming a glycosyl enzyme would be equal to the energy of dissociation of the carbon-oxygen bond plus the energy necessary to separate the ions to a distance of 3 Å or more, and probably at least 30–40 kcal mole⁻¹. This energy would therefore be available to distort the protein to allow it to form a glycosyl enzyme.

It has been emphasized by Perutz (see also ref 274) that part of the catalytic efficiency of lysozyme may result from the reaction taking place in the hydrophobic slit. He writes, "Organic solvents have the advantage over water of providing a medium of low dielectric constant, in which strong electrical interactions between reactants can take place. The non-polar interior of enzymes provide the living cell with the equivalent of the organic solvents used by the chemists. The substrate may be drawn into a medium of low dielectric constant in which strong electrical interactions between it and specific polar groups of the enzyme can occur. The non-polar medium

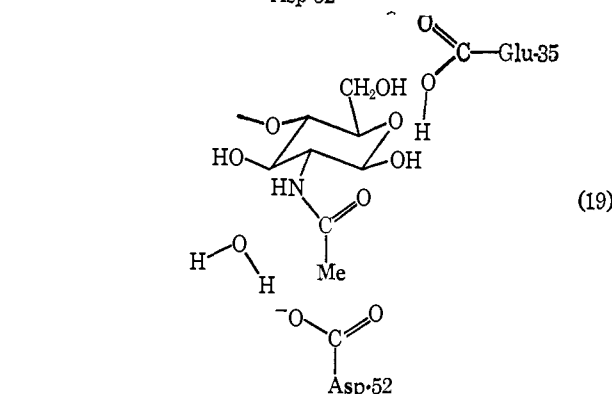

of the cleft of lysozyme increases the strength of the interaction between the carbohydrate and the carboxylic acid group of the enzyme."²⁹⁶ It is therefore of interest and relevance that the carboxylate group of phthalaldehydic acid diethyl acetal provides considerable assistance for the rupture of the acetal bond in aqueous dioxane but not in water. In as much as the

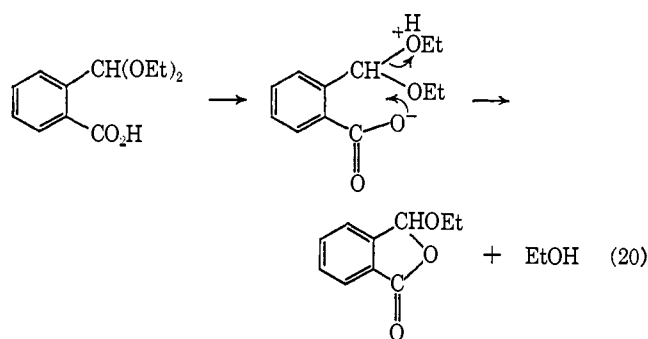

environment of the catalytic group and substrate in the hydrophobic cleft of lysozyme is approximated better by aqueous dioxane than by water, this result supports the views expressed by Perutz. In the reviewer's opinion, however, the reduction in specific interactions between catalytic groups and solvent which take place on going from water to a less polar solvent or environment are probably more important than the lowering of the dielectric constant. An increase in the free energy of the initial state results, and the catalytic groups which are less strongly hydrogen bonded are more available to interact with the substrate.

Another factor which may contribute toward the catalytic efficiency of lysozyme, but whose importance is difficult to assess, is that, when the substrate is bound to the enzyme, the conformation of the 2-acetamido-2-deoxyglucose unit on which substitution is going to take place may be distorted toward a half-chair which is the most favorable conformation for a carbonium ion or S_N2 transition state.^{113, 292}

Proposal iii finds analogy in several nonenzymic reactions of derivatives of 2-acetamido-2-deoxyglucose. Fletcher and Inch^{297a} showed that 2-acetamido-1-*O*-acetyl- and 1-*O*-benzoyl-3,4,6-tri-*O*-benzyl-2-deoxy- β -D-glucohexopyranose undergo hydrolysis with participation by the amido group, and Bruice and Piskiewicz have shown that the acid-catalyzed hydrolysis of methyl 2-acetamido-2-deoxy- β -D-glucoside and the neutral hydrolysis of *o*- and *p*-nitrophenyl β -D-glucoside proceed similarly.^{297b} Particularly relevant, however, is the report^{179b, 297c} that *o*-carboxyphenyl 2-acetamido-2-deoxy- β -D-glucoside is also hydrolyzed with participation by the amido group. In addition this reaction shows intramolecular general acid catalysis by the *o*-carboxyl group. The mechanism shown in 64b was proposed. Its analogy to the mechanism of eq 19 is obvious. It is also interesting that the methanolysis of this glycoside yields methyl β -D-2-acetamido-2-deoxyglucose.^{179b} The normal course of substitution at C(1) of a β -2-acetamido-2-deoxyglucoside may therefore be retention of configuration, and hence control by a functional group of the enzyme is not a necessary hypothesis to explain the steric course of lysozyme-catalyzed reactions.

Clearly these results on model systems cannot give us a definite answer on the mechanism of the enzymically catalyzed reaction, but they do give us some idea as to what processes are feasible, and these results show that general acid catalysis by an un-ionized carboxyl group, nucleophilic assistance by an ionized carboxyl group, and nucleophilic assistance by a neighboring amido group are all reasonable processes to postulate. To decide whether either of the last two is occurring

or whether the carboxylate group of Asp-52 acts by stabilizing the glycosyl cation by ion pairing requires more work, however. Recently several ingenious attempts to solve these problems have been reported (see Addendum, p 498).

C. AMYLASES AND GLUCAMYLASES²⁹⁸⁻³⁰⁰

The most studied α -amylases are those from human saliva, hog pancreas, barley malt, *aspergillus oryzae* (Taka-amylase A), *B. subtilis* and *B. stearothermophilus*, soya bean,³⁰¹ and broad bean.^{302, 303} They possess the common property of catalyzing the hydrolysis of the α -1 \rightarrow 4 linkages of amylose in an apparently random manner to yield low molecular weight fragments, generally maltose and maltotriose (see ref 249, 304-310) with retention configuration. The first five of these enzymes have molecular weights of approximately 50,000 but the amylase from *B. stearothermophilus* has one of only 15,000. Their amino acid compositions have been tabulated and commented on by Fischer and Stein²⁹⁸ and by Pazur.³⁰⁰ Taka-amylase A also contains a few per cent of carbohydrate. This was originally considered to be bound to the protein through a glycosidic linkage to a serine residue.^{311, 312} Later, on the grounds that the rate of the acid-catalyzed fission of the carbohydrate moiety is similar to the rate of hydrolysis of an ester, it was suggested that the carbohydrate is joined by an ester linkage to a glutamic or aspartic acid residue.³¹³ More recently, however, an investigation of a glycopeptide obtained from the denatured enzyme by digestion with Pronase P, has shown that the carbohydrate, which consists of mannose, galactose, xylose, glucosamine, and *N*-acetylglucosamine, is linked to the protein through a glucosamine residue attached to the β -carboxyl group of aspartic acid *via* an amide bond as Ser-Asp-NH-carbohydrate.^{314a} The carbohydrate may be cleaved from the enzyme by periodate oxidation without affecting the enzymatic activity, but this change does affect the immunological specificity.³¹³ It has recently been shown that the carbohydrate residues of the glucamylases from *A. Niger* are attached by glycosidic linkages to serine and threonine hydroxyl groups of the protein.^{314b}

(298) E. H. Fischer and E. A. Stein, *Enzymes*, **4**, 313 (1960).

(299) D. French, *ibid.*, **4**, 345 (1960).

(300) J. H. Pazur in "Starch: Chemistry and Technology," Vol. 1, R. L. Whistler and E. F. Paschall, Ed., Academic Press, New York, N. Y., 1965, p 133.

(301) C. T. Greenwood, A. W. MacGregor, and E. A. Milne, *Carbohydr. Res.*, **1**, 229 (1965).

(302) C. T. Greenwood, A. W. MacGregor, and E. A. Milne, *Arch. Biochem. Biophys.*, **112**, 459 (1965).

(303) C. T. Greenwood, A. W. MacGregor, and E. A. Milne, *ibid.*, **112**, 466 (1965).

(304) J. A. Thoma in ref 300, p 178.

(305) J. Robyt and D. French, *Arch. Biochem. Biophys.*, **100**, 451 (1963).

(306) D. French and R. W. Youngquist, *Staerke*, **15**, 425 (1963).

(307) N. O. de Souza and A. Panek, *J. Chromatogr.*, **15**, 103 (1964).

(308) S. K. Dube and P. Nordin, *Arch. Biochem. Biophys.*, **99**, 105 (1962).

(309) C. T. Greenwood, A. W. MacGregor, and E. A. Milne, *Staerke*, **17**, 219 (1965).

(310) C. T. Greenwood and A. W. MacGregor, *J. Inst. Brew.*, **71**, 405 (1965).

(311) H. Hanafusa, T. Ikenaka, and S. Akabori, *J. Biochem. (Tokyo)*, **42**, 55 (1955).

(312) A. Tsugita and S. Akabori, *ibid.*, **46**, 695 (1959).

(313) J. H. Pazur, K. Kleppe, and E. M. Ball, *Arch. Biochem. Biophys.*, **103**, 515 (1963).

(314) (a) M. Anai, T. Ikenaka, and Y. Matsushima, *J. Biochem. (Tokyo)*, **59**, 57 (1966); (b) D. R. Lineback, *Carbohydr. Res.*, **7**, 106 (1968).

(297) (a) T. D. Inch and H. G. Fletcher, *J. Org. Chem.*, **31**, 1810 (1966); (b) D. Piszkiwicz and T. C. Bruice, *J. Amer. Chem. Soc.*, **89**, 6237 (1967); **90**, 5844 (1968); (c) *ibid.*, **90**, 2156 (1968).

Most, possibly all, α -amylases are metalloenzymes requiring calcium for enzymatic activity. All the calcium may be removed from the α -amylases of *B. subtilis* and human saliva most conveniently by electro dialysis.³¹⁵ The resulting calcium-free proteins have lost most of their catalytic activity (possibly 5–10% remains). Human saliva amylase requires 1 g-atom of calcium for full activity and the bacterial enzyme at least 4 g-atoms. It was suggested that, "By forming a tight metal chelate structure, the metal produces intramolecular cross-links similar in function to disulfide bridges, which confer to the α -amylase molecule the structural rigidity required for effective catalytic activity." It is of interest that the *B. subtilis* amylase which requires 4 g-atoms of calcium has no disulfide bridges. Taka-amylase A binds 10 g-atoms of calcium per mole. Nine of these can be removed by dialysis against 0.02 M sodium acetate without effect on the enzymatic activity, but the last is not removed after 6 days of dialysis against EDTA, and it has been claimed³¹⁵ that this cannot be removed without denaturation. According to other workers,^{316, 317a} however, incubation with EDTA causes inactivation, but the activity is recovered by the addition of calcium ion. Loss of this last calcium is accompanied by a sulfhydryl group becoming available. Presumably chelate formation between the sulfhydryl group and the calcium helps hold the enzyme in the active conformation.^{317b}

Halide ions also strongly enhance the catalytic efficiency of mammalian α -amylases, their effectiveness decreasing in the order $\text{Cl}^- > \text{Br}^- > \text{I}^-$ (see ref 298). Chloride ions also alter the pH- V_{max} profile. V_{max} for chloride-free hog pancreatic α -amylase depends on the ionization of two groups of $\text{p}K_a = 4.8$ and 6.0 – 6.4 , but in the presence of 0.25 M potassium chloride these are changed to 5.6 – 5.9 and 8.8 – 9.0 .²⁵⁷ The origin of these effects is not understood.

The most important β -amylases are those from wheat malt, soya bean, and sweet potato. They catalyze the hydrolysis of alternate α -1 \rightarrow 4 linkages of amylose starting from the non-reducing end to yield β -maltose. Apparently the molecular weight of only sweet potato β -amylase has been determined. This is reported to be 215,000,³¹⁸ the enzyme consisting of four subunits each with a molecular weight of approximately 50,000. An analysis of the binding sites of equilibrium dialysis experiments against cyclohexaamylose, an inhibitor, indicates that there is one binding site per subunit.³¹⁹

In addition to the amylases which only hydrolyze amylose to maltose, several enzymes are known which will hydrolyze it to glucose. These are called amyloglucosidases, glucamylases, or maltases. Probably the most widely studied of these are the amyloglucosidases from *A. niger*^{239, 320–324} and *Rh. dele-*

mar.^{253, 254, 325} Both enzymes catalyze the hydrolysis of α -1 \rightarrow 4 and α -1 \rightarrow 6 glucosidic linkages (relative rates of maltose and isomaltose *ca.* 30:1)^{322, 325} with inversion of configuration.^{251, 253, 254} It has been shown that the active site for the hydrolysis of 1 \rightarrow 4 and 1 \rightarrow 6 linkages is the same with the *Rh. delemar* enzyme.³²⁶

There has been much speculation on the nature of the catalytic groups of amylases (*cf.* ref 176) mainly based on the variation of the kinetic parameters with pH. Thus plots of $\log V_M$ against pH for pancreatic α -amylase were interpreted as indicating that the catalytic groups of the chloride-free enzyme had $\text{p}K_a$'s of 4.8 and 6.0–6.4 and of the chloride activated enzyme $\text{p}K_a$'s of 5.6–5.9 and 8.8–9.0.^{256, 257} Similar plots with β -amylase from sweet potato indicated $\text{p}K_a$'s of 3.75 and 7.0.³²⁷ The possibility that the more basic $\text{p}K_a$'s were associated with the ionization of a phenolic group of tyrosine was excluded by showing the absence of ionization of such a group spectrophotometrically and the intervention of phosphate was excluded by its absence. It appears that sulfhydryl groups^{327–330} and N-terminal amino groups³³¹ are not essential for catalytic action and the catalytic groups were therefore identified²⁵⁷ as carboxylate and imidazolium in agreement with the earlier proposal of Ono and his coworkers for "bacterial amyloclastic α -amylase."³³² It is of course formally possible that the kinetically equivalent un-ionized carboxyl and imidazole groups act as catalytic groups rather than their ionized forms. The concentration of enzyme with both groups un-ionized is proportional to the concentration of that with both ionized but very much less, and it was considered that it was probably too small to account for the observed rate.²⁵⁷

It was suggested^{256, 257, 274} that since the same catalytic groups appear to be implicated in catalysis by α - and β -amylases they operate by a common mechanism and that the different steric courses result from "specific guidance" of the water molecule to the reaction center by the enzyme (see also ref 238). The protonated imidazole group was visualized as acting as a general acid catalyst and the carboxylate group as stabilizing the developing glucosyl cation electrostatically through ion-pair formation.

The solvent isotope effect, $V_{\text{max}}(\text{H}_2\text{O})/V_{\text{max}}(\text{D}_2\text{O})$, is the same for both enzymes (1.25 at pH, pD 7.0) and argues against the carboxyl group acting as a general base catalyst with the β -amylase and as a nucleophilic catalyst with the α -amylase. It is of interest that this value is very similar to solvent isotope effect for the intramolecular general acid catalyzed hydrolysis of 2-carboxyphenyl β -D-glucoside ($k_{\text{H}_2\text{O}}/k_{\text{D}_2\text{O}} = 1.57$) (see section II.B).

It has also been suggested that carboxylate and imidazolium are catalytic groups of broad bean^{302, 303} and soya bean^{301, 309} α -amylases.

There has been much discussion of the difference in spe-

(315) E. A. Stein, J. Hsiu, and E. H. Fischer, *Biochemistry*, **3**, 56, 61 (1964).

(316) A. Tanaka, *Bull. Agr. Chem. Soc. Jap.*, **24**, 252 (1960).

(317) (a) T. Tagaki and T. Isemura, *J. Biochem. (Tokyo)*, **57**, 89 (1965); (b) M. Toda, I. Kato, and K. Narita, *ibid.*, **63**, 295, 302 (1968); H. Toda and K. Narita, *ibid.*, **63**, 302 (1968).

(318) M. Burr and D. Yphantis, results reported by J. A. Thoma, D. E. Koshland, J. Ruscica, and R. Baldwin, *Biochem. Biophys. Res. Commun.*, **12**, 184 (1963).

(319) J. A. Thoma, D. E. Koshland, J. Ruscica, and R. Baldwin, *ibid.*, **12**, 184 (1963).

(320) J. H. Pazur and T. Ando, *J. Biol. Chem.*, **234**, 1966 (1959).

(321) J. H. Pazur and T. Ando, *ibid.*, **235**, 297 (1960).

(322) J. H. Pazur and K. Kleppe, *ibid.*, **237**, 1002 (1962).

(323) S. A. Barker and J. G. Fleetwood, *J. Chem. Soc.*, 4857 (1957).

(324) S. A. Barker, E. J. Bourne, and J. G. Fleetwood, *ibid.*, 4865 (1957).

(325) J. H. Pazur and S. Okada, *Carbohydr. Res.*, **4**, 371 (1967).

(326) K. Hiromi, Z.-I. Hamazu, K. Takahashi, and S. Ono, *J. Biochem. (Tokyo)*, **59**, 411 (1966).

(327) J. A. Thoma and D. E. Koshland, *J. Mol. Biol.*, **2**, 169 (1960).

(328) M. L. Caldwell, C. E. Weil, and R. S. Weill, *J. Amer. Chem. Soc.*, **67**, 1079 (1945).

(329) J. E. Thoma, D. E. Koshland, R. Shinke, and J. Ruscica, *Biochemistry*, **4**, 714 (1965).

(330) M. Schramm, *ibid.*, **3**, 1231 (1964).

(331) R. L. McGeachin and J. H. Brown, *Arch. Biochem. Biophys.*, **110**, 303 (1965).

(332) S. Ono, K. Hiromi, and Y. Yoshikama, *Bull. Chem. Soc. Jap.*, **31**, 957 (1958).

cificity of α - and β -amylases, and the "induced fit theory" has been put forward to explain the fact that sweet potato β -amylase acts only on the nonreducing end of amylose but that the cyclohexamylose and cycloheptamylose are competitive inhibitors. In the induced-fit theory it is postulated that in the free enzyme the catalytic groups (A, B) (see Figure 3) are not aligned properly for catalysis and that this only occurs with a conformational change occurring when the reactive enzyme-substrate complex (ES) is formed. The substrate can also form an unreactive complex, ES', in which the same binding site is used but in which the catalytic groups are not aligned properly and a similar complex is considered to be formed by the cycloamyloses.³³³

V_{max} for the hydrolysis of maltose, panose, and isomaltose by the glucamylase of *Rh. delemar* depends on the ionization of two groups of $pK_a = 2.9$ and 5.9 .^{334, 335} The heats of ionization were calculated from the variation of the pK_a 's with temperature to be 0 and -0.5 kcal mole⁻¹, respectively, and these were considered to be characteristic of carboxyl groups (1.5 kcal mole⁻¹) rather than of imidazolyl groups (6.9–7.5 kcal mole⁻¹). Both groups were therefore considered to be carboxyl groups with the pK_a of one displaced, possibly as a result of it being close to the other which ionized first. This conclusion is of interest because it is similar to the conclusion from X-ray crystallographic studies concerning the catalytic groups of lysozyme (see section V.B), and it is tempting to speculate that their mechanisms of action are similar, although the glucamylase-catalyzed reactions proceed with inversion and the lysozyme-catalyzed ones with retention.

D. ALMOND EMULSIN β -GLUCOSIDASE^{336, 337}

There has been a large amount of kinetic work with this enzyme (mol wt 150,000),³³⁸ but in most of this only impure preparations have been used. It is rather unspecific as it catalyzes the hydrolysis of most β -D-glucosides, and also has some β -D-galactosidase, β -D-xylosidase, and α -L-arabinosidase activity.^{338–340} It has also (surprisingly) been reported to catalyze the hydrolysis of aryl β -D-glucopyranosides but 10 to 70 times less rapidly than those of the corresponding aryl β -D-glucopyranosides.^{341a}

The hydrolysis of methyl β -D-glucoside catalyzed by this enzyme has been shown to proceed with glucosyl-oxygen fission²⁴⁰ and those of helicin, salicin, and β -D-glucosyl fluoride proceed with retention of configuration.^{252, 259}

Nath and Rydon plotted the values of $\log k_2$ for the hydrolysis of a series of substituted phenyl β -D-glucosides against the σ constants¹²⁴ (see also ref 277). There appeared to be two separate lines for *meta*- and *para*-substituted compounds with slopes approximately 1.0 and 1.5, respectively. The values for

(333) J. A. Thoma and D. E. Koshland, *J. Amer. Chem. Soc.*, 82, 3329 (1960).

(334) K. Hiromi, K. Takahashi, Z.-I. Hamauzu, and S. Ono, *J. Biochem. (Tokyo)*, 59, 469 (1966).

(335) K. Hiromi, M. Kawai, and S. Ono, *ibid.*, 59, 476 (1966).

(336) S. Veibel, *Enzymes*, 1, 583 (1950).

(337) W. Pigman, "The Carbohydrates," Academic Press, New York, N. Y., 1957, p 562.

(338) F. J. Joubert and T. N. van der Walt, *J. S. Afr. Chem. Inst.*, 17, 79 (1964).

(339) R. Heyworth and P. G. Walker, *Biochem. J.*, 83, 331 (1962).

(340) M. V. Kelemen and W. J. Whelan, *Arch. Biochem. Biophys.*, 117, 423 (1966); D. J. Manners and J. P. Mitchell, *Biochem. J.*, 103, 43P (1967); D. J. Manners and D. C. Taylor, *Carbohydr. Res.*, 7, 497 (1968).

(341) (a) K. Yoshida, T. Kamada, N. Harada, and K. Kato, *Chem. Pharm. Bull. (Tokyo)*, 14, 583 (1966); (b) H. Sund and K. Weber, *Biochem. Z.*, 337, 24 (1963).

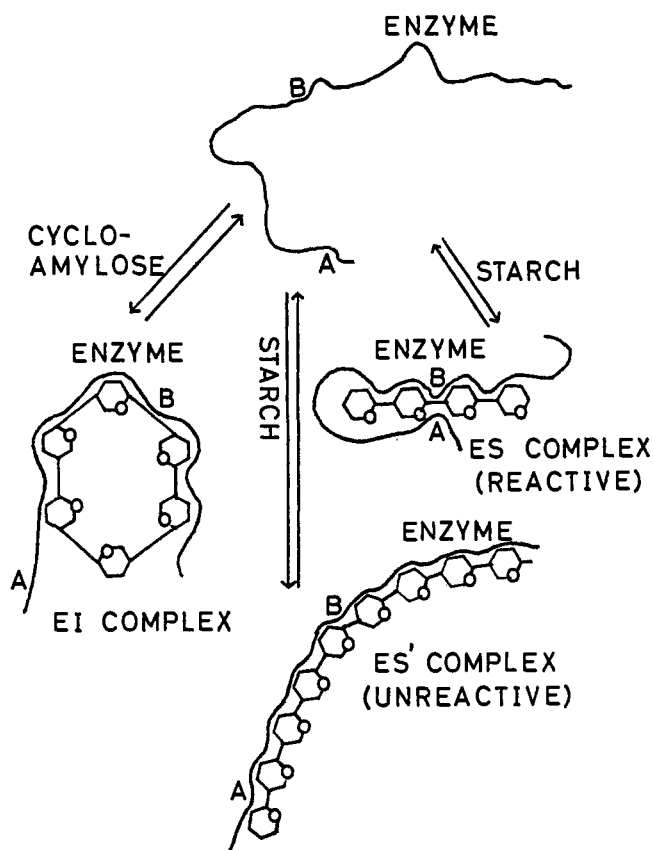

Figure 3. Schematic representation of the induced-fit theory.

the *p*-isopropyl and *p*-*t*-butyl glucosides fall well below the line for the other *para* isomers, and those for *ortho*-substituted phenyl glucosides are greater than those for the corresponding *para* isomers. This last effect is most marked with a methyl group with k_2 for *o*-tolyl β -D-glucoside 52.8 times that for *p*-tolyl β -D-glucoside. These effects are presumably connected with changes in the orientation of complexed substrate with respect to the catalytic groups of the enzyme.

E. β -GALACTOSIDASES^{173, 174}

The β -galactosidase of *E. coli* ML 309 (mol wt 518,000)^{341b} has been purified and investigated intensively by Wallenfels and his coworkers. Hydrolysis proceeds with galactosyl-oxygen fission and probably retention of configuration. The variation of V_{max} with pH indicated a dependence on the ionization of two groups of $pK_a = 6.67$ and 8.90 which were considered to be imidazole and sulfhydryl. It was suggested that the unprotonated imidazole group acts as a nucleophile and the thiol group as a general acid, the reaction involving a galactosyl enzyme intermediate. In the reviewer's opinion this is best written as shown in eq 21 with rearside attack, but this mechanism is of course highly speculative and there is no corroborating evidence for the intervention of a galactosyl enzyme. With the calf intestine β -galactosidase it was suggested that a carboxylate group acts as a nucleophile.

The hydrolysis of a series of aryl galactosides has not been investigated but V_{max} for the hydrolysis of *p*-nitrophenyl β -D-galactoside catalyzed by the enzyme from *E. coli* is about three times that for phenyl β -D-galactoside corresponding to a ρ value of about $+0.7$.

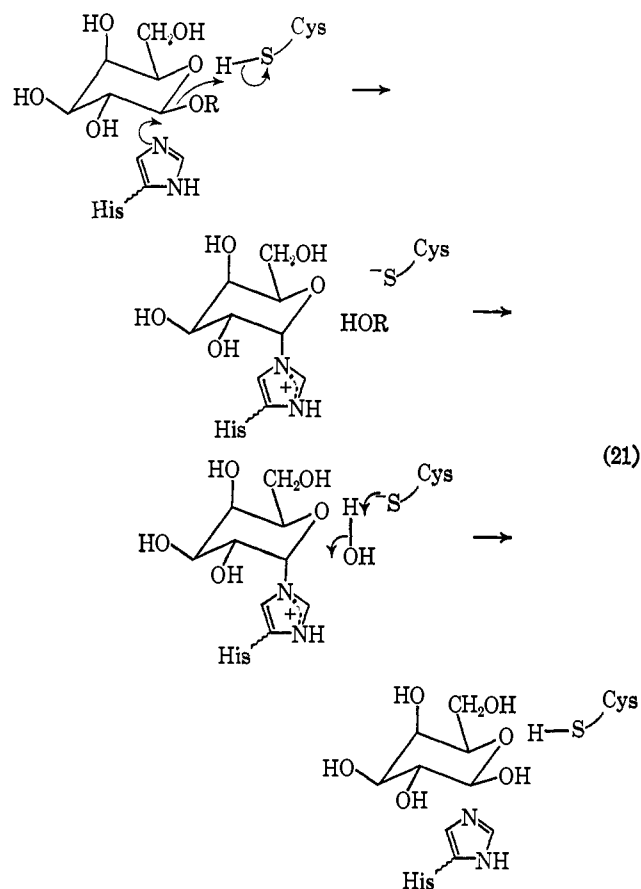

VI. Fischer Glycoside Synthesis

A. INITIAL REACTION

Aldoses or ketoses on treatment with alcohols containing hydrogen chloride, a sulfonic acid, or a strong acid ion-exchange resin yield glycosides. The major reactions which are thought to take place with an aldose usually are

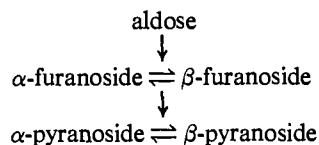

The mechanism of the initial reaction of the aldose to yield furanosides is not known although it is possible to make sensible speculations (see below). Levene, Raymond, and Dillon³⁴² showed that in methanol furanosides are generally formed first and pyranosides later and this was substantiated for D-xylose, D-ribose, D-glucose, D-galactose, and D-galacturonic acid methyl ester by following their reactions by gas, paper, or thin layer chromatography.^{100, 101, 103, 343} It appears, however, that with D-mannose,^{102, 342b} D-lyxose,¹⁰¹ and surprisingly L-arabinose,¹⁰² pyranosides are formed initially concurrently with the furanosides but at a slower rate (see Table XXXIII).

With xylose and glucose the thermodynamically less stable α -furanoside is formed more rapidly than the β -furanoside,^{101, 343} but with ribose the more stable β -furanoside is

Table XXXIII

Relative Rates of Formation of Glycosides in the Presence of Dowex-50 Ion-Exchange Resin at 65°¹⁰²

	Furanosides		Pyranosides	
	α -	β -	α -	β -
D-Mannose	20	11	4	1
L-Arabinose	9	13	1	1

formed more rapidly than the α -furanoside,¹⁰¹ and the initially formed furanoside mixture contains a higher proportion of the former than the pseudo-equilibrium mixture of ribofuranosides does. The factors which control the proportions of α and β anomers formed in these reactions are not understood.

In the reviewer's opinion, the highly speculative mechanism shown in Scheme II for D-glucose is the most reasonable. It involves capture by methanol of the aldehydo intermediate in the anomerization of the pyranose forms which presumably is occurring rapidly under the acidic conditions. This process is analogous to the capture of this same intermediate by water, which it is necessary to postulate to occur in aqueous solution to explain the oxygen exchange (see section X.A). It yields two diastereoisomeric hemiacetals which may either revert to the aldehydo form or undergo ring closure. This latter reaction is similar to the ring closure of glucose dimethyl acetal (see section VII) which is known to yield furanosides predominantly and is probably a concerted process.^{343, 344}

It is of considerable interest that it has recently been shown that with xylose³⁴³ and arabinose³⁴⁴ the dimethyl acetals are also present in the initial stages of the glycosidation reactions. These are not formed directly, however, but from the xylofuranosides and arabinosides (ring size unspecified) which are the earliest identifiable products.^{343, 344}

B. ANOMERIZATION OF FURANOSIDES

The second step in the Fischer synthesis is the conversion of the initially formed mixture of furanosides into the pseudo-equilibrium mixture (see Table XXXIV). This anomerization

Table XXXIV

Rate Constants for the Anomerization of Methyl Furanosides in

Methanol ($\alpha \xrightleftharpoons[k_{-1}]{k_1} \beta$) (sec⁻¹)^{99, 101, 342b, 345}

Furanosides of	$10^3 k_1$	$10^3 k_{-1}$
0.01% HCl at 35°		
D-Xylose	49	29
D-Arabinose	1.39	4.35
D-Lyxose	Very small	Very large
D-Ribose	11.3	3.4
0.10 M MeSO ₃ H at 35.2°		
D-Glucose	4.34	2.55

has been studied independently to yield the rate constants given in Table XXXIV.

(342) (a) P. A. Levene, A. L. Raymond, and R. T. Dillon, *J. Biol. Chem.*, **95**, 699 (1932); (b) V. Smirnyagin and C. T. Bishop, *Can. J. Chem.*, **46**, 3085 (1968).

(343) R. J. Ferrier and L. Hatton, *Carbohydr. Res.*, **6**, 75 (1968).

(344) D. D. Heard and R. Barker, 153rd National Meeting of the American Chemical Society, Miami Beach, Fla., April 1967, No. C-18; *J. Org. Chem.*, **33**, 740 (1968).

(345) G. W. Loveday, unpublished observations.

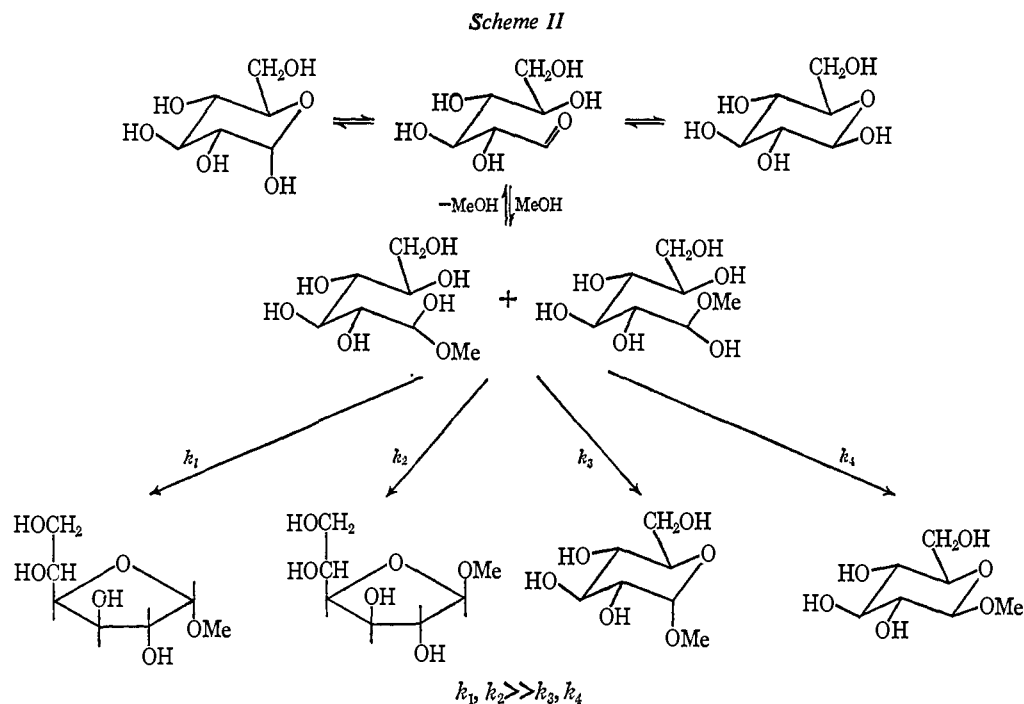

Tracer experiments with methyl β -D-glucopyranoside in ^{14}C -labeled methanol showed that the anomerization was accompanied by incorporation of the label,⁹⁹ and when the reaction was carried out in CD_3OD no α -furanoside with a proton-containing methoxyl group could be detected by nmr spectroscopy.^{3,46} The main reaction pathway must therefore involve exchange of the methoxyl group with solvent. The entropy of activation is $-14.9 \pm 1.0 \text{ eu}$ ^{3,45} and the most likely mechanisms^{3,46} involve a bimolecular displacement of methanol (eq 22) or a concerted ring opening to yield D-glucose dimethyl acetal which is known to undergo ring closure to furanosides (eq 23).

The formation of the acetal in a concerted process rather than a stepwise one involving a carbonium ion would be expected from the principle of microscopic reversibility and the fact that the ring closure of the acetal to yield furanosides is concerted.^{188,189} The recent demonstration^{2,43} that xylose dimethyl acetal is formed from the xylofuranosides in acidic methanol and is present in the pseudo-equilibrium mixture clearly indicates that the mechanism of eq 23 is followed, at least in part, but whether that of eq 22 is followed as well and whether these conclusions can be generalized to the furanosides of other aldoses remains to be decided.

C. RING EXPANSION OF FURANOSIDES TO PYRANOSIDES

In methanol the anomerizations of all the furanosides so far studied are much faster than the subsequent ring expansions to pyranosides (see Tables XXXIV and XXXV), thus making it impossible to measure the individual rate constants for the ring expansion of each anomer. For this reason also it is not possible to determine the steric course of the ring expansion although the composition of the ring-expanded mixture of pyranosides is known (Table XXXVI).

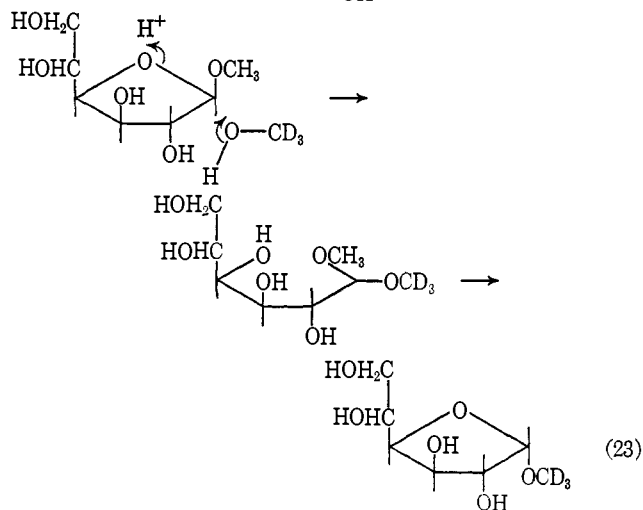
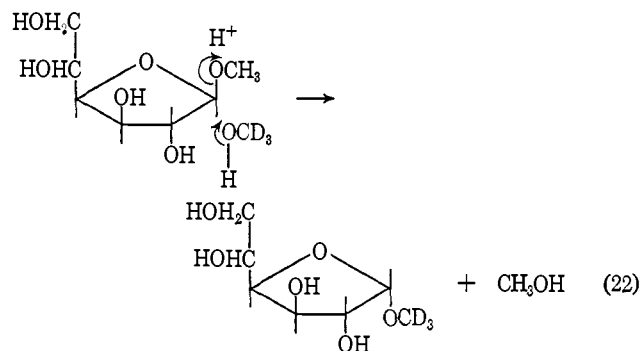

The most likely mechanisms are given for methyl α -D-glucopyranoside in eq 24–26. That of eq 24 is not favored since it involves what would probably be a fairly high-energy bicyclic intermediate and with the glucosides preferred formation of the β -pyranoside might be expected owing to shielding by the departing oxygen in the product-forming step (step 2), whereas the α -glucoside is the major product. It also seems unlikely that the lyxofuranosides would be the fastest reacting

Table XXXV

Rate Constants for the Ring Expansion of Furanosides (k_1) and Ring Contraction of Pyranosides (k_{-1}) in Methanol (sec^{-1})^{99,101,342b}

Aldose	$10^4 k_1$	$10^4 k_{-1}$
0.1% HCl at 35°		
D-Xylose	1.2	0.004
D-Arabinose	0.88	0.11
D-Lyxose	8.4	0.011
D-Ribose	0.69	0.08
2.00 M MeSO ₃ H at 35°		
D-Glucose	$10^4 k_1$ 2.88	

Table XXXVI

Approximate Composition of Ring-Expanded Mixture of Methyl Aldofuranosides in Methanol^{99,101,103,342b}

	% α	% β
0.1% HCl at 35°		
Xylopyranosides	33	66
Ribopyranosides	20	80
Lyxopyranosides	80	20
Arabinopyranosides	50	50
Methyl galacturonosides ^a	~ 80	~ 20
2 M MeSO ₃ H at 35°		
Glucopyranosides	73	27

^a 2% methanol at reflux.

pentofuranosides (see Table XXXV) if this were the mechanism since the bicyclic intermediate would be here the least favored as it has both the hydroxyl groups *endo* (see 92).



Again the fact that the ring closure of glucose dimethyl acetal to furanosides is a concerted process^{188,189} argues for the ring opening being concerted also (eq 26) with acetal 94 rather than carbonium ion 93 being the intermediate. It seems possible then that the acetal is an intermediate in both the anomerization and ring expansion of furanosides, and that the higher rate of the former reaction is the result of its ring closure to yield a five-membered ring being faster than that to yield a six-membered ring, which is the normal behavior in ring-closure reactions of a fully saturated chain involving an oxygen nucleophile (see ref 187).

The slowness of the ring-closure reactions of aldose acetals to pyranosides means that they cannot be proceeding much faster than the unassisted rate of ionization, and hence, unlike the ring closure to furanosides, they are probably not concerted but involve an intermediate carbonium ion.

The fact that some pyranosides undergo a ring contraction to furanosides is of considerable interest since this must proceed by the reverse of the mechanism of the ring expansion of furanosides and involve an acyclic intermediate(s). If then the anomerization of all pyranosides like that of the glucopyranosides do not involve ring opening^{346,347a} a comparison

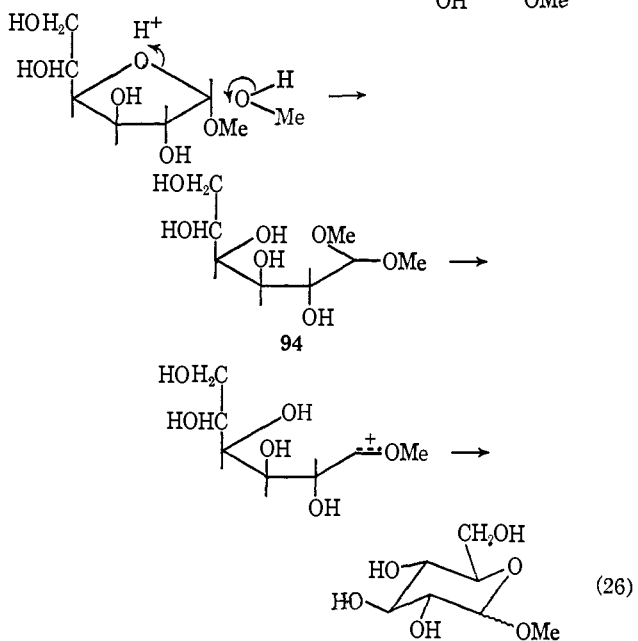
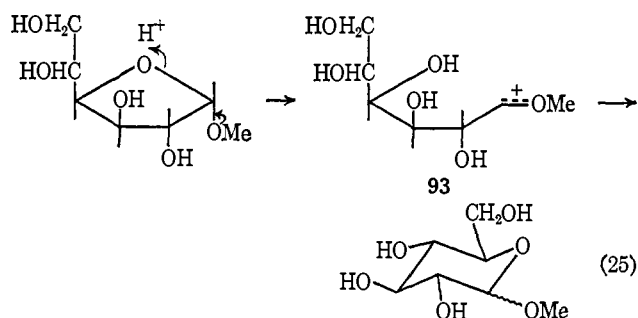
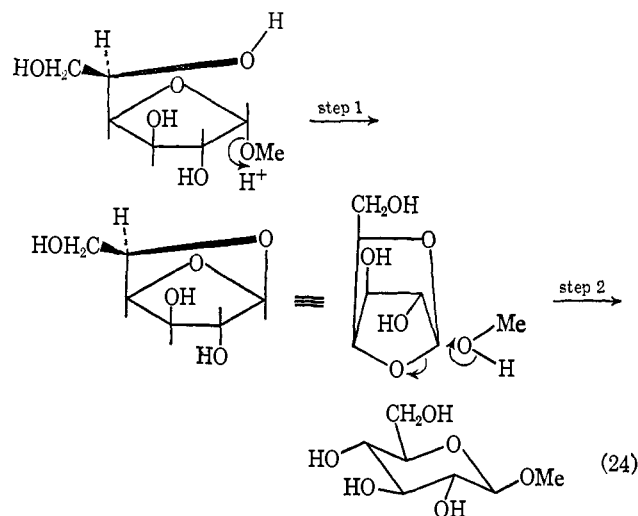

(347) (a) B. Capon, *Chem. Commun.*, 21 (1967), (b) It has been reported that when methyl β -D-glucopyranoside is heated in methanolic hydrogen chloride, it is partly converted into methyl β -D-glucopyranoside but that methyl α -D-glucopyranoside is unchanged under the same conditions. However, when the reactions are conducted in ¹⁴C-labeled methanol, incorporation of the label into both pyranosides was reported to occur: A. Temeriusz, *Rocz. Chem.*, 40, 825 (1966); J. Sniderski and A. Temeriusz, *Carbohydr. Res.*, 3, 225 (1966). These results are inconsistent with those reported in ref 346 and 347a. It is difficult to judge their validity because the system used, refluxing methanolic hydrogen chloride, is one in which acid is rapidly lost through conversion to methyl chloride, and hence the conditions are not well characterized. The methods used to detect if the pyranosides had reacted were nonquantitative recovery through recrystallization and paper chromatography. The R_f values of the methyl α - and β -glucopyranosides were reported to be 0.34 and 0.36, respectively.

of the rate of ring contraction and anomerization for a pyranoside measures the relative ease by which it undergoes methanolysis *via* an acyclic and a cyclic pathway. This information is relevant to the mechanism of hydrolysis of glycopyranosides for which similar pathways have been considered (see section II.A.1). A comparison of the results in Tables XXXV and XXXVII shows that the relative rates of ring contraction to anomerization are approximately as follows: D-glucopyranosides, very small; D-xylopyranosides, 1–3%; D-arabinopyranosides, 4–12%; D-lyxopyranosides, 1–2%; D-ribose, 7–40%. If this argument is valid then, it might be expected that of these pyranosides the most likely one to undergo hydrolysis with ring opening would be the β -D-ribose.

D. ANOMERIZATION OF PYRANOSIDES

The final step in the Fischer synthesis is the equilibration of the kinetically controlled mixture of pyranosides. This anomerization has been studied kinetically for several aldoses to yield the rate constants given in Table XXXVII. The most

Table XXXVII

Rate Constants for the Anomerization of Methyl Pyranosides in Methanol ($\alpha \xrightleftharpoons[k_{-1}]{k_1} \beta$) (sec⁻¹)^a

Pyranosides of	$10^4 k_1$	$10^4 k_{-1}$
	1% HCl at 35°	
D-Xylose	1.4	3.1
D-Arabinose	18	9.3
D-Lyxose	7.2	62
D-Ribose	11	2
	2.00 M MeSO ₃ H at 35°	
D-Glucose	2.9	7.8

^a See also ref 342b.

thoroughly studied is that of the glucopyranosides which have entropies of activation of $+5.7 \pm 1.0$ (α) and $+7.7 \pm 1.0$ eu (β) at 35°. ³⁴⁵ Reasonable mechanisms involve a cyclic ion (eq 27), an acyclic ion (eq 28), and the glucose acetal (eq 29) as intermediates. That involving the acyclic ion and a mechanism involving the nonstereospecific formation of the acetal were excluded by tracer experiments in CD₃OD which showed that the anomerization was accompanied by complete (>98%) exchange of the methoxyl group with the solvent. ^{346, 347b} A mechanism involving stereospecific formation and ring closure of the acetal, which would result in the anomerization proceeding with complete exchange of the methoxyl group, was also excluded by showing that under the reaction conditions the acetal yielded not pyranosides but furanosides which only underwent ring expansion slowly. This leaves the mechanism of eq 27 as the most likely one. Whether it is to be regarded as being of the limiting A1 type or as possessing some A2 character as has been proposed by Bunnett, ¹²¹ for the analogous mechanism for glycoside hydrolysis is uncertain, but clearly the latter possibility should be borne in mind, especially as the entropies of activation for the anomerization are less strongly positive than for the hydrolysis. The steric course of the methanol exchange is predominantly inversion of configuration (>80%), but the accuracy of the nmr method used did not permit its being determined more accurately than this. If the reaction does involve a carbonium ion, this must therefore be captured predominantly on the side opposite to the

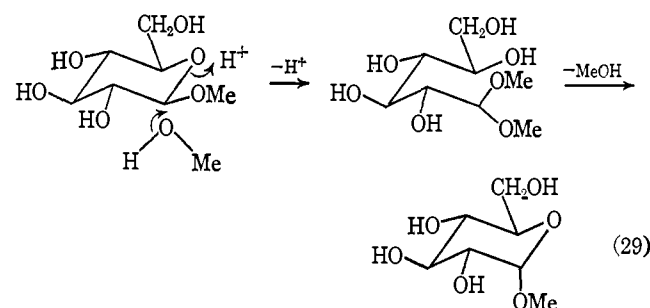
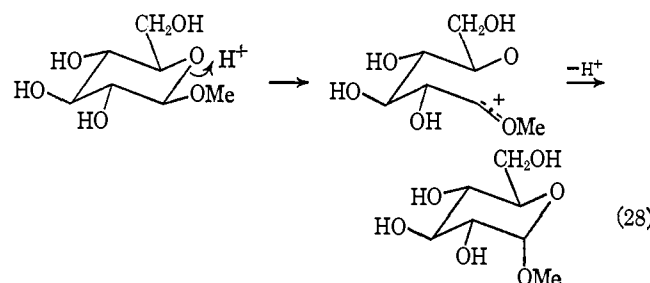
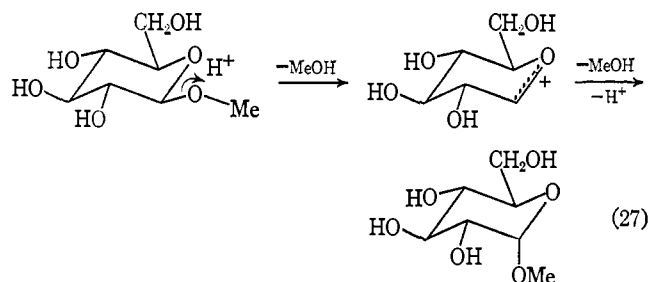

departing methoxyl group in a way similar to that proposed for the methanolysis of the phenyl glucosides and tetra-O-methyl- α -D-glucopyranosyl chloride. ^{123, 348a}

It has recently been shown by experiments with ¹⁴C-labeled compounds that anomerization of the ethyl xylosides occurs with exchange of ethoxyl groups, and that this proceeds with approximately 80 and 60% inversion of configuration with the α - and β -xylosides, respectively. These reactions must therefore be unimolecular. ^{348b}

E. CONCLUSION

The reactions outlined in Scheme III thus seem to the reviewer to be the most likely ones to be occurring in the Fischer synthesis of glucosides. In parts, this scheme is highly speculative, but it is a reasonable working hypothesis upon which to base further experiments. It may possibly require modification to accommodate a small amount of ring contraction of the pyranosides, and it will definitely require this if extended to other sugars which are known to undergo this reaction.

VII. Ring-Closure Reactions of Aldose Acetals

In water or methanol containing acid, aldose acetals undergo ring-closure reactions to yield glycofuranosides. In water there is also concurrent hydrolysis to the free aldose as shown in Table XXXVIII. ^{138, 139}

The ring closure could either be concerted with the rupture of the acetal bond (eq 30) or occur subsequently, with a carbonium ion intermediate which is competed for by water

(348) (a) A. J. Rhind-Tutt and C. A. Vernon, *J. Chem. Soc.*, 4637 (1960); (b) R. Ferrier and L. Hatton, *Carbohydr. Res.*, 8, 56 (1968).

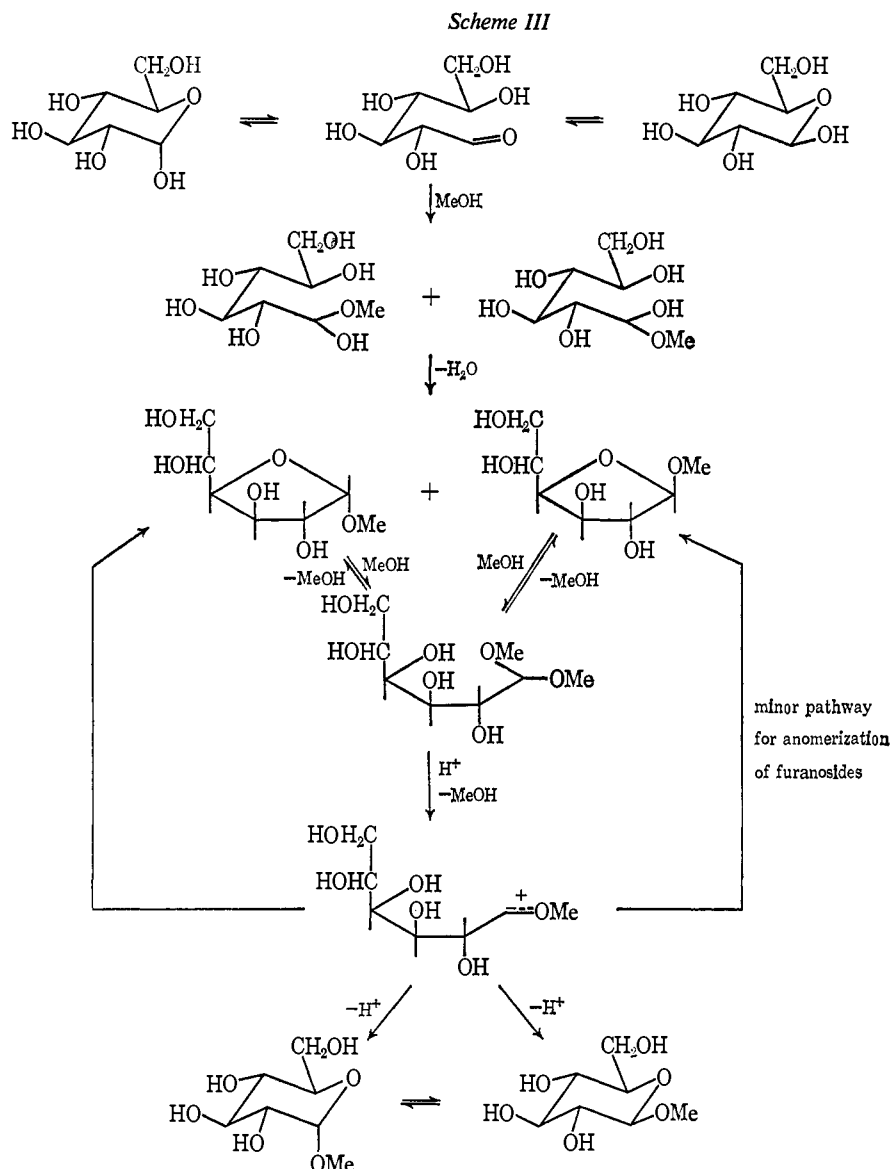

Table XXXVIII

Kinetically Controlled Products and Rate Constants for the Reactions of Some Acyclic Aldose Acetals in 0.05 M HCl at 35°

Dimethyl acetal of	Products, %			$10^4 k_{\text{total}}$, sec^{-1}
	Aldose	Furan- oside	Pyran- osides	
D-Glucose	~1.5	~98.5	<0.5	17
D-Galactose	18	82	<0.5	1.58
L-Arabinose	18	82	<0.5	1.66

Table XXXIX

The Cyclization of Acetals (0.03–0.05 M) in Methanol Containing Methanesulfonic Acid (0.001 M) at 34.92°

	$10^4 k$, sec^{-1}	Furanoside	
		α - $\pm 5\%$	β - $\pm 5\%$
D-Glucose dimethyl acetal	16	73	27
D-Galactose dimethyl acetal	2.8	68	32
L-Arabinose dimethyl acetal	2.8	30	70

and internal hydroxyl group (eq 31). With the latter mechanism the total rate of reaction is the rate of ionization (step 1), and it would be surprising if this depended on the configuration of carbon 4, but with the former the rate of ring closure and hence the total rate is much more likely to depend on this configuration. The observation that k_{total} for the glucose acetal is about ten times greater than for the galactose acetal and that the product from the glucose acetal contains a much higher proportion of furanosides therefore supports the mechanism of eq 30.

The anchimeric assistance provided by the hydroxyl group of the glucose and galactose acetal corresponds to rate enhancements of 340- and 29-fold, respectively, as compared to the unassisted rate calculated by the Taft $\rho^*\sigma^*$ relationship.

The glucose acetal also undergoes ring closure about six times faster than the galactose acetal in methanolic solution (Table XXXIX), suggesting that this is also a concerted process. The possibility that this difference resulted from there being a reversible dissociation to a carbonium ion and methanol which partitioned more favorably to furanosides with

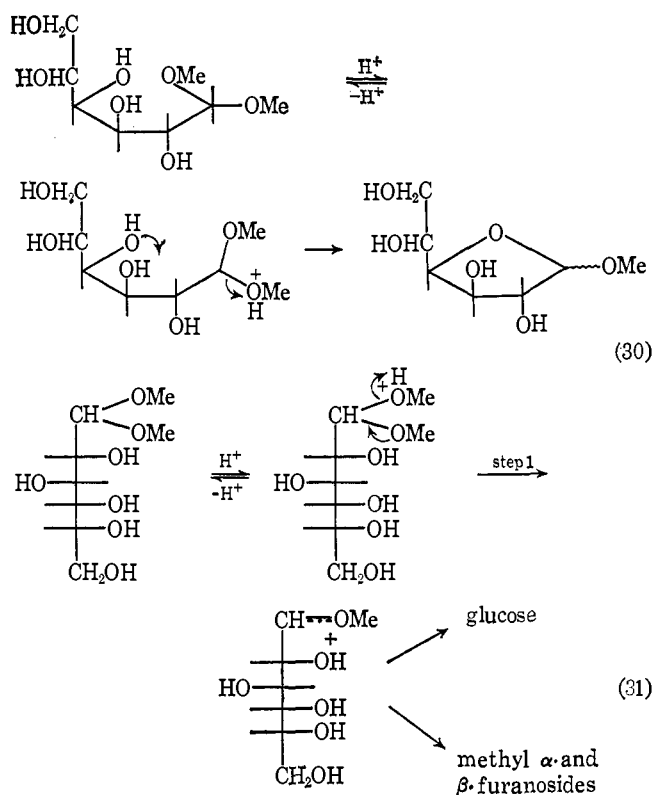

the glucose than with the galactose acetal was excluded by showing that the latter did not undergo appreciable exchange of methoxyl when CD_3OD was used as solvent.¹⁸⁹

It is interesting but difficult to explain that in these ring closures and in the ones in aqueous solution the predominant furanosides are the thermodynamically less stable ones with the hydroxyl at C(2) and methoxyl at C(1) *cis* to one another.

VIII. Formation, Rearrangement, and Hydrolysis of Cyclic Acetals and Ketals³⁴⁹

A. FORMATION AND REARRANGEMENT

Although the stereochemistry and relative stabilities of cyclic acetals have received considerable attention,³⁵⁰⁻³⁵⁴ there has been no systematic study of the mechanism of their formation. Several illuminating investigations of isolated examples have been reported, however, mainly by Foster and his coworkers.

It is frequently found that the most rapidly formed product of the reaction of a polyol with an aldehyde or ketone is not the thermodynamically most stable, and so the initially formed products often rearrange to more stable isomers. Thus, by following the change in nmr spectrum, it was shown that the reaction of glycerol with benzaldehyde in dimethylformamide in the presence of toluene-*p*-sulfonic acid yields first *cis*- and *trans*-dioxolanes **95** and **96**, with the former in slight excess, and that these are slowly converted into an equilibrium mixture in which the dioxanes **97** and **98** predominate.³⁵⁵ It follows

that, if it is the primary alcohol group of glycerol which is used in hemiacetal formation, the intermediate ion (**99**) undergoes ring closure preferentially to form a five- rather than a six-membered ring. The reaction of glycerol with acetaldehyde proceeds similarly to yield dioxolanes first and dioxanes later.^{356, 357}

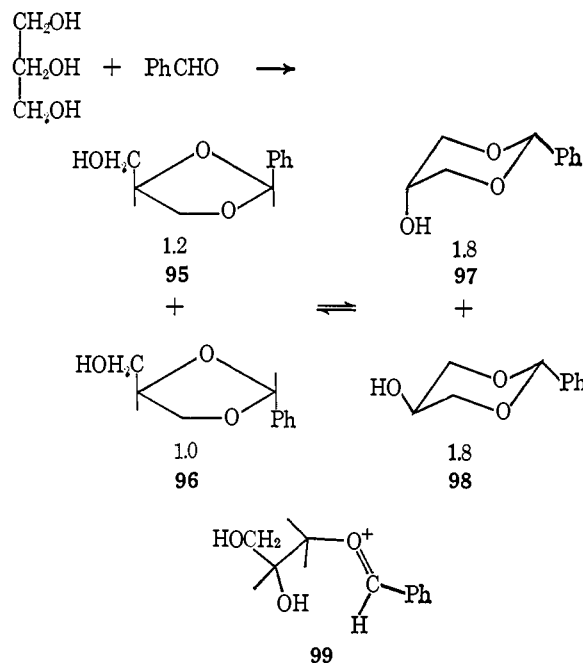

Figures are proportions at equilibrium.

Slightly more complex behavior is found in the reaction of glucitol with *n*-butyraldehyde in 1 *M* aqueous sulfuric or hydrochloric acid which apparently yields the 2,3 acetal first and only later the more stable 2,4 and 3,4 acetals³⁵⁸ (see also ref 359).

The reaction of 1,4-anhydroerythritol with benzaldehyde in nitromethane containing toluene-*p*-sulfonic acid has also been investigated by following the change in nmr spectrum.³⁶⁰ Acetal **100** with the phenyl group *endo* is formed first, and this then equilibrates with its isomer **101** with the phenyl group *exo*. It was suggested that the preferred conformation of the protonated form of the hemiacetal was **102** and that this lost water to form a transoid carbonium ion **103** which was

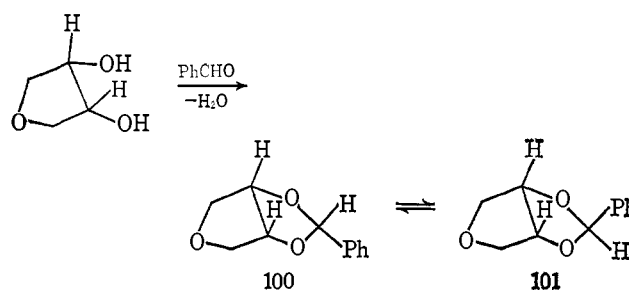

(349) A. N. de Belder, *Advan. Carbohydr. Chem.*, 20, 219 (1965).

(350) S. A. Barker and E. J. Bourne, *ibid.*, 7, 137 (1952).

(351) J. A. Mills, *ibid.*, 10, 1 (1955).

(352) R. U. Lemieux in ref 36a, Part 2, p 723.

(353) N. Baggett, K. W. Buck, A. B. Foster, and J. M. Webber, *J. Chem. Soc.*, 3401 (1965).

(354) A. B. Foster, M. H. Randall, and J. M. Webber, *ibid.*, 3388 (1965).

(355) N. Baggett, J. M. Buxbury, A. B. Foster, and J. M. Webber, *Carbohydr. Res.*, 2, 216 (1966).

(356) G. Asknes, P. Albriktsen, and P. Juvvik, *Acta Chem. Scand.*, 19, 920 (1965).

(357) G. Asknes and P. Albriktsen, *ibid.*, 20, 1330 (1966).

(358) T. G. Bonner, E. J. Bourne, P. J. V. Cleave, and D. Lewis, *Chem. Ind. (London)*, 1268 (1966); *J. Chem. Soc., C*, 822, 827 (1968).

(359) B. Capon, M. J. Perkins, and C. W. Rees, "Organic Reaction Mechanism 1966," John Wiley and Sons, Ltd., London, 1967, p 309.

(360) F. S. Al-Jeboury, N. Baggett, A. B. Foster, and J. M. Webber, *Chem. Commun.*, 222 (1965).

attacked most rapidly from the top by the hydroxyl group to yield acetal **100** with the phenyl group *endo*.³⁶⁰

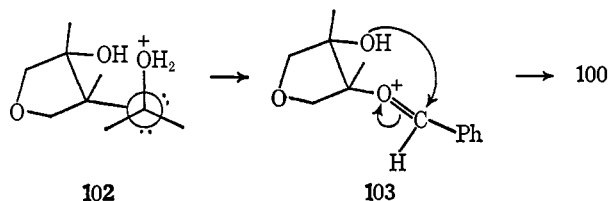

A similar explanation has been put forward to explain the observation that 2,4-benzylidene-D-erythrose, on treatment with toluene-*p*-sulfonic acid in dimethylformamide, yields 2,3-*O*-benzylidene-D-erythro-furanose with the phenyl group *endo* (**106**). This is presumably formed through the *cis* aldehyde (**105**), and it was suggested that the reaction proceeds *via* the *trans*-oxonium ion (**104**) which is attacked preferentially from the top by O(2).³⁶¹

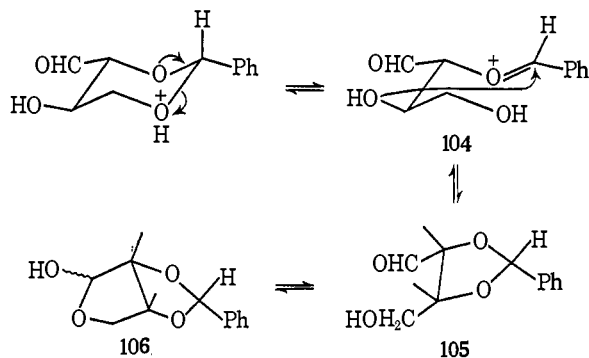

An investigation of the reaction of sorbose and acetone has been reported.^{362, 363}

B. HYDROLYSIS

Acetals and ketals derived from sugars follow the general pattern that acetals are usually hydrolyzed more slowly than the corresponding ketals (see, however, ref 364) and that acetals derived from formaldehyde are hydrolyzed more slowly than those derived from other aldehydes (see ref 365).

The most striking effect of the sugar moiety on the rate is that ketals formed from the hydroxyl group at C(1) of an aldose are hydrolyzed more slowly than those derived from the other hydroxyl groups. The best example of this behavior is the selective removal of the 5,6-isopropylidene group of a 1,2:5,6-diisopropylidenealdose by acid hydrolysis,³⁶⁵ and it has been shown by Collins that the rate of hydrolysis of 1,2:5,6-diisopropylidene-glucose to 1,2-isopropylidene-glucose is about 80 times faster than that of the latter to glucose.³⁶⁶

It seems highly probable that 1,2-isopropylidene-glucose is hydrolyzed with ketone-oxygen fission since its acid-catalyzed methanolysis yields glucose, not methyl glucopyranosides as would be expected if there were glucosyl-oxygen fission.³⁶⁶ Two pathways involving ketone-oxygen fission are possible,

as shown in eq 32, but at present it is not possible to decide which or if both are being followed.

The slow rate of hydrolysis of 1,2-isopropylidene-glucose could result either from a steric effect arising from the fact that the 1,3-dioxolane ring is fused to a tetrahydrofuran ring or from an electronic effect of the ring oxygen. Evidence that the former is important comes from the observation that the isopropylidene derivative of *cis*-cyclopentane-1,2-diol is hydrolyzed 25 to 30 times more slowly than the isopropylidene derivatives of racemic and *meso*-butane-2,3-diol.³⁶⁷ It is also significant that 2,3:5,6-diisopropylidene-mannose is hydrolyzed to 2,3-isopropylidene-mannose.³⁶⁸ An important factor in causing the hydrolysis of a 1,3-dioxolane ring fused to another five-membered ring to be slower than when it is not fused could be that the release of eclipsing strain in the transition state is less.

It is also possible that the ring oxygen causes a rate decrease. With mechanism b of eq 32, its electron-withdrawing inductive effect should decrease the rate by reducing the standing concentration of conjugate acid, and if this effect were larger than the rate increasing effect on the heterolysis step (see **107**) an over-all rate decrease would result. With mecha-

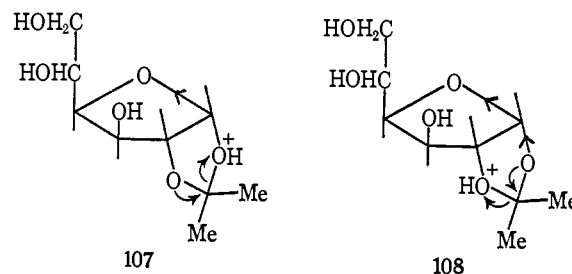

nism a its effect on the standing concentration of conjugate acid would be smaller (but still rate decreasing) as it is one carbon atom more remote from the site of protonation, but the effect on the rate of heterolysis would also be rate decreasing (see **108**).

Collins also showed that inverting the configuration of C(3) of 1,2-isopropylidene-glucose to give the *allo* compound resulted in a threefold increase in the rate of hydrolysis and that removing the hydroxyl at C(3) to give the 3-deoxy compound resulted in a sixfold increase.³⁶⁶

A number of semiquantitative measurements have been made on the hydrolysis of isopropylidene derivatives of alditols. Thus the terminal isopropylidene groups of 1,2:3,4:5,6-tri-*O*-isopropylidene-D-mannitol³⁶⁹ and of 1,2:3,4-di-*O*-isopropylidene-L-rhamnitol³⁷⁰ are hydrolyzed preferentially to yield the 3,4-isopropylidene derivatives. 1,3-Isopropylidene-glycerol is hydrolyzed about seven times faster than 1,2-isopropylidene-glycerol.^{369, 371a} The interesting observation has recently been made that the hydrolysis of 1,6-anhydro-2,3-*O*-isopropylidene β -D-talopyranose proceeds at least in part *via* the 3,4-isopropylidene derivative.^{371b}

The only other class of acetals or ketals derived from sugars whose hydrolysis has been investigated at all extensively are the 4,6-benzylidene derivatives of methyl aldopyrano-

(361) N. Baggett, K. W. Buck, A. B. Foster, B. H. Rees, and J. M. Webber, *J. Chem. Soc., C*, 212 (1966).

(362) K. Tokuyama, E. Honda, and N. Hoki, *J. Org. Chem.*, **29**, 133 (1964).

(363) T. Maeda, M. Kiyokawa, and K. Tokuyama, *Bull. Chem. Soc. Jap.*, **38**, 332 (1965).

(364) T. H. Fife and L. Hagopian, *J. Org. Chem.*, **31**, 1772 (1966); T. H. Fife and L. H. Brod, *ibid.*, **33**, 4136 (1968).

(365) A. N. de Belder, *Advan. Carbohydr. Chem.*, **20**, 235 (1965).

(366) P. M. Collins, *Tetrahedron*, **21**, 1809 (1965).

(367) F. Fischer and R. Schiene, *J. Prakt. Chem.*, **22**, 39 (1963).

(368) K. Freudenberg, W. Dürr, and H. von Hochstetter, *Ber.*, **61**, 1735 (1928).

(369) N. Baggett, K. W. Buck, A. B. Foster, R. Jefferis, B. H. Rees, and J. M. Webber, *J. Chem. Soc.*, 3382 (1965).

(370) M. A. Bukhari, A. B. Foster, J. Lehmann, and J. M. Webber, *ibid.*, 2287 (1963).

(371) (a) J. S. Brimacombe, A. B. Foster, and L. C. N. Tucker, *Carbohydr. Res.*, **3**, 76 (1966); (b) N. A. Hughes, *ibid.*, **7**, 474 (1968).

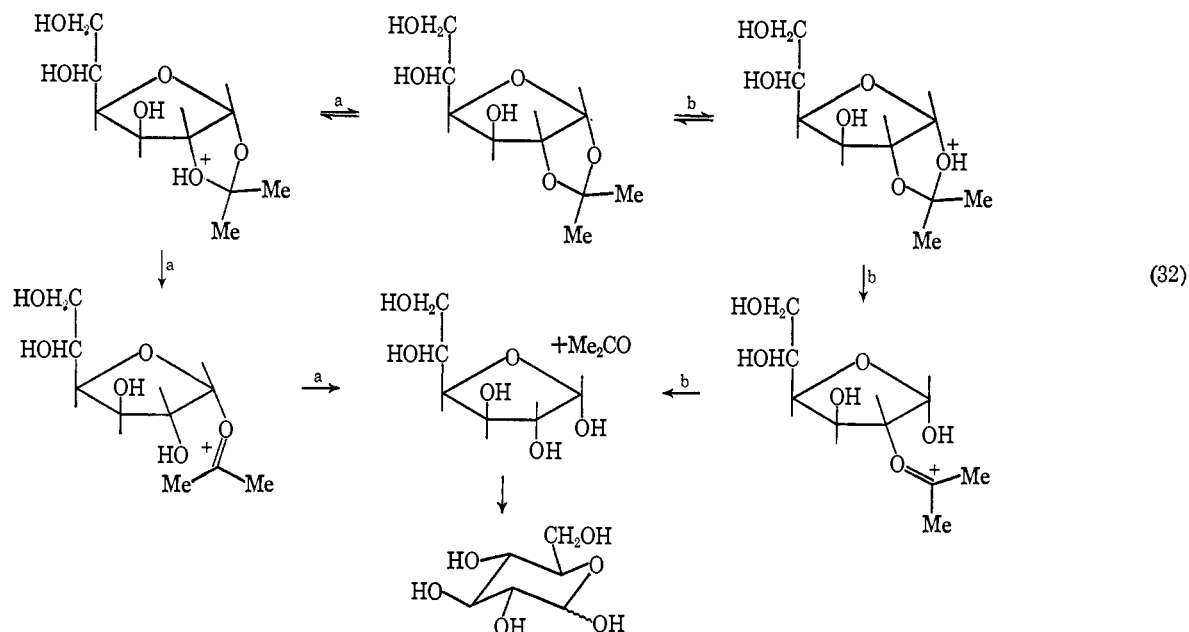

sides.³⁷²⁻³⁷⁴ These have a 1,3-dioxane ring fused to a pyranose ring and with hexosides of the *gluco*, *manno*, *altro*, and *allo* configurations the ring fusion is *trans*, but with those of the *galacto*, *talo*, *gulo*, and *ido* configurations it is *cis*. The effect of variation of the configuration of the sugar on the rate of hydrolysis is slight, but with all the compounds so far investigated (see Table XL and ref 373) those with a *trans*-ring

Table XL

First-Order Rate Constants for the Hydrolysis of Methyl 4,6-O-Benzylidenehexosides^a

4,6-O-Benzylidene derivative of	Ring fusion	10 ³ k, sec ⁻¹	Rel rate
Methyl α-D-glucoside (109)	<i>trans</i>	15.7	2.7
Methyl β-D-glucoside	<i>trans</i>	8.97	1.5
Methyl α-D-mannoside (110)	<i>trans</i>	20.6	3.5
Methyl α-D-altroside (111)	<i>trans</i>	16.9	2.9
Methyl α-D-galactoside (112)	<i>cis</i>	6.10	1.0
Methyl β-D-galactoside	<i>cis</i>	7.34	1.2
Methyl α-D-idoside (113)	<i>cis</i>	5.92	1.0
Methyl 3-deoxy-α-D-glucoside	<i>trans</i>	17.4	2.9
Methyl 2,3-di-O-methyl-α-D-glucoside	<i>trans</i>	6.49	1.1

^a At 40.0 ± 0.1° in 96% ethanol 0.03 M in hydrogen chloride.³⁷³

junction are hydrolyzed more rapidly than analogous ones with a *cis* junction.

The rate-determining step could involve fission of the bond between the benzaldehyde carbon and either O(6) or O(4) of the sugar, but at present it is not known which.

Replacement of the hydroxyl group at C(2) or C(3) of methyl 4,6-benzylidene-α-D-altroside (111) by an amino group causes a decrease in the rate of hydrolysis (see Table XLI).

Table XLI

First-Order Rate Constants for the Hydrolysis of Methyl 4,6-Benzylidene-α-D-altrosides^a

Methyl 4,6-benzylidene-α-D-altroside	10 ³ k, sec ⁻¹
Unsubstituted	117
2-Amino-2-deoxy	66
3-Amino-3-deoxy	16.1
3-Deoxy-3-methylamino	9.52
3-Deoxy-3-dimethylamino	4.03

^a At 43° in a mixture of ethanol and glycine buffer, pH 1.95 (1:1 v/v).³⁷⁴

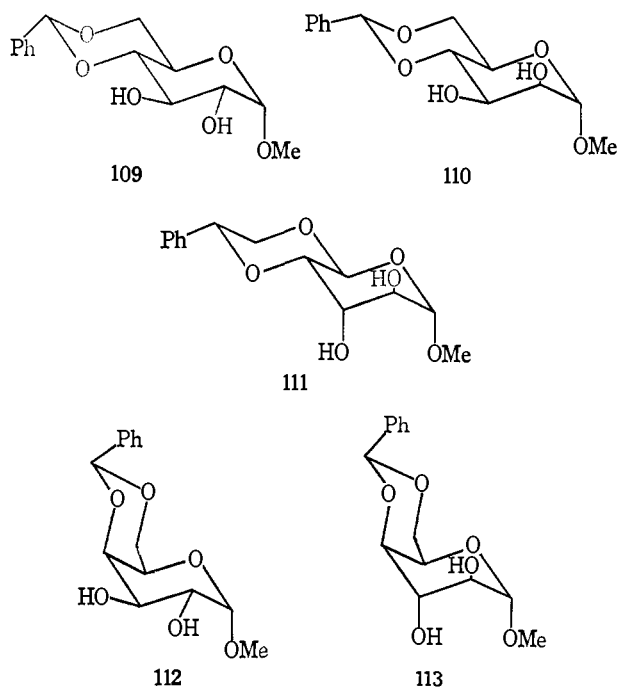

(372) G. N. Richards, *Chem. Ind.* (London), 228 (1955).

(373) B. Capon, W. G. Overend, and M. Sobell, *Tetrahedron*, 16, 106 (1961).

(374) J. Kovár and J. Jarý, *Collect. Czech. Chem. Commun.*, 32, 854 (1967); J. Kovár, F. Hanousehr, and J. Jarý, *ibid.*, 33, 630 (1968).

Under the conditions of hydrolysis the amino group is protonated, and it was proposed that this makes addition of a second proton to O(4) or O(6) more difficult.³⁷⁴

IX. Hydrolysis of Glycosylamines and Nucleosides

A. GLYCOSYLAMINES DERIVED FROM PRIMARY AMINES

The mechanism of the hydrolysis of glycosylamines derived from primary amines and ammonia has been more widely investigated than that of those derived from secondary and tertiary amines. These investigations have been hampered, however, from uncertainties in the structures of the glycosylamines and difficulties in estimating free aldose or amine in the presence of unhydrolyzed glycosylamine.

Isbell and Frush investigated the hydrolysis of an unsubstituted L-arabinosylamine, $[\alpha]_D +86.3^\circ$, which they considered to be pyranose but whose anomeric configuration they did not assign.³⁷⁵ In weakly alkaline aqueous solution the optical rotation decreases and then increases with time, and these changes were considered to result from anomerization and hydrolysis, respectively, and the rates of change in optical rotation were used to calculate rate constants for these processes at a series of pH's. The anomerization was very sensitive to acid catalysis and showed general acid catalysis but was only weakly catalyzed by bases (see Table XLII). This

Table XLII

Catalytic Constants for the Anomerization of L-Arabinosylamine at 20° (l. mole⁻¹ sec⁻¹)^a

$k(\text{H}_2\text{O})$	$<1.5 \times 10^{-5}$	$k(-\text{OH})$	1.5×10^{-3}
$k(\text{H}_3\text{O}^+)$	2.6×10^6	$k(\text{NH}_4^+)$	3.8×10^{-4}

^a See footnote to Table IX.

contrasts strongly with the anomerization of aldoses which are much more strongly catalyzed by bases than by acids. If the anomerization of the arabinosylamine proceeds *via* a concerted process, bond breaking between C(1) and the ring oxygen must therefore run ahead of removal of the proton from the nitrogen in the transition state, which is reasonable; Isbell and Frush preferred separate stepwise mechanisms for the acid- and base-catalyzed reactions, however.

The pH-rate profile for the hydrolysis of the pseudo-equilibrium mixture of arabinosylamines is bell shaped with a maximum at about pH 5 (Figure 4). A mechanism involving hydrolysis of the Schiff base which is an intermediate in the anomerization seems most likely and the whole process can be formulated as shown in eq 33, although it is possible that furanose forms of the arabinosylamines may be present also.

The anomerization and hydrolysis of two D-galactosylamines, thought to be α - and β -pyranose forms,³⁷⁶ and of D-glucosylamine, D-mannosylamine, and D-xylosylamine³⁷⁷ were also investigated and shown to be similar to those of the

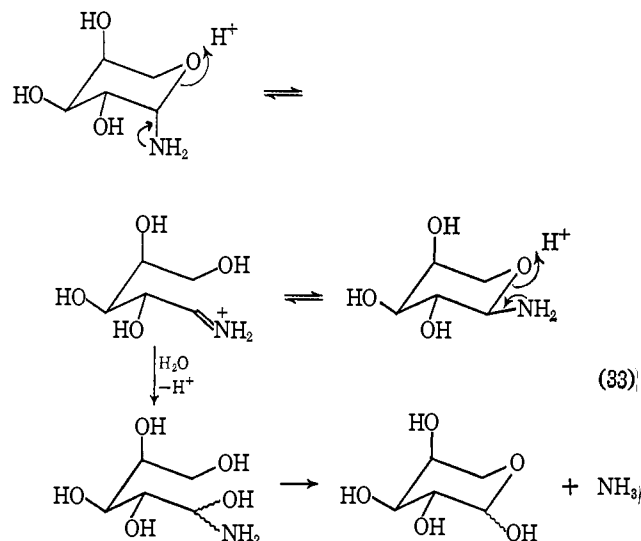

arabinosylamine. Qualitatively similar results were also obtained with *N*-phenylglucosylamine and some *N*-alkylglucosylamines for which it was found that hydrolysis proceeded more rapidly in aqueous acetic acid than in 0.5 *M* aqueous hydrochloric acid.³⁷⁸

More recently, Capon and Connett have investigated the hydrolysis of anomerically pure *N*-arylglucosylamines for which the pyranose structure was established by nmr and acetylation-deacetylation cycles.^{379, 380} Hydrolysis was followed spectrophotometrically and anomerization polarimetrically, and the former reaction for several glycosylamines was also studied by Simon and Palm³⁸¹ who measured the rate of liberation of amine by isotope dilution analysis. Hydrolysis was always preceded by anomerization to yield a mixture of about 10% α and 90% β form. The mechanism of eq 34 was suggested by Stepanenko, Ignatyuk-Maistrenko, and Chentsova³⁸² who studied the hydrolysis of *N*-*p*-carboxyphenylglucosylamine, galactosylamine, xylosylamine, and arabinosylamine in unbuffered solutions and found that the relative rates were similar to those of the corresponding *O*-glycosides, and concluded therefore that the two reactions proceeded by similar mechanisms. This mechanism seems unlikely, however, since the hydrolysis are general acid catalyzed and the pH-rate profiles show sharp maxima (see Figure 5). The mechanism of eq 35 therefore seems more likely. This involves hydrolysis of the Schiff base which must be an intermediate in the anomerization. The hydrolyses of Schiff bases normally show general acid catalysis^{383, 384} which is in fact the kinetically equivalent specific acid-general base catalysis.³⁸⁵ The maxima in the pH-rate profiles which move to higher acidities with decreasing basicity of the amine can be explained as resulting from a change in the rate-determining step of the hydrolysis of the Schiff-base form from attack

(375) H. S. Isbell and H. L. Frush, *J. Res. Nat. Bur. Stand.*, **46**, 132 (1951).

(376) H. L. Frush and H. S. Isbell, *ibid.*, **47**, 239 (1951).

(377) H. S. Isbell and H. L. Frush, *J. Org. Chem.*, **23**, 1309 (1958).

(378) W. Pigman, E. A. Cleveland, D. H. Couch, and J. H. Cleveland, *J. Amer. Chem. Soc.*, **73**, 1976 (1951).

(379) B. Capon and B. E. Connett, *J. Chem. Soc.*, 4492 (1965).

(380) B. Capon and B. E. Connett, *ibid.*, 4497 (1965).

(381) H. Simon and D. Palm, *Chem. Ber.*, **98**, 433 (1965).

(382) B. N. Stepanenko, V. A. Ignatyuk-Maistrenko, and M. G. Chentsova, *Dokl. Akad. Nauk SSSR*, **154**, 650 (1964).

(383) A. V. Willi and R. E. Robertson, *Can. J. Chem.*, **31**, 361 (1953).

(384) A. V. Willi, *Helv. Chim. Acta*, **39**, 1193 (1956).

(385) E. H. Cordes and W. P. Jencks, *J. Amer. Chem. Soc.*, **85**, 2843 (1963).

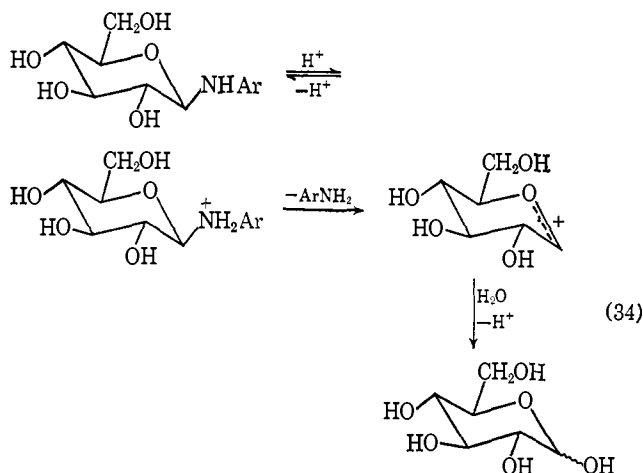

by water or hydroxide ion (step 1 of eq 35) to decomposition of the carbinolamine intermediate (step 2 in eq 35) (cf. ref 385).

Consistent with the mechanism of eq 35, the anomeric composition of the glucose formed in the hydrolysis of *N-p*-hydroxyphenyl- and *N-p*-tolylglucosylamines was found to be $62 \pm 5\%$ α and $38 \pm 5\%$ β , which is the composition expected from the ring closure of *aldehydo*-glucose ($64 \pm 2\%$ α and $36 \pm 2\%$ β) as calculated from the rate constants for these reactions, determined polarographically.³⁸⁶ There is also the possibility that the final step is an intramolecular displacement,³⁸¹ but in the reviewer's opinion this is more likely to involve formation of a five- than a six-membered ring.

Kinetic studies on the mutarotation of arylglucosylamines in methanol,³⁸⁷ and methanol-dioxane mixture,³⁸⁸ of the formation of glucosylamines,³⁸⁹ and of transglycosidation reactions³⁹⁰ have also been reported.

B. GLYCOSYLAMINES DERIVED FROM SECONDARY AMINES

The only detailed kinetic investigation on the hydrolysis of this class of compounds so far is with *N*- β -D-glucopyranosylpiperidine (114).³⁸¹ This reaction shows buffer catalysis and a maximum in the pH-rate profile at pH 4-5. It is thus very similar kinetically to the hydrolysis of glucosylamines derived from primary amines, and a similar mechanism (eq 36) is probably followed. As first pointed out by Kenner,³⁹¹ a mechanism involving protonation on nitrogen followed by heterolysis to a glycosyl cation is unlikely as the glycosyltrimethylammonium ion is quite stable.³⁹²

C. NUCLEOSIDES

The hydrolyses of nucleosides, of which there have been surprisingly few investigations of mechanistic significance, are acid catalyzed. The first question to be decided concerning

(386) J. M. Los, L. B. Simpson, and K. Wiesner, *J. Amer. Chem. Soc.*, **78**, 1564 (1956).

(387) T. Jasiński, K. Smiatczowa, and J. Sokolowski, *Rocz. Chem.*, **39**, 827 (1965); **42**, 115 (1968); T. Jasiński, K. Smiatczowa, T. Sokolowska, and J. Sokolowski, *ibid.*, **42**, 313 (1968).

(388) T. Jasiński and K. Smiatczowa, *Rocz. Chem.*, **40**, 1273 (1966).

(389) J. Sokolowski and S. Kolka, *ibid.*, **37**, 827 (1965).

(390) R. Bognár, P. Nánási, and M. Puskás, *J. Chem. Soc.*, 320 (1961).

(391) G. W. Kenner, Ciba Foundation Symposium on the Chemistry and Biology of Purines, 1957, p 312.

(392) P. Karrer and J. ter Kuile, *Helv. Chim. Acta*, **5**, 870 (1922).

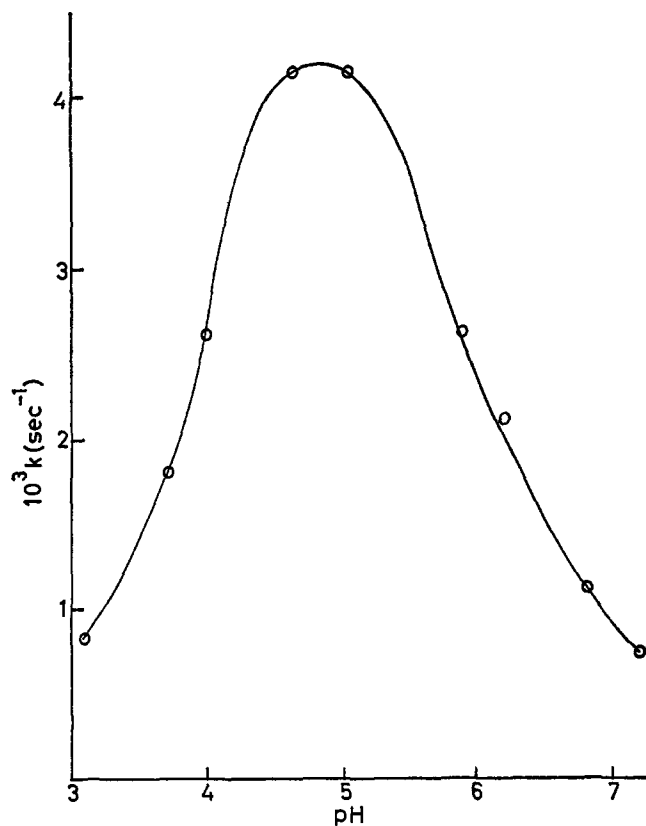

Figure 4. The dependence on pH of the rate constant for the hydrolysis of L-arabinosylamine.

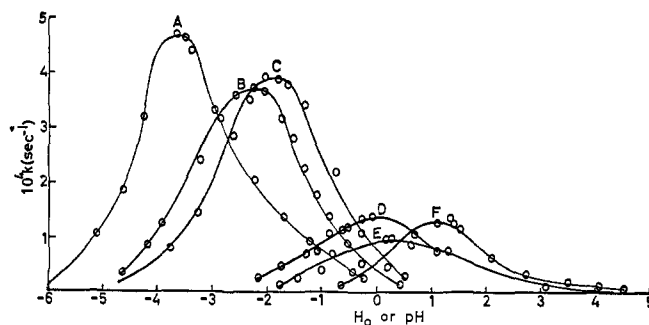
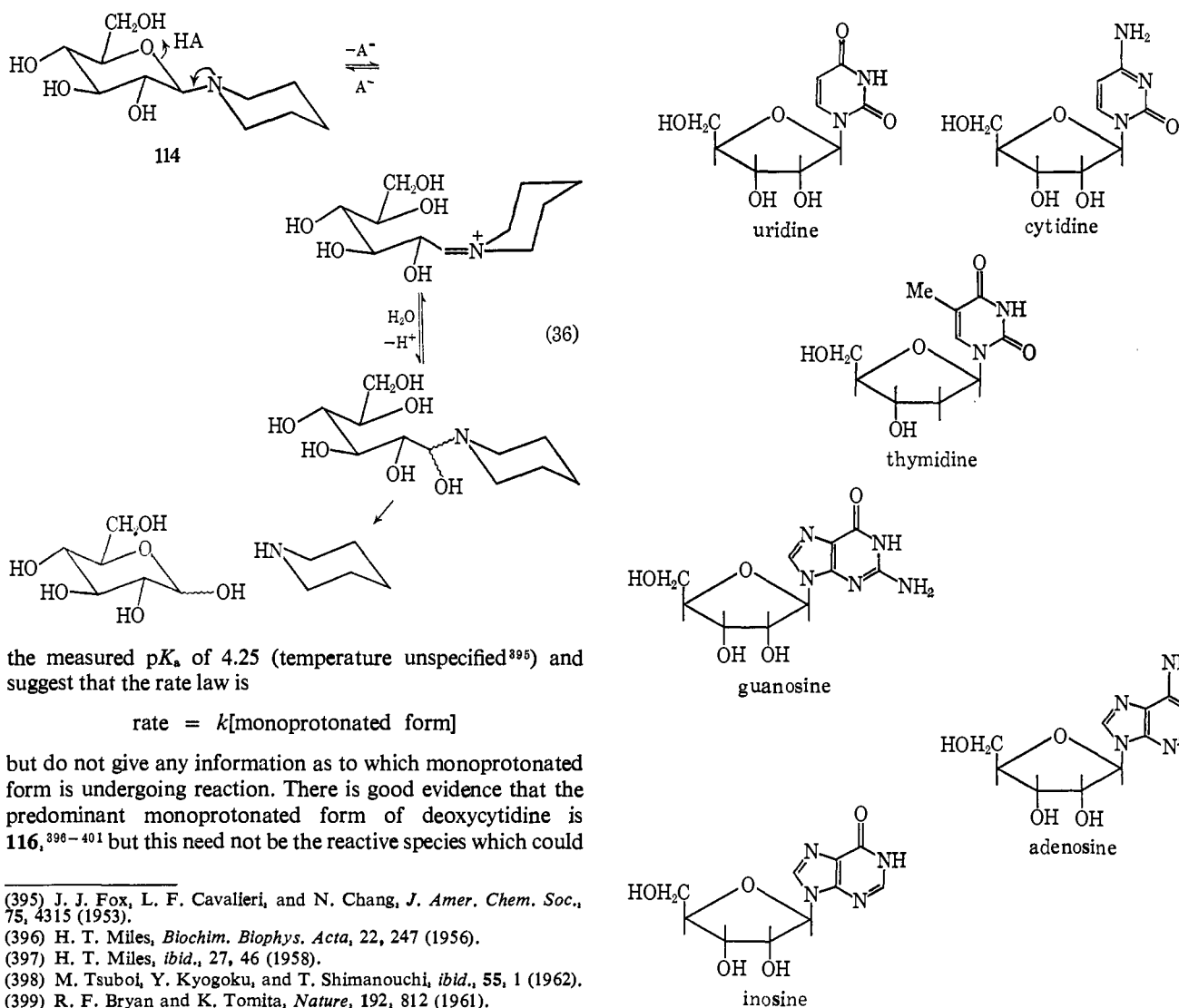
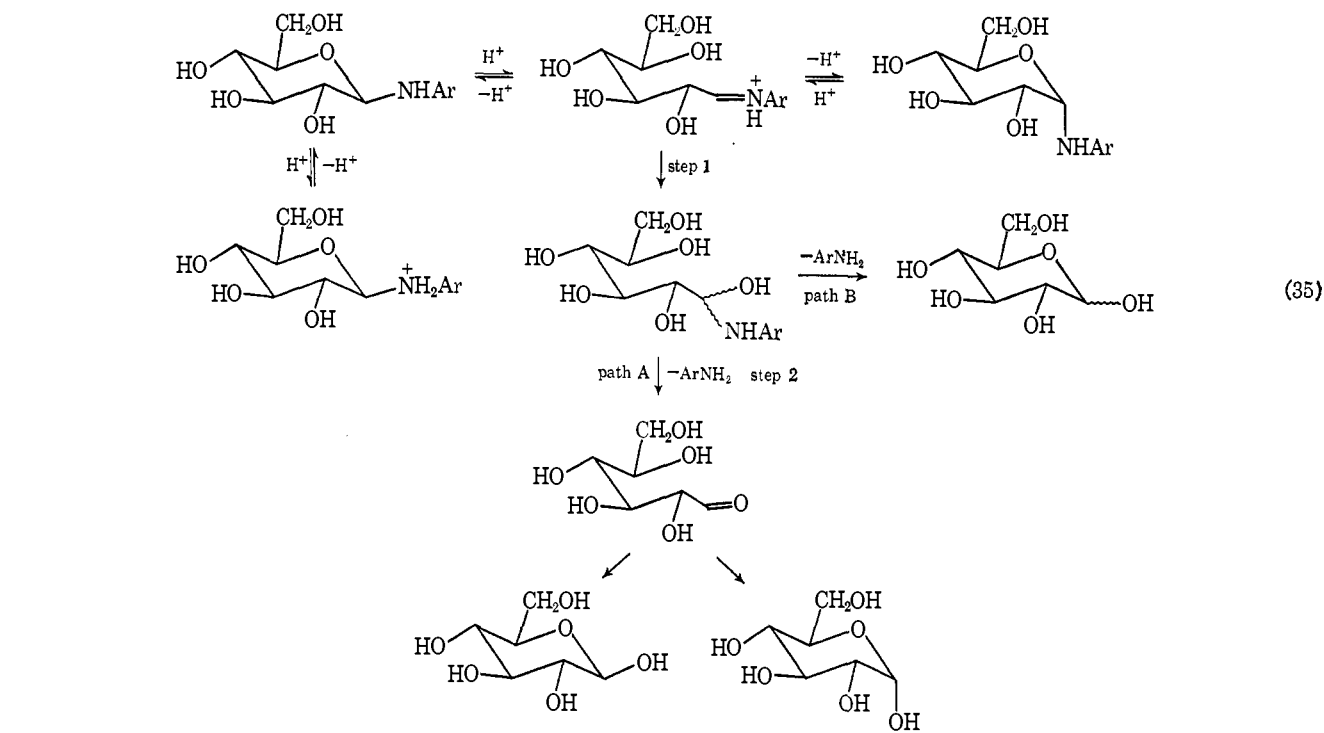

Figure 5. The dependence on pH and H_0 of the rate constant for the hydrolysis of *N*-aryl-D-glucosylamines at 25°C: (A) *p*-nitrophenyl, (B) *p*-carboxyphenyl, (C) *p*-trifluoromethylphenyl, (D) phenyl; (E) *p*-tolyl, (F) *p*-hydroxyphenyl.

the mechanism is whether a mono- or diprotonated form is the reactive species and which of the several such conjugate acids this is. Information on the first point should be given by the dependence of rate on acid concentration, but this has only been studied for a few nucleosides. One of the most thoroughly investigated is deoxycytidine (115)^{393,394} which gives an approximately sigmoidal pH-rate profile with apparent pK_a 's of 4.4 at 37° and 3.18 at 67°, and the rate is independent of pH below about pH 2.5.³⁹⁴ These values are reasonably close to

(393) H. Venner, *Z. Physiol. Chem.*, **339**, 14 (1964).

(394) H. Venner, *ibid.*, **344**, 189 (1966).



the measured pK_a of 4.25 (temperature unspecified³⁹⁵) and suggest that the rate law is

$$\text{rate} = k[\text{monoprotonated form}]$$

but do not give any information as to which monoprotonated form is undergoing reaction. There is good evidence that the predominant monoprotonated form of deoxycytidine is **116**,³⁹⁶⁻⁴⁰¹ but this need not be the reactive species which could

(395) J. J. Fox, L. F. Cavalleri, and N. Chang, *J. Amer. Chem. Soc.*, **75**, 4315 (1953).

(396) H. T. Miles, *Biochim. Biophys. Acta*, **22**, 247 (1956).

(397) H. T. Miles, *ibid.*, **27**, 46 (1958).

(398) M. Tsuboi, Y. Kyogoku, and T. Shimanouchi, *ibid.*, **55**, 1 (1962).

(399) R. F. Bryan and K. Tomita, *Nature*, **192**, 812 (1961).

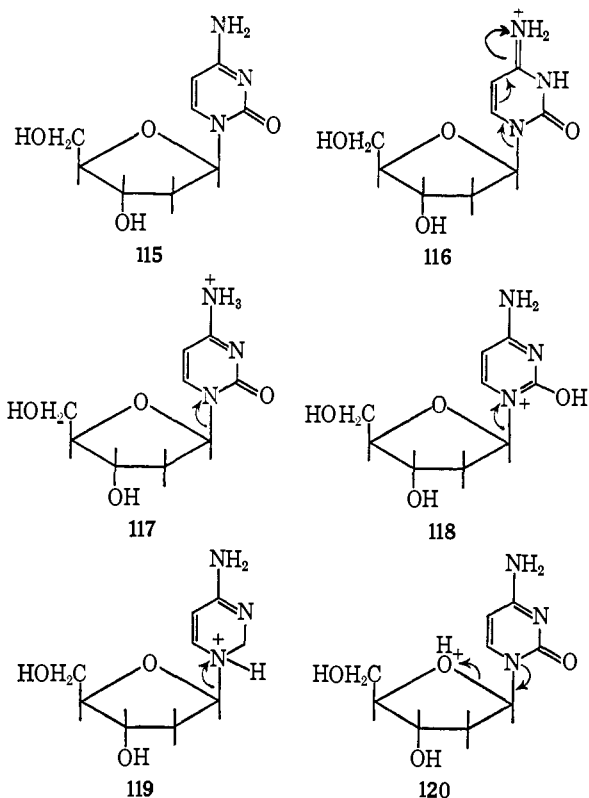

be one of the other possible monoprotinated forms **117** to **120**. All of these should be hydrolyzed more rapidly than the unprotonated form since protonation will facilitate the electron flow as symbolized by the arrows in these formulas.

Several workers have taken the view that the hydrolysis involves conjugate acid **120** and proceeds with ring opening.^{391, 402-405} The main argument for this is analogy to the mechanism of hydrolysis of glycosylamines. One cannot be sure that this analogy is valid, however. The important factor which facilitates ring opening with glycosylamines is the mesomeric electron release of the amino nitrogen as symbolized by **121**. With nucleosides the nitrogen is not amino but amido (**122**) or amidino (**123**) and will release electrons in this way much less readily, and hence the mechanism may be different. It is significant perhaps that the few pH-rate pro-

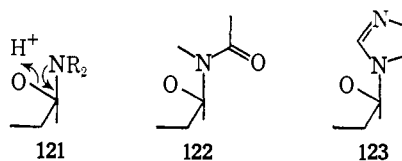

files determined for nucleosides so far are quite different from the bell-shaped curves found with glycosylamines.³⁹⁴

It has also been suggested that the conjugate acid protonated on the ring oxygen of the sugar is formed by proton transfer from a conjugate acid protonated on the base.^{391, 395, 402} There is little evidence to support this speculation, however. It has

been claimed⁴⁰² that the greater rate of hydrolysis of isocytidine compared to cytidine and the rapid hydrolysis of ribosylimidazoles with a 5-amino substituent⁴⁰⁶ provide support, since with these the proton in the conjugate acid lies close to the ring oxygen of the sugar. In the reviewer's opinion the possibility that electronic effects are the cause of these enhanced rates should be eliminated before resource is made to explanations involving intramolecular proton transfer. At present it is not possible to attempt to do this since there have been so few kinetic measurements.

The rate of hydrolysis of thymidine, deoxyuridine, and several 5-substituted deoxyuridines are approximately proportional to the acid concentration over the limited range of acidities so far studied (see Tables XLIII and XLIV), suggest-

Table XLIII

Variation of the Rate of Hydrolysis of Thymidine and 2-Deoxyuridine with Acidity³⁹⁴

	Acid, 0.1 M			
	Hydrochloric	Formic	Acetic	
Thymidine at 67°				
pH	1.48	2.30	2.98	
10 ⁶ k, sec ⁻¹	32.6	5.44	1.44	
2-Deoxyuridine in Hydrochloric Acid at 70°				
Concn, M	0.928	0.743	0.459	0.244
10 ⁶ k	3.34	2.48	1.75	0.914

ing that monoprotinated forms are reactive species. The pyrimidine rings of these compounds are weakly basic, and the sites of protonation are not known. General acid catalysis could not be detected in the hydrolysis of 5-iododeoxyuridine in acetate buffers.⁴⁰⁷ The effect of all the substituents so far investigated in position 5 of deoxyuridine is to increase the rate of hydrolysis although the effects are not large (see Table XLIV). The change from the slightly positive entropies of activation obtained with the unsubstituted and halogeno-substituted compounds to the negative values obtained with the hydroxyl- and methyl-substituted compounds is difficult to understand. At present it cannot be decided if an A1 or an A2 mechanism is being followed and whether or not ring opening is occurring in a rate-determining step. The absence of general acid catalysis, of a maximum in the plot of rate constant against pH, and apparently of anomerization concurrent with hydrolysis suggests, however, that the mechanism of hydrolysis of these nucleosides is different from that of glycosylamines.

Dihydropyrimidine nucleosides have been reported to be hydrolyzed more rapidly than the corresponding unhydrogenated compounds. It has been pointed out⁴⁰⁸ that with dihydrocytidine a resonance structure cannot be written for the conjugate acid which carries a positive charge at N(3) like that which can be written for cytidine, *i.e.*, **124**. It was therefore suggested that with dehydrocytidine approach of a second proton, and hence hydrolysis, occurs much more readily. However, as the rate of hydrolysis of cytidine appears to be

(400) T. L. V. Ulbricht, *Tetrahedron Lett.*, 1027 (1963).

(401) H. T. Miles, *J. Amer. Chem. Soc.*, 85, 1007 (1963).

(402) C. A. Dekker, *Ann. Rev. Biochem.*, 29, 463 (1960).

(403) T. L. V. Ulbricht, *Comp. Biochem.*, 8, 196 (1963).

(404) E. R. Garrett, J. K. Seydel, and A. J. Sharp, *J. Org. Chem.*, 31, 2219 (1966).

(405) A. M. Michelson, "The Chemistry of Nucleosides and Nucleotides," Academic Press, London, 1963, p 26.

(406) J. M. Buchanan, ref 391, p 327.

(407) E. R. Garrett, T. Suzuki, and D. J. Weber, *J. Amer. Chem. Soc.*, 86, 4460 (1964).

Table XLIV

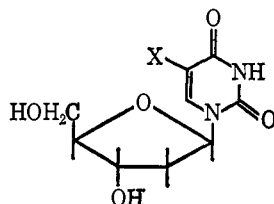
Entropies of Activation and Dependence of Rates on Acidity for the Hydrolyses of 5-Substituted Deoxyuridines in Hydrochloric Acid at 80°⁴⁰⁴

[HCl], M	$10^6 k, \text{sec}^{-1}$						
	H	F	Cl	Br	I	OH	Me ^e
1.10	1.38	46.5	44.2	48.0	39.5	154 ^e	23.6 ^e
0.75		33.5	31.0	30.9		120	18.3
0.50		22.7	24.5 ^a	20.6		79.5	12.5 ^a
0.40						61.7	
0.27		9.95	12.2 ^b	10.7		39.2 ^d	6.58
0.2						30.1	
0.1						19.8	
$\Delta S^\ddagger, \text{eu}^\dagger$	5.1	8.3	5.6	11.4	5.2	-22.9	-11.2
$E_a, \text{kcal mole}^{-1}$	31.2	31.5	30.6	32.6	30.5	19.5	25.0

^a In 0.565 M HCl. ^b In 0.283 M HCl. ^c In 0.98 M HCl. ^d In 0.25 M HCl. ^e Thymidine. ^f Calculated by the reviewer.

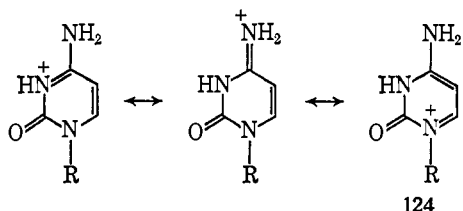

first order in unprotonated cytosine and only first order in acid concentration (see above), this explanation should be viewed with caution.

Purine nucleosides are hydrolyzed much more rapidly than pyrimidine nucleosides as is seen from a comparison of the rates of hydrolysis of deoxyguanosine and deoxyadenosine with that of deoxycytidine, one of the more rapidly hydrolyzed⁴⁰⁸ pyrimidine nucleosides (see Table XLV). The most

Table XLV

First-Order Rate Constants for the Hydrolysis of Nucleosides in Aqueous Perchloric Acid at 37°³⁹³

Nucleoside	pH	$10^7 k, \text{sec}^{-1}$
Deoxyguanosine	0.97	9.72×10^8
Guanosine	0.97	18.9
Deoxyadenosine	0.69	1.23×10^4
Adenosine	0.69	18.9
Deoxycytidine	0.78	1.92

thoroughly investigated purine nucleoside is, however, the ketonucleoside, psicofuranine (125).^{409,410} The hydrolysis is specific acid catalyzed, and at 50° in the pH range 6–1 the rate follows a law of the form

$$\text{rate} = k_1[\text{monoprotonated form}][\text{H}_3\text{O}^+] + k_2[\text{unprotonated form}][\text{H}_3\text{O}^+]$$

with $k_1 = 2.75 \times 10^{-2} \text{ l. mole}^{-1} \text{ sec}^{-1}$, $k_2 = 7.4 \times 10^{-2} \text{ l. mole}^{-1} \text{ sec}^{-1}$, and the dissociation constant of the monoprotonated conjugate acid $K_a = 1.59 \times 10^{-4} \text{ mole l.}^{-1}$. Both mono- and diprotonated forms are therefore undergoing hydrolysis. The predominant monoprotonated form of psicofuranine is probably 126, analogous to that of adeno-

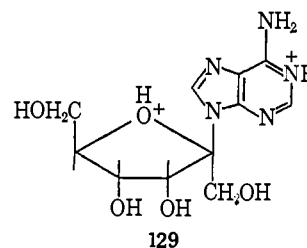
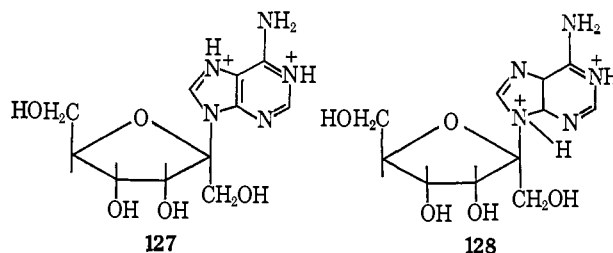
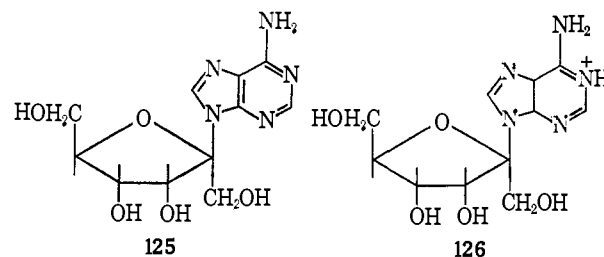

(408) E. Marinello and G. Quadri, *Ital. J. Biochem.*, **13**, 178 (1964).

(409) E. R. Garrett and L. J. Hanka, *J. Amer. Pharm. Assoc.*, **49**, 526 (1960).

(410) E. R. Garrett, *J. Amer. Chem. Soc.*, **82**, 827 (1960).

sine,^{398, 411} but this of course is not necessarily the reactive species. Possible reactive diprotonated species are **127–129**, and the most stable of these would probably be **127**. It is difficult to decide, however, if this would be sufficiently reactive for hydrolysis to proceed *via* it rather than *via* **128** or **129**.

The rates of hydrolysis of adenosine, $pK_a = 3.55$,⁴¹² and deoxyadenosine also do not approach a steady value in the pH range 2–3^{393, 413} as would be expected if only monoprotonated forms were reactive species, and hydrolysis *via* a diprotonated form probably occurs as well. Adenosine is hydrolyzed 10^3 – 10^4 times more slowly than psicofuranine. This rate difference is similar to that found with aldo- and ketoglycosides (see section III.B) and presumably results from the tertiary ketoglycosyl cation being more stable than the secondary aldoglycosyl one.

The pK_a of guanosine is 1.6,⁴¹² and protonation is thought to occur at position 7 as shown in formula **130**.^{398, 411} Un-

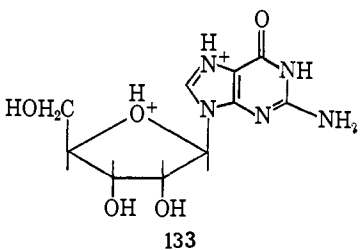
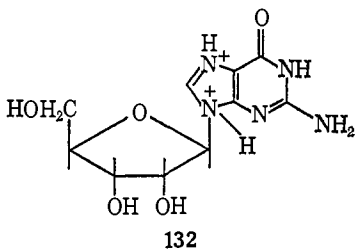
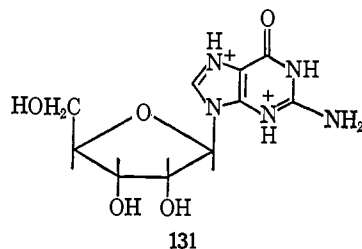
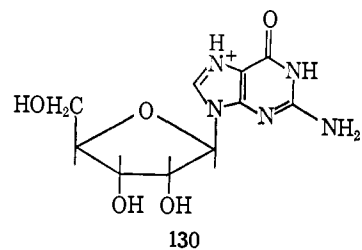

fortunately the pH dependence of its rate of hydrolysis and that for deoxyguanosine have only been followed down to pH 0.97, but there appears to be no falling off in the increase in rate with increased acidity as would be expected if only

monoprotonated forms were the reactive species. Provided then that salt effects are not important, a diprotonated form must also be undergoing reaction and this could be **131**, **132**, or **133**. The hydrolysis of imidazole and benzimidazole nucleosides are discussed in ref 414.

Nucleosides of 2-deoxyribose are hydrolyzed much more rapidly than those of ribose (see Tables XLV and XLVI⁴¹⁵).

Table XLVI

First-Order Rate Constants for the Hydrolysis of Nucleosides in 1 M Hydrochloric Acid at 100°C⁴¹⁵

	$10^4 k_1$ sec^{-1}	$t_{1/2}$ min
Uridine	2% hydrolysis in 5 hr	
2'-Deoxyuridine	1.14	104
2',3'-Dideoxyuridine	14.5	8.2
Thymidine	2.33	56
3'-Deoxythymidine	15.5	7.5

This high reactivity is similar to that of the glycosides of 2-deoxy sugars (see section II.A.2). Replacement of the hydroxyl group at the 2' position of nucleosides by hydrogen would be expected to have a rate-enhancing effect since the electron-withdrawing inductive effect of the former should cause a rate decrease whether the rate-determining step involved ring opening (**134**) or cleavage of the C–N bond (**135**). Substitution

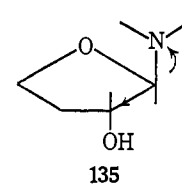
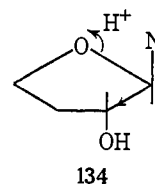

of a more strongly electron-withdrawing group than hydroxyl at C(2) causes the rate of hydrolysis to be even slower. Thus 2'-*p*-nitrobenzenesulfonyl-adenosine is "completely stable under conditions in which adenosine is completely hydrolyzed."⁴⁰³

The effect of the hydroxyl group at position 3' is as expected, smaller than that at position 2' but still appreciable since 2',3'-dideoxynucleosides are hydrolyzed more rapidly than 2'-deoxynucleosides (see Table XLVI). Methylation of the O(2') and O(3') of uridine results in a three- to sevenfold decrease in the rate of hydrolysis.⁴¹⁶

The effect of changing the configuration and ring size of the sugar has been little investigated. Inversion of configuration at position 3' of deoxyuridine causes a two- to threefold increase in rate. The adenine and uracil nucleosides of ribo- and glucopyranose are hydrolyzed more slowly than those of ribofuranose.⁴¹⁷

Nucleotides of adenosine, guanosine, deoxyadenosine, and deoxyguanosine undergo hydrolysis with preferential fission of the N-glycosidic bond and the phosphate groups have only small effects on the rates.^{394, 408}

(411) C. D. Jardetzky and O. Jardetzky, *J. Amer. Chem. Soc.*, **82**, 222 (1960).

(412) B. I. Sukhorukov, V. I. Polter, and L. A. Blyumenfel'd, *Bio-phys. J.*, **9**, 287 (1964).

(413) H. Venner, *Abh. Deut. Akad. Wiss. Berlin Kl. Med.*, **45** (1964); *Chem. Abstr.*, **62**, 14971b (1965).

(414) S. G. A. Alivisatos, L. La Mantia, and B. L. Matijevitch, *Biochim. Biophys. Acta*, **58**, 209 (1962).

(415) K. E. Pfitzner and J. G. Moffatt, *J. Org. Chem.*, **29**, 1508 (1964).

(416) Y. Furukawa, K. Kobayashi, Y. Kanai, and M. Honjo, *Chem. Pharm. Bull. (Tokyo)*, **13**, 1273 (1965).

(417) F. Micheel and A. Heising, *Chem. Ber.*, **94**, 1814 (1961).

The discussion presented here shows how very complex the hydrolysis of nucleosides is, the paucity of experimental work, and how inadequate is our understanding of the mechanisms. The following points should be borne in mind by future investigators: (a) that any analogy drawn between the hydrolysis of nucleosides and of glycosylamines is of dubious validity; (b) that different nucleosides may undergo hydrolysis by different mechanisms, and thus the assignment of a mechanism for any particular nucleoside should be considered as an independent problem.

X. Mutarotation of Aldoses and Ketoses

A. SIMPLE MUTAROTATIONS

Freshly prepared aqueous solutions of aldoses and ketoses frequently mutarotate as a result of the interconversion of cyclic and acyclic forms. These reactions may also be followed by the changes in refractive index,⁴¹⁸ volume,^{418, 419} nmr⁴²⁰ and infrared⁴²¹ spectra, and pH⁴²² which also occur. The rotational change shown by the α - and β -pyranose forms of lactose,⁴²³ glucose,^{424, 425} mannose,^{426, 427} lyxose,⁴²⁷ and xylose^{427, 428} obey the rate law for a first-order reversible reaction, and hence the reaction occurring is assumed to be the interconversion of pyranose forms without the intervention of a high concentration of any other form. However, the reaction for glucose, and presumably for the other sugars as well, must proceed with ring opening *via* a small concentration of acyclic form (eq 37). The best evidence for this is the observation that glucose-1-¹⁸O undergoes oxygen exchange with water more

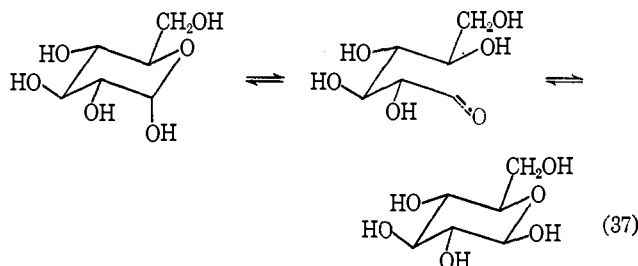

than 30 times slower than the mutarotation reaction,^{429, 430} thus excluding the only other reasonable pathway, *i.e.*, one involving exchange of the hydroxyl group at C(1) with water (eq 38). This result also excludes the formation of an aldehydrol form, 136, as a necessary intermediate in the mutarotation reaction. The oxygen exchange itself, which is acid and base catalyzed probably does proceed *via* this intermediate

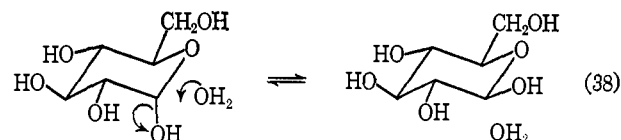

though. The only reasonable alternative pathway is that of eq 38, but this does not seem very likely since it is analogous to that for glycoside hydrolysis which occurs only slowly at neutral pH's where oxygen exchange is quite rapid.

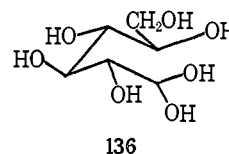

It therefore appears that in water α - and β -D-glycopyranose undergo ring opening to yield the aldehydo form and that generally the aldehydo group is captured by the hydroxyl at C(5) to re-form the hemiacetal linkage. One time in 15, however, or less frequently, the aldehydo group is captured by water to yield the aldehydrol compound, and approximately half the times this happens oxygen exchange results. There is also the possibility that the aldehydo group is captured by the hydroxyl at C(4) which would yield furanose derivatives, and from our knowledge of the relative rates of formation of five- and six-membered rings (*cf.* ref 187) it would be expected that furanose derivatives would be formed at least as rapidly as pyranose. The thermodynamic stabilities of the furanose forms of glucose are low, however, so if they are formed they presumably undergo ring opening rapidly to give the aldehydo form back again.

The mechanism given in eq 37 for the mutarotation reaction is consistent with the observed general acid and general base catalysis, first demonstrated with α -D-glucose by Brønsted and Guggenheim⁴¹⁹ who used a dilatometric method to follow the reaction and by Lowry and Smith⁴³¹ who used a polarimetric method. It was shown that in a buffer solution the rate constant could be expressed as

$$k_{\text{obsd}} = k_0 + k_{\text{H}_3\text{O}^+}[\text{H}_3\text{O}^+] + k_{-\text{OH}}[-\text{OH}] + k_{\text{A}}[\text{A}] + k_{\text{B}}[\text{B}]$$

where A and B are the acidic and basic forms of the buffer. By working with dilute solutions of hydrochloric and perchloric acids, Brønsted and Guggenheim determined k_0 and $k_{\text{H}_3\text{O}^+}$ to be $5.30 \times 10^{-3} \text{ min}^{-1}$ and $0.145 \text{ l. mole}^{-1} \text{ min}^{-1}$, respectively, at 18° , and they also showed that these were not sensitive to salt effects.

The determination of $k_{-\text{OH}}$ is more difficult since in alkaline solution the glucose itself is appreciably ionized and the resulting glucosate ion is catalytically active.⁴³² Taking account of this and using the change in pH accompanying the mutarotation reaction to measure the rate, Los and Simpson⁴²² obtained the values 3800, 1500, and $350 \text{ l. mole}^{-1} \text{ min}^{-1}$ for $k_{-\text{OH}}$ at 25, 15, and 0° (for other estimates see ref 433-435). The reaction is thus considerably more susceptible to catalysis by $-\text{OH}$ than by H_3O^+ . It is of interest that the difference in $\text{p}K_{\text{a}}$ between α - and β -glucose is sufficient for the glucose to

(418) C. N. Riiber, *Chem. Ber.*, **55**, 3132 (1922); **56**, 2185 (1923); **57**, 1599 (1924).

(419) J. N. Brønsted and E. A. Guggenheim, *J. Amer. Chem. Soc.*, **49**, 2554 (1927).

(420) R. W. Lenz and J. P. Heeschen, *J. Polymer Sci.*, **51**, 247 (1961).

(421) F. S. Parker, *Biochim. Biophys. Acta*, **42**, 513 (1960).

(422) J. M. Los and L. B. Simpson, *Rec. Trav. Chim.*, **73**, 941 (1954).

(423) C. S. Hudson, *Z. Physik. Chem.*, **44**, 487 (1903).

(424) T. M. Lowry, *J. Chem. Soc.*, **75**, 212 (1899).

(425) T. M. Lowry, *ibid.*, **83**, 1314 (1903).

(426) C. S. Hudson and H. L. Sawyer, *J. Amer. Chem. Soc.*, **39**, 470 (1917).

(427) H. S. Isbell and W. W. Pigman, *J. Res. Nat. Bur. Stand.*, **18**, 141 (1937).

(428) C. N. Riiber and O. Bjerkli, *Kgl. Norske Videnskab. Selskabs Skrifter*, No. 5 (1936).

(429) T. Titani and K. Goto, *Proc. Imp. Acad. (Tokyo)*, **16**, 398 (1940); *Chem. Abstr.*, **35**, 1384 (1941).

(430) D. Rittenberg and C. Graff, *J. Amer. Chem. Soc.*, **80**, 3370 (1958).

(431) T. M. Lowry and G. F. Smith, *J. Chem. Soc.*, 2539 (1927).

(432) G. F. Smith, *ibid.*, 1824 (1936).

(433) G. F. Smith and M. C. Smith, *ibid.*, 1413 (1937).

(434) G. Kilde and W. F. K. Wynne-Jones, *Trans. Faraday Soc.*, **49**, 243 (1953).

(435) R. P. Bell and J. E. Prue, *ibid.*, **46**, 14 (1950).

exist almost completely in the β form in alkaline solution.⁴⁴⁶ The catalytic constants for a large number of acids and bases are collected in Table XLVII. It is seen that catalysis by bases is

Table XLVII

Catalytic Coefficients for the Mutarotation of D-Glucose in Water at 18° (min⁻¹)^{419 a}

	$10^3 k_A$	$10^3 k_B$
Trimethylacetic acid	2.0	31.4
Propionic acid	2.1	28.1
Acetic acid	2.4	26.5
Phenylacetic acid	2.8	26.0
Benzoic acid	...	15.2
<i>o</i> -Toluic acid	...	12.2
Glycolic acid	5.6	13.7
Formic acid	4.6	16.5
Mandelic acid	5.7	10.8
Salicylic acid	...	4.6
<i>o</i> -Chlorobenzoic acid	...	6.4
Chloracetic acid	6.8	5.4
Cyanoacetic acid	...	3.8

^a See also ref 444.

generally more effective than by their conjugate acids. This difference in the relative effectiveness of acid and base catalysis is even more marked with sugars in which the ring oxygen is replaced by sulfur whose mutarotation is (understandably) very insensitive to acid catalysis^{164, 437} (see also section IX.A).

The mutarotation reaction like other general base catalyzed reactions⁴³⁸ is mildly subject to steric hindrance. Thus 2,6-lutidine is a seven- to eightfold weaker catalyst than 2,4-lutidine although it is a slightly stronger base.⁴³⁹

A mechanistic problem which has received considerable attention and is still the subject of debate is the exact timing of three processes which must occur in the formation of aldehydoglucose from a pyranose form, namely, addition of a proton to the ring oxygen, breaking of the bond between C(1) and the ring oxygen, and removal of a proton from the hydroxyl group at C(1). These processes are similar to those occurring in the dehydration of an aldehyde hydrate,⁴⁴⁰ and the solvent deuterium isotope effects are similar.^{441a} Eigen has argued^{441b} for a concerted rather than a stepwise mechanism (eq 39) for both reactions, concerted being defined as a correspondence between the motions of the protons involved in the reaction within times $<10^{-10}$ sec.^{442, 443} With eq 39 one of the processes has to be assumed to be the slow step, rate constant

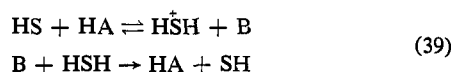

- (436) V. S. R. Rao and J. F. Foster, *J. Phys. Chem.*, **69**, 636 (1965).
 (437) J. C. P. Schwarz and K. C. Yule, *Proc. Chem. Soc.*, 417 (1961).
 (438) V. Gold, *Progr. Stereochem.*, **3**, 169 (1962).
 (439) F. Covitz and F. H. Westheimer, *J. Amer. Chem. Soc.*, **85**, 1773 (1963).
 (440) R. P. Bell, *Advan. Phys. Org. Chem.*, **4**, 1 (1966).
 (441) (a) H. H. Huang, R. A. Robinson, and F. A. Long, *J. Amer. Chem. Soc.*, **88**, 1866 (1966); (b) See, however, J. L. Kurz, *ibid.*, **89**, 3524 (1967); J. L. Kurz and J. I. Coburn, *ibid.*, **89**, 3528 (1967); R. P. Bell, J. P. Millington, and J. M. Pink, *Proc. Roy. Soc.*, **A303**, 1 (1968).
 (442) M. Eigen, *Angew. Chem. Intern. Ed. Engl.*, **3**, 19 (1964).
 (443) M. Eigen, *Discussions Faraday Soc.*, **39**, 7 (1965).

k^* , but plots of k^* against pK have a constant slope α (<1) and do not show the expected curvature when k^* approaches the diffusion-controlled limit. Concerted processes, possibly involving several water molecules (eq 40 and 41), were therefore proposed with the catalyst triggering the reaction and itself

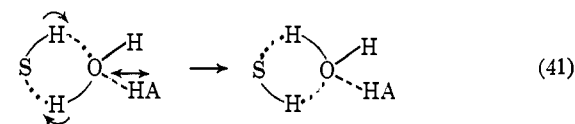
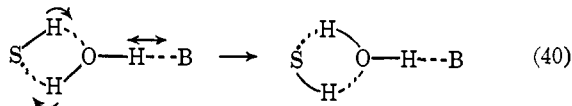

remaining essentially unchanged. It is not clear if this mechanism is compatible with the observed steric hindrance to the catalysis (see above), for with such a mechanism steric hindrance should be small since the catalyst is separated from the substrate by several water molecules.

It is of interest that on the grounds that the enthalpies of activation for catalysis of the mutarotation of α -glucose by anionic bases are similar to that for catalysis by water, it was suggested that catalysis takes place by way of the hydrate sheath of these ions.⁴⁴⁵ For a similar reason it was proposed that catalyses by acids are catalyses by water in which the solvent dipoles in the activated complex are "predirected by the acid."⁴⁴⁶⁻⁴⁴⁹

Support for a cyclic concerted mechanism for the mutarotation of 2,3,4,6-tetra-*O*-methyl- α -D-glucopyranose (TMG) has been obtained from the variation of rate constant with solvent composition in D_2O - H_2O mixtures^{441a} (see also ref 450). It was found that while cyclic and noncyclic concerted mechanisms could explain this rate dependence equally well using Salomaa, Schaleger, and Long's treatment,^{451, 452} very small fractionation factors were necessary with the latter and a cyclic transition state was therefore preferred.

In contrast to this discussion, other workers prefer a mechanism in which "transfer of the proton is *not* concerted with the rate-determining elimination of the alkoxide ion from the carbonyl group"⁴⁵³ (see also ref 441b, 454-456).

There is a small secondary isotope effect on the rate of mutarotation of D-glucose-1-*d* with $k_H/k_D = 1.12$ for the H_2O -catalyzed reaction and 1.09 for the H_3O^+ -catalyzed reaction.⁴⁵⁷

Mutarotation in nonaqueous solvents and in mixed solvents has also been extensively investigated. Lowry and Faulkner,

- (444) F. H. Westheimer, *J. Org. Chem.*, **2**, 431 (1937).
 (445) H. Schmid and G. Bauer, *Monatsh. Chem.*, **96**, 1503 (1965).
 (446) H. Schmid and G. Bauer, *ibid.*, **96**, 2010 (1965).
 (447) H. Schmid and G. Bauer, *ibid.*, **97**, 168 (1966); see also H. Schmid, *ibid.*, **98**, 2097 (1967).
 (448) H. Schmid, G. Bauer, and G. Prähauser, *ibid.*, **98**, 165 (1967).
 (449) H. Schmid and G. Bauer, *Z. Naturforsch.*, **21b**, 1009 (1966).
 (450) E. L. Purlee, *J. Amer. Chem. Soc.*, **81**, 263 (1959).
 (451) P. Salomaa, L. L. Schaleger, and F. A. Long, *ibid.*, **86**, 1 (1964).
 (452) P. Salomaa, L. L. Schaleger, and F. A. Long, *J. Phys. Chem.*, **68**, 410 (1964).
 (453) R. L. Schowen, H. Jayaraman, L. Kershner, and G. W. Zuorick, *J. Amer. Chem. Soc.*, **88**, 4008 (1966).
 (454) C. G. Swain and E. R. Thornton, *ibid.*, **83**, 3884 (1961).
 (455) B. C. Challis, F. A. Long, and Y. Pocker, *J. Chem. Soc.*, 4679 (1957).
 (456) Y. Pocker, *Chem. Ind. (London)*, 968 (1960).
 (457) N. C. Li, A. Kaganove, H. L. Crespi, and J. J. Katz, *J. Amer. Chem. Soc.*, **83**, 3040 (1961).

in a classic paper, showed that the mutarotation of glucose and tetramethylglucose is respectively about 20 and 40 times slower in pyridine than in water and that of tetramethylglucose in *m*-cresol 30 times slower than in water, but in mixtures of pyridine and *o*-cresol containing 55.0–92.5% *o*-cresol mutarotation was reported as being too fast for rate measurements.⁴⁵⁸ These experiments which showed the need for acidic and basic catalysts lead to the first suggestion that the mutarotation reaction is a concerted process⁴⁵⁹ (see also ref 460, 461) and were extended in the important and frequently quoted papers of Swain and Brown⁴⁶² who studied catalysis of the mutarotation of tetramethylglucose in benzene by 2-pyridone. The latter was written by the authors in the 2-hydroxypyridine form, and it was predicted that bifunctional catalysis by a molecule containing a phenolic and pyridine group might be much more effective than catalysis by separate pyridine and phenol molecules acting concertedly. The observed kinetics were complicated owing, it was thought, to the formation of a complex between the tetramethylglucose and the 2-pyridone whose presence was also indicated by the high initial and equilibrium rotations of the reaction solutions. The reported results are striking, with 0.05 *M* 2-pyridone giving an "observed rate" more than 50 times the "total rate" with 0.05 *M* pyridine and 0.05 *M* phenol, and with 0.001 *M* 2-pyridone and 0.1 *M* tetramethylglucose the rate was reported to be 7000 times that calculated for 0.001 *M* pyridine and 0.001 *M* phenol. It was also pointed out that 2-pyridone is more than ten times as powerful a catalyst in benzene solution as hydronium ion is in water.

The catalysis was formulated by Swain and Brown as shown in eq 42, the catalyst being written in the 2-hydroxypyridine form, but it was indicated that it could also be written as eq 43 if the catalyst were in the 2-pyridone form.

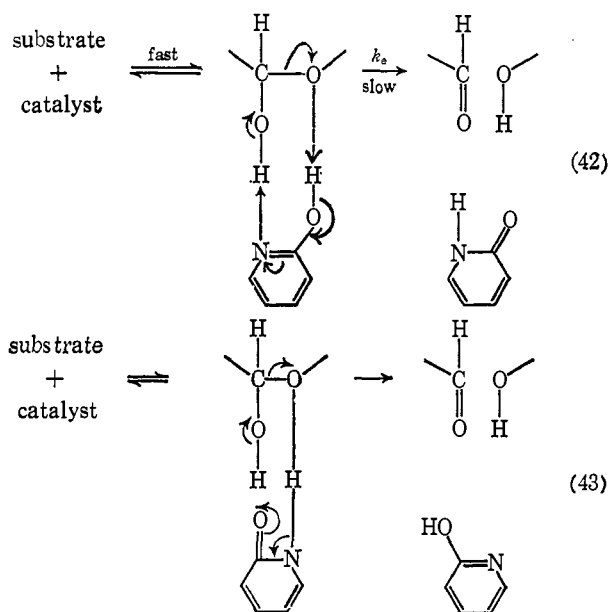

If the 2-hydroxypyridine form is the catalytically active species, it must be exceedingly active since it is normally only

present in very small concentration in polar and nonpolar solvents (see ref 463a).

Evidence that there was no compound formation between 2-pyridone and tetramethylglucose other than of a hydrogen-bonded complex was that evaporation of the reaction solution, dissolution in dilute hydrochloric acid, and extraction with chloroform yielded about 70% of the original tetramethylglucose and that extraction of the evaporated solution with light petroleum yielded 2-pyridone (recovery unspecified).⁴⁶²

It has been suggested that the mutarotation of tetramethylglucose in benzene solution is catalyzed by ion pairs formed from triethylamine and 2,4-dinitrophenol. The catalytic effect of 2,4-dinitrophenol alone is small, but that of an equimolar mixture of triethylamine and 2,4-dinitrophenol is much larger and the rate constant is proportional to the first power of the concentration of the mixture. At a constant triethylamine concentration of 5×10^{-3} mole l^{-1} , the rate constant increases with increasing dinitrophenol concentration up to the same concentration and then remains almost constant. The values of the catalytic constant for catalysis by ion pairs calculated from both sets of experiments were the same, supporting this hypothesis. Catalysis by tetra-*n*-butylammonium 2,4-dinitrophenoxide appears to be almost as effective as that by triethylammonium 2,4-dinitrophenoxide ion, and hence the rate enhancement probably results from a "salt effect" rather than from concerted acid-base catalysis.^{463b}

There have been a large number of measurements of the rate constants for the mutarotation of other aldoses besides glucose.^{464–466} Generally only those aldoses which can be regarded as being derived from xylose or lyxose by substitution at C(5) and their derivatives show simple mutarotation. The most noticeable trends in the rate constants for these (Table XLVIII) are that they decrease in the order pentose > 6-deoxypentose > hexose > heptose, and that those for sugars derived from lyxose are larger than those for the analogous sugars derived from xylose, but the variation in rate is not large.

B. COMPLEX MUTAROTATIONS

Our understanding of complex mutarotations is incomplete and will remain so until it is possible to identify the species present in solution and to measure their concentrations and the variation of their concentrations with time.^{467a} It seems reasonable to assume that furanose, aldehyde, and aldehydol as well as pyranose forms may be present. One of the most complex mutarotation curves is that of ribose shown in Figure 6,⁴²⁷ and clearly more than two species must be present at appreciable concentrations. An attempt to measure the concentration of the aldehyde form of ribose and of some other sugars was made by Cantor and Peniston using a polarographic method.^{467b} It was supposed that only the aldehyde form was being reduced at the dropping-mercury electrode and that the step height was a measure of the concentration

(458) T. M. Lowry and I. J. Faulkner, *J. Chem. Soc.*, 127, 2883 (1925).

(459) T. M. Lowry, *ibid.*, 129, 2554 (1927).

(460) K. J. Pedersen, *J. Phys. Chem.*, 38, 581 (1934).

(461) C. G. Swain, *J. Amer. Chem. Soc.*, 72, 4578 (1950).

(462) C. G. Swain and J. F. Brown, *ibid.*, 74, 2534, 2538 (1952).

(463) (a) A. R. Katritzky and J. M. Lagowski, *Advan. Heterocyclic Chem.*, 1, 339 (1963); (b) A. Kergomard and M. Renard, *Tetrahedron Lett.*, 769 (1968); see also P. R. Rony, *J. Amer. Chem. Soc.*, 90, 2824 (1968).

(464) H. S. Isbell, *J. Res. Nat. Bur. Stand.*, 18, 505 (1937).

(465) C. N. Riiber and N. A. Sørensen, *Kgl. Norske Videnskab. Selskabs, Skrifter*, No. 1 (1938).

(466) H. S. Isbell and W. W. Pigman, *J. Res. Nat. Bur. Stand.*, 18, 141 (1937).

(467) (a) But see A. H. Conner and L. Anderson, Abstracts, 157th National Meeting of the American Chemical Society, Minneapolis, Minn., April 1969, CARB-16; (b) S. M. Cantor and Q. P. Peniston, *J. Amer. Chem. Soc.*, 62, 2113 (1960).

Table XLVIII

Rate Constants for the Mutarotation of Aldoses in Aqueous Solution at 20°

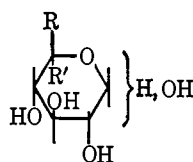

Aldose	R	R'	$10^4(k_1 + k_{-1})^b$
Aldoses Derived from D-Xylose			
D-Xylose	H	H	7.79
6-Deoxy-D-glucose	CH ₃	H	4.7
D-Glucose	HOCH ₂	H	2.43
6-O-Methyl-D-glucose	CH ₃ OCH ₂	H	2.67
L-Glycero-D-glucoheptose ^a	HOCH ₂ CHOH	H	0.757
Lactose (4-O-β-D-galactopyranosyl-D-glucose)			1.81
Maltose (4-O-α-D-glucopyranosyl-D-glucose)			2.02
Gentiobiose (6-O-β-D-glucopyranosyl-D-glucose)			3.28
Melibiose (6-O-α-D-galactopyranosyl-D-glucose)			3.38
Primeverose (6-O-β-D-xylosyl-D-glucose)			2.41
Vicianose (6-O-α-L-arabinosyl-D-glucose)			2.58

Aldoses Derived from D-Lyxose

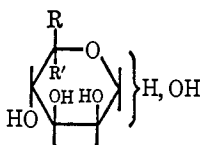

D-Lyxose	H	H	21.8
D-Rhamnase ^a	CH ₃	H	16.5
D-Mannose	HOCH ₂	H	6.13
L-Gulose ^a	H	HOCH ₂	7.56
L-Glycero-D-mannoheptose ^a	HOCH ₂ CHOH	H	1.80
L-Glycero-L-guloheptose ^a	H	HOCH ₂ -CHOH	3.06

^a Enantiomer actually studied. ^b See footnote to Table IX.

of this form. It was shown by Wiesner, however, that the reduction is not diffusion controlled, and hence the polarographic wave must depend on the rate of a process occurring at the mercury surface.⁴⁶⁸ According to Delahay and Strassner⁴⁶⁹ (see also ref 386, 470) this is the conversion of ring forms to an acyclic form with a rate constant k_s , measured by the limiting current. However, aliphatic aldehydes often give kinetic limiting currents (see ref 471), and this is also true of the aldehyde sugar 2,4:3,5-di-O-ethylidenealdehyde-L-xylose.⁴⁷² This has been explained as being due to a rate-de-

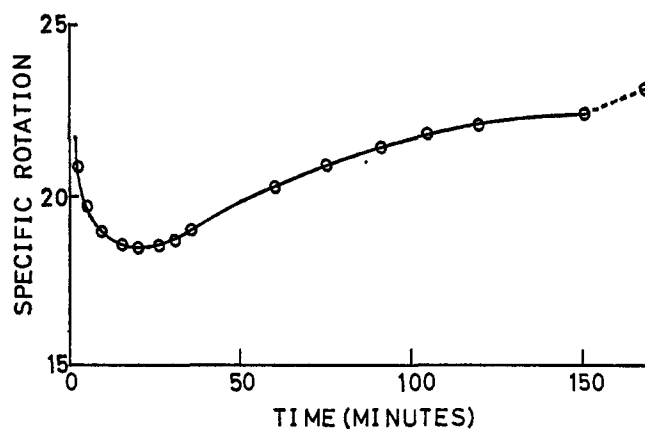

Figure 6. Plot of specific rotation of L-ribose against time in water at +0.2°.

termining dehydration of the aldehydrol form at the mercury surface. Hence it would appear that Cantor and Peniston's results can be explained equally well by either a low concentration of acyclic form and a rate-limiting ring opening of a cyclic form at the mercury surface or by an appreciable concentration of aldehydrol form with a rate-limiting dehydration step.

Tipson and Isbell measured the infrared spectra of the material obtained by freeze-drying fully mutarotated solutions of several aldoses including ribose and observed a band at 1718 cm⁻¹ which they attributed to the presence of aldehyde form.⁴⁷³ As pointed out by these workers though, it is not possible to extrapolate these results with any certainty to the forms actually present in solution.

Finally the nmr spectrum of ribose in deuterium oxide has been measured by Lenz and Heeschen,⁴²⁰ Rudrum and Shaw,⁴⁷⁴ and Lemieux and Stevens.¹⁰⁵ Lenz and Heeschen suggested that a signal in the spectrum of mutarotated ribose in D₂O at δ 3.44 was characteristic of an exocyclic hydroxymethylene group and hence indicated the presence of a furanose modification. Rudrum and Shaw and Lemieux and Stevens found that equilibrium solutions of ribose showed four signals attributable to anomeric protons at 5.42, 5.30, 4.91, and 4.99 ppm downfield from external tetramethylsilane. These were assigned to α - and β -furanose and α - and β -pyranose forms, respectively, and it was estimated that at equilibrium these were present in the ratio 6:18:20:56.

Rudrum and Shaw reported that their initial spectra at 30° indicated the presence of pyranose forms only and concluded that the initial rapid change in optical rotation of ribose corresponded to the interconversion of pyranose forms and that furanose forms were formed in a subsequent slower reaction. Unfortunately it is not clear if they were using a single anomeric form or a mixture as their starting material, but the latter does not seem unlikely since their sample was prepared by evaporation of a solution in D₂O, and this would of course invalidate their conclusion. If, however, it is correct it would mean that the intermediate aldehyde form (or the conformation of this which is an intermediate in the pyranose interconversion) is undergoing ring closure much more rapidly to give a six-membered than a five-membered ring. This would be

(468) K. Wiesner, *Collect. Czech. Chem. Commun.*, 12, 64 (1947).(469) P. Delahay and J. E. Strassner, *J. Amer. Chem. Soc.*, 74, 893 (1952).(470) J. M. Los and K. Wiesner, *ibid.*, 75, 6346 (1953).

(471) I. M. Kolthoff and J. J. Lingane, "Polarography," Vol. 2, Interscience Publishers, New York, N. Y., 1952, pp 652-698.

(472) W. G. Overend, A. R. Peacocke, and J. B. Smith, *J. Chem. Soc.*, 3487 (1961).(473) R. S. Tipson and H. S. Isbell, *J. Res. Nat. Bur. Stand.*, A66, 31 (1962).(474) M. Rudrum and D. F. Shaw, *J. Chem. Soc.*, 52 (1965).

of particular interest since ring-closure reactions to form six-membered rings which proceed much more rapidly than analogous reactions to form five-membered rings are only rarely found.¹⁸⁷

Galactose,^{488, 447, 475-481} talose,⁴⁴⁷ and arabinose⁴⁴⁷ also show complex mutarotations. Light is thrown on these by the nmr spectra of solutions in D₂O which for talose¹⁰⁶ and arabinose¹⁰⁶ definitely and for galactose probably (*cf.* ref 106 with ref 107 and 474) show a signal or signals attributable to the anomeric proton or protons of furanose forms (see Table XLIXA). It has also been suggested that furanose forms are

Table XLIXA

Percentage Compositions ($\pm 2\%$) of Solutions of Aldoses in D₂O at 40°^a

	Furanose		Pyranose	
	α	β	α	β
D-Allose	5	7	16	71
D-Altrose	20	13	27	40
D-Gulose		22		78
D-Talose	20	11	40	29
D-Arabinose		3	63	24
D-Ribose	6	18	20	56
3-Deoxyglucose	6	26	26	40

^a More extensive data have recently been published.^{1b}

present in pyridine solutions of galactose since trimethylsilylation of a mutarotated solution yields 12.1% trimethylsilyl tetra-*O*-(trimethylsilyl)- β -D-galactofuranoside and 5.1% of its α anomer as well as the corresponding pyranosides.⁴⁸² Attempts have been made to analyze the kinetics of these mutarotations in terms of equilibria of the type

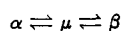

but it seems unlikely that these are correct since it would mean that with galactose, for instance, the α - and β -pyranose forms were only interconverted *via* the furanose form. The constants calculated in this way cannot therefore be related simply to the rate constants of any of the reactions that are actually taking place and clearly more complex reaction schemes are required (*cf.*, *e.g.*, ref 478).

No signals corresponding to furanose forms could be found in the nmr spectra of solutions of D-glucose, D-mannose, D-xylose, D-lyxose, and 2-deoxyglucose. It was suggested that furanose forms are favored when there are no *cis* substituents at C(3) and C(4) (compare glucose with allose and 3-deoxyglucose).¹⁰⁶

The proportions of furanose forms present at equilibrium in DMSO solutions is greater than in D₂O (Table XLIXB).^{107, 483} This proportion is also increased on methylation of the aldose

(475) C. N. Riiber and J. Minsaas, *Ber.*, 59, 2266 (1926).

(476) G. F. Smith and T. M. Mowry, *J. Chem. Soc.*, 666 (1928).

(477) T. M. Lowry and G. F. Smith, *J. Phys. Chem.*, 33, 9 (1929).

(478) C. N. Riiber, J. Minsaas, and R. T. Lyche, *J. Chem. Soc.*, 2173 (1929).

(479) F. P. Worley and J. C. Andrews, *J. Phys. Chem.*, 32, 307 (1928).

(480) N. A. Sorensen, *Kgl. Norske Videnskab. Selskabs, Skrifter*, No. 2 (1937).

(481) C. N. Riiber and N. A. Sorensen, *ibid.*, No. 22 (1937).

(482) R. S. Shallenberger and T. E. Acree, *Carbohyd. Res.*, 1, 495 (1966); T. E. Acree, R. S. Shallenberger, and L. R. Mattick, *ibid.*, 6, 498 (1968).

(483) A. S. Perlin, *Can. J. Chem.*, 44, 539 (1966).

Table XLIXB

Percentage of Furanose Forms Present at Equilibrium

	In D ₂ O	In DMSO
D-Arabinose	Trace	33
2,3-Di- <i>O</i> -methyl-D-arabinose	17	65
D-Galactose	Trace	~15
2,3-Di- <i>O</i> -methyl-D-galactose	10	38
D-Altrose	34	44
2,3-Di- <i>O</i> -methyl-D-altrose	>45	~80

in a way similar to that in which the proportion of methyl furanosides in methanol is increased on methylation (see p 414).¹⁰¹

XI. Reactions of Aldoses with Carbonyl Reagents

A. OXIME, SEMICARBAZONE, AND PHENYLHYDRAZONE FORMATION

As well as being capable of existence as true oximes, semicarbazones, and phenylhydrazones, of which *syn* and *anti* forms are possible (*e.g.*, 137 and 138), these derivatives may also exist in cyclic pyranose and furanose modifications (*e.g.*, 139-142), and although the structures of a few of them in the crystalline state are known (see, *e.g.*, ref 24, 31, 484), those of the species present in solution are not. This means that the structures of the kinetically controlled products of the reactions of aldoses with hydroxylamine, semicarbazide, and phenylhydrazine are also not known, and hence any discussion of the reaction mechanism is hampered by our not knowing for certain what the reactions are!

The first question to be asked is "do the bases attack a cyclic modification of the aldose, present in high concentration, or the aldehyde form present in low concentration?" The fact that glycosides are unreactive suggests that cyclic forms of the sugar would be unreactive also and that it is the aldehyde form which reacts (see ref 485). It also seems likely that the intermediate carbinolamines would undergo dehydration to form the true oxime, semicarbazone, or phenylhydrazone rather than an intramolecular displacement of water to yield the cyclic forms directly. The reaction may therefore be speculatively formulated as in Scheme IV.

It has been suggested, however,^{381, 486} that the formation of D-mannose phenylhydrazone involves a direct reaction between β -D-mannopyranose and phenylhydrazine. The reaction of β -D-mannopyranose-1-¹⁴C and phenylhydrazine initially shows an inverse isotope effect which decreases as the reaction proceeds, but the reaction of the mutarotated mixture of D-mannose-1-¹⁴C shows a normal isotope effect. This was explained by assuming that the reactive form of mannose is the β modification and that this undergoes a concurrent anomerization which shows a normal isotope effect. The unreacted β -D-mannopyranose and the phenylhydrazone formed from it therefore show an enrichment in ¹⁴C. A detailed kinetic investigation of this reaction would be of considerable interest to see if it supports this interpretation.

(484) (a) K. Bjåmer, S. Furberg, and C. S. Petersen, *Acta Chem. Scand.*, 18, 587 (1964); (b) *cf.* H. S. Blair and G. A. F. Roberts, *J. Chem. Soc.*, C, 2425 (1967); L. Mester and G. Vass, *Tetrahedron Lett.*, 5191 (1968).

(485) W. P. Jencks, *Progr. Phys. Org. Chem.*, 2, 84 (1967).

(486) H. Simon and D. Palm, *Chem. Ber.*, 93, 1289 (1960).

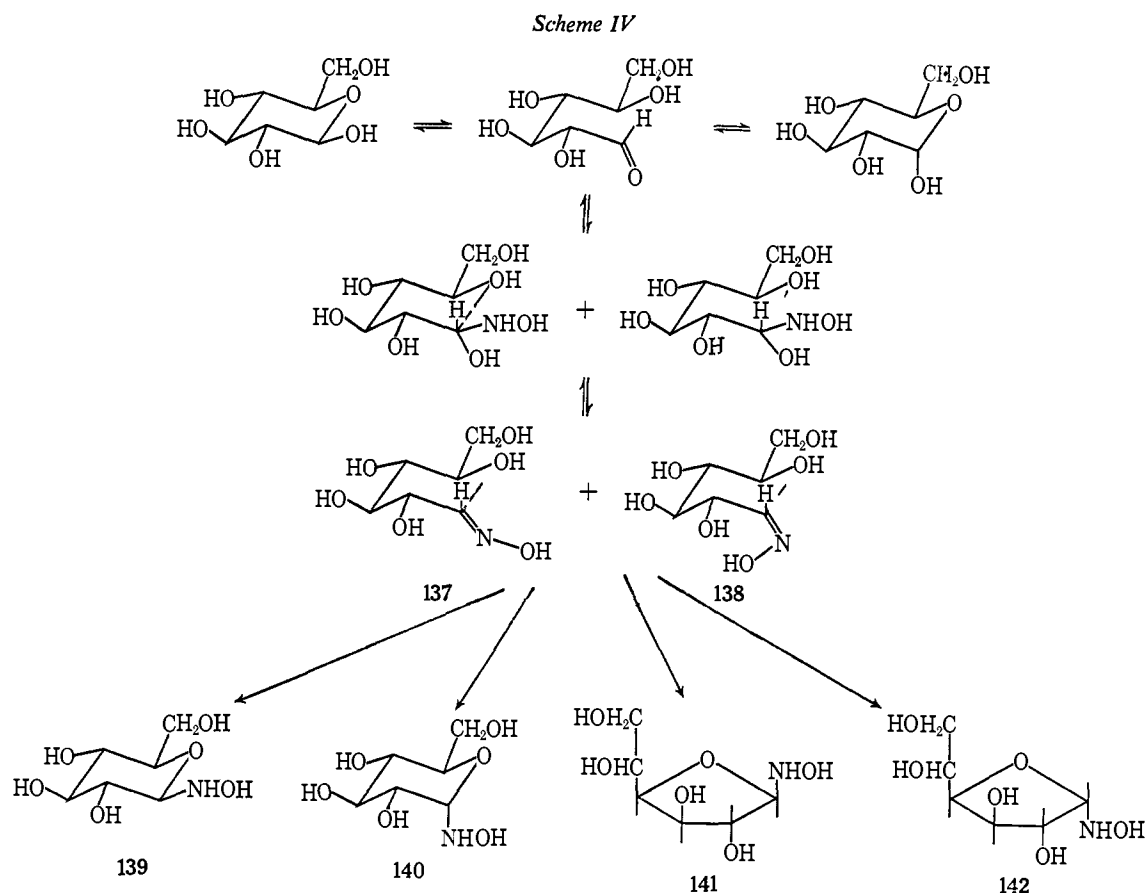

On the other hand, a kinetic investigation of the reaction of several aldoses with hydroxylamine, semicarbazide, and hydrazine has been interpreted as involving reactions of the aldehyde forms.^{487, 488} Equilibrium constants (e.g., Table L)

Table L

Equilibrium Constants, $K_{\text{over-all}}^a$ for Aldose Oxime Formation at 25°

Aldose	pH		
	2.5	3.6	4.6
Glucose	0.96	8.68	70.5
Galactose	3.46	33.3	210
Mannose	3.93	39.8	324
Xylose	5.06	51.7	403
Arabinose	5.33	50.9	411
Ribose	13.1	138	1140
Lyxose	12.0	118	1040

^a $K_{\text{over-all}} = [\text{oxime}]/[\text{sugar}][\text{NH}_2\text{OH}]$.

and rate constants (e.g., Table LI) were determined starting with the mutarotated mixtures of aldose. A detailed pH-rate profile for the formation of xylose oxime showed a maximum at pH 4-5. Rate measurements with pure anomeric forms of glucose and galactose showed that the α anomers reacted faster than the β , but as the reaction proceeded the rates be-

came equal owing to anomerization. Buffer catalysis was observed in oxime, semicarbazone, and hydrazone formation above about pH 4.6 but only with semicarbazone formation below this pH. This behavior is very similar to that found in the reactions of simple aldehydes with these reagents. The maxima in the pH-rate profiles correspond to a change in the slow step from dehydration of the carbinolamine intermediate at high pH's to nucleophilic attack by the base at low pH's, and only with semicarbazone formation is this latter step general acid catalyzed.⁴⁸⁵ The results for the aldoses were interpreted in terms of reactions similar to those shown in Scheme IV.⁴⁸⁷ Under some conditions ring opening of the aldose must be partly rate determining since the α and β forms react at different rates. The different rates of reaction of different aldoses (Table LI) are probably due to different rates of ring opening at pH's where this is partly rate determining and different standing concentrations of the aldehyde form at other pH's.

Table LI

Second-Order Rate Constants ($\text{l. mole}^{-1} \text{min}^{-1}$) for Oxime Formation 25°

Aldose	pH			
	2.5	3.6	4.6	7.0
Glucose	0.0210	0.0412	0.0430	0.078
Galactose	0.088	0.182	0.192	
Mannose	0.118	0.197	0.242	
Xylose	0.145	0.248	0.259	0.139
Arabinose	0.216	0.439	0.475	0.206
Ribose	0.327	0.601	0.679	0.347
Lyxose	0.360	0.700	0.838	0.431

(487) J. W. Haas, J. D. Storey, and C. C. Lynch, *Anal. Chem.*, **34**, 145 (1962).

(488) J. W. Haas and R. E. Kadunce, *J. Amer. Chem. Soc.*, **84**, 4910 (1962).

Pathway A

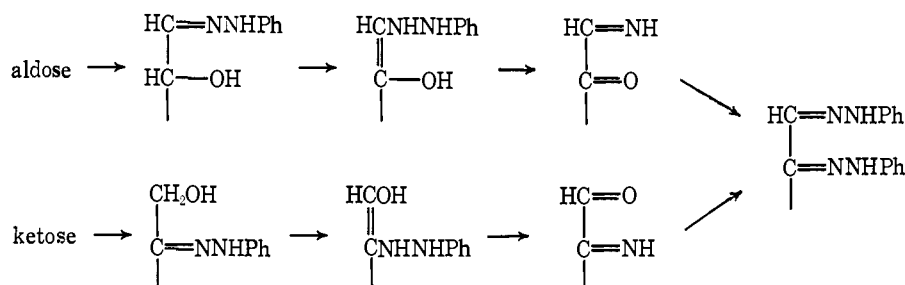

Pathway B

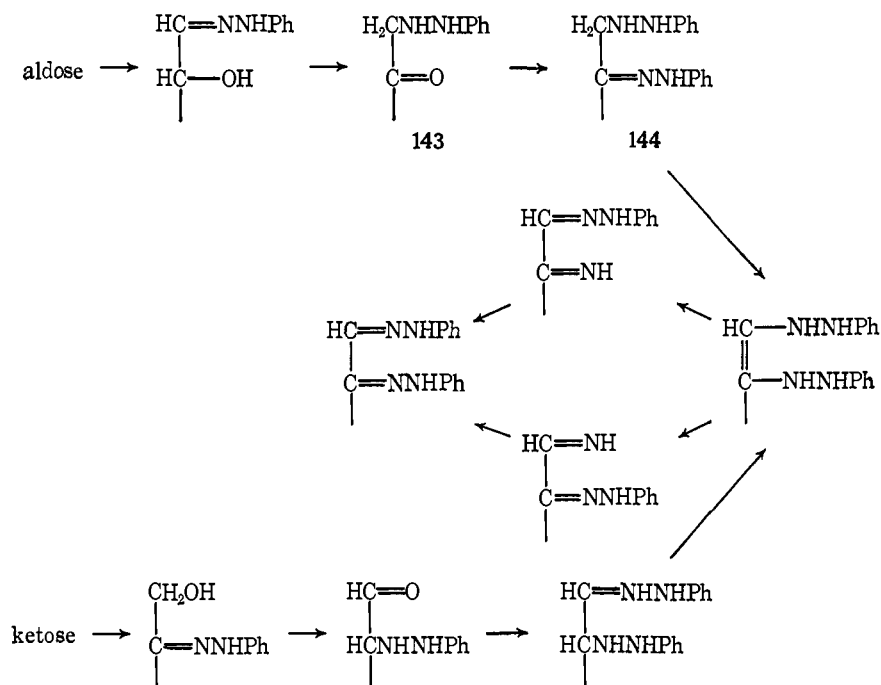

Some of these results were foreshadowed by an earlier but less complete investigation in which it was shown that the rate of reaction of phenylhydrazine with glucose, fructose, and galactose depends on the concentration of buffer⁴⁸⁹ (see also ref 490, 491). In another early investigation the interesting observation was made that whereas D-galactofuranose tetraacetate reacts almost as rapidly with phenylhydrazine as aldehydogalactose pentaacetate, D-galactopyranose tetraacetate reacts 50–60 times more slowly.⁴⁹²

Recently rate constants for the reactions of sugars with arylhydrazines have been reported to increase in the order L-sorbose < D-fructose < D-glucose < D-galactose < D-mannose < D-xylose < L-arabinose < D-ribose.⁴⁹³

B. OSAZONE FORMATION

Although much effort has gone into investigating this reaction (cf. ref 494), the structure of the intermediates through which it passes is still a subject of debate, and the question of the

structure of the transition states is one which has scarcely been broached. It is generally agreed that, as originally proposed by Weyand,⁴⁹⁵ the phenylhydrazone is formed initially and that this undergoes an Amadori-type rearrangement followed by nitrogen–nitrogen bond fission either before (pathway A) or after (pathway B) condensation with a second mole of phenylhydrazine.

In principle it should be possible to distinguish between these pathways by starting with phenylhydrazone labeled at N(2) and determining the isotopic composition of the ammonia formed in the reaction. With pathway A it should contain 100% of the label but with pathway B less than this (see eq 44 and 45).

This experiment is complicated by the intervention of hydrazone exchange which results in scrambling of the label before osazone formation takes place. Shemyakin and his coworkers overcame this difficulty by working with solutions in amyl alcohol or glacial acetic acid to suppress hydrazone exchange and by determining the isotopic composition of unreacted hydrazone and hydrazine so that when hydrazone exchange did occur it could be detected and allowed for.⁴⁹⁶ Under these conditions it was found that the reactions of labeled *p*-nitro-

(489) E. G. R. Ardagh and F. C. Rutherford, *J. Amer. Chem. Soc.*, **57**, 1085 (1935).

(490) G. H. Stempel, *ibid.*, **56**, 1351 (1934).

(491) A. Orning and G. H. Stempel, *J. Org. Chem.*, **4**, 410 (1939).

(492) J. Compton and M. L. Wolfrom, *J. Amer. Chem. Soc.*, **56**, 1157 (1934).

(493) H. H. Stroh and P. Golüke, *Z. Chem.*, **7**, 60 (1967); see also H. H. Stroh and H. Tengler, *Chem. Ber.*, **101**, 751 (1968).

(494) H. El Khadem, *Advan. Carbohydr. Chem.*, **20**, 139 (1965).

(495) F. Weyand, *Ber.*, **73**, 1284 (1940).

(496) M. M. Shemyakin, V. I. Maimind, K. M. Ermolaev, and E. M. Bamdas, *Tetrahedron*, **21**, 2771 (1965).

phenylhydrazones of benzoin and D-fructose retained respectively 98.5 and 90% of the label. As intermediate **145**

Pathway A

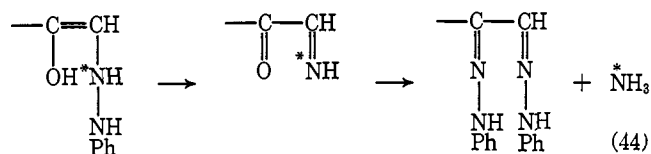

Pathway B

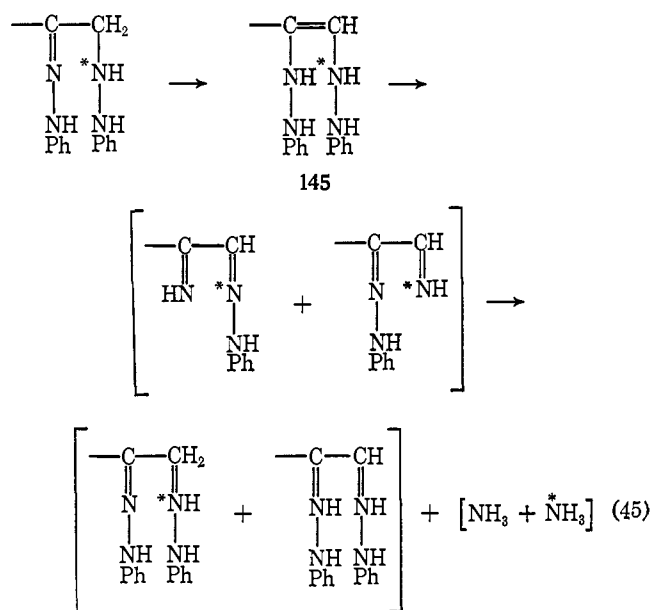

of pathway B is symmetrical with benzoin, 50% of the label should be lost if this pathway were followed, and hence the results obtained support pathway A. With fructose intermediate **145** is not symmetrical, and hence here it is possible that more than 50% of the label might be retained if pathway B were followed. A small amount of hydrazone exchange occurred, however, and when this is corrected for the amount of label retained, must be close to 100% so that pathway A is the more likely route for the formation of fructose osazone also.

Consistent with this interpretation it was found that on heating benzoin *p*-nitrophenylhydrazone in acetic acid a compound was formed which reacted rapidly with 2 moles of *p*-nitrophenylhydrazine to yield the benzil osazone. This compound was considered to be the ketimine **147** formed *via* a cyclic transition state **146**

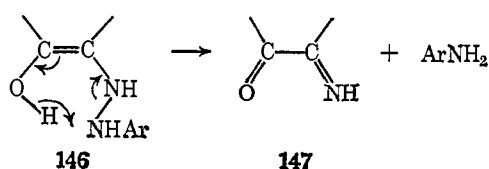

On heating cyclohexanolone *p*-nitrophenylhydrazone in glacial acetic acid containing 2 moles of acetic anhydride, the *N*-acetyl derivative of the enamine form of the corresponding ketimine (**148**) was obtained.⁴⁹⁸ All these results then support the view that under these conditions pathway A is followed.

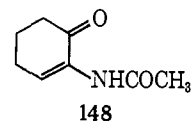

There is also the possibility that a distinction between the two pathways could be made by starting with an aldose labeled with tritium at C(1). In pathway B some of the intermediates (**143** and **144**) carry two hydrogens at C(1) and hence scrambling of the label may occur, but with pathway A this cannot happen. Interpretation is complicated, however, by the fact that isotope effects will cause protium loss to occur more rapidly than tritium loss from an intermediate bearing protium and tritium at C(1).

It was found that tritium-labeled glucose and mannose phenylhydrazones yielded osazone with loss of tritium in dilute aqueous solution but not in concentrated solution.⁴⁹⁷⁻⁴⁹⁹ In addition incorporation of tritium occurred when the unlabeled phenylhydrazones were allowed to react in tritium-labeled water.⁴⁹⁹ These results were interpreted in terms of the major part of the reaction proceeding by pathway B but with a small amount possibly proceeding *via* pathway A.

Whether these differing conclusions really are the results of the pathway followed in aqueous solution being different from that followed in amyl alcohol and acetic acid or whether one of them is wrong remains to be decided (see also ref 500).

The failure of osazone formation to proceed beyond C(2) with phenylhydrazine is not understood. It has been suggested that a stable intramolecularly hydrogen-bonded structure **149** is responsible⁵⁰¹ (see also ref 502-506). Consistent with this, when formation of such a structure is not possible as when 1-methylphenylhydrazine is used, osazone formation occurs at every carbon atom.^{507a} Intramolecularly hydrogen-bonded

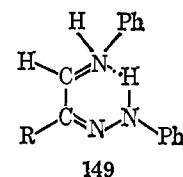

structures as **149** are frequently in equilibrium with appreciable concentrations of nonintramolecularly hydrogen-bonded structures, however, and hence this explanation cannot be correct. At present then the reason for osazone formation not occurring beyond C(2) with phenylhydrazine is unknown.^{507b}

(497) F. Friedberg and L. Kaplan, *J. Amer. Chem. Soc.*, **79**, 2600 (1957).

(498) F. Weygand, H. Simon, and J. F. Klebe, *Chem. Ber.*, **91**, 1567 (1958).

(499) H. Simon, K. D. Keil, and F. Weygand, *ibid.*, **95**, 17 (1962).

(500) A. Hassner and P. Catsoulacos, *Tetrahedron Lett.*, 489 (1967); H. Simon, G. Heubach, and H. Wacker, *Chem. Ber.*, **100**, 3106 (1967); H. Simon and W. Moldenhauer, *ibid.*, **102**, 1191, 1198 (1969).

(501) L. F. Fieser and M. Fieser, "Organic Chemistry," D. C. Heath and Co., Boston, Mass., 1944, p 352.

(502) O. L. Chapman, R. W. King, W. J. Welstead, and T. J. Murphy, *J. Amer. Chem. Soc.*, **86**, 4968 (1964).

(503) O. L. Chapman, *Tetrahedron Lett.*, 2599 (1966).

(504) (a) L. Mester, E. Moczar, and J. Parello, *J. Amer. Chem. Soc.*, **87**, 596 (1965); (b) L. Mester, E. Moczar, G. Vass, and A. Schimpl, *Carbohydr. Res.*, **5**, 406 (1967).

(505) L. Mester, *Angew. Chem. Intern. Ed. Engl.*, **4**, 574 (1965).

(506) L. Mester, E. Moczar, G. Vass, and A. Schimpl, *Tetrahedron Lett.*, 2943 (1967).

(507) (a) O. L. Chapman, W. J. Welstead, T. J. Murphy, and R. W. King, *J. Amer. Chem. Soc.*, **86**, 732 (1964); (b) *ibid.*, **89**, 7005 (1967); but see L. Mester, G. Vass, A. Stephen, and J. Parello, *Tetrahedron Lett.*, 4053 (1968).

XII. Nucleophilic Displacement, Anomerization, and Elimination Reactions of Glycosyl Halides

A. NUCLEOPHILIC DISPLACEMENTS

The kinetics of displacement reactions of *O*-acetyl- and *O*-benzoylglycosyl halides have been studied by several groups of workers.^{151, 508-514} Important mechanistic differences occur between the reactions of those compounds in which the halogeno group and the acyloxy group on carbon 2 are *cis* and those in which they are *trans*.

The first-order rate coefficients for the solvolyses in 75% (w/w) aqueous acetone of several 1,2-*cis*-*O*-acetyl glycosyl halides have been shown to increase as the reaction proceeds (see Table LII).⁵¹⁵ This effect becomes greater as the water con-

The determination of the kinetically controlled products of the solvolyses of these 1,2-*cis*-acylglycosyl halides in aqueous acetone is made difficult by their undergoing anomerization and acyl migration at rates similar to those for the solvolyses. However, analysis of the plot of optical rotation against time for the solvolysis of tetra-*O*-acetyl- α -D-glucopyranosyl and α -D-galactopyranosyl bromide in 60% (v/v) aqueous acetone indicated that the optical rotations of the initially formed products were $-30^\circ \pm 50\%$ and $+25^\circ \pm 5\%$, *i.e.*, close to those of 2,3,4,6-tetra-*O*-acetyl- β -D-glucopyranose and galactopyranose for which values of -4.2° (EtOH) and $+25^\circ$ (H₂O) have been reported. Hence these reactions probably proceed with a high degree of inversion as 2,3,4,6-tetra-*O*-acetyl- α -D-glucopyranose and α -D-galactopyranose have rotations of $+139^\circ$ and $+144^\circ$, respectively.⁵¹⁵

Table LII

The First-Order Rate Coefficients (10^6k , sec⁻¹) at 0 and 70% Reaction for 1,2-*cis*-*O*-Acetylglucopyranosyl Bromides in Aqueous Acetone

Compound	Composition of acetone								
	90% (w/w)			75% (w/w)			60% (v/v)		
	k_0	k_{70}	k_{70}/k_0	k_0	k_{70}	k_{70}/k_0	k_0	k_{70}	k_{70}/k_0
Tetra- <i>O</i> -acetyl- α -D-glucopyranosyl bromide	0.52	2.9 (22.4°)	5.6	7.2	11 (22.3°)	1.5	40.2	44.4 (20.2°)	1.1
Tetra- <i>O</i> -acetyl- α -D-galactopyranosyl bromide				19.5	30 (22.5°)	1.5	120	140 (20.9°)	1.1
Tri- <i>O</i> -acetyl- β -L-arabinopyranosyl bromide				214	278 (22.5°)	1.3			
Tri- <i>O</i> -acetyl- α -D-xylopyranosyl bromide	10	50 (12.5°)	5.0	577	825 (22.4°)	1.4			

centration of the solvent is decreased, and the initial rate constants increase rapidly with increasing water content of the solvent. The rate of solvolysis of tetra-*O*-acetyl- α -D-glucopyranosyl bromide in 60% (v/v) aqueous acetone is independent of added hydroxide ion (see Table LIII), and the rate is increased about 20% by the addition of 0.05 *M* sodium bromide. Such behavior is characteristic of those SN1 solvolyses in which halide ions do not compete very successfully with the solvent for the carbonium ions. This preference for an SN1 mechanism is readily rationalized as arising from stabilization of the intermediate carbonium ion and the transition state for its formation by mesomeric release from the ring oxygen similar to that postulated to occur in glycoside hydrolysis (see section II.A.2). It has been shown that in a series of acyclic α -chloro ethers a similarly located oxygen atom results in a rate increase of 10^{14} for reactions involving an SN1 mechanism but only 10^6 for reactions involving an SN2 mechanism.^{516, 517}

Table LIII

First-Order Rate Constants for the Solvolysis of Tetra-*O*-acetyl- α -D-glucopyranosyl Bromide^a

[NaOH], <i>M</i>	10^6k , sec ⁻¹
0	5.09
0.025	5.03
0.075	5.03

^a ~ 0.05 *M* in 60% (v/v) aqueous acetone at 21.2°.⁵⁰⁸

A detailed investigation of the products of the alcoholyses of tetra-*O*-acetyl- α -D-glucopyranosyl bromide has shown that in methanol the reaction proceeds with 100% inversion, but in ethanol, 1-propanol, and 1-butanol there is appreciable (4-11%) retention, the proportion of which increases with increasing chain length of the alcohol.⁵¹⁸ Addition of lithium or ammonium bromide but not of lithium or sodium perchlorate causes an increase in the amount of retention probably through formation of the β -bromide (eq 46). It would be interesting if support for this hypothesis could be obtained by showing independently that the β -bromide reacted with inversion of configuration as the β -chloride does on methanolysis despite the presence of the neighboring acetoxyl group.⁵¹² It would also be interesting to know if this latter reaction proceeded *via* an ortho ester (*cf.* ref 519).

(518) L. R. Schroeder, J. W. Green, and D. C. Johnson, *J. Chem. Soc., B*, 447 (1966).

(508) F. H. Newth and G. O. Phillips, *J. Chem. Soc.*, 2896 (1953).

(509) F. H. Newth and G. O. Phillips, *ibid.*, 2900 (1953).

(510) F. H. Newth and G. O. Phillips, *ibid.*, 2904 (1953).

(511) G. L. Mattock and G. O. Phillips, *ibid.*, 1836 (1956).

(512) G. L. Mattock and G. O. Phillips, *ibid.*, 268 (1957).

(513) G. L. Mattock and G. O. Phillips, *ibid.*, 130 (1958).

(514) R. U. Lemieux and G. Huber, *Can. J. Chem.*, 33, 128 (1955).

(515) B. Capon, P. M. Collins, A. A. Levy, and W. G. Overend, *J. Chem. Soc.*, 3242 (1964).

(516) P. Ballinger, P. B. D. de la Mare, G. Kohnstam, and B. M. Prestt, *ibid.*, 3641 (1955).

(517) T. C. Jones and E. R. Thornton, *J. Amer. Chem. Soc.*, 89, 4863 (1967).

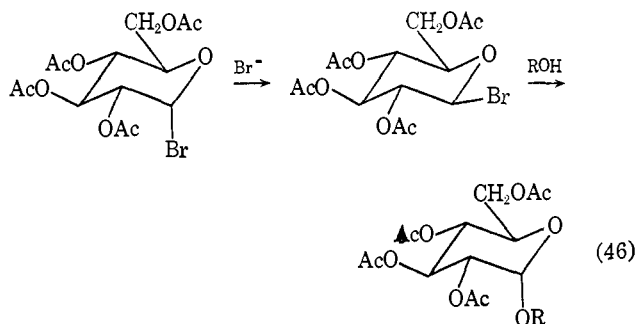

The entropies of activation of these alcoholyses are all similar (-16 to -18 eu) suggesting that they proceed by a similar, most probably S_N1 , mechanism. The 100% inversion found in the methanolysis must then be the result of the initially formed (α) ion pair being captured before dissociation to free ions or rearrangement to a β ion pair can occur. Presumably the important factor here is the decrease in nucleophilicity of the solvent with increasing chain length as a result of a decrease in the proportion of hydroxyl groups and possibly also due to a steric effect; capture of the α ion pair thus occurs more readily the fewer the number of carbon atoms in the alcohol.

The entropy of activation for the alcoholysis of tetra-*O*-acetyl- α -D-glucopyranosyl bromide in 2-propanol is about 30 eu more negative than for the primary alcoholyses.⁵¹⁸ This suggests a change to an S_N2 mechanism. The proportion of α - and β -glycosides formed in the alcoholysis in 2-propanol and cyclohexanol depends on the extent of reaction, but extrapolation to zero reaction indicates 100% inversion consistent with this mechanism. The increase in the amount of retention of configuration with percentage reaction was attributed to formation of β -bromide from an S_N2 reaction of the α -bromide and the HBr formed in the reaction. Also consistent with an S_N2 mechanism was the observation that, unlike the primary alcoholyses, addition of lithium bromide caused a large increase in the rate of the reaction in 2-propanol, presumably as a result of conversion of the α - to the more reactive β -bromide.

The methanolyses of tetra-*O*-benzoyl- α -D-glucopyranosyl bromide and of tri-*O*-benzoyl- β -L-arabinopyranosyl- α -D-xylopyranosyl and α -D-ribofuranosyl bromides have also been shown to occur with mainly inversion of configuration.⁵²⁰⁻⁵²²

In contrast to the solvolyses of 1,2-*cis*-*O*-acetylglycosyl halides, the solvolyses of four 1,2-*trans*-*O*-acetylglycosyl halides, tetra-*O*- α -D-mannopyranosyl bromide, tri-*O*-acetyl- α -L-rhamnopyranosyl and β -D-ribofuranosyl bromides, and tetra-*O*-acetyl- β -D-glucopyranosyl chloride, in 75% (w/w) aqueous acetone all yielded steady rate coefficients from the integrated first-order expression.⁵¹⁵ Addition of sodium bromide to a concentration of 0.08 *M* had no measurable effect on the rate of solvolysis of tetra-*O*-acetyl- α -L-rhamnopyranosyl bromide,⁵¹⁵ and the rate of solvolysis of the β -D-glucopyranosyl chloride (*m* value = 0.5) is less sensitive to water content of the solvent than that of its α anomer (*m* value = 0.7).⁵¹² All these observations show that the effect of variation in the solvent polarity and solvating power on

solvolysis rate is much less for the 1,2-*trans*-halides than for the 1,2-*cis*-halides and is consistent with the 1,2-*trans*-halides undergoing solvolysis with neighboring group participation by the acetoxyl group at C(2). In the transition state **150**,⁵¹⁶ the charge is more dispersed than in transition state **151** for a reaction not involving participation, and hence the rate should

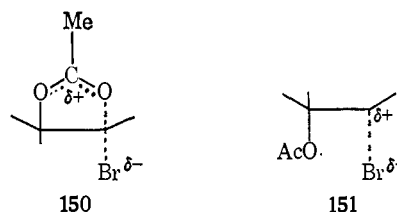

vary much less with solvent polarity and solvating power.

The ratios of the rate of solvolysis in 75% aqueous acetone and in methanol of the 1,2-*trans*-halides to those of the corresponding 1,2-*cis*-halides vary from 20 ($\delta\Delta G^\ddagger \approx 2$ kcal mole⁻¹) for the α -L-rhamnosyl-6-deoxy- α -D-glucosyl pair at 22° to 100,000 ($\delta\Delta G^\ddagger = 5$ kcal mole⁻¹) for the β -D-glucosyl- α -D-glucosyl pair at 31.9°.⁵¹⁵ This should be compared with a rate ratio of about 660 ($\delta\Delta G^\ddagger \approx 4$ kcal mole⁻¹) for the acetolyses of the *trans*- and *cis*-cyclohexyl toluene-*p*-sulfonates at 99.7°.⁵²³ Less anchimeric assistance might be expected in the solvolyses of the 1,2-*trans*-acetylglycosyl halides listed in Table LIV since a more nucleophilic solvent is used and since the glycosyl cation is already stabilized by conjugation with the ring oxygen atom, and so any additional stabilization by the acetoxyl group at C(2) should be smaller. The very large rate difference between the α - and β -glucosyl chlorides does not appear therefore to be wholly ascribable to anchimeric assistance by the *trans*-acetoxyl group in the solvolysis of the latter, and undoubtedly a large part of it results from the initial-state free energy of the α anomer. High yields (90% of the theoretical) of tetra-*O*-acetyl- α -D-glucopyranosyl chloride and related α -chlorides have been isolated from the anomerization of the corresponding β -chlorides,^{524,525} and Lemieux and Hayami have shown that the equilibrium mixture of the tetra-*O*-acetyl-D-glucopyranosyl chlorides in acetonitrile contains approximately 94% of the α anomer.⁵² Hence at least 1.5–2 kcal mole⁻¹ of the 5-kcal mole⁻¹ difference in the free energy of activation is attributable to the difference in free energies of the initial states. This is supported by the observation that the acetolysis of 3,4,6-tri-*O*-acetyl- β -D-glucosyl chloride proceeds about 100 times faster than that of its α anomer.⁵¹⁴ Thus despite the fact that these compounds do not have strongly participating group at C(2), there is nevertheless a large rate difference which probably results from the higher initial-state free energy of the β anomer.^{526a}

Analysis of the change in optical rotation during the solvolysis in 70% aqueous acetone of the α -D-mannosyl bromide, the α -L-rhamnosyl bromide, and the β -D-glucosyl chloride indicated the absence of appreciable quantities of products with retained configurations.⁵¹⁵ This suggests that the initially formed acetoxonium ion, **152**, reacts with water to form an ortho acid **153**,^{526b,527} which then undergoes ring

(519) R. U. Lemieux and A. R. Morgan, *J. Amer. Chem. Soc.*, **85**, 1889 (1963).

(520) H. G. Fletcher, C. S. Hudson, and R. K. Ness, *ibid.*, **72**, 2200 (1950).

(521) H. G. Fletcher and C. S. Hudson, *ibid.*, **72**, 4173 (1950).

(522) H. G. Fletcher, C. S. Hudson, and R. K. Ness, *ibid.*, **73**, 959 (1951).

(523) S. Winstein, E. Grunwald, R. E. Buckles, and C. Hanson, *ibid.*, **70**, 816 (1948).

(524) W. Korytnyk and J. A. Mills, *J. Chem. Soc.*, 636 (1959).

(525) R. U. Lemieux, *Advan. Carbohydr. Chem.*, **9**, 1 (1954).

(526) (a) See also T. Ishikawa and H. G. Fletcher, *J. Org. Chem.*, **34**, 563 (1969); (b) H. L. Frush and H. S. Isbell, *J. Res. Nat. Bur. Stand.*, **43**, 161 (1949).

(527) S. Winstein, C. Hanson, and E. Grunwald, *J. Amer. Chem. Soc.*, **70**, 812 (1948).

Table LIV
Comparison of the Solvolysis of 1,2-*cis*- and *trans*-Acetylglycosyl Halides in 75% (w/w) Aqueous Acetone

<i>cis</i>	Temp, °C	10 ³ <i>k</i>	E _a , kcal mole ⁻¹	Log A	<i>trans</i>	10 ³ <i>k</i>	E _a , kcal mole ⁻¹	Log A	δΔG [‡] , kcal mole ⁻¹
Tetra- <i>O</i> -acetyl-α-D-glucopyranosyl bromide	22.0	0.66	20.3	9.9	Tetra- <i>O</i> -acetyl-α-D-mannopyranosyl bromide	39.4	20.4	11.7	2.4
Tri- <i>O</i> -acetyl-β-L-arabinopyranosyl bromide	-18.3	0.16	18.6	10.1	Tri- <i>O</i> -acetyl-β-D-ribosepyranosyl bromide	34.4	2.7
Tri- <i>O</i> -acetyl-6-deoxy-α-D-glucopyranosyl	22.0	6.68	Tri- <i>O</i> -acetyl-α-L-rhamnopyranosyl bromide	149	20.2	12.1	1.7
Tetra- <i>O</i> -acetyl-α-D-glucopyranosyl chloride	31.9	0.0254	Tetra- <i>O</i> -acetyl-β-D-glucopyranosyl chloride	240	5.5

opening to yield products with inverted configuration, 154, or with a migrated acetoxy group, 155.

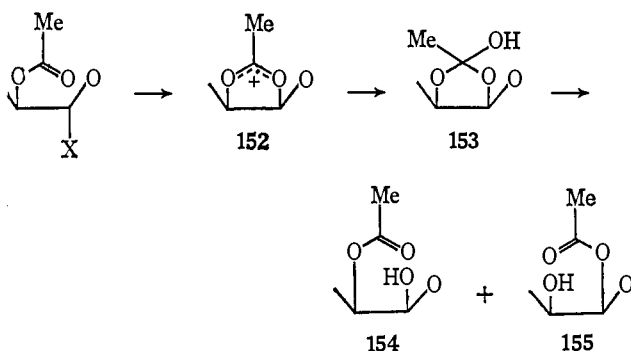

Products with retained configurations are obtained, however, in the methanolyse of tetra-*O*-benzoyl-D-mannopyranosyl bromide and of tri-*O*-benzoyl-β-D-ribosepyranosyl and -α-L-rhamnopyranosyl bromides.^{520, 522, 528}

The effects of configurational and structural changes on the rates of solvolysis of some 1,2-*cis*-*O*-acetylglycopyranosyl halides are given in Table LV, and can be explained generally in terms of secondary steric effects on the movement toward a

Table LV

First-Order Rate Constants for the Solvolyses of 1,2-*cis*-Acetylglycosyl Halides in 75% (w/w) Aqueous Acetone⁵¹⁵

	Temp, °C	10 ³ <i>k</i> , ^a sec ⁻¹
Tetra- <i>O</i> -acetyl-α-D-glucopyranosyl bromide	22.4	0.72
Tri- <i>O</i> -acetyl-6-deoxy-α-D-glucopyranosyl bromide	22.0	6.68
Tri- <i>O</i> -acetyl-6-deoxy-6-iodo-α-D-glucopyranosyl bromide	42.0	1.58
Tetra- <i>O</i> -acetyl-α-D-galactopyranosyl bromide	22.4	1.95
Tri- <i>O</i> -acetyl-α-D-xylopyranosyl bromide	22.4	57.7
Tri- <i>O</i> -acetyl-β-L-arabinopyranosyl bromide	22.5	21.4

^a Extrapolated to zero time.

half-chair conformation in the transition state, in a similar fashion to that given for glycoside hydrolysis.

The other interesting structural variation which has been investigated is replacement of the ring oxygen by sulfur which causes a decrease in rate. Thus tri-*O*-acetyl-α-D-xylothiapyranosyl bromide undergoes methanolysis about 40 times slower than tri-*O*-acetyl-α-D-xylopyranosyl bromide.⁵²⁹ This behavior is similar to that found with α-halogenoalkyl sulfides which undergo solvolysis more slowly than the corresponding α-chloro ethers^{509, 530} and is explicable as resulting from the poorer mesomeric electron-releasing properties of sulfur compared to oxygen.

In order to avoid the complications introduced by having a strongly participating group on carbon 2, Rhind-Tutt and Vernon studied the methanolysis of tetra-*O*-methyl-α-D-glucopyranosyl and mannopyranosyl chlorides.^{348a} Since addition of sodium methoxide did not produce large increases in rate (see Table LVI), they concluded that the mechanism is S_N1. The glucosyl chloride yielded 94% of methyl tetra-*O*-methyl-β-D-glucopyranoside (analysis by ir spectroscopy),

Table LVI

Effect of Sodium Methoxide on the Rate of Methanolysis of Tetra-*O*-methyl-α-D-gluco- and -mannopyranosyl Chlorides at 25°

Electrolyte	Concn, M	10 ³ <i>k</i> , min ⁻¹
Tetra- <i>O</i> -methyl-α-D-glucopyranosyl Chloride		
...	...	3.58
NaOMe	0.040	4.00
NaOMe	0.094	4.30
NaOMe	0.310	6.04
NaOMe	0.492	7.36
LiClO ₄	0.357	5.00
Tetra- <i>O</i> -methyl-α-D-mannopyranosyl Chloride		
...	...	4.00
NaOMe	0.231	4.00
NaOMe	0.658	3.34
NaOMe	1.040	2.60
LiClO ₄	0.438	6.96

(528) R. K. Ness, H. G. Fletcher, and C. S. Hudson, *J. Amer. Chem. Soc.*, 73, 296 (1951).

(529) R. L. Whistler and T. Van Es, *J. Org. Chem.*, 28, 2303 (1963).

(530) H. Böhme, H. Fischer, and R. Frank, *Ann. Chem.*, 563, 54 (1949).

i.e., the reaction proceeded with predominant inversion, but the mannosyl chloride gave only 58% of the inverted product. It was suggested that most of the products from the glucosyl chlorides were being formed from a specifically oriented ion pair (eq 47) in which attack from the α side is prevented by the chloride counterion. With the mannosyl chloride, however, it was considered that the rate of attack of methanol on the ion pair is reduced by the steric effect of the axial or *quasi*-axial methoxyl group at C(2) so that much more of the product was formed from free ions in which approach from the α side is possible (eq 48).^{526a}

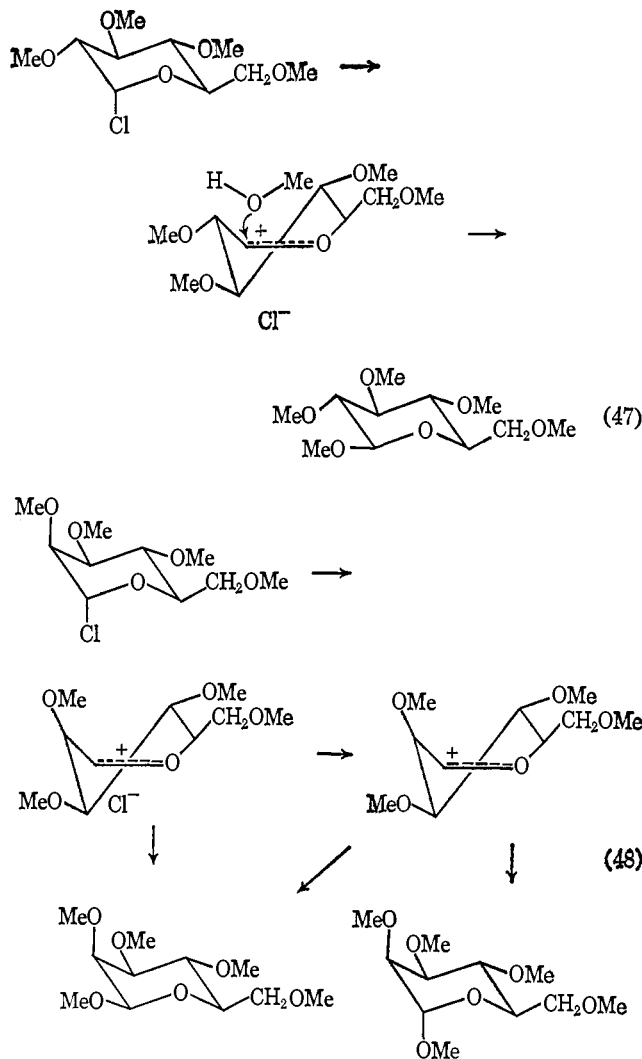

Steric hindrance to a direct nucleophilic attack on the mannosyl chloride was also observed. Whereas the glucosyl chloride underwent a ready reaction with lithium thiophenoxide in 1-propanol which showed second-order kinetics and yielded *S*-phenyl-2,3,4,6-tetra-*O*-methyl- β -D-thioglucopyranoside, the mannosyl chloride did not react. Previously Chapman and Laird had observed that tetra-*O*-acetyl- α -D-mannopyranosyl bromide did not undergo a bimolecular displacement reaction with piperidine in acetone, whereas the corresponding glucosyl bromide did,¹⁵¹ and more recently it has been shown that this compound did not react with lithium thiophenoxide in 1-pentanol-toluene (19:1 v/v).⁵¹⁵ The activities of several 1,2-*cis*-*O*-acetylglucosyl halides with this last reagent are shown in Table LVII. These reactions follow

Table LVII

Reactions of *O*-Acetylglucosyl Bromides with Lithium Thiophenoxide in 1-Pentanol-Toluene Mixtures (19:1 v/v) in 22.0^o16

	$10^3 k_2$, <i>l. mole</i> ⁻¹ <i>sec</i> ⁻¹
Tetra- <i>O</i> -acetyl- α -D-glucopyranosyl bromide	4
Tri- <i>O</i> -acetyl-6-deoxy- α -D-glucopyranosyl bromide	17
Tri- <i>O</i> -acetyl-6-deoxy-6-iodo- α -D-glucopyranosyl bromide	3
Tetra- <i>O</i> -acetyl- α -D-galactopyranosyl bromide	8
Tri- <i>O</i> -acetyl- α -D-xylopyranosyl bromide	50
Tri- <i>O</i> -acetyl- α -L-arabinopyranosyl bromide	14

second-order kinetics, but the relative reactivities are very similar to those shown in SN2 reactions. The possibility should therefore be borne in mind that these reactions do not involve a concerted SN2 process but rather an attack by the thiophenoxide ion on a reversibly formed ion pair in the manner envisaged by Snee and his coworkers.^{531,532}

In view of the suggestion^{117, 185} that the solvolysis of glycofuranosides may proceed by an A2 mechanism (see section III.A.1), it would be of considerable interest to know if solvolyses of glycofuranosyl halides were bimolecular, but so far there has been only one mechanistic investigation of these reactions.^{533,534} Compounds with an *O*-nitro- or *O*-benzyl group in the 2 position were studied to avoid the complication of neighboring group participation. The solvolysis of the 1,2-*trans*-arabinofuranosyl halides **156** and **157** in mixtures of methanol (16.7% v/v) with methylene chloride and acetonitrile

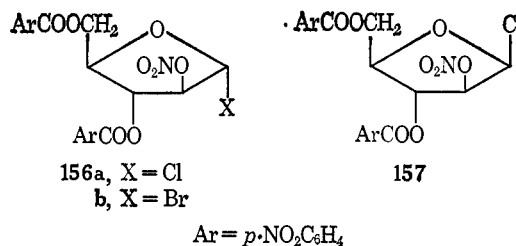

yielded a product which was almost wholly (93–97%) that of inversion of configuration. The calculated first-order constants decrease with percentage reaction, a result which was attributed to a common ion effect, the mechanism being SN1. Addition of tetrabutylammonium bromide in the solvolyses of **156b** caused a small rate decrease and eliminated the drift in rate constant; this was also attributed to a common-ion effect. It is difficult to assess the soundness of this interpretation since the effects of salts with noncommon ions were not studied, but the behavior is quite different from that observed in the methanolysis of tetra-*O*-methyl- α -D-glucopyranosyl chloride in pure methanol which is also thought to proceed by an SN1 mechanism³⁴⁸ (see section XII.A). Here steady first-order rate constants were obtained, and the rate was increased on addition of a salt with a common ion. Whether this difference results from the change in solvent, an increased sensitivity to the common ion effect, or a decreased sensitivity

(531) H. Weiner and R. A. Snee, *J. Amer. Chem. Soc.*, **87**, 292 (1965).

(532) R. A. Snee and J. W. Larsen, *ibid.*, **88**, 2593 (1966); **91**, 362 (1969).

(533) C. P. J. Glaudemans and H. G. Fletcher, *ibid.*, **87**, 2456 (1965).

(534) C. P. J. Glaudemans and H. G. Fletcher, *ibid.*, **87**, 4636 (1965).

to a noncommon ion salt effect in the reaction of the furanosyl compound, or to a difference in mechanism is difficult to say, however. It is also difficult to decide if the small amount of product of retention of configuration is indicative of an S_N1 mechanism or if it is formed from a small amount of β -halide present either in the starting material or formed in a concurrent anomerization. The entropy of activation for the solvolysis of **156b** in 1,2-dichloroethane containing methanol (16.7% v/v) is -23 eu which is probably consistent with an S_N1 or S_N2 mechanism. The effect of sodium methoxide on the rates of these reactions was not determined.

The effects of varying the substituents at C(3) and C(5) were determined by investigation of the reactivities of compounds **158**, **159**, and **160**, which have the rate constants shown (min^{-1}), on methanolysis in dichloromethane containing methanol ($\sim 10\%$) at 20° . The rate-decreasing effect of replacing benzyl by *p*-nitrobenzoyl was interpreted as an electronic effect relayed through the ring oxygen.

The solvolysis of the 1,2-*cis*- β -halide **157** was more complex than those of the 1,2-*trans*-halides with the plot of optical rotation against time showing a maximum; the product was a 39:61 mixture of the α - and β -glucosides. It was suggested

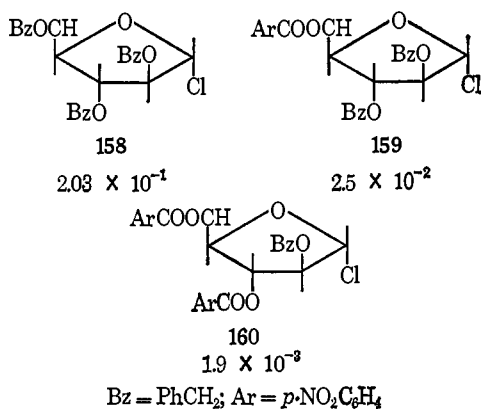

that this resulted from **157** undergoing concurrent solvolysis and anomerization to the more stable *trans*-halide **156a**.

B. ANOMERIZATION

Although tetra-*O*-acetyl- β -D-glucopyranosyl chloride has been observed to undergo mutarotation in solvents which have not been specially dried,^{535,536} this is almost certainly the result of hydrolysis, not anomerization, since it is accompanied by liberation of acid and its rate considerably reduced by drying the solvent.^{524,537} Tetra-*O*-acetyl- β -D-glucopyranosyl chloride does, however, undergo anomerization (eq 49) in acetonitrile solution in the presence of tetraethylammonium chloride, and isotope dilution analysis of the equilibrium mixture showed that it contained 93–95% of the α anomer.⁵²

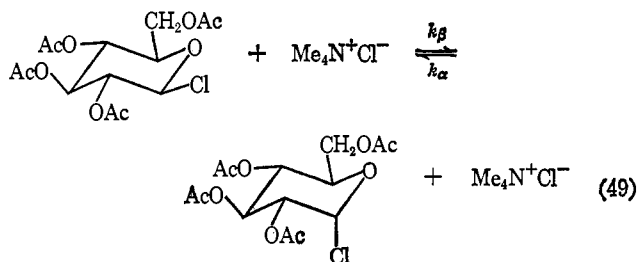

The first-order rate constants ($k_\alpha + k_\beta$), obtained polarimetrically, were proportional to the concentration of tetraethylammonium chloride (Table LVIII). The rate of ex-

Table LVIII

First-Order Rate Constants for the Anomerization of Tetra-*O*-acetyl- β -D-glucopyranosyl Chloride (0.2 M) in Acetonitrile at 30°

Concn of added tetraethylammonium salt		$10^3(k_\alpha + k_\beta)$, min^{-1}
Chloride	Perchlorate	
0.2	0	3.9
0.2	0.1	3.9
0.2	0.2	3.9
0.4	0	7.8
0.6	0	10.6

change of the α -glucosyl chloride with labeled chloride ion ($k = 2.0 \times 10^{-4} \text{ min}^{-1}$) is within experimental error equal to its rate of anomerization ($k_\alpha = 2.3 \pm 0.4 \times 10^{-4} \text{ min}^{-1}$; [glucosyl chloride] = [tetraethylammonium chloride] = 0.2 M, 30°) suggesting an S_N2 process (eq 50). If this is correct then by the principle of microscopic reversibility the reverse

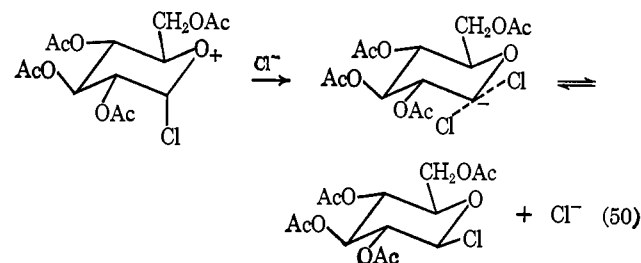

reaction, the anomerization of the β -glucosyl chloride, must also be an S_N2 process and proceed *via* the same transition state. The rate of exchange of the β -glucosyl chloride with radioactive chloride ion is, however, about four times greater than its rate of anomerization. This indicates that it is an assisted ionization (eq 51) to give an acetoxonium ion which reacts with chloride ions to give unrearranged β -chloride.

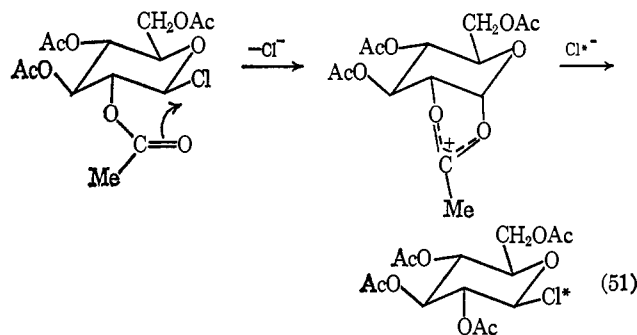

Lemieux and Hayami regard the reaction of the α -glucosyl chloride with tetraethylammonium chloride as an ionization with the attacking chloride ion providing stabilization through formation of an ion triplet.⁵² To say that the bonding in an S_N2 transition state is wholly electrostatic rather than partially covalent seems to reviewer, however, much too subtle a distinction to draw from the available evidence in the present state of the theory of substitution reactions.

(535) H. H. Schlubach, P. Stadler, and I. Wolf, *Ber.*, **61**, 287 (1928).]

(536) G. L. Mattock and G. O. Phillips, *J. Chem. Soc.*, 2244 (1959).

(537) B. Capon, *Chem. Ind.* (London), 689 (1960).

The anomerization of 3,4,6-tri-*O*-acetyl- β -D-glucosyl chloride was also studied. The polarimetric rate constant was found to be about 10^3 times greater than that for tetra-*O*-acetyl- β -D-glucopyranosyl chloride, but the position of equilibrium and the rate of chloride exchange were not determined.

Another interesting anomerization apparently occurs concurrently with the solvolysis of 2,3,4,6-tetra-*O*-methyl- α -D-galactopyranosyl chloride in 1-propanol (footnote on p 4641 of ref 348a), but details have not been published.

C. ELIMINATION REACTIONS

Acetylglycosyl halides on treatment with nitrogen bases show a quite strong tendency to undergo elimination reactions to yield 2-acetoxyglycols.¹⁵¹ The kinetics of the dehydrobromination of tetra-*O*-acetyl- α -D-glucopyranosyl bromide by a large number of amines in acetonitrile solution have been measured by Lemieux and Lineback.⁵³⁸ Some of whose results are given in Table LIX.

Table LIX

Reaction of Tetra-*O*-acetyl- α -D-glucopyranosyl Bromide (0.05 *M*) with Amines (0.4 *M*) in Acetonitrile Containing Tetra-*n*-butylammonium Bromide (0.25 *M*) at 25°

Amine	k , min^{-1}	Product, %	
		2-Acetoxy- glucal	<i>N</i> - Glucoside
Pyrrolidine	0.3	90	...
1,4-Diaza[2.2.2]- bicyclooctane	0.17	90	...
Piperidine	0.14	90	...
Morpholine	0.041	40	50
Diethylamine	0.036	90	...

Although diethylamine is a very effective catalyst in this reaction, it has virtually no effect on the rate of elimination of cyclohexyl bromide under similar conditions. Presumably the reaction of the glycosyl halide is an "E1-like E2" reaction for which it is known that the relative effectiveness of basic catalysts differ from that found with reactions proceeding *via* a "centre E2" mechanism.⁵³⁹

It is difficult to assess the suggestion⁵³⁸ that the amine helps stabilize the developing carbonium ion in a mechanism similar to the "merged mechanism" of Winstein, Darwish, and Holness.⁵⁴⁰ It should be noted, however, that the "merged mechanism" has been strongly criticized in recent years.^{539, 541-542}

XIII. Anomerization and Dissociation of Aldose Acetates

When aldose acetates are dissolved in acetic acid or in acetic acid-acetic anhydride mixtures containing sulfuric acid or perchloric acid, they undergo anomerization. The early work of Bonner⁵⁴³ and Painter⁵⁴⁴ showed that the rate of anomerization

of the glucose pentaacetates increased with increasing strong acid concentration and with increasing acetic anhydride concentration, and that the equilibrium mixture contained 87% of the α anomer. The reaction mechanism was investigated in more detail by Lemieux, Brice, and Huber⁵⁴⁵ and by Bonner⁵⁴⁶ who measured the rate of anomerization and the rate of acetate exchange by using compounds in which the acetoxy group at C(1) was labeled with ^{14}C (Table LX). The rates of acetate

Table LX

First-Order Rate Constants for Acetate Exchange and Anomerization in 1:1 Acetic Acid-Acetic Anhydride Containing Sulfuric Acid (0.50 *M*) at 25°^{545, 546}

Compound	$10^4 k_{\text{exch}}$, sec^{-1}	$10^4 k_{\text{anom}}$, sec^{-1}
Penta- <i>O</i> -acetyl- α -D-glucopyranose	0.703	0.68
Penta- <i>O</i> -acetyl- β -D-glucopyranose	72.2	4.93
Penta- <i>O</i> -acetyl- α -D-mannopyranose	3.15	0.33
Penta- <i>O</i> -acetyl- β -D-mannopyranose	5.55	5.23
1,3,4,6-Tetra- <i>O</i> -acetyl-2- <i>O</i> -mono- chloroacetyl- α -D-glucose	0.31	0.27
1,3,4,6-Tetra- <i>O</i> -acetyl 1-2- <i>O</i> -mono- chloroacetyl- β -D-glucose	8.3	1.7
1,3,4,6-Tetra- <i>O</i> -acetyl-2- <i>O</i> -dichloro- acetyl- α -D-glucose	...	0.042
1,3,4,6-Tetra- <i>O</i> -acetyl-2- <i>O</i> -dichloro- acetyl- β -D-glucose	0.77	0.345
1,3,4,6-Tetra- <i>O</i> -acetyl-2- <i>O</i> -trichloro- acetyl- α -D-glucose	0.018	0.020
1,3,4,6-Tetra- <i>O</i> -acetyl-2- <i>O</i> -trichloro- acetyl- β -D-glucose	0.20	0.125

exchange and anomerization were almost identical for penta-*O*-acetyl- α -D-glucopyranose (161), but the rate of exchange of the β anomer, 162, was 14.6 times greater than the rate of anomerization. Since the anomerization reaction is an equilibrium, the principle of microscopic reversibility⁵⁴⁷ must apply, and the mechanism of the $\beta \rightarrow \alpha$ conversion must be the exact reverse of the $\alpha \rightarrow \beta$ conversion.⁵⁴⁸ Since the reaction is acid catalyzed, the $\alpha \rightarrow \beta$ conversion presumably involves a nucleophilic displacement by acetic acid on the conjugate acid of the α -pentaacetate. This is written as a unimolecular process in eq 52, but it is uncertain if this is correct. The anomerization of the 2-deoxyglucose tetraacetates is certainly unimolecular since the rate of exchange of the β isomer is about twice the rate of anomerization (Table LXI), indicating the intervention of a carbonium ion which has about an equal chance of forming α - or β -tetraacetate.⁵⁴⁹ The introduction of an acetoxy group at C(2) would be expected to increase the bimolecular character of the transition state, and the fact that the rates of exchange and anomerization of penta-*O*-acetyl- α -D-glucopyranose are equal suggests that this may be so, but the application of other mechanistic criteria to this reaction is

(538) R. U. Lemieux and D. R. Lineback, *Can. J. Chem.*, **43**, 94 (1965).

(539) J. F. Bunnett, *Angew. Chem. Intern. Ed. Engl.*, **1**, 225 (1962); J. F. Bunnett and E. Bacciocchi, *J. Org. Chem.*, **32**, 11 (1967).

(540) S. Winstein, D. Darwish, and N. J. Holness, *J. Amer. Chem. Soc.*, **78**, 2915 (1956).

(541) D. J. McLennan, *J. Chem. Soc., B*, 705 (1966).

(542) D. V. Banthorpe in "Studies on Chemical Structure and Reactivity," J. H. Ridd, Ed., Methuen, London, 1966, p 33.

(543) W. A. Bonner, *J. Amer. Chem. Soc.*, **73**, 2659 (1951).

(544) E. P. Painter, *ibid.*, **75**, 1137 (1953).

(545) R. U. Lemieux, C. Brice, and G. Huber, *Can. J. Chem.*, **33**, 134 (1955).

(546) W. A. Bonner, *J. Amer. Chem. Soc.*, **81**, 5171 (1959).

(547) A. A. Frost and R. G. Pearson, "Kinetics and Mechanism," John Wiley and Sons, Inc., New York, N. Y., 1961, p 211.

(548) B. Capon and W. G. Overend, *Advan. Carbohyd. Chem.*, **15**, 42 (1960).

(549) W. A. Bonner, *J. Amer. Chem. Soc.*, **83**, 962 (1961).

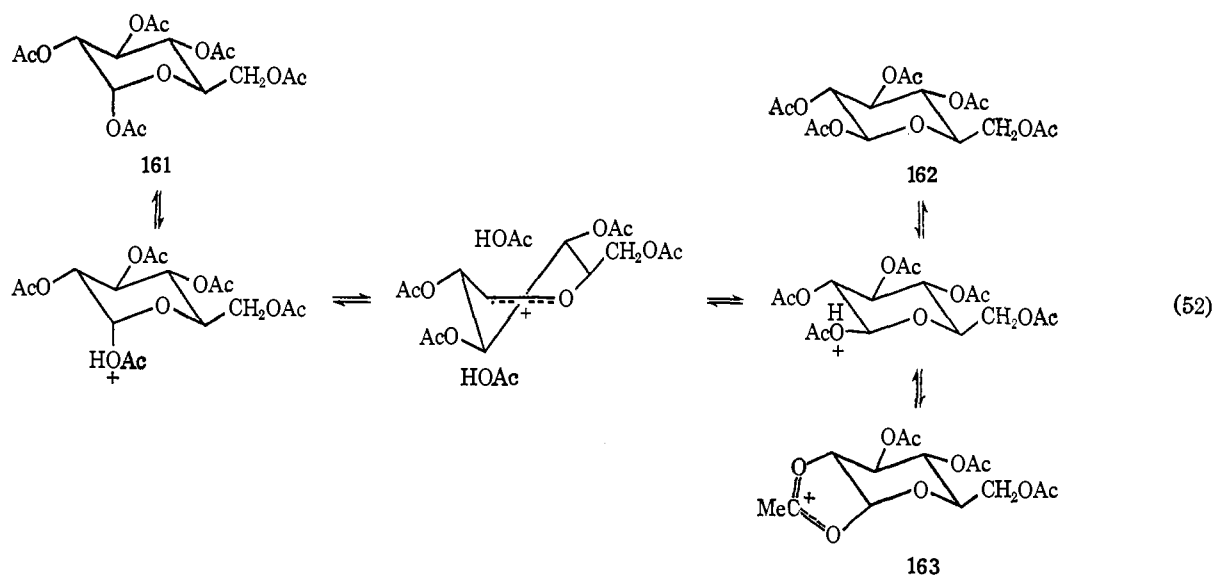

Table LXI

First-Order Rate Constants for Acetate Exchange and Anomerization of the Tetra-*O*-acetyl-2-deoxy-D-glucopyranoses at 25[°]⁵⁴⁹

Anomer	Solvent	[H ₂ SO ₄], M	10 ⁴ k _{exch.} , sec ⁻¹	10 ⁴ k _{anom.} , sec ⁻¹
α	1:1 Ac ₂ O-AcOH	0.001	5.0	1.37
	AcOH	0.002	4.87	2.67
β	1:1 Ac ₂ O-AcOH	0.001	23.5	10.9
	AcOH	0.002	36.3	20.2

clearly desirable. The mechanism of the conversion will be the reverse of that of the α → β conversion,⁵⁴⁸ but in addition the β-acetate must undergo an anchimerically assisted dissociation to give an ion, **163**, which reacts with solvent to re-form the β-pentaacetate. From the rate constants given in Table IX it follows that for every 68 anchimerically assisted dissociations there are approximately five which are unassisted. Similar results were obtained with the mannose pentaacetates, but here it is the α-acetate in which the groups at C(1) and C(2) have a *trans* disposition and which undergoes an anchimerically assisted dissociation. This assistance is not very large, however, and the β anomer which has the higher initial-state free energy undergoes exchange more rapidly.

The effect of successively replacing the hydrogen atoms of the acetoxyl groups at C(2) by chlorine atoms was also investigated by Lemieux, Brice, and Huber (Table LX).⁵⁴⁵ The rates of both anomerization and exchange are decreased, but the rate of exchange of the β anomer is decreased more than the rate of anomerization, so that for 1,3,4,6-tetra-*O*-acetyl-2-*O*-trichloroacetyl-β-D-glucose the two rates become almost identical. The decrease in the rate of exchange of the β anomer must be due to a lessening of the anchimeric assistance provided by the 2-acetoxyl group on replacing the hydrogen atoms by chlorines, which weaken its nucleophilicity. Another factor must be important, however, since the rate of exchange of the α anomer is also decreased, and this could be either the increase in nonbonding compression with increasing size of the 2-substituent on passing from the chair to the half-chair conformation or the greater electron-withdrawing inductive effect of chlorine compared to hydrogen.

As mentioned above, the rate of exchange of tetra-*O*-acetyl-2-deoxy-β-D-glucose is about twice the rate of anomerization, suggesting the intervention of a carbonium ion. The rate of exchange of the α anomer, however, in 1:1 acetic acid-acetic anhydride but not in pure acetic acid, is three to four times the rate of anomerization. This means that in AcOH-Ac₂O mixtures the α anomer has a pathway available for exchange which is not open to the β anomer. This could involve reaction with an acylium ion as shown in eq 53 or an anchimerically assisted dissociation as shown in eq 54.⁵⁴⁹

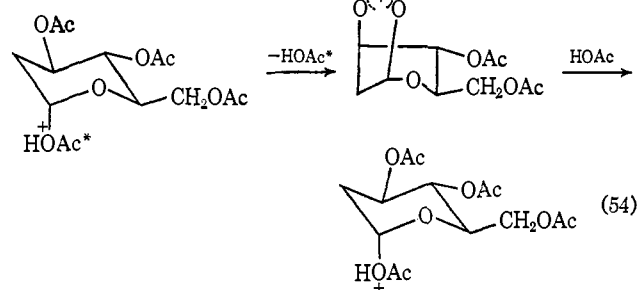
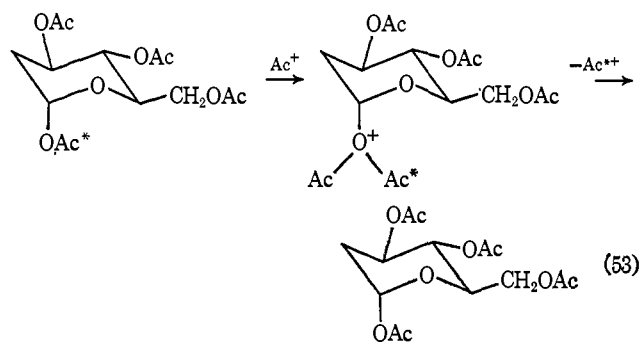

The relative rates of anomerization of the acetates of a series of aldoses (Table LXII)⁵⁵⁰ vary with their structures in a similar manner to the rates of solvolysis of acetylglycosyl halides (see section XII.A). They can be explained qualitatively in terms of the relative ease of formation of an ion in a half-chair conformation, except that penta-*O*-acetyl-α-D-manno-

Table LXII

First-Order Rate Constants for the Anomerization of Acetylated Aldopyranoses in 1:1 Acetic Acid-Acetic Anhydride Containing Sulfuric Acid (0.5 M) at 25°⁵⁵⁰

Fully acetylated aldopyranose	$10^4 k_{\alpha \rightarrow \beta}$	$10^4 k_{\beta \rightarrow \alpha}$
D-Glucose	0.90	4.72
D-Mannose	0.78	4.78
D-Galactose	2.77	10.4
6-Deoxy-D-glucose	10.9	51.5
D-Xylose	30.2	109
D-Ribose	36.6	10.7
L-Arabinose	57.5	50.8

Table LXIII

Relative Rates of Exchange of Acetate between 1,2-*trans* Sugar Acetates and Stannic Trichloride Acetate in Chloroform⁵⁵¹

Aldopyranose acetate	Relative rate	
	20°	40°
Tetra-O-acetyl-β-D-xylose	100	100
Tetra-O-acetyl-α-L-arabinose	81	100
Tetra-O-acetyl-β-D-ribose	5.3	11.9
Tetra-O-acetyl-α-D-lyxose	3.2	5.7
Penta-O-acetyl-α-D-altrose	23	21
Penta-O-acetyl-β-D-glucose	11.8	11.9
Penta-O-acetyl-β-D-galactose	8.7	10.6
Penta-O-acetyl-β-D-allose	...	2.0
Penta-O-acetyl-α-D-mannose	0.98	1.43
Tetra-O-acetyl-6-deoxy-β-D-glucose	...	7.8
Hexa-O-acetyl-D-glycero-β-D-guloheptose	0.032	...

pyranose reacts more slowly than might be expected. This is another indication that nucleophilic assistance by the solvent may be important and that the transition state may have bimolecular character.

The rates of exchange of a large number of 1,2-*trans* sugar acetates with stannic trichloride acetate labeled with ¹⁴C have also been measured (Table LXIII).⁵⁵¹ The low reactivities of the acetates of β-D-ribose, α-D-lyxose, β-D-allose, and α-D-mannose were attributed to the presence of *cis*-2,3-acetoxy groups, the acetoxy group at C(3) hindering the formation of the five-membered ring on C(1) and C(2) in the intermediate, cyclic ion. The reactivity sequence of pentose > hexose > heptose was attributed to the decreasing ease of conversion of the substituent at C(5) from an equatorial to a quasi-equatorial position in the half-chair ion.

XIV. Nucleophilic Displacement Reactions at Positions Other Than C(1) of Aldose Derivatives^{552a}

A. DISPLACEMENTS BY EXTERNAL NUCLEOPHILES AND NEIGHBORING GROUP PARTICIPATION BY RING ATOMS

Although a large number of nucleophilic displacement reactions at positions other than C(1) of aldoses have been reported (cf. ref 552b) there have been few quantitative kinetic measure-

(550) W. A. Bonner, *J. Amer. Chem. Soc.*, **81**, 1448 (1959).

(551) R. U. Lemieux and C. Brice, *Can. J. Chem.*, **34**, 1006 (1956).

(552) (a) An excellent review of neighboring group participation in reactions of sugars has appeared recently: L. Goodman, *Advan. Carbohydr. Chem.*, **22**, 109 (1967); (b) R. S. Tipson, *ibid.*, **8**, 180 (1953).

ments. Richardson has made the generalization that displacement at C(2) of hexopyranoses is difficult (cf. ref 553), but that displacement at C(6) is easy except in the *galacto* series.⁵⁵⁴ This latter point is illustrated by the kinetic results of Akagi, Tejima, and Haga⁵⁵⁵ given in Table LXIV which show that

Table LXIV

Second-Order Rate Constants for the Reaction of Hexopyranose-6-toluene-*p*-sulfonates with Sodium Iodide in Acetone at 100°⁵⁵⁵

Toluene- <i>p</i> -sulfonate	$10^3 k$, l. mole ⁻¹ sec ⁻¹
6- <i>O</i> -Toluene- <i>p</i> -sulfonyl-1,2,3,4-tetra- <i>O</i> -acetyl-α-D-glucose (164)	11.3
6- <i>O</i> -Toluene- <i>p</i> -sulfonyl-1,2,3,4-tetra- <i>O</i> -acetyl-β-D-glucose	5.33
6- <i>O</i> -Toluene- <i>p</i> -sulfonyl-2-acetamido-2-deoxy-1,3,4-tri- <i>O</i> -acetyl-α-D-glucose (165)	11.5
6- <i>O</i> -Toluene- <i>p</i> -sulfonyl-2-acetamido-2-deoxy-1,3,4-tri- <i>O</i> -acetyl-β-D-glucose	5.31
6- <i>O</i> -Toluene- <i>p</i> -sulfonyl-1,2,3,4-tetra- <i>O</i> -acetyl-α-D-galactose (166)	0.902
6- <i>O</i> -Toluene- <i>p</i> -sulfonyl-1,2,3,4-tetra- <i>O</i> -acetyl-β-D-galactose	0.288
Methyl 6- <i>O</i> -toluene- <i>p</i> -sulfonyl-2,3,4-tri- <i>O</i> -acetyl-α-D-glucoside (167)	12.1
Methyl 6- <i>O</i> -toluene- <i>p</i> -sulfonyl-2,3,4-tri- <i>O</i> -acetyl-β-D-glucoside	9.58
Ethyl 6- <i>O</i> -toluene- <i>p</i> -sulfonyl-2,3,4-tri- <i>O</i> -acetyl-β-D-glucoside	9.23
Isopropyl 6- <i>O</i> -toluene- <i>p</i> -sulfonyl-2,3,4-tri- <i>O</i> -acetyl-β-D-glucoside	8.52
<i>t</i> -Butyl 6- <i>O</i> -toluene- <i>p</i> -sulfonyl-2,3,4-tri- <i>O</i> -acetyl-β-D-glucoside	5.25
Phenyl 6- <i>O</i> -toluene- <i>p</i> -sulfonyl-2,3,4-tri- <i>O</i> -acetyl-β-D-glucoside	7.95
Methyl 6- <i>O</i> -toluene- <i>p</i> -sulfonyl-2,3,4-tri- <i>O</i> -acetyl-α-D-mannoside (168)	4.42

the galactose derivatives react 10 to 20 times slower than the corresponding glucose ones (see also ref 556-558). It was also shown that β react more slowly than α anomers and that

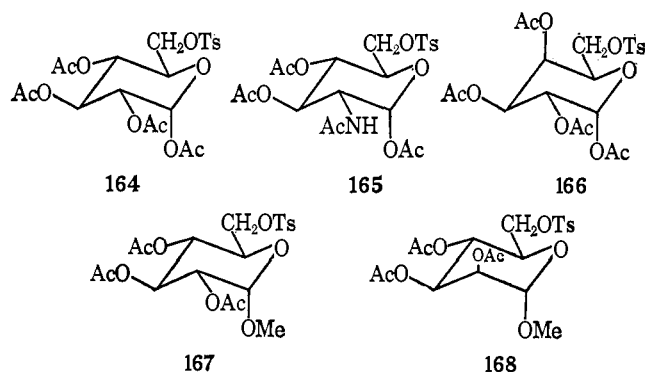

(553) H. J. Jennings and J. K. N. Jones, *Can. J. Chem.*, **43**, 2372 (1965).

(554) A. C. Richardson, *Ann. Rept. Chem. Soc.*, **62**, 371 (1965); see also Y. Ali and A. C. Richardson, *J. Chem. Soc.*, **C**, 1764 (1968); J. Hill, L. Hough, and A. C. Richardson, *Carbohydr. Res.*, **8**, 7 (1968).

(555) M. Akagi, S. Tejima, and M. Haga, *Chem. Pharm. Bull.* (Tokyo), **11**, 559 (1963).

(556) J. M. Sugihara and W. J. Teerlink, *J. Org. Chem.*, **29**, 550 (1964).

(557) B. Lindberg and S. Svenson, *Acta Chem. Scand.*, **21**, 299 (1967).

(558) S. Nadkarni and N. R. Williams, *J. Chem. Soc.*, 3496 (1965).

methyl 6-*O*-toluene-*p*-sulfonyl-2,3,4-tri-*O*-acetyl- α -D-mannopyranoside reacts about three times more slowly than the corresponding glucose derivative.

The slow rate of displacement of compounds with the *galacto* configuration can be rationalized in terms of the greater nonbonding interactions in the transition state **169**, owing to the presence of the axial substituent, than in transition state **170**, with an equatorial substituent.

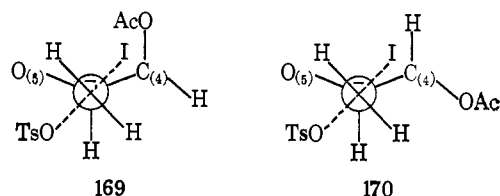

Several other displacement reactions on methylene groups attached to six-membered rings have been investigated and similar effects observed (see Table LXV).⁵⁵⁸ Thus compound

Table LXV

Second-Order Rate Constants for the Reaction of Primary Carbohydrate Benzenesulfonates with Sodium Iodide in Acetylacetone

Compound	$10^4 k$ at 80°, l. mole ⁻¹ sec ⁻¹	$10^4 k$ at 120°, l. mole ⁻¹ sec ⁻¹	Rel rate at 100°
1,2,3,4-Tetra- <i>O</i> -acetyl-6- <i>O</i> -(phenylsulfonyl)- β -D-glucopyranose	8.81	...	1.00
2,4:3,5-Di- <i>O</i> -methylene-1- <i>O</i> -(phenylsulfonyl)-DL-ribitol (D-isomer \equiv 171)	11.48	...	1.14
2,4:3,5-Di- <i>O</i> -methylene-1,6-di- <i>O</i> -(phenylsulfonyl)-D-mannitol	18.78	...	2.13
2,3,4,5-Di- <i>O</i> -benzylidene-1,6-di- <i>O</i> -(phenylsulfonyl)-D-mannitol	22.0	...	2.84
1,2:3,4-Di- <i>O</i> -isopropylidene-6- <i>O</i> -(phenylsulfonyl)-D-galactopyranose	...	2.35	0.00902
2,4:3,5-Di- <i>O</i> -methylene-1- <i>O</i> -(phenylsulfonyl)-DL-xylitol (L-isomer \equiv 172)	...	6.16	0.0235
2,4:3,5-Di- <i>O</i> -benzylidene-1- <i>O</i> -(phenylsulfonyl)-L-xylitol	...	1.65	0.00581

172 with an adjacent axial carbon-oxygen bond reacts more slowly than compound **171** with an equatorial one.

Direct displacement at C(3) or C(4) occurs fairly readily in dipolar aprotic solvents provided there is no β -*trans*-axial^{554,559} or α -*cis*-axial^{553,559-561} substituent. In the absence of these, displacement at C(4) seems to be favored over that at C(3) since methyl 2,3,4-tri-*O*-methanesulfonyl- β -D-xylopyranoside

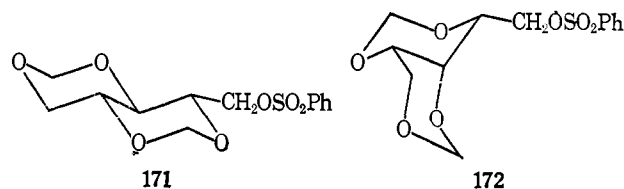

reacts preferentially at C(4) with sodium azide in dimethylformamide⁵⁵⁹ (see also ref 562).

The only kinetic investigation is that of the reactions of methyl 4,6-dideoxy-2,3-di-*O*-benzyl-4-iodo- α -D-galacto- and -glucopyranoside with radioactive iodide ion in acetone.⁵⁶³ The galacto compound reacts 2.8 and 2.4 times faster at 62.8 and 80.0°, respectively.⁵⁶³ Since both reactions have the same transition state (**173**), their relative rates are controlled by the initial-state energies and the results indicate that the free energy of the *galacto* isomer is 0.8 kcal mole⁻¹ greater than that of the *gluco* one.

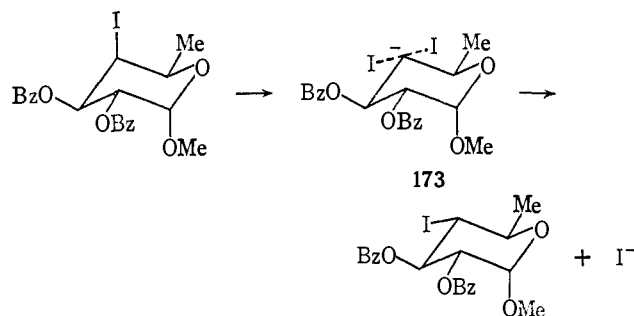

When a 2,3 double bond is introduced, as might be expected, the rate of displacement at C(4) is enormously increased. For instance, compound **174** undergoes preferential displacement of the C(4)-methanesulfonyloxy group on treatment with boiling water.⁵⁶⁴

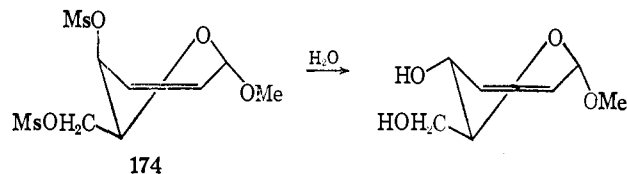

An axial substituent at C(2) decreases the rate of displacement of an equatorial group at C(4) so that attempts to carry out such displacements with rhamnose and mannose derivatives are often unsuccessful and lead to ring contraction with participation by the ring oxygen⁵⁶⁵⁻⁵⁶⁸ (but see ref 569). The most thoroughly studied example of this behavior is found with compound **175**, which on treatment with sodium acetate in dimethylformamide yields the ring-contracted compounds **176** and **177** in the ratio of 1:7.⁵⁶⁵ When heated to 170° in

(562) E. M. Acton, K. J. Ryan, and L. Goodman, *J. Amer. Chem. Soc.*, **89**, 467 (1967).

(563) C. L. Stevens, K. G. Taylor, and J. A. Valicenti, *ibid.*, **87**, 4579 (1965).

(564) D. M. Ciment, R. J. Ferrier, and W. G. Overend, *J. Chem. Soc., C*, 446 (1966).

(565) C. L. Stevens, R. P. Glinski, K. G. Taylor, P. Blumbergs, and F. Sirokman, *J. Amer. Chem. Soc.*, **88**, 2073 (1966).

(566) S. Hanessian, *Chem. Commun.*, 796 (1966).

(567) C. L. Stevens, R. P. Glinski, G. E. Gutowski, and J. P. Dickerson, *Tetrahedron Lett.*, 649 (1967).

(568) L. N. Owen, *Chem. Commun.*, 526 (1967).

(569) J. Jarý, P. Novák, Z. Ksandr, and Z. Samek, *Chem. Ind. (London)*, 1490 (1967); J. Jarý and P. Novák, *Collect. Czech. Chem. Commun.*, **33**, 1744 (1968).

(559) A. J. Dick and J. K. N. Jones, *Can. J. Chem.*, **44**, 79 (1966).

(560) A. G. Cottrell, E. Buncl, and J. K. N. Jones, *Chem. Ind. (London)*, 552 (1966); Y. Ali and A. C. Richardson, *J. Chem. Soc., C*, 320 (1969).

(561) A. G. Cottrell, E. Buncl, and J. K. N. Jones, *Can. J. Chem.*, **44**, 1483 (1966).

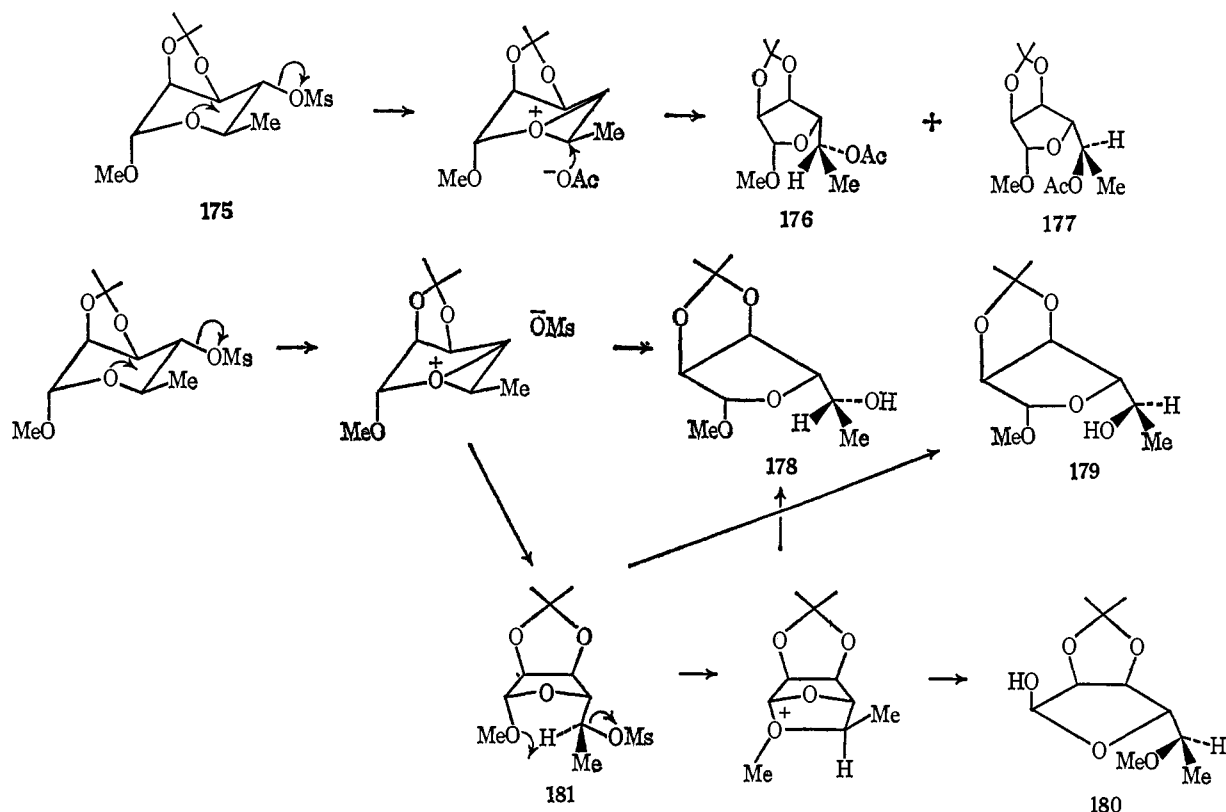

dioxane-water (9:1) in the presence of sodium hydrogen carbonate, **175** yielded **179**, **178**, and **180** in the ratio of 1:2:6. **180** is probably formed through rearrangement to **181** and subsequent methoxyl participation. Support for this was obtained by the observation that the *p*-bromobenzenesulfonate analogous to **181** yielded **179** (9%), **178** (2%), and **180** (89%) under the same reaction conditions. It is also possible that **177** and **179** are formed through a direct displacement by solvent on **181** since they have the same configuration at C(5) as **175**, and this apparent retention of configuration would then result from two inversions (*cf.* ref 568).

ucts can be rationalized as proceeding through the bicyclic oxonium ion **182**. Attack by water at C(4) would yield gluco-pyranoside, at C(5) altrofuranoside, and at C(1) the hemiacetal epoxide which after hydrolysis could yield glucose as shown. The galactopyranoside could arise either from a direct displacement or from an intermediate carbonium ion.⁵⁷⁰

Methyl 2-*O*-nitrobenzene-*p*-sulfonyl- α -D-glucoside is also hydrolyzed with participation by the ring oxygen to yield 2,5-anhydromannose (eq 55a),⁵⁷¹ and this reaction thus proceeds similarly to the deamination of D-glucosamine,⁵⁷² and methyl 2-amino-2-deoxy- α -D-glucoside.^{573a}

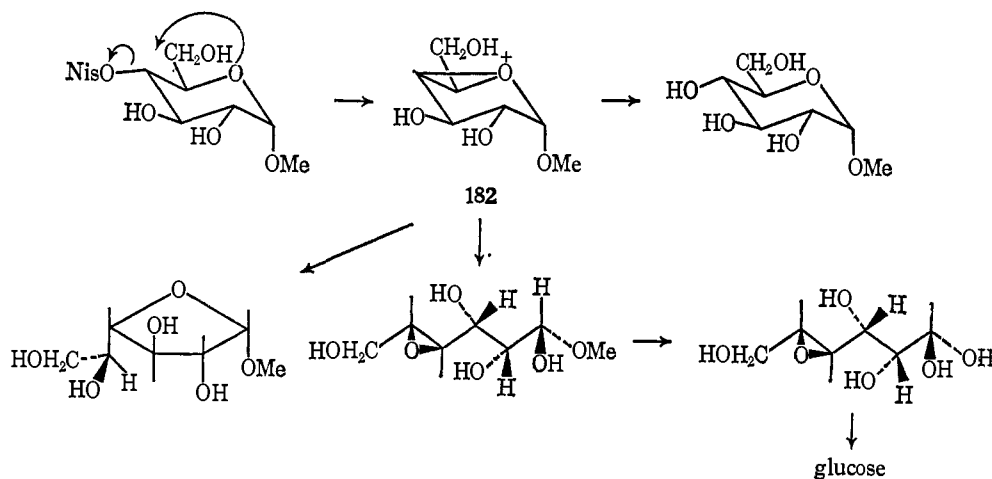

Participation by the ring oxygen in reactions at C(4) of glucose derivatives also occurs sometimes, as in the solvolysis of methyl 4-*O*-nitrobenzene-*p*-sulfonyl- α -D-glucoside in acetate buffer which yields methyl α -D-glucoside (\sim 50%), glucose (\sim 8%), methyl α -L-altrofuranoside (\sim 8%), and methyl α -D-galactopyranoside (\sim 8%). Formation of the first three prod-

(570) P. W. Austin, J. G. Buchanan, and D. G. Large, *Chem. Commun.*, 418 (1967).

(571) P. W. Austin, J. G. Buchanan, and R. M. Saunders, *J. Chem. Soc.*, C, 372 (1967).

(572) E. Fischer and F. Tiemann, *Ber.*, 27, 138 (1894).

(573) (a) B. C. Bera, A. B. Foster, and M. Stacey, *J. Chem. Soc.*, 4531 (1956); (b) N. A. Hughes, *Chem. Commun.*, 1072 (1967).

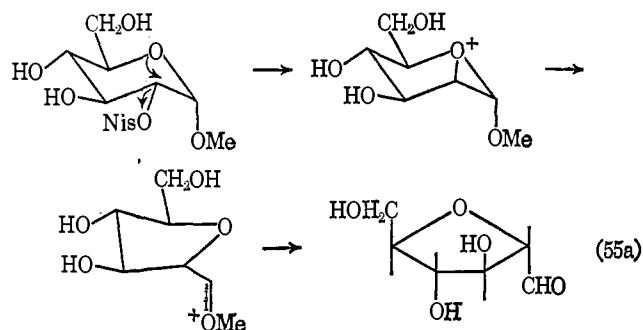

Participation by a bridge oxygen occurs when 1,6-anhydro-3,4-*O*-isopropylidene-2-*O*-methanesulfonyl- β -D-galactopyranose is treated with methanol containing potassium fluoride dihydrate at 130° to yield a mixture of methyl 2,5-anhydro-3,4-isopropylidene- α - and - β -talopyranoside in which the β -*exo* isomer probably predominates (see eq 55b).^{573b}

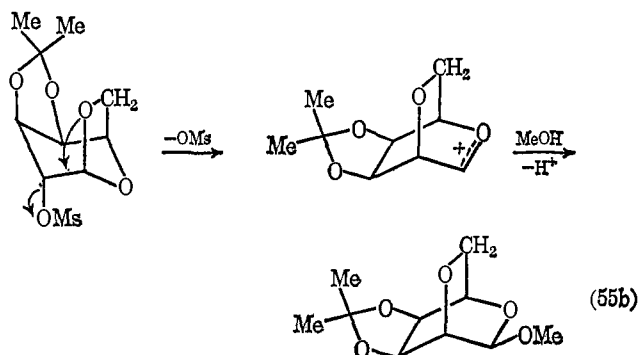

The effect of an axial substituent at C(1) on the reactivity at C(3) is illustrated by the observation that 1,2,4,6-tetra-*O*-benzoyl-3-*O*-toluene-*p*-sulfonyl- β -D-glucopyranose reacts readily with tetra-*n*-butylammonium benzoate (eq 56) whereas its α anomer does not (eq 57).⁵⁷⁴ An axial substituent at C(4) also has a rate-decreasing effect. For example, the

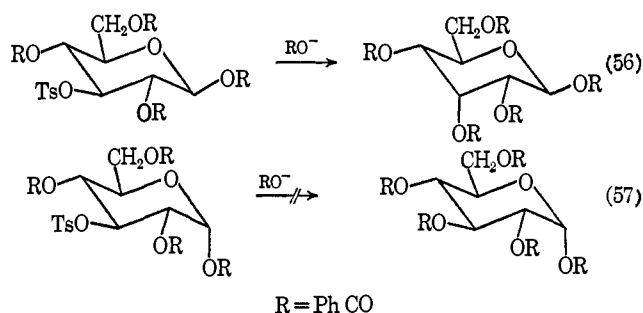

methanesulfonyloxy group at C(3) of methyl 4-azido-4-deoxy-2,3-di-*O*-methanesulfonyl- β -D-xyloside (**183**) is displaced on treatment with sodium azide in dimethylformamide whereas that of the corresponding α -L-arabinoside (**184**) is not.⁵⁵⁹ This

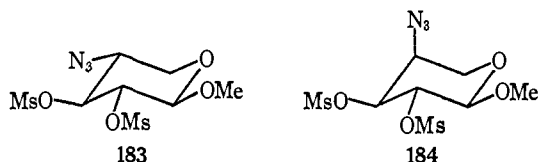

(574) N. A. Hughes and P. R. H. Speakman, *J. Chem. Soc.*, 2236 (1965); see also R. Ahluwalia, S. J. Angyal, and M. H. Randall, *Carbohydr. Res.*, **4**, 478 (1967).

effect presumably results from nonbonding interactions between the axial substituent and the leaving group in the transition state, e.g., as shown in **185**.

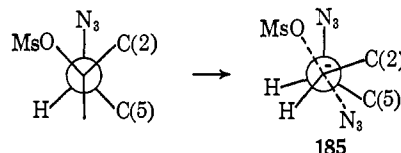

The slowness of displacement reactions at C(2) is almost certainly the result of there being two oxygen groups at C(1) with electron-withdrawing inductive effects.⁵⁵³ Alkoxy groups in the β position normally cause a rate decrease in S_N2 reactions.⁵⁷⁵

Displacement reactions at C(3) can also proceed with ring contraction, but this involves carbon not oxygen participation. Thus solvolysis of methyl 3-*O*-nitrobenzenesulfonyl- α -D-glucoside (**186**) in aqueous acetate buffer (pH 5) at 100° occurs with participation of the anti-C(2)–C(3) bond to yield the hemiacetal of methyl 3-deoxy-3-formyl- α -D-xylofuranoside (see eq 58).^{571,576} Similar reactions occur with the *O*-nitrobenzenesulfonylmannopyranoside⁵⁷¹ and on deamination of methyl 3-amino-3-deoxygluco- and -mannopyranoside.^{571,577} Presumably the hydroxyl group at C(4) facilitates migration of the C(4)–C(5) bond by its electron-releasing mesomeric effect as shown.

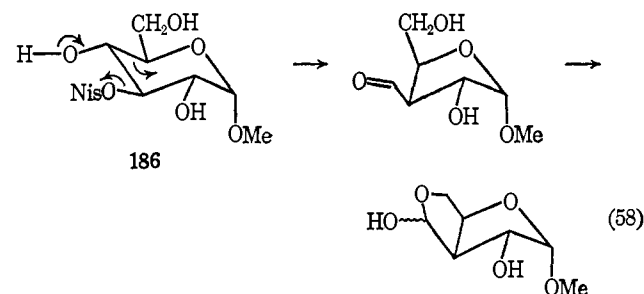

Displacement reactions on the sulfur of carbohydrate sulfonate esters sometimes take place (see ref 578). Probably the best known example is that which occurs in the conversion of methyl 4,6-*O*-benzylidene-2,3-di-*O*-toluene-*p*-sulfonyl- α -D-glucoside into methyl 2,3-anhydro-4,6-benzylidene- α -D-alloside (see eq 59). Another example is found in the reaction of methyl 2-*O*-methanesulfonyl-3,4,6-tri-*O*-methyl- α -D-glucoside in dimethyl sulfoxide to yield a mixture of methyl 2,3,4,6-tetra-*O*-methyl- α -D-glucoside and methyl 3,4,6-tri-*O*-methyl- α -D-glucoside. When this reaction is carried out with ¹⁸O-labeled methoxide there is no incorporation of ¹⁸O into the sugar. It was suggested that methyl methanesulfonate was formed first and that some of this reacted with the anion of methyl 3,4,6-tri-*O*-methyl- α -D-glucoside possibly in a solvent cage (eq 60).^{579,580}

(575) A. Streitwieser, "Solvolytic Displacement Reactions," McGraw-Hill Book Co., Inc., New York, N. Y., 1962, p 17, Table 6.

(576) P. W. Austin, J. G. Buchanan, and R. M. Saunders, *Chem. Commun.*, 146 (1965).

(577) (a) S. Inoue and H. Ogawa, *Chem. Pharm. Bull. (Tokyo)*, **8**, 79 (1960). (b) A small amount of migration of the C(1)–C(2) bond as well as migration of the C(4)–C(5) bond has been found to occur in the deamination of methyl 3-amino-3-deoxy- α -D-xyloside; E. J. Reist, D. F. Calkins, and L. Goodman, *J. Amer. Chem. Soc.*, **90**, 3852 (1968).

(578) F. H. Newth, *Quart. Rev. (London)*, **13**, 37 (1959).

(579) D. H. Ball, E. D. M. Eades, and L. Long, *J. Amer. Chem. Soc.*, **86**, 3579 (1964).

(580) E. D. M. Eades, D. H. Ball, and L. Long, *J. Org. Chem.*, **31**, 1159 (1966).

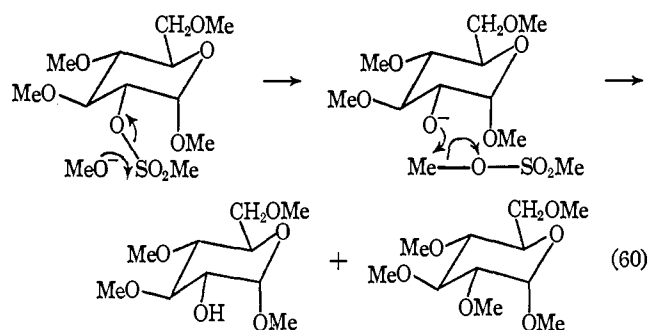
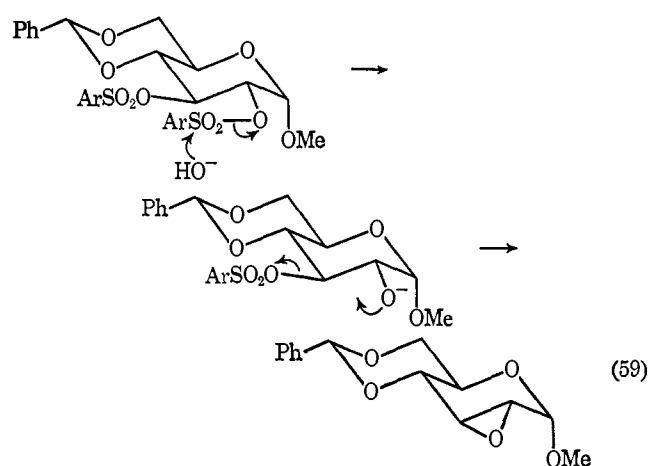

Nucleophilic displacement reactions on furanose rings generally occur quite readily unless the leaving group is *exo* in a bicyclic system with two fused five-membered rings.^{581-584b} Thus whereas 1,2:5,6-di-*O*-isopropylidene-3-*O*-toluene-*p*-sulfonyl- α -D-allofuranose (**187**) reacts quite rapidly with sodium azide in dimethylformamide^{585, 586} (see also ref 587, 588), the analogous *gluco* compound (**188**) does not.⁵⁸⁹ Another example is found in the reactions of the 1,2-*O*-isopropylidene-3,5-di-*O*-toluene-*p*-sulfonylpentafuranoses with tetra-*n*-butylammonium benzoate in *N*-methyl-2-pyrrolidone at 100–105°. The primary toluene-*p*-sulfonyl groups of the *ribo* (**189**), *xylo* (**190**), and *arabino* (**191**) compounds are all displaced rapidly, but the secondary toluene-*p*-sulfonyl group of only the *ribo* compound reacts under these conditions. The high reactivity of the latter is not the result of neighboring group participation as shown in **192**, because the toluene-*p*-sulfonyl group of 5-deoxy-1,2-*O*-isopropylidene-3-*O*-toluenesulfonyl-D-ribofuranose (**193**) is displaced at a similar rate.⁵⁹⁰

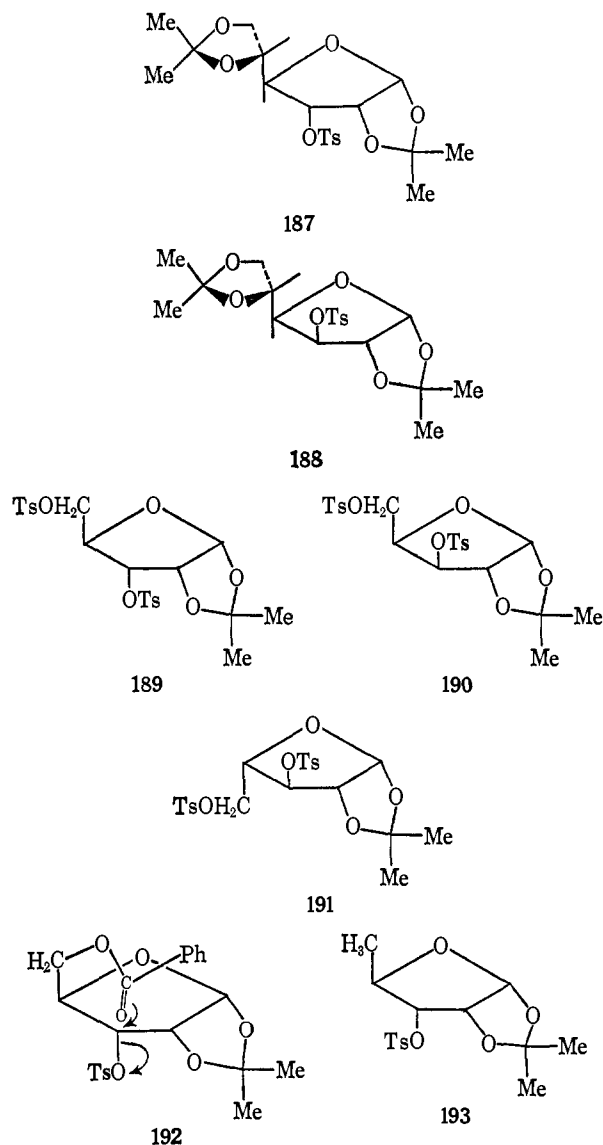

The generally accepted explanation for the low reactivity of the *exo* compounds is that approach of a nucleophile from the *endo* direction is hindered sterically and/or by electrostatic repulsion from the oxygens of the sugar.⁵⁸⁹ This implies that the difference in reactivities of the *exo* and *endo* isomers is solely the result of a difference in the energies of the transition states. In the reviewer's opinion initial-state energies may be more important, and the relatively high reactivity of the *endo* isomers may be due mainly to their higher free energies compared to those of the corresponding *exo* isomers. Unfortunately, a symmetrical displacement (*e.g.*, iodide exchange) in which the transition state would be the same for the reactions of both isomers does not appear to have been investigated.

Displacement reactions of *exo*-toluene-*p*-sulfonates do sometimes occur, especially when the nucleophile is an amine⁵⁸⁴ or hydrazine.⁵⁸⁹ Thus 1,2:5,6-di-*O*-isopropylidene-3-*O*-toluene-*p*-sulfonyl- α -D-glucopyranose reacts with anhydrous hydrazine to yield the 3-hydrazinoallose derivatives, but unfortunately there is no comparison of the rate of this reaction with that of its *endo* isomer, and hence also no comparison of the relative rates of reactions of *exo* and *endo* isomers with hydrazine and a charged nucleophile. It was suggested that the reaction with hydrazine might be assisted by intramolecular general base catalysis by the sugar oxygens as shown in **194**.⁵⁸⁹

(581) L. F. Wiggins and D. J. C. Wood, *J. Chem. Soc.*, 1180 (1951).

(582) N. K. Matheson and S. J. Angyal, *ibid.*, 1133 (1952).

(583) J. A. Mills, *Advan. Carbohydr. Chem.*, 10, 47 (1955).

(584) (a) A. C. Cope and T. Y. Shen, *J. Amer. Chem. Soc.*, 78, 3177 (1956); (b) J. S. Brimacombe, P. A. Gent, and M. Stacey, *J. Chem. Soc.*, C, 567 (1968).

(585) J. S. Brimacombe, J. G. H. Bryan, A. Husain, M. Stacey, and M. S. Tolley, *Carbohydr. Res.*, 3, 318 (1967).

(586) D. T. Williams and J. K. N. Jones, *Can. J. Chem.*, 45, 7 (1967).

(587) W. Meyer zu Reckendorf, *Angew. Chem. Intern. Ed. Engl.*, 5, 967 (1966).

(588) K. W. Buck, A. B. Foster, R. Hems, and J. M. Webber, *Carbohydr. Res.*, 3, 137 (1967).

(589) M. L. Wolfrom, J. Bernsmann, and D. Horton, *J. Org. Chem.*, 27, 4505 (1962); see also L. Hough and A. C. Richardson in "Rodd's Chemistry of Carbon Compounds," Vol. 1F, S. Coffey, Ed., Elsevier, London, 1967, p 54; A. K. Chatterjee, D. Horton, and J. S. Jewell, *Carbohydr. Res.*, 7, 212 (1968).

(590) N. A. Hughes and P. R. H. Speakman, *ibid.*, 1, 341 (1966).

Displacement of the toluene-*p*-sulfonyloxy group of 1,2-*O*-isopropylidene-3-*O*-toluene-*p*-sulfonyl-D-xylofuranose by thiocyanate in dimethylformamide occurs much more readily than that of the corresponding 5-*O*-trityl and 5-deoxy derivatives. It was suggested that intramolecular electrophilic assistance was provided by the hydroxyl group at C(5) as shown in **195**.⁵⁹¹

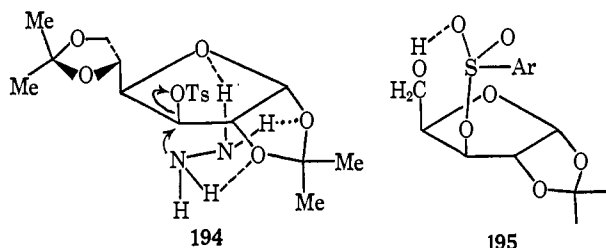

B. NEIGHBORING GROUP PARTICIPATION BY HYDROXYL SUBSTITUENTS

Neighboring group participation by ionized hydroxyl groups occurs in the synthesis of anhydro sugars, and O⁻(5) (e.g., eq 61)⁵⁹² and O⁻(3) (e.g., eq 62 and 63)^{593,594} participation are quite common (cf. ref 595-597) although no kinetic measurements have been published so far.

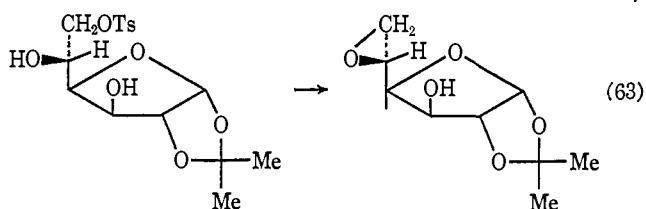
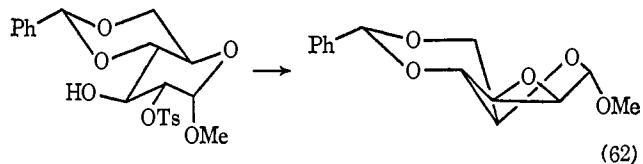
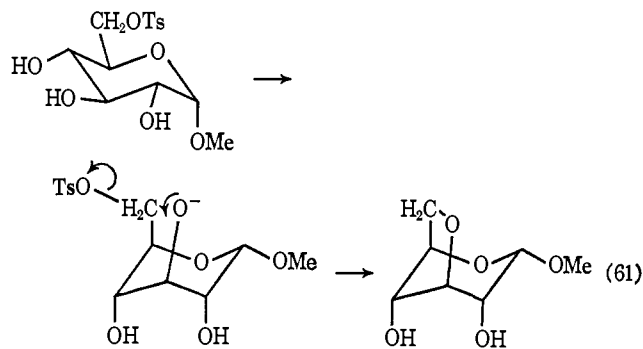

As shown in eq 61 treatment of methyl 6-*O*-toluene-*p*-sulfonyl- α -D-glucoside with sodium methoxide results in participation of the hydroxyl group at C(3). When there is a hydroxyl group at C(1), however, this group participates in preference to that at C(3), as shown by the observation that

6-*O*-toluene-*p*-sulfonyl-1,2,3,4-tetra-*O*-acetyl- β -D-glucose, on treatment with sodium methoxide, yields 1,6-anhydroglucose (eq 64).^{598a} Presumably, the important factor here is that the predominating conjugate base is that with the hydroxyl at C(1) ionized. Other examples of O⁻(5) participation by the hydroxyl group at position 1 of an aldose derivative are described in ref 598b.

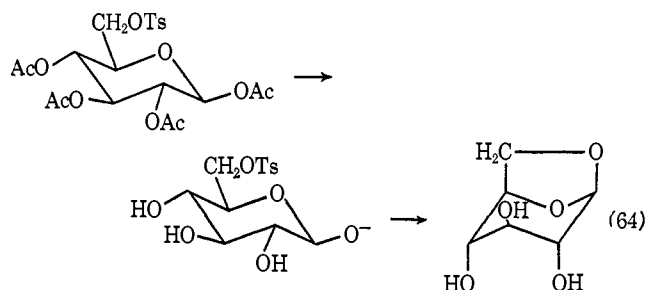

Competition between O⁻(5) and O⁻(6) and O⁻(3) participation in the reactions of a number of *O*-toluene-*p*-sulfonyl-alditols and -deoxyalditols has been investigated by Hartman and Barker.^{599,600} In the alkaline ring closure of ω -chloro alcohols the anchimeric assistance decreases in the order O⁻(3) > O⁻(5) > O⁻(6), but this order is not always followed with the *O*-toluene-*p*-sulfonyl-alditols. Thus alkaline treatment of 1-*O*-toluene-*p*-sulfonyl-D-erythritol (**196**) yields 1,4-anhydroerythritol (**197**). It was considered that this is formed by a

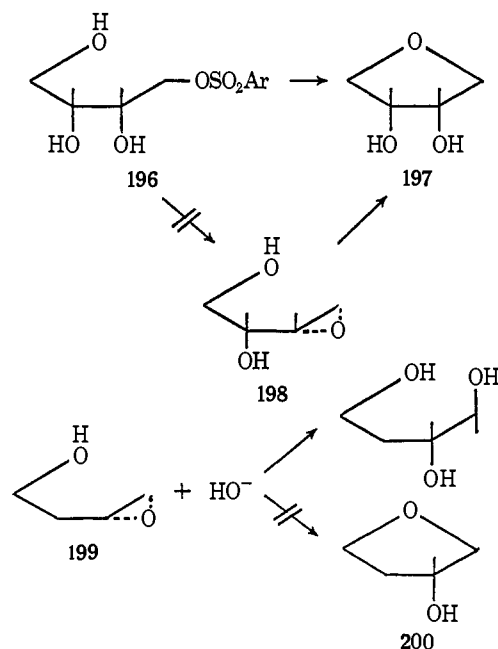

direct intramolecular displacement rather than *via* the epoxide **198**, since epoxide **199** yielded none of tetrahydrofuran **200** on treatment with alkali. Similar O⁻ participation probably occurs when teichoic acids are treated with alkali. This involves formation of 1,4-anhydroribitol with a phosphate ester as leaving group.⁶⁰¹

(591) J. Defaye and J. Hildesheim, *Carbohydr. Res.*, **4**, 145 (1967).

(592) W. N. Haworth, L. N. Owen, and F. Smith, *J. Chem. Soc.*, **88** (1941).

(593) G. J. Robertson and C. E. Griffiths, *ibid.*, 1193 (1935).

(594) H. Ohle and L. von Vargha, *Ber.*, **62**, 2435 (1929).

(595) J. C. Sowden in "The Carbohydrates," W. W. Pigman, Ed., Academic Press, New York, N. Y., 1957, p 376.

(596) F. Micheel and A. Klemmer, "Chemie der Zucker und Polysaccharide," Akademische Verlags-Gesellschaft Geest and Portig K.G., Leipzig, 1956, p 141.

(597) S. Peat, *Advan. Carbohydr. Chem.*, **2**, 37 (1946).

(598) (a) M. Akagi, S. Tejima, and M. Haga, *Chem. Pharm. Bull. (Tokyo)*, **10**, 905 (1962); (b) J. S. Brimacombe and L. C. N. Tucker, *Carbohydr. Res.*, **5**, 36 (1967).

(599) F. C. Hartman and R. Barker, *J. Org. Chem.*, **28**, 1004 (1963).

(600) F. C. Hartman and R. Barker, *ibid.*, **29**, 873 (1964).

(601) D. A. Applegarth, J. G. Buchanan, and J. Baddiley, *J. Chem. Soc.*, 1213 (1965).

Undoubtedly an important factor in making O⁻(3) participation with ω -chloro alcohols so efficient is the high standing concentration of the conjugate base of 2-chloroethanol arising from the acid-strengthening effect of the adjacent electron-withdrawing chlorine. With the 1-*O*-toluene-*p*-sulfonyl-D-erythritol, the hydroxyl at C(4) has an adjacent electron-withdrawing substituent (OH) as well as the hydroxyl at C(2). Hence the difference in the standing concentrations of conjugate bases with the 2- and 4-hydroxyl groups ionized may be less than the difference in the concentrations of the conjugate bases of 2-chloroethanol and 4-chlorobutanol. Other factors which may be important are that the 2-hydroxyl group is secondary and the 4-hydroxyl group primary and that the reaction involves cyclization of a substituted chain which usually proceeds more rapidly than that of an unsubstituted one (*cf.* ref 187). Some idea of the relative importance of these effects is given by the observation that compound **201** (configuration unspecified), in which the 4-hydroxyl group is secondary and which lacks an adjacent hydroxyl group, reacts with alkali with only a slight predominance of O⁻(5) over O⁻(3) participation. Also O⁻(5) participation occurs with

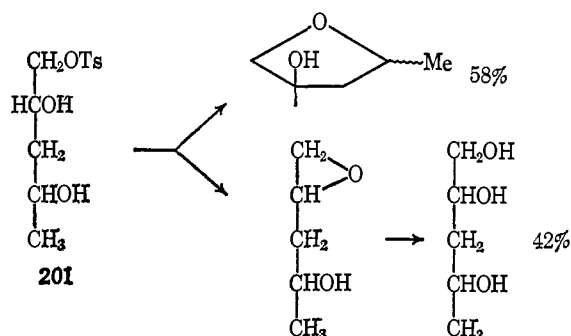

compound **202** (after removal of the benzoate groups) to the extent of less than 7.5% as judged by the optical purity of the product, tetrahydrofurfuryl alcohol. This is predominantly of the L configuration and thus formed *via* epoxide **203** rather than by a direct intramolecular displacement of the toluene-*p*-sulfonyl group.

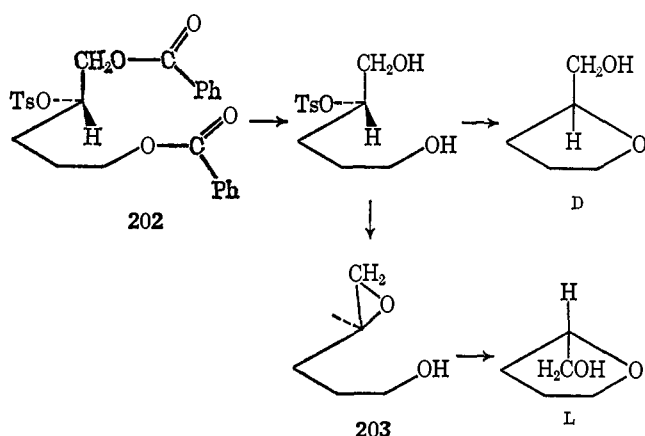

O⁻(6) participation competes unfavorably with O⁻(3) participation when compound **204** is treated with alkali; 92.5% of tetrahydrofurfuryl alcohol (**206**) and only 7.5% of 3-hydroxy-tetrahydropyran (**205**) are formed.⁶⁰⁰

Several examples of O⁻(4) participation are also known. The first of these to be reported was the reaction of 1,2-*O*-isopropylidene-5-*O*-toluene-*p*-sulfonyl- α -D-xylofuranose with

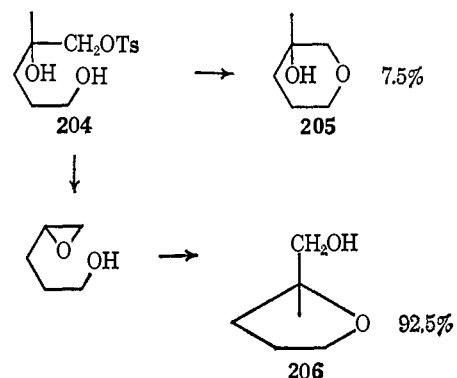

sodium methoxide to yield 3,5-anhydro-1,2-*O*-isopropylidene- α -D-xylofuranose (eq 65)⁶⁰² (see also ref 603–607). This conversion may also be brought about by treatment with silver

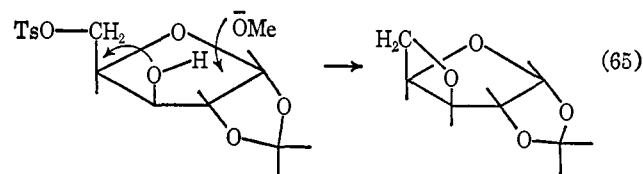

fluoride in pyridine⁶⁰⁸ (see also ref 609). 3,5-Anhydrofuranose derivatives may also be formed by participation of the 5-hydroxyl group in reactions of a 3-toluene-*p*-sulfonate but the yields are low (*cf.* eq 66).⁶¹⁰

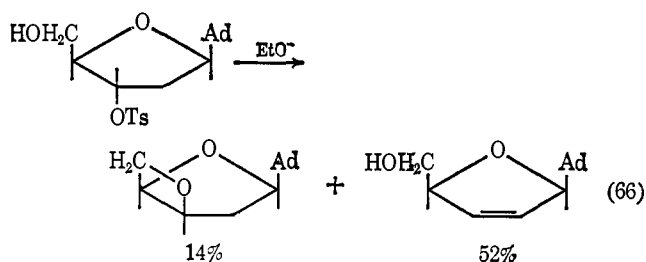

Sometimes O⁻(4) participation even competes successfully with O⁻(6) participation. Thus 1-*O*-toluene-*p*-sulfonyl-2,4-methylene-D-xylitol (**207a**) and 6-*O*-methyl-1-*O*-toluene-*p*-sulfonyl-2,4-di-*O*-benzylidene-D-glucitol (**207b**) yield the 1,3-not the 1,5-anhydrides (eq 67,^{611,612} see also ref 613).

Treatment of 1-*O*-toluene-*p*-sulfonyl-2,4-di-*O*-methylene-glucitol with sodium hydroxide yields the 1,5-anhydride, however (eq 68).⁶¹⁴

(602) P. A. Levene and A. L. Raymond, *J. Biol. Chem.*, 102, 331 (1933).

(603) J. P. Horwitz, J. Chua, J. A. Urbanski, and M. Noel, *J. Org. Chem.*, 28, 942 (1963).

(604) J. P. Horwitz, J. Chua, M. A. Da Rooze, M. Noel, and I. L. Klundt, *ibid.*, 31, 205 (1966).

(605) I. L. Doerr, J. F. Codington, and J. J. Fox, *ibid.*, 30, 467 (1965).

(606) J. F. Codington, I. L. Doerr, and J. J. Fox, *ibid.*, 30, 476 (1965).

(607) J. P. Horwitz, J. Chua, J. A. Urbanski, and M. Noel, *ibid.*, 28, 942 (1963).

(608) L. Hough and B. Otter, *Chem. Commun.*, 173 (1966).

(609) L. Hough and B. A. Otter, *Carbohydr. Res.*, 4, 126 (1967).

(610) J. P. Horwitz, J. Chua, and M. Noel, *Tetrahedron Lett.*, 1343 (1966).

(611) R. M. Hann, N. K. Richtmeyer, H. W. Diehl, and C. S. Hudson, *J. Amer. Chem. Soc.*, 72, 561 (1950).

(612) E. Haslam and T. Radford, *Chem. Commun.*, 631 (1965).

(613) G. E. Utsyuzhanen, N. S. Tikhomorova-Sidorova, and S. N. Danilov, *J. Gen. Chem. USSR*, 33, 445 (1963).

(614) S. B. Baker, *Can. J. Chem.*, 32, 628 (1954).

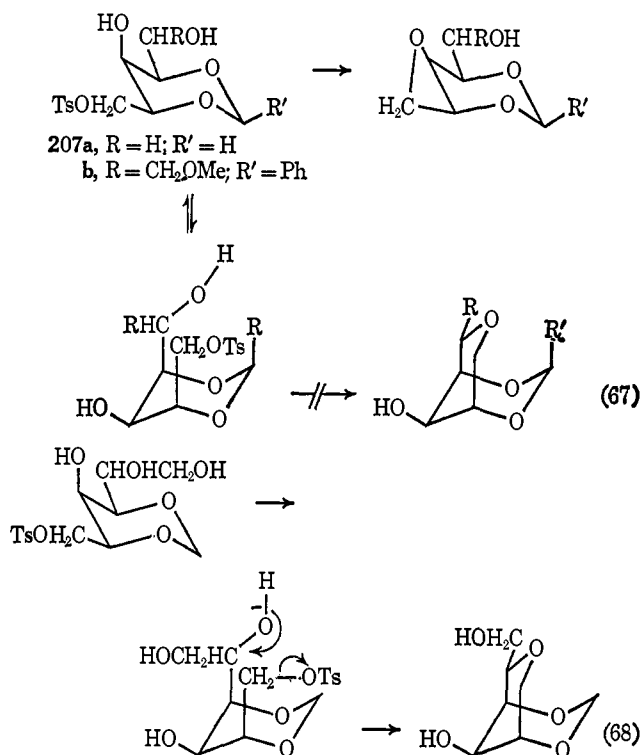

It has been suggested that O⁻(4) participation occurs in the conversion of 6-*O*-benzyl-1,2-*O*-isopropylidene-5-toluene-*p*-sulfonyl- α -D-glucufuranose (**208**) into the enol ether **210** (see eq 69a) on the grounds that the corresponding 3-*O*-methyl derivative did not undergo this reaction.⁶¹⁵ Oxetane **209** was postulated as an intermediate, but it seems unlikely that this can be so as the corresponding 6-*O*-trityloxetan is stable under the reaction conditions. It seems more likely then that the ionized hydroxyl group at C(3) acts as a base as shown in eq 69b rather than as a nucleophile.⁶¹⁶

Neighboring group participation by ionized hydroxyl groups is also found in reactions of sugar sulfates, and its occurrence or nonoccurrence has been used to assign the position of sulfate groups in polysaccharides (*cf.* ref 617).

"Oxide migrations" are another interesting class of reactions involving neighboring group participation by an ionized hydroxyl group.⁶¹⁸ They have been studied extensively by Buchanan and his coworkers^{616, 619-622} and by Černý, Pacák, and Staněk,^{623, 624} and examples of O⁻(5) (*e.g.*, eq 70),⁶²⁵ O⁻(4) (*e.g.*, eq 71),⁶²¹ and O⁻(3) (*e.g.*, eq 72)⁶²² participation have been reported. Although equilibrium constants for several of these reactions have been measured, there have been no detailed kinetic measurements, and they will not be discussed in detail here.

(615) R. E. Gramera, T. R. Ingle, and R. L. Whistler, *J. Org. Chem.*, **29**, 1083 (1964).

(616) J. G. Buchanan and E. M. Oakes, *Carbohydr. Res.*, **1**, 242 (1965).

(617) J. R. Turvey, *Advan. Carbohydr. Chem.*, **20**, 201 (1965).

(618) F. H. Newth, *Quart. Rev. (London)*, **13**, 43 (1959); R. U. Lemieux in ref 36a, Part 2, p 757.

(619) J. G. Buchanan, *J. Chem. Soc.*, 995 (1958).

(620) J. G. Buchanan and R. Fletcher, *ibid.*, 6316 (1965).

(621) P. W. Austin, J. G. Buchanan, and E. M. Oakes, *Chem. Commun.*, 374, 472 (1965).

(622) J. G. Buchanan and R. Fletcher, *J. Chem. Soc., C*, 1926 (1966); J. G. Buchanan, R. Fletcher, K. Parry, and W. A. Thomas, *ibid.*, **B**, 377 (1969).

(623) M. Černý, I. Buben, and J. Pacák, *Collect. Czech. Chem. Commun.*, **28**, 1569 (1963).

(624) M. Černý, J. Pacák, and J. Staněk, *ibid.*, **30**, 1151 (1965).

(625) S. Peat and L. F. Wiggins, *J. Chem. Soc.*, 1088 (1938).

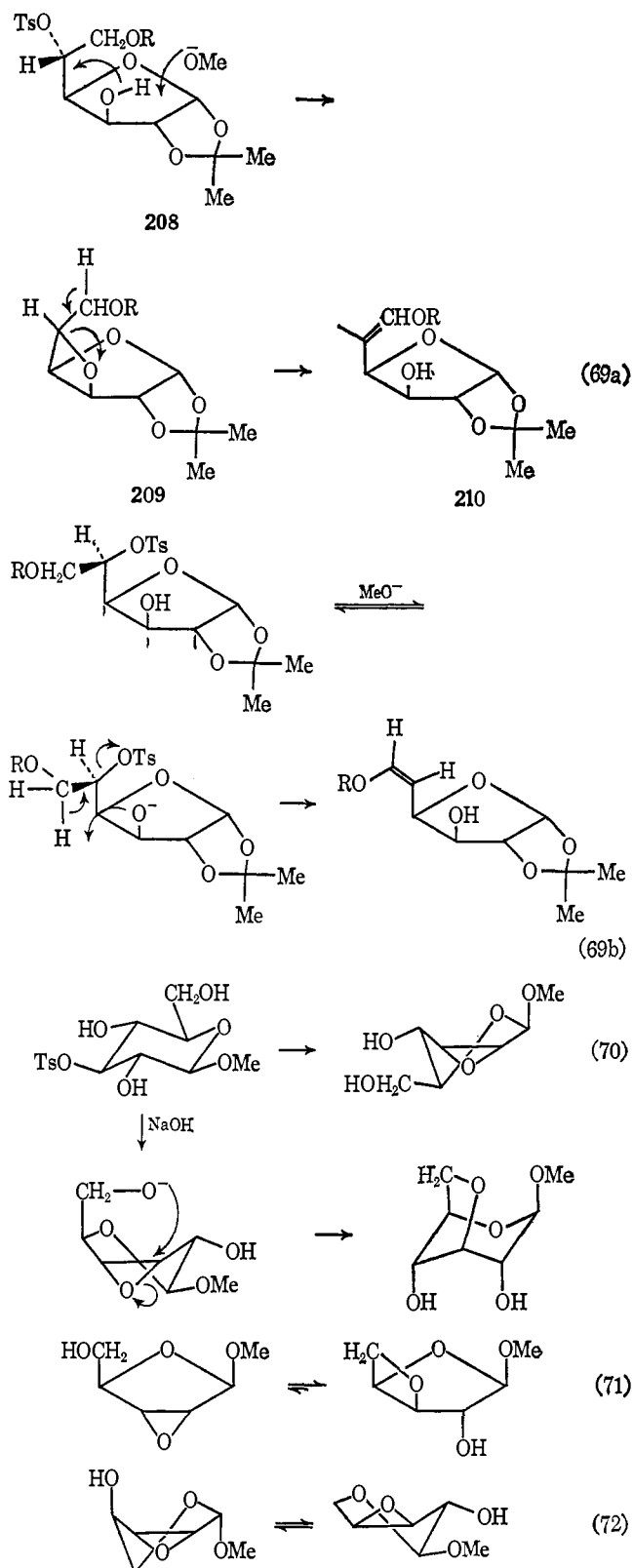

C. NEIGHBORING GROUP PARTICIPATION BY ALKOXYL SUBSTITUENTS^{552a}

Participation by benzyloxy groups occurs in the reactions of the 2,3,4-tri-*O*-benzyl-1,5-di-*O*-toluene-*p*-sulfonylribitol, -arabinitol, and -xylitol in 95% ethanol (eq 73).^{626a} The rate constant (after symmetry correction) for the ribitol compound is about 10 times smaller than those for the other two. The

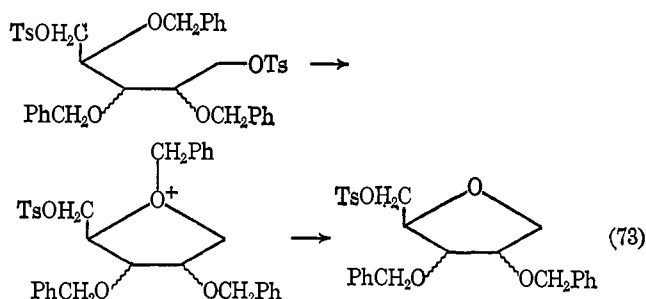

arabinitol compound **212** yields only the anhydroarabinitol **213** and not the anhydroxyxitol **211**. This must result from a difference in the energies of the transition states, with that for the formation of the anhydroxyxitol being higher as a result of the nonbonding interactions between the three *cis* substituents in the forming five-membered ring.

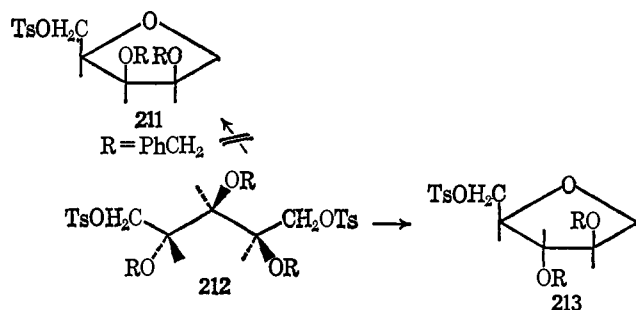

A consideration of nonbonded interactions in the other rings predicts that if the transition states resembled the final rings the energy of the *arabino* transition state (**214**) (no vicinal *cis* substituents) would be less than that of the *xylo* and *ribo* transition states (**215** and **216**) (two vicinal *cis* substituents). The fact that the *xylo* and *arabino* compounds react at similar rates therefore suggests that initial-state energies are also important. These are difficult to evaluate, but it would not be unreasonable for the *xylo* compound to have the highest initial-state energy since it is the one which in its zig-zag conformation (**217**) has the three benzyloxy groups *cis*.

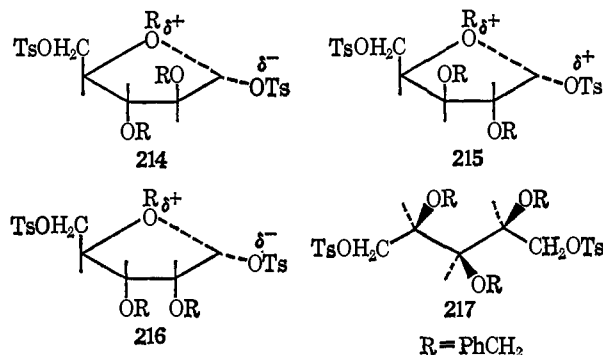

Participation by a benzyloxy group of a pyranose derivative occurs when methyl 2,3-di-*O*-benzyl-6-*O*-methanesulfonyl- β -D-galactopyranoside is heated in buffered methanolic solution to yield 3,6-anhydro 2-*O*-benzyl- β -D-galactopyranoside. The fate of the benzyl group which was lost was not reported.^{626b}

Participation by an acetal methoxyl group occurs when the ribose derivative **218** is treated with tetrabutylammonium benzoate in 1-methylpyrrolidone. Instead of giving the ex-

pected 4-*O*-benzoyl-L-lyxose derivative, this reaction gave the methylhemiacetal 1-benzoate **220** presumably *via* the cyclic oxonium ion **219**.⁶²⁷ Participation by a glycosidic methoxyl group has recently been demonstrated to occur in the hydrolyses of methyl 4-*O*-nitrobenzene-*p*-sulfonyl- β -D-xyloside and - β -D-glycoside which yield *inter alia* 4-*O*-methyl-L-arabinose and 4-*O*-methyl-D-glucose, respectively.⁶²⁸

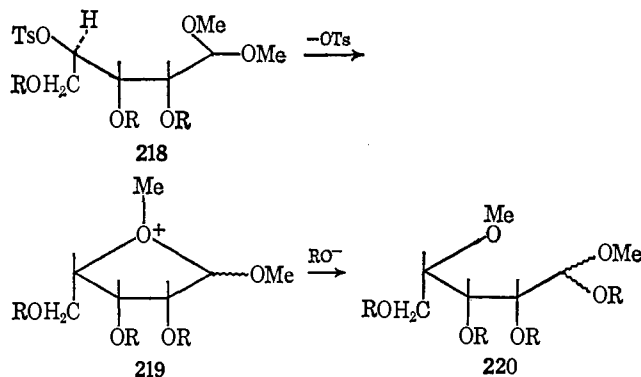

Another example of neighboring group participation by a methoxyl group is described in ref 565.

D. NEIGHBORING GROUP PARTICIPATION BY THIOETHER AND THIOL SUBSTITUENTS^{552a}

Several examples of participation by thioether groups have been reported in reactions of sugar derivatives. S(3) participation is illustrated by the reaction of methyl 3-deoxy-3-(ethylthio)- β -D-xylofuranoside with toluene-*p*-sulfonyl chloride to yield a mixture of the chloro compounds **222** and **223**. Acetyloysis of this mixture which yields a mixture of the corresponding acetates probably involves the same episulfonium ion (**221**).⁶²⁹⁻⁶³³

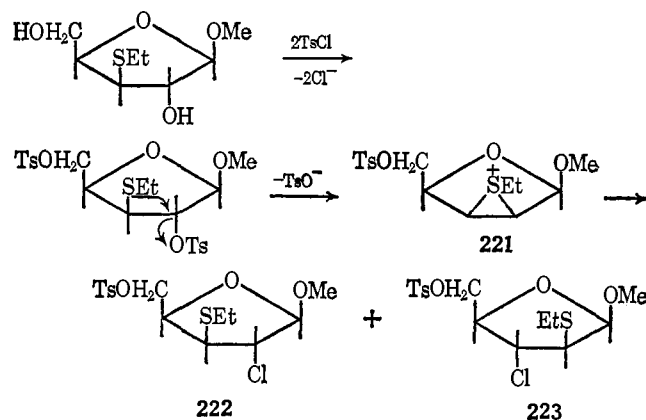

S(5) participation occurs in the reaction of 5-*O*-toluene-*p*-sulfonyl-L-arabinose diethyl dithioacetal in aqueous solution containing barium carbonate which yields a mixture of ethyl 1,5-dideoxy-5-ethylthio-1-mercapto- α - and - β -L-arabinosides.

(627) N. A. Hughes and P. R. H. Speakman, *Chem. Commun.*, 199 (1965); *J. Chem. Soc.*, C, 1182 (1967).

(628) J. G. Buchanan, A. R. Edgar, and D. A. Large, *Chem. Commun.*, 558 (1969).

(629) C. D. Anderson, L. Goodman, and B. R. Baker, *J. Amer. Chem. Soc.*, **81**, 898 (1959).

(630) C. D. Anderson, L. Goodman, and B. R. Baker, *ibid.*, **81**, 3967 (1959).

(631) A. P. Martinez, W. W. Lee, and L. Goodman, *J. Org. Chem.*, **31**, 3263 (1966).

(632) J. E. Christensen and L. Goodman, *J. Amer. Chem. Soc.*, **83**, 3827 (1961).

(633) C. D. Anderson, W. W. Lee, L. Goodman, and B. R. Baker, *ibid.*, **83**, 1900 (1961).

(626) (a) G. R. Gray, F. C. Hartman, and R. Barker, *J. Org. Chem.*, **30**, 2020 (1965); (b) J. S. Brimacombe and O. A. Ching, *Carbohydr. Res.*, **5**, 241 (1967); *J. Chem. Soc.*, C, 1642 (1968); see also J. S. Brimacombe and O. A. Ching, *Chem. Commun.*, 781 (1968); *Carbohydr. Res.*, **8**, 374 (1968).

The first step in this reaction is formation of the cyclic sulfonium ions **224a** and **224b**; these then open to yield ion **225** which is apparently captured exclusively by internal hydroxyl group.¹⁶⁸

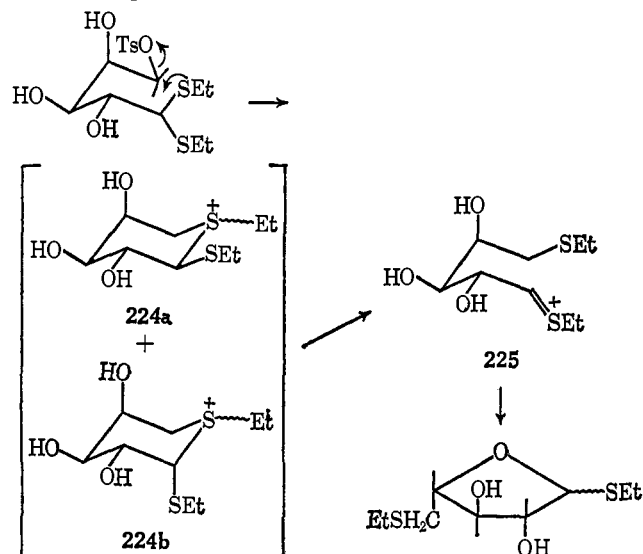

S(5) participation also occurs in the conversion of methyl 1-deoxy-1-mercapto-6-O-toluene-p-sulfonyl-β-D-glucopyranoside into methyl 6-deoxy-6-methyl-thio-α-D-glucopyranoside in neutral methanolic solution (eq 74)⁶³⁴ and

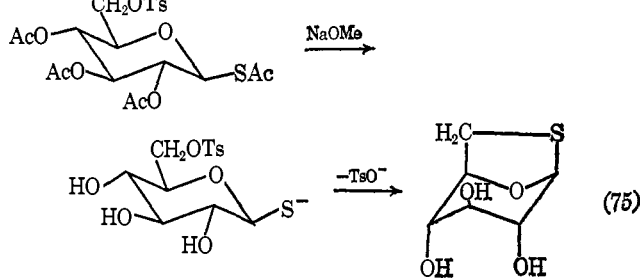
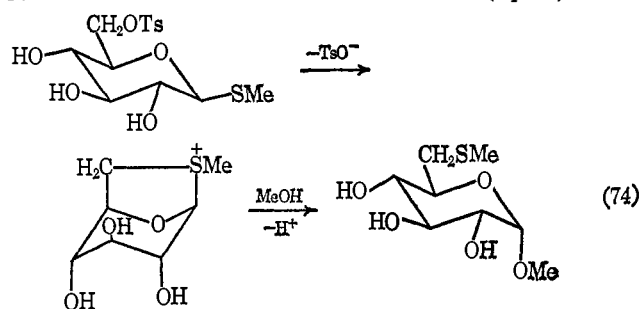

analogous S⁻(5) participation on treatment of 6-O-toluene-p-sulfonyl-2,3,4-tri-O-acetyl-β-D-glucopyranosyl ethyl xanthate

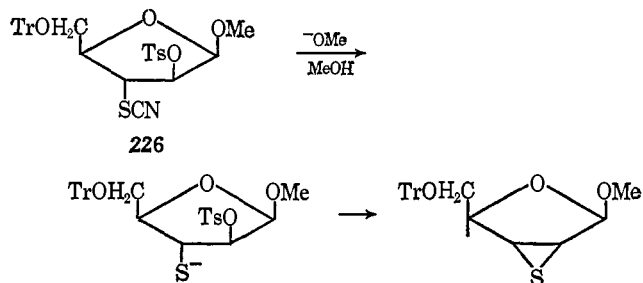

(634) J. C. P. Schwarz, personal communication to the authors of ref 168; E. V. E. Roberts, J. C. P. Schwarz, and C. A. McNab, *Carbohydr. Res.*, 7, 311 (1968).

or thioacetate with sodium methoxide in methanol (eq 75).^{635a} S⁻(3) participation occurs when toluene-p-sulfonate **226** is treated with sodium methoxide in methanol.^{635b}

E. NEIGHBORING GROUP PARTICIPATION BY AMINO GROUP

Few examples of neighboring group participation by amino groups in reactions of sugar derivatives are known, but this apparently occurs on reduction of azide mesylates with Raney nickel and hydrazine when the corresponding aziridines are

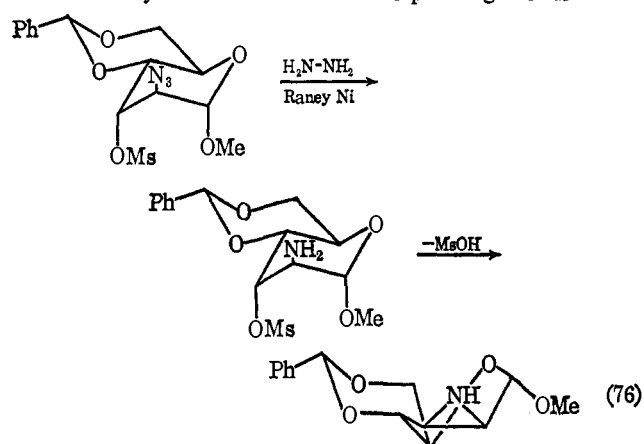

formed (eq 76).^{636, 637a} Aziridines are also formed when pyranose derivatives with benzamido or acetamido and methanesulfonyloxy groups *trans* to one another are treated with lithium aluminum hydride in tetrahydrofuran. It is not clear, however, if reduction occurs before or after participation.^{637b}

F. NEIGHBORING GROUP PARTICIPATION BY ALDEHYDO GROUPS^{632a}

Several examples of participation by the aldehyde group of aldehyde sugars are known. Hughes and Speakman have

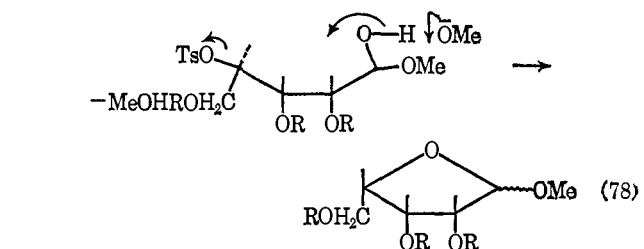
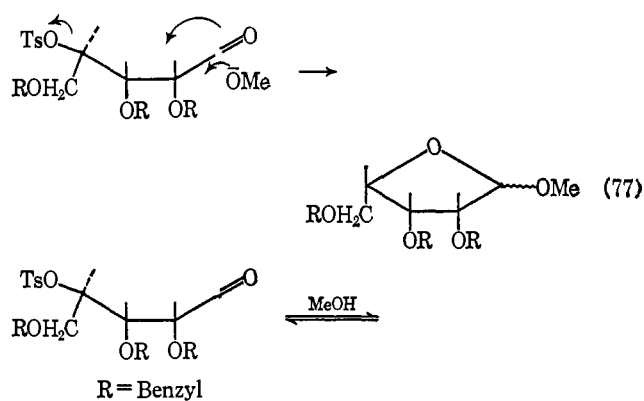

(635) (a) M. Akagi, S. Tejima, and M. Haga, *Chem. Pharm. Bull. (Tokyo)*, 11, 58 (1963); (b) L. Goodman, *Chem. Commun.*, 219 (1968).
 (636) R. D. Guthrie and D. Murphy, *J. Chem. Soc.*, 5288 (1963).
 (637) (a) J. Cléophax, S. D. Gero, and R. D. Guthrie, *Tetrahedron Lett.*, 567 (1967); see also J. Cléophax, S. D. Gero, and J. Hildesheim,

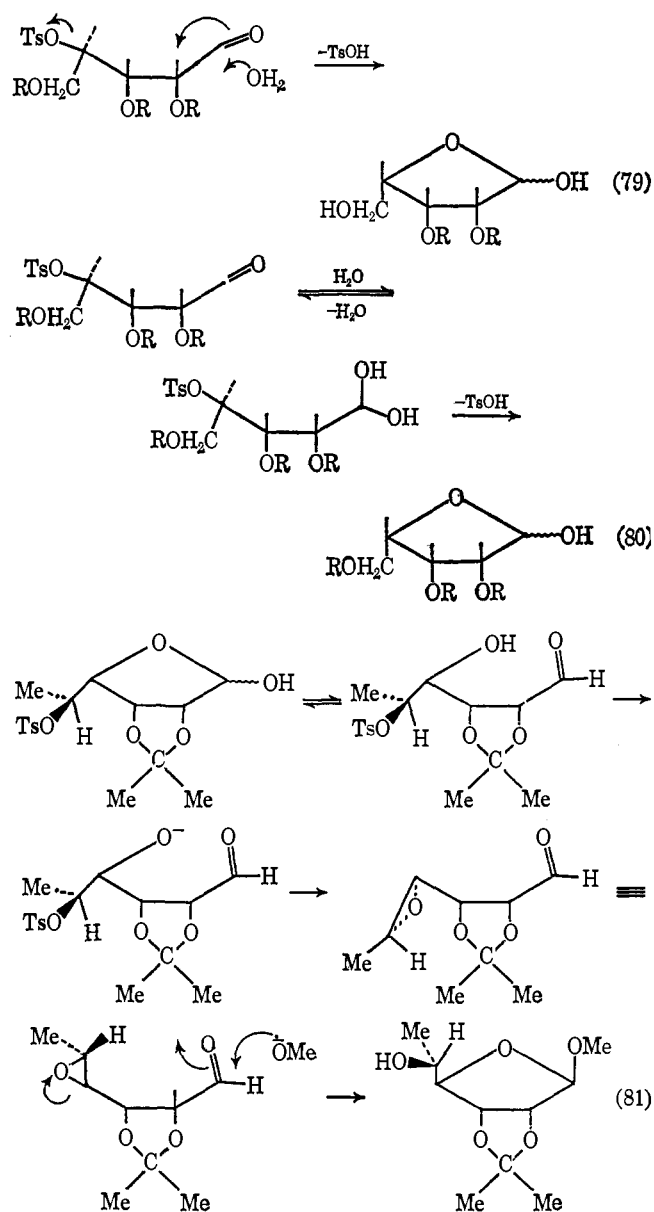

shown that treatment of 2,3,5-tri-*O*-benzyl-4-*O*-toluene-*p*-sulfonylaldehyde-*D*-ribose with sodium methoxide in methanol yields a mixture of methyl *L*-lyxofuranosides.⁶³⁸ Possible mechanisms are shown in eq 77 and 78. A similar reaction occurs if the same aldehyde derivatives, generated by the hydrolysis of the corresponding acetal, is refluxed in 5 *N* sulfuric acid when 2,3,5-tri-*O*-benzyllyxose is formed. Again participation could occur by two pathways (eq 79 or 80). In the reviewer's opinion that of eq 80 is the more likely since the *gem*-diol form is almost certainly the predominant species in aqueous solution.

Successive participation by a hydroxyl and aldehyde group occurs on treatment of 2,3-*O*-isopropylidene-5-*O*-toluene-*p*-sulfonyl-*L*-rhamnofuranose with sodium methoxide when methyl 2,3-*O*-isopropylidene-6-deoxy-*D*-allofuranoside, predominantly of the β configuration, is formed (see eq 81).^{639,640}

Chem. Commun., 94 (1968); (b) A. D. Barford and A. C. Richardson, *Carbohydr. Res.*, 4, 408 (1967); see also ref 643 and 644 below.

(638) N. A. Hughes and P. R. H. Speakman, *J. Chem. Soc., C*, 1186 (1967).

(639) P. A. Levene and J. Compton, *J. Biol. Chem.*, 116, 169 (1936).

(640) E. J. Reist, L. Goodman, R. R. Spencer, and B. R. Baker, *J. Amer. Chem. Soc.*, 80, 3962 (1958); see also J. S. Brimacombe and N. L. C. Tucker, *J. Chem. Soc., C*, 562 (1968); J. S. Brimacombe, F.

G. NEIGHBORING GROUP PARTICIPATION BY AMIDO AND RELATED GROUPS

Neighboring group participation frequently occurs in reactions of sugars having an amido group. As is usual (see ref 641, 642), the ionized amido group tends to react with N participation and the un-ionized amido group with O participation, but sometimes the mode of participation is controlled by conformational, ring-size, or steric effects.

When the amido and leaving groups are *trans*-diaxial, N participation generally predominates under strongly basic conditions. Thus on treatment with sodium ethoxide in ethanol methyl 2-benzamido-4,6-*O*-benzylidene-2-deoxy-3-*O*-methanesulfonyl- α -*D*-altropyranoside (227) yields 56% of aziridine 229 formed *via* its *N*-benzoyl derivative and 25% of oxazoline 228.⁶⁴³ When there is an additional axial substituent on the same side of the ring as the amido group, formation of the five-membered ring with O participation is hindered. For example, the 3-benzamido-2-methanesulfonylaltroside 230 yields only aziridine 231 on treatment with sodium ethoxide in ethanol and no oxazoline.⁶⁴⁴

Participation with N(3) attack can still occur when the neighboring amido and leaving groups are *trans*-diequatorial as in 232, which on treatment with sodium ethoxide yields mainly the aziridine 233.⁶⁴⁴ The analogous β -glucoside 234 yields mainly oxazoline, however.^{645,646} In the absence of kinetic measurements it is difficult to decide if this difference in behavior results from N(3) participation with the β -glucoside being slow owing to difficulty in attaining a boat conformation with the methoxyl and methanesulfonyloxy groups *cis*-diaxial⁶⁴⁴ or from O(5) participation with the α -glucoside being slow owing to hindrance to formation of the fused five-membered ring by the axial methoxyl group.

O participation is favored with the un-ionized amide group even when it and the leaving group are *trans* diaxial and there is another axial group *cis* (cf. eq 82).⁶⁴⁷

Participation by the un-ionized amido group also occurs readily when it and the leaving group are *trans* diequatorial as in the glucose derivative 235,⁶⁴⁸ but surprisingly not with the galactose derivative 236,⁶⁴⁹ although the debenzylidinated compound 237 does react in this way.

All the examples of O participation by an amido group so far described in this review have involved formation of a five-membered ring, but several examples of O(6) participation are also known. Thus, on treatment with sodium benzoate in dimethylformamide, compound 238 reacts as shown in eq 83a.⁶⁵⁰ O(6) participation occurs in the reaction of 2,6-benzamido-2,6-dideoxy-4-*O*-methanesulfonyl-3-*O*-methyl- β -*D*-glucopyranoside with sodium ethoxide in ethanol (eq 83b),^{650b} and successive O(6) and N(5) participation prob-

Hunedy, and L. C. N. Tucker, *ibid.*, 1381 (1968); J. S. Brimacombe and F. Hunedy, *ibid.*, 2701 (1968).

(641) B. Capon, *Quart. Rev.* (London), 18, 71 (1964).

(642) B. Capon, M. J. Perkins, and C. W. Rees, *Org. Reaction Mechanisms*, 55 (1966).

(643) D. H. Buss, L. Hough, and A. C. Richardson, *J. Chem. Soc.*, 5295 (1963).

(644) C. F. Gibbs, L. Hough, and A. C. Richardson, *Carbohydr. Res.*, 1, 290 (1966).

(645) W. Meyer zu Reckendorf and W. A. Bonner, *Chem. Ber.*, 95, 1917 (1962).

(646) W. Meyer zu Reckendorf, *ibid.*, 97, 325 (1964).

(647) B. R. Baker and R. E. Schaub, *J. Org. Chem.*, 19, 646 (1954).

(648) R. W. Jeanloz, *J. Amer. Chem. Soc.*, 79, 2591 (1957).

(649) Z. Tarasiejska and R. W. Jeanloz, *ibid.*, 79, 4215 (1957).

(650) (a) S. Hanessian, *J. Org. Chem.*, 32, 163 (1967); (b) W. Meyer zu Reckendorf, *Chem. Ber.*, 96, 2019 (1963); (c) J. S. Brimacombe and J. G. H. Bryan, *Carbohydr. Res.*, 6, 423 (1968).

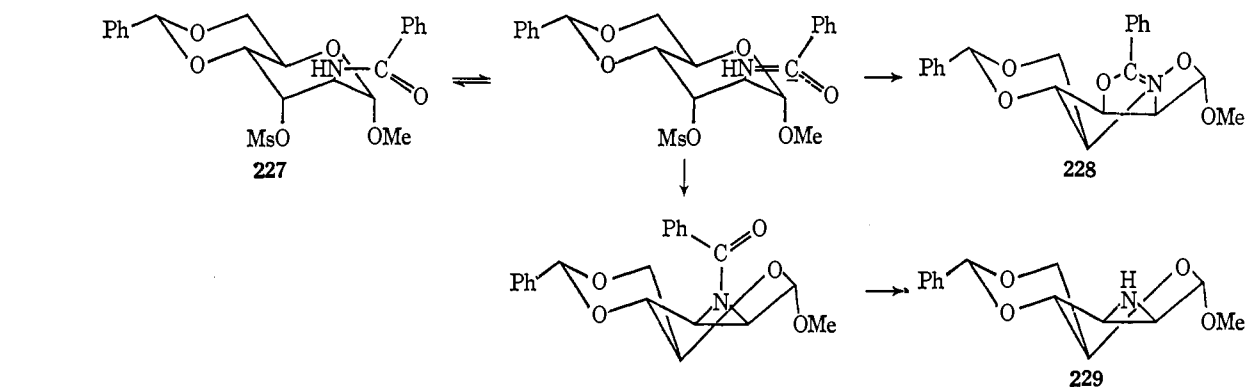

mino)-3,6-dideoxy-1,2-*O*-isopropylidene- β -L-idofuranose (see eq 83c).⁶⁵⁰ It is interesting that in the second stage of this transformation N(5) participation apparently occurs in preference to O(7) participation.

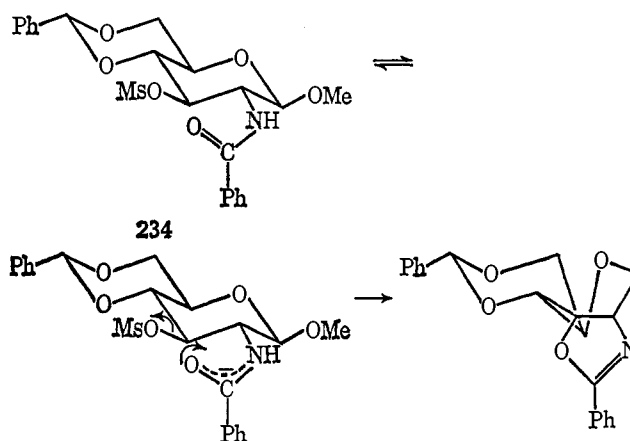
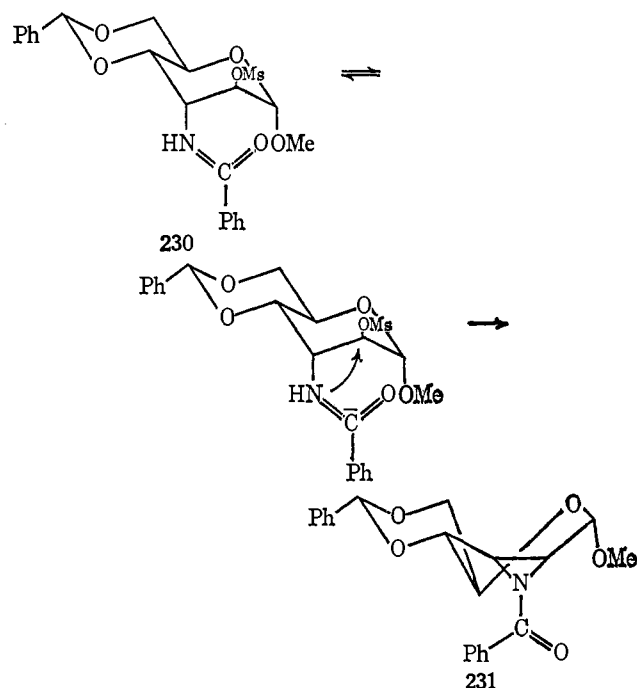

Other examples of neighboring group participation by amide groups attached to pyranose and furanose rings are described in ref 651-653.

ably occur in the solvolysis in buffered 2-methoxymethanol of 3-acetamido-3-deoxy-1,2-*O*-isopropylidene-5,6-di-*O*-methanesulfonyl- α -D-glucufuranose to yield 3,6-(acetylepi-

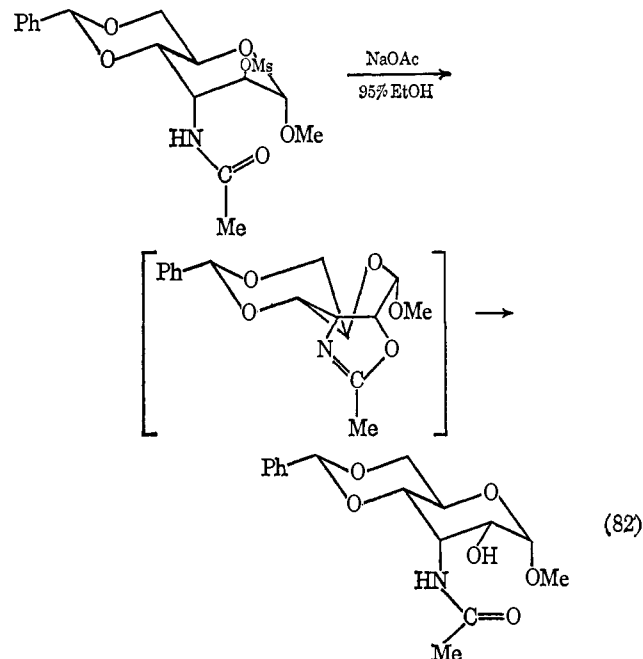
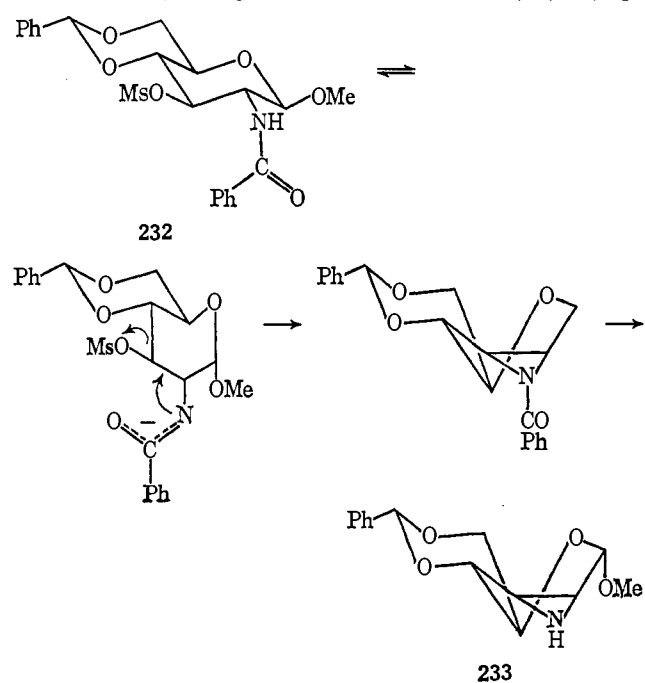

(651) W. Meyer zu Reckendorf and W. A. Bonner, *Tetrahedron*, **19**, 1711 (1963).

(652) B. R. Baker, R. E. Schaub, and J. H. Williams, *J. Amer. Chem. Soc.*, **77**, 7 (1955).

(653) B. R. Baker and R. E. Schaub, *ibid.*, **77**, 2396 (1955).

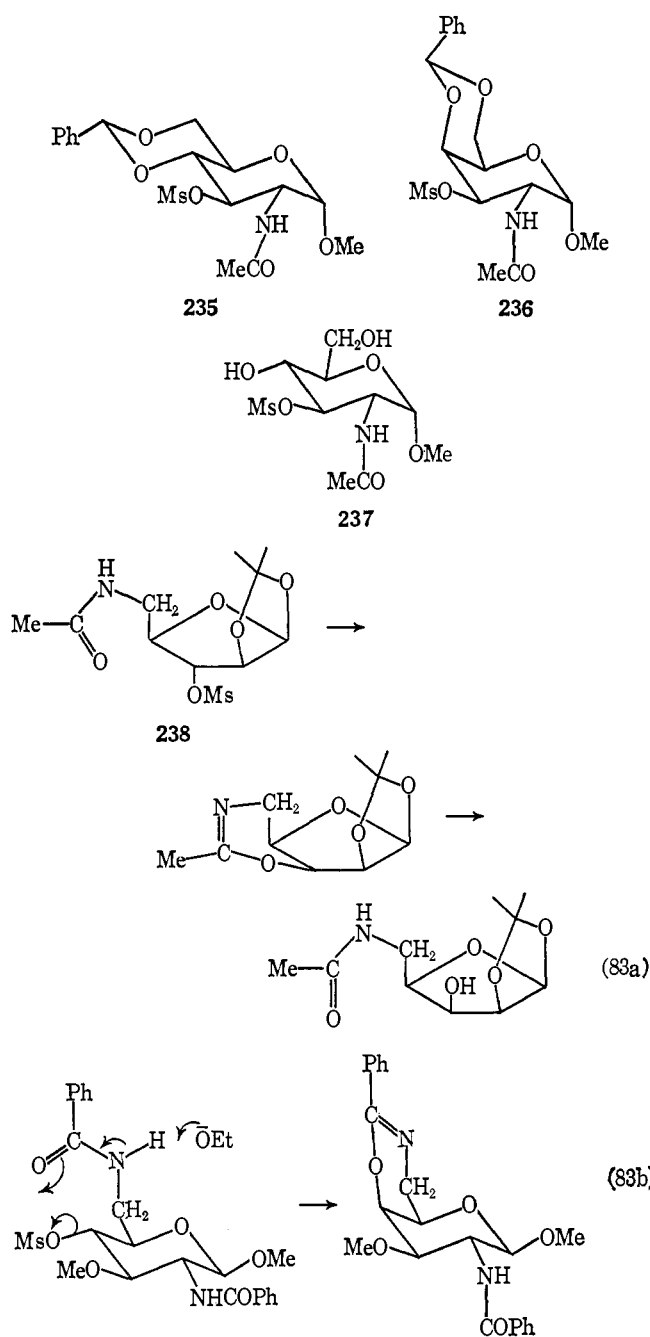

The same general pattern of behavior as described here for participation by the amido group is also found with participation by the dithiocarbamoyl group (eq 84,^{654,655} see also ref 656), the thioureido group (eq 85–88),^{657–659} and the ureido group.^{658–660} S participation by a dithiocarbamoyl group which is directly bonded by one of its sulfurs to the sugar ring is described in ref 660b.

N-(5) participation by an ureido group⁶⁶¹ and by a phenyl-

(654) J. E. Christensen and L. Goodman, *J. Amer. Chem. Soc.*, **82**, 4738 (1960).

(655) L. Goodman and J. E. Christensen, *ibid.*, **83**, 3823 (1961).

(656) W. Meyer zu Reckendorf and W. A. Bonner, *Tetrahedron*, **19**, 1721 (1963).

(657) B. R. Baker and T. R. Neilson, *J. Org. Chem.*, **29**, 1051 (1964).

(658) B. R. Baker and T. R. Hullar, *ibid.*, **30**, 4038 (1965).

(659) B. R. Baker and T. L. Hullar, *ibid.*, **30**, 4045 (1965).

(660) (a) B. R. Baker and T. Neilson, *ibid.*, **29**, 1057 (1964); (b) S. Ishiguro and S. Tejima, *Chem. Pharm. Bull. (Tokyo)*, **16**, 1567, 2040 (1968).

(661) B. R. Baker and T. L. Hullar, *J. Org. Chem.*, **30**, 4053 (1965).

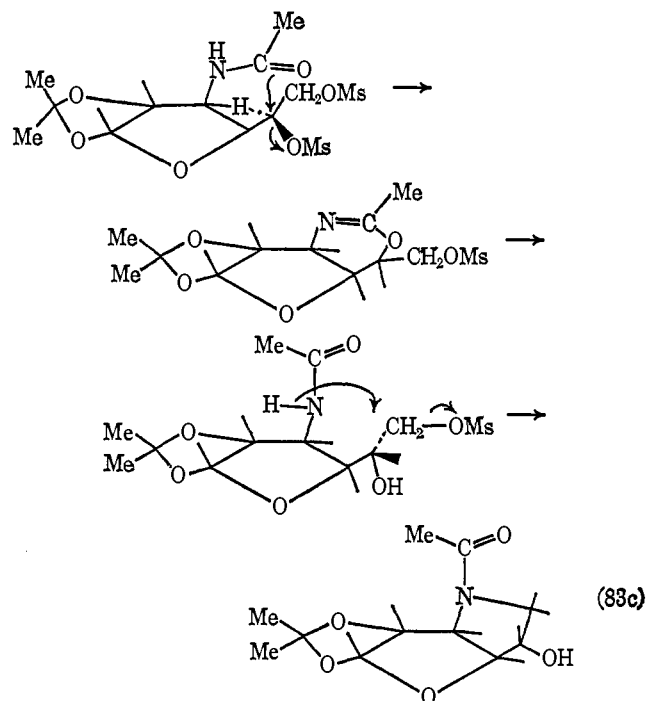

thiocarbamoyl group⁶⁶² (see also ref 663) occurs when compounds **239** and **240a** are treated with sodium methoxide in methanol. In contrast, on treatment with thionyl chloride, compound **240b** reacts with sulfur participation.

Unlike in the acyclic series (eq 89) N(5) participation by the nitroguanidino group does not occur readily with the altrose derivative **241**. In pyridine there is no reaction, and with sodium ethoxide the aziridine **242** is formed.⁶⁶⁴ N(5) participation by the guanidino occurs rapidly, however, and **243** cyclizes as rapidly as it is formed from the corresponding hydroxy compound and methanesulfonyl chloride in pyridine.⁶⁶⁵

Only N-(3) participation occurs with sulfamido groups under basic conditions. Reaction is rapid when the participating and leaving groups are diaxial but slow when they are diequatorial (eq 90).⁶⁶⁶ Similar participation in furanose rings occurs quite rapidly (eq 91).⁶⁶⁷

H. NEIGHBORING GROUP PARTICIPATION BY ACYLOXY GROUPS

Although participation by neighboring acyloxy groups in the displacement of sulfonate groups attached to pyranose rings occurs only with difficulty (*cf.* ref 667), several examples are now known. The preferred reagent is sodium benzoate or sodium fluoride in dimethylformamide and the resulting acyloxonium ion generally opens to yield *cis*-hydroxy esters.^{668–671} This last stage apparently occurs in the dimethylformamide and not on "work-up" as two successive participations by the same benzoate group occur when methyl 2-*O*-benzoyl-3,4-di-

(662) B. R. Baker, K. Hewson, L. Goodman, and A. Benitez, *J. Amer. Chem. Soc.*, **80**, 6577 (1958).

(663) L. Goodman, A. Benitez, C. D. Andersen, and B. R. Baker, *ibid.*, **80**, 6582 (1958).

(664) B. R. Baker and T. Neilson, *J. Org. Chem.*, **29**, 1047 (1964).

(665) B. R. Baker and T. Neilson, *ibid.*, **29**, 1063 (1964).

(666) B. R. Baker and T. L. Hullar, *ibid.*, **30**, 4049 (1965).

(667) B. R. Baker and A. H. Haines, *ibid.*, **28**, 438 (1963).

(668) E. M. Acton, K. J. Ryan, and L. Goodman, *J. Amer. Chem. Soc.*, **86**, 5352 (1964).

(669) E. J. Reist, D. F. Calkins, and L. Goodman, *Chem. Ind. (London)*, 1561 (1965).

(670) E. J. Reist, L. V. Fisher, and D. E. Gueffroy, *J. Org. Chem.*, **31**, 226 (1966).

(671) E. J. Reist, D. F. Calkins and L. Goodman, *ibid.*, **32**, 169 (1967).

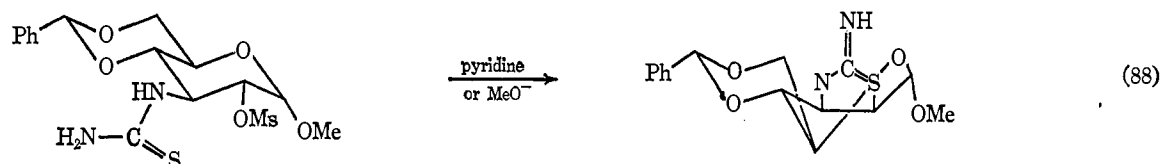
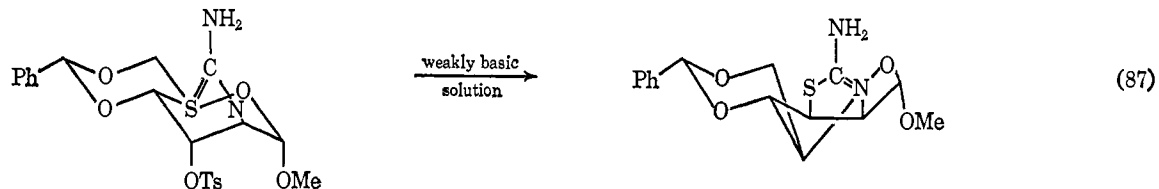
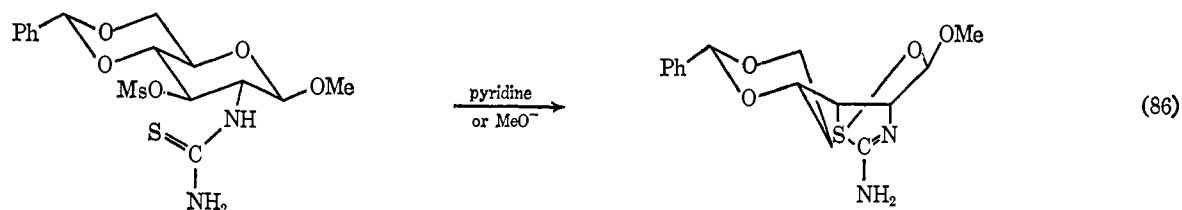
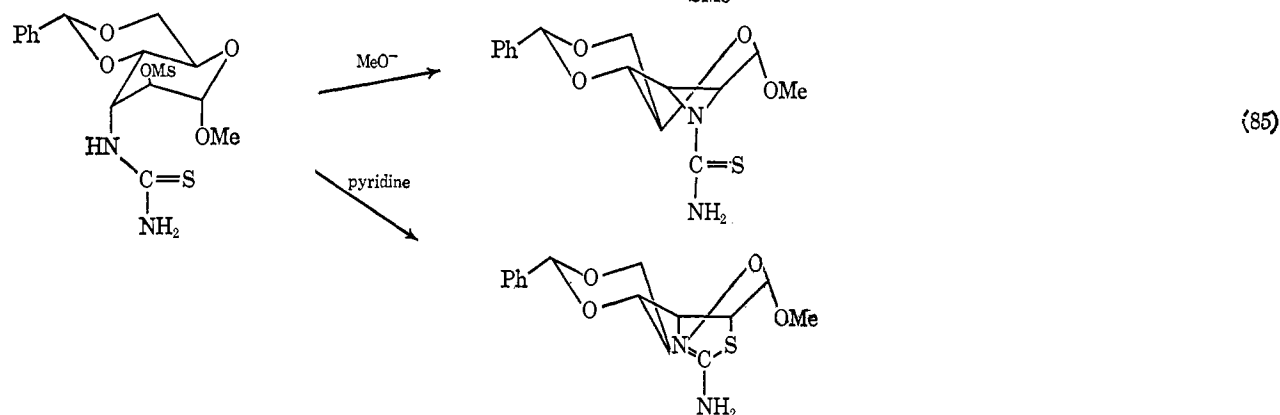
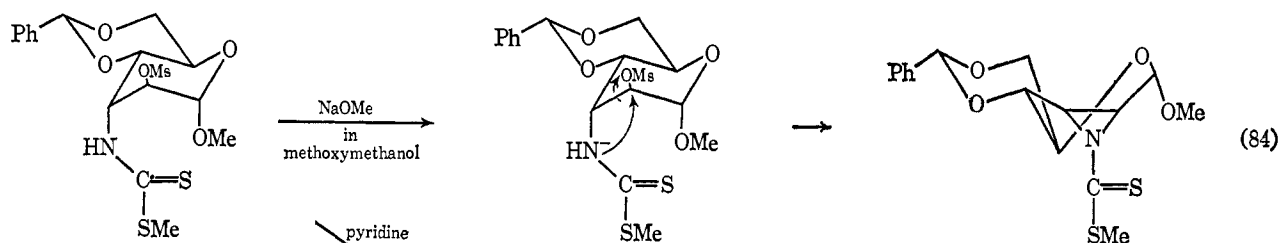

O-toluene-*p*-sulfonyl- β -L-arabinoside is heated with sodium fluoride in dimethylformamide.⁶⁷⁰ The product, which contained no sulfonate groups, yielded after debenzoylation mainly methyl α -D-ribofuranoside, and the reaction must have proceeded as shown in eq 92. The function of the sodium fluoride is not clear; possibly it acts as a buffer or possibly the fluoride ion acts as a gegenion stabilizing the acyloxonium ion or even forming a covalent ortho ester fluoride. Hydrolysis to the hydroxy ester is presumably brought about by adventitious traces of water.

Thioacyl groups appear to provide much more anchimeric assistance than acyl groups. The evidence for this is that whereas only the toluene-*p*-sulfonyloxy group at C(4) of methyl

2-*O*-benzoyl-3,4-di-*O*-toluene-*p*-sulfonyl- β -L-arabinopyranoside is replaced on treatment with sodium benzoate in dimethylformamide, both groups are replaced on treatment with sodium thiolbenzoate. It was suggested that the toluene-*p*-sulfonyloxy group at C(4) was displaced first and then that at C(3) was displaced with participation by the resulting thioester group to yield a thioacyliminium ion **244**. Ring opening of this by attack at C(4) and rearrangement of the resulting thionbenzoate then yielded thiol benzoate **245**, the whole process occurring as shown in eq 93.^{672a} Formation of **245**

(672) (a) E. J. Reist, L. V. Fisher, D. E. Gueffroy, and L. Goodman, *J. Org. Chem.*, **31**, 1506 (1966); (b) E. M. Acton, K. J. Ryan, and L. Goodman, *J. Amer. Chem. Soc.*, **89**, 467 (1967); *J. Org. Chem.*, **33**, 1783 (1968); (c) K. J. Ryan, E. M. Acton, and L. Goodman, *ibid.*, **33**, 3727 (1968).

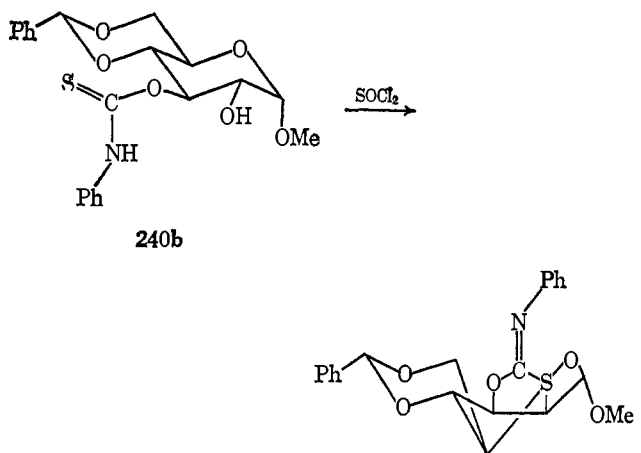
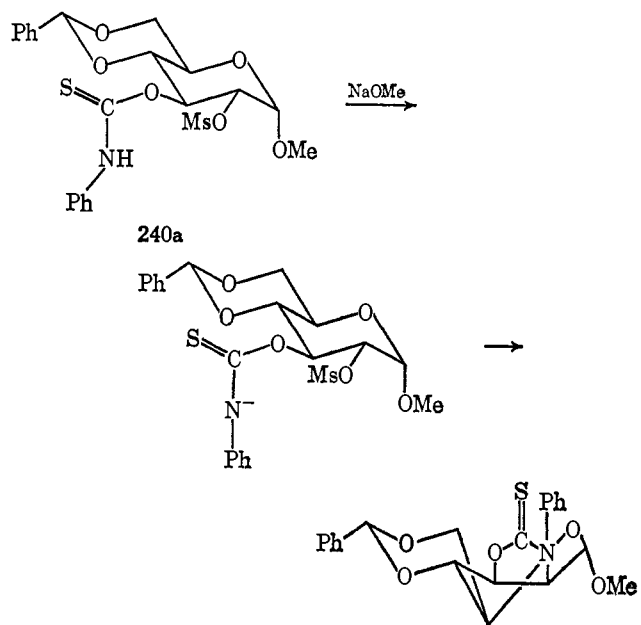
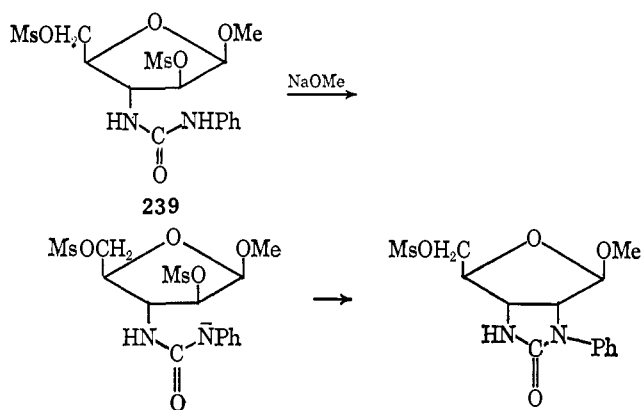

could also be explained if there were S(3) participation by the thio ester group rather than O(5) participation. S(3) participation has recently been demonstrated to occur with an S-benzoyl group attached to a furanose ring to the exclusion of O(5) participation.^{67,20}

Participation by a thionbenzoate group has also been reported. Treatment of compound **246** with sodium benzoate in dimethylformamide results in displacement of the primary toluene-*p*-sulfonyl group by an S_N2 displacement and of the secondary one with participation by the thionbenzoate group. The product was the dimer thought to arise from condensation

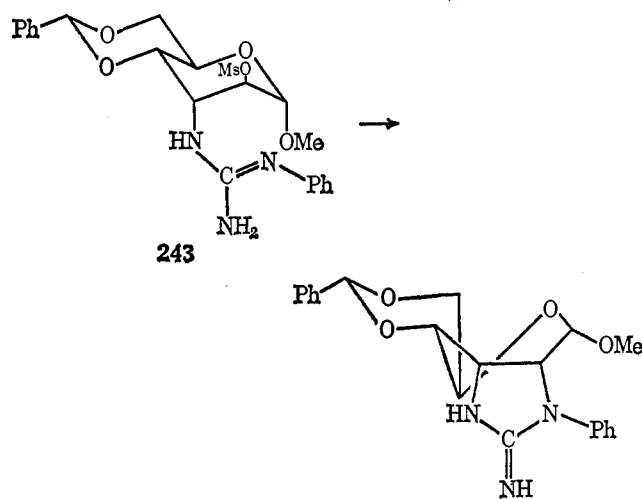
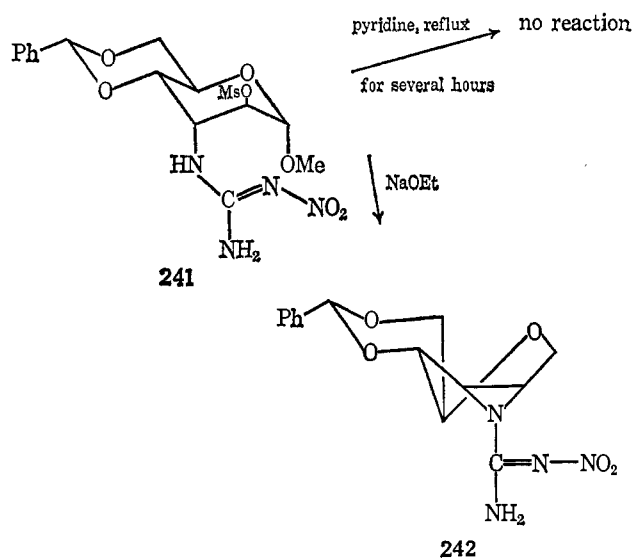
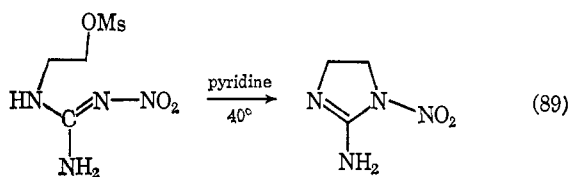

of ion **247** with thiol **248** formed from **247** and traces of moisture^{67,2b}

Participation by a benzoyl group in a displacement reaction on a furanose ring has been investigated by Ness who showed that whereas 1,3,5-tri-*O*-benzoyl-2-*O*-nitrobenzene-*p*-sulfonyl- α -D-ribose did not react with sodium benzoate in molten benzoic acid, its β anomer yielded α -D-arabinofuranose tetraacetate.^{67a} Treatment of the β anomer with sodium *p*-nitrobenzoate in *N,N*-dimethylformamide yielded 2,3,5-tri-*O*-benzoyl-1-*O*-*p*-nitrobenzoyl- α -D-arabinose and treatment of 3,5-di-*O*-benzoyl-2-*O*-nitrobenzene-*p*-sulfonyl-1-*O*-(*p*-nitrobenzyl)- β -D-ribose with sodium benzoate in molten benzoic acid yielded 1,3,5-tri-*O*-benzoyl-2-*O*-(*p*-nitrobenzoyl)- α -D-arabinose. Neighboring group participation as shown in eq 94 was therefore proposed.

Participation also occurs in reactions of furanose derivatives in dimethylformamide solution. Thus treatment of methyl 2-*O*-benzoyl-5-deoxy-3-*O*-methanesulfonyl- α,β -D-xylofuranoside with sodium benzoate in dimethylformamide yields

(673) R. K. Ness, *J. Org. Chem.*, 27, 1155 (1962).

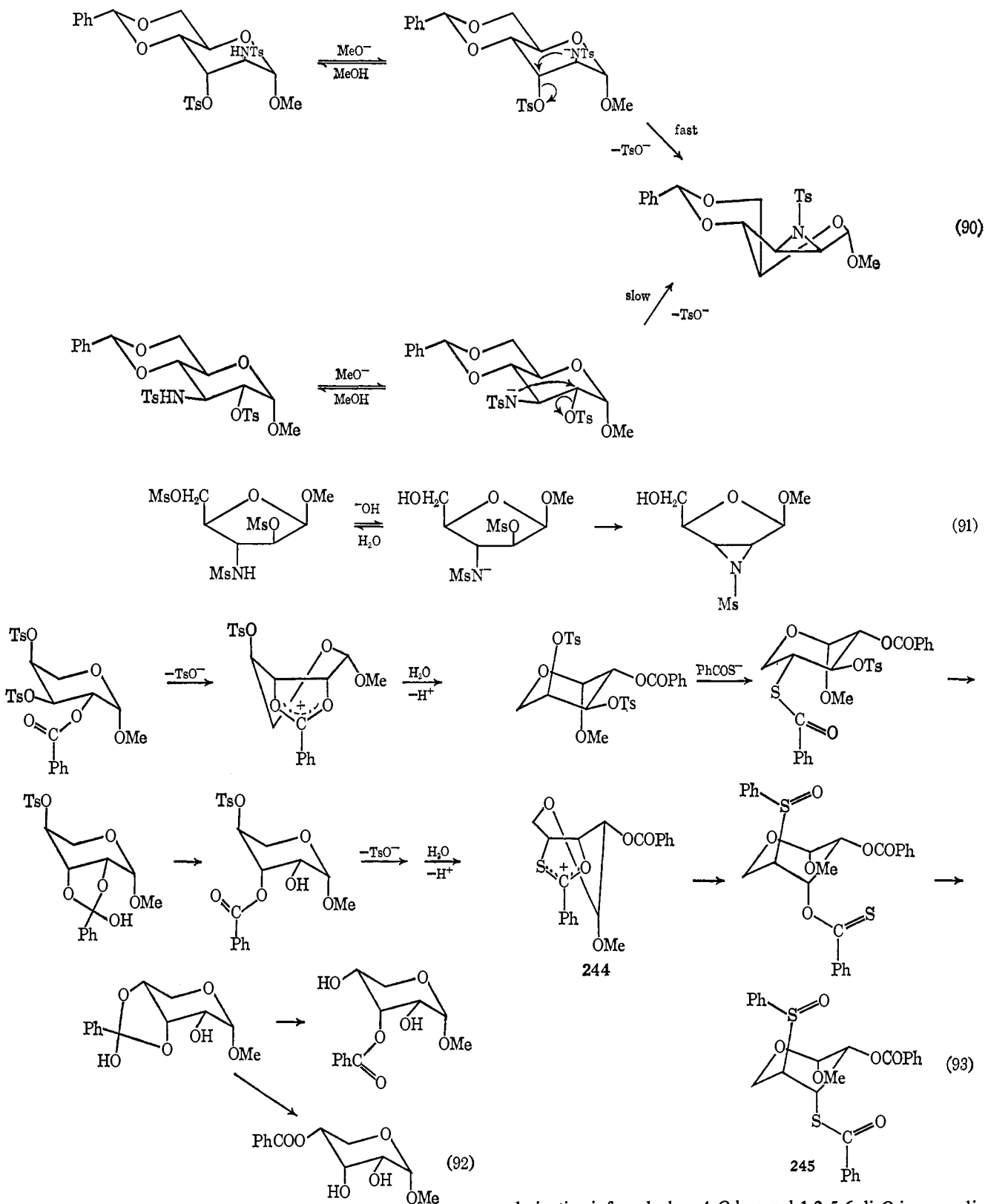

a mixture of monobenzoates of methyl 5-deoxy- α - and - β -ribofuranosides. Participation as shown in eq 95 is indicated by the nonformation of dibenzoates and the fact that the reaction occurs much more rapidly than that of the analogous 2-*O*-benzyl derivatives.⁶⁷⁴

An example of participation in the reaction of an acyclic

(674) K. J. Ryan, H. Arzoumanian, E. M. Acton, and L. Goodman, *J. Amer. Chem. Soc.*, **86**, 2497, 2503 (1964).

derivative is found when 4-*O*-benzoyl-1,2:5-6-di-*O*-isopropylidene-3-*O*-methanesulfonyl-*D*-mannitol is treated with sodium acetate in dimethylformamide containing 0.5% water to yield a mixture of the monobenzoates of 1,2:5-6-di-*O*-isopropylidene-*D*-talitol (eq 96). Competition by an $\text{S}_{\text{N}}2$ displacement by acetate occurred under the conditions used to the extent of

(675) M. A. Bukhari, A. B. Foster, J. Lehmann, M. H. Randall, and J. M. Webber, *J. Chem. Soc.*, 4167 (1963).

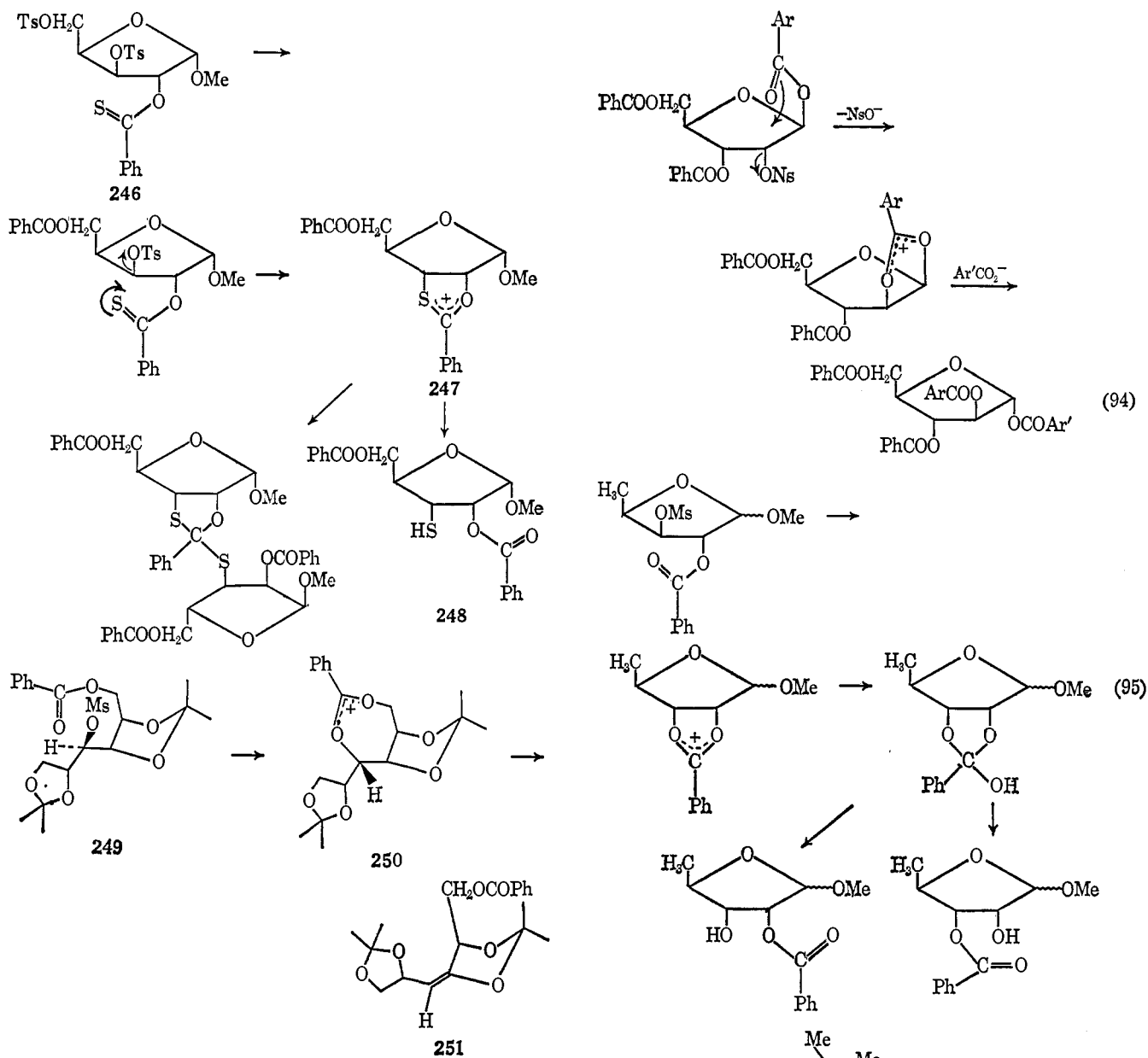

only 10%⁶⁷⁷ (see also ref 675). In the presence of azide ion the $\text{S}_{\text{N}}2$ reaction predominates, however.⁶⁷⁶

Participation by an acyloxy group to give a seven-membered cyclic ion possibly occurs in the conversion of 6-*O*-benzoyl-1,2:4,5-di-*O*-isopropylidene-3-*O*-methanesulfonylmannitol (**249**) into the enol ether (**251**) for which ion **250**, with a geometry suitable for elimination, was suggested as an intermediate.⁶⁷⁷

Participation by acetoxy groups appears to occur more readily in the opening of epoxide rings than in the displacement of sulfonate esters. An example is found in the reaction of methyl 2-*O*-acetyl-3,4-anhydro- α -D-altroside (**252**) in aqueous acetic acid which yields the mannose derivative **254** almost exclusively. In the absence of participation predominant formation of the idose derivative **253** would be expected through diaxial ring opening, similar to that found with the unacetylated epoxide⁶⁷⁸ (see also ref 679).

(676) B. R. Baker and A. H. Haines, *J. Org. Chem.*, **28**, 442 (1963).

(677) M. A. Bukhari, A. B. Foster, J. M. Webber, and J. Lehmann, *Carbohydr. Res.*, **1**, 485 (1966).

(678) J. G. Buchanan and J. C. P. Schwarz, *J. Chem. Soc.*, 4770 (1962).

(679) J. G. Buchanan, *ibid.*, 2511 (1958).

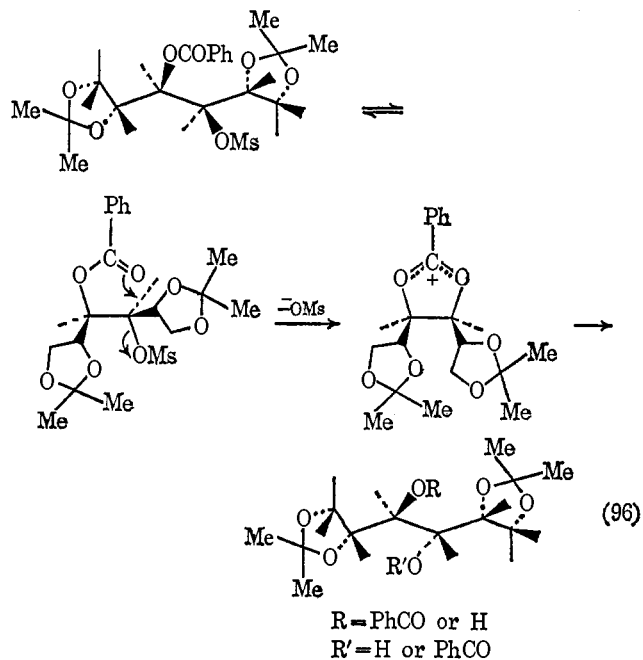

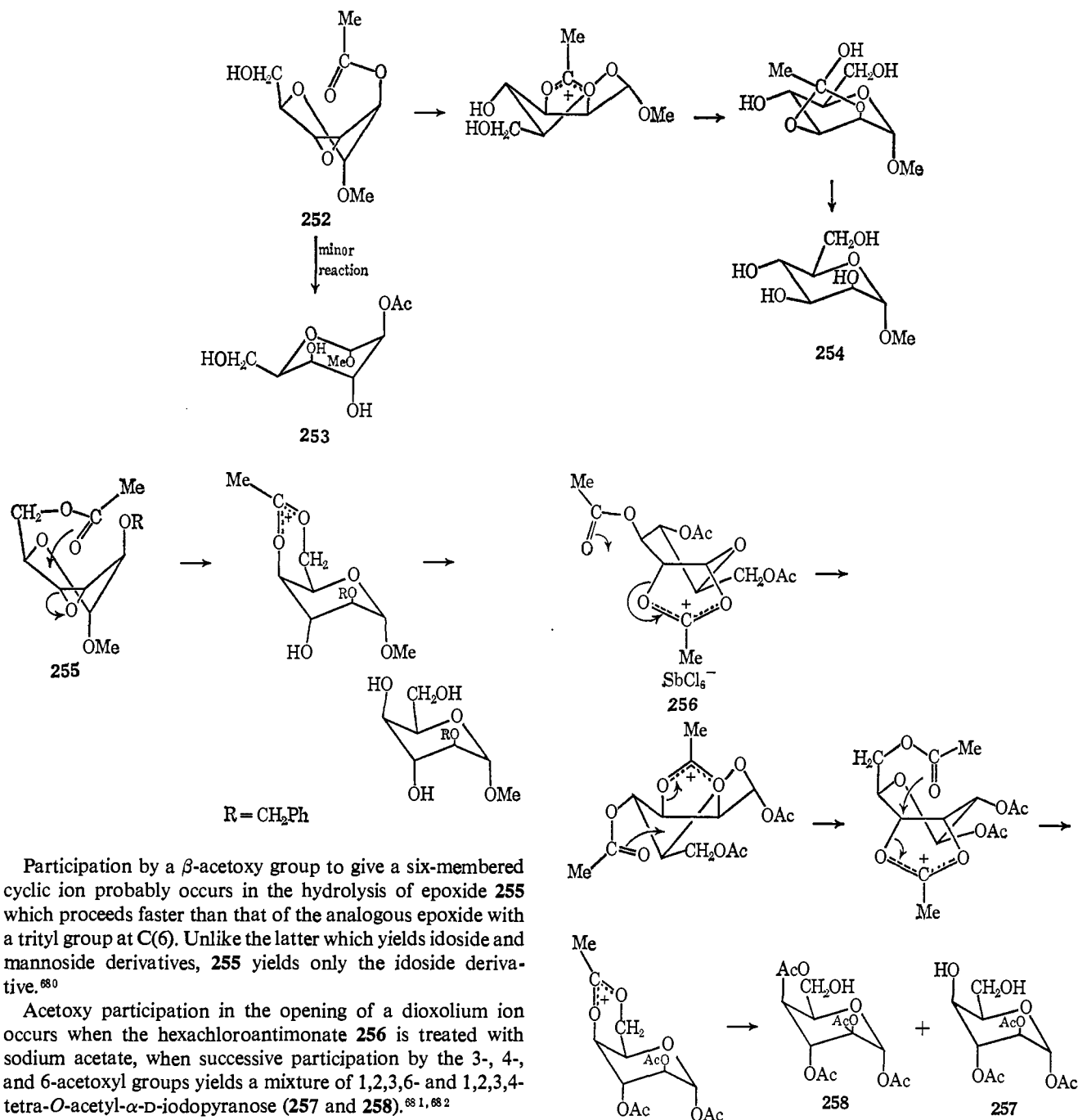

Participation by a β -acetoxy group to give a six-membered cyclic ion probably occurs in the hydrolysis of epoxide **255** which proceeds faster than that of the analogous epoxide with a trityl group at C(6). Unlike the latter which yields idoside and mannoside derivatives, **255** yields only the idoside derivative.⁶⁸⁰

Acetoxy participation in the opening of a dioxolium ion occurs when the hexachloroantimonate **256** is treated with sodium acetate, when successive participation by the 3-, 4-, and 6-acetoxy groups yields a mixture of 1,2,3,6- and 1,2,3,4-tetra-O-acetyl- α -D-iodopyranose (**257** and **258**).^{681, 682}

Similar successive participation is found in the conversions of 6-chlorohexaacetyl- α -D-hexoses into mixtures of several heptaacetyl- α -D- and -L-hexoses on treatment with zinc chloride and acetic anhydride,⁶⁸³⁻⁶⁸⁵ and in the interconversion of cyclitol and sugar esters on treatment with liquid hydrogen

fluoride⁶⁸⁶⁻⁶⁹⁷ or 95% acetic acid containing 1.5% sulfuric acid.^{698, 699}

(680) J. G. Buchanan and R. M. Saunders, *J. Chem. Soc.*, 1791 (1964).

(681) H. Paulsen, W.-P. Trautwein, F. Garrido-Espinosa, and K. Heyns, *Tetrahedron Lett.*, 4131, 4137 (1966).

(682) H. Paulsen, W.-P. Trautwein, F. G. Espinosa, and K. Heyns, *Chem. Ber.*, 100, 2822 (1967); see also H. Paulsen, F. G. Espinosa, W.-P. Trautwein, and K. Heyns, *ibid.*, 101, 179 (1968); H. Paulsen, F. G. Espinosa, and W.-P. Trautwein, *ibid.*, 101, 186 (1968); F. G. Espinosa, W.-P. Trautwein, and H. Paulsen, *ibid.*, 101, 191 (1968).

(683) F. Micheel and R. Böhm, *ibid.*, 98, 1659 (1965).

(684) F. Micheel, H. Pfetzing, and G. Pirke, *Carbohydr. Res.*, 3, 283 (1967).

(685) F. Micheel and E. Matzke, *ibid.*, 4, 249 (1967).

(686) C. Pedersen and H. G. Fletcher, *J. Amer. Chem. Soc.*, 82, 941 (1960).

(687) C. Pedersen and H. G. Fletcher, *ibid.*, 82, 945 (1960).

(688) E. J. Hedgley and H. G. Fletcher, *ibid.*, 84, 3726 (1962).

(689) E. J. Hedgley and H. G. Fletcher, *ibid.*, 85, 1615 (1963).

(690) E. J. Hedgley and H. G. Fletcher, *ibid.*, 86, 1576 (1964).

(691) E. J. Hedgley and H. G. Fletcher, *ibid.*, 86, 1583 (1964).

(692) C. Pedersen, *Acta Chem. Scand.*, 16, 1831 (1962).

(693) C. Pedersen, *ibid.*, 18, 60 (1964).

(694) I. Lundt, C. Pedersen, and B. Tronier, *ibid.*, 18, 1917 (1964).

(695) C. Pedersen, *ibid.*, 20, 963 (1966); 22, 1888 (1968); N. Gregersen and C. Pedersen, *ibid.*, 22, 1307 (1968).

(696) C. Pedersen, *Tetrahedron Lett.*, 511 (1967).

(697) I. Lundt and C. Pedersen, *Acta Chem. Scand.*, 21, 1239 (1967).

(698) S. J. Angyal, P. A. J. Gorin, and M. Pitman, *Proc. Chem. Soc.*, 337 (1962).

(699) S. J. Angyal, P. A. J. Gorin, and M. E. Pitman, *J. Chem. Soc.*, 1807 (1965).

I. NEIGHBORING GROUP PARTICIPATION BY THE HETEROCYCLIC RINGS OF NUCLEOSIDES

Although anhydro⁷⁰⁰ or cyclo⁷⁰¹ nucleosides have been studied extensively in recent years, there have been few quantitative investigations of the kinetics of their formation. Nevertheless, the large amount of qualitative data that is now available enables several interesting generalizations to be made.

Participation by pyrimidine rings has been most widely studied and, as would be expected, the anchimeric assistance provided by the cytosine ring is greater than that provided by the less basic uracil. Thus, on heating in acetone, 5'-*O*-toluene-*p*-sulfonyl-2',3'-*O*-isopropylidencytidine (**259**) yields the anhydronucleoside **260**, but the analogous uridine derivative does not react.⁷⁰² However, in the presence of base (e.g., KO*Bu-t*), participation by the ionized uracil (pK_a of uridine = 9.17 in water) occurs rapidly (see eq 97).⁷⁰³

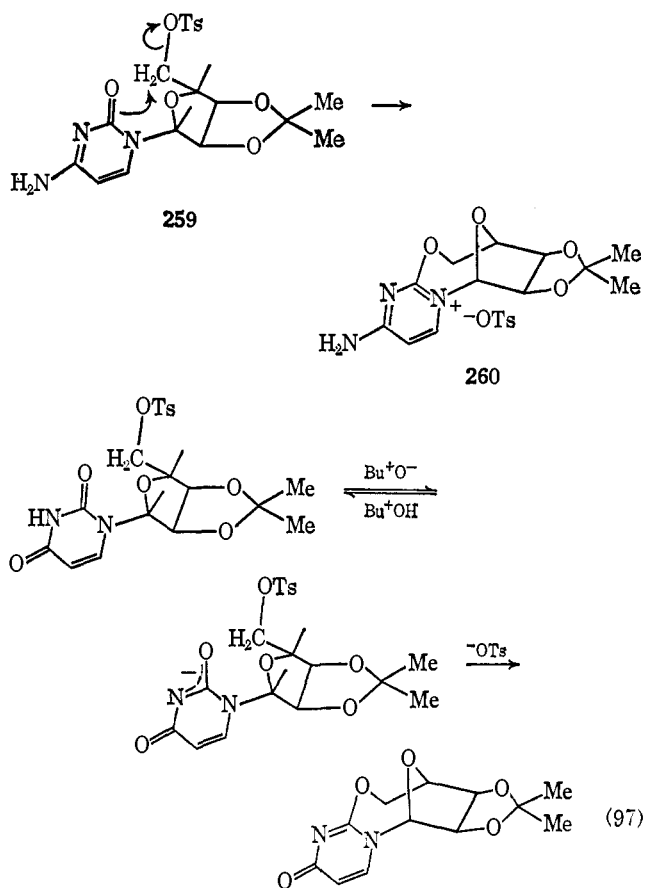

These reactions involve formation of a seven-membered ring, or more strictly of a bicyclo[4.2.1] system. Analogous displacements at positions 3' or 2' would result in formation of six- and five-membered rings (bicyclo[3.2.1] or -[3.3.0] systems), and these occur much more readily, with the latter the most

favored. Thus 3',5'-di-*O*-methanesulfonylthymidine (**261**) with alcoholic ammonia and 3',5'-di-*O*-methanesulfonyl- β -D-arabinofuranosyluracil (**262**) with boiling water yield 2,3'-anhydro derivatives,^{704,705} and tri-*O*-methanesulfonyluridine (**263**) with sodium hydroxide in aqueous ethanol yields the 2,2'-anhydronucleoside.⁷⁰⁶ In contrast to the ease with which these reactions occur, participation in displacement reactions at position 3' of uridine only occurs with difficulty, as illus-

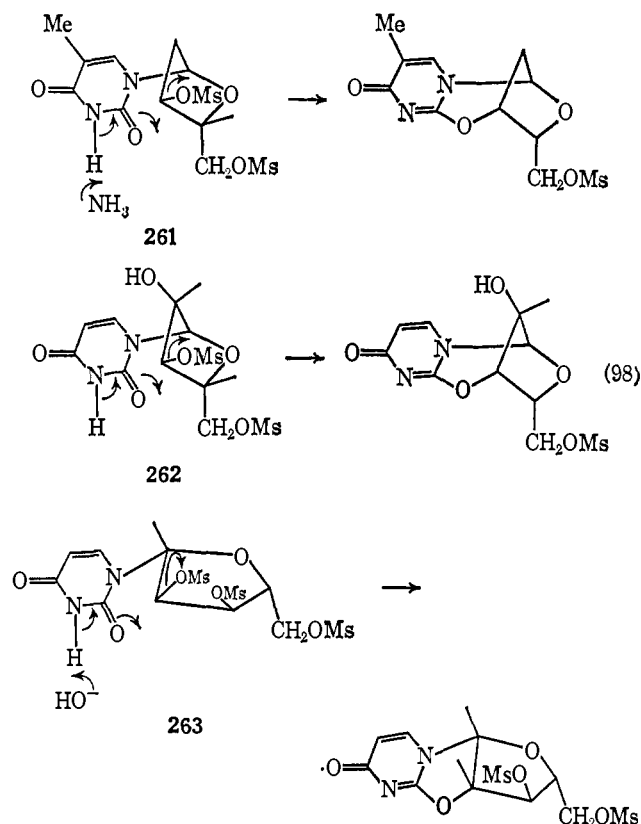

trated by 3'-*O*-methanesulfonyl- and 3'-*O*-toluene-*p*-sulfonyluridine not reacting with aqueous sodium hydroxide or with boiling water,^{707,708} although the latter compound does give some 2,3'-anhydrouridine with sodium *t*-butoxide in dimethylformamide.⁷⁰⁹ The reason for this lack of reactivity is not understood.

The cytosine ring provides more anchimeric assistance than the un-ionized uracil ring for substitution at position 2', as shown by the observation that the fluorocytidine **264** reacts 29 times more rapidly than the fluorouridine **266** in boiling water, pH 5–6. Under these conditions the resulting 2,2'-anhydrocytidine is unstable and undergoes ring opening to yield arabinofuranosylcytosine (**265**), but the anhydrouridine **267** is stable.⁷¹⁰

Participation also occurs with the N(4)-acylamino derivatives of cytidine, **268a** and **268b**, which are converted very

(700) J. J. Fox and I. Wempen, *Advan. Carbohydr. Chem.*, **14**, 283 (1959).

(701) A. M. Michelson, "The Chemistry of Nucleosides and Nucleotides," Academic Press, New York, N. Y., 1963, p 15.

(702) V. M. Clark, A. R. Todd, and J. Zussman, *J. Chem. Soc.*, 2952 (1951).

(703) (a) See A. M. Michelson, ref 701, pp 18–19. Analogous participation by a quinazoline-2,4-dione ring has been reported recently: M. G. Stout and R. K. Robins, *J. Org. Chem.*, **33**, 1219 (1968); (b) S. S. Tang and J. S. Roth, *Tetrahedron Lett.*, 2123 (1968).

(704) A. M. Michelson and A. R. Todd, *J. Chem. Soc.*, 816 (1955); see also R. Duschinsky and U. Eppenberger, *Tetrahedron Lett.*, 5103 (1967).

(705) R. Fecher, J. F. Codington, and J. J. Fox, *J. Amer. Chem. Soc.*, **83**, 1889 (1961).

(706) J. F. Codington, R. Fecher, and J. J. Fox, *ibid.*, **82**, 2794 (1960).

(707) N. C. Yung and J. J. Fox, *ibid.*, **83**, 3060 (1961).

(708) D. M. Brown, D. B. Parihar, A. R. Todd, and S. Varadarajan, *J. Chem. Soc.*, 3028 (1958).

(709) R. Letters and A. M. Michelson, *ibid.*, 1410 (1961).

(710) I. L. Doerr and J. J. Fox, *J. Org. Chem.*, **32**, 1462 (1967).

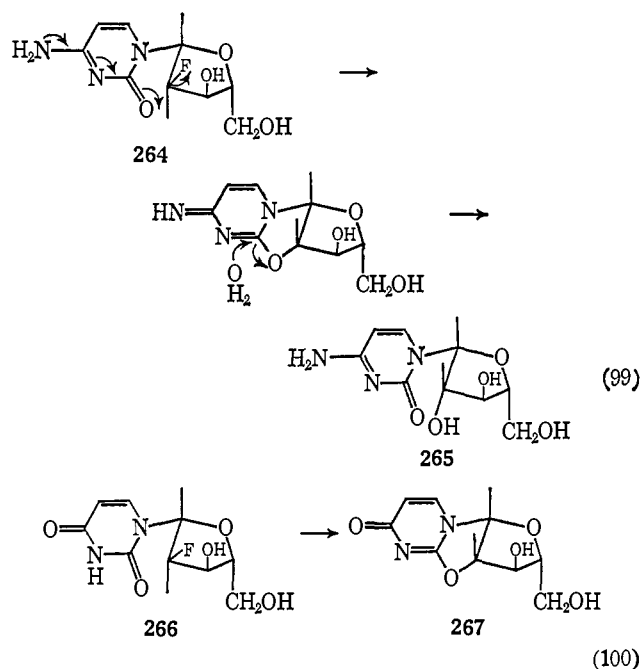

readily into arabinosylcytosines, presumably *via* anhydronucleosides **269a** and **269b**, which could not be detected and must therefore undergo ring opening faster than they are formed.⁷¹¹

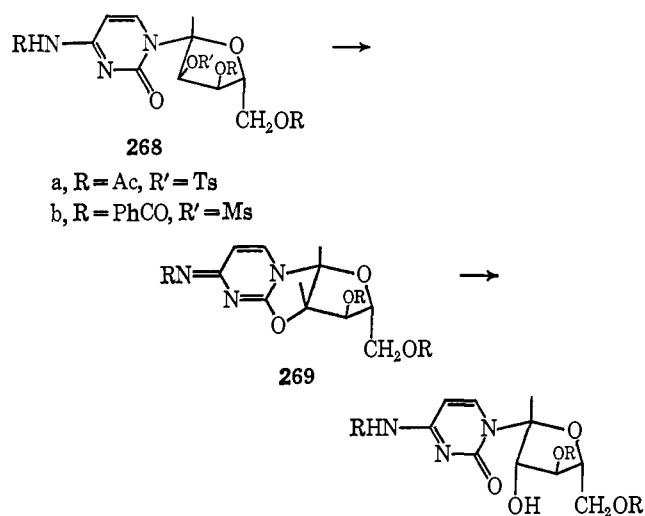

As with the thioamide group (see section XIV.G), participation by the 2-thiouracil ring occurs very readily and 5'-*O*-trityl-2'-*O*-methanesulfonyl-5-methyl-2-thiouridine spontaneously yields the 2,2'-anhydrothionucleoside (see eq 101a).^{712a}

Participation by a 2-amino group probably occurs in the reaction of 2,5'-anhydro-3'-*O*-methanesulfonylthymidine with

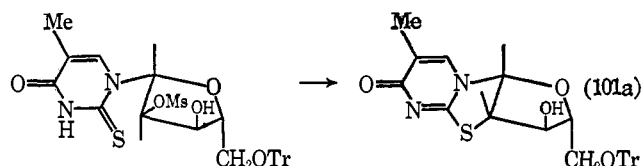

(711) H. P. M. Fromageot and C. B. Reese, *Tetrahedron Lett.*, 3499 (1966).

(712) (a) G. Shaw and R. N. Warriner, *J. Chem. Soc.*, 50 (1959); (b) I. L. Doerr, R. J. Cushley, and J. J. Fox, *J. Org. Chem.*, 33, 1592 (1968).

liquid ammonia to yield a 2,3'-imino compound (see eq 101b).^{712b}

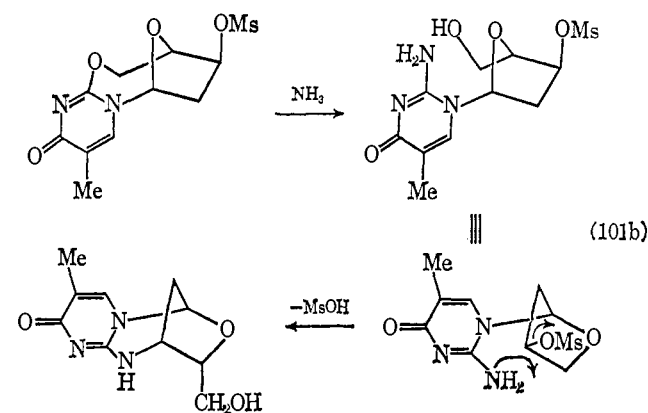

The β -D-xylofuranosylthymine **270** only forms an anhydronucleoside on refluxing with alcoholic sodium hydroxide solution.⁷¹³ In the absence of the fused dioxane ring, participation by the thymine residue normally requires much milder conditions than this. Presumably it is difficult to achieve a conformation with O(2) directly behind the methanesulfonyloxy group, owing to this requiring the dioxane to be distorted from a chair conformation.

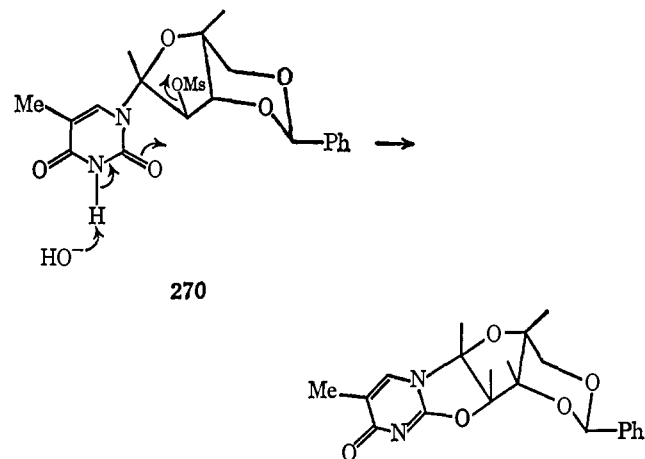

Although the question of competition between participation by the heterocyclic ring and the hydroxyl groups of the sugar does not arise with substitution at position 5' of ribonucleosides, with *xylo*, *arabino*, and *lyxo* nucleosides it does and is an important consideration.^{714,715} Thus when the arabinosyl- and xylosyluracil derivatives **271** and **272** are dissolved in sodium hydroxide, O-(4) and O-(5) participation occur in preference to participation by the ionized uracil ring, and with the lyxosyluracil **273**, for which O-(5), O-(4), and uracil participation are all possible, the first of these is what actually takes place. However, when the same arabinosyl- and xylosyluracil derivatives are treated with boiling water maintained at pH 5, participation by the uracil ring appears to compete quite successfully since the products include the 2,2'-anhydro-

(713) J. J. Fox, J. F. Codington, N. C. Yung, L. Kaplan, and J. O. Lampen *J. Amer. Chem. Soc.*, 80, 5155 (1958).

(714) I. L. Doerr, J. F. Codington, and J. J. Fox, *J. Org. Chem.*, 30, 467 (1965).

(715) J. F. Codington, I. L. Doerr, and J. J. Fox, *ibid.*, 30, 476 (1965).

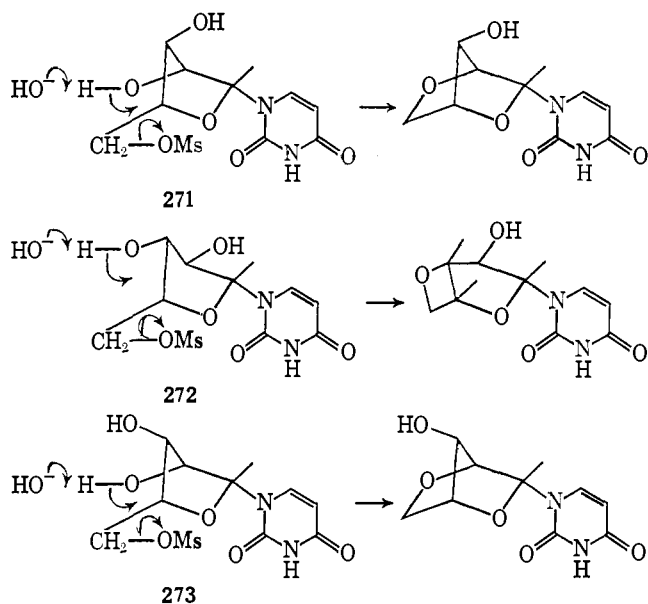

arabino- and 2,3'-anhydrouracils (**275** and **278**), probably formed *via* the corresponding 2,5'-anhydro compounds **274** and **277**. The 2',5'-anhydroarabino and 3',5'-anhydroxylo

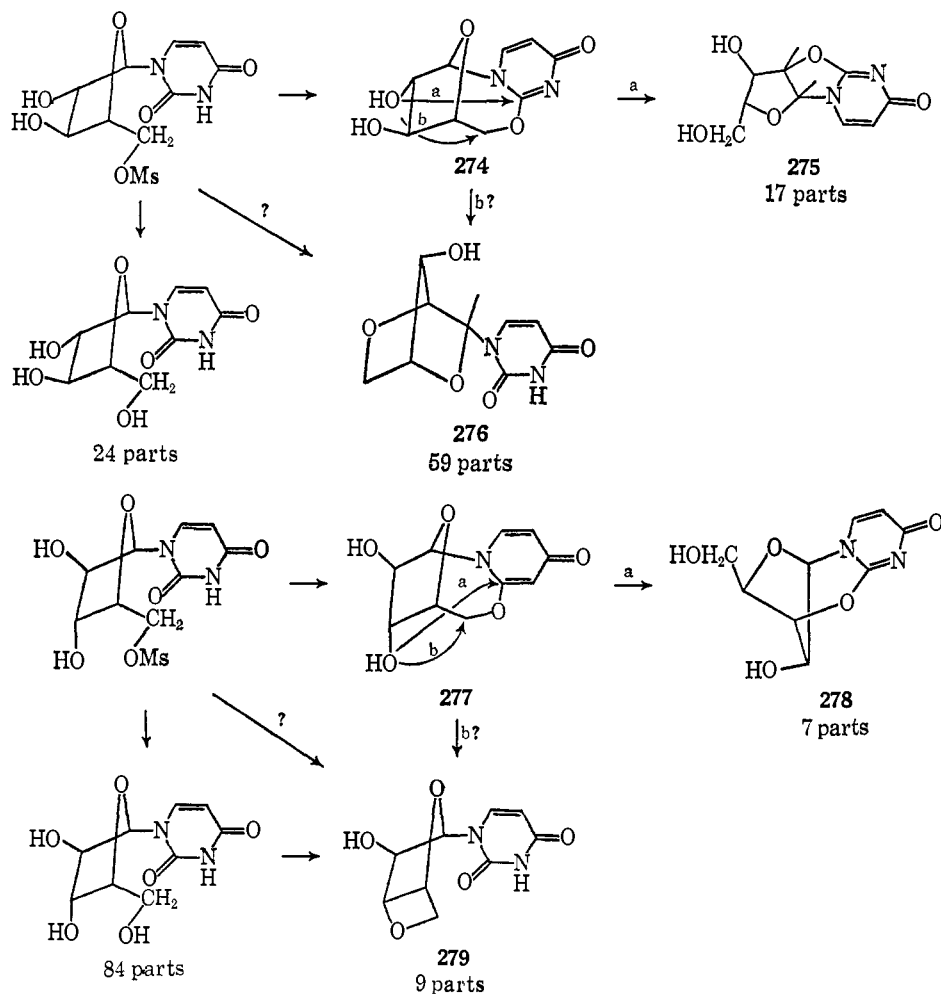

compounds **276** and **279**, which are also formed, could arise *via* the 2,5'-anhydro compounds or by direct displacement of the methanesulfonyloxy groups by the hydroxyls. The over-all rate for the arabinosyl compound is about five times greater than for the xylosyl one.^{714,715}

Participation by the heterocyclic base also competes successfully with HO(5), HO(4), and HO(3) participation in substitution at position 2' and 3' in neutral or slightly alkaline solution as illustrated by the reactions shown in eq 98–100 and 102,^{716a} 103,^{716b} and 104.⁷¹⁵ The pK_a 's of the uracil and thymine rings of nucleosides are 9–10, so in neutral solution the competition is between un-ionized forms of the heterocyclic rings and the hydroxyl groups, and in ammoniacal solution, probably between un-ionized hydroxyls and the ionized uracil and thymine rings.

Under strongly alkaline conditions the heterocyclic ring sometimes even competes successfully with the ionized hydroxyl group. Thus compound **280** reacts with participation by the cytosine ring rather than by O⁻(4) participation on treatment with sodium *t*-butoxide in dimethylformamide at 100°.⁷¹⁷ O⁻(4) participation in this stereochemical environment is known to be not very efficient, however (see ref 610). In contrast, O⁻(3) participation competes successfully with participation by the ionized uracil group (and with O⁻(5) at position 5') when 3,5-di-*O*-methanesulfonylarabinofuranosyluracil is treated with sodium hydroxide (see eq 105; *cf.* eq 98).⁷¹⁸

Treatment of 2-*O*-methanesulfonyl-β-D-xylofuranosyluracil (**281**) with 1 equiv of sodium hydroxide yields the 2,2'-anhydro

(716) (a) N. C. Yung, J. H. Burchenal, R. Fecher, R. Duschinsky, and J. J. Fox, *J. Amer. Chem. Soc.*, **83**, 4060 (1961); (b) J. J. Fox and N. C. Miller, *J. Org. Chem.*, **28**, 936 (1963).

(717) Y. Mizuno and T. Sasaki, *Tetrahedron Lett.*, 4579 (1965).

(718) J. F. Codington, R. Fecher, and J. J. Fox, *J. Org. Chem.*, **27**, 163 (1962).

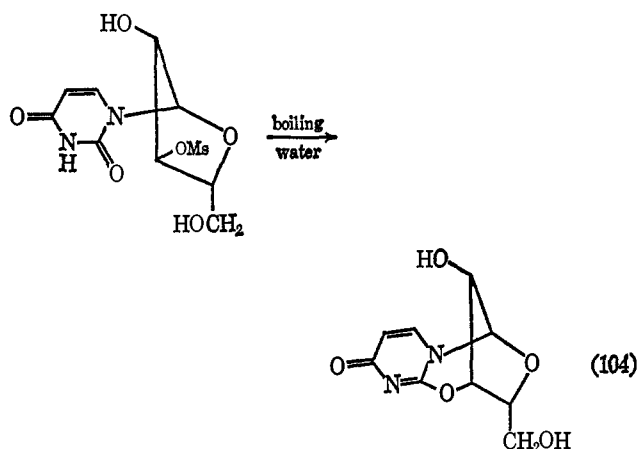
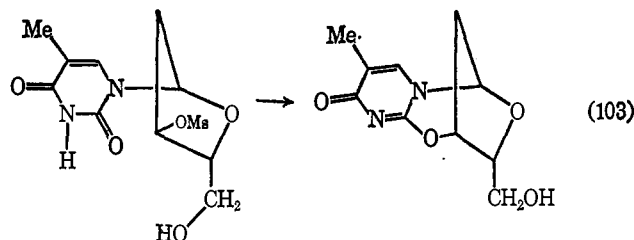
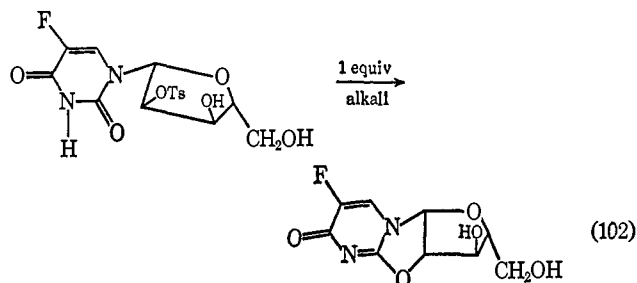

compound plus another compound thought to be the 2',3'-epoxide.⁷⁰⁷ Since the 1 equiv of sodium hydroxide must be used mainly in forming the salt of the uracil residue, this result suggests that O⁻(3) participation can compete successfully with participation by the ionized uracil group for substitution at position 2' as well as position 3'.

Participation by an ionized uracil residue attached to a pyranose ring competes successfully with amido-group par-

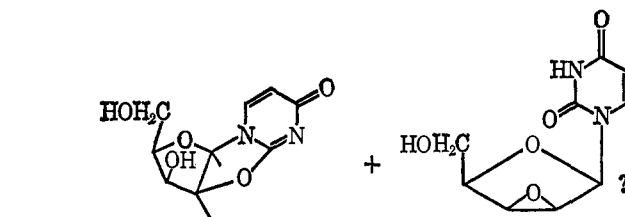
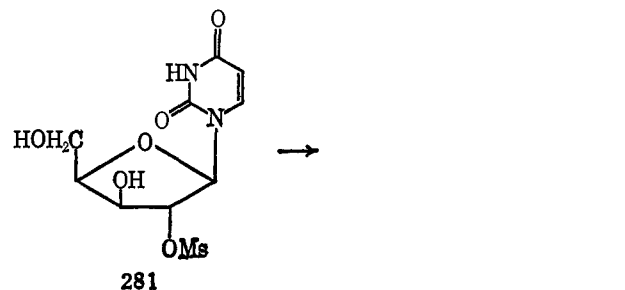
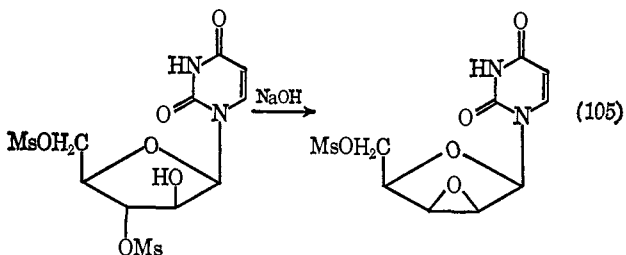
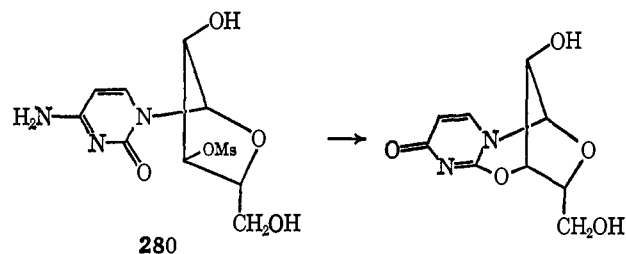

icipation when compound **282** is treated with sodium ethoxide in a mixture of ethanol and pyridine.⁷¹⁹

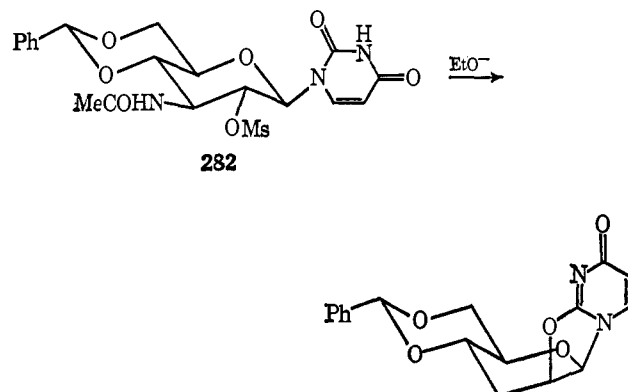

Several halide⁷²⁰ (see also ref 704, 716b, 721, 722) and benzoate^{716b} displacements (*e.g.*, eq 106–108) on the sugar rings of nucleosides which proceed very easily and with retention of configuration are thought to involve participation by the pyrimidine ring.

It was found in an independent experiment that the anhydro derivative **284** gave a good yield of **285** on treatment with sodium benzoate in dimethylformamide only if benzoic acid was also present. The latter should be formed in the cyclization step ($\text{MsOH} + \text{NaOCOPh} \rightarrow \text{MsONa} + \text{HOCOPh}$) and hence is present when **285** is formed from **283**. The ring opening of **284** must therefore be written as shown in **286**.^{716b}

Displacement reactions at position 3' of 2,2'-anhydrouridine derivatives also proceed with retention of configuration sometimes. Participation by the 2'-oxygen as shown in eq 109 has been invoked to explain this.^{716b,722} It was considered that intermediate **287** would be attacked preferentially at position 3' by analogy with epoxide-ring opening.

Neighboring group participation by the purine ring of derivatives of purine nucleosides also occurs and indeed the first anhydronucleoside to be prepared was a derivative of

(719) K. Watanabe and J. J. Fox, *J. Org. Chem.*, **31**, 211 (1966).

(720) T. Naito, M. Hirata, Y. Nakai, T. Kobayashi, and M. Kanao, *Chem. Pharm. Bull.* (Tokyo), **13**, 1258 (1965); **16**, 285 (1968).

(721) D. M. Brown, D. B. Parfhar, C. B. Reese, and A. R. Todd, *J. Chem. Soc.*, 3035 (1958).

(722) K. E. Pfitzner and J. G. Moffatt, *J. Org. Chem.*, **29**, 1508 (1964); M. Hirata, *Chem. Pharm. Bull.* (Tokyo), **16**, 291 (1968).

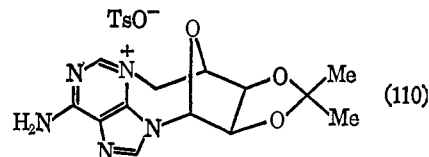
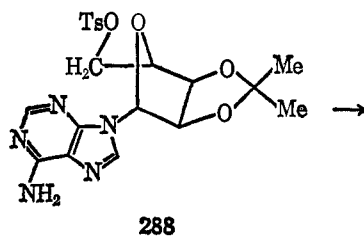
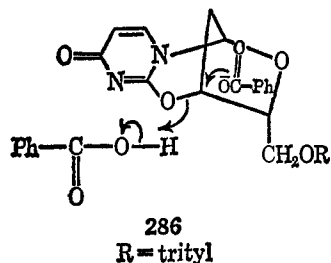
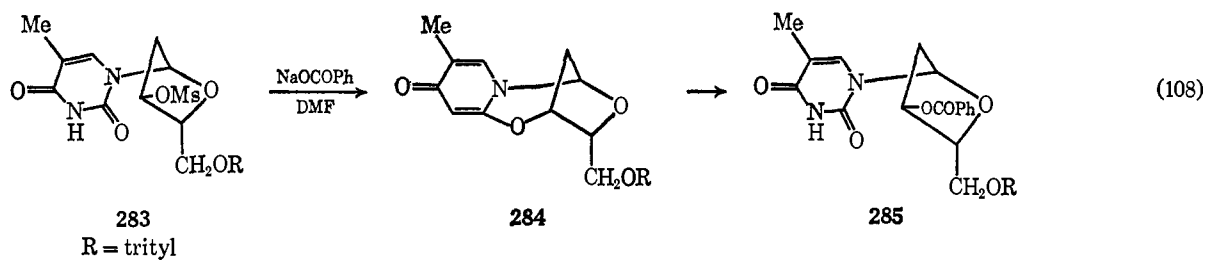
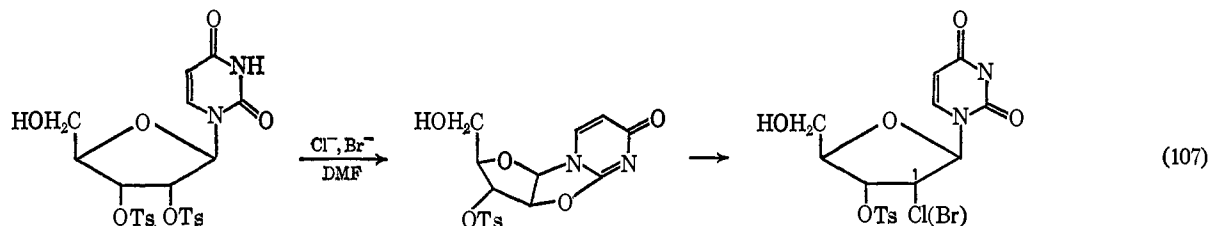
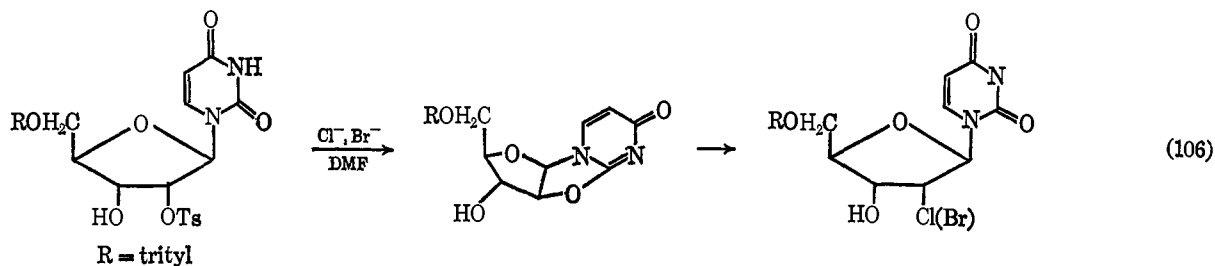

analogous guanosine (291,⁷²⁶ see also ref 727, 728), xanthosine (292),⁷²⁶ and inosine (293) derivatives, although the last of these does not react in acetone under conditions where the

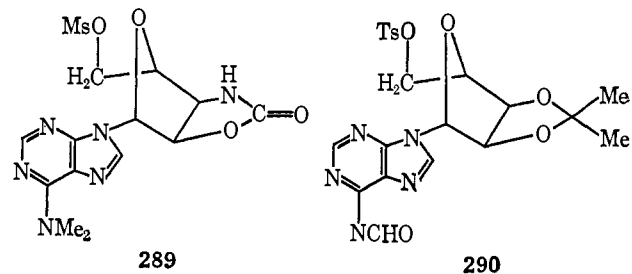
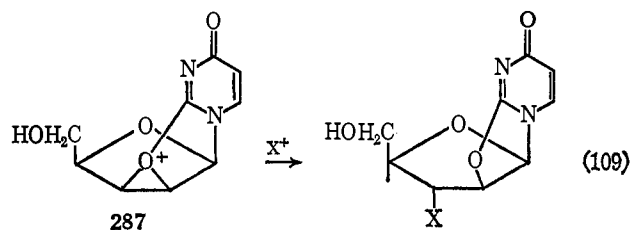
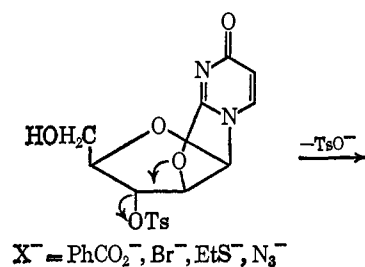

adenosine derivative 288 reacts easily. This is presumably the result of the lower basicity (and nucleophilicity) of the purine ring of inosine ($pK_a = 1.2$) compared to that of adenosine ($pK_a = 3.45$).⁷⁰²

3,5'-anhydroadenosine (see eq 110;⁷⁰² see also ref 723). When the amino group is methylated as in compound 289, participation still occurs readily,⁷²⁴ but when it is acylated as in 290, participation is inhibited.⁷²⁵ Participation also occurs with the

(723) E. J. Reist, D. F. Calkins, and L. Goodman, *J. Org. Chem.*, **32**, 169 (1967).

(724) B. R. Baker and J. P. Joseph, *J. Amer. Chem. Soc.*, **77**, 15 (1955).

(725) W. Jahn, *Chem. Ber.*, **98**, 1705 (1965).

(726) R. E. Holmes and R. K. Robins, *J. Org. Chem.*, **28**, 3483 (1963).

(727) R. W. Chambers, J. G. Moffatt, and H. G. Khorana, *J. Amer. Chem. Soc.*, **79**, 3747 (1957).

(728) (a) E. J. Reist, P. A. Hart, L. Goodman, and B. R. Baker, *J. Org. Chem.*, **26**, 1557 (1961); (b) M. Ikehara and K. Muneyama, *ibid.*, **32**, 3039 (1967).

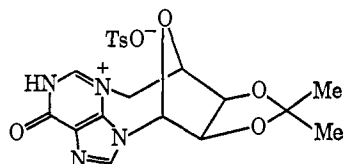
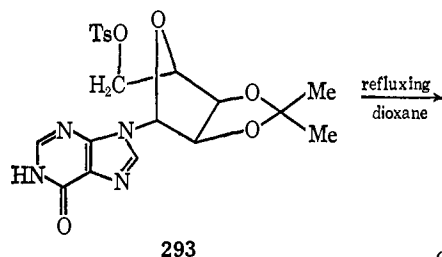
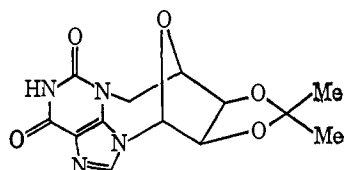
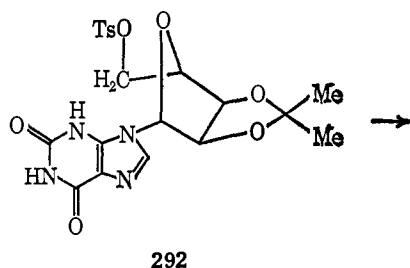
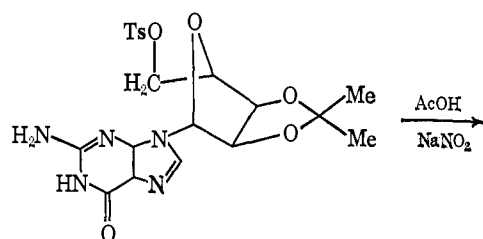
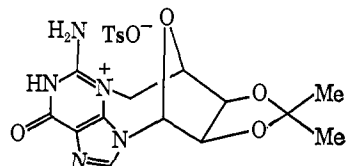
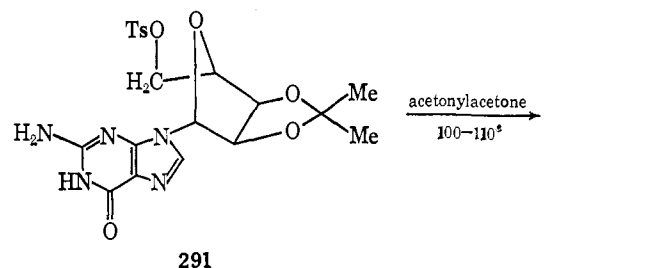

Participation by the adenine ring in reactions at positions 2' and 3' has been much less investigated. Treatment of the β -D-xylofuranosyl derivative **294** with sodium methoxide results in O-(3) participation rather than participation by the adenine,⁷²⁹ and compound **295** reacts with participation by the

(729) W. W. Lee, A. Benitez, L. Goodman, and B. R. Baker, *J. Amer. Chem. Soc.*, **82**, 2648 (1960); E. J. Reist, L. V. Fisher, and L. Goodman, *J. Org. Chem.*, **33**, 189 (1968).

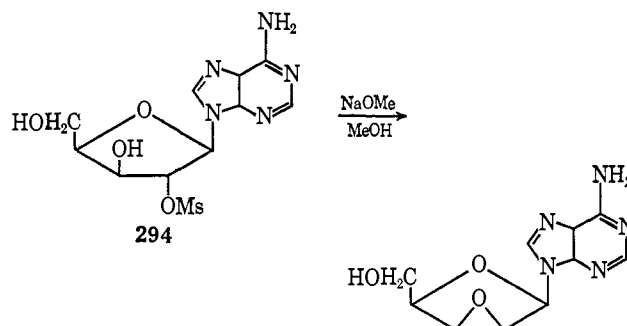

amido group rather than with participation by the *N,N*-dimethyladenine ring.^{730a} Participation by a thioether group has also been reported to occur in preference to participation by the adenine ring.^{730b}

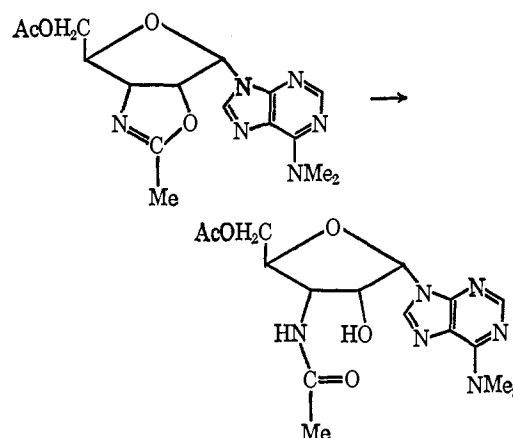
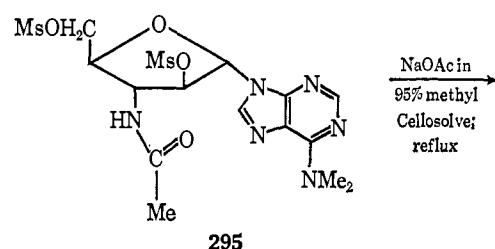

A small amount of the 3,3'-anhydronucleoside **298** has been obtained on treatment of **296** with sodium acetate in refluxing 2-methoxymethanol. It was suggested that participation by the benzylthio group occurred first followed by participation by the adenine ring.^{731a} It is of interest that if the structure of **298** is correctly assigned, attack by the adenine ring occurs at position 3' rather than at 2'. Similar participation has been suggested to occur with an epoxide of structure analogous to that of episulfonium ion **297**.^{731b,732}

Several examples are known of attack at positions 2' and 3' by the mercapto group of 8-mercaptoadenosine and -guanosine derivatives (eq 111–114).^{733,734} Attack at position 2' is

(730) (a) B. R. Baker and R. E. Schaub, *J. Amer. Chem. Soc.*, **77**, 2396 (1955); (b) C. D. Anderson, L. Goodman, and B. R. Baker, *ibid.*, **81**, 3967 (1959).

(731) (a) A. Martinez, W. W. Lee, and L. Goodman, *J. Org. Chem.*, **31**, 3263 (1966); (b) E. J. Reist, D. F. Calkins, and L. Goodman, *ibid.*, **32**, 2538 (1967).

(732) E. J. Reist, V. J. Bartuska, D. F. Calkins, and L. Goodman, *ibid.*, **30**, 3401 (1965).

(733) M. Ikehara and H. Tada, *J. Amer. Chem. Soc.*, **87**, 606 (1965).

(734) (a) M. Ikehara and H. Tada, *Chem. Pharm. Bull. (Tokyo)*, **15**, 94 (1967); (b) M. Ikehara and K. Muneyama, *J. Org. Chem.*, **32**, 3042 (1967); for a recent review see M. Ikehara, *Accounts Chem. Res.*, **2**, 47 (1969).

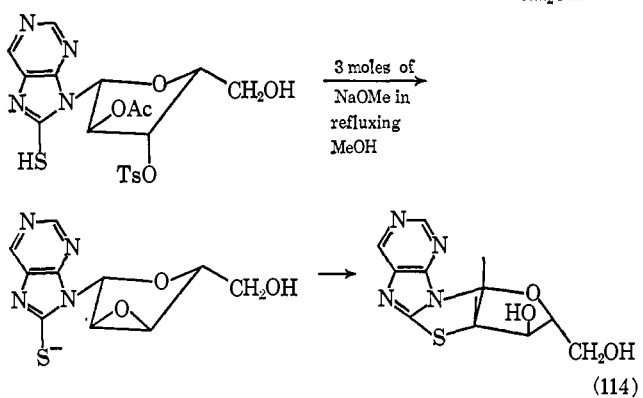
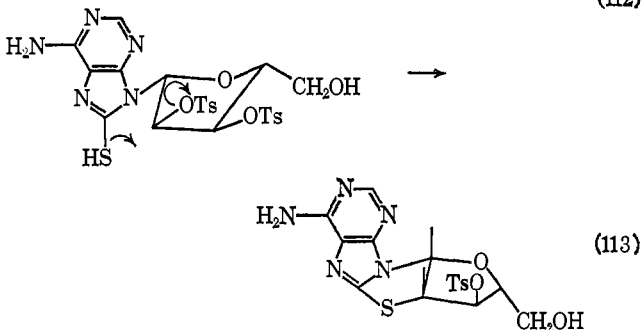
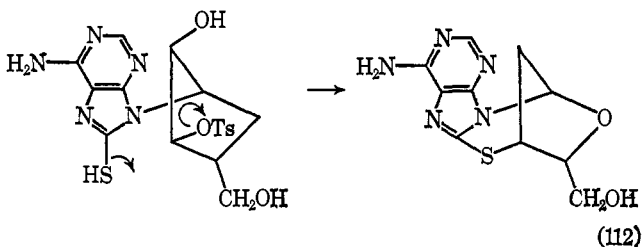
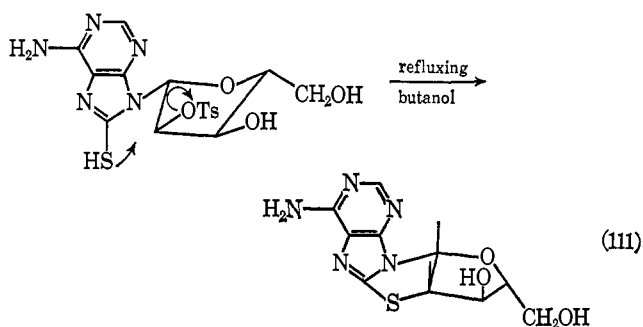
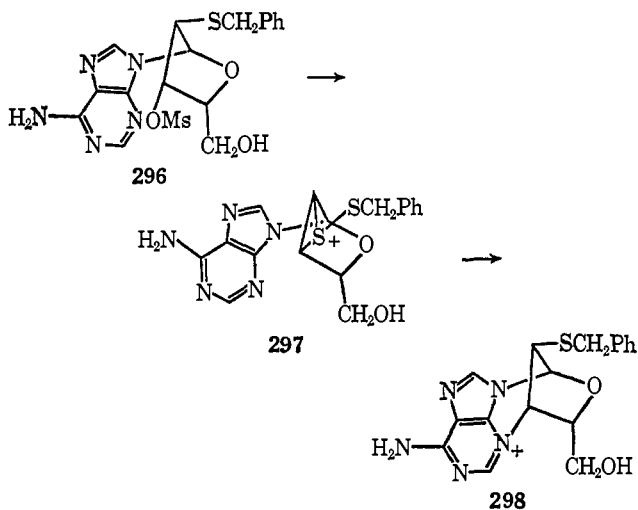

avored. Analogous participation by an 8-hydroxyadenine^{735a} and an 8-oxoguanine^{728b} ring is also known. An 8,5'-*O*-anhydroadenosine has been prepared by an intramolecular displacement by the 5'-hydroxyl group at position 8 of 2',3'-*O*-isopropylidene-8-bromoadenosine in dry dioxane in the presence of sodium hydride.^{735b}

Participation by the adenine ring occurs in the addition of bromine to 6-amino-9-(5-deoxy- β -D-erythro-pent-4-enofuranosyl)purine with formation of a 3,4-cyclonucleoside.^{735c} The formation of a branched chain cyclonucleoside is described in ref 577b and of an α -cyclonucleoside in ref 735d.

XV. Oxidation of Aldoses with Bromine⁷³⁶⁻⁷³⁸

Although much of our basic knowledge of these reactions was obtained by Isbell and his coworkers in their admirable, pioneering studies of the 1930's,^{427,464,739-744} it is still not possible to write a detailed mechanism with any certainty. The primary products of the oxidation of an aldose could be the aldonic acid or its γ - or δ -lactone. Since these are interconverted fairly readily in aqueous solution, some care has to be taken in finding which is formed first. In acidic solutions of D-gluconic acid ($pK_a = 3.81$) and its lactones, the equilibrium mixture contains 73% free acid, 11% γ -lactone, and 16% δ -lactone,⁷⁴⁵ but at pH's above 2.0-2.5 the proportion of lactones is reduced because of the formation of gluconate ions which displaces the equilibrium away from lactones. A similar picture probably holds for the other aldonic acids as well. In the pH range 3-7 then, where the bromine oxidation of aldoses has been most studied, the glucono- and probably the other aldolactones are unstable thermodynamically, and if they are formed they must result from the direct oxidation of the aldose rather than from lactonization of the acid. δ -Lactones have thus been shown to be the predominant kinetically controlled product of the oxidation of both forms of glucose and some other aldoses. The evidence for this is of two kinds. Hudson and Isbell⁷⁴⁰ studied the change in optical rotation which occurred in the oxidation of a mutarotated solution of glucose in an acetate buffer of initial pH about 5.7. The value of $[\alpha]_D$, based on glucose, rose from +52.4 to +66.4° after 4 min, at the end of which time titration of the unreacted bromine showed that there had been 52.7% oxidation. The rotation (after removal of bromine) then fell slowly at approximately the same rate as that observed in the hydrolysis of glucono- δ -lactone to a value of +10.5° after 4320 min and then rose again slowly to +13.3°. This can be ascribed to hydrolysis of the δ -lactone followed by relactonization to γ -lactone. Assuming that the value of $[\alpha]_D$ of the glucose remained steady at 52.4°, Hudson and Isbell calculated that

(735) (a) M. Ikehara, H. Tada, K. Muneyama, and M. Kaneko, *J. Amer. Chem. Soc.*, **88**, 3165 (1966); M. Ikehara and M. Kaneko, *Chem. Pharm. Bull. (Tokyo)*, **15**, 1261 (1967); M. Ikehara, H. Tada, and M. Kaneko, *Tetrahedron*, **24**, 3489 (1968); (b) M. Ikehara and M. Kaneko, *J. Amer. Chem. Soc.*, **90**, 497 (1968); J. R. McCarthy, R. K. Robins, and M. J. Robins, *ibid.*, **90**, 4933 (1968); (c) M. Ikehara, M. Kaneko, and Y. Nakahara, *Tetrahedron Lett.*, 4707 (1968).

(736) J. W. Green, *Advan. Carbohydr. Chem.*, **3**, 129 (1948).

(737) F. Shafizadeh, *ibid.*, **13**, 9 (1958).

(738) I. R. L. Barker, *Chem. Ind. (London)*, 1936 (1964).

(739) H. S. Isbell, *J. Amer. Chem. Soc.*, **54**, 1692 (1932).

(740) H. S. Isbell and C. S. Hudson, *J. Res. Nat. Bur. Stand.*, **8**, 327 (1932).

(741) H. S. Isbell, *ibid.*, **8**, 615 (1932).

(742) H. S. Isbell, *J. Amer. Chem. Soc.*, **55**, 2166 (1933).

(743) H. S. Isbell and W. W. Pigman, *J. Res. Nat. Bur. Stand.*, **10**, 337 (1933).

(744) H. S. Isbell and W. W. Pigman, *J. Org. Chem.*, **1**, 505 (1937).

(745) J. S. Woodman, Ph.D. Thesis, University of London, 1964, p 54.

after 4 min the rotation of the lactone was $+73.3^\circ$. This is somewhat higher than the reported rotation of $+66.2^\circ$, but this discrepancy is undoubtedly due to β -glucose being oxidized more rapidly than α -glucose (see below) and their interconversion not being fast under Hudson and Isbell's conditions. The net rotation of the glucose thus changes to a more positive value.

Similar changes in rotation were observed for mutarotated solutions of D-galactose, L-arabinose, D-xylose, and lactose (see Table LXVI) and were interpreted similarly, although some

Table LXVI

Change in Specific Rotation on Oxidation of Mutarotated Aldoses with Bromine

Aldose	Initial $[\alpha]_D$, deg	Max or min $[\alpha]_D$, deg
D-Glucose	+52.4	+66.4
D-Galactose	+80	+120
L-Arabinose	+105	+120
D-Xylose	+20	-28
Lactose	+53	+60

uncertainty is introduced by the corresponding δ -lactones all being unknown. It is of interest that the results indicate that D-xylo- δ -lactone has a negative rotation. Shortly after this work was published, Isbell^{741,742} and Isbell and Pigman⁷⁴³ reported the results of an investigation using a heterogeneous barium carbonate-carbon dioxide buffer. This time anomerically pure aldoses were used, and after removal of the buffer the amount of product that had not been neutralized by it was determined by titration with barium hydroxide. Any aldonic acid that was formed should have been neutralized by the buffer, but a lactone would not have been. The results obtained are shown in Table LXVII. The low values obtained with some

Table LXVII

Oxidation of Aldoses by Bromine Water in the Presence of Barium Carbonate

Aldose	Oxidation product present as lactone, %	Aldose	Oxidation product present as lactone, %
α -D-Glucose	87.4	β -L-Rhamnose	97.5
β -D-Glucose	95.8	α -Lactose	76.0
α -D-Mannose	99.0	β -Lactose	89.4
β -D-Mannose	98.6	β -Cellobiose	74.6
α -L-Rhamnose	98.5	β -Maltose	96.3

of the disaccharides were attributed to the greater rates of hydrolysis of the δ -lactones. This work also showed that β -aldoses are generally oxidized considerably faster than α -aldoses. Attempts to isolate δ -lactones from these reactions were not very successful owing undoubtedly to the high rate of hydrolysis. Thus Isbell and Pigman⁷⁴³ isolated only 5 g of crude δ -lactone from 9 g of β -D-glucose.

The most striking kinetic result is that aldoses with the hydroxyl group at C(1) equatorial (*i.e.*, usually β) are oxidized much more rapidly than their axial anomers, and because of this the most thoroughly investigated oxidation is that of

β -D-glucose. Barker, Overend, and Rees^{746,747} reported that unlike the oxidation of secondary alcohols (*cf.* ref 748), which is a second-order reaction, the oxidation of β -D-glucose (0.5 – $5.0 \times 10^{-2} M$) with bromine (0.55 – $5.1 \times 10^{-2} M$) shows complex kinetics. At pH 5 in an acetate buffer the order is less than one with respect to bromine as determined from the initial rate but greater than one with respect to β -D-glucose. Such a result could possibly arise from complex formation between the glucose and bromine, but there is no independent evidence for this. When the reaction was studied with a tenfold excess of bromine ($5 \times 10^{-2} M$), the first-order rate constants calculated from the integrated rate expression decreased by 50% over 80% reaction which is much more markedly than would be expected when allowance is made for the bromine consumed by the oxidation and by conversion to tribromide ion. This behavior is of course that to be expected if β -glucose were converted to α -glucose concurrently with the oxidation, but since the rate of mutarotation in the same buffer in the absence of bromine is less than $1/60$ th the rate of oxidation, a bromine-catalyzed anomerization of β -glucose was postulated, but its occurrence was not confirmed by showing the presence of α -glucose in the reaction mixture.

In contrast to these results Perlmutter-Hayman and Persky⁷⁴⁹ working with mutarotated glucose and bromine in deficit reported good second-order behavior when allowance was made for the conversion of bromine to tribromide ion, and Isbell and Pigman also reported second-order kinetics.⁷⁴⁸

Both Barker, Overend, and Rees^{746,747} and Perlmutter-Hayman and Persky⁷⁴⁹ found that oxidation by hypobromous acid is very slow and that tribromide ion is inactive, and concluded that the active oxidizing species is bromine. There is also general agreement that the rate of reaction increases with increasing pH above about pH 2. This was first demonstrated by Bunzel and Matthews⁷⁵⁰ and Perlmutter-Hayman and Persky obtained the pH-rate profile shown in Figure 7. In the pH range 3–7 the rate is approximately proportional to the concentration of ^-OH but below pH 1 is independent of pH.

It has not been shown conclusively whether the reaction shows specific or general base catalysis. It has been reported⁷⁴⁹ that at pH 2.47 the rate was the same in the presence of 0.37 *M* sodium nitrate as in the presence of 0.3 *M* sodium dihydrogen phosphate and 0.1 *M* phosphoric acid, and it was concluded that there is "no specific influence of the buffer ion." However, since pH 2.47 is outside the pH range in which the rate is proportional to the concentration of ^-OH , a more thorough investigation with several different bases in the pH range 3–7 is clearly desirable before a definite conclusion can be reached.

The dependence of the rate on the concentration of ^-OH was explained⁷⁴⁹ as resulting from the anion of glucose being much more reactive than the un-ionized form which would require specific HO^- catalysis. This would mean that the rate constant for the reaction of the anion with bromine is approximately 10^8 – 10^7 l. mole⁻¹ sec⁻¹, while that for the un-ionized species is 10^{10} – 10^{11} -fold less. Although at first sight this difference appears to be very large,⁷⁴⁷ it would not in fact be un-

(746) I. R. L. Barker, W. G. Overend, and C. W. Rees, *Chem. Ind.* (London), 1297 (1960).

(747) I. R. L. Barker, W. G. Overend, and C. W. Rees, *J. Chem. Soc.*, 3254 (1964).

(748) N. C. Deno and N. H. Potter, *J. Amer. Chem. Soc.*, 89, 3555 (1967); N. Venkatasubramanian and V. Thiagarajan, *Tetrahedron Lett.*, 1711 (1968).

(749) B. Perlmutter-Hayman and A. Persky, *J. Amer. Chem. Soc.*, 82, 276 (1960).

(750) H. H. Bunzel and A. P. Matthews, *ibid.*, 31, 464 (1909).

reasonable if the rate were controlled partly by the formation of a species **299**. This is because **299** is analogous to the species,

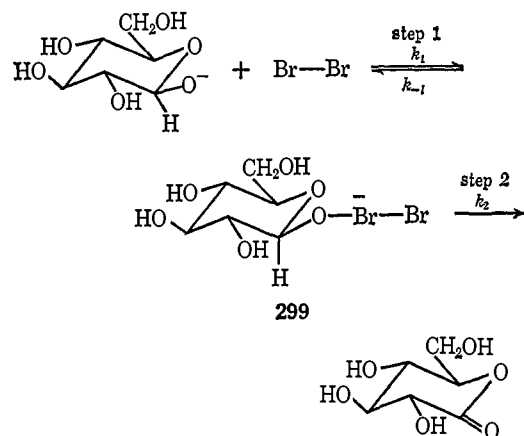

Br_2OH^- , demonstrated by Eigen and Kustin⁷⁵¹ to intervene in the hydrolysis of bromine and whose formation from Br_2 and OH^- is diffusion controlled with a rate constant 10^{10} l. mole⁻¹ sec⁻¹, but whose formation from Br_2 and H_2O has a second-order rate constant of only 2.0 l. mole⁻¹ sec⁻¹. This hypothesis also provides a simple explanation of the high equatorial axial rate ratio since it has been shown⁴⁸⁶ by nmr spectroscopy that in alkaline, unlike in neutral, solution glucose exists almost wholly in the β (equatorial) form. β -Glucose is therefore a much stronger acid than α -glucose and the high β : α (eq:ax) rate ratio could result from there being a higher concentration of its anion present under the conditions of the oxidation.

The rate of oxidation cannot be controlled completely by the rate of formation of **299** though, since a primary isotope effect has been observed in the oxidation of $[1\text{-}^3\text{H}]\text{glucose}$.^{752,753} Further, if the rate of step 1 were similar to that for attack by OH^- on bromine, at pH 5 the second-order rate constant based on total glucose would be about 100 l. mole⁻¹ sec⁻¹ which is much greater than the observed rate constant for the oxidation, viz., 10^{-2} l. mole⁻¹ sec⁻¹. The decomposition of **299** must therefore be partly rate determining, and if this were so the measured rate constant defined by the equation, rate = $k[\beta\text{-glucose}][\text{Br}_2]/[\text{H}^+]$, would be $K_a k_1 k_2 / (k_{-1} + k_2)$ with $k_2 / (k_{-1} + k_2)$ equal to 10^{-4} and K_a , the acid dissociation constant of β -glucose, equal to about 10^{-12} mole l.⁻¹.

Various other mechanisms have been proposed from time to time^{747,754-756} but in the reviewer's opinion the one given above is the most satisfactory. Its main weakness is that in common with the others it does not explain the complex kinetic results reported by Barker, Overend, and Rees.⁷⁴⁷ Intervention of a glucosyl hypobromite as well as species **299** would lead to a more complex rate expression, but until the importance of the bromine-catalyzed anomerization has been evaluated more thoroughly, and the presence or absence of a complex between bromine and glucose has been established, this point must remain open.

(751) M. Eigen and K. Kustin, *J. Amer. Chem. Soc.*, **84**, 1355 (1962).

(752) F. Friedberg and L. Kaplan, Abstracts, 131st National Meeting of the American Chemical Society, Miami, Fla., 1957, 86-O.

(753) H. S. Isbell and L. T. Sniegoski, *J. Res. Nat. Bur. Stand.*, **A68**, 145 (1964).

(754) R. Bentley, *J. Amer. Chem. Soc.*, **79**, 1720 (1957).

(755) H. S. Isbell, *J. Res. Nat. Bur. Stand.*, **A66**, 233 (1962).

(756) R. Bentley, *J. Amer. Chem. Soc.*, **81**, 1952 (1959).

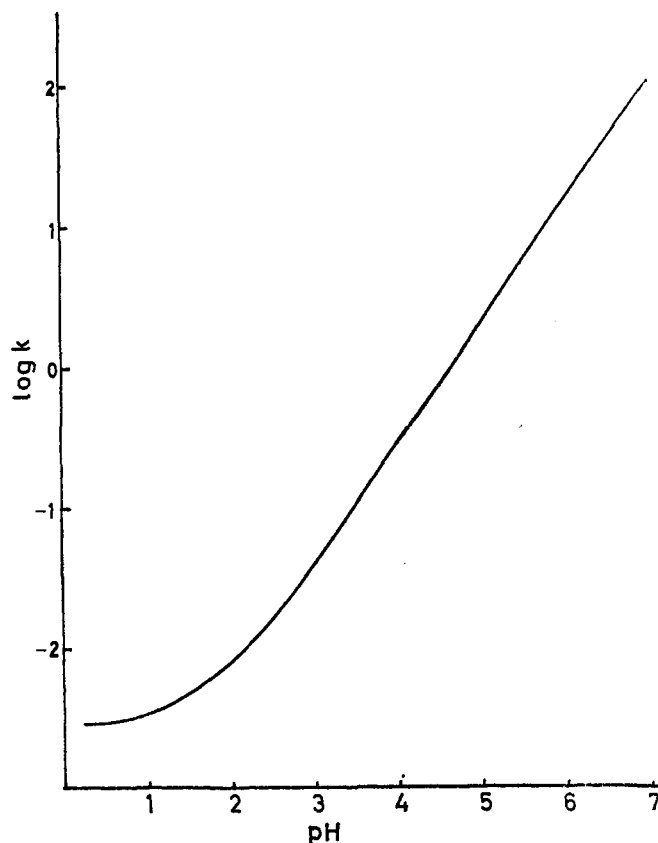

Figure 7. The dependence on pH of log k for the oxidation of D-glucose by bromine.

Below pH 1 the rate of oxidation of mutarotated glucose is independent of the pH, and under these conditions it is possibly the neutral molecule which is reacting.⁷⁴⁹ At pH 0 the rate is proportional to the total concentration of bromine, $\text{Br}_2 + \text{Br}_3^-$.⁷⁴⁷ This behavior is similar to that observed for the oxidation of acetaldehyde and it led Barker, Overend, and Rees to suggest that it is the acyclic aldehydrol form of glucose which is being oxidized.⁷⁴⁷

The effect of the structure of the aldose on the rate of oxidation was studied extensively by Isbell and Pigman.⁴²⁷ The rate constants for a number of aldoses (mainly β) in which the hydroxyl group is equatorial are given in Table LXVIII. The over-all variation in the rates is not very large which suggests that there is little conformational movement on forming the

Table LXVIII

Second-Order Rate Constants for the Oxidation of Aldoses (0.05 M) by Bromine (0.08 M) in a Barium Carbonate-Carbon Dioxide Buffer at +0.3^{o427}

Aldose	$10^2 k$, l. mole ⁻¹ sec ⁻¹ ^a	Aldose	$10^2 k$, l. mole ⁻¹ sec ⁻¹ ^a
β -D-Glucose	4.82	β -D-Xylose	6.42
β -D-Mannose	3.00	β -D-Lyxose	1.91
β -D-Galactose	6.10	β -D-Ribose	3.88
β -D-Talose	3.24	β -L-Rhamnose	2.96
β -D-Gulose	1.60	β -Lactose	3.65
β -D-Arabinose	6.36	β -Maltose	5.86

^a See footnote to Table IX.

transition state consistent with the mechanism suggested above.

The rates of oxidation of some α -aldoses were also measured but since these reactions are much slower (see also ref 754, 756) there is the possibility that oxidation *via* the β anomers might be an important pathway. This was clearly recognized by Isbell and Pigman,⁴²⁷ but unfortunately they could not measure the rate of mutarotation under the same conditions as they measured the rate of oxidation, *i.e.*, in heterogeneous buffers, and hence it is difficult to decide from their results what proportion of the oxidations were direct oxidation of the α -aldoses. Barker, Overend, and Rees studied the oxidation and the mutarotation of α -D-glucose under the same conditions (Table LXIX).^{746,747} It is seen that at pH 5-6 the oxida-

Table LXIX

Comparison of the Rates of Mutarotation and Oxidation of α -D-Glucose^{746,747}

pH	Buffer	Mutarotation		Oxidation $10^4 k_1$, sec^{-1}^a
		$10^4(k_1 + k_{-1})$, sec^{-1}	$10^4 k_1$, sec^{-1}	
4	Acetate	5.80	3.79	2.54
5	Acetate	4.95	3.23	4.11
6	Acetate	4.95	3.23	6.91
6	Phosphate	24.6	16.0	16.4

^a $[\text{Br}_2] = 0.10 M$, $[\alpha\text{-glucose}] = 0.005 M$.

tion is only slightly faster than the conversion of α - to β -glucose, and at pH 4 it is slower. The proportion of direct oxidation will of course depend on the concentration of bromine. In these experiments the concentration of bromine (0.10 M) appears to be similar to that used by Isbell and Pigman,⁴²⁷ although there is some uncertainty as the latter workers used a high concentration of barium bromide and calculated the concentration of free bromine to be 0.08 M using the equilibrium constant for the formation of the tribromide ion determined for potassium bromide solution. From the results in Table LXIX it would therefore appear that the major pathway for oxidation is *via* β -glucose. This conclusion is supported by the observation that the rate of oxidation of α -D-glucose is very much less than first order in bromine.^{746,747} On the assumption that the reaction which was dependent on the concentration of bromine was direct oxidation of α -D-glucose, Barker, Overend, and Rees calculated that this was 250 times slower than that of β -D-glucose. They also showed^{747,757} that there was a linear logarithmic correlation between the rates of oxidation of all the α -aldoses studied by Isbell and Pigman,⁴²⁷ except α -lyxose, and their rates of mutarotation, and concluded that most of these underwent oxidation *via* their β anomers also (see, however, ref 758).

This conclusion is also supported by the work of Isbell and Sniegoski.⁷⁵⁸ Again it is difficult to ascertain the exact concentration of bromine used since the authors report that 100 ml of the reaction solution contains 3 ml of bromine which corresponds to a concentration of approximately 0.6 M , larger

than the reported solubility of bromine.⁷⁵⁹ Their method involved working with aldoses tritiated at C(1) and measuring the over-all isotope effect. It was claimed that, if the α -aldose were oxidized directly, the reaction should show an isotope effect $k_T/k_H = 0.14$, while, if conversion to β -aldose were the rate-determining step, k_T/k_H should be about 0.8, and an intermediate value would be obtained if oxidation were occurring by both routes. In this way the proportions of direct oxidation given in Table LXX were calculated from the measured over-

Table LXX

Proportion of Direct Oxidation Occurring with Aldoses with an Axial Hydroxyl Group

Aldose	% direct oxidation	Aldose	% direct oxidation
α -D-Galactose	37.5	α -L-Arabinose	73.0
α -D-Glucose	41.2	α -D-Lyxose	93.9
α -D-Mannose	75.6	α -D-Ribose	81.8
α -D-Talose	90.9	α -D-Xylose	81.8
α -L-Rhamnose	83.3	Lactose	50.0

all isotope effects. It is difficult to decide how reliable they are since they are clearly sensitive to the values assumed for the isotope effects of the individual pathways. Since the experiments were carried out with a higher concentration of bromine than used originally by Isbell and Pigman,⁴²⁷ they are nevertheless in good agreement with Barker, Overend, and Rees's conclusions. The high rate of oxidation of α -D-lyxose is consistent with its existing appreciably in the alternative conformation with the hydroxyl group at C(1) equatorial as indicated by its nmr spectrum.^{105, 474}

XVI. Reactions of Aldonic Acids and Their Derivatives

There have been few kinetic or mechanistic investigations on reactions of this class of compounds apart from the classic studies of Haworth and Levene and their coworkers on the hydrolysis of aldonolactones (usually methylated) and the lactonization of aldonic acids.⁷⁶⁰⁻⁷⁶² The proportions of lactone at equilibrium and the half-lives for hydrolysis of the lactones as determined conductometrically for initially neutral aqueous solutions at 25° are given in Table LXXI. The results for the methylated lactones are simplest to interpret since they cannot relactonize to form another lactone. The δ -lactones are hydrolyzed more rapidly than the γ -lactones with the relative rates varying from about 80 for the tetra-*O*-methylgluconolactones to 5.5 for the tri-*O*-methylxyloolactones. This may be compared to the 100-fold greater rate of hydrolysis in acid solution of δ -valerolactone compared to γ -butyrolactone.⁷⁶³

The greater rate of hydrolysis of δ -lactones compared to γ -lactones is usually ascribed to relief of the unfavorable eclips-

(757) I. R. L. Barker, W. G. Overend, and C. W. Rees, *Chem. Ind.* (London), 1298 (1960).

(758) H. S. Isbell, *ibid.*, 593 (1961).

(759) A. Seidell and W. F. Linke, "Solubilities of Inorganic and Metal-Organic Compounds," Vol. 1, 4th ed, D. Van Nostrand Co., Inc., Princeton, N. J., 1958, p 440.

(760) H. D. K. Drew, E. H. Goodyear, and W. N. Haworth, *J. Chem. Soc.*, 1237 (1927).

(761) S. R. Carter, W. N. Haworth, and R. A. Robinson, *ibid.*, 2125 (1930).

(762) P. A. Levene and H. S. Simms, *J. Biol. Chem.*, 65, 33 (1925).

(763) O. H. Wheeler and E. E. G. de Rodriguez, *J. Org. Chem.*, 29, 1227 (1964).

ing interaction between the carbonyl group and the equatorial substituent at C(2) on going to the transition state (*cf.* ref 764). This appears to be consistent with the slower hydrolysis of tetra-*O*-methyl- δ -D-mannolactone (**300**) compared to the gluconolactone (**301**) since with the former the equatorial sub-

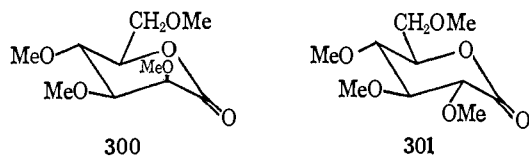

stituent at C(2) is hydrogen while with the latter it is methoxyl. The proportions of acid and lactone present at equilibrium in these reactions have been discussed by Lemieux.⁷⁶⁵

In neutral solution unmethylated D-glucono- γ -lactone is converted directly into the δ -lactone. This was first suggested by Jermyn on the basis that in the pH range 5.2–7.2 the hydrolysis of the γ -lactone does not follow the first-order rate law

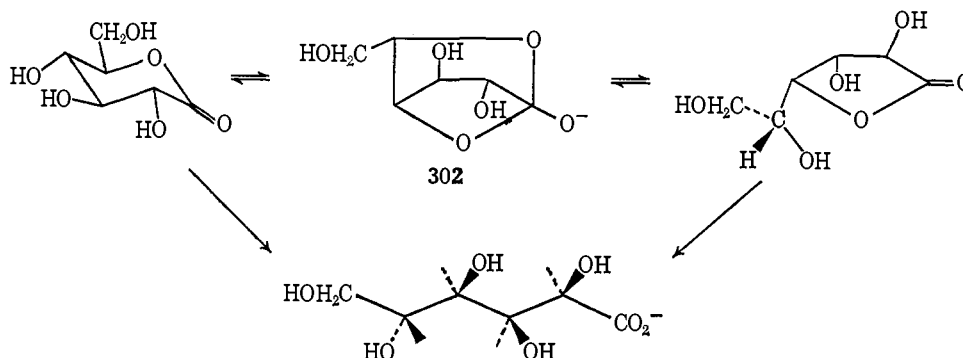

but shows an induction period.⁷⁶⁶ The observed rate was fitted to the rate law for two consecutive, irreversible, first-order reactions (eq 115), it being assumed that there was no direct

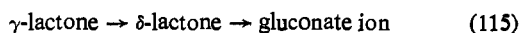

hydrolysis of the γ -lactone. Similar non-first-order behavior was observed in the hydrolysis of L-gulono- γ -lactone and D-xylono- γ -lactone. This interpretation received partial support when it was shown by Takahashi and Mitsumoto using paper chromatography⁷⁶⁷ and by Woodman using infrared spectroscopy⁷⁴⁵ that glucono- γ -lactone is converted into the δ -lactone at neutral pH's. It was also shown that δ -lactone is converted into γ -lactone, however, and hence the lactone interconversion is reversible, not irreversible as shown in eq 115, and it also seems likely that there is some direct hydrolysis of γ -lactone.⁷⁶⁷

This interconversion cannot proceed by ring opening followed by recyclization. The pK_a of gluconic acid is 3.81⁷⁴⁵ so that at pH 7 the thermodynamically stable species is the gluconate ion and hence at this pH once ring opening had occurred recyclization would not take place. The only reasonable pathway is that proposed by Jermyn involving intramolecular attack by a hydroxyl group to give a bicyclic intermediate (**302**), but the detailed mechanism is not known.

A similar interconversion of the mannonolactones has been investigated by studying the inhibiting power of their solutions for α -mannosidases.^{768,769}

The hydrolysis of aldonamides has been studied by Wolfrom, Bennett, and Crum using mainly, initially neutral, unbuffered solutions.^{770,771} Under these conditions it was found that the hydrolysis of ribonamide, galactonamide, mannonamide, and lyxonamide, but not gluconamide, showed complex kinetics with an induction period, but once this was over hydrolysis was much more rapid than the hydrolysis of acetamide. The induction period could be the result of a drift in pH resulting from a small amount of hydrolysis or from the adventitious intervention of metal ions, possibly leached from the glass of the polarimeter tube, and significantly no induction period was observed when the hydrolysis of galactonamide was studied in a metal polarimeter tube. It was suggested that the reaction proceeded *via* the δ -lactone as shown in eq 116 with neighboring group participation by the hydroxyl group at C(5). Participation by the hydroxyl group at C(4) with the reaction proceeding *via* a γ -lactone is also possible, and at present the proportions proceeding *via* these two pathways

cannot be assigned. In acid solution 5-hydroxyvaleramide is hydrolyzed 2.6 times faster than 4-hydroxybutyramide,⁷⁷² but with the aldonamides the relative rates of reactions proceeding with O(5) and O(6) participation may be influenced by the other hydroxyl substituents (see also ref 773).

The hydrolyses of aldose cyanohydrins proceed rapidly for hydrolyses of nitriles (*cf.* ref 774, 775) and also probably

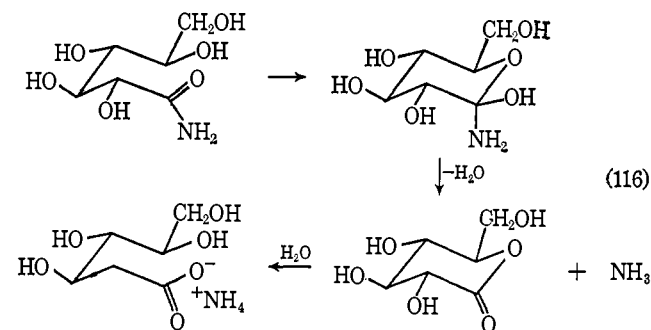

occur with neighboring group participation (see, *e.g.*, eq 117). Similar participation has been suggested to occur in the hydrolysis of nitrile **303**.⁸²¹

(768) G. A. Levvy, A. J. Hay, and J. Conchie, *Biochem. J.*, **91**, 378 (1964).

(769) J. Conchie, A. J. Hay, I. Strachan, and G. A. Levvy, *ibid.*, **102**, 929 (1967).

(770) M. L. Wolfrom, R. B. Bennett, and J. D. Crum, *J. Amer. Chem. Soc.*, **80**, 944 (1958).

(771) M. L. Wolfrom and R. B. Bennett, *J. Org. Chem.*, **30**, 1285 (1965).

(772) L. Zürrn, *Ann. Chem.*, **631**, 56 (1960).

(773) H. Kuzuhara and H. G. Fletcher, *J. Org. Chem.*, **32**, 2535 (1967).

(774) C. S. Hudson, *Advan. Carbohydr. Chem.*, **1**, 23 (1945).

(775) H. B. Wood and H. G. Fletcher, *J. Org. Chem.*, **26**, 1969 (1961).

(764) H. C. Brown, J. H. Brewster, and H. Schechter, *J. Amer. Chem. Soc.*, **76**, 467 (1954).

(765) R. U. Lemieux, in ref 36a, Part 2, p 719.

(766) M. A. Jermyn, *Biochim. Biophys. Acta*, **37**, 78 (1960).

(767) T. Takahashi and M. Mitsumoto, *Nature*, **199**, 765 (1963).

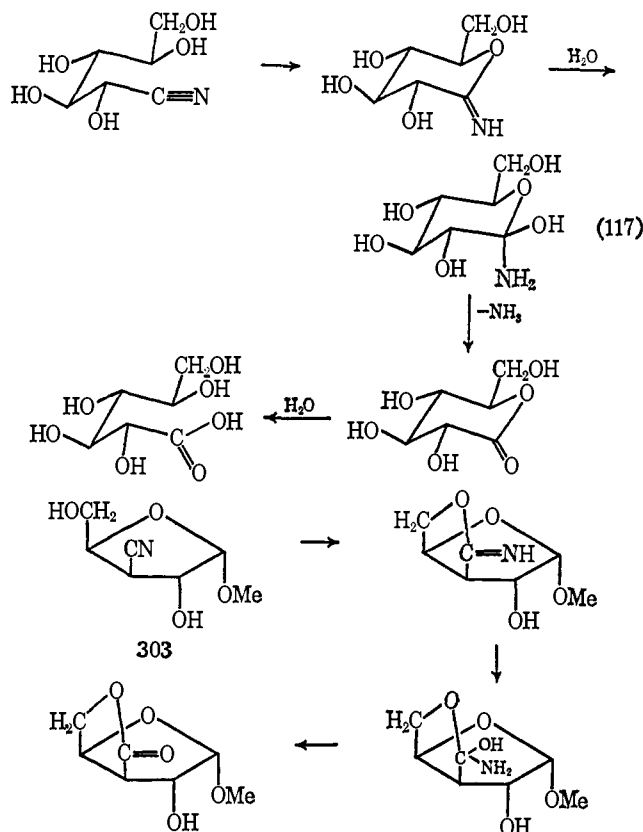
Table LXXI⁶¹

Lactone	γ -Lactone		δ -Lactone	
	% lactone at equi- librium	Half-life for hy- drolysis, hr	% lactone at equi- librium	Half-life for hy- drolysis, hr
Tetra- <i>O</i> -methyl- mannono	89.1	624	31.9	34
Tetra- <i>O</i> -methyl- glucono	24.3	216	21.6	2.5
Tetra- <i>O</i> -methyl- galactono	72.3	120	10.9	2
Tri- <i>O</i> -methyl- rhamnono	62.6	21
Tri- <i>O</i> -methyl- arabono	49.0	144	2.6	3
Tri- <i>O</i> -methyl- xylono	38.5	288	46.7	52
Mannono	81.5	264	61.6	12
Glucono	19.6	...	10.7	2
Galactono	75.4	292

Acknowledgments. I thank Dr. N. S. Anderson for reading the complete manuscript and making many valuable suggestions. I also thank Professor J. A. Thoma and Dr. R. J. Ferrier for allowing me to see copies of references 257 and 348b, respectively, before publication.

Addendum (Section V. B)

Rupley and his coworkers have studied the products of the reaction of tri-*N*-acetylchitotrioside in the presence of acceptors other than water and have so determined the selectivity of the product-forming intermediate. It was found that alcohols and phenols reacted substantially faster than sulfur nucleophiles (CH_3SH , H_2S), and this was considered to support the view that the intermediate was a carbonium ion rather than a covalently bound species.⁷⁷⁶ In the absence of information on the selectivity of the type of covalent species which have been postulated to be intermediates in lysozyme-catalyzed reactions, it is difficult to judge this contention. Although sulfur nucleophiles react more rapidly than analogous oxygen nucleophiles in substitution reactions of primary alkyl halides, it does not follow that this will be carried over to species for which the $\text{S}_\text{N}2$ transition state would be looser and more carbonium-ion like. Dahlquist, Rand-Meir, and Raftery⁷⁷⁷ have determined the α -deuterium isotope effect for the lysozyme-catalyzed hydrolysis of phenyl-4-*O*-(2-acetamido-2-deoxy- β -*D*-glucopyranosyl)- β -*D*-glucopyranoside to be $k_{\text{H}}/k_{\text{D}} = 1.11$. This should be compared with the α -deuterium isotope effects for the acid- and base-catalyzed hydrolyses of phenyl β -*D*-glucoside which are 1.13 and 1.03, respectively. Since the former reaction follows an A_1 mechanism and the latter involves neighboring group participation by an ionized hydroxyl group, the value of 1.11 for the lysozyme-catalyzed reaction suggests that the transition state has considerable carbonium-ion character. However, the substrate used in this work does not have a neighboring amide group and hence the mechanism of its hydrolysis could be different from that of a substrate with such a group. Also the base-catalyzed hydrolysis of phenyl β -*D*-glucoside is not a terribly good model for the nucleophilically assisted processes that have been postulated for the enzymically catalyzed reaction, since the nucleophile (the ionized hydroxyl group) is much stronger and the leaving group (the phenolate anion) is much poorer. The transition state for a reaction in which the nucleophile is a neighboring amide group or a carboxylate anion and the leaving group a partially protonated phenolate anion may be looser and lead to an isotope effect nearer that obtained for a carbonium-ion process. It is perhaps significant that a change in the α -deuterium isotope effect from 1.15 for the solvolysis of a series of 1-phenylethyl chlorides with electron-releasing substituents to 1.13 for the solvolysis of the *m*-bromo compound and 1.098 for the *p*-nitro compound has been interpreted as resulting from incursion of "nucleophilic attack on carbon in the rate-determining step."⁷⁷⁸

(776) J. A. Rupley, V. Gates, and R. Bilbrey, *J. Amer. Chem. Soc.*, **90**, 5633 (1968).

(777) F. W. Dahlquist, T. Rand-Meir, and M. A. Raftery, *Proc. Nat. Acad. Sci. U. S.*, **61**, 1194 (1968); see also F. W. Dahlquist and M. A. Raftery, *Biochemistry*, **7**, 3269, 3277 (1968); M. A. Raftery and T. Rand-Meir, *ibid.*, **7**, 3281 (1968).

(778) V. J. Shiner, W. E. Buddenbaum, B. L. Murr, and G. Lamaty, *J. Amer. Chem. Soc.*, **90**, 418 (1968).