

PHOTOLUMINESCENCE OF TRANSITION METAL COORDINATION COMPOUNDS

PAUL D. FLEISCHAUER^{1a} AND PATRICIA FLEISCHAUER^{1b}

Institute of General Chemistry, University of Rome, Rome, Italy 00185

Received June 24, 1969

Contents

I. Introduction	199
A. Energy States of Coordination Compounds	200
B. Kinetic Expressions for Excited-State Processes	201
II. Experimental. Peculiarities of Coordination Compounds	202
III. Compounds of d ⁰ and d ² Metal Ions	202
A. Niobium(V)	202
B. Zirconium(IV)	202
C. Vanadium(III)	202
D. Manganese(V)	203
IV. Compounds of d ³ Metal Ions	203
A. Ionic Complexes. Solid-State Considerations	203
B. Chromium(III) Molecular Complexes	204
1. Preliminary Reports	205
2. General Studies	206
3. Quantitative (Mechanistic) Results	207
4. Theoretical Implications	209
5. Energy-Transfer Studies	211
C. Other d ³ Metals	212
V. Compounds of d ⁵ Metal Ions	212
A. Ionic Complexes (Solid State and Glasses)	213
B. Molecular Complexes	216
VI. Compounds of d ⁶ Metal Ions	218
A. General Studies	219
B. Hexacyanide Complexes	219
C. Ruthenium(II)	220
1. Nitrogen Coordinated Heterocyclic Chelates	220
2. Mixed Ligand Complexes	220
D. Osmium(II)	221
E. Rhodium(III)	221
F. Iridium(III)	222
G. Platinum(IV)	222
VII. Compounds of the d ⁷ Metal Ion	222
A. Tetrahedral Complexes	223
B. Octahedral Complexes	224
VIII. Compounds of d ⁸ Metal Ions	224
A. Nickel(II)	225
B. Platinum(II)	225
1. Tetracyanide Complexes	225
2. Other Ligands	227
IX. Compounds of d ¹⁰ Metal Ions	228
X. Concluding Remarks	229
XI. Appendix	229

I. Introduction

The study of the physics and chemistry of the excited states of transition metal coordination compounds has developed rapidly through photochemistry, absorption and reflectance spectroscopy, and emission spectroscopy. Photochemistry has been reviewed recently,²⁻⁵ and absorption and reflectance spectroscopy are constantly being brought up to date in various books^{3,6,7} and monographs.⁸ A few years ago a review was published⁹ which summarized the luminescence studies for all metals up to 1963. The emission properties of chromium complexes have been treated as part of a general discussion of their spectra.⁶ Also, some fundamental aspects of the luminescence of various transition metal complexes have been discussed,¹⁰ and there are two series of reviews concerning the analytical uses of metal ion luminescence.¹¹ However, a comprehensive review of all the transition metals involving a thorough literature search has not been published. It is the purpose of this article to attempt such a task and to discuss the extensive amount of experimental material in terms of the mechanisms of energy transfer, intra- and intermolecular, radiative and nonradiative, in the various complex ion systems. Of the following eight types of molecular emission possible for a given substance [fluorescence, phosphorescence, E-type delayed fluorescence (temperature dependent), "sensitized" emission (includes X-ray, thermally and electrically induced as well as energy transfer), P-type delayed fluorescence (triplet annihilation), excimer fluorescence, delayed excimer fluorescence, and chemiluminescence], the first four have been observed so far for coordination compounds and are reviewed here. One example of the last type, chemiluminescence, will also be cited. For the literature search, *Chemical Abstracts* has been used up through 1968 and many journals have been examined individually.

(2) E. L. Wehry, *Quart. Rev.* (London), **21**, 213 (1967).

(3) F. Basolo and R. G. Pearson, "Mechanisms of Inorganic Reactions," 2nd ed, John Wiley and Sons, Inc., New York, N. Y., 1967.

(4) V. Balzani, L. Moggi, F. Scandola, and V. Carassiti, *Inorg. Chim. Acta Rev.*, **1**, 7 (1967); D. Valentine, *Advan. Photochem.*, **6**, 124 (1968).

(5) A. W. Adamson, W. L. Waltz, E. Zinato, D. W. Watts, P. D. Fleischauer, and R. D. Lindholm, *Chem. Rev.*, **68**, 541 (1968).

(6) L. S. Forster in "Transition Metal Chemistry," Vol. V, R. L. Carlin, Ed., Marcel Dekker, Inc., New York, N. Y., in press.

(7) K. Nakamoto and P. J. McCarthy, S. J., "Spectroscopy and Structure of Metal Chelate Compounds," John Wiley and Sons, Inc., New York, N. Y., 1968.

(8) A. B. P. Lever, "Physical Inorganic Chemistry," Elsevier Publishing Co., Amsterdam, 1968.

(9) G. B. Porter and H. L. Schlaefer, *Ber. Bunsenges. Physik. Chem.*, **68**, 316 (1964).

(10) G. Sartori, Proceedings of the XIth International Conference on Coordination Chemistry, Haifa, Israel, 1968.

(11) (a) M. Margoshes and B. F. Scribner, *Anal. Chem.*, **40**, 223R (1968); (b) C. E. White and A. Weissler, *ibid.*, 116R (1968).

(1) (a) U. S. National Science Foundation-National Research Council of Italy Postdoctoral Exchange Fellow, 1968-1969. Present address: Aerospace Corporation, El Segundo, Calif. 90045. (b) Present address: Rand Corporation, Santa Monica, Calif.

The general treatment of the subject matter will follow that of a previous review on photochemistry,⁵ although because of the nature of the studies reported the emphasis in classification of metals has been placed on their number of d electrons rather than on their group in the periodic table. Thus, for example, V(II), Cr(III), Mn(IV), and Mo(III) all are treated as d³ metal ions. After general classification each metal is discussed individually with emphasis on the specific energy states involved in absorption and emission of light, on molecular processes which may precede or occur simultaneously with emission, and on medium or environmental effects on the emissions. Included in most sections of this review will be one or more tables summarizing the important data for that section.

One subject not treated here is the luminescence of lanthanide complexes, because of the different nature of the accessible transitions (4f electronic states) involved in such compounds. For more information concerning this area the reader is referred to recent articles¹² and reviews.¹³

A. ENERGY STATES OF COORDINATION COMPOUNDS

The advantage of treating electronic energy levels of a metal complex as molecular states rather than individual metal and ligand states has been discussed.^{5,6} It is true, though, that a good description of the electronic structure of many complexes can be made using crystal field or, more successfully (and with more difficulty), ligand field theory. Usually, in either of these treatments, one considers the effects of a field¹⁴ produced by the ligands surrounding the metal ion on the otherwise degenerate metal d orbitals. Looking first at the metal ion without any field (*i.e.*, the "free gaseous metal ion"), one recognizes that the d electrons can couple their orbital- and spin-angular momenta to produce a series of different states,¹⁵ which are designated by different term symbols.¹⁵⁻¹⁷ These states result from the various possible combinations of the values of the orbital-angular momentum and spin-angular momentum quantum numbers. The ordering of the lowest states for a d³ metal¹⁸ is shown on the extreme left side of Figure 1. Hund's rules generally determine this ordering. A discussion of the method of coupling of the electrons and the relative ordering is given, among other places, in ref 17.

On the right side of Figure 1, the situation for the same d³ metal ion placed in an octahedral arrangement of ligands which produce a very strong field (actually a field of infinite magnitude) is diagrammed. The designations here (*i.e.*, $t_{2g}^m e_g^n$) refer to the placement of electrons in one or the other sets of one-electron d orbitals which result from the splitting produced by the ligand field. In O_h symmetry^{18,19} the three-fold degenerate t_{2g} orbitals are lower in energy than the two-fold degenerate e_g orbitals by an amount $10Dq$ (Δ). The two extreme cases may then be correlated by one of three different

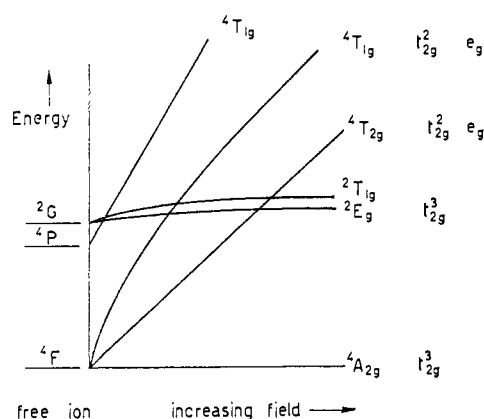

Figure 1. Schematic correlation diagram (lowest levels) for octahedral d³ metal complexes (after ref 18).

approximations, weak, medium, and strong field calculations.^{5,18} Using the appropriate approximate calculation, the energies of the states may be determined as functions of the field strength of the ligands.

A common practice when discussing the various energy levels of a coordination complex is to choose a point along the abscissa of a diagram, such as Figure 1, which represents the appropriate value of the term separation for the particular complex involved, and construct a new figure depicting the lowest states and showing their spacing. Figure 2 shows this, again for a d³ metal ion. (The displacement of the spin-forbidden states to the right of the spin-allowed ones has no physical significance and is done only for clarity in reading the diagram.) The magnitude of these separations can be expressed in terms of the parameters $10Dq$, B , and C for octahedral symmetry.^{6,20} $10Dq$ is the crystal field splitting of the d orbitals (*vide supra*), and B and C are the electron repulsion Racah parameters; the former applies to states of the same multiplicity while both are used for states of different multiplicity.

The treatment described above provides a framework for interpreting the d-d electronic transitions in a metal ion complex. (The terms coordination compound, coordination complex, and metal complex will be used interchangeably in this review, although the definition of such compounds is assumed to be the same as in the previous review.⁵) Admitting this approximation wherein the ligands are still considered only as perturbations to the d orbitals, we shall proceed to discuss briefly the other types of electronic transitions.

Transitions which result from the transfer of an electron from a primarily ligand orbital to a primarily metal orbital (designated CTTM, charge transfer to metal) and *vice versa* (CTTL, charge transfer to ligand) are called *charge transfer* (CT) transitions, and usually lie at higher energies than the d-d transitions. CT excited states can be very important in excitation (absorption) processes and, as shown in section VI, can sometimes be involved in luminescence.

A third type of excited state in a coordination complex is located predominantly on the ligand portion of the molecule and is usually considerably higher in energy than either d-d or CT excited states. Transitions to these ligand states in a complex molecule often differ little from the corresponding

(12) G. A. Crosby, *Mol. Cryst.*, **1**, 37 (1966).

(13) G. E. Peterson, *Transition Metal Chem.*, **3**, 202 (1966).

(14) This is either purely electrostatic or electrostatic plus covalent bonding.

(15) For definitions of these classifications see ref 16 or 17.

(16) L. E. Orgel, "An Introduction to Transition-Metal Chemistry and Ligand Field Theory," Methuen and Co., Ltd., London, 1960.

(17) C. J. Ballhausen, "Introduction to Ligand Field Theory," McGraw-Hill Book Co., Inc., New York, N. Y., 1962.

(18) L. E. Orgel, *J. Chem. Phys.*, **23**, 1004 (1955).

(19) F. A. Cotton, "Chemical Applications of Group Theory," Interscience Publishers, Inc., New York, N. Y., 1963.

(20) C. K. Jørgensen, "Absorption Spectra and Chemical Bonding in Complexes," Pergamon Press, London, 1962.

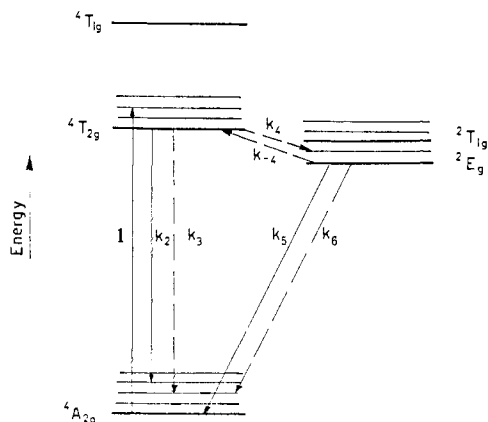

Figure 2. Level diagram for a typical d^3 complex in an O_h field, showing some processes which can occur after light absorption.

transitions of the free ligand. For some complexes, however, the lowest energy "ligand" absorption may not correspond to the lowest energy band in the free ligand. An organic molecule, which is a potential ligand, may have absorptions corresponding to the promotion of a nonbonding electron ($n-\pi^*$) or a π bonding electron ($\pi-\pi^*$) to a π antibonding orbital, the former being the lower energy transition. Since the nonbonding electrons become involved in the coordinate bond in a complex, the $n-\pi^*$ transition no longer exists but is a $\sigma-\pi^*$ transition. Because of the energy stabilization which results from the metal ligand bond energy, this latter absorption would be found at higher energies than the $\pi-\pi^*$. Ligand excited states are of interest since they can sometimes behave independently of the metal, while in other instances they mix with metal states resulting in the transfer of electronic energy from one to another transition in the molecular unit.

Finally, excited states resulting from the promotion of an electron from a metal or ligand orbital into a conduction or otherwise delocalized band (*i.e.*, electron hole transitions) can give rise to luminescence in transition metal compounds. This type of transition will not be treated here, since the phenomenon is generally associated with solid-state processes and often with simple metal salts, as opposed to coordination compounds. For further information on the subject the reader is referred to current reviews.²¹

B. KINETIC EXPRESSIONS FOR EXCITED-STATE PROCESSES

In order to derive and understand the kinetic relationships that are often used to describe processes occurring after the absorption of a quantum of light by a molecule, we have indicated in Figure 2 the more important of these processes with the corresponding rate constants. Each first-order rate constant represents the probability of the particular process and is defined in the usual kinetic fashion. For example, if there were only one process (k_4) populating and one process (k_5) depopulating the 2E state we would write the rate law

$$\frac{d[{}^2E]}{dt} = k_4[{}^4T_2] - k_5[{}^2E] \quad (1)$$

This rate law corresponds to the mechanism



In fact, depending on the relative importance of k_{-4} , there could be one or two additional terms involved in the above rate law. A similar law can be written for the rate of change in the concentration of the spin-allowed (4T_2) state where, for simplicity, it has been assumed that the only excitation is to 4T_2 . This excitation is expressed by the intensity of absorbed light I in units of quanta absorbed $\text{sec}^{-1} \text{cc}^{-1}$.

$$\frac{d[{}^2E]}{dt} = k_4[{}^4T_2] - k_5[{}^2E] - k_6[{}^2E] \quad (4)$$

$$\frac{d[{}^4T_2]}{dt} = I - k_2[{}^4T_2] - k_3[{}^4T_2] - k_4[{}^4T_2] \quad (5)$$

When constant illumination is employed the steady-state approximation may be assumed for the concentrations of molecules in each excited state. Setting eq 4 and 5 equal to zero and solving the expressions for the concentrations of each state, we obtain the following.

$$[{}^4T_2] = \frac{I}{k_2 + k_3 + k_4} \quad (6)$$

$$[{}^2E] = \frac{k_4 I}{(k_5 + k_6)(k_2 + k_3 + k_4)} \quad (7)$$

From these expressions and from the definitions for the quantum yields of fluorescence ($\phi_f = k_2[{}^4T_2]I^{-1}$, emission from a spin-allowed state) and phosphorescence ($\phi_p = k_5[{}^2E]I^{-1}$, emission from a spin-forbidden state), we can immediately write these quantum yields in terms of the probabilities of the various processes.

$$\phi_f = \frac{k_2}{k_2 + k_3 + k_4} \quad (8)$$

$$\phi_p = \frac{k_4 k_5}{(k_5 + k_6)(k_2 + k_3 + k_4)} \quad (9)$$

(The sum of ϕ_f , ϕ_p , and the yields for photochemical reactions and for all other deactivation processes equals one.)

By definition, the lifetime of an excited state is equal to the reciprocal of the total probability for depopulation of that state.²²

$$\tau_f = \frac{1}{k_2 + k_3 + k_4} \quad (10)$$

$$\tau_p = \frac{1}{k_5 + k_6} \quad (11)$$

It is thus apparent for the general case where k_{-4} is negligible that there are at best four experimental parameters and five probability constants. Under favorable conditions k_2 and/or k_5 can be determined from the absorption spectra;²³ however, most of the time the situation is complicated by the appearance of only one type of emission, or of temperature-dependent

(21) (a) J. G. Winans and E. J. Seldin in "Handbook of Physics," E. U. Condon and H. Odishaw, Ed., McGraw-Hill Book Co., New York, N. Y., 1967, Chapter 7, pp 6-131; (b) S. Shionoya in "Luminescence of Inorganic Solids," P. Goldberg, Ed., Academic Press, New York, N. Y., 1966, p 205; (c) Anonymous, *Bull. Acad. Sci. USSR, Phys. Ser.*, 23, 1271 (1959).

(22) P. Pringsheim, "Fluorescence and Phosphorescence," Interscience Publishers, Inc., New York, N. Y., 1963, p 3.

(23) See, for example, ref 5, eq 7.

emission. In addition, apparatus for the measurement of fluorescence lifetimes had been described²⁴ as early as 1960 but not applied to the study of transition metal compounds until recently. In light of the particular difficulties of each complex system, their energy states and kinetic properties will be discussed individually.

II. Experimental. Peculiarities of Coordination Compounds

It is not within the scope of this review to describe the large variety of apparatus available for luminescence studies. This subject is already treated in detail for investigations of organic systems.^{25, 26} In general the same apparatus can be used in the study of coordination compounds; however, there are a few specific details which need to be mentioned. We have pointed out that coordination compounds often absorb light of the medium and long wavelength visible portion (400–700 m μ) of the spectrum in d-d transitions.⁵ For this reason actinometers for measuring light intensities of these wavelengths are necessary and they have been described.²⁷ In addition, detectors capable of measuring radiation in the long visible and near-infrared portion (700–1200 m μ) of the spectrum are required for observing the luminescence. For this purpose one of two methods is usually applied: (1) spectrographic analysis of emission using any high-quality spectrograph with Kodak 103F, I-N, I-M, or I-Z (or their equivalents) photographic plates (λ 300–1200 m μ); (2) spectrofluorometric analysis using a long-wavelength analyzing monochromator and a photomultiplier tube with suitable spectral characteristics. Examples of the latter are R.C.A. 7102, DuMont 6911, or Phillips 150 CVP (all S-1 response). (It is always desirable to cool the photomultiplier, including voltage divider, to the temperature of liquid nitrogen vapors, about 90–100°K for greatly improved signal to noise ratios.) Some compounds will be described which emit in the shorter wavelength visible spectrum, and for these the conventional apparatus described for organic systems can be used.

For the spectral region from 1200 to 1400 m μ , a Jarrell-Ash 0.5-m grating monochromator (also good in visible) with a cooled Eastman-Kodak lead sulfide cell and a 13-cps Perkin-Elmer amplifier have been used successfully.²⁸ We are currently experimenting²⁹ with a single beam Perkin-Elmer 12-C infrared spectrophotometer equipped with a lead sulfide cell for measurements from 1.2 to 2.5 μ .

Other peculiarities of coordination compounds include the following: large number of multicolored stable compounds; highly variable solubility in glass forming solvents; photosensitivity in solid and liquid phases; and unusual, often paramagnetic, spin states in ground and excited electronic configurations. Transition metal complex ions which are often stable with respect to decomposition as solids can undergo very rapid substitution reactions in solutions. For this reason luminescence studies offer an opportunity to investigate the structure and properties of such complexes by virtue of the

fact that they may be performed with solid (crystalline or powder) samples as well as solutions (liquid and glass). Complexes can be anionic, neutral, or cationic, depending on composition; and as a result may or may not be soluble in glass forming solvents. It is customary to employ glassy solvents for low-temperature studies to avoid cracking of the sample (and consequent light scattering), and to approximate medium conditions at higher temperatures. The photosensitivity of these compounds need not be dwelt upon.⁵ This property can be a hazard for luminescence studies, but luminescence can also be used to monitor photochemical reactions; for example, when a reactant or product luminesces, the concentration of emitting species can be followed using emission measurements. (In fact the photosensitivity of [Pt(dipy)₂]Cl₂ was first recognized by observing changes in its luminescence; one peak diminishes and another appears.²⁹) The ground and excited states of metal complexes can have widely varying spin multiplicity. Cr(III) in an octahedral coordination sphere, for example, is paramagnetic and has a total spin in the ground state of $3/2$. These factors could be important in consideration of the spin-orbit coupling in a manifold of ligand excited states.³⁰

III. Compounds of d⁰ and d² Metal Ions

Although d⁰ and d² are not common electronic configurations, a few examples of the luminescence of metal complexes of these configurations have been found. In section IX we will discuss p \leftarrow d absorptions, the reverse of which gives emission; for d⁰ the opposite is possible. In the formalism of ligand field or molecular orbital theory the absorption corresponds to a CTM transition.

A. NIOBIUM(V)

When Nb(V) is added to antimonates such as Li₃SbO₄, a new emission band is observed which is attributed to a 4d_{Nb} \rightarrow 2p_{O²⁻} transition.³¹ In the ground state the Nb(V) ion has no d electrons but is in a crystalline field of oxide ions. The lowest observed absorption in these compounds corresponds to an electron transfer from an oxygen p orbital to an empty niobium d orbital. A series of papers has been published (ref 31 is the latest) comparing this d \rightarrow p emission with the p or s \rightarrow d emission observed in 3d¹⁰ or 3d⁹4s (Cu⁺) compounds.

B. ZIRCONIUM(IV)

The only other reports found for a d⁰ metal concern Zr(IV) chelate complexes.^{32, 33} Although the transitions responsible for emission may be charge transfer similar to that in the Nb(V) example, it is more likely that they are ligand ($\pi^* \rightarrow \pi$) transitions, as in some Sc(III) and rare earth chelates.

C. VANADIUM(III)

Two reports of the luminescence of d² metals were found. While the first does involve the zinc sulfide type of environment the infrared emission of V(III) is treated in terms of

(24) (a) R. G. Bennett, *Rev. Sci. Instrum.*, **31**, 1275 (1960); see also (b) M. Mack, *J. Appl. Phys.*, **39**, 2483 (1968); (c) G. Porter and M. R. Topp, *Nature*, **220**, 1228 (1968).

(25) D. M. Hercules, Ed., "Fluorescence and Phosphorescence Analysis," Interscience Publishers, New York, N. Y., 1966, Chapter 2.

(26) C. A. Parker, "Photoluminescence of Solutions," Elsevier Publishing Co., Amsterdam, 1968, Chapter 3.

(27) E. E. Wegner and A. W. Adamson, *J. Amer. Chem. Soc.*, **88**, 394 (1966).

(28) J. E. Ralph and M. G. Townsend, *J. Chem. Phys.*, **48**, 149 (1968).

(29) D. L. Webb and P. D. Fleischauer, unpublished results.

(30) J. G. Calvert and J. N. Pitts, Jr., "Photochemistry," John Wiley and Sons, Inc., New York, N. Y., 1966.

(31) G. Blasse, *J. Chem. Phys.*, **48**, 3108 (1968).

(32) C. E. White, D. E. Hoffman, and J. S. Magee, Jr., *Spectrochim. Acta*, **9**, 105 (1957).

(33) E. A. Bozhevol'nov, A. G. Monakhova, and G. V. Serebryakova, *Metody Analiza Khim. Reaktivov i Preparatov*, **11**, 93 (1965); *Chem. Abstr.*, **65**, 1381f (1966).

crystal field theory and does apply to this review. If V^{3+} is doped into ZnS, ZnSe, CdS, or CdSe, it is in a tetrahedral field of sulfur or selenium ions. The possible splitting patterns of the electronic energy states of d^2 and d^3 ions have been treated theoretically, and the transition energies were compared to the observed absorptions and emission.³⁴ It was concluded that vanadium is trivalent (d^2) and the observed absorptions correspond to transitions from 3A_2 ground state to 3T_2 , ${}^3T_1(F)$, and ${}^3T_1(P)$ excited states. The emission is then from the lowest energy excited state 3T_2 to the ground 3A_2 state.

D. MANGANESE(V)

The tetrahedral MnO_4^{3-} (d^2) ion exists in solution and in place of PO_4^{3-} in the doped salts Ca_2PO_4Cl and $Ca_3(PO_4)_2Cl$.³⁵ The ground state of Mn^{5+} is 3A_2 as above; however, in the solid compounds, spin-forbidden ${}^1E \leftarrow {}^3A_2$ and ${}^1A_1 \leftarrow {}^3A_2$ transitions which are within the e^2 configuration are observed in absorption, and the former also in emission. The ${}^1E \leftrightarrow {}^3A_2$ transition has two components in absorption and emission which result from splitting of the excited state either by lower symmetry of the ion or by spin-orbit coupling. The higher energy component of emission is the weaker and decreases in intensity on cooling, while the low energy emission and absorption are coincident. The splitting of the 1E state is quite large, from 166 to 293 cm^{-1} . In addition there is some vibronic structure on the low energy side of the emission. The decay time for the emission, ~ 1 msec, is the right magnitude for phosphorescence.

Table I

Absorption and Emission Spectral Maxima for d^0 and d^2 Metal Compounds (Selected Data)

Compound	Absorption or excitation max, kK	Assignment ^a	Emission max, kK	Ref
$Li_3SbO_4:Nb^{5+}$	42.0	$4d \rightarrow 2p(O^{2-})$	25.0	31
$LiSbO_3:Nb^{5+}$	38.8	$4d \rightarrow 2p(O^{2-})$	22.5	31
$CaSb_2O_6:Nb^{5+}$	41.4	$4d \rightarrow 2p(O^{2-})$	24.4	31
$SrSb_2O_6:Nb^{5+}$	38.0	$4d \rightarrow 2p(O^{2-})$	23.2	31
$BaSb_2O_6:Nb^{5+}$	37.3	$4d \rightarrow 2p(O^{2-})$	23.0	31
$MgSb_2O_6:Nb^{5+}$	36.0	$4d \rightarrow 2p(O^{2-})$	19.1	31
$Mg_2Sb_2O_5:Nb^{5+}$	35.1	$4d \rightarrow 2p(O^{2-})$	18.9	31
Zr(IV) flavonol	25 (sh) 28.99 40.81	?	21.50	32
V^{3+} in ZnS	9.09	${}^3T_2 \leftrightarrow {}^3A_2$	ir	34
V^{3+} in ZnSe	14.08	${}^3T_1(F) \leftarrow {}^3A_2$		
$Ca_3(PO_4)_2Cl$: MnO_4^{3-}	8.598 8.764	${}^1E \leftrightarrow {}^3A_2^b$	8.598 (st) ^c 8.764 (w)	35
$Ca_3(PO_4)_2F$: MnO_4^{3-}		${}^1E \leftrightarrow {}^3A_2^b$	8.640 (st) 8.750 (m)	35
Ca_2PO_4Cl : MnO_4^{3-}	8.410 8.703	${}^1E \leftrightarrow {}^3A_2^b$	8.410 (st) 8.703 (w)	35

^a Transitions always written with ground state on the right. ^b 1E state split into two components. ^c Designations of intensity, st = strong, m = medium, w = weak.

IV. Compounds of d^3 Metal Ions

Coordination compounds of metals of the d^3 electronic structure constitute the largest group studied to date. It has been pointed out⁶ that investigations of Cr(III) and other d^3 metal ions can be classified into those of ionic and those of molecular complexes. The ionic complexes are a special group which exist only in the solid phase, losing their identity when dissolved in solution. The complexes familiar to most coordination chemists are the molecular ones which, aside from possible substitution reactions, retain their identity in solid and solution. They can, of course, be charged (*e.g.*, $Cr(NH_3)_6^{3+}$, $Cr(ox)_3^{3-}$), or neutral ($Cr(aca)_3$).³⁶ The emission of the ionic complex $Cr^{3+}:Al_2O_3$ (ruby) was one of the first examples of emission of a coordination compound³⁷ and is still of primary interest, especially in industrial applications (lasers). For this reason, and because much of the information learned in solid-state studies has been carried over to studies of molecular complexes, we have chosen to give a brief account of some aspects of the luminescence of some ionic complexes.

A. IONIC COMPLEXES. SOLID-STATE CONSIDERATIONS

$V(II)$, $Cr(III)$, and $Mn(IV)$ ions may be doped into a number of transparent metal oxide crystalline hosts (MgO , Al_2O_3 , spinels) resulting in very bright colors to these solids. The guest ion is always oxygen-coordinated with six nearest neighbors, and may be in an octahedral (MgO) or a distorted octahedral (D_3 , Al_2O_3) symmetry site. As a result of the crystal field of the host, the d orbitals of the guest are split in a manner similar to that described above and shown in Figures 1 and 2. The intensities and types of electronic transitions between the energy states formed from the d orbitals depend on the symmetry site and on the spin multiplicities of the states. The transitions may be either magnetic or electric dipole and may be parity and/or symmetry allowed or forbidden.⁶ Emission from spin-forbidden (2E) and spin-allowed (4T_2) states has been observed. For additional material the reader is directed to reviews^{6,9,38} and to the many references given in the articles mentioned below.

The excited states in d^3 metal ions can be further split in energy by reductions (from O_h) in the symmetry of the field around the metal or by spin-orbit coupling. These reductions may result from existing variations in crystal structure (see, for example, the two spectra reported on pp 640 and 641 of ref 39 for MgO and Al_2O_3 hosts) or from external effects such as the application of very high pressures along a crystal axis.^{40,41} Variation of the axis along which pressure is applied in $MgO:V^{2+}$ can cause either trigonal or tetragonal splitting of the 2E_g state.⁴⁰

The splitting of the 2E state in ruby results in the appearance of two phosphorescence lines, one from each component. In early work this pair of lines was referred to as the "chromium doublet," and it is interesting to note that the excited states involved in the emission are indeed spin doublet states. The

(36) See Appendix for definitions of all abbreviations used for ligands.

(37) O. Deutschbein, *Ann. Physik.*, **36**, 183 (1939).

(38) (a) D. S. McClure, *Solid State Phys.*, **9**, 490 (1959); (b) J. Margerie, *J. Phys. (Paris)*, **26**, 268 (1965).

(39) M. D. Sturge, *Phys. Rev.*, **130**, 639 (1963).

(40) M. D. Sturge, *ibid.*, **131**, 1456 (1963).

(41) B. Henderson and T. P. P. Hall, *Proc. Phys. Soc.*, **90**, 511 (1967).

(34) J. W. Allen, *Physica*, **29**, 764 (1963).

(35) J. D. Kingsley, J. S. Prener, and B. Segall, *Phys. Rev.*, [A] **137**, 189 (1965).

term doublet state of chromium is now widely used to refer to the lowest spin-forbidden state and should not be confused with the original "chromium doublet" which is not a state but a pair of lines in the absorption or emission spectrum.

In a recent study of molecular complexes ($\text{Cr}(\text{OH}_2)_6^{3+}$ and $\text{Cr}(\text{OD}_2)_6^{3+}$) in the solid state, it has been demonstrated that two equal intensity peaks in absorption and emission can result from the ${}^2\text{E}$ transition when the chromium centers are in slightly different symmetry sites.⁴² According to this mechanism the relative intensities of the two emission peaks will not vary with temperature. If, on the other hand, the two peaks arise from a splitting of the excited state (ruby) the intensity of the higher energy one will decrease relative to the lower as the temperature is decreased, because of depopulation of the higher level. In the molecular complexes cited in ref 42 the intensity ratios remain constant from 4 to 77°K; the splitting of the bands is 16–17 cm^{-1} .

The phosphorescence spectra of d^3 solid-state complexes is characterized by very narrow bands in the red or near-infrared portions of the spectrum. These bands can show some asymmetry due to vibrational fine structure and, in the case of chromium, to the natural abundance of at least three nuclear isotopes.⁴³ The different masses of the isotopes result in different values for the vibrational frequencies, and thus in slightly different energies for the vibronic transitions. The effect is extremely small, 0.13 to 0.17 cm^{-1} , and shows the very high degree of precision with which these spectra can be measured. (Unfortunately, it has not been possible always to achieve this degree of precision in luminescence measurements of coordination compounds.) The temperature and light polarization dependencies of the vibrational structure of the phosphorescence have been studied and have been used to show the existence of electric dipole, magnetic dipole, and vibronic transitions.^{44–46} Also, a number of publications report the lifetimes and temperature dependencies of various oxides and glasses containing the Cr^{3+} ion.^{47–53}

The phosphorescence of V(II) in MgO has been used to measure its excitation spectrum and to obtain its ligand field parameters.⁵⁴ From these results the assignments of ${}^2\text{E}$, ${}^2\text{T}_1$, ${}^2\text{T}_2$, ${}^4\text{T}_2$, ${}^4\text{T}_1(\text{F})$, and ${}^4\text{T}_1(\text{P})$ were made, a task which is impossible in normal absorption measurements owing to the intense absorption spectrum of V(III) ion impurities, which are virtually impossible to remove. Also the polarized activation spectra, showing some vibrational fine structure in the ${}^4\text{T}_2$ band, were measured for V^{2+} in Al_2O_3 . The lifetime of the ${}^2\text{E}$

state of V^{2+} in MgO and Al_2O_3 was found to be much longer than those^{59, 54} of Cr^{3+} or Mn^{4+} in Al_2O_3 (see Table II).

A very recent discussion of the phosphorescence of Cr^{3+} in the spinels ZnAl_2O_4 and MgAl_2O_4 has been published.⁵⁵ Again crystal field parameters were calculated and vibrational fine structure was reported.

Al_2O_3 and MgO containing Mn^{4+} have been mentioned above.^{41, 54} Other studies of Mn^{4+} have dealt with its emission from magnesium and zinc titanate spinels,^{56, 57} its activation spectrum in a series of oxides,⁵⁸ and its emission from fluorogermanate glasses.⁵⁹ Both phosphorescence and fluorescence were observed for the Mn^{4+} doped titanates at 77°K but the spin-allowed emission was absent⁵⁶ at 4.2°K. The presence of temperature-dependent fluorescence of d^3 metals is also known for molecular complexes and is discussed in detail in section B.2. The emission of Mn^{4+} in fluorogermanate glasses was originally assigned as ${}^4\text{T}_2 \rightarrow {}^4\text{A}_2$ fluorescence,⁵⁹ but from its spectral position, shape (vibrational structure), and lifetime (3.48 msec at -125°), we feel a better assignment would be ${}^2\text{E} \rightarrow {}^4\text{A}_2$ phosphorescence.

In concluding this section we should like to point out that frequent reference is made to *fluorescence* of Cr^{3+} when discussing the emission from the ${}^2\text{E}$ to the ${}^4\text{A}_2$ state. By current definition, a spin-forbidden emission is called phosphorescence. In older literature phosphorescence was distinguished from fluorescence only on a time scale. While it is generally true that spin-forbidden states have longer lifetimes than spin-allowed states, it is not true that phosphorescence must have a decay time greater than 10^{-8} sec nor that fluorescence lasts less than 10^{-8} sec. Indeed, some chromium complexes have phosphorescence lifetimes of about 10^{-7} sec, and some heavier metal complexes (Ru(II)) have lifetimes of about 10^{-7} sec, which do not render a clear distinction between fluorescence and phosphorescence.

B. CHROMIUM(III) MOLECULAR COMPLEXES

The vast number of Cr(III) coordination compounds, which are relatively easily prepared and are stable with respect to decomposition, partially accounts for the very extensive research that has been performed with them in all areas of physical chemistry. Descriptions of kinetic and thermodynamic investigations abound in the literature,³ and more photochemical studies have been performed with Cr(III) complexes than with any other metal.⁵ Likewise more luminescence measurements have been reported for the complexes of this element than for any other metal. These complexes include ligands coordinated *via* nitrogen, oxygen, halogen, carbon, sulfur, and even selenium atoms. Measurements have been made on solid (powder and crystal) and solution (liquid and glass) samples at temperatures ranging from 4 to 300°K. Practically every aspect of luminescence spectroscopy has been treated including direct and indirect (*i.e.*, photosensitized) excitation, analysis of fine structure, lifetime, quantum yield, and temperature dependence studies.

(42) F. Diomedei Camassei and L. S. Forster, private communication.

(43) G. F. Imbusch, W. M. Yen, A. L. Schawlow, G. E. Devlin, and J. P. Remeika, *Phys. Rev.*, **136A**, 481 (1964).

(44) S. Sugano, A. L. Schawlow, and F. Varsanyi, *ibid.*, **120**, 2045 (1960).

(45) G. F. Imbusch, W. M. Yen, A. L. Schawlow, D. E. McCumber, and M. D. Sturge, *ibid.*, **133A**, 1029 (1964).

(46) D. F. Nelson and M. D. Sturge, *ibid.*, [A] **137**, 1117 (1965).

(47) A. K. Trofimov, *Dokl. Akad. Nauk SSSR*, **108**, 277 (1956); *Chem. Abstr.*, **51**, 1760i (1957).

(48) N. A. Tolstoi and S. F. Liu, *Opt. Spectrosc.*, **12**, 417; **13**, 61, 224 (1962); **14**, 25 (1963).

(49) N. A. Tolstoi, S. F. Liu, and M. E. Lapidus, *ibid.*, **13**, 133 (1962).

(50) G. Burns and B. A. Jenkins, *J. Appl. Phys.*, **37**, 4299 (1966).

(51) D. L. Wood, *J. Chem. Phys.*, **42**, 3404 (1965).

(52) M. M. Zaripov, V. S. Kropotov, L. D. Livanova, A. L. Stolov, and Zh. S. Yakovleva, *Fiz. Tverd. Tela*, **8**, 3680 (1966); *Chem. Abstr.*, **66**, 10052z (1967).

(53) G. O. Karapetyan, S. G. Lunter, and D. M. Yudin, *Opt. Spectrosc.*, **14**, 370 (1963).

(54) S. Geschwind, F. Kisliuk, M. P. Klein, J. P. Remeika, and D. L. Wood, *Phys. Rev.*, **126**, 1685 (1962).

(55) D. L. Wood, G. F. Imbusch, R. M. MacFarlane, P. Kisliuk, and D. M. Larkin, *J. Chem. Phys.*, **48**, 5255 (1968).

(56) R. Dittmann and D. Hahn, *Z. Phys.*, **207**, 484 (1967).

(57) A. Louat and F. Gaume-Mahn, *C. R. Acad. Sci., Paris, Ser. A, B*, **266B**, 1128 (1968).

(58) A. Louat and F. Gaume-Mahn, *ibid.*, **265B**, 1199 (1967).

(59) G. Kemeny and C. H. Haake, *J. Chem. Phys.*, **33**, 783 (1960).

Table II
Emission Spectral Maxima for Ionic d³ Metal Compounds (Solid State—Selected Data)

Compound ^a	Emission from ^b			² E, ^d unsplit	Ref
	⁴ T ₂	R ₁ ^{c,d}	R ₂ ^{c,d}		
V ²⁺ in					
MgO (77°K)				11.498 (50)	39, 40
MgO (293°K)				11.486 (25)	39
Al ₂ O ₃		11.679 (70)	11.691 (70)		39
Cr ³⁺ in					
MgO (4.2°K)				14.32	44
Al ₂ O ₃ (ruby)	14.2 ^e	14.405 (4.3)	14.436 (4.3)		46, 47, 92
Ga ₂ O ₃		14.368	14.524		48
Zn } Al ₂ O ₄		14.605	14.609		47, 55
Mg }					
BeAl ₂ O ₄		14.734	14.771		47
LaAlO ₃		13.627	13.632		50
LaGaO ₃		13.739	13.763		50
YAlO ₃		13.812	13.859		50
Emerald	13.6 ^f	14.654	14.717		51, 92
MgF ₂	12.82				52
GASH		14.092	14.109		42
GASD		14.081	14.097		42
AlCl ₃ ·6H ₂ O				14.555	42
AlCl ₃ ·6D ₂ O				14.560	42
40BaO·60SiO ₂	~11.78				53
40BaO·60B ₂ O ₃	~11.90			~14.50	53
25K ₂ O·25BaO·50B ₂ O ₃	~11.90			~14.30	53
25Na ₂ O·25BaO·50B ₂ O ₃	12.05			14.30	53
1/3Na ₂ O·2/3B ₂ O ₃	12.20			14.40	53
1/3K ₂ O·2/3B ₂ O ₃	12.20			14.40	53
Mn ⁴⁺ in					
MgO				15.28	41
Al ₂ O ₃		14.786 (0.8)	14.866 (0.8)		54
Mg ₂ TiO ₄	14.4–15.2	15.251	15.304		57
Mg ₂ TiO ₄ (4.2°K)	~15.08	~15.16	~15.34		56
Mg } ₂ TiO ₄ (4.2°K)	~14.77	~15.00	~15.08		56
Zn }					
Zn ₂ TiO ₄ (4.2°K)	~14.60	~14.9	~15.0		56
MgTiO ₃	13.5–14.2	14.291	14.322		57
Mg fluorogermanate		15.18 ^g (3.48)	15.85 ^g		59

^a If temperature is not specified it is assumed to be 77°K. ^b Approximate values were taken from graphs. All values in kK. ^c R₁ and R₂ are the two components of the ²E state (*i.e.*, the "chromium doublet"). ^d Lifetimes in msec are given in parentheses. ^e Fluorescence observed at 550°K. ^f Fluorescence observed at 300°K. ^g See text for an explanation of this assignment.

For organizational purposes we have divided the available information into five categories: (1) preliminary reports, (2) general studies, (3) quantitative (mechanistic) results, (4) theoretical implications, and (5) energy-transfer studies. Certainly these subjects are not mutually exclusive, but we hope that this particular organization will help the reader find the information he desires most easily.

1. Preliminary Reports

To a first approximation (*i.e.*, excluding the effects of covalent metal–ligand bonding), the splitting of the d orbitals of Cr(III) is the same for molecular and ionic complexes (see Figures 1 and 2). A large number of complexes in both solid and solution are of octahedral symmetry and those that are not are usually treated as distorted octahedra. Theoretically, both fluorescence and phosphorescence of Cr(III) are possible, depending on the values of the constants k_2 – k_6 in Figure 2.

Very fortunately indeed, one of the first complexes⁶⁰ to be investigated, [Cr(urea)₆](ClO₄)₃, exhibited both types of luminescence (see Figure 3). Following this early discovery 4 years elapsed before other Cr(III) complexes, which exhibited significant fluorescence in addition to or in place of the often seen phosphorescence, were reported.^{61,62} One might question whether so much interest would have been shown in chromium complexes if that early observation had not been made.

In the first report⁶³ of luminescence from a molecular Cr(III) complex the authors discussed the phosphorescence of Cr(aca)₃ and Cr(hq)₃. The compounds were dissolved in organic glass-forming solvents and chilled to 90°K. It was re-

(60) G. B. Porter and H. L. Schlaefler, *Z. Phys. Chem.* (Frankfurt am Main), **37**, 109 (1963).

(61) H. L. Schlaefler, H. Gausmann, and H. U. Zander, *Inorg. Chem.*, **6**, 1528 (1967).

(62) H. L. Schlaefler, H. Gausmann, and H. Witzke, *J. Chem. Phys.*, **46**, 1423 (1967).

(63) L. S. Forster and K. DeArmond, *ibid.*, **34**, 2193 (1961).

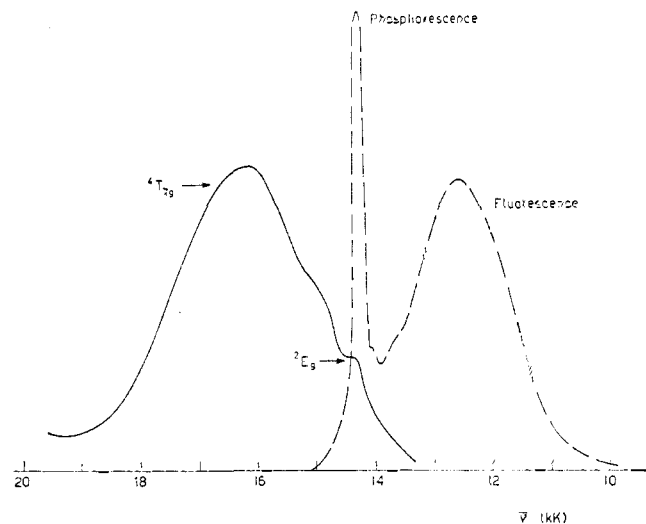

Figure 3. Absorption (—, 298°K) and emission (---, 77°K) spectra of $\text{Cr}(\text{urea})_6^{3+}$ (after ref 60).

ported that the emission did not depend on the wavelength of exciting light over the range 366–546 $m\mu$, which indicated very rapid conversion to the lowest excited state in the molecule after absorption. The following four points were pertinent to the spectroscopic assignment of the emission: (1) $\bar{\nu}_{\text{max}}$ was the same for both complexes, (2) the half-width of the emission band was much less than that of the first absorption band observed (${}^4T_2 \leftarrow {}^4A_2$), (3) there was a separation of about 2kK between absorption and emission, and (4) the decay time of the emission was about 0.4 msec. At the time of the preliminary report the authors were dubious as to whether the emission was ${}^4T_2 \rightarrow {}^4A_2$ or ${}^2E \rightarrow {}^4A_2$, but later unambiguously assigned it to 2E phosphorescence.⁶⁴

In the later study an extensive investigation of the absorption and emission spectra of a large series of β -diketone Cr(III) complexes was conducted.^{64–66} The first article⁶⁵ dealt with the absorption spectra and the assignment of the various transitions in the visible and near-ultraviolet. It was pointed out that absorption of light in a primarily ligand ($\pi^* \leftarrow \pi$) transition can lead to metal ion phosphorescence. This is an example of the very interesting topic of intramolecular energy transfer⁶⁷ and will be discussed in detail in the final section of this chapter.

2. General Studies

Shortly after the general investigation of β -diketone complexes, a very comprehensive report of octahedral, distorted octahedral, monodentate, and chelated Cr(III) complexes was published.⁶⁸ (Although published in a German journal, this and other articles of the authors are written in English.) Part of this work included the study of the now classic chromium luminophor, $\text{Cr}(\text{urea})_6^{3+}$, referred to above.⁶⁰ The absorption

and emission spectra of this compound (Figure 3) exhibit some very interesting features of the excited states of the Cr(III) ion. The positions of the maxima of absorption and emission for the 2E_g state are at the same frequency, while those of the 4T_2 are separated by approximately 3700 cm^{-1} . The explanation for this is that the 2E_g transition involves only a change in electron spin and not angular coordinates. Therefore there is negligible change in bond order of Cr(III) and, as a result, negligible change in internuclear distances between Cr(III) and the ligands. Excitation of the 4T_2 state, on the other hand, involves promotion of an electron from a nonbonding (or sometimes π bonding) level to a σ antibonding level (that is, from an orbital directed between the ligands, $d_{xy, xz, yz}$, to one directed at them, $d_{x^2-y^2, z^2}$). In this case there should be noticeable changes in bond order and in internuclear distances. The Franck–Condon principle then requires that absorption be to excited vibrational levels of 4T_2 , and emission be from the zero vibrational level of 4T_2 to excited vibrational levels of 4A_2 . Figure 4 is a good approximation only for a diatomic molecule, but it can be used to schematically represent the situation for a totally symmetric vibration in an octahedral complex. This drawing, representing the distortion of the 4T_2 state, shows that if emission occurs after thermal equilibration it will be at much lower energy than absorption. The highest energy emission and the lowest energy absorption, the origin (0–0 transition) for ${}^4T_2 \leftrightarrow {}^4A_2$, should be at the energy where the normalized emission and absorption curves cross.

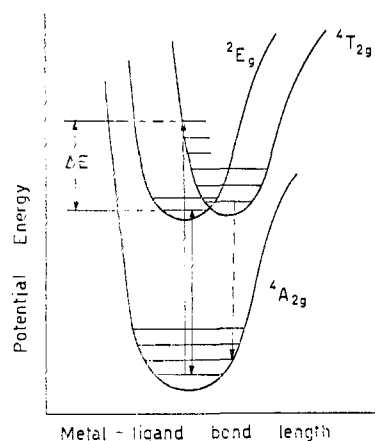

Figure 4. Schematic representation of a cut through the lowest potential energy surfaces in an octahedral d^8 complex, showing absorption (—) and emission (---) of ${}^4T_{2g}$ and (—) of 2E_g . Changes in bond length are for a totally symmetric skeletal vibration.

In the study of $\text{Cr}(\text{urea})_6^{3+}$ the temperature dependence of each of the two different bands was reported and then discussed further in a later publication.⁶⁹ The fluorescence intensity was found to decrease less rapidly with increasing temperatures than that of the phosphorescence, indicating either that k_{-4} (Figure 2) is significant or that k_3 is less temperature sensitive than k_6 . Considering another report, that of the complete disappearance of fluorescence at lower temperatures,⁷⁰ we suggest that k_{-4} is the more important temperature-

(64) K. DeArmond and L. S. Forster, *Spectrochim. Acta*, **19**, 1403 (1963).

(65) K. DeArmond and L. S. Forster, *ibid.*, **19**, 1393 (1963).

(66) K. DeArmond and L. S. Forster, *ibid.*, **19**, 1687 (1963).

(67) (a) G. A. Crosby and R. E. Whan, *J. Chem. Phys.*, **36**, 863 (1962), and preceding papers; (b) M. L. Bhaumik and M. A. El-Sayed, *J. Phys. Chem.*, **69**, 275 (1965).

(68) G. B. Porter and H. L. Schlaefer, *Z. Phys. Chem. (Frankfurt am Main)*, **40**, 280 (1964).

(69) D. M. Klassen and H. L. Schlaefer, *Ber. Bunsenges. Physik. Chem.*, **72**, 663 (1968).

(70) H. Gausmann and H. L. Schlaefer, *J. Chem. Phys.*, **48**, 4056 (1968).

dependent path. (See also the portion of section B.2 on temperature-dependence studies.) It is noteworthy that in the first two investigations^{60,69} band maxima instead of integrated emission intensities were used for the determination of temperature dependence. Nevertheless, because of the necessarily wide spectrograph slits, considerable portions of the peaks were involved in the intensity measurements and the conclusions are undoubtedly correct.

The general investigation referred to at the beginning of this section⁶⁸ included the results of phosphorescence measurements of a large number of complexes. For all of these complexes the Racah B_{55} parameter (see section B.3) was calculated and comments were made on nitrogen or oxygen to chromium bonding. Vibrational fine structure was resolved for many of the complexes and many of them have received additional attention in subsequent studies. We shall discuss these studies separately on the basis of the more detailed information in the appropriate sections. All of the compounds are summarized in Table VI.

3. Quantitative (Mechanistic) Results

Under this general heading there are three categories of work discussed, vibrational and polarization, lifetime and quantum yield, and temperature-dependence measurements. For any centrosymmetric complex the d-d electronic transitions are electric dipole forbidden.⁶ They are usually observed, however, because of reductions of molecular symmetry. This may be accomplished by static distortions such as those found in tris chelate complexes, or by interaction with molecular vibrations. In the latter case the interactions are usually with the excited electronic state and result in so-called vibronic transitions. Even for a vibronic mechanism the 0-0 transition is forbidden. When observed it is often very weak and is probably a magnetic dipole transition. Therefore, the search for and study of the vibrational structure of absorption and emission spectra and assignment of the 0-0 transitions are critical for an understanding of the type of electronic (electric or magnetic dipole, etc.) transition involved.

The first detailed study of the vibrational fine structure of a Cr(III) complex concerned the ion $\text{Cr}(\text{tn})_3^{3+}$, where structure was observed in both absorption and emission.⁷¹ In the absorption spectrum the vibrations observed are of the excited electronic state (2E), while in emission they are of the ground electronic state (4A_2). The spacings between peaks and/or shoulders are almost the same in absorption and emission and they correspond to certain absorptions found in the infrared spectrum. This means that only one electronic transition is involved (*i.e.*, the 2E state is not split by the reduced D_3 symmetry), and that this electronic transition (*i.e.*, a change in spin of one electron) does not affect the metal-ligand bonding to any significant extent. (This conclusion may be true in the case of saturated ligands but is doubtless an oversimplification when the three t_{2g} Cr(III) electrons are involved in π bonding with the ligands.) In $\text{Cr}(\text{tn})_3^{3+}$, as in $\text{Cr}(\text{en})_3^{3+}$, static distortions are apparently more important than the vibronic mechanism in adding intensity to the doublet transition, since the 0-0 bands appear to be the most intense, a result noted previously for crystalline compounds⁶ but not for glassy solutions.

Interesting comparisons of β -diketone Cr(III) complexes with $\text{Cr}(\text{en})_3^{3+}$ and $\text{Cr}(\text{tn})_3^{3+}$ can be made, since the former are also tris chelates but have low-energy, empty π orbitals, which can delocalize the chromium t_{2g} electrons. The absorption and emission spectra of these complexes have been investigated at 4 and 77°K for pure crystals and for solid solutions (diluted into $\text{Al}(\text{aca})_3$).^{72,73} Again the symmetry allowed 0-0 transitions are the most intense, and considerable vibronic structure appears especially in polarized absorption spectra. The emission spectra are not polarized and are not mirror images of the absorptions, demonstrating that in this instance the electronic transition does indeed alter the bonding and geometry of the molecule. The integrated intensity of the 0-0 band of $\text{Cr}(\text{aca})_3$ does not vary between 4 and 77°K, which is further indication that the transition is not vibronic (vibronic intensities depend on a Boltzmann distribution of vibrational levels, which is itself temperature dependent). Evidence has been presented for a 56-cm^{-1} splitting of the 2E state of $\text{Cr}(\text{aca})_3$ and for Cr-Cr interactions in the solid.⁷³ Halide derivatives of $\text{Cr}(\text{aca})_3$ in the host $\text{Al}(\text{Br-aca})_3$ show broad coupling of the 0-0 band to lattice modes of the solid, which probably results from the nonisomorphism of the host and guest. Finally, the 2T_1 state of $\text{Cr}(\text{aca})_3$ is estimated to be between 14,482 and 14,573 cm^{-1} . It should be split into three components in D_3 symmetry; two of these are tentatively assigned in the low-temperature absorption spectrum.⁷²

The vibrational structure of $\text{Cr}(\text{urea})_6^{3+}$ was mentioned in the previous section.⁶⁰ At this point it is useful to point out two curiosities in the spectra of this ion. In the first place, the 0-0 band of 2E emission and absorption is the most intense, and secondly, the 4T_2 absorption and emission appear to be mirror images. Ideally the complex is centrosymmetric; therefore the 0-0 phosphorescence band should be weak. It may be that the ground-state complex ion with six bulky urea ligands around Cr(III) is actually distorted from "pure" octahedral symmetry such that there is no center of inversion. With regard to the second point we note that the large Stokes' shift of the fluorescence band from the absorption band requires that there be an appreciable change of equilibrium internuclear distances in the upper state. However, lacking resolution of the two bands, no conclusions can be made concerning the force constants or angular nuclear positions in the 4T_2 state.

Another "centrosymmetric" complex ion, which has been examined in detail in the pure crystal,⁷⁴ in glasses,⁷⁴ and in solid solutions⁷⁵ ($\text{K}_3[\text{Co}(\text{CN})_6] \cdot \text{Cr}^{3+}$) is $\text{Cr}(\text{CN})_6^{3-}$. There are discrepancies in the two studies of this ion. For example, while fine structure is observed in absorption and emission (2E_g) for both the pure and doped crystals, in ref 74 the spectra are reported as mirror images, and in ref 75 only a 340-cm^{-1} vibration is common to absorption and emission. This difference could be the result of distortions of hexacyanochromium(III) in the hexacyanocobalt(III) lattice, but in ref 75 it is ascribed to an incorrect assignment for the spectrum of the pure compound. In fact, in the first study (pure compound) the 0-0 absorption band was assigned to the most intense peak ($12,470\text{ cm}^{-1}$), quite unlikely for a centrosymmetric ion, and

(72) P. X. Armendarez and L. S. Forster, *J. Chem. Phys.*, **40**, 273 (1964).

(73) M. Courtois and L. S. Forster, *J. Mol. Spectrosc.*, **18**, 396 (1965).

(74) H. L. Schlaefer, H. Gausmann, H. F. Wasgestian, and H. U. Zander, *Z. Phys. Chem. (Frankfurt am Main)*, **51**, 274 (1966).

(75) R. A. Condrate and L. S. Forster, *J. Chem. Phys.*, **48**, 1514 (1968).

(71) G. B. Porter and H. L. Schlaefer, *Z. Phys. Chem. (Frankfurt am Main)*, **38**, 227 (1963).

was reassigned in the latter study (12,380 cm^{-1}). There are bands in emission to the blue of the origin (0-0), most of which disappear upon cooling to very low temperature; these are probably "hot" bands.

The 2E_g state of $\text{Cr}(\text{CN})_6^{3-}$ is split by 49 cm^{-1} in the doped crystal indicating distortion from octahedral symmetry but retention of the inversion center (weak 0-0 band). The 0-0 band is assigned to a magnetic dipole transition. There are no apparent Cr-Cr interactions in $\text{Cr}(\text{CN})_6^{3-}$ as opposed to $\text{Cr}(\text{aca})_3$, since increases in $\text{Cr}(\text{CN})_6^{3-}$ concentration in $\text{K}_3[\text{Co}(\text{CN})_6]$ have no effect⁷⁵ on the splittings of 2E_g . The 2T_1 state is again located in absorption and excitation spectra (15,220-15,620 cm^{-1}).

A series of oxygen coordinated molecular complexes with organic ligands, other than derivatives of acetylacetonone, has been investigated.^{76,77} The ligands of the complexes are dma, dmf, acetamide, imidazolidone, and the chelate biuret. With the exception of the chelate and of dma, which fluoresces weakly, the complexes are octahedral and are similar to the hexaurea complex. A major difference, though, is that here the 0-0 band is quite weak in phosphorescence and absorption, and there is more intense fine structure. In contrast, the D_3 symmetry chelate compound (biuret) shows an intense 0-0 band in absorption and emission of the 2E state. It is difficult to rationalize why the dmf, acetamide, and imidazolidone complexes should be centrosymmetric if the urea is not.

Another hexaoxygen coordinated complex ion is the $\text{Cr}(\text{ox})_3^{3-}$ ion. The vibrational structures of solid $\text{NaMg}[\text{Al}(\text{ox})_3] \cdot 9\text{H}_2\text{O} \cdot \text{Cr}^{3+}$ and pure $\text{NaMg}[\text{Cr}(\text{ox})_3] \cdot 9\text{H}_2\text{O}$ have been studied in detail,^{78,79} and the $\text{Cr}(\text{ox})_3^{3-}$ chromophore has also been studied in glassy solution.⁸⁰ In all cases the 0-0 band of the ${}^2E \rightarrow {}^4A_2$ transition is the most intense, although in the crystal the 2E state is split about 20 cm^{-1} as a result of reduced symmetry. The vibrational progressions⁷⁹ are the same for emission from either of the two components of 2E and are quite similar to the fine structure observed in the absorption to 2E . Again it appears that the saturated $\text{C}_2\text{O}_4^{2-}$ ligand, having little interaction with the t_{2g} $\text{Cr}(\text{III})$ electrons, does not show distortion on excitation to the 2E state. (It has been stated that the $\text{Cr}(\text{ox})_3^{3-}$ absorption and emission spectra are not mirror images;⁷⁸ however, the table from ref 79, p 4217, shows a very close correspondence between most vibrations at 80°K.)

The low-temperature polarized spectra (absorption and emission) show a further splitting of the two components of the 2E state,⁷⁹ the one of higher energy by 2.4 cm^{-1} , and the other of lower energy by 3.1 cm^{-1} . This splitting is probably due to Cr-Cr interactions. The polarized spectra have also been used to locate the 2T_2 and the (tentative) 2T_1 states in $\text{Cr}(\text{ox})_3^{3-}$.

Very little is known about the vibrational structure of the 4T_2 state of $\text{Cr}(\text{III})$ because in general the absorption spectra are very broad and unresolved. It is quite certain that the state is distorted from the 4A_2 state because of the large Stokes' shifts observed between absorption and fluorescence.^{80,81}

Also, in the few reports of fluorescence of $\text{Cr}(\text{III})$ complexes there has been no report of fine structure until that recently observed for some sulfur coordinated ligands.⁸² In an extension of this work, to include some analogous selenium coordinated ligands, more pronounced apparent structure has been observed.⁸³ Naturally, structure in emission is associated with the ground state of the molecule, but it will involve rather high vibrational levels of the 4A_2 state. These levels are not observed in infrared spectroscopy because of vibrational selection rules and the existing Boltzmann distribution.

The measurement of emission quantum yields is a difficult task because of the necessity of determining exactly the intensities of absorbed and emitted light. In principle this is not a problem,²⁶ but in practice it can be extremely difficult because of the need for reproducibility in sample and light conditions. Lifetimes, on the other hand, are easily measured if the appropriate instrumentation (*i.e.*, flash or stroboscopic apparatus) is available. This contrast might explain why only one research group (that of Professor L. S. Forster at the University of Arizona) has published results of quantum yield determinations for transition metal complexes, while a number of different groups have reported lifetime data.

The utility of quantum yield (ϕ) and lifetime (τ) determinations has been the explanation of the significance of the different probability constants, k_2 - k_6 , in Figure 2, and therefore the mechanisms of energy storage and transfer within the chromium complex ion or molecule. Two general studies have been published^{86,84} and more specific results are available for $\text{Cr}(\text{aca})_3$ complexes in the pure state and in the $\text{Al}(\text{aca})_3$ host.⁸⁵ The temperature dependencies of ϕ and τ also have been discussed for $\text{Cr}(\text{OH})_2^{3+}$, $\text{Cr}(\text{OD})_2^{3+}$, and $\text{Cr}(\text{CN})_6^{3+}$ in different crystalline hosts.⁸⁶⁻⁸⁸

Equation 11 gives the expression for the phosphorescence lifetime. At very low temperatures the value of τ is usually temperature insensitive and is called the inherent lifetime, $\tau^0 = (k_5^0 + k_6^0)^{-1}$, where k_5^0 and k_6^0 are the temperature-independent probabilities for radiative and nonradiative transition from 2E to 4A_2 . For ruby ($\text{Al}_2\text{O}_3 \cdot \text{Cr}^{3+}$) $k_6^0 \simeq 0$, and $\tau^0 = (k_5^0)^{-1} \simeq 4$ msec. For $\text{Cr}(\text{aca})_3$, $\tau^0 \simeq 2$ msec, and it is proposed that k_5^0 in this complex probably has approximately the same numerical value as in ruby⁸⁶ (*i.e.*, the radiative rate constant for phosphorescence is insensitive to the environment of Cr^{3+}). If this is true k_5 should be similar in all the acetylacetonone derivative complexes, and thus the variations in τ represent variations in k_6 or the nonradiative transition probability from 2E to 4A_2 . From the tables in ref 64 and 66 it can be seen that the values of τ or k_6 follow, roughly, changes in π bonding in the complexes. However, the relationship is in the opposite direction for complexes of other ligands,⁸⁴ and no uniform correlation of the nonradiative transition probability to molecular structure has yet been found.

(76) K. K. Chatterjee, G. B. Porter, and D. L. Webb, private communication.

(77) K. K. Chatterjee and G. B. Porter, *Inorg. Chem.*, **5**, 860 (1966).

(78) R. A. Condrate and L. S. Forster, *J. Mol. Spectrosc.*, **24**, 490 (1967).

(79) O. S. Mortensen, *J. Chem. Phys.*, **47**, 4215 (1967).

(80) H. L. Schlaefer, *J. Phys. Chem.*, **69**, 2201 (1965).

(81) A. W. Adamson, *ibid.*, **71**, 798 (1967).

(82) P. Cancellieri, E. Cervone, C. Furlani, and G. Sartori, *Z. Phys. Chem. (Frankfurt am Main)*, **62**, 35 (1968).

(83) E. Cervone and P. D. Fleischauer, 157th National Meeting of the American Chemical Society, Minneapolis, Minn., April 13-18, 1969.

(84) (a) K. K. Chatterjee and L. S. Forster, *Spectrochim. Acta*, **20**, 1603 (1964); (b) K. K. Chatterjee and L. S. Forster, *ibid.*, **21**, 213 (1965).

(85) W. Targos and L. S. Forster, *J. Chem. Phys.*, **44**, 4342 (1966).

(86) G. J. Goldsmith, F. V. Shallcross, and D. S. McClure, *J. Mol. Spectrosc.*, **16**, 296 (1965).

(87) F. Diomedei Camassei, R. A. Condrate, and L. S. Forster, Proceedings of the XIth International Conference on Coordination Chemistry, Haifa, Israel, 1968.

(88) F. Diomedei Camassei and L. S. Forster, *J. Chem. Phys.*, **50**, 2603 (1969).

Equation 9 gives the expression for ϕ_p . Dividing ϕ_p by τ_p one obtains

$$\phi_p/\tau_p = k_4 k_5 / (k_2 + k_3 + k_4) \quad (12)$$

By making certain assumptions it is possible to estimate the contribution of different effects on the probability constants. For example, because there is no fluorescence observed for any of the aca complexes⁸⁶ it is assumed that $k_2 \ll (k_3 + k_4)$. If $k_3 \simeq k_4$ then $\phi_p/\tau_p \simeq k_5$ and the variations observed in ϕ/τ would simply be due to changes in the radiative transition probability, in contradistinction to the earlier assumption that k_5 was constant. It may be that k_3 and k_4 are approximately equal. Internal conversion (k_3) is spin-allowed, while intersystem crossing (k_4) is spin-forbidden, but since these are radiationless transitions, the more important factor may be the energy gaps. In fact, values of ϕ/τ for ligands⁸⁴ other than aca approximate k_5 values calculated from ligand field theory. From such behavior it is suggested that the condition $k_3 \simeq k_4$ is valid, and thus internal conversion from 4T_2 to 4A_2 is just as probable as intersystem crossing from 4T_2 to 2E . (Keep in mind that results from very different types of complexes have been compared.)

Measurements of the variations of ϕ_p and τ_p with temperature indicate some slightly different conclusions for the Cr-(aca)₃ complexes.⁸⁵ Both ϕ_p and τ_p show at least two temperature-dependent processes, but ϕ_p/τ_p does not vary with change in temperature. Radiative transition probabilities (k_2 and k_3) of allowed transitions are not temperature dependent,⁸⁹ so the constancy of ϕ_p/τ_p means either that (a) $k_2 + k_3 \ll k_4$, or that (b) $k_3 + k_4 = k_3^0 + k_4^0$. The authors⁸⁵ prefer alternative b which means that only k_5 varies with temperature in these complexes, a questionable result until it is realized that k_5 includes k_{-4} , which, by definition, has to be temperature dependent unless the 4T_2 state is lower in energy than 2E .⁹⁰

Additional evidence that k_{-4} represents an important activated path for dissipation of excitation energy is provided in a study⁹¹ of the temperature dependence of the relative phosphorescence intensities of the complexes in Table III. The changes of intensity fit the empirical Arrhenius expression, $I = c/(A + e^{-\epsilon/T})$, where $\epsilon = E_a R^{-1}$. From the fact that only one temperature-dependent process is observed it is argued that (a) the activated process involves k_{-4} or (b) $k_{-4} = 0$ and either k_3 or k_5 is the only temperature-dependent path. Further, by comparing the trend in E_a with that of ΔE (see Figure 4, Table IV, and section B.3), it is concluded that alternative a is correct and E_a is related to the energy separation between the ground vibrational level of 2E and the crossover point of the potential energy surfaces for 2E and 4T_2 .

Proof that thermal population of the 4T_2 state is an important temperature-dependent process can be found in studies of ionic⁹² and molecular^{70,76,87,88} complexes of Cr(III). In all of these cases fluorescence ${}^4T_2 \rightarrow {}^4A_2$ is observed to appear and/or increase at the expense of phosphorescence ${}^2E \rightarrow {}^4A_2$ as the temperature is raised. The fluorescence activation

Table III
Activation Energies *vs.* ΔE^a for Some Cr(III) Complexes (after Ref 91)

Compound	Absorption max (4T_2), kK	Emission max (2E), kK	ΔE , kK	E_a , kK
Cr(CN) ₆ ³⁻	26.7	12.43	14.27	3.92
Cr(NCS) ₆ ³⁻	17.7	12.85	4.85	1.19
<i>cis</i> -Cr(en) ₂ Cl ₂ ⁺	18.8	14.42	4.38	0.805
Cr(NH ₂ CH ₃) ₃ Cl ₂ ⁺	19.0	14.70	4.30	0.665
<i>cis</i> -Cr(en) ₂ Br ₂ ⁺	18.0	14.40	3.60	0.665

^a See Figure 4 and Table IV for definition and trends in ΔE .

energy varies for different complexes (for ruby there is no fluorescence until $T \geq 300^\circ\text{K}$; but for emerald, Cr(urea)₆³⁺, and others, where E_a is much smaller, fluorescence is seen at $T \geq 80^\circ\text{K}$). The molecular complex Cr(OD₂)₆³⁺ in two different hosts (*i.e.*, GASD and AlCl₃·6D₂O) shows an increase of fluorescence and a decrease of phosphorescence as the temperature is raised from ~ 20 to 300°K . The effect is most pronounced in the AlCl₃ host.⁸⁸

In the most recent study of molecular complexes in both solid and glass states it is reported that a temperature dependence is observed for vibronic transitions as well as for radiationless processes.^{6,87,88} That is to say, k_5 need not be constant with temperature. It may vary by as much as a factor of 2.5 from 80 to 300°K as in⁸⁸ K₃[Co(CN)₆]:Cr³⁺. The net effects on ϕ/τ produced by the temperature variation of k_5 , however, are in the direction opposite to the effects produced by variations in k_3 , k_{-4} , and k_6 . All four constants increase with increasing temperature, but k_5 is the only one that can make ϕ_p/τ_p increase rather than decrease (see eq 12). In fact ϕ_p/τ_p does increase from 20 to 300°K for Cr(CN)₆³⁻ and Cr(OD₂)₆³⁺, both of which have essentially vibronic 2E transitions, but it remains constant for Cr(aca)₃ and Cr(ox)₃³⁻, which have symmetry allowed 2E transitions.

4. Theoretical Implications

In previous sections we have discussed vibrational fine structure, radiationless transitions, and other subjects which relate to theory, but in this section we treat separately the questions of fluorescence *vs.* phosphorescence in a given complex, nephelauxetic effects, and medium effects. Among the chromium complexes with oxygen coordinated ligands one finds some that phosphoresce only, others that show both types of emission, and still others that fluoresce only.⁷⁶ These differences were attributed to different values of $10Dq$ as measured from the maximum of the ${}^4T_2 \leftarrow {}^4A_2$ absorption band. Complexes with the largest $10Dq$ values (*i.e.*, those in which the 4T_2 state was higher in energy than 2E) phosphoresced while those with small $10Dq$ fluoresced. Logically, in Cr(III), emission originates from the lowest energy state, be it doublet or quartet, and from both states when their energies are approximately equal. One exception to this prediction, however, is Cr(imid)₆³⁺ which has ligand field parameters identical with Cr(urea)₆³⁺ but which exhibits only phosphorescence.⁷⁷

A more comprehensive theory to explain phosphorescence *vs.* fluorescence was proposed after a study of some halide complexes⁶² and in particular some mixed aquafluoro complexes.⁶¹ The quantity critical to this theory is shown in Figure 4. Because of the difficulty of locating the origin of the 4T_2

(89) M. Gouterman, *Chem. Rev.*, **65**, 413 (1965).

(90) Inclusion of k_{-4} in the kinetic scheme (*i.e.*, eq 12) results in quite complicated expressions which are treated in ref 87, 88, and 91. The expressions for ϕ_p in ref 88 and 91 are actually equivalent and are obtained by different procedures for factoring the expression for 2E concentration.

(91) H. L. Schlaefer, H. Gausmann, and H. Witzke, *Z. Phys. Chem.* (Frankfurt am Main), **56**, 55 (1967).

(92) P. Kisliuk and C. A. Moore, *Phys. Rev.*, **160**, 307 (1967).

absorption band an easily measurable experimental quantity ΔE was devised which gives a good *approximation* of the relative positions of the minima of the 4T_2 and 2E states. ΔE is the energy difference between the *maxima* of the ${}^4T_2 \leftarrow {}^4A_2$ and ${}^2E \leftarrow {}^4A_2$ absorption bands. Originally proposed for octahedral complexes the theory predicts only phosphorescence if $\Delta E \geq 2.4$ kK, both fluorescence and phosphorescence if ΔE is between 1.7 and 2.4 kK, and only fluorescence if $\Delta E = 1.7$ kK. When extended to nonoctahedral Cr(III) complexes with sulfur and selenium ligands, the theory holds, but with the phosphorescence-only limit at 2.8 kK.^{82,83} In general ΔE follows $10Dq$ since the energy of 2E is quite constant, but Table IV shows that at least three exceptions do exist (at Cr(antip)₆³⁺, Cr(xant)₃ and Cr(CH₃)₆³⁻).

It is reasonable that the type of emission should depend on the nature of the lowest excited state, but it does seem strange that ΔE should be a good variable for estimating the lowest state. The value of ΔE depends not only on the position of the minimum of the 4T_2 state relative to 2E but also on the shape of the potential energy surface for 4T_2 . The fact that ΔE does predict the luminescence behavior of most complexes means that the 4T_2 potential surfaces are indeed the same general shape for all of these complexes, a result quite extraordinary considering the vast differences in ligand structure and bonding.

One further point is that the 2E lifetimes in complexes with intermediate values of ΔE (*i.e.*, those which also fluoresce) are short, but not as short as the inherent 4T_2 lifetimes.⁶¹ The lifetimes of *ionic* complexes⁹² in the temperature ranges where fluorescence and phosphorescence occur simultaneously are also shortened considerably, and $\tau_f = \tau_p$. This means that equilibration between 2E and 4T_2 is extremely rapid at sufficiently high values of kT and, consequently, that most fluorescence in chromium(III) compounds is probably "delayed" fluorescence, with the possible exception of CrF₆³⁻ and CrCl₆³⁻, where the 4T_2 state is necessarily lower than 2E (ΔE is negative). This behavior is analogous to E-type delayed fluorescence in organic molecules.

The nephelauxetic effect⁹³ refers to the delocalization of metal "d" electrons by the ligands and is monitored by changes in the interelectronic repulsion parameters B and C . The relative energies of the first two spin-allowed and the first spin-forbidden transitions can be expressed as follows.

$$\begin{aligned} E({}^4T_2 - {}^4A_2) &= \Delta \\ E({}^4T_1(F) - {}^4A_2) &= \Delta + 12B \\ E({}^2E - {}^4A_2) &= 9B + 3C \end{aligned}$$

(To account for configuration interaction among excited states an additional term, $-50B^2/\Delta$, must be included in the doublet-state energy expression. This term has been included in the calculations for Table V.)

The quantity B can be calculated from the difference between the two spin-allowed transition energies and with this, using the doublet energy, C can be determined. Often the energy of the ${}^4T_1 \leftarrow {}^4A_2$ transition cannot be obtained because of overlap with more intense CT or ligand bands, so B must be calculated directly from the doublet energy, assuming $C = 4B$. In complexes where both quartet bands are resolved the application of both of these methods does not always yield

the same value for B , and therefore two B 's have been defined, B_{85} referring to the spin-allowed transitions which involve both t_{2g} and e_g orbitals, and B_{55} for the doublet energy which involves only t_{2g} electrons.⁹⁴ B_{55} is a direct measure of the delocalization of metal d electrons by π bonding since it involves only t_{2g} orbitals, while B_{85} combines effects of σ and π bonding. The two B values represent the respective interelectronic repulsion energies in a specific complex. If a given B is compared to the corresponding constant from the free gaseous ion, the nephelauxetic ratio $\beta = B_{\text{complex}}/B_{\text{free ion}}$ is obtained. These β quantities are always less than one because the ligands always partially delocalize the metal electrons and thus reduce the repulsion between electrons.

Because of the possibility that both B and C can depend on the ligands, a phenomenological parameter was defined in early work.⁶⁴

$$\gamma = \bar{\nu}({}^2E \rightarrow {}^4A_2)/\bar{\nu}({}^2E \rightarrow {}^4A_2)_{\pi=0}$$

The doublet energy when $\pi = 0$ was assigned to the energy of the maximum of phosphorescence in the Cr(en)₃³⁺ complex for which there are no available empty ligand π orbitals. The values of γ calculated are given in ref 64. B_{55} values will follow the same trends as γ and will help relate the π bonding in the aca complexes to other ligands. There is little change in γ when the ligands have no empty π orbitals, but it is reduced considerably for those ligands which are capable of metal to ligand π bonding, with the exception of dipyrindine. For Cr(dipy)₃³⁺, $\gamma = 0.913$, indicating little π bonding, a situation in complete contrast to another d³ complex,⁹⁵ V(dipy)₃²⁺.

In general it is found that when values of β_{85} and β_{55} are calculated for d³ complexes, β_{85} is less than β_{55} , or that σ bonding delocalizes the metal d electrons more than π bonding. In the case⁹⁵ of [V(dipy)₃]I₃, however, β_{85} was found to be 1.47 while β_{55} was 0.84. The greater π delocalization ($\beta_{55} < \beta_{85}$) does not represent so much a decrease in β_{55} as an increase in β_{85} . In fact, the β_{85} value is an extraordinary one and is discussed in light of the theory of the nephelauxetic effect.⁹⁵

The very noticeable nephelauxetic effect of sulfur and selenium coordinating ligands has been noted from their absorption spectra.⁹⁶ More accurate calculations of β_{55} can be made from the emission spectra when phosphorescence is observed.^{82,83} Unfortunately, because of the generally small values of $10Dq$ and ΔE , most sulfur coordinated complexes exhibit fluorescence rather than phosphorescence. Judging from the calculations of β_{55} that are available the small ΔE values and their differences appear to result from changes in $10Dq$ rather than β_{55} , if only S or Se bonded ligands are considered (see Table V). Both β values are relatively constant over the series of S bonded complexes (β_{85} varies by 9% and β_{55} by 2%, while Dq varies by 22%) and are quite small. In general, values for Se bonded ligands are smaller than for the analogous S bonded ligands. This is apparent most in β_{85} and is explained by the fact that the large Se atom cannot form efficient π bonds, but is very polarizable and can delocalize σ electrons.

Most of the studies of Cr(III) complexes which treat the assessment of medium effects deal with the vibrational structure in the absorption and emission bands (see section B.2). There is one study, published recently, which treats the effects

(94) C. K. Jørgensen, *Advan. Chem. Phys.*, **5**, 67 (1963).

(95) G. Sartori, E. Cervone, and P. Cancellieri, *Atti Accad. Naz. Lincei, Rend., Classe Sci. Fis., Mat. Nat.*, **35**, 226 (1963).

(96) C. K. Jørgensen, *Mol. Phys.*, **5**, 485 (1962).

(93) C. E. Schaeffer and C. K. Jørgensen, *J. Inorg. Nucl. Chem.*, **8**, 143 (1959).

of changing the anion in the complex $[\text{Cr}(\text{urea})_6]\text{X}_3$ ($\text{X} = \text{Cl}^-$, I^- , ClO_4^- , etc.).⁹⁷ Counterion effects are well known in the absorption and emission of platinum complexes (see section VIII.B.) and in their photochemistries.⁹⁸ For platinum and heavier elements the effects of ions in the second coordination sphere would be expected to be greater than for first row elements, because the 5d orbitals probably extend beyond the first group of ligands (inner coordination sphere). In Cr(III) this is not as likely, especially in the bulky complex $\text{Cr}(\text{urea})_6^{3+}$. On the other hand, the anion might have large effects on the distortions in $\text{Cr}(\text{urea})_6^{3+}$ mentioned above (see section B.2). In some cases ($\text{Cr}(\text{en})_3^{3+}$) a heavy anion such as Br^- or I^- enhances emission and may be responsible for room-temperature phosphorescence.⁹³

Table IV
Dependence of Emission of Cr(III) on
Quartet-Doublet Separation (after Ref 61 and 62)

Compound	${}^4T_2^a$	${}^2E^a$	ΔE^b	Type of emission ^c
CrBr ₃	12.95			F
CrCl ₃	13.70			F
CrCl ₆ ³⁻	13.06	14.48	-1.42	F
CrF ₆ ³⁻	14.90	15.70	-0.80	F
K ₂ [CrF ₆ OH ₂]	15.85	15.13	0.72	F
[CrF ₆ (OH ₂) ₃ ·H ₂ O]	16.34	15.04	1.30	F
[CrF ₆ (OH ₂) ₃]	16.42	14.93	1.49	F
Cr(antip) ₆ ³⁺	15.72	14.03	1.77	B
Cr(urea) ₆ ³⁺	16.15	14.35	1.80	B
[Cr(OH ₂) ₆]F ₃	17.27	15.15	2.12	B
Cr(xant) ₃	15.60		2.88	P
Cr(ox) ₃ ³⁻	17.50	14.35	3.15	P
Cr(NCS) ₆ ³⁻	17.70	13.01	4.69	P
Cr(aca) ₃	18.40	12.95	5.35	P
Cr(NH ₃) ₆ ³⁺	21.55	15.30	6.25	P
Cr(tn) ₃ ³⁺	21.59	15.03	6.56	P
Cr(en) ₃ ³⁺	21.85	14.95	6.90	P
Cr(CH ₃) ₆ ³⁻	20.80	13.42	7.38	P
Cr(dipy) ₃ ³⁺	22.0	13.75	9.25	P
Cr(C ₆ H ₅) ₆ ³⁻	22.2	12.6	9.6	P
Cr(o-phen) ₃ ³⁺	23.8	13.7	10.10	P
Cr(CN) ₆ ³⁻	26.7	12.47	14.23	P

^a Frequencies (kK) of maxima of absorption bands for indicated states. ^b See Figure 4, energy difference between tabulated maxima. ^c F = fluorescence only; B = both phosphorescence and fluorescence; P = phosphorescence only.

5. Energy-Transfer Studies

Although this area of investigation is limited at present, we consider it important enough to be treated separately primarily because of some very recent results. Intramolecular energy transfer (*i.e.*, internal conversion, transfer from ligand states to metal states, etc.) has been recognized since early experiments, in which ligand bands were irradiated and chromium phosphorescence was observed.⁹⁹ An illustrative example of the effects of metal ions on ligand transitions (emis-

Table V
Nephelauxetic Ratios for Cr(III) Sulfur and
Selenium Bonded Complexes

Compound	$10Dq$, kK	ΔE , kK	β_{55}	β_{35}	Type of emission ^d
Cr(xant) ₃	16.2	3.3	0.776	0.434	P
Cr(dtc) ₃	15.63	2.83	0.741	0.494	B
Cr(Sexant) ₃ ^a	15.25	2.55	0.737	0.344	P (B)
Cr(dsc) ₃	14.93	2.43	0.744	0.375	B
Cr(tgl)(OH ₂) ₅ ²⁺ ^b	17.5	2.0	0.945	0.682	F
Cr(tu) ₃ Cl ₃	14.4	1.7	0.776	0.521	F
Cr(dtox) ₃ ^b	17.15	1.65	0.951	0.478	F
Cr(dtp) ₃	14.45	1.3	0.806	0.478	F
Cr(dsp) ₃ ^c	13.93	0.81-1.27	0.757	0.348	F
Cr(dtpi) ₃	13.8	0.65	0.811	0.434	F

^a From measurements of glassy solution. Solid shows some fluorescence. ^b Ligands probably coordinated through oxygen atoms. ^c Only solid sample emits. ^d Designations same as Table IV.

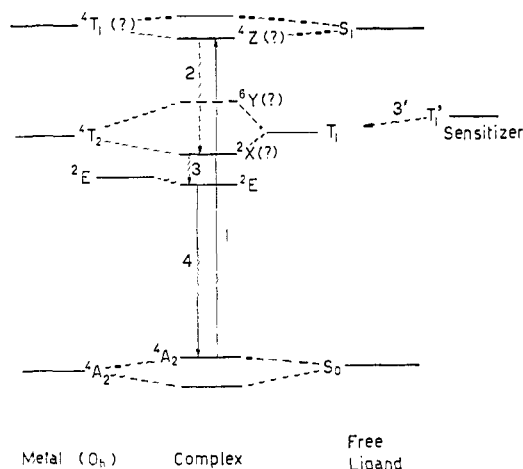

Figure 5. Approximate representation of the mixing of the energy levels of a d^3 metal and an organic ligand. S_0 and S_1 are ligand singlet states. T_1 and T_1' are ligand and sensitizer triplet states. (1) Absorption in an essentially ligand band. (2 and 3) Radiationless decay to the 2E state. (4) Phosphorescence from the metal level.

sion) is a study of the luminescence of some metal oxinates.¹⁰⁰ For all the metal ions (transition, nontransition) coordinated to 8-hydroxyquinoline (oxine) and its derivatives—except Cr(III)—the normal luminescence of the ligands is observed. With $\text{Cr}(\text{hq})_3$ and $\text{Cr}(2\text{-CH}_3\text{-hq})_3$ irradiation in the ligand bands yields Cr(III) phosphorescence, while with $\text{Cr}(5,7\text{-diBr-hq})_3$ ligand fluorescence is observed. The presence or absence of energy transfer (ligand to chromium) depends on the relative positioning of the energy states of the ligand and metal (see Figure 5). Mixing of metal states with those of the ligand under favorable symmetry and spin conditions is probable because of the geometric proximity of the two moieties.

In contrast, intermolecular energy transfer between organic molecules in the triplet state (T_1' in Figure 5) and Cr(III) is much less probable because of spin state differences and dis-

(97) (a) K. H. Hansen and G. Vierke, *Theor. Chim. Acta*, **6**, 272 (1966); (b) G. Vierke and K. H. Hansen, *Z. Phys. Chem.* (Frankfurt am Main), **59**, 109 (1968).

(98) P. D. Fleischauer, Ph.D. Dissertation, University of Southern California, 1968.

(99) J. L. Laver and P. W. Smith, *Chem. Commun.*, 769 (1968).

(100) D. C. Bhatnagar and L. S. Forster, *Spectrochim. Acta*, **21**, 1803 (1965).

tance restrictions (the Cr(III) is well shielded by its coordination sphere). As evidence of improbable interactions with Cr(III) it is found that oxygen has little effect on the intensity of phosphorescence at any temperature. Initial evidence that energy transfer might be possible was provided in a study¹⁰¹ of the quenching of triplet states of organic donor molecules in solution by Cr(aca)₃. The diffusion controlled quenching constant was attributed to a paramagnetic effect of Cr(III) rather than actual intermolecular energy transfer. Organic molecule triplet state to chromium doublet transfer is unfavorable because of the net change in spin multiplicity (*i.e.*, $T_1 + {}^4A_2 \rightarrow S_0 + {}^2E$; $\Delta S = -2$).

Most recently, however, elegant work has been described in which photosensitized phosphorescence of a series of Cr(III) complexes has been observed.¹⁰² Stern-Volmer plots²⁶ of ϕ_D and τ_D vs. complex concentration were made, and it was found that as donor emission was quenched in fluid solution acceptor phosphorescence appeared and increased in intensity. Upon freezing the solution, the chromium emission disappeared and the donor emission reappeared. Although oxygen does not affect Cr(III) phosphorescence when the Cr(III) is directly irradiated, it does quench both the 2E phosphorescence and the donor emission when the organic donor is irradiated. When observed with a flash apparatus the sensitized Cr(III) emission exhibits an induction period which is slightly less than the lifetime of the donor triplet. All of these observations suggest very definitely that energy, absorbed by the organic molecule which then undergoes intersystem crossing, is transferred to the quartet or doublet state of Cr(III). The nature of the energy spacings of complexes such as Cr(CN)₆³⁻, Cr(NCS)₆³⁻, and Cr(en)₃³⁺ excludes transfer to the Cr(III) *via* a ligand triplet level.

Another study which can be interpreted to show intermolecular energy transfer is a recent one⁷⁰ on the double salt [Cr(urea)₆][Cr(CN)₆] \cdot 3H₂O. In this case the two chromium chromophores can be treated independently because the spectrum of the double salt is exactly the sum of the spectra of the individual components. The cation absorbs all of the 580-m μ (17.5 kK) and most of the 436-m μ (22.9 kK) exciting light, but irradiation at either wavelength results in emission of the anion. While 580-m μ light also produces some phosphorescence of the cation, 436-m μ light gives rise to anion phosphorescence only. The intensity of the latter is also some twenty times that of pure K₃[Cr(CN)₆]. Evidently intersystem crossing from the ${}^4T_{1g}(F)$ state of Cr(urea)₆³⁺ to ${}^2T_{2g}$ of Cr(urea)₆³⁺ or of Cr(CN)₆³⁻ is more efficient than internal conversion ${}^4T_{1g} \rightarrow {}^4T_{2g}$ (cation) (see Figure 6), but the internal conversion ${}^4T_{2g} \rightarrow {}^4A_{2g}$ of Cr(CN)₆³⁻ must significantly reduce the emission ${}^2E_g \rightarrow {}^4A_{2g}$ in pure K₃[Cr(CN)₆].

Finally, a number of intermolecular energy transfers from Cr(III) to Nd(III) (*f³*) have been reported.¹⁰³ Cr(III) and Nd(III) in aluminates of lanthanum and yttrium and in glasses have been studied. The different reports vary in whether the lifetimes of Cr(III) and Nd(III) emissions are affected by each

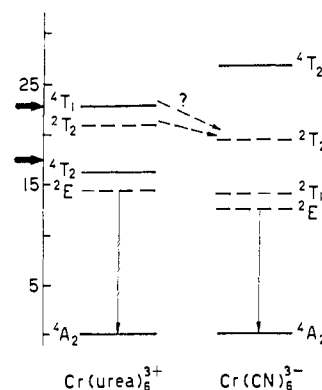

Figure 6. Approximation of the energy levels in [Cr(urea)₆][Cr(CN)₆] \cdot 3H₂O. Heavy arrows on left indicate frequencies of exciting light. Vertical arrows show phosphorescence of each chromophore. The excited quartet levels are drawn at the energies of the absorption band maxima but the 0-0 transitions are as much as 2 kK lower (after ref 70).

other's presence, and thus as to whether transfer is from the quartet or doublet state of chromium to the neodymium quartet or doublet or to both. One example of transfer from Eu³⁺ to Cr³⁺ is reported.¹⁰⁴

C. OTHER d³ METALS

Other than the reports discussed under solid-state considerations (*i.e.*, ionic complexes), the material concerning other d³ metal ions is sparse. [V(dipy)₃]I₂ has been mentioned.⁹⁵ Along with Cr(dipy)₃³⁺ it is an interesting dipyrindine complex, because it too shows distinct metal ion phosphorescence. Dipyrindine and *o*-phenanthroline complexes of heavier metals (see sections VI.C and VIII.B.2) show emission which is probably charge-transfer luminescence and which depends on the lowest energy excited state of the complex as a whole.

K₂[MnCl₆] is the only other first-row d³ metal ion molecular complex which has been found to emit.⁹⁵ It too produces 2E_g phosphorescence (12.19 kK) when excited in the spin-allowed absorption bands.

Of 15 Mo(III) complexes investigated, three were found to luminesce.¹⁰⁵ The emission was phosphorescence and the maxima were at longer wavelengths than those normally seen for Cr(III). While 10Dq is larger for the second-row elements than for the first row elements, it is felt that *B* and β are probably smaller, causing the 2E_g state to decrease in energy with respect to ${}^4A_{2g}$. Emission of Mo³⁺ in a boro-alumino-phosphate glass also has been observed¹⁰⁶ near 1 μ (10 kK). The results of the emission of these compounds are included in Table VI with the chromium complexes.

V. Compounds of d⁵ Metal Ions

The results of studies of the d⁵ electronic structure are confined to two first-row transition metals, Mn(II) and Fe(III). The configuration is unique because with but one or two exceptions (Fe(CN)₆³⁻, Mn(CN)₆⁴⁻) it is high spin, resulting in an exactly half-filled d orbital system. The ordering of spec-

(101) A. J. Fry, R. S. H. Liu, and G. S. Hammond, *J. Amer. Chem. Soc.*, **88**, 4781 (1966).

(102) D. J. Binet, E. L. Goldberg, and L. S. Forster, *J. Phys. Chem.*, **72**, 3017 (1968).

(103) (a) J. Murphy, R. C. Ohlmann, and R. Mazelsky, *Phys. Rev. Lett.*, **13**, 135 (1964); (b) Z. J. Kiss and R. C. Duncan, *Appl. Phys. Lett.*, **5**, 200 (1964); (c) G. O. Karapetyan, V. P. Kovalyov, and S. G. Lunter, *Opt. Spectrosc.*, **19**, 529 (1965); (d) P. P. Feofilov, V. A. Timofeeva, M. N. Tolstoi, and L. M. Belyaev, *ibid.*, **19**, 451 (1965); (e) R. C. Ohlmann and R. Mazelsky, *Phys. Quantum Electron.*, **1965**, 322 (1966); *Chem. Abstr.*, **67**, 16625 (1967).

(104) G. Blasse and A. Brill, *Phys. Status Solidi*, **20**, 551 (1967).

(105) H. L. Schlaefler, H. Gausmann, and H. Witzke, *J. Mol. Spectrosc.*, **21**, 125 (1966).

(106) A. L. Watson and S. Parke, *Brit. J. Appl. Phys.*, **17**, 963 (1966).

trosopic states obtained from five unpaired d electrons is the same for tetrahedral as for octahedral symmetry of the ligand field even though the relative energies of e and t_2 orbitals are inverted.^{8, 18}

As a result of placing one electron in each d orbital the ground state is a sextet and is totally symmetrical, 6S in the free ion and 6A_1g in an O_h field. This is the maximum possible multiplicity; all transitions in the absorption or emission spectra must therefore be spin forbidden. The energies of the d-d transitions may or may not be functions of $10Dq$, depending on whether the transitions are intra- or interconfigurational, but are always functions of B and C . If the ground-state energy is zero that²⁰ of the first excited state, 4T_1 , is $-10Dq + 10B + 6C$, and therefore decreases in energy as $10Dq$ increases and B and C remain constant (see Figure 7). This interesting circumstance arises with other high spin complexes, but only one example of luminescence has been found (Fe(II) in ZnS; *vide infra*) for d^n where $n \neq 5$. In fact the lowest observed excited state in Mn(II) complexes lies about 20 kK above 6A_1 and does not appear to depend too much on the position of the ligand in the spectrochemical series. The reason for the lack of sensitivity would then be attributed to concurrent changes in the Racah parameters and ligand field strength.

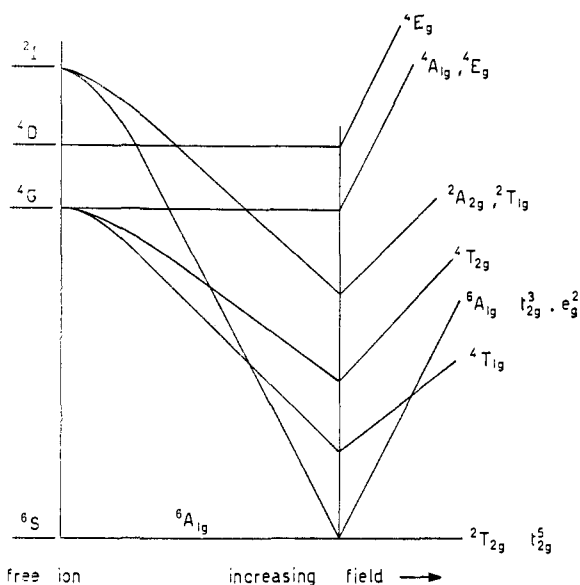

Figure 7. Schematic correlation diagram (lowest levels) for octahedral d^5 metal complexes (after ref 8).

Complexes of Mn(II) can also be divided into those which exist only in the solid state and those that remain intact in solution. The former are definitely ionic in type; the latter also show a tendency to form primarily ionic bonds, and are quite unstable thermodynamically with respect to dissociation in solution. For convenience in finding material we divide the emission studies into the categories of ionic and molecular complexes. A brief section at the end lists some luminescence quenching experiments which have been performed with d^5 metal complexes.

A. IONIC COMPLEXES (SOLID STATE AND GLASSES)

Some of the earliest studies dealing with transition metal

complex emission have been reported for Mn^{2+} in glasses.¹⁰⁷⁻¹⁰⁹ These include silicate, phosphate, and borate glasses and involve attempts to determine the coordination number and symmetry representation of the manganese ion.¹¹⁰ A rule of thumb has been that a green emission signifies tetrahedral coordination while red implies octahedral. Unfortunately the situation is more complicated than this, as evidenced by the fact that Mn^{2+} in known tetrahedral symmetry can give different colored emission. It is true that emission from O_h complexes is found at longer wavelength (lower energy) than for T_d complexes; this is undoubtedly the result of the larger $10Dq$ value in O_h which reduces the transition energy (*vide supra*).

A substantial amount of study of the emission of Mn^{2+} has involved this ion in a zinc sulfide type of environment (e.g., ZnS, ZnSe, CdS, CdSe, etc.). Although we do not intend to discuss the luminescence of crystal phosphors extensively, we would like to include some of the later references which deal specifically with the ligand or crystal field interpretation of such emission. We have found four recent representative references¹¹¹⁻¹¹⁴ concerning this subject for Mn^{2+} . A narrow (500- cm^{-1} half-width) emission with $\bar{\nu}_{max}$ at 17,891 cm^{-1} is observed when ZnS: Mn^{2+} is irradiated in any of four absorption bands. The emission is from the lowest, 4T_1 , excited state to the 6A_1 state, while the absorptions¹¹¹ are to 4T_1 , 4T_2 , 4E , and 4A_1 . The g or u designation has been omitted from these term symbols since the shape and position of the emission indicate T_d symmetry.¹¹⁵ Later studies produced a measured¹¹² Dq of 410 ± 10 cm^{-1} and a calculated lifetime¹¹³ based on T_d symmetry of 1-6 msec. We shall see¹¹⁵ that Dq values in T_d complexes average about 330 ± 50 cm^{-1} and in O_h about 790 ± 10 cm^{-1} . The measured lifetime is 3 msec. Therefore, it seems likely that the emitting Mn^{2+} is in a tetrahedral symmetry site in ZnS.

Some other Mn^{2+} phosphors and some Mn containing minerals also have been studied. More than one decade ago an energy transfer study involving Ce(III) and Mn^{2+} was reported.¹¹⁶ The timing of this article is especially interesting in view of the belated interest in energy-transfer processes, where in recent research Cr^{3+} and Co^{3+} have acted as acceptors (see sections IV.B and VI.C). When the doublet (${}^2D \leftarrow {}^2F$) transition of Ce^{3+} in $CaF_2:Ce:Mn$ is irradiated the ${}^4T_1 \rightarrow {}^6A_1$ phosphorescence of Mn^{2+} is observed.¹¹⁷ The Mn^{2+} at the concentrations used did not absorb appreciably in the region of irradiation. At 90°K the emission has a $\bar{\nu}_{max}$ at 18.20 kK which represents a Stokes' shift of about 1 kK. The emission band is 3.00 kK wide at half-height; the origin of absorption and emission is expected to be at the same frequency. The separa-

(107) S. H. Linwood and W. A. Weyl, *J. Opt. Soc. Amer.*, **32**, 443 (1942).

(108) W. A. Weyl, *J. Appl. Phys.*, **17**, 628 (1946).

(109) J. H. Schulman, *ibid.*, **17**, 902 (1946).

(110)(a) V. V. Osiko, *Dokl. Akad. Nauk SSSR*, **121**, 507 (1968); *Chem. Abstr.*, **53**, 61h (1959); (b) W. A. Weyl and E. C. Marboe, "The Constitution of Glasses," Interscience Publishers, Inc., Vol. 1, New York, N. Y., 1962, p 297.

(111) D. Langer and S. Ibuki, *Phys. Rev.*, **138A**, 809 (1965).

(112) T. Koda, S. Shionoya, M. Ichikawa, and S. Minomerra, *J. Phys. Chem. Solids*, **27**, 1577 (1966).

(113) W. E. Hagston, *Proc. Phys. Soc.*, **92**, 1096 (1967).

(114) S. Asano, N. Yamashita, M. Oishi, and K. Omori, *J. Phys. Soc. Jap.*, **24**, 1302 (1968).

(115) C. Furlani, E. Cervone, and P. Cancellieri, *Atti Accad. Naz. Lincei, Rend., Classe Sci. Fis., Mat. Nat.*, **37**, 446 (1964).

(116) R. J. Ginther, *J. Electrochem. Soc.*, **101**, 249 (1954).

(117) R. Leach, *ibid.*, **105**, 27 (1958).

Table VI
Absorption and Emission Spectral Maxima for d³ Metal Compounds

Compound ^a	Absorption		Emission		Ref
	⁴ T ₂	² E	⁴ T ₂	² E	
Cr(urea) ₆ ³⁺	16.26	14.35	12.55	14.24 ^b	60, 68, 69
Cr(NH ₃) ₆ ³⁺	21.55	15.30		15.12 ^b	62, 68, 84
Cr(OH ₂) ₆ ³⁺	17.4 ^e	(15.0) ^c		14.6 ^d	68
[Cr(OH ₂) ₆]F ₃	17.27	15.15	13.10	14.55	61
[Cr(OH ₂) ₆]Cl ₃	17.45	14.81		14.52	61
Cr(NCS) ₆ ³⁻	17.70	13.01		12.85 ^b	62, 68, 84, 91
Cr(CN) ₆ ³⁻	26.6 ^e	12.46		12.38 ^{b,d}	74, 75, 84, 91
		12.51		12.43	
Cr(Cl) ₆ ³⁻	13.7 ^e	(13.15) ^e	11.60		62
	13.06	14.48			
Cr(F) ₆ ³⁻	14.9 ^e	15.7 ^e	12.82		61
	15.06	15.67			
Cr(antip) ₆ ³⁺	15.72	14.03	11.90	13.95 ^b	62, 69
Cr(CH ₃) ₆ ³⁺	20.80			13.42	62
Cr(C ₆ H ₅) ₆ ³⁺	22.2			12.60	62
Cr(OD ₂) ₆ ³⁺	17.54 ^e	14.45 ^e		14.931 ^{b,d}	84, 86, 88
Cr(imid) ₆ ³⁺	16.26	14.4		14.4 ^b	77
Cr(dmf) ₆ ³⁺	16.849	14.43		14.455 ^b	76
Cr(acet) ₆ ³⁺	16.34	14.35 ^b		14.354 ^b	76
Cr(dma) ₆ ³⁺	15.31	14.144	12.00		76
Cr(tn) ₃ ³⁺	21.59	15.025 ^b		15.062 ^b	62, 71
Cr(en) ₃ ³⁺	21.85 ^c	14.945		14.975 ^b	62, 68, 84
Cr(ox) ₃ ³⁺	17.5 ^e	14.350		14.392 ^b	68
	18.06 ^e	14.451 ^d		14.451 ^b	78, 87
	17.63 ^e	14.470 ^d			
		14.448 ^f		14.448 ^{b,f}	79
		14.468 ^f		14.468 ^{b,f}	79
Cr(aca) ₃ (4.2°K)	18.4	12.95		12.84	62, 64, 66, 72
		12.882		12.873 ^{b,d}	
Cr(xant) ₃	16.2	12.9		12.6 ^b	82
Cr(dipy) ₃ ³⁺	22.0	13.75		13.74	62, 64
Cr(o-phen) ₃ ³⁺	23.8	13.70		13.72	62
Cr(hq) ₃				13.2 ^b	63, 64, 66, 100
				13.14 ^b	
Cr(malon) ₃	18.7			12.36 ^b	64-66
Cr(form) ₃	18.5			12.58 ^b	64-66
Cr(Br-aca) ₃	18.3	12.43		12.424 ^{b,d}	65, 66, 72, 73
Cr(Cl-aca) ₃	18.4			12.439 ^{b,d}	65, 66, 73
Cr(I-aca) ₃	18.4			12.361 ^{b,d}	65, 66, 73
Cr(NO ₂ -aca) ₃	18.6	12.865		12.837 ^{b,d}	65, 66, 72
Cr(CH ₃ -aca) ₃	18.4			12.23	64, 65
Cr(C ₂ H ₅ -aca) ₃	18.3			12.31 ^b	64-66
Cr(F ₃ -aca) ₃	17.8			12.34 ^b	64-66
Cr(F ₃ -aca) ₃	17.6			?	
Cr(bza) ₃	17.5			12.42 ^b	64-66
Cr(dbm) ₃	17.6			12.05 ^b	64-66
Cr(2-CH ₃ -hq) ₃				12.4 ^b	100
Cr(5,7-diBr-hq) ₃			20.5 ^b		100
Cr(biuret) ₃	17.24	14.35		14.37 ^b	76, 77
Cr(dtox) ₃ ³⁻	17.15	13.9	11.6		82
Cr(dtpa) ₃	16.6		11.2		82
Cr(dtb) ₃	16.0		10.6		82
Cr(tgl) ₃ ³⁻	15.7	11.8	11.2		82
Cr(dtc) ₂	15.6	12.3	11.0	12.1 ^b	82, 83
Cr(dtp) ₃	14.45	11.1			82
Cr(dsc) ₃	14.93	12.50	11.9		83
Cr(Sexant) ₃	15.25	12.70	12 ^s	12.65	83
Cr(dsp) ₃	13.75 ^j	12.6 ^j	12.05	(12.9)	83
		13.1			
Cr(biguanide) ₃ Cl ₃	20.70			13.195	99
				300°K	
Cr(NH ₃) ₅ Cl ²⁺	19.4 ^e	14.85 ^k		14.74 ^b	68, 84
CrBr ₂ (OH ₂) ₂ (NH ₃) ₂ ⁺				14.65	68
CrCl ₂ (OH ₂)(NH ₃) ₃ ⁺		14.6		14.55	68
Cr(NH ₂ CH ₂) ₅ Cl ²⁺	19.0			14.70 ^b	91

Table VI (Continued)

Compound ^a	Absorption		Emission		Ref
	⁴ T ₂	² E	⁴ T ₂	² E	
CrBr ₃	13.40 ⁱ 12.95	13.90 ⁱ	10.60		62
CrCl ₃	13.70	13.15 ^j	11.15		62
Cr(NH ₃) ₅ OH ₂ ³⁺	20.8 ^c	15.15 ^c		15.00 ^b	84
Cr(NH ₃) ₅ Br ²⁺	19.05 ^c			14.84 ^b	84
<i>trans</i> -Cr(NCS) ₄ (NH ₃) ₂ ⁻	1.93 ^k	13.41 ^k		13.33 ^b	84
Cr(NCS) ₄ (NH ₂ C ₆ H ₆) ₂ ⁻				13.16 ^b	84
Cr(tu) ₃ Cl ₃	13.2 14.7	12.7	(11.5) (10.9)		82
Cr(tgl)(OH ₂) ₅ ²⁺	17.5	14.8	12.1		82
CrF(OH ₂) ₅ ²⁺	16.69	14.86	11.20		61
CrF ₃ (OH ₂) ₃	16.42	14.93	12.50		61
CrF ₃ (OH ₂) ₃ · 2H ₂ O	16.42	14.99	12.80		61
CrF ₃ (OH ₂) ₃ · 0.5H ₂ O	16.42	15.08	12.80		61
CrF ₃ (OH ₂) ₃ · H ₂ O	16.34	15.04	12.80		61
CrF ₃ (OH ₂) ₂ ²⁻	15.85	15.13	12.65		61
Cr(ox)(en) ₂ ⁺	20.2 ^e			14.5	68
Cr(ox) ₂ (en) ⁻	18.8 ^e	14.5		14.44	68
<i>cis</i> -Cr(en) ₂ (OH)(OH ₂) ²⁺	19.4 ^k	14.7 ^k		14.95	68
		14.90			
<i>trans</i> -Cr(en) ₂ Cl ₂ ⁺	17.54 ^j			14.38 ^b	68, 84
<i>cis</i> -Cr(en) ₂ Br(OH ₂) ²⁺		14.64		14.53	68
<i>cis</i> -Cr(ox) ₂ (OH ₂) ₂ ⁻		14.55		14.53	68
<i>trans</i> -Cr(ox) ₂ (OH ₂) ₂ ⁻				14.24	68
<i>cis</i> -Cr(mal) ₂ (OH ₂) ₂ ⁻				14.52	68
<i>cis</i> -Cr(ox) ₂ (NH ₃) ₂ ⁻				14.44	68
<i>cis</i> -Cr(en) ₂ Cl ₂ ⁺	18.8			14.42 ^b	91
<i>cis</i> -Cr(en) ₂ Br ₂ ⁺	18.0			14.40 ^b	91
Cr(en)F ₄ ⁻	17.27	14.97	13.43	15.01 ^b	61
<i>trans</i> -Cr(en) ₂ (NCS) ₂ ⁺	20.1 ⁱ			13.74 ^b	84
V(dipy) ₃ ²⁺				12.27	95
MnCl ₆ ²⁻				12.19	95
Mo(urea) ₃ Cl ₃	21.50	14.90		9.140	105
Mo(urea) ₃ Br ₃	20.40	14.90		9.050	105
Mo(tu) ₃ Cl ₃	21.05	14.50		9.200	105

^a If temperature is not specified it is assumed to be 77°K. All values in kK. ^b For details of vibrational structure, lifetime, quantum yield, or temperature dependence for this band see appropriate section of text. ^c Indicated portion of absorption spectrum taken from ref 20. ^d Ion studied in a mixed crystal, see text. ^e More than one mixed crystal structure has been studied. Values are for AlCl₃ · 6D₂O : Cr³⁺. ^f Polarization study on single crystal (pure K₃Cr(ox)₃)—σ polarized. ^g ⁴T₂ absorption splits into two components for NaMg[Al(ox)₃] · 9H₂O : Cr³⁺. ^h Fluorescence from ligand. ⁱ See only in solid sample. ^j Indicated portion of absorption spectrum taken from ref 8. ^k Indicated portion of absorption spectrum taken from ref 5.

tion of absorption and emission is probably the result of a shift similar to that observed for Cr³⁺ fluorescence. In this case, though, an electron is transferred from an antibonding to a nonbonding orbital in absorption so that the metal–ligand distances are shorter in the excited state than in the ground state.¹¹⁸

Weak emission attributed to Ce³⁺ is seen at shorter wavelengths but it has a lifetime (<10⁻⁴ sec) at least two orders of magnitude less than that for Mn²⁺. The energy-transfer process with a net spin change of -1 involving one forbidden transition must involve a short range exchange mechanism.¹¹⁹

A later more detailed study¹²⁰ of this system was conducted using single crystals with different concentrations of Ce³⁺ and Mn²⁺. Both absorption and emission spectra were measured. At room temperature both Ce³⁺ and Mn²⁺ emissions are observed, but at 77°K very little of the former is seen and the intensity of the latter increases.

Some more recent investigations of glasses and minerals containing Mn²⁺ have again dealt with the question of the origin of the different colors of emission.^{121–124} In AlN–Al₂O₃:Mn²⁺ green emission again was assumed to mean tetrahedral sites while red meant octahedral.¹²¹ Since this questionable premise was used to determine, in part, the structure of the host compounds, the conclusions should be subject to further investigation. Another study of Mn²⁺ in phosphate and silicate glasses reported that bright orange phosphorescence resulted from octahedral sites and weak yellow phosphorescence originated from tetrahedral sites.¹²² In fluoroberyllate glasses (*i.e.*, 60BeF₂, 10AlF₃, 10CaF₂, 20MF, where M = Li, Na, Rb, or Cs) Mn²⁺ phosphorescence shifts toward higher energy with the change from Li to Cs to pure BeF₂

(121) I. Adams, T. R. AuCoin, and G. A. Wolff, *J. Electrochem. Soc.*, **109**, 1050 (1962).

(122) S. Kumar and P. Nath, *Trans. Indian Ceram. Soc.*, **25**, 12 (1966); *Chem. Abstr.*, **65**, 11929a (1966).

(123) G. A. Tsurikova, *Opt. Spectrosc.*, **24**, 151 (1968).

(124) A. N. Tarashchan, *Itogi Nauki: Geokhim., Mineral., Petrogr.*, **137**, (1966); *Chem. Abstr.*, **68**, 118092p (1968).

(118) L. E. Orgel, *J. Chem. Phys.*, **23**, 1958 (1955).

(119) D. Dexter, *ibid.*, **21**, 836 (1953).

(120) S. C. Sen and H. N. Bose, *Z. Phys.*, **201**, 368 (1967).

glass.¹²³ In contrast the authors claim that the absorption maximum of the same excited state, 4T_1 , shifts to lower energies for this series producing smaller Stokes' shifts for the more covalently bonded Mn^{2+} . It is stated also that the increased covalent bonding is consistent with a change from octahedral to tetrahedral symmetry. The change of the absorption peak to lower energy with decreasing $10Dq$ ($O_h > T_d$) contradicts, but the smaller Stokes' shifts and increased emission energies corroborate findings in "molecular" complexes¹¹⁵ (see next section).

A review of emission from Mn^{2+} in synthetic analogs of minerals concludes that it is not changes in coordination number of Mn that determine the color of emission, but that color changes can be explained with simple crystal field theory.¹²⁴ The complexity of the problem is evident. We know that Mn in known tetrahedral symmetry can give at least green and yellow emission. Small changes in crystal structure and/or local symmetry can change $10Dq$ as in Cr(III) complexes so that even within the two symmetries the emission wavelength may change significantly. Clearly, trends in wavelength shifts are not easy to predict because of the competitive effects of $-10Dq$, B , and C .

B. MOLECULAR COMPLEXES

The investigation of d^5 molecular complexes was stimulated by both the aforementioned work in ionic systems and an early theoretical treatment^{18,118} of $Mn(OH_2)_6^{2+}$. Molecular complexes can also adopt tetrahedral and octahedral symmetry. The emissions of tetrachloro-, bromo-, and iodomanganese-(II) and two mixed dihalodiphosphine complexes have been compared to those of chloropyridyl, chloroamine, and hexa-aqua complexes and doped Na phosphate glass.¹¹⁵ The members of the first group all have T_d microsymmetry (or less) while the latter group have O_h . Both emission from and absorption to the 4T_1 state shift to lower energy when the symmetry of Mn^{2+} changes from T_d to O_h , in agreement with the increased value of $10Dq$. The Stokes' shifts between absorption and emission maxima were found to increase as $10Dq$ increased. This simply means that the repulsion between metal and ligand, established when an electron is in an antibonding orbital (for T_d these are t_2 orbitals), is greater when the ligand exerts a greater field strength on the metal. When an electron is removed from the antibonding orbital, as in the 4T_1 transition, the complex collapses more for strong field than for weak field ligands.

Some other studies of mixed haloamine complexes have been reported.¹²⁵⁻¹⁸¹ The pioneer investigation¹²⁵ of these compounds concerned the activation of phosphors with $MnCl_2$ or $MnSO_4$. Red or green emission was observed when phosphors prepared with pyridine, the manganese salt, and the acid of the salt anion were irradiated in the near-ultraviolet. The chloride phosphor luminesced at room temperature. Later it was found that the color of the emission depended on

the reactant proportions used to prepare the phosphors.¹²⁶ Thus if $MnCl_2$, pyridine, and HCl were mixed in a 1:2:2 ratio (producing the complex $(C_5H_5NH)_2[MnCl_4]$) red emission resulted; when the three components were in equal proportions ($MnCl_2 \cdot C_5H_5NHCl$) the emission was green. The studies have been extended to include other amines (*i.e.*, methyl- and ethylamine, etc.)¹²⁷ and other halides¹²⁸ (see Table VII). The variations in the wavelengths of the maxima of the emission bands are due to variations in $10Dq$, B , and C caused by structural and/or ligand field strength changes and also to nephelauxetic effects, but the authors fail to comment on any of these points or on the transitions responsible for emission. They have demonstrated that the bands show exponential decay times of the order of milliseconds and that no vibrational fine structure is evident in any of the emissions.¹²⁹⁻¹⁸¹ The results support assignment of the emission as phosphorescence of both octahedral and tetrahedral Mn^{2+} complex centers.

The emission of Mn^{2+} and the transfer of energy from Mn^{2+} to Eu^{3+} in different fluoride complexes are known.¹³²⁻¹³⁴ When MnF_2 is irradiated in any of five different absorption bands emission, ${}^4T_{1g} \rightarrow {}^6A_{1g}$, is observed. At liquid helium temperature (4.2°K) the emission maximum is at 581 μ m. As the temperature is raised gradually to about 200°K the position of the maximum shifts to 651 μ m with two distinct jumps in this shift occurring at ~ 30 and 100°K. The band widths remain approximately constant, but the overall intensities drop at the inflection points in the curves (the phenomenon is seen also with $KMnF_6$).¹³² The explanation of these observations is not clear¹³³ but must be related to changes in the symmetry around the Mn^{2+} ion. No evidence is presented with regard to any phase changes in the solid over the temperature range studied.

When trivalent europium (f^6) ions are incorporated into the manganese fluoride lattice, energy transfer from Mn^{2+} to Eu^{3+} is observed.^{133,134} Also energy transfer from Mn^{2+} to Nd^{3+} (f^3) is observed in certain glasses.¹³⁵ Little discussion of these transfers is presented in the various articles; however, all of them, along with studies of Cr^{3+} and Co^{3+} , must be considered in the application of existing theories, or in the formulation of new ones, to explain the curious phenomena which seem to be unique to energy transfer to or from metal ion complexes.

Oxinate complexes of Mn^{2+} are known to luminesce with $\bar{\nu}_{max}$ about 20 kK and with small emission quantum yields.¹⁰⁰ As the manganese is tetracoordinated and presumably tetrahedral the emission could be assigned to the ${}^4T_1 \rightarrow {}^6A_1$ transition, although the authors assigned it to a ligand emission. The lifetime of the emission was not reported but such measurements might well distinguish between ligand fluorescence (10^{-8} - 10^{-9} sec) and metal phosphorescence ($>10^{-6}$ sec).

In the study of the energy levels of d^6 metals¹¹⁸ it was mentioned that they act as efficient quenchers of luminescence of organic ligands or free molecules in solution. Infrared emission was predicted for Fe(III) systems, but apparently no work has been done with either Fe(III) or Mn(II) emission under appropriate conditions. The spin changes necessary for energy

(125) S. Schlivitch, *C. R. Acad. Sci., Paris*, **245**, 2047 (1957).

(126) K. Nikollitch, H. P. de la Garanderie, and S. Schlivitch, *ibid.*, **250**, 4143 (1960).

(127) H. P. de la Garanderie, *ibid.*, **254**, 2739 (1962).

(128) H. P. de la Garanderie, *ibid.*, **259**, 4601 (1964).

(129) X. Velachevitch, S. Schlivitch, and K. Nikollitch, *ibid.*, **257**, 3855 (1963).

(130) H. P. de la Garanderie, *ibid.*, **260**, 104 (1965).

(131) H. P. de la Garanderie, *Int. Symp. Lumin., Phys. Chem. Scintill., Proc.*, **264** (1966); *Chem. Abstr.*, **67**, 121257f (1967).

(132) W. W. Holloway, Jr., M. Kestigian, R. Newman, and E. W. Prohovsky, *Phys. Rev. Lett.*, **11**, 82 (1963).

(133) V. V. Eremenko, E. V. Matyushkin, and S. V. Petrov, *Phys. Status Solidi*, **18**, 683 (1966).

(134) S. Shionoya and M. Hirano, *Phys. Lett.*, **A26**, 533 (1968).

(135) N. T. McLamed, Symposium on Optical Masers, Toronto, Canada, May 6-7, 1964, from ref 103a.

Table VII
Absorption and Emission Spectral Maxima of d⁵ Metal Compounds

Compound	Absorption to ^a		Emission from ^{b,c} ⁴ T ₁	Ref
	⁴ T ₂	⁴ T ₁		
Zn ₂ SiO ₄ :Mn ²⁺			19.04	109
Be ₂ SiO ₄ :Mn ²⁺			16.39 (?)	109
ZnS:Mn ²⁺	19.683	17.891	17.891	111
ZnSe:Mn ²⁺	18.8 (?)		16.10	114
CaF ₂ Ce ³⁺ Mn ²⁺			~18.2 (⁴ G, 90°K)	117
AlN:Mn ²⁺			Green	121
Al ₃ O ₃ N:Mn ²⁺			Orange	122
PO ₄ :Mn ²⁺ glass			Yellow	122
SiO ₂ :Mn ²⁺ glass				122
60BeF ₂ ·10AlF ₃ · 20LiF:0.05% Mn ²⁺			~16.0	123
20CsF:0.05% Mn ²⁺			~16.9	123
BeF ₂ :0.05% Mn ²⁺			~17.4	123
MnCl ₄ ²⁻	23-23.6	21-21.5	18.40	115
MnBr ₄ ²⁻	22-23	20.7-21.3	19.25	115
MnI ₄ ²⁻	21.1-21.4	21.14	18.72	115
MnBr ₂ (tpp) ₂	22.5-22.8	21.5-21.9	19.40	115
MnI ₂ (tpp) ₂	22.1-22.5	21.1-21.4	19.20	115
MnCl ₂ (py·HCl)	21.1	19.23	17.10 (?), 15.3g*	115, 127*
Mn ²⁺ NaPO ₃ Ce ³⁺	21.5	19.1	17.20	115
MnCl ₂ (am·HCl)H ₂ O		~19	15.8-16.7	125
am = CH ₃ NH ₂			Diffuse band (0.20)	127
C ₂ H ₅ NH ₂			16.47 (0.26)	127
quinoline			16.12 (0.31)	127
isoquinoline			15.87 (0.36)	127
acridine			16.80	127
MnCl ₂ (am·HCl)				
am = (CH ₃) ₃ N			15.26 (0.27)	127
aniline			14.92 (0.37)	127
toluidine			15.19 (0.17)	127
pyridine			15.38 (0.029)	127
picoline			15.24 (0.33)	127
piperidine			15.31 (0.32)	127
MnCl ₂ ·2am·2HCl				
am = pyridine			19.04 (0.84)	127
quinoline			19.04 (0.43)	127
acridine			19.12	127
picoline			19.08 (0.56)	127
piperidine			18.58 (2.8)	127
CH ₃ NH ₂			16.66 (0.045)	127
C ₂ H ₅ NH ₂			16.61 (0.12)	127
MnBr ₂ (am·HBr)				
am = pyridine			15.74 (0.310)	128
C ₂ H ₅ NH ₂			16.47 (0.203)	128
MnBr ₂ ·2am·2HCl				
am = pyridine			19.23 (0.275)	128
piperidine			18.86 (0.373)	128
MnCl ₂ ·alk				
alk = papaverine			16.44	129
narcotine			15.15	129
cotarnine			15.79	129
hydrastinine			16.00	129
pilocarpine			15.38	129
MnCl ₂ (alk) ₂				
alk = papaverine			20.32	129
narcotine			19.23	129
pilocarpine			18.69	129
MnF ₂	23.50		17.21 (4°K)	132
		19.44	15.36 (150°K)	132
KMnF ₃			17.24*, 16.89 (4°K)	132, 134*
			15.57 (150°K)	132

^a Absorptions reported for those cases in which they are included in the emission reference. All values in kK. ^b Decay times in msec are given in parentheses. ^c Where values and references are marked with an asterisk it means that the marked value was taken from the marked reference.

thus far studied are of the "molecular" type. Therefore, we have divided the material into seven sections: general studies, hexacyanide complexes, ruthenium(II), osmium(II), rhodium(III), irridium(III), and platinum(IV) complexes.

A. GENERAL STUDIES

There is one report of a high-spin d^6 metal complex in the literature.¹⁴⁰ Fe(II) in ZnS is in a tetrahedral ligand field and $10Dq$ is small enough that the lowest electronic transition (${}^5T_{2g} \leftrightarrow {}^5E$) is in the infrared region with emission at 2400–3000 cm^{-1} and absorption at 3000–4500 cm^{-1} . The ground state (5E) is split either by spin-orbit coupling or by reduced molecular symmetry, perhaps from a Jahn-Teller effect, and different components are observed in the emission spectrum. The average splitting is $18 \pm 4 \text{ cm}^{-1}$. There is little if any temperature dependence of the emission between 5 and 77°K, but the intensity goes to zero at 300°K. The intensity does not depend on iron concentration in the range 10^{-4} – 10^{-2} mole fraction of FeS. The 0–0 band of the emission is the most intense. All of these observations support the hypothesis that the transition is symmetry allowed and that the complex is tetrahedral.

Three summaries of individual groups' research in d^6 complexes have been published recently.^{139,141,142} While most of the compounds summarized will be treated individually in subsequent sections, a few general comments will be made here. Complexes of trivalent cobalt, rhodium, and iridium and tetravalent platinum¹³⁹ show phosphorescence ${}^3T_{1g} \rightarrow {}^1A_{1g}$ with maxima between 14.0 and 18.0 kK (although we suspect the latter figure may be greater for some Pt(IV) complexes). An example of this behavior is $\text{Ir}(\text{py})_2\text{Cl}_4^-$ which gives a broad band (half-width $\sim 3.0 \text{ kK}$), with a maximum at about 650 $\text{m}\mu$ (14.6 kK). There is no vibrational structure and the statement was made that this is general behavior for all interconfigurational (*i.e.*, d–d) bands.¹³⁹ We shall see in section G, however, that PtF_6^{2-} , PtCl_6^{2-} , and PtBr_6^{2-} all show discernable vibrational fine structure with characteristic spacings (see Figure 10).

Complexes of divalent ruthenium and osmium with organic ligands exhibit charge transfer emission and show much more definite vibrational structure.¹³⁹ It is our opinion that vibrational fine structure is a general phenomenon that depends on the nature of the ligands and on the metal-ligand molecular framework, not only on the type of electronic transition involved in the emission. In all of these electronic transitions an electron is removed from a bonding or nonbonding orbital and placed in an antibonding orbital. Therefore, there is a change in average metal-ligand bond lengths and transitions occur to upper vibrational levels.¹⁴³

The energy levels of a d^6 metal in an octahedral field, with emphasis on those levels which may be involved in luminescence, have been discussed.¹⁴¹ Included in this discussion are implications of intramolecular energy transfer resulting from absorption of a photon in a ligand localized transition and emission from a metal localized transition. However, the actual distinction between ligand and metal states becomes rather arbitrary, especially for molecules with extensive π

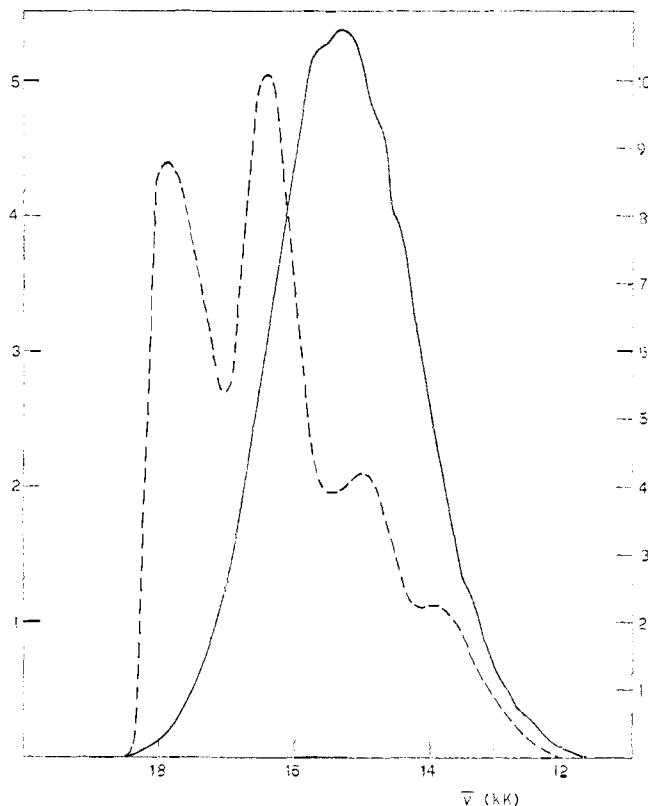

Figure 10. Representative emission spectra of d^6 transition metal coordination complexes. $[\text{Ru}(o\text{-phen})_3]_2$ in glassy solution at 77°K (---, left scale) (after ref 153). $\text{K}_2[\text{PtCl}_6]$ solid powder at 77°K (—, right scale). (Ordinate: Intensity, arbitrary units.)

back-bonding (see Figure 9). In contrast to the rare earth ions in which the f orbitals involved in the luminescence have a small role in bonding, the transition metal d orbitals often have quite strong interactions with the ligand systems.

Complexes of Co(III) show little photochemical activity when excited in the d–d transitions.⁵ This may result from facile radiationless processes mentioned above. The heavier metals at higher field strength (and with organic ligands) are also photochemically stable but luminesce even in solution at room temperature.¹⁴² Some Rh(III) triplet states have been located by luminescence studies.

B. HEXACYANIDE COMPLEXES

The physics and chemistry of cyanide complexes often seem to depend more on the CN^- ligand than on the metal ion. For example, the values of $10Dq$ for ferro- or ferricyanide are very similar and are close to those for $\text{Mn}(\text{CN})_6^{3,4-}$ and $\text{Co}(\text{CN})_6^{3-}$ (33.8, 34.95, 34.0, 30.0, and 34.5 kK, respectively.)¹⁴⁴ Of major importance in the behavior of the cyanides must be the extensive π back-bonding that occurs between the metal d electrons and the antibonding π orbitals of the cyanide system. π bonding with reference to the molecular orbital system of Figure 9 has been mentioned for *o*-phenanthroline and di-pyridine complexes. The same diagram may be applied to cyanide complexes with some modifications. The π – π^*

(140) G. A. Slack and B. M. O'Meara, *Phys. Rev.*, **163**, 335 (1967).

(141) G. A. Crosby, *J. Chim. Phys.*, **64**, 160 (1967).

(142) G. A. Crosby, *U. S. Govt. Res. Rep.*, **68**, 58 (1968); *Chem. Abstr.*, **69**, 31822y (1968).

(143) C. Furlani, *Coord. Chem. Rev.*, **1**, 51 (1966).

(144) J. J. Alexander and H. B. Gray, *J. Amer. Chem. Soc.*, **90**, 4260 (1968).

separation¹⁴⁶ is greater for free CN⁻ than for dipy or *o*-phen, so the t_{1u} molecular orbital is above the e_g^* . Also CN⁻ has two additional orbitals which are represented by the dashed lines in the figure.

An example of π -bonding effects on the magnitude of $10Dq$ is the following. Changing the charge of the metal ion from +2 to +3 as in ferro- and ferricyanide causes an increase in σ bonding and an elevation of the σ^* (e_g) level. This same change reduces the number of d electrons involved in π back-bonding and provides a "hole" for ligand to metal π bonding. Both π effects destabilize the $\pi(t_{2g})$ level. The net effect is a simultaneous movement of $\sigma^*(e_g)$ and $\pi(t_{2g})$ to higher energies but not a necessarily significant change in their splitting.

Two d⁶ hexacyanide complexes, with Co(III) and Ru(II), have been found to luminesce.^{146, 147} Their behaviors are similar but demonstrate that although changes in metal within a given transition series do not affect $10Dq$ and/or C , changes from the first to the second row must significantly alter these parameters. Unfortunately data available on ligand field parameters¹⁴⁴ for Co(CN)₆³⁻ do not fit the luminescence results,¹⁴⁶ but do give an indication that the low energy of the cobalt emission, compared to that for ruthenium,¹⁴⁷ reflects changes in both $10Dq$ and C .

Hexacyanocobaltate(III) gives a broad (~ 2 kK) structureless emission band with $\bar{\nu}_{\max}$ at 14.40 kK when excited in either spin-allowed or spin-forbidden absorption bands (see Table VIII).¹⁴⁶ Weak emission from the solid at room temperature increases in intensity as the temperature is reduced to 77°K. The lifetime¹⁴⁷ of the emission is 6.8×10^{-4} sec.

The analogous hexacyanoruthenate(II) shows a similar emission ($\bar{\nu}_{\max} = 22.65$ kK and $\bar{\nu}_{1/2} = 6.0$ kK) both in the solid and in glassy solution.¹⁴⁷ A low intensity absorption band ($\bar{\nu}_{\max} = 31.0$ kK) and the emission are mirror images; the origin of both bands is taken to be 28 kK. The lifetime for the heavier metal emission is longer, 3.1×10^{-2} sec, but the similarities between the two complexes lead to the assignment of both bands as phosphorescence (${}^3T_{1g} \rightarrow {}^1A_{1g}$). It may well be that the longer lifetime in Ru(CN)₆⁴⁻ reflects the decreased probability of radiationless deactivation resulting from the larger separation of ${}^3T_{1g}$ and ${}^1A_{1g}$. (See above discussion of energy levels.) It follows that the weak absorption of the Ru(II) complex at 31 kK is not singlet-singlet as previously assigned.¹⁴⁸ From the new assignment revised values of $10Dq$, B , and C were calculated.¹⁴⁷

C. RUTHENIUM(II)

1. Nitrogen Coordinated Heterocyclic Chelates

Two early reports concern the emission of dipryridyl and *o*-phenanthroline derivative chelates in solution.^{149, 150} [Ru(dipy)₃]Cl₂ emits as a narrow band with a maximum at approximately 15 kK. The emission was assigned to a π^* (mostly ligand) $\rightarrow \pi(t_{2g})$ transition.¹⁴⁹ Since the latter molecular orbitals (t_{2g}) are primarily metal d orbitals, the transition is charge transfer in nature. An analytical method for Ru(II) in solution

was devised by making use of the intense room-temperature emission.¹⁵⁰ An investigation of a series of *o*-phen and dipy derivatives proved that the 5-methyl-1,10-phenanthroline chelate emits with the greatest intensity. Pt(IV) and Rh(III) do not interfere but Fe(II), Ce(IV), and Mn(II) do interfere with the determination of Ru(II). If the former luminesce, it would be in the same wavelength region while if the latter luminesce it would be at longer λ or at lower temperature. In this early work no vibrational structure was observed but the spectrograph slits were very wide. The activation spectra, again with wide slits, reproduced the absorption spectra.

A more recent investigation¹⁵¹ has produced more detailed information on the wavelengths and lifetimes of the emission from [Ru(dipy)₃]Cl₂ and [Ru(*o*-phen)₃]I₂·H₂O. Two weak bands in the absorption spectrum of the dipy compound were assigned to singlet and triplet d-d transitions (${}^1T_{1g} \leftarrow {}^1A_{1g}$ and ${}^3T_{1g} \leftarrow {}^1A_{1g}$). The emission spectra of the dipy and *o*-phen compounds are quite similar; both show four distinct peaks and a vibrational spacing of ~ 1.30 kK (see Figure 10). A diagram is given of the energy levels of the d⁶ metal and shows their splitting in an octahedral field.

The emission lifetimes of Ru(dipy)₃³⁺ and Ru(*o*-phen)₃²⁺ are of the order of 10^{-5} sec, a range normally associated with a spin-forbidden transition. However, the authors pointed out that this value could also represent a spin-allowed but parity-forbidden transition.¹⁵¹ With this in mind and the recognition that the lowest spin-forbidden absorption occurred at lower energy than the emission, the latter was assigned as d-d fluorescence, ${}^1T_{1g} \rightarrow {}^1A_{1g}$.

In a later paper the same authors reported that the lowest energy absorption band assigned to a triplet (${}^3T_{1g}$) transition was actually due to an impurity and that the calculated $10Dq$ (~ 19 kK) based on the ${}^1T_{1g}$ - ${}^3T_{1g}$ splitting and the ${}^1T_{1g}$ energy was far too low.¹⁵² They then reassigned the emission to the $\pi(t_{1u}) \rightarrow \pi(t_{2g})$ CT transition. The question of this assignment is discussed further below.

2. Mixed Ligand Complexes

In a continued effort to determine the transition responsible for Ru(II) emission, a series of mixed ligand complexes was investigated.¹⁵²⁻¹⁵⁴ The emission was assigned previously to a d-d transition which suggested that systematic changes in the ligand field strength of X in Ru^{II}(dipy)₂X₂ (where X = CN⁻, py, en/2, Cl⁻, ox²⁻/2, and dipy/2) would produce systematic shifts in the frequency of the emission maxima.¹⁵³ In all of the complexes the emission spectra were similar with half-widths of ~ 5 kK and four prominent peaks spaced ~ 1.3 kK apart. In contrast to the hypothesis, $\bar{\nu}_{\max}$ did not follow the spectrochemical series (*i.e.*, the energy of the $\sigma^*(e_g)$ level) nor did it follow exactly the charge transfer energy. However, the correlation with the CT bands was considerably better than that with the spectrochemical series.

From the above study¹⁵³ one conclusion is certain; the energy of the emission is noticeably reduced when the degree of π back-bonding is reduced. Thus in the tris chelates the

(145) H. B. Gray and N. A. Beach, *J. Amer. Chem. Soc.*, **85**, 2922 (1963).

(146) M. Mingardi and G. B. Porter, *J. Chem. Phys.*, **44**, 4354 (1966).

(147) M. Mingardi and G. B. Porter, *Spectrosc. Lett.*, **1**, 293 (1968).

(148) M. D. Robin, *Inorg. Chem.*, **1**, 377 (1962).

(149) J. P. Paris and W. W. Brandt, *J. Amer. Chem. Soc.*, **81**, 5001 (1959).

(150) H. Veening and W. W. Brandt, *Anal. Chem.*, **32**, 1426 (1960).

(151) G. A. Crosby, W. G. Perkins, and D. M. Klassen, *J. Chem. Phys.*, **43**, 1498 (1965).

(152) D. M. Klassen and G. A. Crosby, *Chem. Phys. Lett.*, **1**, 127 (1967).

(153) D. M. Klassen and G. A. Crosby, *J. Chem. Phys.*, **48**, 1853 (1968).

(154) J. N. Demas and G. A. Crosby, *J. Mol. Spectrosc.*, **26**, 72 (1968).

introduction of oxalate, or in the mixed complexes changing from $X = \text{py}$ or CN^- to $X = \text{Cl}^-$, $\text{en}/2$, or $\text{ox}^{2-}/2$, produced red shifts of $\bar{\nu}_{\text{max}}$ from 17 to 14 kK. The effects of π bonding on the energy separation $\sigma^*(e_g) - \pi(t_{2g})$ or $\pi^*(t_{1u}) - \pi(t_{2g})$, as explained in section B, primarily are due to variation of the $\pi(t_{2g})$ level. This variation affects both d-d and charge transfer transitions; it appears that the only certain way to solve the problem of the emission assignment is to find a method of changing only the σ bonding in the complex (*i.e.*, the $\sigma^*(e_g)$ level).

The emission lifetimes of the mixed ligand complexes were also measured.¹⁵⁴ The values ranged from 0.6×10^{-6} sec for $[\text{Ru}(\text{dipy})_2\text{ox}]$ to 5.27×10^{-6} sec for $\text{Ru}(\text{dipy})_2(\text{py})_2^{2+}$. As with the higher symmetry tris chelates these values could represent d-d fluorescence or $\pi^* - \pi(t_{2g})$ phosphorescence. The final assignment¹⁵⁴ of the Ru(II) emission has been to the $\pi^*(t_{1u}) \rightarrow \pi(t_{2g})$ (CT) phosphorescence, and the shortened triplet lifetimes were attributed to spin-orbit (heavy atom) effects of ruthenium.

Assuming that this assignment is correct for the emission and noting the overlap of most of the absorption and emission spectra for the Ru(II) complexes,¹⁵³ we suggest that the weak, longer wavelength absorption is not d-d but actually the triplet absorption of the $\pi^*(t_{1g}) \leftarrow \pi(t_{2g})$ transition. This CT triplet level is similar to the one proposed¹⁵⁵ in the photosensitized reduction of $\text{Co}(\text{NH}_3)_6^{3+}$ (although CTTL rather than CTTM), but is apparently populated directly in the heavier metal complexes where the ligand field levels are at higher energies.

It is interesting to consider the emission behavior of the free ligands dipyrindine and *o*-phenanthroline and compare their spectra to the emission of the complexes. The phosphorescence¹⁵⁶ of 2,2'-dipyridine in *n*-heptane at 77°K has a maximum (0-0 transition) at 23.5 kK. There is considerable fine structure on the emission band located between 23.5 and 18.4 kK. Different vibrational frequencies are reported but those at 1240, 1310, and 1450 cm^{-1} are of particular significance when compared to the structure in the emission of the Ru(II) complex. *o*-Phenanthroline also phosphoresces at low temperature in a glassy solution.¹⁵⁷ The origin of the emission is at 22.21 kK; the emission is virtually identical with that of phenanthrene with a blue shift of 450 cm^{-1} . The latter emission must be due to a $\pi^* - \pi$ transition since there are no non-bonding electrons; thus it is concluded that the *o*-phen emission is also $\pi^* - \pi$ phosphorescence. The profile of the band is quite similar to those for Ru(II), Os(II), and Pt(II) (see section XIII.B.2) complexes, also measured in glassy solution, with four distinct peaks and vibrational spacings of 416, 1351, 1611, and perhaps 827 cm^{-1} .

It can be seen from the molecular orbital diagram (Figure 9) that the ligand orbital from which emission originates (π^*) can be stabilized in the complex with respect to the free ligand, while the ground state (π) correlates to a higher energy $\pi(t_{2g})$ level. (There are two $\pi(t_{2g})$ molecular orbitals, both occupied, the lower of which is mostly ligand π , the upper mostly metal d.) The net effect (stabilization of the upper level and destabilization of the lower) is a smaller energy separation

and a red shift (*i.e.*, 22 to 17 kK) of the emission. Our conclusion thus concurs with the assignment^{158, 154} of the emission of the metal complexes to $\pi^*(t_{1u}) \rightarrow \pi(t_{2g})$ phosphorescence.

To conclude the discussion of $\text{Ru}(\text{dipy})_3^{2+}$ emission we cite an instance where it was generated chemically.¹⁵⁸ $\text{Ru}(\text{dipy})_3^{3+}$ can be made in acid solution by oxidation of the Ru(II) complex with PbO_2 . Although the tervalent ion could not be isolated in the solid, when it was added in solution to strong base the characteristic $\text{Ru}(\text{dipy})_3^{2+}$ emission was observed. The reduction of $\text{Ru}(\text{dipy})_3^{3+}$ is probably an outer sphere reduction.¹⁵⁹ If the electron entered the metal directly the easiest path would be to a half-filled t_{2g} orbital projecting between the ligands. This would give ground-state $(\text{Ru}(\text{dipy})_3^{2+})$ directly, hence no emission. On the contrary, we suggest that the electron enters the π system of the organic ligands and is eventually transmitted to the metal in a "charge-transfer" transition.¹⁶⁰

One other Ru(II) complex emission has been studied.¹⁶¹ The absorption and emission of $[\text{Ru}(\text{dpp})_2\text{Cl}_2]$ consist of pairs of bands with splittings of 9-10 and ~ 4 kK, respectively. The splittings are ascribed to a reduction of the symmetry of the complex from O_h . Two states, ${}^1A_{2g}$ and 1E_g , are derived from the ${}^1T_{1g}$ level. This luminophor may have a $10Dq$ value at the very limit (~ 24 -25 kK) for d-d emission (*vide supra*), although for an unknown reason fluorescence appears to be favored over phosphorescence.

D. OSMIUM(II)

$[\text{Os}(\text{dpp})_2\text{Cl}_2]$ behaves in a fashion analogous to the Ru(II) complex with the addition that in this case a triplet d-d absorption band is evident.¹⁶¹ This triplet band is at a lower energy than the emission so it is concluded that both the Ru(II) and Os(II) complexes exhibit d-d fluorescence ${}^1T_{1g} \rightarrow {}^1A_{1g}$. The emission of the Os complex is to the blue of the Ru complex as expected considering the larger $10Dq$ for the third-row element.

Osmium(II) dipyrindine and *o*-phenanthroline complexes have also been found to luminesce.^{162a} Their behavior is again very similar to the analogous ruthenium compounds. In contrast to the above example of d-d fluorescence, these Os emissions are noticeably red shifted as are the Os CT absorption bands.

E. RHODIUM(III)

Complexes of Rh(III) which have been found to luminesce may be divided into two classes, those which show only metal perturbed ligand emission and those which show metal ion d-d emission. $\text{Rh}(\text{o-phen})_3^{3+}$, although still d^6 , has a different oxidation-reduction chemistry than the *o*-phen complexes of Ru(II) and Os(II). The energy required to oxidize Rh(III) is

(155) A. Vogler and A. W. Adamson, *J. Amer. Chem. Soc.*, **90**, 5943 (1968).

(156) Kh. I. Mamedov and R. Z. Laippanov, *Zh. Prikl. Spektrosk.*, **7**, 49 (1967); *Chem. Abstr.*, **68**, 100349f (1968).

(157) J. S. Brinen, D. D. Rosebrook, and R. C. Hirt, *J. Phys. Chem.*, **67**, 2651 (1963).

(158) D. M. Hercules and F. E. Lytle, *J. Amer. Chem. Soc.*, **88**, 4745 (1966).

(159) (a) H. Taube, *Can. J. Chem.*, **37**, 129 (1959); (b) A. G. Sykes, *Advan. Inorg. Chem. Radiochem.*, **10**, 153 (1967).

(160) The idea of electron migration through a π system of ligands is not new for redox reactions; see, for example, F. Nordmeyer and H. Taube, *J. Amer. Chem. Soc.*, **90**, 1162 (1968).

(161) D. M. Klassen and G. A. Crosby, *J. Mol. Spectrosc.*, **25**, 398 (1968).

(162) (a) G. A. Crosby, D. M. Klassen, and S. L. Sabath, *Mol. Crystals*, **1**, 453 (1966); (b) G. A. Crosby and D. H. W. Carstens, "Molecular Luminescence," E. C. Lim, Ed., W. A. Benjamin Co., New York, N. Y., 1969; (c) M. K. DeArmond and J. E. Hillis, *J. Chem. Phys.*, **49**, 466 (1968).

greater than that required for the divalent ions, and the CT absorption bands are at higher wave numbers for Rh(III). Thus, for Rh(*o*-phen)₃³⁺ the ligand $\pi^*-\pi$ transition is actually the lowest energy transition and gives rise to phosphorescence,^{162b} which is only slightly shifted with respect to that of the free ligand (22.3 kK, complex, *vs.* 22.2 kK, free ligand). Ligand localized emission has also been reported for some acetylacetonate derivative chelates of trivalent rhodium.^{162a}

The substitution of one *o*-phen group by two chlorides to form *cis*-Rh(*o*-phen)₂Cl₂⁺ results in a decrease in the average ligand field strength around Rh(III) so that now d-d transitions are found at lower energy than the ligand transitions.^{162b} (In the original paper emissions of *trans*-Rh(*o*-phen)₂Cl₂⁺ and Ir(*o*-phen)₃³⁺ were reported. However, in a private communication, Professor Crosby has informed us that the actual materials were *cis*-Rh(*o*-phen)₂Cl₂⁺ and *cis*-Ir(*o*-phen)₂Cl₂⁺, respectively.) The mixed complex shows d-d phosphorescence with $\bar{\nu}_{\max}$ at about 13.0 kK and lifetime of $20.2 \pm 1.2 \times 10^{-6}$ sec in glassy solution at low temperature.^{162b}

Two other Rh(III) complexes are reported to produce metal localized phosphorescence. Rh(py)₂Cl₄⁻ phosphoresces with a maximum at 15.15 kK¹⁶⁹ and Al₂O₃:Rh³⁺ has a maximum at 14.7 kK.¹⁶³ The lifetime of the latter emission changes from 1.6×10^{-8} sec at 77°K to 0.6×10^{-8} sec at 300°K. If octahedral microsymmetry is assumed, all of these metal ion emissions correspond to the ³T_{1g} → ¹A_{1g} transition.

F. IRIIDIUM(III)

Ir(dipy)₃³⁺ and *cis*-Ir(*o*-phen)₂Cl₂⁺ emit with four peaked spectra, similar to the Ru²⁺ and Os²⁺ complexes but at higher energies.^{141, 162a, 164} (There is some question as to the composition of the *dipy* complex. It too may be *cis*-Ir(dipy)₂Cl₂⁺.) The increased charge of iridium should make it more difficult to transfer an electron from the metal to the ligands,²⁰ so the CTTL absorption and emission should be at higher energies for Ir³⁺ than for either Ru²⁺ or Os²⁺. In view of the correlations that have been made for Ru(II) complexes^{153, 154} and the similarities and trends among ruthenium, osmium, and iridium complexes, it seems quite evident that the emissions of all of these heterocyclic organic chelates of d⁶ metals, except Rh(III), are indeed charge transfer phosphorescences. A CT transition for Ir(III) but not Rh(III) is consistent with the greater tendency for Ir(III) to be oxidized to Ir(IV).^{162b}

Two other Ir(III) complexes are known to emit. Ir(py)₂Cl₄⁻ has already been discussed. The solid IrCl₃ which has an Ir(III) surrounded by six Cl⁻ ions shows a broad band emission¹⁶⁵ with $\lambda_{\max} \approx 1000$ m μ .

G. PLATINUM(IV)

Studies of emission spectra now include stable complexes of practically all of the d⁶ metals. Both pure and mixed crystals containing the octahedral PtX₆²⁻ ion have been found to luminesce.¹⁶⁶ The wavelength of the maximum and the efficiency of the emission depend on the environment and, more specifically, on the cation of the complex. Potassium, rubidium, and cesium salts of PtCl₆²⁻ and K₂[SnCl₆]:Pt⁴⁺ were

found to emit, but the acid H₂PtCl₆ and the ammonium salt did not.¹⁶⁶ In another study the NH₄⁺ salt was found to emit at a lower energy than the other forms.¹⁶⁷

The red emission of K₂[PtCl₆] is strong at 77°K (clearly visible with the eye) and is seen even at room temperature¹⁶⁵⁻¹⁶⁷ (see Figure 10). It is slightly more intense when excited with 436- than with 365-m μ light.¹⁶⁵ The maximum¹⁶⁸ of the emission is between 14.5 and 15 kK and the half-width changes from about 4.6 kK at 300° to 2.5 kK at 77°K. Vibrational fine structure is reported for PtCl₆²⁻ at 4.2 and 77°K with a recurrent spacing of 305 ± 10 cm⁻¹.

K₂[PtBr₆], Cs[PtF₆], and K₂[Pt(SCN)₆] also luminesce in the red region of the spectrum.^{166, 167} Fine structure was observed for the first two compounds with average spacings of 190 ± 10 and 500 ± 50 cm⁻¹, respectively. The fluoride emission is at higher energy and the bromide and thiocyanate at lower energy than the chloride, the same order as the spectrochemical series, but the data to date are scarce and reliable correlations cannot be made.

The lifetime of the PtCl₆²⁻ emission is $3-8 \times 10^{-4}$ sec. From this value and the relationship of the emission and absorption spectra the emission is assigned as ³T_{1g} → ¹A_{1g} phosphorescence. Platinum, being heavier than ruthenium, should have a larger spin-orbit coupling constant. Therefore, it is not surprising that the ³T_{1g} lifetime of PtCl₆²⁻ is shorter than that of Ru(CN)₆⁴⁻. In addition, 10Dq in PtCl₆²⁻ (approximately 29 kK, ref 20) is smaller than in both Co(CN)₆³⁻ and Ru(CN)₆⁴⁻, and radiationless deactivation of ³T_{1g} should be more probable.

The compound [Pt(NH₃)₃Cl₃]Cl, but not [Pt(en)₂Cl₂]Cl₂ or [Pt(NH₃)₄(SCN)₂](NO₃)₂, has been observed to emit¹⁶⁵ with λ_{\max} 590 m μ (16.9 kK). This significant shift to shorter wavelength compared to λ_{\max} of PtCl₆²⁻ is undoubtedly a ligand field effect caused by the ammonia molecules. The reason for the lack of luminescence in the two N-coordinated complexes is not clear and further work is being done in this area.

VII. Compounds of the d⁷ Metal Ion

The d⁷ configuration, where there is but one example of a metal which forms stable luminescent complexes, is still quite interesting because of the analogies of its spectroscopic states to the d⁸ configuration. With seven electrons (three holes) the high-spin complexes have a spin quartet (⁴T₁ in O_h and ⁴A₂ in T_d symmetries) ground state and quartet and doublet excited state manifolds. The energy levels and absorption spectra have been treated in some detail both theoretically^{169, 170} and experimentally.¹⁷⁰ The number of luminescence studies thus far completed with d⁷ metals is small, but it is hoped that further investigations will increase our understanding of both d⁷ and d⁸ metals. For example, d⁷ and d⁸ complexes should prove excellent partners for energy transfer studies. Because of the smaller values of 10Dq and B for Co(II) it should be possible to efficiently sensitize its infrared emission with certain Cr(III) complexes.

In contrast to d⁶ metals, only ionic d⁷ complexes are known to emit (CoF₂, O_h in the solid, may exist as CoF₄²⁻ in solution

(163) G. Blasse and A. Bril, *J. Electrochem. Soc.*, **114**, 1306 (1967).

(164) K. R. Wunschel, Jr., and W. E. Ohnesorge, *J. Amer. Chem. Soc.*, **89**, 2777 (1967).

(165) P. D. Fleischauer and G. Sartori, unpublished results.

(166) I. N. Douglas, J. V. Nicholas, and B. G. Wybourne, *J. Chem. Phys.*, **48**, 1415 (1968).

(167) G. B. Porter, private communication.

(168) There are discrepancies in the values of ref 165-167 which are probably due to slight variations in the crystals used.

(169) J. R. Perumareddi, *J. Phys. Chem.*, **71**, 3144, 3155 (1967).

(170) J. Ferguson, D. L. Wood, and K. Knox, *J. Chem. Phys.*, **39**, 881 (1963).

Table VIII
Absorption and Emission Spectral Maxima for d⁶ Metal Compounds

Compound	Absorption ^a		Emission ^{a-c}		Ref ^m
	Singlet state	Triplet state	Singlet state	Triplet state	
Ru(dipy) ₃ ²⁺	~22	18.5		17.25 (0.0059)	151, 153
Ru(py) ₂ (dipy) ₂ ²⁺	~21.2	?		~17.0 (0.005)	153, 154
Ru(CN) ₂ (dipy) ₂	~21.5	~18		~16.8 (0.004)	153, 154
Ru(en)(dipy) ₂ ²⁺	~19.5	~17.0		~14.6 (0.0007)	152-154
RuCl ₂ (dipy) ₂	~19.4	~16.5		~14.3 (0.0007)	152-154
Ru(ox)(dipy) ₂	~19.2	~16		~14.2 (0.0006)	152-154
Ru(tripy) ₂ ²⁺	21.16	18.1 (19.3)		16.67 (0.011)	141, 153, 154
Ru(<i>o</i> -phen) ₃ ²⁺	~22.2	~20		17.7 (0.0099)	151, 153, 154
Ru(ox)(<i>o</i> -phen) ₂	~19.5	~16.2		~14.4	153
Ru(5-CH ₃ - <i>o</i> -phen) ₃ ²⁺	22.2		17.3 ^{d,e}		150
Ru(4,4'-di(CH ₃)dipy) ₃ ²⁺	22.2		17.0 ^{d,e}		150
Ru(5,6-di(CH ₃)- <i>o</i> -phen) ₃ ²⁺	22.2		17.2 ^{d,e}		150
Ru(3,5,6,8-tetra(CH ₃)- <i>o</i> -phen) ₃ ²⁺	23.8		17.3 ^{d,e}		150
Os(dipy) ₃ ²⁺	20.5	16-17		~13.7	162a
Os(tripy) ₂ ²⁺	21.10	15-17		14.2 (<0.01)	141
Os(<i>o</i> -phen) ₃ ²⁺	20.5	16-18		13.8-14	162a
Ir(dipy) ₃ ³⁺	27.0	19.4 20.8		18.5	164
Ir(<i>o</i> -phen) ₃ ³⁺	26.6	21.9		~21.5	141
2,2'-dipy		23.0		18.5*	164*
<i>o</i> -phen				23.5	156
				22.213	157
ZnS:Fe ²⁺	3.0-4.5 ^f			2.4-3.0 ^f	140
RuCl ₂ (dpp) ₂	~22.7 ^g		~16.6 ^g		161
OsCl ₂ (dpp) ₂	27 ^h	~16.7 ⁱ 22.5 ⁱ	20.2 ^k		161
Co(CN) ₆ ³⁻	32.3*	18.5		14.4	146
				13.4* (0.68)	141*
Ru(CN) ₆ ⁴⁻		30-31		22.65 (31)	147
Co(SO ₃) ₂ (CN) ₄ ⁵⁻	26.5	17.0		14.3	139
Rh(aca) ₃	~31.25			24.20 (310)	162c
Rh(F ₆ -aca) ₃				21.23 (390)	162c
Rh(<i>o</i> -phen) ₃ ³⁺	28.4			22.3 (48.0)	162b
<i>cis</i> -Rh(<i>o</i> -phen) ₂ Cl ₂ ⁺	~26			13.0 (0.02)	162b
Al ₂ O ₃ :Rh ³⁺	25.40			14.6 (1.6)	163
Rh(py) ₂ Cl ₄ ⁻	23.2	20.0		15.15	139
Ir(py) ₂ Cl ₄ ⁻	23.6	19.6		15.6	139
IrCl ₃	18.5 ⁱ	11.9 ⁱ		~10	165
K ₂ PtCl ₆	28.3 (?)	22.1 (?)		14.5 (0.3-0.8)	5, 166
K ₂ PtBr ₆	23.0 (?)	19.0 (?)		13.51	5, 166
K ₂ SnCl ₆ :Pt ⁴⁺				14.50	166
Rb ₂ PtCl ₆				14.30	166
Cs ₂ PtCl ₆				13.99	166
(NH ₄) ₂ PtCl ₆				13.50	167
K ₂ Pt(SCN) ₆				13.70	167
Cs ₂ PtF ₆				15.00	167
[Pt(NH ₃) ₃ Cl ₃]Cl				17.00	165

^a Approximate values taken from graphs. All values in kK. ^b Lifetimes in msec given in parentheses. ^c Highest energy band maximum or shoulder (see text). ^d Values not corrected for photomultiplier sensitivity. ^e These values could be for phosphorescence (*i.e.*, ³π* → π). ^f Absorption and emission assigned to ⁵T₂-⁵E transition. ^g Absorption and emission assigned to ¹E_g-¹A_{1g} transition. ^h Estimated ¹E_g absorption. ⁱ Assigned to ³E_g absorption. ^j Assigned to ³A_{2g} absorption. ^k Assigned to ¹E_g emission. ^l Questionable assignment from reflectance spectrum. ^m Where values and references are marked with an asterisk it means that the marked value was taken from the marked reference.

but no emission data are known for the latter). For organizational purposes we have thus divided the material on these ionic complexes into two classes: tetrahedral and octahedral complexes.

A. TETRAHEDRAL COMPLEXES

In a tetrahedral ligand field the ordering of energy levels for d⁷ is the same as for d⁸ in an octahedral field: a ⁴A₂ ground state and accessible ⁴T₂, ⁴T₁, and ²E excited states. Therefore, one

would expect similar emission behavior (*i.e.*, either fluorescence, ⁴T₂ → ⁴A₂, phosphorescence, ²E → ⁴A₂, or both, depending on environment). The only reports of emission found were for Co²⁺ in ZnS, ZnSe, ZnTe, and CdS.¹⁷¹⁻¹⁷³ The articles

(171) K. K. Dubenskii, Ya. E. Kariss, A. I. Ryskin, P. P. Feofilov, and G. I. Khilko, *Opt. Spectrosc.*, **19**, 353 (1965).

(172) H. E. Gumlich and H. J. Schulz, *J. Phys. Chem. Solids*, **27**, 187 (1966).

(173) M. L. Reynolds and G. F. J. Garlick, *Infrared Phys.*, **7**, 151 (1967).

cited also contain references to other work done on these systems. These earlier studies are not treated here because the authors did not discuss the metal ion excited states.

Co(II) in ZnS has primary bands which are found at the same wavelengths in absorption and emission (2.85 and 3.14 μ) at 77°K. The longer wavelength band in absorption disappears as the temperature of the system is reduced to 5°K and is assigned as a "hot" band (*i.e.*, from the first excited vibrational level of the ground electronic state to the lowest level of the excited electronic state).^{171, 172} There is structure in the 2.85- μ emission band which is frozen out at 10°K.¹⁷¹ Fine structure is observed also on the long wavelength side of the 3.14- μ emission.¹⁷¹ This is due to phonon (vibronic) interaction or to splitting of the excited state. The excitation spectra of the emission have been measured at 5, 77, and 300°K and coincide with the absorption spectra.¹⁷² The emission is activated by absorption into $^4T_1(F)$, $^4T_1(P)$, $^2A_1(G)$, and $^2T_2(G)$ levels. Excitation in the ZnS lattice bands causes very weak Co²⁺ emission. On the basis of these observations the lowest energy spectral bands are assigned to the $^4T_2 \rightarrow ^4A_2$ transition.^{171, 172} One puzzling fact is the lifetime of the emission (4.75×10^{-4} sec) which is more indicative of phosphorescence than fluorescence.

B. OCTAHEDRAL COMPLEXES

Among the octahedral complexes of Co(II) only those with fluoride^{173, 174} and oxygen²⁸ coordinated ligands are known to luminesce. A high-spin d⁷ metal in an octahedral ligand field still has quartet and doublet spin states, but the ordering is reversed from tetrahedral d⁷ or octahedral d³. The ground state for d⁷ in O_h is $^4T_1(E)$. When Co²⁺ is doped into MgF₂ or ZnF₂ and irradiated in its $^4T_2(F)$, $^4T_1(P)$, or $^4A_2(F)$ absorption bands, a broad band emission from 6900 to 4500 cm⁻¹ is observed.¹⁷⁴ Sharp spikes which result from splitting of the ground state into six Kramers' doublets either by spin-orbit coupling or by reductions in the O_h symmetry are superposed on this band. The origin of the emission (6801 cm⁻¹) is at the same energy as the corresponding absorption band which is assigned as the $^4T_2 \leftarrow ^4T_1$ transition.

The most complete study²⁸ of a divalent cobalt complex involves MgO:Co²⁺. The absorption and emission spectra of the cobalt ion at three temperatures, 5, 18, and 77°K, are reported. Two types of emission were observed at 77°K: fluorescence ($^4T_2 \rightarrow ^4T_1(E)$), origin at 8151 cm⁻¹, and phosphorescence ($^2E \rightarrow ^4T_1(E)$), origin at 8045 cm⁻¹. When the system is cooled to 5°K only the latter emission is observed (see Figure 11) demonstrating that as in d³, the spin-allowed emission is thermally activated (E-type delayed fluorescence). If this is also true for the above-mentioned tetrahedral complexes it would explain the long fluorescence lifetime. However, the absence of any phosphorescence in those systems is strange since the cited lifetime must be the minimum doublet state lifetime, certainly long enough to permit phosphorescence. The separation of the 2E and 4T_2 states in Co(O)₆ is only 103 cm⁻¹, but this value is still greater than kT at liquid helium temperature. As opposed to the well studied Cr(III) lumino-phors which seldom show vibrational fine structure in fluorescence, this cobalt ion exhibits distinct structure on both bands with spacings of 170 and 230 cm⁻¹.

(174) L. F. Johnson, R. E. Dietz, and H. J. Guggenheim, *Appl. Phys. Lett.*, **5**, 21 (1964).

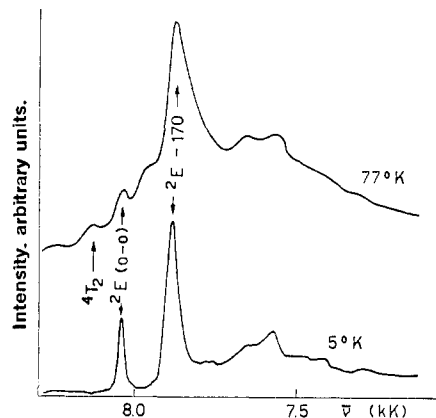

Figure 11. Emission spectra of MgO:Co²⁺ at 77° and 5°K (after ref 28).

Another report of the emission of Co²⁺ involves the study of solutions and crystals of chloride compounds.¹⁷⁵ CoCl₆⁴⁻ and Co(OH)₂²⁺ complex ions are involved, but as an emission requirement it is stated that there must be electron hole recombination. The significance of the crystal field splitting of the d⁷ configuration is discussed in connection with the luminescence, and references are given which concern other work of this nature on d⁷ and d⁸ systems. One Co(II) complex with oxinate (8-hydroxyquinolate) ligands luminesces probably as the result of a ligand localized transition.¹⁷⁶

VIII. Compounds of d⁸ Metal Ions

A significant amount of material has been published concerning the d⁸ configuration, and three metals with this electronic structure (Ni²⁺, Pd²⁺, and Pt²⁺) have been examined. Most of the literature concerns the emission of the Pt(CN)₄²⁻ ion although the results of studies of other Pt(II) complexes are beginning to be published. The d⁸ structure is certainly very interesting because complex geometries ranging from octahedral to linear are possible, and excited states vary accordingly. Ni(II) complexes are known to be octahedral, tetrahedral, linear (NiX₂), or square planar depending on the ligands, while those of Pt(II) are exclusively square planar.

Octahedral complexes in the strong field approximation have a ground state, $^3A_{2g}$, with $t_{2g}^6e_g^2$ configuration. Spin-allowed transitions to $^3T_{2g}$ and $^3T_{1g}$ levels, derived from the $t_{2g}^6e_g^3$ configuration, and spin-forbidden transitions to 1E_g and $^1A_{1g}$ (intraconfigurational $t_{2g}^6e_g^2$) may be observed in absorption. For the square planar geometry only two of the one-electron d orbitals (d_{xz} and d_{yz}) remain degenerate in energy. The actual ordering of the d levels is unresolved and may vary from one complex to another depending on the position of the ligand in the spectrochemical series.¹⁷⁷⁻¹⁸⁰ Because of this variation and because, for higher ligand field strengths, empty

(175) Ath. Trutia and A. Bohun, *Czech. J. Phys.*, **13**, 45 (1963); *Chem. Abstr.*, **59**, 4670e (1963).

(176) W. E. Ohnesorge and L. B. Rogers, *Spectrochim. Acta*, **15**, 27 (1959).

(177) A. I. Ryskin, A. M. Tkachuk, and N. A. Tolstoi, *Opt. Spectrosc.*, **17**, 390 (1964).

(178) C. Moncuit, *J. Phys. (Paris)*, **24**, 833 (1964).

(179) D. S. Martin, Jr., M. A. Tucker, and A. J. Kassman, *Inorg. Chem.*, **5**, 1298 (1966).

(180) W. R. Mason, III, and H. B. Gray, *J. Amer. Chem. Soc.*, **90**, 5721 (1968).

ligand π^* orbitals or the metal $6p_z$ orbitals may be lower in energy than the empty $d_{x^2-y^2}$ orbital, many different assignments of absorption and emission spectra have been proposed. The transitions involved are more questionable than those of $\text{Ru}(\text{dipy})_3^{2+}$ (see section VI.C) but should be easier to study because of the unique, characteristic properties of the d, p, and π levels. For the square planar complexes techniques such as magnetic circular dichroism¹⁸¹ and the measurement of spectra with plane polarized light¹⁸² have contributed to the knowledge of the energy levels and spectroscopic transitions. The study of emission of d^8 complexes has had limited success in helping to clarify the situation, but coupled with other methods should be productive in the future.

The information concerning d^8 metals has been divided simply into sections for each metal. The platinum section is then subdivided to include cyanide and other coordination complexes.

A. NICKEL(II)

The emission studies of Ni(II) involve compounds with tetrahedral and octahedral geometries in the solid state and the linear NiCl_2 molecule isolated in an argon matrix. NiF_3^- and NiF_2 , either as pure solids or in MgF_2 , MnF_2 , or ZnF_2 host crystals, are known to absorb and emit in the infrared region of the spectrum.^{173, 183} A crystal field theory interpretation of these emissions and of those of Ni^{2+} in ZnS , ZnSe , and ZnO has been given.¹⁷³ (Emission in ZnS was assigned to fluorescence, however, because of its lifetime, $\geq 10^{-4}$ sec; and because of the fact that the fluorescent level would not be the lowest spin-allowed excited level, we suggest that a better assignment would be phosphorescence, 1T_2 or ${}^1E(D) \rightarrow {}^3T_1(F)$.) At low temperatures in dilute and moderately concentrated crystals the 0-0 line was observed for ${}^3T_{2g} \rightarrow {}^3A_{2g}$ fluorescence in the fluoride complexes, while at higher Ni(II) concentrations splitting and shifting of the emission occurs which is due to apparent Ni-Ni interactions.¹⁸³

Ni(II) in an octahedral configuration in MgO is also known to emit both in the infrared²⁸ and in the visible.¹⁸⁴ In an account⁹ of the latter study it was suggested that the visible emission may be phosphorescence ${}^1T_{2g} \rightarrow {}^3A_{2g}$. Recognizing that this is an unusual assignment because it suggests that emission originates in the second excited state of a given spin multiplicity, the authors⁹ explain that the proposed luminescent state correlates to a different strong field configuration, $t_{2g}^5 e_g^3$, than the lowest excited state, which is $t_{2g}^6 e_g^2$. The interconfigurational radiationless transition would have a low probability but no lower, it would seem, than the analogous interconfigurational phosphorescence.

The infrared emission²⁸ of $\text{MgO}:\text{Ni}$ is composed of two lines at 77°K. These are assigned to transitions from the 3T_2 excited level, which is split by spin-orbit coupling into ${}^3T_2(T_2)$ and ${}^3T_2(E)$. Emission from the former, higher energy state results from a Boltzmann distribution of energy at 77°K and is frozen out at 4.2°K.

When NiCl_2 is isolated in an argon matrix at 4.2°K an in-

tense green fluorescence is observed.^{185, 186} The emission has three components, is very sharp and line-like, and shows vibrational structure with an average frequency of $360 \pm 5 \text{ cm}^{-1}$. If an axial symmetry field is assumed the emission is assigned¹⁸⁶ to transitions from the e_0 and e_0' levels of ${}^3P_{20+1} \rightarrow {}^3F$, both of which involve a number of vibrational levels of the ground state (*i.e.*, Stokes' shift).

B. PLATINUM(II)

1. Tetracyanide Complexes

The ordering of the energy levels in the $\text{Pt}(\text{CN})_4^{2-}$ ion both in solution and in crystals with various cations and crystal structures is not well understood even after extensive investigation. It is curious that the first report of emission¹⁸⁷ and the first somewhat detailed emission studies^{188, 189} appeared before any significant absorption data had been reported.^{176, 182} In one early publication luminescence decay times were determined for a large number of platinumocyanide crystals with different cations and different numbers of waters of crystallization.¹⁸⁸ The authors suggest that the "emission kinetics" depend on the cation and on the crystal structure. While this fact is probably true, Table IX shows that the measured decay times are not much different from 10^{-6} sec at low temperature and 10^{-7} sec at room temperature. Only with trivalent rare earth cations and large numbers of water molecules in the crystals do low-temperature decay times drop much below 10^{-6} sec.

Another early report concerns polarized emission from single crystals of Mg^{2+} and Ca^{2+} tetracyanoplatinate(II).¹⁸⁹ The emission at room temperature, polarized perpendicular to the z axis (in the paper, parallel to the plane of the complex), had a single maximum while that parallel to z had two maxima. For both salts the intensity of the in-plane emission was considerably greater than that which was z polarized. Also, it is evident that the wavelengths of the emission maxima (parallel or perpendicular) depend noticeably on the cation in the crystal.

A third preliminary investigation¹⁹⁰ of the Pt(II) cyanides also concerns lifetime determinations which in general agree with the earlier work.¹⁸⁸

Variations in wavelengths of absorption and emission maxima and in the shapes of emission bands for crystalline $\text{M}[\text{Pt}(\text{CN})_4] \cdot n\text{H}_2\text{O}$ with differing z axis interaction have been emphasized more recently.^{182, 191} Again different cations and, for a given cation, different amounts of water can affect the shape and the maxima of emission. For $\text{Mg}[\text{Pt}(\text{CN})_4] \cdot n\text{H}_2\text{O}$ two bands are present in emission, which depend on the water content of the crystal. The decay time varies depending on the wavelength of observation (this phenomenon is referred to as a "relaxation spectrum" and exists because of the presence of more than one luminescing center in the crystal) but not of

(185) D. E. Milligan, M. E. Jacox, and J. D. McKinley, *J. Chem. Phys.*, **42**, 902 (1965).

(186) D. M. Gruen, J. R. Clifton, and C. W. DeKock, *ibid.*, **48**, 1394 (1968).

(187) I. A. Khvostikov, *Tr. Gos. Optich. Inst. Leningrad*, **12**, 3 (1937); *Chem. Abstr.*, **32**, 2432^a (1938).

(188) N. A. Tolstoj, A. K. Trofimov, A. M. Tkachuk, and N. N. Tkachuk, *Bull. Acad. Sci. USSR, Phys. Ser.*, **20**, 529 (1956).

(189) C. Moncuit, *C. R. Acad. Sci., Paris*, **252**, 397 (1961).

(190) L. Brewer, C. G. James, R. C. Brewer, F. E. Stafford, R. A. Berg, and G. M. Rosenblatt, *Rev. Sci. Instrum.*, **33**, 1450 (1962).

(191) A. M. Tkachuk, *Izv. Akad. Nauk SSSR, Ser. Fiz.*, **27**, 670 (1963).

(181) A. J. McCaffery, P. N. Schatz, and P. J. Stephens, *J. Amer. Chem. Soc.*, **90**, 5730 (1968).

(182) C. Moncuit and H. Poulet, *J. Phys. Radium*, **23**, 353 (1962).

(183) R. E. Dietz, L. F. Johnson, and H. J. Guggenheim, *Phys. Quantum Electron. Conf. Proc.*, **361** (1966); *Chem. Abstr.*, **67**, 16407g (1967).

(184) F. A. Kröger, H. J. Vink, and J. v. d. Boomgaard, *Physica*, **18**, 77 (1952).

activation.¹⁹¹ Medium effects on the emission are discussed qualitatively, but the transition involved is not identified.

The absorption and emission of $\text{Pt}(\text{CN})_4^{2-}$ in aqueous solution, both liquid¹⁹² and frozen,^{191, 193, 194} have been treated. The characteristics of the luminescence of frozen solutions depend on the concentration of the complex¹⁹³ and on the rate of freezing.¹⁹¹ At very low concentrations ($\leq 10^{-5} M$) the same emission is obtained for all cations. At high concentration ($>10^{-3} M$) the emission resembles that of crystals with maximum hydration. In the former the luminophors are probably monomers or dimers of the acid $\text{H}_2[\text{Pt}(\text{CN})_4]$, since it is possible to replace Ba^{2+} with H^+ and not change the spectrum. There is no discussion of the transition involved in emission, nor is there any treatment of the concentration effects, although it seems likely that one contribution is from Pt-Pt interactions.

Freezing complex solutions into porous glasses of different pore sizes produces the same effects as varying the complex concentration.¹⁹⁴ With very small pore sizes the emission is typical of the monomer emission from dilute frozen solutions, while with larger pores the emission changes to that of the concentrated solutions.

Two polarization studies already have been mentioned.^{182, 189} A third one essentially verifies the previous results but for a larger number of complexes.¹⁹⁵ The polarization of absorption and emission spectra has been determined at room temperature, but the results do not seem to agree with the band assignments.¹⁸² The emissions of the Ca^{2+} and Ba^{2+} salts are more intense than the Mg^{2+} emission by a factor of 100, and the component perpendicular to the molecular z axis (in-plane) is the most intense in the polarization spectra. This does not agree with the assignment of the emission as $6p_z \rightarrow 5d_{z^2}$, since this transition should have little or no component in the x,y plane. In addition the cited transition is electric dipole allowed and does not require a vibronic mechanism. (The peak intensity of the analogous absorption increases as the temperature of the system is decreased.) Indeed, the multiple peak nature of the emissions suggests more than one transition involving closely spaced upper ($6p_z$ and π^*) or lower (d_{z^2} , d_{xy} , $d_{xz,yz}$) levels or, again, more than one emitting center in the lattice. Further polarization and MCD studies at low temperatures should solve this dilemma.

Considerable research has been devoted to the concept of the "relaxation spectra" (*vide supra*)^{188, 191, 196-199} of $\text{Pt}(\text{CN})_4^{2-}$. The experimental decay times ($\tau = 10^{-6}$ - 10^{-7} sec) are in the phosphorescence range for a heavy metal such as platinum, but the existence of spin triplet states has never received serious consideration for this complex. (Only in one instance where a peak in the excitation spectrum was observed in a region where no absorption is known has the possibility of spin-forbidden transitions been considered.¹⁹²) The temperature function of

τ , rather than τ itself, depends somewhat on the counterion of the dinegative complex and on the water content of the crystals. τ of $\text{Mg}[\text{Pt}(\text{CN})_4] \cdot 7\text{H}_2\text{O}$, which is constant at all wavelengths, shows an Arrhenius dependence with temperature.¹⁹¹ A break in the curve of τ vs. T^{-1} occurs at $T^{-1} = 8 \times 10^{-3} \text{ deg}^{-1}$ (125°K), which may correspond to a change in crystal structure. (Unfortunately the structure information is not available.) For other complexes curved lines (τ vs. T^{-1}) are obtained and τ varies with emission wavelength. Both of these observations result from the presence of more than one luminescing center.¹⁹⁸ A final study concerning lifetime measurements deals with the bimolecular quenching of $\text{Pt}(\text{CN})_4^{2-}$ emission.²⁰⁰

The spectra of $\text{Pt}(\text{CN})_4^{2-}$ crystals differ greatly from the solution spectra both in absorption and emission. At least three interpretations have been applied to the solution spectra,^{180, 182, 201} the latest¹⁸⁰ of which is represented in Figure 12. The relative energies of the lowest, four one-electron d orbitals and the energies of the ligand π^* , metal $6p_z$ and $d_{x^2-y^2}$ orbitals are in dispute. In the most recent interpretation of the solution spectra, which includes low-temperature absorption, but not emission, of glasses, the three lowest energy absorption bands (see Figure 13) are assigned to charge transfers from three different sets of d orbitals (d_{xy} , $d_{xz,yz}$, and d_{z^2}) to the ligand $\pi^*(3p_z)$ orbital.¹⁸⁰ One of these transitions ($\pi^* \leftarrow d_{xy}$; ${}^1\text{B}_{1u} \leftarrow {}^1\text{A}_{1g}$) is symmetry forbidden and has a lower intensity than $\pi^* \leftarrow d_{xz,yz}$ (${}^1\text{E}_u \leftarrow {}^1\text{A}_{1g}$). However, $\pi^* \leftarrow d_{z^2}$ (${}^1\text{A}_{2u} \leftarrow {}^1\text{A}_{1g}$) is an allowed transition but has an intensity comparable to ${}^1\text{B}_{1u} \leftarrow {}^1\text{A}_{1g}$.

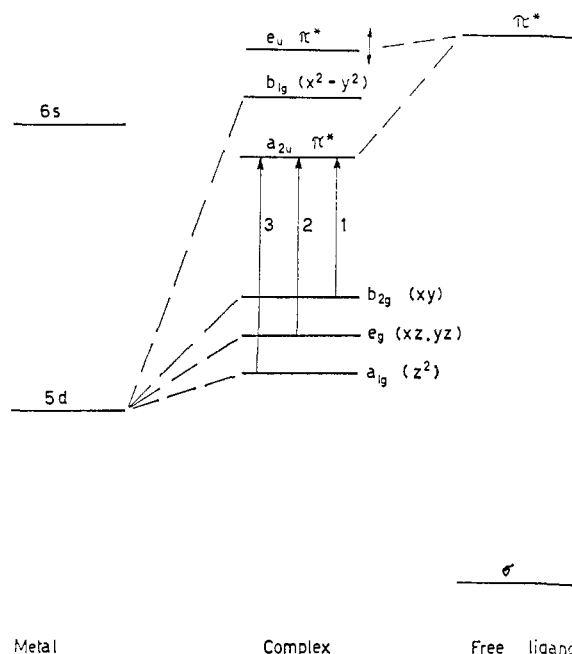

Figure 12. Schematic energy level diagram for $\text{Pt}(\text{CN})_4^{2-}$ (after ref 180).

In other interpretations,^{182, 201} based on the absorption spectra at room temperature and comparison with the crystal

(192) L. Ancarani Rossiello and C. Furlani, *Atti Accad. Naz. Lincei, Rend., Classe Sci. Fis., Mat. Nat.*, **38**, 207 (1965); *Chem. Abstr.*, **65**, 1619c (1966).

(193) A. M. Tkachuk and N. A. Tolstoi, *Opt. Spectrosc.*, **20**, 570 (1966).

(194) N. A. Tolstoi and A. M. Tkachuk, *ibid.*, **21**, 310 (1966).

(195) M. L. Moreau-Colin, *Bull. Soc. Roy. Sci. Liege*, **34**, 778 (1965); *Chem. Abstr.*, **64**, 18721h (1966).

(196) N. A. Tolstoi, *Dokl. Akad. Nauk SSSR*, **102**, 935 (1955); *Chem. Abstr.*, **50**, 8332a (1956).

(197) N. A. Tolstoi, *J. Phys. Radium*, **17**, 801 (1956).

(198) A. I. Ryskin, A. M. Tkachuk, and N. A. Tolstoi, *Opt. Spectrosc.*, **21**, 31 (1966).

(199) N. A. Tolstoi and A. P. Abramov, *ibid.*, **22**, 272 (1967).

(200) N. A. Tolstoi, A. M. Tkachuk, and L. E. Ageeva, *ibid.*, **14**, 85 (1963).

(201) A. I. Ryskin, A. M. Tkachuk, and N. A. Tolstoi, *ibid.*, **17**, 304 (1964).

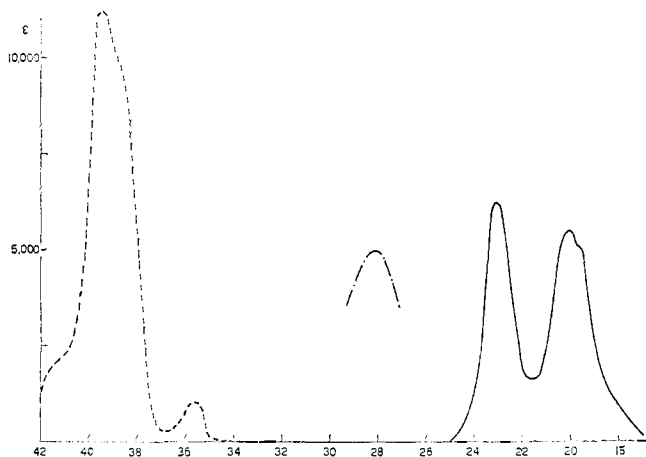
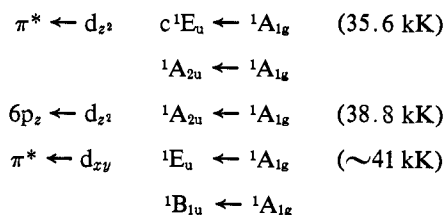

Figure 13. Absorption (---) (after ref 178) and emission (—, intensity arbitrary units) (after ref 193) of $\text{Pt}(\text{CN})_4^{2-}$ in aqueous solution. Also included is a suggested 192 excitation spectrum maximum (— · —) in arbitrary units.

spectra, the metal d_{z^2} is placed above d_{xy} and d_{xz}, yz , the three ligand π^* orbitals are considered degenerate, and the metal $6p_z$ orbital is placed below $d_{x^2-y^2}$. The result is that the three lowest energy transitions are assigned as follows.



While this assignment fits the available polarization data for the solid it does not explain the splitting of the ~ 38 -kK band at low temperature, nor does it fit the intensity variations of the three bands.

The lowest energy absorption of $\text{Pt}(\text{CN})_4^{2-}$ is separated from the highest energy emission ($\bar{\nu}_{\text{max}} = 23.0 \text{ kK}$) in solution¹⁹³ by 12.6 kK. Even if the bands are quite broad it is not likely that they overlap. This means the same excited state cannot be involved in both bands and that a level lower than 35.6 kK probably exists. Some evidence for a band near 28 kK was found¹⁹² in the activation spectrum, which may be an S_0 - T_1 transition corresponding to the 35.6-kK S_0 - S_1 (*vide supra*).

In the solid state the cations of the $\text{M}[\text{Pt}(\text{CN})_4] \cdot n\text{H}_2\text{O}$ complex are located along the z molecular axis and stabilize an electron in an orbital directed along this axis relative to the same complex in solution.¹⁷⁷ As evidence of this conclusion a "new," longer wavelength absorption (actually composed of two bands), which is very cation sensitive, is observed in the crystal spectra.^{177, 178, 182} A second band in crystal spectra located at about 38 kK is much less sensitive to the counterion.^{177, 178} The ordering of the d levels in the crystals is again uncertain. The triplet excited states from which emission probably originates may have a different ordering than the corresponding singlets.

2. Other Ligands

Fortunately the energy level ordering schemes for other Pt(II) complexes, which have been observed to emit visible radiation,

are more simple than for the cyanides by virtue of the fact that the ligand field strengths of the other ligands are smaller, and they have no low-energy empty π orbitals. A series of ethanolamine (and diethanolamine) dihalide Pt(II) complexes has been investigated both in absorption and emission.^{202, 203} These ligands occupy a much lower position in the spectrochemical series than CN^- . Both singlet and triplet d - d transitions were observed and assigned in the absorption spectra.²⁰³ For all complexes a weak absorption band was assigned to the ${}^8E_g \leftarrow {}^1A_{1g}$ transition. A single peak broad band emission was assigned to the reverse of the above transition, ${}^8E_g \rightarrow {}^1A_{1g}$. This assignment seems questionable on the basis of the reported data for the following reasons: (1) the ${}^1E_g \leftarrow {}^1A_{1g}$ is not the lowest energy singlet transition assigned; (2) the emission and absorption maxima assigned to ${}^8E_g \leftarrow {}^1A_{1g}$ are separated by 9.0–11.0 kK, depending on the complex; and (3) weak absorption bands at lower energy than ${}^8E_g \leftarrow {}^1A_{1g}$ are observed for some complexes but not assigned.

The energy levels of $\text{K}_2[\text{PtCl}_4]$ have been studied extensively and are much better understood.^{179–181} Recently,²⁰⁴ the solid has been found to emit with a broad band (half-width $\sim 2.4 \text{ kK}$) and a maximum at $\sim 12.7 \text{ kK}$. There was some indication of fine structure in the emission but it is not possible to assign it at the present time. From previous experiments on the absorption spectrum the ordering of the triplet levels was not certain. A sharp reduction in the emission intensity, observed when the direction of polarization of the exciting light in the lowest energy absorption band is changed by 90° , suggests a unique polarization of both absorption and emission. If spin-orbit coupling is neglected the only transition consistent with this polarization²⁰⁴ is ${}^3A_{2g} \leftarrow {}^1A_{1g}$ ($d_{x^2-y^2} \leftarrow d_{xy}$). This is also the lowest assigned singlet transition and therefore seems to be a reasonable assignment for the phosphorescence. (We note that for PtCl_4^{2-} the d orbital energies are $d_{x^2-y^2} \gg d_{xy} > d_{xz}, yz > d_{z^2}$, a situation somewhat different from that proposed for $\text{Pt}(\text{CN})_4^{2-}$.)

Among other Pt(II) complexes a thiourea adduct in solution has been reported to luminesce and was used for analytical purposes.²⁰⁵ Also the red and yellow forms of $[\text{Pt}(\text{dipy})\text{Cl}_2]$ are known to emit when excited with near-ultraviolet light.^{206, 207} In a later study the $\text{Pt}(\text{dipy})_2^{2+}$, $\text{Pt}(o\text{-phen})_2^{2+}$, and $[\text{Pt}(o\text{-phen})\text{Cl}_2]$ compounds were also investigated.²⁰⁴ These complexes of organic heterocyclic ligands have very interesting absorption and emission spectra. In the solid state the luminescence is broad and structureless. On the contrary, when $[\text{Pt}(\text{dipy})\text{Cl}_2]$ (yellow form) is dissolved in methanol and frozen into a rigid glass a four peaked emission similar to that of $\text{Ru}(\text{dipy})_3^{2+}$ is observed. The spacing of the peaks is $\sim 1300 \text{ cm}^{-1}$ as with ruthenium. This emission may be charge transfer in nature resulting from a crossing of the lowest energy excited state in going from solid to solution.

$[\text{Pt}(\text{gly})_2]$ has been found to luminesce in the solid and in methanol solution at room temperature.²⁰⁴ This complex exists in *cis* and *trans* isomers, and the *cis*, but not the *trans*,

(202) A. M. Tkachuk and N. A. Tolstoi, *Opt. Spectrosc.*, **9**, 136 (1960).

(203) A. I. Ryskin, A. M. Tkachuk, and N. A. Tolstoi, *ibid.*, **18**, 238 (1965).

(204) D. L. Webb and L. Ancarani Rossiello, private communication.

(205) L. G. Polyitsyna and K. P. Stolyarov, *Vestn. Leningrad. Univ., Ser. Fiz. Khim.*, **19**, 136 (1964); *Chem. Abstr.*, **62**, 11148a (1965).

(206) J. T. Randall, *Nature*, **142**, 113 (1938).

(207) L. Ancarani Rossiello and C. Furlani, *Ric. Sci.*, **35**, 1416 (1965).

undergoes a unimolecular photochemical isomerization.²⁰⁸ The possibility that the *trans* isomer may be the luminophor suggests that [Pt(gly)₂] represents a unique system in which one isomer is photosensitive while the other is photoluminescent.

IX. Compounds of d¹⁰ Metal Ions

It may be argued that the d¹⁰ metals are not part of the transition series, but rather closed shell group II metals. Indeed, the ground states of these metals have properties similar to those of calcium, strontium, etc., but the excited states of interest in emission studies are d⁹ configuration and thus may have transition metal properties. Accordingly, the reports of emission studies are divided into two sections: those primarily concerned with analytical procedures, where the emission is localized on the ligand and is perturbed by the closed shell metal; and those involving copper, silver, and gold complexes, where the emission corresponds to a transition of an electron from a metal 4p to a 3d orbital.

A review has been published recently which summarizes the analytical uses of fluorescing metal chelate complexes.²⁰⁹ There is no treatment of the electronic transitions involved in luminescence (hence the use of fluorescence may be a misnomer); however, it is probable that they concern ligand localized states. (See also ref 25.) The mono- or bis(8-hydroxyquinoline-5-sulfonic acid) zinc complex luminesces strongly in solution at pH greater than 5, but the emission is quenched by the unfilled d orbital metals Cu(II)²¹⁰ and Pd(II).²¹¹ The latter reference is the most recent in a series devoted to fluorescing chelates in analysis. The luminescence of the 8-(*p*-tosylamino)quinoline complex of Zn(II) has been used²¹² to detect very small quantities of that metal in GeCl₄ and HSiCl₃. Zn(II) and Cd(II) form fluorescing chelates with 8-mercaptoquinoline.²¹³ The free ligand is believed to emit from the second excited singlet state, which is ~13 kK above the lowest excited singlet,²¹³ but there is no statement as to the origin of complex emission which is ~6.3 kK to the red of that of the free ligand.

The emission of Cu(I) compounds has been investigated⁷ in the solid state and in solution. Cu⁺ is tetrahedrally coordinated in ZnS and exhibits both visible (green) and infrared emission.²¹⁴ A model involving transitions from the conduction band of the solid to the d shell of Cu²⁺ was proposed to explain the emission. The emission of copper halides and of the halides of silver, gold, thallium, lead, and other metals is well known,²¹ but not applicable to this review. At least one study has been reported concerning Cu⁺ in HCl and HBr solutions.²¹⁵ The emission is observed only at low temperatures (~140°K) and definitely involves Cu⁺ and not Cu²⁺. As Cu⁺ reacts photochemically to product Cu²⁺ the emission intensity is reduced. The behavior is compared with that of the solid compounds (CuCl and CuBr) and the transition responsible is assigned

(208) F. Scandola, O. Traverso, V. Balzani, G. L. Zucchini, and V. Carassiti, *Inorg. Chim. Acta*, **1**, 76 (1967).

(209) C. E. White in "Fluorescence," G. G. Guilbault, Ed., Marcel Dekker, Inc., New York, N. Y., 1967, p 275.

(210) R. E. Ballard, *J. Chem. Soc.*, 2084 (1965).

(211) J. A. Bishop, *Anal. Chim. Acta*, **39**, 189 (1967).

(212) G. V. Serebryakova and E. A. Bozhevol'nov, *Metody Analiza Khim. Reaktivov Preparatov*, **11**, 89 (1965); *Chem. Abstr.*, **65**, 1381a (1966).

(213) P. D. Anderson and D. M. Hercules, *Anal. Chem.*, **38**, 1702 (1966).

(214) J. L. Birman, *Phys. Rev.*, **121**, 144 (1961).

(215) M. U. Belyi and P. I. Krivenko, *Ukr. Fiz. Zh.*, **10**, 420 (1965); *Chem. Abstr.*, **63**, 6495g (1965).

Table IX

Absorption and Emission Spectral Maxima for d⁸ Metal Compounds

Compound	Absorption ^a	Emission ^{a,b}	Ref
Ni ²⁺ in ZnS ^a	5.30 (⁸ T ₂) 8.50 (¹ T ₂) 9.40 (³ A ₂)	8.00 ^d (≥100)	173
ZnSe ^c	4.8 (⁸ T ₂) 9.0 (³ A ₂)	4.0 (<10)	173
KMgF ₃ ^c	7.8 (⁸ T ₂) 13.7 (⁸ T ₁)	6.0 (>10 ⁸)	173
ZnF ₂ ^c	4.5 (⁸ T ₂) 8.4 (⁸ T ₁) 13.5 (¹ E ₁)	5.5	173
MgO ^c	8.002 8.179	8.002 8.179	28 28
NiCl ₂	21–24	21 (?) 17.2–17.0 19.6–18.9 21.3–20.4	184 186 186 186
Pd(CN) ₄ ²⁻		22.7	192
Pt(CN) ₄ ²⁻	28 ^e 38	24.4 ^f 18.1 ^f 23.0 19.5	192 192 193 193
M[Pt(CN) ₄] _x ·xH ₂ O M = Li ₂ x = ?	20.6 22.3	20 (1.0)	177, 188, 198
Na ₂	3	23.5 (0.85)	188
Na ₂	0	19.6 (1.0)	188
K ₂	3	20.6 (0.95)	188
K ₂	0	20.0 (0.6)	188
Rb ₂	?	21.5 (0.85)	188
Cs ₂	?	21.8	188
Mg	7	18 19.4	17.21 ^f (0.15) 182, 189 191
Mg	5	19.5 (0.69)	191
Mg	4	19.2 (0.8– 0.95)	191
Mg	2	19.5 (0.07)	191
Mg	0	17.0 (0.4)	198
Ca	5	23.9 37.9	21.46 (0.6– 0.8) 182, 188 189
Ca	0	21.6 (0.9)	188
Sr	5	28.3 37.5	?(1.25) 182, 188
Ba	4	20.3 22.7 25.4	20.0 (0.6– 0.9) 177, 182 188
Yb ₂ [Pt(CN) ₄] ₃ ·21H ₂ O	16.8 19.6	?(<0.1)	188
Pr ₂ [Pt(CN) ₄] ₃ ·18H ₂ O		?(0.1)	188
Sm ₂ [Pt(CN) ₄] ₃ ·18H ₂ O		?(0.3)	177, 188
<i>trans</i> -[Pt(etm) ₂ I ₂]	24.7	~15.2	203
<i>cis</i> -[Pt(etm) ₂ I ₂]	24.4	~15.1	203
<i>trans</i> -[Pt(etm) ₂ Br ₂]	25.9	~15.9	203
<i>cis</i> -[Pt(etm) ₂ Br ₂]	26.8	~15.9	203
<i>trans</i> -[Pt(etm) ₂ Cl ₂]	26.8	~15.3	203
<i>cis</i> -[Pt(etm) ₂ Cl ₂]	27.9	~16.6	203
<i>trans</i> -[Pt(detm) ₂ I ₂]		~15.5	203
<i>trans</i> -[Pt(detm) ₂ Br ₂]		~16.0	203
<i>trans</i> -[Pt(detm) ₂ Cl ₂]		~14.0	203
K ₂ PtCl ₄	18, 20 24, 26	12.7	204

^a For assignment see text, section VIII. All values in kK. ^b Decay times (μsec) in parentheses. When not indicated, temperature is 77–120°K. ^c Note that ZnS and ZnSe are tetrahedral, and the fluoride and MgO are octahedral. ^d See text for explanation. ^e Approximate, from excitation spectrum. ^f Temperature is 293°K.

to the reverse of the $3d^9 4p \leftarrow 3d^{10}$ absorption (*i.e.*, $^1P_1 \rightarrow ^1S_0$ or $^3D_1 \rightarrow ^1S_0$). A similar conclusion has been reached for Cu^+ , Ag^+ , and Au^+ emissions in potassium and sodium halides.²¹⁶

When a benzoin-copper complex in ammonium hydroxide-ethanol mixed solvent is irradiated with near-ultraviolet light, a blue emission is observed.²¹⁷ A final example of Cu^+ emission is reported in an energy-transfer study involving Cu^+ and Tb^{3+} in $Sr^{2+}-Mg^{2+}-PO_4^{3-}$ glass.²¹⁸ Cu^+ produces a broad band emission with a maximum at 20.4 kK. Tb^{3+} , on the other hand, exhibits sharp line-like emission with maxima at 20.4, 18.3, 17.2, and 16.0 kK. If the concentration of Tb^{3+} is increased while Cu^+ is kept constant, the band emission decreases in favor of the line spectrum. When only Tb^{3+} is present in the glass, its emission is very weak if excited with 254-m μ wavelength light; but if Cu^+ is also present, the Tb^{3+} emission is strong under the same excitation.

Table X
Absorption and Emission Spectral Maxima of d^{10}
Metal Compounds

Compound	Absorption, kK	Assignment	Emission, kK	Ref
Zn(5-SO ₃ H-hq) _{1.2}	27-28	Ligand transition	19	210
Zn(hq-S) _n		?	18.7	213
Cd(hq-S) _n		?	18.6	213
ZnS:Cu ⁺		Conduction band → T ₂ (d)	19.16	214
		T ₂ → E	5.98	214
			6.45	214
Cu ⁺ -benzoin in NH ₄ OH-EtOH		Ligand transition	23.26	215
			21.74	215
Sr _{2.5} Mg _{0.3} (PO ₄) ₂ : Cu ⁺	40	3d ⁹ 4p → 3d ¹⁰	20.41	217

X. Concluding Remarks

We have made an attempt to collect all of the available data on the emission spectroscopy of transition metal coordination compounds, especially those of the molecular (nonlabile) type. In many instances we have reiterated major points of the discussion and interpretation of these data and at times added our own opinions or conclusions. Of the 11 (d^0-d^{10}) possibilities of d electronic number, examples from eight are known to luminesce. Notably absent are compounds of d^1 , d^4 , and d^9 metals. Compounds of Ti(III), V(IV), Cr(V), Mo(V), and W(V) have d^1 structures. The absorption spectra of many of them are known.⁸ Only a complex of VO²⁺ has been reported luminescent, but the luminophor is a complicated structure probably involving polymeric species.²¹⁹ Complexes with d^4 structure include those of Cr(II) and Mn(III). Many complexes of the former are known, and although easily oxidized in solution, they can be quite stable in the solid. Luminescence studies are desirable since they can be performed on solid samples. $Cu(II)$ is the only d^9 ion whose absorption spectra are known to us. The situation regarding luminescence of this

ion is confused and results are currently believed^{21, 215} to be due to Cu^+ rather than Cu^{2+} .

The expansion of this area of research in the last decade has been extraordinary. The results of luminescence research have enabled more accurate assignments of electronic energy levels, more precise calculation of ligand field parameters ($10Dq$, B , and C , etc.), better assessment of σ and π bonding in complexes, and accurate evaluation of the probabilities of excited state processes. Coordination compounds provide some noteworthy comparisons to the widely studied organic molecules. Electronic transitions in the former usually are not localized in a single bond as they often are for many organic molecules (carbonyls, olefins, etc.). Ground-state spin multiplicities are often greater than one. And, little work has been performed in the area of oxygen quenching of metal ion emission; when looked for, no effects were found. Many compounds have been explored but many remain, and much work is needed to fully understand the questions suggested by preliminary results.

Acknowledgments. The authors thank Dr. D. L. Webb for his extensive assistance in the preparation of the manuscript, especially in the section concerning d^8 metals; and Professor G. Sartori for reading the manuscript, and for his hospitality during our stay in his institute. We also wish to thank Professor J. O. Edwards (Brown University) for helping in the formulation of the original proposal of this review. Finally, thanks are due to Professors L. S. Forster, G. B. Porter, H. L. Schlaefer, and G. A. Crosby for providing us with preprints of manuscripts for publication. The preparation of this manuscript was made possible by the support of a joint contract between the U. S. National Science Foundation (GP-5725) and the National Research Council of Italy.

XI. Appendix

The abbreviations used for coordinated ligands are as follows.

Abbreviation	Definition
aca	acetylacetonate (2,4-pentanedione uninegative ion)
Br-aca	3-bromoacetylacetonate
Cl-aca	3-chloroacetylacetonate
I-aca	3-iodoacetylacetonate
NO ₂ -aca	3-nitroacetylacetonate
CH ₃ -aca	3-methylacetylacetonate
C ₂ H ₅ -aca	3-ethylacetylacetonate
F ₃ -aca	1,1,1-trifluoroacetylacetonate
F ₆ -aca	1,1,1,5,5,5-hexafluoroacetylacetonate
acet	acetamide
antip	antipyrene
bza	benzoylacetate (1-phenyl-1,3-butanedione anion)
dbm	dibenzoylmethide (1,3-diphenyl-1,3-propanedione anion)
detm	diethanolamine
dipy	2,2'-dipyridine
4,4'-di(CH ₃)-dipy	4,4'-dimethyl-2,2'-dipyridine
dma	N,N'-dimethylacetamide
dmf	N,N'-dimethylformamide
dpp	1,2-bis(diphenylphosphino)ethane
dsc	diethyldiselenocarbamate, (C ₂ H ₅) ₂ NCS ₂ ⁻
dsp	diselenophosphate
dtb	dithiobenzoate
dte	diethyldithiocarbamate, (C ₂ H ₅) ₂ NCS ₂ ⁻
dtoc	dithiooxalate
dtp	dithiophosphate
dtpa	dithiophenylacetate
dtpi	dithiophosphinate
en	ethylenediamine

(216) N. E. Lushchik and S. G. Zazubovich, *Tr. Inst. Fiz. Astron., Akad. Nauk Est. SSR*, 141 (1961); *Chem. Abstr.*, 56, 12423g (1962).

(217) K. P. Stolyarov and A. V. Drobachenko, *Vestn. Leningrad. Univ., Ser. Fiz. Khim.*, 20, 120 (1965); *Chem. Abstr.*, 63, 7641d (1965).

(218) H. Mizuno and M. Masuda, *Bull. Chem. Soc. Jap.*, 37, 1239 (1964).

(219) D. Eastwood and M. Gouterman, *J. Mol. Spectrosc.*, 23, 210 (1967); 25, 547 (1968).

<i>Abbreviation</i>	<i>Definition</i>	<i>Abbreviation</i>	<i>Definition</i>
etm	ethanolamine	<i>o</i> -phen	<i>o</i> -phenanthroline
form	1,3-butanedione anion	5,6-di(CH ₃)- <i>o</i> -phen	5,6-dimethyl- <i>o</i> -phenanthroline
GASD	C(NH ₂) ₃ Al(SO ₄) ₂ ·6D ₂ O:Cr ³⁺	3,5,6,8-tetra-	
GASH	C(NH ₂) ₃ Al(SO ₄) ₂ ·6H ₂ O:Cr ³⁺	(CH ₃)- <i>o</i> -phen	3,5,6,8-tetramethyl- <i>o</i> -phenanthroline
gly	glycinate	ox	oxalate
hq	oxinate = 8-hydroxyquinolate	py	pyridine
hq-S	8-mercaptoquinoline	Sexant	ethyl selenoxanthate (C ₂ H ₅ OCS ₂ ⁻)
2-CH ₃ -hq	2-methyl-8-hydroxyquinolate	tgl	thioglycolate (CH ₂ OHCS ₂ ⁻)
5,7-diBr-hq	5,7-dibromo-8-hydroxyquinolate	tn	diethylenetriamine
5-SO ₃ H-hq	8-hydroxyquinoline-5-sulfonic acid	tpp	triphenylphosphine
imid	imidazolidone	tripy	2,2',2''-tripyridine
mal	malonate (<i>i.e.</i> , anion of malonic acid)	tu	thiourea
malon	1,3-propanedione anion	xant	ethyl xanthate (C ₂ H ₅ OCS ₂ ⁻)