

IR-Laser Photochemistry

DONALD W. LUPO[†] and MARTIN QUACK*

Laboratorium für Physikalische Chemie der ETH-Zürich, ETH-Zentrum, CH-8092 Zürich, Switzerland

Received June 13, 1986 (Revised Manuscript Received September 17, 1986)

Contents

1. Introduction	181
2. Theoretical Foundations of IR-Multiphoton Excitation and IR Photochemistry	183
2.1. Quantum Theory of the Excitation of a Quantized Molecular System by a Coherent Classical Radiation Field	183
2.2. The Choice of a Basis: Spectroscopic States	184
2.3. The Quasiresonant and Floquet Approximations	185
2.4. Statistical Mechanical Concepts	185
2.5. Summary of the Photophysical Primary Processes of Infrared Multiphoton Excitation and Their Nomenclature	186
2.6. Chemical Primary Processes: Specific Rate Constants and Product Energy Distribution in Chemical Reactions	187
2.7. Solutions of the Master Equations and Coarse-Grained Rate Parameters	188
3. Qualitative Experiments in IR Photochemistry	190
3.1. Isotope Separation Using Infrared Lasers	191
3.2. Visible and UV Luminescence after IR-Multiphoton Absorption	194
3.3. IR Photochemistry of Ions	195
3.4. IR Photochemical Production of Radicals	195
3.5. The Chromophore Principle and Mode-Selective IR Photochemistry	196
4. Quantitative IR Photochemistry	199
4.1. Determination of Relative Rates: Translational Energy and Internal State Distributions	199
4.2. Determination of Absolute Yields and Rate Coefficients for IR Photochemistry	204
4.3. Estimation of Absolute Rate Coefficients	208
4.4. Radiative and Collisional Energy Transfer as Investigated by the Measurement of Internal-State Distributions	209
5. Special Experimental Advances in IR-Laser Chemistry	210
6. Concluding Remarks and Outlook	212

1. Introduction

The idea of using infrared lasers to induce chemical reactions led to early experiments shortly after the development of the CO₂ laser.¹⁻³ The interpretation of

these early experiments was still uncertain as to contributions from collisional, possibly nonthermal heating, plasma chemistry due to laser induced breakdown, and other complications. However, after the discovery of isotope separation by unimolecular reactions induced by infrared lasers,^{4,5} the proof of collisionless infrared multiphoton excitation and dissociation of polyatomic molecules in molecular beams,⁶⁻⁹ and the development of a general theoretical framework in the context of unimolecular rate theory,¹⁰ IR-laser chemistry is nowadays a mature branch of chemical reaction dynamics and kinetics.

We know now that this *vibrational photochemistry* of polyatomic molecules is a universal phenomenon. It occurs easily upon irradiation of a strong vibrational absorption band with sufficiently intense, pulsed laser light, even though in most cases many (10 to 40) infrared photons are needed to reach the energy threshold for the reaction. For the larger polyatomic molecules, it even seems likely that a rough estimate of the IR-photochemical reaction rate is possible, based upon a few easily accessible spectroscopic and thermochemical properties of the reactant molecule.^{11,12,13} For triatomic and other small molecular systems, rather complete quantum theoretical treatments are emerging, which include detailed molecular properties from high-resolution rovibronic spectroscopy.¹⁴ Among the numerous potential applications of IR-laser chemistry, isotope separation has been discussed most often, but other applications have been established as well and proposals have been made repeatedly concerning the very special properties of the hypothetical mode selectivity with infrared excitation.

Unlike UV-vis laser excitation, which gives rise to phenomena often but not always similar to photochemistry with ordinary sunlight, efficient IR-multiphoton excitation is virtually impossible without lasers, at least in "typical" cases. The great excitement which arose from this new and unprecedented laser chemistry resulted in a large number of short and long, sometimes popular reviews over the last decade. Early reviews can be found in ref 15-19. Most of the material presented there would presumably have to be presented differently today in view of our progress in understanding the mechanism of IR photochemistry. The work of specific research groups is rather completely contained in the book by Grunwald and co-workers,¹⁷ the articles from the Berkeley groups,^{20,21} from the SRI group,²² from Reisler and Wittig,²³ who discuss also multiphoton ionization, and in Letokhov's book,²⁴ which covers from the point of view of its author much of the considerable work in the field carried out in the Soviet Union (see also ref 25). Each of these reviews covers quite well the work of the particular research groups mentioned. Of the more recent general reviews²⁶⁻³³ one may mention in particular the one by Ashfold and Hancock²⁶ for its

[†]Present address: Hoechst AG, Postfach 800 320, Angewandte Physik G864, D-6230 Frankfurt 80, Germany.

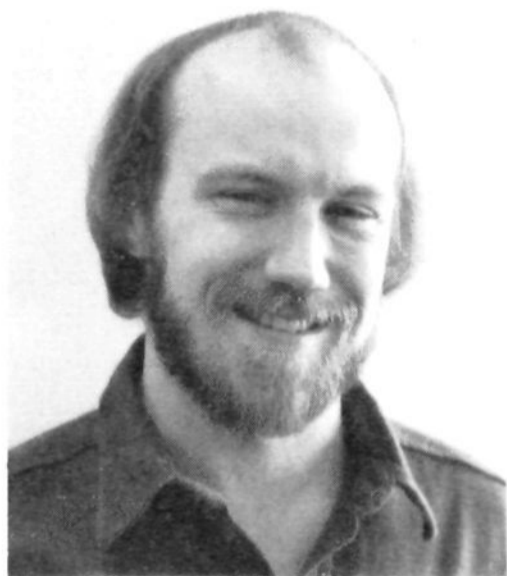

Donald W. Lupo was born in Anderson, SC, in 1956. He attended Davidson College in North Carolina, where he did research in the photophysics of triplet-state aldehydes and ketones under Prof. Merlyn Schuh and obtained a B.S. in chemistry in 1978. He obtained his Ph.D. in physical chemistry in 1984 at Indiana University under Prof. George Ewing for studies of vibrational energy transfer in cryogenic liquids. Since 1984 he has been at the Laboratorium für Physikalische Chemie der ETH-Zürich, where he is involved with investigations of the quantitative kinetics of IR photochemistry.



Martin Quack was born in Darmstadt, Germany, in 1948. He studied in Darmstadt, Grenoble, Göttingen, and Lausanne, where he obtained his doctoral degree working with J. Troe. He subsequently did research with W. H. Miller in Berkeley and habilitated in 1978 in Göttingen. Before his appointment as a full professor for physical chemistry at the ETH Zürich in 1983, he held professorships at the University of Göttingen and the University of Bonn. He has been awarded the Dozentenstipendium des Fonds der chemischen Industrie, the Nernst-Haber-Bodenstein prize of the Bunsengesellschaft für Physikalische Chemie, and the Otto Klung prize of the free University of Berlin. His research interests are in various aspects of chemical reaction dynamics, in particular laser chemistry, intramolecular dynamics from high resolution spectroscopy, and symmetry in chemical reactions. He also enjoys teaching.

critical discussion of experimental work and its interpretation, the article by Danen and Jang²⁷ because of its "chemical" point of view, which is often neglected, and an article on unimolecular reactions,³⁰ which contains a critical discussion of a variety of mechanistic ideas put forward to explain the phenomena in IR photochemistry. Some other articles contain discussions of particular subjects related to IR photochemistry, for instance mode-selective chemistry,³⁴ selective gas-phase photoprocesses,³⁵ two-channel reactions,³⁶ creation and detection of reactive gas-phase species,³⁷

lasers in chemical reactions,^{38,39} and laser-induced bimolecular reactions.^{40,41} Laser isotope separation has been reviewed repeatedly.⁴²⁻⁴⁸ Laser-assisted desorption and processes at surfaces are in many respects closely related to gas-phase IR photochemistry, and we refer to the articles by Heidberg,⁴⁹⁻⁵⁴ Chuang^{55,56} and George and co-workers⁵⁷ for more details, as this important subject will not be further discussed here.

The theoretical aspects, which are essential for understanding the fundamental phenomena and for further experimental progress, have been reviewed from a variety of points of view in ref 58-63. We refer in particular to ref 60 as a starting point for the theoretical part of our review in section 2. We shall not cover again what has already been dealt with extensively in ref 58-63 but rather provide a brief overview of the most recent progress and of the basic principles of our current, quantitative understanding of IR photochemistry. Similarly, the emphasis of our review of experimental progress, after a short summary of the most important *qualitative* experiments, will be on *quantitative* IR photochemistry in section 4. Section 5 finally gives a report on developments of new experimental techniques, and we conclude in section 6 with an outlook—stimulated by an example for the importance of the interaction of theory and experiment in the history of our field.

IR-laser chemistry is a highly interdisciplinary field drawing from such different areas as the theoretical physics of radiative processes including multiphoton absorption and ionization of atoms, laser physics, high-resolution molecular spectroscopy, unimolecular reaction rate theory, nuclear chemistry and isotope research, etc. In this circumstance the comprehensiveness of an article is difficult to define. Our article is certainly not a review of the above mentioned general fields. Section 2 gives a brief outline of the various theoretical approaches, one of which is discussed in more detail in relation to the later sections. A critical review of *all* theoretical approaches is beyond the scope of our article. Unimolecular rate theory is not reviewed, but some relevant equations are summarized in section 2 as well. Section 3 provides a reasonably comprehensive review of the important *types* of qualitative experiments. We have avoided giving a complete table of observed IR-photochemical reactions as these are often only claimed or ill defined. On the other hand, our current theoretical understanding indicates that all polyatomic molecules will undergo IR-photochemistry under appropriate conditions, thus the demonstration of this possibility does not seem to be particularly important. Our summary of isotope separation in section 3 is not competitive but rather complementary to the excellent recent reviews by Lyman⁴⁶ and McAlpine and Evans.⁴⁷ Section 4 is intended to provide in several tables a comprehensive list of all recent IR-photochemical reactions that have in some way been evaluated quantitatively. Our literature search has covered the past 8 years and also included some previous work. Finally, for section 5 we have selected only those advances in laser experiments which seem to us most obviously important for laser chemistry. The advances in laser technology that may *perhaps* become relevant for laser chemistry are so tremendous, that several hundred pages of review could be written over a 5-year period—which is impossible here.

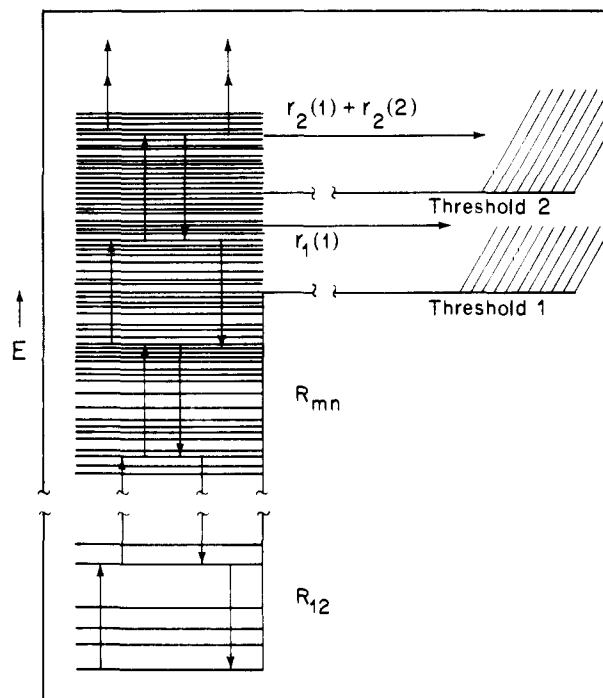

Figure 1. Scheme for IR-multiphoton excitation and chemical reaction with two reaction channels. Reproduced with permission from: *J. Chem. Phys.* 1978, 69, 1282. Copyright 1978, American Institute of Physics.

2. Theoretical Foundations of IR-Multiphoton Excitation and IR Photochemistry

Figure 1 shows an overview of the photophysical and photochemical primary processes occurring in IR photochemistry. There we have in essence the competition between IR-multiphoton excitation, possibly collisions, and chemical reactions as characterized here by two chemical reaction channels. The rate processes R_{mn} and r_k are not yet specified at this point. The quantitative theoretical treatments can be distinguished according to just how they treat these rate processes. Before going into more details, we should give a brief survey of possibilities.

(i) Both the molecular motion and the radiation field are treated by classical mechanics and electrodynamics. Such classical trajectory calculations have appeared rather abundantly.⁶⁴⁻⁷⁵ As for many aspects of IR photochemistry molecular quantum effects seem to be important, we shall not review trajectory calculations in detail. Miller's semiclassical theory⁷⁶⁻⁷⁸ goes beyond this, but there have been few if any calculations for realistic systems in IR photochemistry.

(ii) Both the molecular motion and the field are treated quantum mechanically. An early example of such a treatment using the "dressed atom" model is the paper by Mukamel and Jortner.⁷⁹ It is known, however, that the quantum and classical field treatment give equivalent results for the typical laser fields under consideration.⁸⁰ In the case of the quasisonant approximation⁸⁰ identical equations of motion result from the quantum and classical-field treatments. Therefore in practice the latter has been preferred because of its greater simplicity.

(iii) The molecular motion is treated by quantum mechanics, whereas the radiation field is treated by

classical electrodynamics. This "semiclassical" approach has been most successful in the present context and will be reviewed in sections 2.1 to 2.3 in some detail. It must be distinguished from the "semiclassical" mentioned under (i). It leads to a set of coupled differential equations with periodic coefficients. For the two-level problem this has customarily been solved either with the rotating wave approximation⁸¹ or with the Floquet-Liapunoff theorem.⁸² The extension of the Floquet approach to the many-level IR-multiphoton problem was given in ref 10, where it was concluded from a thorough analysis that the nature of the interaction parameters under typical conditions allows a transformation and subsequent "quasisonant" approximation. These results were elaborated upon subsequently but independently by two research groups, who, for some time thereafter, promoted the Floquet approach^{63,83-93}. We shall discuss the transformation to the quasisonant basis in section 2.3.

(iv) One can furthermore introduce statistical mechanical concepts.^{10,60} These will be discussed in section 2.4 mainly on the basis of master equations.¹⁰⁻¹³ Alternatives are the Bloch equations,^{94,95} which require in this application the initial separation of the "pumped mode", a problem which is also discussed in section 2.2.

(v) The rate equations⁹⁶⁻⁹⁸ using Einstein coefficients for absorption and stimulated (also spontaneous) emission have great similarity with some of the master equations under (iv). However, they have a different origin (not applicable with coherent pumping) and range of applicability, although they sometimes work well, phenomenologically.

(vi) Finally, numerous ad hoc models have been proposed. These will not be reviewed, here, and we refer to an earlier review,³⁰ which provided a critical discussion of some of these.

Our short summary of theoretical approaches may serve as a little guide. We shall now discuss some aspects of the more fruitful approaches. We should stress again that the present section is not intended to provide a comprehensive review of all theoretical approaches. For this we refer to ref 58-63. The present discussion is intended to provide sufficient theoretical background for a meaningful discussion of experiments.

2.1. Quantum Theory of the Excitation of a Quantized Molecular System by a Coherent Classical Radiation Field

The most general starting point for the time-dependent dynamics is the differential equation for the time evolution operator \hat{U} or its matrix representation in some basis:

$$i \frac{\hbar}{2\pi} \frac{\partial \hat{U}}{\partial t} = \hat{H}(t) \hat{U} \quad (2.1)$$

\hat{H} is the time-dependent effective Hamiltonian, which includes the interaction with the radiation field. Using the electric dipole approximation, it takes, for example, the following form

$$\hat{H}(t) = \hat{H}_{\text{Mol}} - \hat{\mu}_z E_z(t) \quad (2.2)$$

\hat{H}_{Mol} is the time-independent molecular hamiltonian, $\hat{\mu}_z$ is the z -component of the dipole operator and $E_z(t)$ the classical electric field strength (z -polarized wave in

the example). $E_z(t)$ is idealized to be a sinusoidal, monochromatic, coherent wave, resulting in a periodicity of $\hat{H}(t)$ (period τ):

$$\hat{H}(t+\tau) = \hat{H}(t) \quad (2.3)$$

More generally, the laser field can be considered as a superposition of several such classical field modes with a slowly varying overall amplitude.¹⁰ For the quantitative simulation of experiments this must be taken into account. For fundamental considerations, the monochromatic wave is a suitable idealization, which leads to certain theoretical simplifications. The extension to several coherent field modes is straightforward, although the solutions are not analytically simple, in general. The other extreme of a statistical population of field modes either for a completely thermal radiation field or an incoherent white light source has also a simple treatment in terms of master equations with generalized Einstein coefficients, but this is less relevant here.⁶⁰

The time evolution operator \hat{U} solves all the relevant quantum mechanical equations of motion, such as the time-dependent Schrödinger equation for the wave function $\psi(x_1, x_2, \dots, t)$, which depends upon time t and the coordinates x_1, x_2, \dots of all particles (electrons and nuclei for a molecular system):

$$i \frac{\hbar}{2\pi} \frac{\partial \psi}{\partial t} = \hat{H} \psi \quad (2.4)$$

$$\psi(t) = \hat{U}(t, t_0) \psi(t_0) \quad (2.5)$$

\hat{U} solves equivalently also the Heisenberg equations of motion and the Liouville–von Neumann equation, as is quite well known,^{60,99} although sometimes the impression has been created in the literature that the solutions of the Liouville–von Neumann equation were somehow more general than the solution of the Schrödinger equation in terms of \hat{U} .

For practical computations the above general equations must be written in some basis states. While from the general point of view the choice of a basis is quite arbitrary, in practice some choices turn out to be better than others.

2.2. The Choice of a Basis: Spectroscopic States

Numerous choices of bases are possible, but we shall discuss here only two of them in order to illustrate the considerations arising in a choice of basis. A first choice of basis suggested quite early by Hodgkinson and Briggs¹⁰⁰ and elaborated upon by several other authors^{58,101} rests on the physical picture that one vibration in the molecule is coupled strongly to the radiation field but only weakly to the other degrees of freedom in the molecule. In practice one has then used reduced equations of motion for this “pumped mode”, which have the advantage to be of low order and also to appeal to physical intuition. The basis corresponding to this approach is diagonal in the quantum numbers of one separable, generally anharmonic oscillator. The following disadvantages of this choice must be noted: (i) Little is known spectroscopically about such separable states, as they are a poor approximation to molecular reality. (ii) It is difficult to incorporate rovibrational

coupling into such a basis. (iii) In the case of the excitation of a thermal ensemble the initial density matrix is not diagonal and its structure is, in fact, poorly defined. In none of the treatments based on this approach have the problems (ii) and (iii) been properly solved in practice. Also, the coupling of the “separable” degree of freedom to the rest of the molecule has been treated by continuum approximations for the spectrum of the so called “bath modes”,^{94,101,102} which is a poor description for small molecules.

Because of these disadvantages of the “pumped-mode” descriptions, we have therefore strongly advocated the use of spectroscopic states, i.e. the eigenstates of the effectively field-free molecular hamiltonian.¹⁰ Strictly speaking, the spectroscopic states may not be considered to be eigenstates for nonplanar molecules or in cases where the nuclear spin splittings are not explicitly considered. Therefore we have preferred the nomenclature “spectroscopic states” over “nuclear molecular eigenstates” NME.¹⁰³ These basis states are the solutions to the time-independent molecular (spectroscopic) Schrödinger equation with hamiltonian \hat{H}_{Mol} :

$$\hat{H}_{\text{Mol}} \phi_k = E_k \phi_k \quad (2.6)$$

The ϕ_k are only functions of the coordinates and the time-dependent Schrödinger equation has the solution

$$\psi(r_{j\dots t}) = \sum_k b_k(t) \phi_k(r_{j\dots}) \quad (2.7)$$

The time-dependent problem alone leads to the following equation for the matrix representation \mathbf{U} of \hat{U} in the basis ϕ_k (see ref 60)

$$i \, d\mathbf{U}/dt = \mathbf{H}(t)\mathbf{U} \quad (2.8)$$

$$\mathbf{H}(t) = \mathbf{W} + \mathbf{V} \cos(\omega t + \eta) \quad (2.9)$$

\mathbf{W} is a diagonal matrix with elements $W_{kk} = 2\pi E_k/h$ and \mathbf{V} is the coupling matrix, which in the electric dipole approximation has the form

$$V_{kj} = -2\pi (\phi_k | \bar{\mu} \tilde{e}_z | \phi_j) |E_0|/h \quad (2.10)$$

This matrix representation of the general equations can be made the basis of a very efficient numerical approach for the following reasons: (i) There is a very large body of knowledge available about the energies E_k and transition moments in eq 2.10 from high-resolution spectroscopy and the corresponding effective molecular Hamiltonians. (ii) Full treatment of both rotation and vibration and their couplings is naturally included. (iii) For the excitation of thermal ensembles the initial density matrix is diagonal and this property is not lost in a subsequent transformation to the quasiresonant approximation (see ref 104 and the discussion below). (iv) It is very easy to select states that are close to resonance in a stepwise multiphoton excitation scheme, as there are no off-resonance contributions to the molecular energy. This fact is practically important when one needs to keep the size of the basis to a minimum in calculations on real molecules.

The choice of the molecular-spectroscopic-state basis may appear to have one disadvantage: The important physical phenomenon of time-dependent intramolecular redistribution is not treated explicitly. However, it is contained implicitly in the spectral properties of the molecular Hamiltonian^{10,60} and can be made explicit whenever this is desired (see ref 104–110 for examples).

Although the "pumped-mode" basis is still in use in some model treatments, it seems that all the quantitative numerical approaches are currently being based upon the spectroscopic-state basis, even by the authors who initially developed the "pumped-mode" approach.¹¹¹ The next point for discussion concerns the practical solution of the matrix differential equation (8), for which two approximations have been used.

2.3. The Quasiresonant and Floquet Approximations

Equation 2.8 represents a coupled set of differential equations with a time dependent coefficient matrix $H(t)$. This may be solved by numerical, stepwise integration schemes. Alternatively, one may use the Floquet theorem for a periodic coefficient matrix (cf. eq 3)

$$\mathbf{U}(t) = \mathbf{F}(t) \exp(\mathbf{A}t) \quad (2.11)$$

$$\mathbf{F}(0) = 1 \quad (2.12)$$

$$\mathbf{F}(t + n\tau) = \mathbf{F}(t), \quad \text{integer } n = 0, 1, 2, \dots \quad (2.13)$$

$$\mathbf{A}(t') = \mathbf{A}(t) \text{ any } t, t' \quad (2.14)$$

This still requires the numerical solution over one (at least one-half¹⁰) optical cycle and subsequent matrix operations. This approach has been discussed in ref 10 and has been made the basis of extensive numerical calculations subsequently.⁸³⁻⁸⁵

It turns out, however, that numerical integration can be avoided by transformation to the quasiresonant basis:

$$\mathbf{c} = \mathbf{S}^c \mathbf{b} \quad (2.15)$$

$$\mathbf{a} = \mathbf{S}^a \mathbf{c} \quad (2.16)$$

The \mathbf{S} are diagonal unitary transformation matrices of the form $S_{kk} = \exp(i\alpha_k t)$. These transformations to the quasiresonant basis have been proposed in ref 10, 60, 104, where it has also been discussed that none of the important advantages of the spectroscopic-state basis mentioned in the previous section is lost by this transformation. An important consequence of the transformation is the simplification of the set of coupled differential equations under the assumption that all couplings of states which are off resonant by more than half the laser frequency may be neglected. This is the "quasiresonant approximation" which treats the multiphoton excitation process as a series of stepwise absorption and emission processes. With this approximation one has a set of coupled differential equations:¹⁰

$$i \, d\mathbf{a}/dt = \left\{ \mathbf{X} + \frac{1}{2} \mathbf{V} \right\} \mathbf{a} \quad (2.17)$$

The coefficient matrix $\mathbf{X} + \frac{1}{2} \mathbf{V}$ does not depend upon time, therefore one has the analytical solution

$$\mathbf{a}(t) = \mathbf{U}^{(a)}(t) \mathbf{a}(0) \quad (2.18)$$

$$\mathbf{U}^{(a)}(t) = \exp \left[-i \left(\mathbf{X} + \frac{1}{2} \mathbf{V} \right) t \right] \quad (2.19)$$

The Liouville-von Neumann equation takes the form (in the quasiresonant basis):

$$\mathbf{P}^{(a)} = \mathbf{U}(t) \mathbf{P}^{(a)}(0) \mathbf{U}^\dagger(t) \quad (2.20)$$

where $\mathbf{P}^{(a)}$ is diagonal for a thermal ensemble as in the case of the basis of spectroscopic states.

It has been shown by analytical considerations that the quasiresonant approximation should be valid for typical conditions of molecular-IR-multiphoton excitation.^{10,60} The transformations have been rederived under the name "rotating-frame transformations" recently, and the same conclusions have been reached again quite independently.¹¹² Numerical tests on the excitation of SF_6 with MW cm^{-2} intensities¹¹³ and on an anharmonic oscillator and a model of ozone with intensities in the GW cm^{-2} and even TW cm^{-2} have demonstrated convincingly the validity of the quasiresonant approximation.¹¹⁴ From these results the following conclusions may be drawn: (i) In general, the quasiresonant approximation for molecular-IR-multiphoton excitation will give better results than the Floquet approximation for a given computational effort. (ii) The physical picture as a stepwise process seems to be quantitatively correct, because direct multiphoton transitions, which are explicitly excluded in the quasiresonant approximation, do not contribute appreciably under typical conditions. Note that the stepwise nature of the process by no means excludes nonlinear intensity effects or the appearance of multiphoton resonances in the frequency spectrum.^{14,115} It may be mentioned that the quasiresonant approximation also avoids the problem of phase averaging, which arises with the use of the Floquet approximation.^{343,344} It appears that most of the recent work in the quantum simulation of IR-multiphoton excitation makes use of the quasiresonant approximation and a set of programs has been published.^{114b}

2.4. Statistical Mechanical Concepts

Statistical mechanical concepts^{10,60} for IR-multiphoton excitation are of interest for two reasons: (i) For any of the larger polyatomic molecules the number of coupled states is much too large for a converged solution along the lines of sections 2.1 to 2.3. (ii) The coarse-grained view of statistical mechanics corresponds closely to many experimental observables and leads to the emergence of new properties. An example of a statistical mechanical equation of motion is the general master equation for coarse-grained-level populations p_N , roughly characterized by the number of absorbed photons (N) and some good quantum numbers but not any detailed quantum state labeling. In matrix notation ($\mathbf{p} = \{p_N\}$) this becomes^{10,60}

$$d\mathbf{p}/dt = \mathbf{K} \mathbf{p} \quad (2.21)$$

The rate coefficient matrix $\mathbf{K} = K_{NM}$ is derivable in an unambiguous way from the effective Hamiltonian matrix $\{\mathbf{X} + \mathbf{V}/2\}$ in eq 2.17 for certain cases. However, the relationship is nontrivial, and in particular one cannot, in general, use rate coefficients which are proportional to radiation intensity and the small-signal absorption cross section ("linear rate equations"). In order to demonstrate the nontrivial nature of the \mathbf{K} -matrix we give in Table I as an example the generally

TABLE I. Intensity-Dependent Rate Coefficients^a

case	B	C	D
$K_{M+1,M}$	I	I	$I^{1/2}$
$K_{M,M+1}$	I	$I^{1/2}$	$I^{1/2}$

^aThe various statistical mechanical cases have been introduced in ref 10 and discussed in further detail in ref 60. For each rate coefficient in Table I there is a well-defined preintensity factor, which depends upon spectral structures. The qualitative behavior is best understood in terms of the power law of the intensity dependence. Case B behavior corresponds to a linear law, similar to ordinary rate equations,⁹⁶⁻⁹⁸ whereas the other cases show intrinsic nonlinear power laws as indicated in the table. Case B and case C are the practically most important cases.

nonlinear dependence upon intensity for three of the important approximate analytical limiting cases with couplings $K_{M+1,M}$ between two adjacent levels. Further interesting rate coefficient schemes can be derived for more complex cases with triplets, quadruplets of levels, etc. For this and more general considerations concerning the validity of such cases we refer to ref 60. Recently, we have formulated the foundations of a fully numerical statistical treatment which allows one to incorporate the spectral structures of a real molecular system in a realistic manner.¹¹⁶

The various statistical mechanical cases for monochromatic, coherent optical pumping must be distinguished from rate equation treatments based upon Einstein coefficients for absorption and stimulated emission as they have been formulated by Lyman,⁹⁷ Grant,⁹⁶ Fuss,⁹⁸ and several other authors, subsequently. In these treatments the rate coefficients can be calculated with the small-signal-absorption cross section $\sigma(\nu)$ and are rigorously proportional to intensity for a one-photon transition:

$$K_{m+1,m} = \left(\frac{I}{h\nu} \right) \sigma_{m+1,m} \quad (2.22)$$

This equation applies, if the *incoherent radiation* is the physics at the origin of the statistical mechanical master equation. The general master equation (2.21) arises from *coherent pumping* and statistical mechanical *coarse graining on molecular quantum states*. The difference has often been overlooked and we refer to ref 60 for a more thorough discussion.

2.5. Summary of the Photophysical Primary Processes of Infrared Multiphoton Excitation and Their Nomenclature

We shall summarize here the most important general mechanisms of multiphoton excitation, providing a nomenclature which allows us to distinguish between them. The mechanisms are indicated by the coupling schemes (\rightarrow) between states $0, 1 \dots j$, with frequency $n_j\omega + x_j$, where n_j is an integer and x_j a frequency small compared to the laser frequency. We also indicate the characteristic intensity dependence of the n -photon process in a given mechanism, possibly including subsequent reactive processes. These are sometimes complicated, only simple limiting cases being mentioned in the summary. The energy of the states l, j, n_j etc. are given in parentheses. The curly brackets indicate that there is a set of states, in general.

(i) DIRECT multiphoton transitions⁸²

$$0 \rightarrow 1 \quad (n\omega + x) \quad \text{odd } n = 3, 5, 7, \dots$$

excitation rate proportional to I^n

(ii) GOEPPERT-MAYER-two-photon transitions¹²²

$$0 \rightarrow 1_j(m_j\omega + x_j) \rightarrow 2(2\omega + x)$$

$m_j > 2$ (intermediate states in an off resonant "continuum")

excitation rate proportional to I^2

generalized Goepfert-Mayer- n -photon mechanism: I^n (any integer n)

(iii) QUASIRESONANT STEPWISE multiphoton transitions¹⁰

$$0 \rightarrow \{1_j(\omega + x_{1j})\} \rightarrow \dots \rightarrow \{n_j(n\omega + x_{nj})\}$$

any integer n , general intensity law $I^{m \leq n}$

special cases:

(a) statistical CASE A¹⁰

excitation rate $\propto I$

(b) statistical CASE B¹⁰ with reaction continuum above level N ; reaction rate constant proportional to $I^{n \leq 1}$ (equality holds without falloff)

(c) statistical CASE C¹⁰ with reaction continuum or case B above level M (statistically off-resonant)

reaction rate constant proportional to $I^{n \leq (M+1)/2}$ (equality holds without fall-off); with some systematic off resonance: $I^{n \leq M}$

(d) statistical CASE D¹⁰ (not demonstrated under experimental conditions)

(iv) INCOHERENT STEPWISE EXCITATION^{123,124}

reaction rates with Einstein coefficients for optical transitions proportional to $I^{n \leq 1}$ (equality holds without fall-off similar to case B above). Similarly one has incoherent direct and Goepfert-Mayer multiphoton transitions

Figure 2 illustrates these mechanisms and coupling schemes. There is no room here for a long discussion of these mechanisms. They are clearly distinct by their coupling scheme, and all contribute, in principle. In practice, coherent IR-multiphoton excitation of polyatomic molecules is dominated by the quasiresonant stepwise mechanism iii, as has been demonstrated again recently.¹¹⁴ Note that mechanisms i and ii cannot be described by the quasiresonant approximation. Sometimes, a nonlinear experimental intensity dependence $I^{n > 1}$ has been taken as qualitative evidence for mechanisms i and ii to be contributing. Such a conclusion is clearly incorrect in view of the nonlinear laws appearing under mechanism iii. On the opposite side, a linear experimental intensity law has sometimes been taken to be evidence for incoherent excitation (mechanism iv). Again this is clearly incorrect because a linear law applies also in the case B of quasiresonant, coherent excitation. We hope that the present summary, which identifies the most important mechanisms, may help in the future to clarify some of the discussions concerning the mechanisms of IR-multiphoton excitation.

We have, for the various mechanisms, indicated the papers where the original derivation has been given. Of course (i), (ii), and (iv) are also discussed to a greater or lesser extent in relevant books on radiative processes.

Often mechanisms i and ii are not properly distinguished, but they are really quite different. The same multiphoton transition (with odd n) can proceed by either mechanism, whereas for even n only the Goepert-Mayer mechanism contributes. Einstein's treatment¹²⁴ for incoherent transitions remains rigorously valid for thermal radiation, for which it was originally derived by an ingenious reasoning in the absence of the full quantum statistical foundations which are nowadays available. The treatment remains also valid for incoherent, nonthermal radiation. The statistical mechanical cases (iii) for stepwise, quasiresonant multiphoton transitions in polyatomic molecules have been derived on the basis of hypotheses about the irregular dynamics of coherent excitation in complex spectra.¹⁰ In particular, the importance of the initial state in case B was pointed out. Subsequent derivations of case B greatly stressed the importance of random couplings¹¹⁷⁻¹²¹ and postulated that these were sufficient conditions for the case B master equation.¹¹⁹ As we have discussed elsewhere in great detail, random coupling is not sufficient and irregular-phase time evolution provides a more general basis for the derivation.⁶⁰ We shall not repeat this discussion here. The result for the case B master equation is similar anyway.

2.6. Chemical Primary Processes: Specific Rate Constants and Product Energy Distribution in Chemical Reactions

On the basis of the scheme of Figure 1, the second primary process besides the optical excitation is clearly the monomolecular reaction above threshold. As in other chemical reactions, the two main questions that arise concern the absolute rate coefficient $k(E, J, \dots)$ for reaction and the distribution over various reaction channels (physical and chemical channels); i.e., for a given product channel

$$P_p(E, J, \dots) = \frac{k_p(E, J, \dots)}{\sum_j k_j(E, J, \dots)} \quad (2.23)$$

The sum runs over all product channels. The rate constants imply that a rate description is adequate for the unimolecular processes. This may not always be true but is often accepted as a starting point. On the other hand, we indicate that the rate coefficients depend upon energy, angular momentum, and other constants of the motion, and further, arbitrary variables characterizing the decaying molecular states.

The unimolecular decay of highly excited molecules has been by itself the subject of numerous investigations and reviews.^{30,34,66,125-136,142-144,253,305,334} We shall discuss here only the most pertinent aspects of the statistical theory of unimolecular reactions including some recent results of importance for IR-laser photochemistry. For the more general background we refer to the papers quoted above and in particular ref 30, 305, 334. For the unimolecular rate constant one may write in the framework of statistical theory:

$$k(E, J, \dots) \leq \frac{W(E, J, \dots)}{h\rho(E, J, \dots)} \quad (2.24)$$

Here, $W(E, J, \dots)$ is the total number of accessible reaction channels at the energy E , total angular momentum

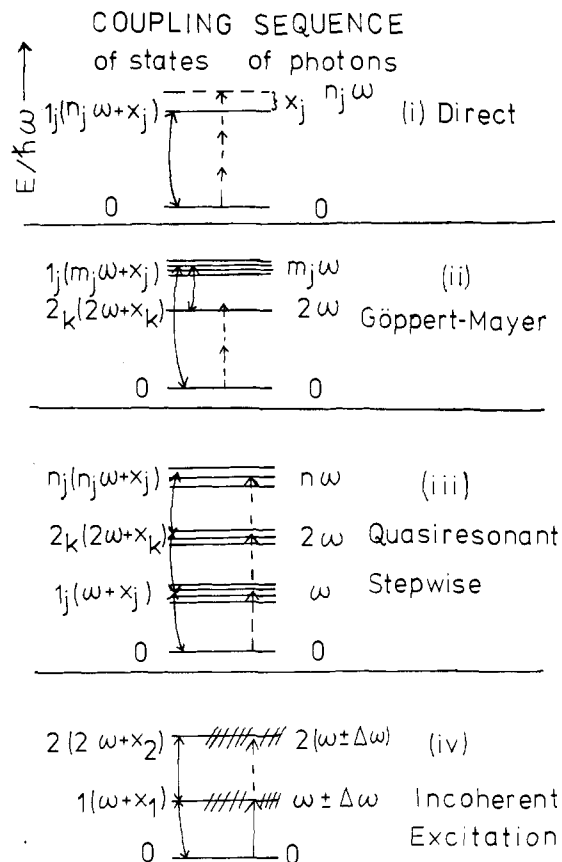

Figure 2. Scheme for various fundamental mechanisms of multiphoton excitation. The full arrows (\leftrightarrow) indicate the coupling scheme between the spectroscopic states. There is no resonance condition for this scheme (e.g., (ii)). The dashed arrows (\rightarrow) indicate the photons of fixed frequency (energy). Various relevant energies discussed in the text have been indicated for the states n_j (left hand part) and photons ($m_j\omega$) with resonance defects x .

J , and other constants of the motion etc., h is Planck's constant and $\rho(E, J, \dots)$ the average density of molecular states at E, J, \dots etc. Equation 2.24 needs some further comments:

(i) Careful derivations for the statistical average rate constant $k(E, J, \dots)$ invariably give an inequality, which in simple physical terms may be seen to arise from the finite rate of intramolecular energy flow.¹³⁰ In practice, one uses the equality for actual computations. This corresponds to the assumption of a microcanonical quasiequilibrium.¹³²⁻¹³⁶

(ii) Depending upon the version of statistical theory one is using, $W(E, J, \dots)$ is to be interpreted either as the number of accessible "quantum states of the transition state" (in RRKM theory)¹³²⁻¹³⁴ or as the number of open adiabatic reaction channels in the adiabatic channel model.¹²⁶⁻¹²⁹ Its computation without¹³²⁻¹³⁶ or with¹²⁶⁻¹²⁹ detailed angular momentum treatment has been discussed extensively in the literature (see also ref 253).

(iii) The density of states $\rho(E, J, \dots)$ has to be interpreted as a statistical average over a small energy interval ΔE . Its computation is usually made with appropriate models for separable oscillators. An aspect which may deserve discussion is the treatment of angular momentum and molecular symmetry, which has found recent attention.^{131,137-140} According to the usual RRKM treatment,¹³²⁻¹³⁶ symmetry is neglected altogether, and the effect of angular momentum is introduced only as a centrifugal correction of the energy

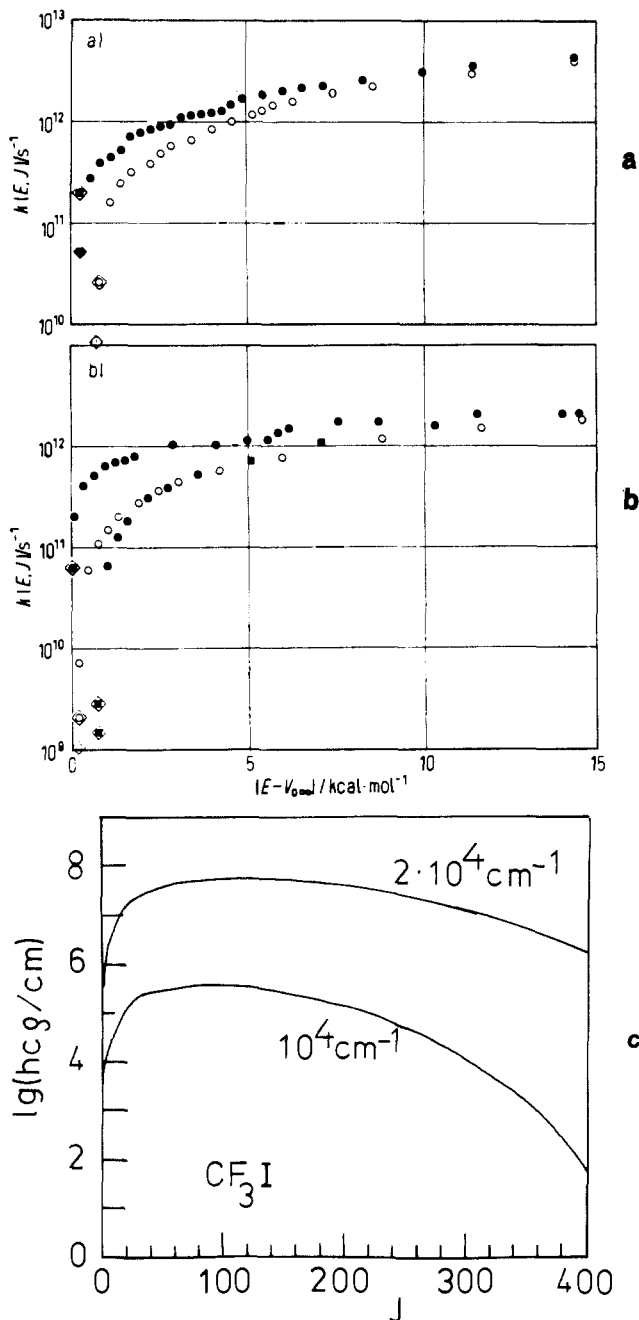

Figure 3. $k(E, J)$ showing the explicit angular momentum dependence of the specific rate constant according to the statistical adiabatic channel model (ref 126): (a) for $\text{O}_3 \rightarrow \text{O}_2 + \text{O}$ $\bullet \hat{=} J = 16$; $\circ \hat{=} J = 40$ (for the IR-photochemistry calculations see ref 14). (b) for $\text{ClNO} \rightarrow \text{Cl} + \text{NO}$ $\bullet \hat{=} J = 0$; $\circ \hat{=} J = 56$; $\blacksquare \hat{=} J = 112$. Two sets of threshold rate constants (\diamond) are given, one taking symmetry into account in $\rho(E, J, \Gamma)$ the other (lower) one not (see ref 131). Reproduced with permission from *Ber. Bunsenges. Phys. Chem.* 1975, 79, 170. Copyright 1975 VCH. (c) $\rho(E, J)$ for CF_3I , showing the angular momentum dependence explicitly for two term values (10^4 cm^{-1} and $2 \times 10^4 \text{ cm}^{-1}$) as indicated. From the values shown one obtains $\rho(E, J, \Gamma)$ by means of the regular decomposition of densities; i.e., $\rho(E, J) = \sum_{\Gamma} [\Gamma] \rho(E, J, \Gamma)$, $[\Gamma]$ being the dimension of the symmetry species Γ (see ref 131 for a detailed discussion).

scale.²⁵³ As was first pointed out in 1974,¹²⁶ it is more consistent to introduce statistical rovibronic coupling (from Coriolis terms in the Hamiltonian) and compute a rovibrational density of states $\rho(E, J, \Gamma, \dots)$, where also the effect of permutation symmetry and parity is taken into account. This has two pronounced consequences

for the statistical theory of IR photochemistry.¹⁰ Firstly, the rate constants $k(E, J)$ become nontrivial functions of angular momentum, as illustrated in Figure 3 for the examples of O_3 and ClNO decomposition.¹²⁷ Of course, similar effects should arise always, although there is no clear experimental evidence for them, so far. The second effect arises in the calculation of the effective density of states in the case B/C master equation. Depending on whether rovibronic coupling is strong or not, one has to insert $\rho(E, J, \dots)$ or a reduced density, which strongly influences the transition from case B to case C at low excitation energies. In case B, the effect of angular momentum is smaller and mainly effects the $k(E, J, \dots)$. Figure 3c illustrates the angular momentum dependence of the density of states and shows that large effects are obviously involved. Note that the one channel rate constant is given by

$$k_1(E, J, \Gamma, \dots) = \frac{1}{h \rho(E, J, \Gamma, \dots)} \quad (2.25)$$

from which one can read directly the influence of $\rho(E, J, \Gamma, \dots)$. For the role of molecular symmetry we refer to ref 131, where it is discussed how $\rho(E, J, \Gamma, \dots)$ results very easily from $\rho(E, J)$ by means of the regular decomposition of the density.

The role of angular momentum and symmetry on product-state distributions has been discussed in ref 138, 142, 143. Combining eq 2.23 and 2.24 the fundamental equation for the population of a certain product p (chemical or physical group of channels, number W_p) is

$$P_p(E, J, \dots) = \frac{W_p(E, J, \dots)}{W(E, J, \dots)} \quad (2.26)$$

$W(E, J, \dots)$ is again the total number of accessible reaction channels and $W_p(E, J, \dots)$ is the number leading to product states p. For a measurable P_p this has to be multiplied with the probability distribution $P_R(E, J, \dots)$ for the fraction of molecules having decomposed with a certain E, J, \dots etc., and integrated and summed over E, J, \dots :

$$P_p = \int_0^\infty dE \sum_{J, \Gamma} P_R(E, J, \Gamma, \dots) P_p(E, J, \Gamma, \dots) \quad (2.27)$$

For instance, the product translational energy distribution in the center of mass system is calculated as (see ref 138, 142, 143)

$$P(E_t, \Delta E) = \int_0^\infty dE \sum_{J=0}^\infty P_R(E, J) P(E_t, \Delta E, E, J) \quad (2.28)$$

Here, we have retained only E and J in the notation. These formulas are applied in section 4. We may note that most evaluations of product energy distributions have used RRKM theory with a less adequate treatment of angular momentum.^{21, 213-220}

2.7. Solutions of the Master Equations and Coarse-Grained Rate Parameters

A generalized statistical mechanical master equation (2.21) including various cases for optical pumping and including specific rate constants for chemical reaction has been first derived in ref 10. On a detailed level, retaining only energy and angular momentum in the

notation explicitly, one has a doubly tridiagonal form in both energy and angular momentum (see ref 10, section V and eq 2.21 of the present review for the definition of \mathbf{K}):

$$\mathbf{K} = \{K_{(E \pm h\nu, J \pm 0, 1), (E, J)}, K_{(E, J), (E, J)}\} \quad (2.29)$$

$$-K_{(E, J), (E, J)} = \sum_{J'=J-1}^{J'=J+1} [K_{(E+h\nu, J'), (E, J)} + K_{(E-h\nu, J'), (E, J)}] \quad (2.30)$$

In addition to J , of course parity and other quantum numbers are to be included, but are omitted for brevity of notation. A full solution along these lines has as yet never been given. The closest approach to it has been a decomposition into an angular momentum part, approximated as a thermal distribution of appropriate temperature, and an energy part, from a solution of a reduced master equation (2.21).¹⁴³ It would, in fact, be worthwhile to continue some work along the general lines of ref 10, but we shall quote here only some properties of the solutions of the master equation which are independent of the energy and angular momentum decomposition and some relevant specific problems related to the solutions in a physical context.

Quite independent of the nature of the rate coefficient matrix, the general solution of the master equation (2.21) is given by eq 2.31¹¹

$$\mathbf{p}(t) = \mathbf{Y}(t, t_0)\mathbf{p}(t_0) \quad (2.31)$$

\mathbf{Y} satisfies the differential equation (2.32)

$$\frac{d\mathbf{Y}}{dt} = \mathbf{K}\mathbf{Y} \quad (2.32)$$

with the initial condition

$$\mathbf{Y}(t_0, t_0) = \mathbf{1} \quad (2.33)$$

In the particular case that \mathbf{K} does not depend upon time, the solution has the analytical form

$$\mathbf{Y}(t, t_0) = \exp[\mathbf{K}(t - t_0)] \quad (2.34)$$

Following ref 11, \mathbf{K} can be transformed to symmetric form \mathbf{K}_S by a diagonal matrix \mathbf{F} (i.e., $(F^{-1})_{kk} = F_{kk}^{-1}$):

$$\mathbf{F}^{-1}\mathbf{K}\mathbf{F} = \mathbf{K}_S \quad (2.35)$$

\mathbf{K}_S can be made diagonal by an orthogonal transformation

$$\mathbf{G}^T\mathbf{K}_S\mathbf{G} = \Lambda \quad (2.36)$$

Hence one has

$$\mathbf{Y}(t, t_0) = \mathbf{F}\mathbf{G} \exp\{\Lambda(t - t_0)\}\mathbf{G}^T\mathbf{F}^{-1} \quad (2.37)$$

The fraction of remaining reactant molecules, F_R , is computed according to eq 2.38:

$$F_R = 1 - F_p = \sum_K \Phi_K \exp(\lambda_K t) \quad (2.38)$$

$$\Phi_K = \sum_N F_{NN} G_{NK} \sum_M F_{MM}^{-1} G_{MK} p_M(0) \quad (2.39)$$

The time-dependent rate coefficient is then:

$$k(t) = -\frac{d \ln F_R}{dt} = \left(\sum_K \lambda_K \Phi_K \exp(\lambda_K t) \right) \left(\sum_K \Phi_K \exp(\lambda_K t) \right)^{-1} \quad (2.40)$$

As discussed in detail in ref 11 and 60, one has similar, starred quantities, derived by replacing the Φ_K by Φ_K^*

$$\Phi_K^* = \sum'_N F_{NN} G_{NK} \sum_M F_{MM}^{-1} G_{MK} p_M(0) \quad (2.41)$$

The \sum' is restricted to levels of the reactant that have zero reaction rate. Thus F_R^* refers to intrinsically stable molecules. F_R^{**} corresponds to after pulse decay (molecules above the reaction threshold):

$$F_R^{**} = F_R - F_R^* \quad (2.42)$$

It follows from the above equations that the long time limit of the rate coefficient is the unique steady state rate coefficient for an irreducible rate coefficient matrix \mathbf{K} .¹¹

$$k(st) = k^*(st) = \lim_{t \rightarrow \infty} k(t) = -\lambda_1 \quad (2.43)$$

If the rate coefficient matrix is reducible, one has as many separate steady-state rate constants as there are irreducible blocks of \mathbf{K} which correspond to a $p_1(0) \neq 0$.

If \mathbf{K} depends upon time through the time-dependent laser intensity $I(t)$, but if we can write approximately

$$\mathbf{K}(t) \simeq \mathbf{K}_I I(t) \quad (2.44)$$

with a constant \mathbf{K}_I , one has the solution:¹¹

$$\mathbf{Y}(t, t_0) = \exp\left\{ \mathbf{K}_I \int_{t_0}^t I(t') dt' \right\} \quad (2.45)$$

One notes immediately that this corresponds to a transformation from time in eq 2.34 to the new variable fluence

$$F = \int_{t_0}^t I(t') dt' \quad (2.46)$$

Thus one has obviously an intensity proportional steady-state rate coefficient

$$k(st) = I k_I(st) = I \lim_{F \rightarrow \infty} \left(-\frac{d \ln F_R}{dF} \right) \quad (2.47)$$

We note that the approximation in eq 2.44 holds only close to case B and if the specific rate constants can be treated as a small perturbation. For a more detailed discussion we refer to ref 11. The above equations can be made the basis of an evaluation of experiments in terms of relevant rate parameters as will be discussed in section 4 in more detail. We conclude our discussion by some pertinent comments.

(i) The definition of a rate coefficient and the possibility of a unique, approximate steady state limit does not depend upon the validity of the master equation (2.21). Poppe⁷⁴ has shown how a steady-state rate coefficient emerges from classical trajectory calculations of the multiphoton dissociation of SF_6 . We have also demonstrated in quantum mechanical and quantum statistical calculations on the IR photochemistry of ozone the validity of the concept of a rate coefficient.^{14,114,116,325}

(ii) A sufficient condition for a unique steady-state rate coefficient is a master equation (2.21) with an irreducible \mathbf{K} and a nondegenerate, nonzero largest eigenvalue λ_1 .¹¹ However, in a real physical situation with a thermal initial distribution before irradiation \mathbf{K} is reducible into several energy shells. This point has been discussed in ref 11. Often one can still define an average

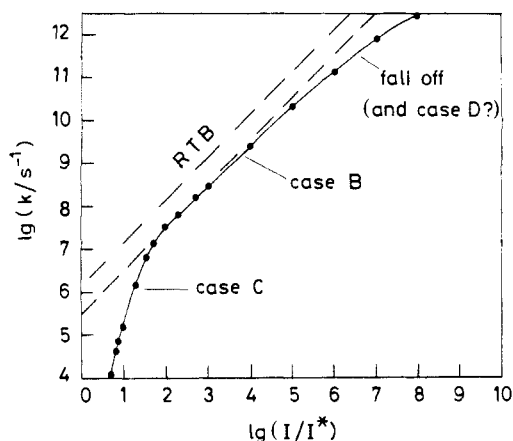

Figure 4. Intensity dependence of the steady-state rate coefficient from the unified case B/case C master equation showing the nonlinearity at low intensities and the falloff at high intensities. Reproduced with permission from *Ber. Bunsenges. Phys. Chem.* 1981, 85, 318. Copyright 1981 VCH.

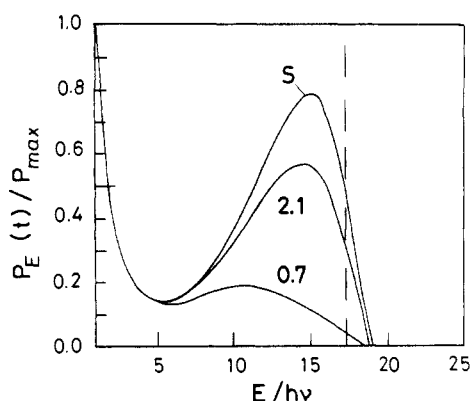

Figure 5. Fluence dependent and steady-state distribution for a model of CF_3I IR-multiphoton excitation in the transition regime of the unified case B/case C master equation. One has two maxima, one at low energies dominated by case C, one at high energies, dominated by case B. The three functions are for a fluence of 0.7 J cm^{-2} and 2.1 J cm^{-2} and steady state (S). The dashed line indicates the dissociation limit. Reproduced with permission from *Chimia* 1981, 35, 463. Copyright 1981 Chimia-Abodienst.

rate coefficient with a smooth distribution. Alternatively, one may have several ensembles reacting with distinct rates.¹¹ It is sometimes suggested that, in particular, the molecules can be divided into reactive and nonreactive molecules (the latter reacting with zero rate constant).^{335,336} This situation is inferred from the concept of rotational holeburning with monochromatic irradiation of moderate intensity. Quantum mechanical simulations indicate that this is a poor description for real life situations with very strong pumping to reaction threshold.^{14,114,116,325,337} Therefore, the evaluation of experiments with the oversimplified two-ensembles model^{335,336} should be viewed with reservation.

(iii) The approximation eq 2.44 with an intensity proportional rate coefficient matrix fails completely in case C, which is often important in practice (see Table I). Then also the steady state rate coefficient depends upon intensity in a nonlinear way. This is summarized in Figure 4. A similar behavior of the rate coefficient could be demonstrated also in quantum mechanical calculations on ozone IR photochemistry, where in ad-

dition also more complicated phenomena were found and explained.^{14,337}

(iv) Another important aspect is the steady-state and time-dependent population distribution over the multiphoton excitation steps. Figure 5 gives some typical examples for relevant intensities from model calculations.¹³ Sometimes, it is suggested that a thermal distribution over energy steps may be used to approximate the populations created by IR multiphoton excitation. This approximation is even quite often used but it is poor quantitatively and qualitatively. We discourage the use of the thermal model.^{247,255}

(v) Usually, eq 2.21 has to take into account explicitly the competition between optical pumping, chemical reaction, and possible collisions. Sometimes, however, one can separate the problem into a fast optical excitation during the irradiation pulse and subsequent reaction (possibly with interfering collisions³⁴²). The problem is then trivially similar to other unimolecular decays of highly excited species (for instance in chemical activation systems^{305,243}), the differences residing in the populations created in the activation step.

(vi) The type of differential equation (2.21) has a long history in mathematics. An early application in reaction kinetics is due to Jost.^{338,339} The approach to the solution of (2.21) given above is a fairly standard one and has been first used in IR-laser photochemistry in ref 10–13 (see also ref 60). It has been reproduced in a virtually identical way in ref 148 and 149 and included further algorithms in ref 340. A somewhat different, numerical solution has been used by Barker.¹⁴⁶ A straightforward numerical, stepwise solution of the system of coupled differential equations is obviously also possible³⁴¹ and has been used.^{96,97} Finally, various closed expression approximations have been given in.^{10,97,152} Of these, the ones obtained by Troe¹⁵² have gone furthest, but still leave room for improvement. One may note, however, that the realization of the general analytical solution in eq 2.37 and 2.45 is not very difficult, in practice. It is to be hoped that in the future more detailed and more accurate, realistic simulations of IR-multiphoton excitation and IR photochemistry become available. These should then help to improve our understanding and planning of qualitative and quantitative experiments in IR photochemistry.

(vii) The expansion of the exact analytical solution in eq 2.37 and 2.40 suggests approximations involving one, two, or more exponential terms in the sum with the parameters ϕ_K and λ_K . For typical conditions a two-term approximation is adequate if the yield is larger than about 1%. A complementary expansion for particularly small yields proposed in case B by Barker and co-workers^{22,146,147} results in a log-normal distribution for the product yield (see also section 4.2.). Recently, Barker and co-workers have also included case C behavior in their considerations.¹⁵¹

3. Qualitative Experiments in IR Photochemistry

The continuing interest in infrared photochemistry is demonstrated by the high rate of appearance of papers in this field. An exhaustive review even of the reports of the last 2 or 3 years would become ponderous. For summaries of work up to the early 1980's we refer the reader to one of the numerous reviews on the sub-

ject (e.g., ref 21 and 28; see also the introduction to this review). In section 4 we discuss quantitative determinations of state distributions, rate coefficients and energy transfer. In this section we stress qualitative investigations and observations which are of particular interest, with emphasis on recent results.

3.1. Isotope Separation Using Infrared Lasers

Early observations that infrared-multiphoton-induced dissociation (IRMPD) could be isotope selective^{4,5,153} helped prompt the initial explosion of research on UR-IMIR. Laser isotope separation (LIS) has continued to be a subject of interest. A computer-assisted *Chemical Abstracts* search listed 51 review articles devoted to LIS as having been published since 1982. Interestingly, of these 17 were Japanese. We shall restrict ourselves to a review of some recent advances, mention of a few important early experiments, and a discussion of the quantification of isotope selectivity experimentally and theoretically. For more exhaustive surveys of progress in LIS up to 1985 we recommend the reviews of Lyman⁴⁶ and of McAlpine and Evans.⁴⁷

Isotope separation schemes, conventional and laser-based, can be described in terms of the isotopic composition of three "streams", the "feeds stream" (mixture before separation) and the "heads" (isotopically enriched) and "tails" (isotopically depleted) output streams.¹⁵⁴ A quantitative description of the separation efficiency of an enrichment process uses the isotopic abundance ratio ξ , given by $\xi = x/(1-x)$, where x is the elemental atom fraction of the desired isotope in a given stream. The separation efficiency is given by the separation factor α or the heads separation factor β , with

$$\alpha \equiv \frac{\xi_{\text{Heads}}}{\xi_{\text{Tails}}} \quad (3.1)$$

$$\beta \equiv \frac{\xi_{\text{Heads}}}{\xi_{\text{Feeds}}} \quad (3.2)$$

Unless α and β are large, or only low enrichment is needed, a practical separation scheme consists of a cascade of stages in which the partially enriched heads stream of one stage becomes the feeds stream for the next stage (for more detail see ref 46 and 47).

From a more theoretical point of view the efficiency of isotope separation can be measured through the molar free energy of separation

$$\Delta G_{\text{sep}} = G_{\text{Feeds}} - yG_{\text{Heads}} - (1-y)G_{\text{Tails}} \quad (3.3)$$

where y is the fraction of feeds going into the heads stream. For ideal mixtures eq 3.3 reduces to

$$\Delta G_{\text{sep}} = -T\Delta S_{\text{sep}} =$$

$$RT(\sum_j x_j^f \ln x_j^f - y\sum_j x_j^h \ln x_j^h - (1-y)\sum_j x_j^t \ln x_j^t) \quad (3.4)$$

Here, x_j^f , x_j^h , and x_j^t are the mole fractions of the j th isotopic species in the feeds, heads, and tails streams, respectively.

Isotope separation with IR lasers is based on the preferential reaction of one isotopically substituted molecule under irradiation. The most obvious source

of isotopic selectivity is the isotopic shift of the irradiated band which allows one species to absorb preferentially. With large isotope shifts one can obtain very high selectivities. Another source of selectivity can be preferential excitation into higher energy levels for one isotopic species due to other isotopic shifts and changes in density of states, plus differences in the transition from case C to case B behavior. An example of this type of selectivity is the preferential dissociation of CDCl_2F over CHCl_2F under irradiation at 1074 cm^{-1} ,¹⁵⁵⁻¹⁵⁷ at which both species have similar absorption strengths.

The unambiguous quantification of IR LIS processes presents special problems. Most schemes use pulsed lasers; the values of α and β depend clearly on the number of pulses. An additional useful quantity is the selectivity S , defined as

$$S = \frac{P_{\text{app}}(1)}{P_{\text{app}}(2)} \quad (3.5)$$

where $P_{\text{app}}(1)$ and $P_{\text{app}}(2)$ are the apparent yields per pulse in the nominal irradiated volume for species 1 and 2 at a given nominal fluence.

The quantities α and β and S alone are also insufficient to provide unambiguous information. Clearly, the nominal fluence must be given as well, since P_{app} depends on fluence. The gas pressure of the photolysed mixture can affect the separation efficiency, as can the starting abundance of the desired isotope; higher selectivity (or a larger number of stages) is required to obtain a pure isotope from a mixture with a few parts per million abundance than is required if the abundance is a few percent. Even under similar nominal conditions yields can be quite different. For CHFCl_2 Gozel et al.¹⁵⁶ found quite different yields per pulse using stable and unstable resonator output configurations at the same nominal fluence in two different laboratories. At higher pressures the temporal shape of the pulse can affect the yield at a given fluence, due to competition between excitation and collisional deactivation at low intensities.¹⁵⁸

A quantity of theoretical interest is the ratio of the steady-state limit of the rate coefficient $k(st)$ for UR-IMIR, in cases where both species react at a given irradiation wavelength. The work of Gozel et al.¹⁵⁶ has shown that $k(st)$, when properly evaluated, is relatively constant from laboratory to laboratory, even when apparent yields are quite different due to different laser conditions. With the steady-state rate coefficients the steady-state separation efficiency would be defined by

$$S_{st} = \frac{k(st)_1}{k(st)_2} \quad (3.6)$$

More generally, one needs to introduce further the activation parameters (activation time, activation fluence, or in general characteristic coefficients and times¹⁰⁻¹²). These are all strongly dependent on intensity, which usually cannot be controlled in practice.

To summarize, unambiguous quantification of laser isotope separation is relatively complicated and researchers in this field are encouraged to report experimental details thoroughly. Particularly important are the irradiation geometry (including the spatial fluence profile of the beam and the resonator type, plus parallel or focused irradiation), the temporal pulse form (e.g.,

mode-locked, single mode, N_2 tail, or ultrashort pulse), partial and total gas pressures and isotopic abundances, number of pulses for a reported α or β , and the apparent yields for both species if both react (thus also the selectivity S). If both molecules react sufficiently, a determination of $k(st)$ for both species is also desirable.

Several factors are important in comparing the economic viability of an LIS process to that of a conventional scheme such as distillation or chemical exchange. An obvious consideration is the cost (in energy and monetary units) of photons needed to bring about the separation. Currently, the laser of choice for most schemes is the TEA CO_2 laser, which can produce high average powers for modest financial outlay and for which the conversion efficiency of electric energy input to laser photon energy is relatively high (of the order of 10 to 30%). LIS with NH_3 ¹⁵⁹ and DF and HF^{160,161} lasers has also been reported.

The feed material for a separation process is also important. The starting compound should either be inexpensive and nonpolluting, or should be recyclable and undergo exchange with an inexpensive natural abundance source under convenient conditions. For most schemes the desired isotopic species should absorb well in the region of CO_2 laser emission and react under moderate fluence, so as to obviate the need for focused geometries.

The heads and tails streams in LIS are physically mixed and chemically different, thus an efficient means of streams separation is also important. In multi-stage schemes the photolysed isotopic species must be easily reconverted into starting material or into another molecule which in turn undergoes isotopically selective URIMIR.

One desires, in addition to high reaction selectivity, the highest possible absorption selectivity, so that the maximum fraction of laser light is used to induce the desired reaction. For the initial stages of a multistage scheme for rare (parts per trillion or less) isotopes the absorption selectivity should be especially large (see ref 47).

In Table II we list some more recent observations of isotope separation using IRMPD, along with some earlier reports. Though we have not made an exhaustive list, we have included at least one example for each element which has been shown to undergo isotopically selective URIMIR.

A great deal of work has been done on the separation of deuterium using IR photochemistry. In part this is due to the large demand for deuterium for research and in ton quantities for heavy-water nuclear reactors. Probably an equally important stimulus is the large isotope shift which leads to high absorption and reaction selectivities. LIS of protium and deuterium is thus fairly easy.

A common feedstock for 2H separation is CHF_3 , which is fairly inexpensive and shows high selectivity. Evans et al.¹⁶² have demonstrated selective photolysis of CDF_3 at natural (~ 150 ppm) abundance at pressures up to 130 mbar, using pulses of <10 nsec FWHM duration to counteract collisional energy-transfer effects. Short pulses are, however, currently expensive. It would be preferable to have a natural-abundance separation scheme using cheaper conventional (>100 ns) pulses. Recently, Parthasarathy et al.¹⁶³ demonstrated 2H en-

richment by the selective dissociation of CDF_3 at natural abundance using conventional pulses at 10–20 mbar CHF_3 . Additional buffer gas was added to suppress scrambling due to energy transfer.

Another promising candidate for deuterium enrichment is $CHCl_2F$, which undergoes relatively rapid base-catalyzed H/D exchange with water. Seyfang¹⁵⁵ and Gozel et al.^{156,157} have irradiated $CHCl_2F/CDCl_2F$ mixtures in the presence of buffer gas between 930–950 cm^{-1} and found very high selectivities. For mixtures highly diluted in the deuterated molecule some loss of selectivity was observed at higher fluences (~ 15 J cm^{-2}). Zhang et al.¹⁶⁴ have also studied this molecule and found very high selectivity both for reaction ($S > 24,000$) and for absorption (~ 4000) by cooling to 200 K and irradiating at 920 cm^{-1} .

A challenge to LIS schemes for deuterium enrichment is the demand for ton-wise quantities of D_2O for nuclear reactors. The chemical exchange process used in Canada⁴⁷ already produces most of the western world's demand for D_2O and is at the large-scale production level an efficient, cost-effective competitor to any laser separation process.

At the other end of the mass spectrum uranium separation via LIS has been of interest because of the need for ^{235}U -enriched fuels for many nuclear reactors. Much research in this area is classified, but there are numerous public reports as well. Weitz et al.¹⁶⁵ synthesized $U(OCH_3)_6$ for convenient IRMPD from a CO_2 laser and observed enrichment in ^{235}U . In general, LIS schemes for uranium based on IRMPD have not shown high selectivities, due to small isotope shifts and spectral congestion. Horsley et al.¹⁶⁶ demonstrated slightly higher selectivity for $UO_2(hfacac)\cdot THF$ in a molecular beam. Two-frequency IR schemes have also been studied, in which a low intensity laser excites one isotope preferentially and a second laser excites to dissociation.¹⁶⁷ There has been research at Los Alamos (see ref 46) on an IR–UV double-resonance process using UF_6 , in which IR radiation excites the desired isotopic species preferentially, and the excited species undergoes UV photolysis. Detailed reports of the success and efficiency of this approach, or lack thereof, are classified.

Perhaps the most promising area for LIS is the realm of moderately light elements such as carbon and sulfur, for which one may expect demand on a research and, perhaps, ton level. The isotopic shifts are large enough that large separation factors can be achieved.

The progress in ^{13}C separation schemes has been particularly promising. Cauchetier et al.¹⁶⁸ reported the production of 90% abundance ^{13}C in one stage by the selective URIMIR of $^{12}CF_3I$, using a silver grid to trap I atoms and collecting and removing C_2F_6 . A second stage produced 99.93% ^{13}C , with 40% of the original ^{13}C remaining.

The LIS group at NRC Canada has reported¹⁶⁹ laboratory scale-up of a two-stage ^{13}C separation scheme in which $^{13}CHClF_2$ is preferentially dissociated. Reaction of the ^{13}C species ensures lower losses of the desired isotope than does depletion of the undesired species. In this work a 100 W TEA CO_2 laser was used to produce ^{13}C -depleted $^{12}CHCl_2F$ and 220 mg h^{-1} ^{13}C at 72% enrichment. The authors extrapolate from laboratory measurements to an annual ^{13}C production rate of 2 kg $year^{-1}$ with this apparatus.

TABLE II. Isotope Separation via IR Photochemistry

isotope	feed source	comments	ref
² H	CHFCl ₂	930–950 cm ⁻¹ ; some loss of selectivity at high fluence	a
² H	CHFCl ₂	920 cm ⁻¹ ; high selectivity for reaction and absorption; 200 and 295 K	b
² H	CHF ₂ Cl	high selectivity at room temperature	aa
² H	CHF ₃	high enrichment, exact selectivity from ¹³ C labeling	cc
² H	CHF ₃	short pulses (<10 ns), pressure to 100 torr, natural abundance samples	c
² H	CHF ₃	standard laser pulse, natural abundance samples, 10–20 torr, with buffer gas	d
² H	CHF ₃	development and testing of exchange feed cycles	e
³ H	CHF ₃	selective decomposition of CTF ₃	f
¹⁰ B, ¹¹ B	BCl ₃	one of the earliest claims of LIS via URIMIR	g
¹⁰ B, ¹¹ B	HClC=CBCl ₂	high selectivity at low P, lower required fluence than for BCl ₃	h
¹³ C	CHF ₂ Cl	two-stage separation scheme, 220 mg/h ¹³ C	i
¹³ C	CF ₃ I	90% abundance ¹³ C in one step, flow system	j
¹³ C	CHF ₃	pressure and temperature dependence	bb
¹³ C	CF ₃ HCl	enhancement of selectivity and yield through multiple frequency irradiation	k
¹³ C	CF ₃ Br	selectivity increased with pressure	dd
¹⁴ N, ¹⁵ N	CH ₃ NO ₂	selectivity with two irradiated bands, also band with no isotope shift	l
¹⁶ O, ¹⁷ O	OCS	IR-UV double resonance, selective also for S and C	m
²⁸ Si, ³⁰ Si	SiF ₄	selective dissociation of ²⁸ SiF ₄ , low separation factors, high threshold fluence	n
²⁸ Si, ³⁰ Si	Si ₂ F ₆	selective reaction of ²⁸ Si and ³⁰ Si with high selectivity and low fluence	o
³⁴ S	SF ₆	early report of LIS (see also ref 4)	p
³² S	SF ₆	selective condensation plus vibrational predissociation, molecular beam	q
³² S	SF ₆	940 mg/h ³² SF ₆ dissociation	r
³⁵ Cl, ³⁷ Cl	CF ₂ Cl ₂	also selective for carbon	s
Mo	MoF ₆	several isotopes selected; low yield and selectivity	t
Se	SeF ₆	NH ₃ laser, enrichment in five isotopes	u
Os	OsO ₄	improved selectivity by use of two frequencies	v
²³⁵ U	U(OCH ₃) ₆	tailoring of molecule to CO ₂ emission range	w
²³⁵ U	UO ₂ (hfac) ₂ ·THF	952.9 cm ⁻¹ , molecular beam	x, z
²³⁵ U	UF ₆	two-color dissociation	y

^a Hason, A.; Gozel, P.; Dupperex, R.; van den Bergh, H. *Appl. Phys. B* 1982, 29, 188. Hason, A.; Gozel, P.; van den Bergh, H. *Helv. Phys. Acta* 1982, 55, 187. Gozel, P.; van den Bergh, H.; Lupo, D.; Quack, M.; Seyfang, G., manuscript in preparation. ^b Linyang, Zhang; Yunwu, Zhang; Xiangxiao, Ma; Peng, Yuan; Yan, Xu; Mengzong, Gong; Fuß, W. *Appl. Phys. B* 1986, 39, 117. ^c Evans, D. K.; McAlpine, R. D.; Adams, H. M. *J. Chem. Phys.* 1982, 77, 3551. ^d Parthasarathy, V.; Sarkar, S. K.; Rao, K. V. S. Rama; Mittal, J. P. *Appl. Phys. B* 1986, 39, 187. ^e Bigeleisen, J.; Hammond, W. B.; Tuccio, S. *Nucl. Sci. Eng.* 1983, 1983, 83, 473. ^f Makide, Y.; Hagawara, S.; Tomimaga, T.; Takeuchi, K.; Nakune, R. *Chem. Phys. Lett.* 1981, 82, 18. Nève de Mévergnies, M.; Verhoeven, F.; del Mermol, P.; Koch, G. *J. Chem. Phys.* 1982, 77, 4786. ^g Ambartzumian, R. V.; Letokhov, V. S.; Ryabov, E. A.; Chekalin, N. V. *JETP Lett.* 1974, 20, 273. ^h Jensen, R. J.; Hayes, J. K.; Cluff, C. L.; Thorne, J. M. *IEEE J. Quant. Electron.* 1980, QE-16, 1352. Abzianidze, T. G.; Abdushelishvili, G. I.; Bakhtadze, A. B.; Gverdtsiteli, I. G.; Kaminski, A. V.; Kudziev, A. G.; Tkeshelashvili, G. I.; Tsinadze, T. B. *Sov. Tech. Phys. Lett.* 1982, 8, 530. ⁱ Outhouse, A.; Lawrence, P.; Gauthier, M.; Hackett, P. A. *Appl. Phys. B* 1985, 36, 63. ^j Cauchetier, M.; Croix, O.; Luce, M.; Tistchenko, S. *Ber. Bunsenges. Phys. Chem.* 1985, 89, 290. ^k Evseev, A. V.; Letokhov, V. S.; Puretzky, A. A. *Appl. Phys. B* 1985, 36, 93. ^l Chekalin, N. V.; Dolzhikov, V. S.; Kolomisky, Yu. R.; Letokhov, V. S.; Lokhman, V. N.; Ryabov, E. A. *Appl. Phys.* 1977, 13, 311. ^m Zittel, P. F.; Darnton, L. A.; Little, D. D. *J. Chem. Phys.* 1983, 79, 5991. ⁿ Lyman, J. L.; Rockwood, S. D. *J. Appl. Phys.* 1976, 47, 595. ^o Kamioka, M.; Arai, S.; Ishikawa, Y.; Isomura, S.; Takamiya, N. *Chem. Phys. Lett.* 1985, 119, 357. ^p Lyman, J. L.; Jensen, R. J.; Rink, J.; Robinson, C. P.; Rockwood, S. D. *Appl. Phys. Lett.* 1975, 27, 87. ^q Philippoz, J.-M.; Zellweger, J.-M.; van den Bergh, H.; Monot, R. *J. Phys. Chem.* 1984, 88, 3936. Philippoz, J.-M.; Calpini, B.; Monot, R.; van den Bergh, H. *Ber. Bunsenges. Phys. Chem.* 1985, 89, 291. ^r Baranov, V. Yu.; Velikhov, E. P.; Kazakov, S. A.; Kolomiiskii, Yu. R.; Letokhov, V. S.; Pis'mennyi, V. D.; Ryabov, E. A.; Starodubtsev, A. I. *Sov. J. Quantum Electron. (Engl. Transl.)* 1979, 9, 486. ^s Fettweis, P.; Nève de Mévergnies, M. *J. Appl. Phys.* 1978, 49, 5699. ^t Freund, S. M.; Lyman, J. L. *Chem. Phys. Lett.* 1978, 55, 435. ^u Tsee, J. J.; Wittig, C. *J. Chem. Phys.* 1978, 69, 4756. ^v Ambartzumian, R. V.; Gorokhov, Yu. A.; Makarov, G. N.; Puretzky, A. A.; Furzikov, N. P. *Sov. J. Quantum Electron. (Engl. Transl.)* 1977, 7, 904. Ambartzumian, R. V.; Furzikov, N. P.; Gorokhov, Yu. A.; Letokhov, V. S.; Makarov, G. N.; Puretzky, A. A. *Opt. Lett.* 1977, 1, 22. ^w Miller, S. S.; DeFord, D. D.; Marks, T. J.; Weitz, E. *J. Am. Chem. Soc.* 1979, 101, 1036. Cuellar, E. A.; Miller, S. S.; Marks, T. J.; Weitz, E. *J. Am. Chem. Soc.* 1983, 105, 4580. ^x Horsley, J. A.; Cox, D. M.; Hall, R. B.; Kaldor, A.; Maas, E. T., Jr.; Priestley, E. B.; Kramer, G. M. *J. Chem. Phys.* 1980, 73, 3660. ^y Rabinowitz, P.; Kaldor, A.; Gnauck, A.; Woodin, R. L.; Gethrer, J. S. *Opt. Lett.* 1982, 7, 212. Rabinowitz, P.; Kaldor, A.; Gnauck, A. *Appl. Phys. B* 1982, 28, 187. ^z Eberhardt, J. E.; Hoare, I. E.; Johnson, D. A.; Knott, R. B.; Pryor, A. W.; Waugh, A. *Chem. Phys.* 1982, 72, 41. Eberhardt, J. E.; Knott, R. B.; Pryor, A. W. *Chem. Phys.* 1982, 72, 51. ^{aa} Moser, J.; Morand, P.; Duperrex, R.; van den Bergh, H. *Chem. Phys.* 1983, 79, 277. Duperrex, R. Dissertation, ETH Lausanne, 1982. ^{bb} Nève de Mévergnies, M. *Infrared Phys.* 1985, 25, 175. ^{cc} Herman, I. P.; Marling, J. B. *J. Chem. Phys.* 1980, 72, 516. ^{dd} Gauthier, M.; Nip, W. S.; Hackett, P. A.; Willis, C. *Chem. Phys. Lett.* 1980, 69, 372.

Chou and Grant¹⁷⁰ observed an interesting temperature dependence in the enrichment of carbon-13 by the IR photolysis of CF₂Cl₂. When frequencies to the blue of the ν₈ absorption maximum at 922 cm⁻¹ were used for irradiation, a 20-fold enhancement in isotope selectivity was obtained by heating the isotopic mixture to near 150 °C. The opposite effect was seen when radiation at 1047 cm⁻¹ at the low wavenumber side of the ν₁ absorption was used; here elevated temperature destroyed isotopic selectivity. Of course, such effects have straightforward "in principle" explanations by means of the detailed spectroscopic properties of the molecules, which in practice are not fully known or analyzed. Certainly, in this case a full understanding

of the observed phenomena needs and deserves further study.

Sulfur isotope separation, usually using SF₆ as feedstock, has been studied frequently, partly because of the status of SF₆ as a "model system" for experimental IR photochemistry. A market for isotopically pure sulfur could exist, for example in the tracing of sources of acid rain by the release of isotopically labeled SO₂ in the vicinity of suspected culprits or in medical applications. One example of sulfur separation is the work of Baranov et al.¹⁷¹ in which selective dissociation at a rate of 940 mg h⁻¹ was demonstrated. Recently, Philippoz et al.¹⁷² have developed an elegant scheme combining selective condensation with infrared vibra-

TABLE III. Observations of Visible and Ultraviolet Luminescence after IR Multiphoton Excitation

reactant	comments	ref
SiF ₄	observation of SiF*	a
C ₂ H ₄ , CH ₂ CN	observation of C ₂ *, CN*, CH*; also other molecules studied	b
BCl ₃	instantaneous luminescence seen, early evidence for collisionless IRMPD	c
C ₂ H ₃ CN	IR and UV luminescence at low pressures (down to 10 ⁻⁵ mbar)	d
C ₂ F ₄ S ₂	fluence dependent emission rise time	e
COF ₂	emission from COF ₂ , early report of IER	f
CrO ₂ Cl ₂	time-resolved fluorescence measured to 5 × 10 ⁻⁶ mbar	g, n
C ₆ F ₆	luminescence of numerous small fragments, proposed observation of C ₃ *, pyrolysis effects possible	h
SO ₂	inverse electronic relaxation to produce SO ₂ *	i, o
tetramethyldioxetane	observation of acetone in mixed T ₁ /S ₁ state	j
OsO ₄	fluence-dependence sequence of emission from OsO ₄ * and excited products	k
SiH ₂ Cl ₂	observation of SiCl ₂ *	l
Ph ₂ CO, PhCOMe, (CH ₃ CO) ₂ , anthraquinone	IR excitation of T ₁ , observation of emission from S ₁	m

^aIsenor, N. R.; Richardson, M. L. *Appl. Phys. Lett.* 1971, 18 225. Isenor, N. R.; Merchant, U.; Halbworth, R. S.; Richardson, M. L. *Can. J. Phys.* 1973, 51, 1281. ^bAmbartzumian, R. V.; Chekalin, N. V.; Letokhov, V. S.; Ryabov, E. A. *Chem. Phys. Lett.* 1975, 36, 301. ^cAmbartzumian, R. V.; Chekalin, N. V.; Doljikov, V. S.; Letokhov, V. S.; Ryabov, E. A. *Chem. Phys. Lett.* 1974, 25, 515. ^dYu, M. H.; Reisler, H.; Mangir, M.; Wittig, C. *Chem. Phys. Lett.* 1979, 62, 439. ^ePlum, C. N.; Houston, P. L. *Chem. Phys. Lett.* 1980, 45, 159. ^fHudgens, J. W.; Durant, J. L., Jr.; Bogan, D. J.; Covaleskie, R. A. *J. Chem. Phys.* 1979, 70, 5906. ^gKarny, Z.; Gupta, A.; Zare, R. N.; Lin, S. T.; Nieman, J.; Ronn, A. M. *Chem. Phys.* 1979, 37, 15. ^hDuignan, M. T.; Grunwald, E.; Speiser, S. J. *Phys. Chem.* 1983, 87, 4387. ⁱSimpson, T. B.; Bloembergen, N. *Chem. Phys. Lett.* 1983, 100, 325. ^jYahar, G.; Haas, Y. *Chem. Phys.* 1978, 35, 41. Haas, Y.; Ruhmann, S.; Greenblatt, O. D.; Anner, O. *J. Am. Chem. Soc.* 1985, 107, 5068. ^kMakarov, A. A.; Makarov, G. N.; Puzetzy, A. A.; Tyakht, V. V. *Appl. Phys.* 1980, 23, 391. Kompa, K. L.; Lamprecht, H.; Schröder, H.; Puzetzy, A. A.; Tyakht, V. V. *J. Chem. Phys.* 1986, 84, 2020. ^lSausa, R. C.; Ronn, A. M. *Chem. Phys.* 1985, 96, 183. ^mBorisevich, N. A.; Zalesskaya, G. A. *Spectrosc. Lett.* 1986, 19, 113. ⁿTsao, J. Y.; Bloembergen, N.; Burak, I. *J. Chem. Phys.* 1981, 75, 1. ^oWolk, G. L.; Weston, R. E.; Flynn, G. W. *J. Chem. Phys.* 1980, 73, 1649.

tional predissociation in a molecular beam. A low-power IR laser in the expansion region excites ³²SF₆, preventing cluster formation for this species and allowing it for ³⁴SF₆. After condensation a second laser excites SF₆, causing the clustered ³⁴SF₆ to predissociate and recoil out of the beam. One may note that the isotope selectivity of IRMPD can be used for mechanistic and other studies in mixtures and natural or only slightly enriched samples of reactive systems.^{169e,f}

Numerous other elements have been shown to undergo isotopically selective IRMPD, although in most cases practical separation schemes have not been proposed. An exception is tritium LIS,^{173,174} which shows high selectivity and which could be used for decontamination of D₂O from nuclear reactors. We list examples of other elements for which isotopically selective URIMIR has been demonstrated in Table II. For more detail and discussion, the reader is referred to ref 46 and 47.

Although LIS has not yet displaced conventional schemes on a commercial level, several schemes for moderately light isotopes show commercial promise. It is in this realm that multiphoton laser chemistry is most likely to achieve what was described by Cantrell in the summation remarks¹⁷⁵ of a conference on multiphoton processes, as a crucial goal of the next few years: the demonstration of a large-scale process based on multiphoton laser chemistry with a clear advantage over conventional approaches.

One reason for the relatively slow progress in the design of efficient separation schemes is the lack of systematic theoretical investigations of isotope separation by IR multiphoton excitation. Some general rules based on case B and C master equations have been put forward in ref 13. However, for quantitative calculations more detailed quantum mechanical and quantum statistical methods are required.¹¹⁶ It is to be expected that some definite results on simple systems will appear in the near future and will speed the progress of this particularly important application of IR photochemis-

try. Of course, in any technological application aspects other than the photophysical and photochemical primary processes are important. A good example is the case of deuterium isotope separation.³³³

3.2. Visible and UV Luminescence after IR-Multiphoton Absorption

Visible and UV luminescence after IR excitation was observed early in the history of IR-laser photochemistry. For example, the IRMPD of SiF₄^{2,3} produced emission from electronically excited SiF, and luminescence from excited C₂ was seen after the dissociation of C₂H₄.¹⁷⁶ Immediate luminescence after IR irradiation of BCl₃¹⁷⁷ was taken to be early evidence for the collisionless nature of IRMPD. In Table III we list observations of luminescence following IR-multiphoton excitation, with emphasis on recent results.

The observation of chemiluminescence after IRMPD can clarify dissociation pathways and identify primary products immediately after dissociation. Haas et al.¹⁷⁸ have demonstrated that tetramethyldioxetane decomposes into two vibrationally excited acetone molecules, one in a mixed singlet/triplet excited electronic state. Sausa and Ronn¹⁷⁹ have deduced from chemiluminescence that SiH₂Cl₂ dissociates under IR-laser irradiation to produce SiCl₂ in the ¹B₁ state.

Duignan et al.¹⁸⁰ have observed broadband chemiluminescence in the IR-laser dissociation of C₆F₆. The results were not simple, and it is not clear how much of the chemistry was thermal.

Luminescence has also been observed from the reactant species through inverse electronic relaxation (IER) from a highly vibrationally excited ground state to an excited electronic state. Simpson and Bloembergen¹⁸¹ observed broadband UV-visible emission from SO₂ which was interpreted as resulting from IER. Kompa et al.¹⁸² have observed fluence-dependent sequences of luminescence after the IR excitation of OsO₄.

TABLE IV. Experimental Investigations of IR Multiphoton Chemistry of Ions

ion	comments	ref
CF ₃ O ⁻	ICR, use of IRMPD to probe collisional relaxation	a
CH ₃ OH ⁻	ICR, determination of k_{st} at 1072 and 939 cm ⁻¹ , activation and collision effects studied	b
[(C ₂ H ₅) ₂ O] ₂ H ⁺	ICR, pulsed and CW, determination of k_{st}	c, d
C ₃ F ₆ ⁺	ICR, pulsed, k_{st} measured	e
benzyl, anilidine, 2,4-hexadienyl, and 1,3-cyclopentadienyl anions	ICR, pulsed, study of electron photodetachment	f
(C ₂ H ₅) ₂ OH ⁺	ICR, CW, laser, determination of k_{st}	g
(ROH) ₂ H ⁺ , R = CH ₃ , etc.	ICR, CW, identification of lowest energy decomposition pathways	h
C ₇ H ₇ ⁺	ICR, CW, identification of structural isomers using electron detachment	i
CF ₃ I ⁺	ICR, CW and pulsed, only X ² E _{1/2} state reacts significantly; k_{st} determined	j, o
CF ₃ I ⁺ , CF ₃ Br ⁺ , CF ₃ Cl ⁺	laser ion coaxial beam spectrometer	o
R(CH ₃) ₂ CO ⁻ R = CF ₃ , Ph, H	ICR, pulsed laser, determination of branching ratios and isotope effects	k
(i-C ₃ H ₇ OH) ₂ H ⁺	QUISTOR, dissociation with 20 W cm ⁻² , measurement of k_{st}	l, m
(C ₄ H ₉) ₂ ⁺	ICR, FT mass spectrometry, dependence of product on precursor for ion	n
SF ₅ ⁺	mass-selected ion beam of SF ₅ ⁺	p
C ₅ H ₁₀ ⁺ , C ₆ H ₁₂ ⁺ , C ₇ H ₁₄ ⁺	FT-MS, loss of C ₂ H ₄ , CW laser, linear intensity dependence	q

^a Jasinski, J. M.; Brauman, J. I. *J. Chem. Phys.* 1980, 73, 6191. ^b Rosenfeld, R. N.; Jasinski, J. M.; Brauman, J. I.; *Chem. Phys. Lett.* 1980, 71, 406. ^c Rosenfeld, R. N.; Jasinski, J. M.; Brauman, J. I. *J. Am. Chem. Soc.* 1982, 104, 658. ^d Woodin, R. L.; Bomse, D. S.; Beauchamp, J. L. *J. Am. Chem. Soc.* 1978, 100, 3248. ^e Jasinski, J. M.; Rosenfeld, R. N.; Meyer, F. K.; Brauman, J. I. *J. Am. Chem. Soc.* 1982, 104, 652. ^f Meyer, F. K.; Jasinski, J. M.; Rosenfeld, R. N.; Brauman, J. I. *J. Am. Chem. Soc.* 1982, 104, 663. ^g Bomse, D. S.; Woodin, R. L.; Beauchamp, J. L. *J. Am. Chem. Soc.* 1979, 101, 5503. ^h Bomse, D. S.; Beauchamp, J. L. *J. Am. Chem. Soc.* 1981, 103, 3292. ⁱ Wright, C. A.; Beauchamp, J. L. *J. Am. Chem. Soc.* 1981, 103, 6499. ^j Thorne, L. R.; Beauchamp, J. L. *J. Chem. Phys.* 1981, 74, 5100. ^k Tumas, W.; Foster, R. F.; Brauman, J. I. *Isr. J. Chem.* 1984, 24, 223. ^l Hughes, R. J.; March, R. E.; Young, A. B. *Can. J. Chem.* 1983, 61, 824, 834. ^m Young, A. B.; March, R. E.; Hughes, R. J. *Can. J. Chem.* 1985, 63, 2332. ⁿ Baykut, G.; Watson, C. H.; Weller, R. R.; Eyster, J. R. *J. Am. Chem. Soc.* 1985, 107, 8036. ^o Coggiola, M. J.; Cosby, P. C.; Peterson, J. R. *J. Chem. Phys.* 1980, 72, 6507. ^p von Hellfeld, A.; Feldmann, D.; Welge, K. H.; Fournier, A. P. *Opt. Commun.* 1979, 30, 193. ^q Bensimon, M.; Rapin, J.; Gäumann, T. *Int. J. Mass Spectrom. Ion Phys.* in press. *Adv. Mass Spectrom.*, Harris, Frank, Ed. Wiley: London, 1986; Vol 10. Tino Gäumann, private communication.

Part of the luminescence is believed to be due to electronically excited OsO₄, and successive sequences are interpreted as emission from primary and secondary products.¹⁸²

IR-multiphoton excitation has recently been used to induce reverse intersystem crossing. Luminescence after IR-laser irradiation of carbonyl compounds in the triplet state was interpreted by Borisevich and Zaleskaya¹⁸³ as evidence for T₁ → S₁ crossing.

3.3. IR Photochemistry of Ions

Because ions are usually studied in a very low-pressure (10⁻⁸–10⁻⁵ mbar) environment, the application of IR photochemistry to these species is a natural and particularly successful idea.

In 1978, Woodin, Bomse, and Beauchamp¹⁸⁴ reported the dissociation of [(C₂H₅)₂O]⁺ over a period of milliseconds using a CW CO₂ laser as the photolysis source for ions in an ICR spectrometer. They were able to determine the rate coefficient for dissociation by measuring reactant depletion in real time. Rosenfeld et al.¹⁸⁵ studied the same ion in an ICR spectrometer under pulsed CO₂ laser irradiation. Beauchamp et al.^{186,187} and Brauman et al.^{188–190} have studied the IR photochemistry of several other ions in ICR spectrometers using pulsed and CW CO₂ lasers. These studies are listed in Table IV, along with other investigations of interest.

IR multiphoton excitation has been used as a tool to probe other processes in ions. Jasinski and Brauman¹⁸⁸ investigated collisional effects at very low pressures by monitoring the pulsed CO₂-laser-induced dissociation of CF₃O⁻. Meyer et al.¹⁸⁹ probed IR-induced electron photodetachment in the benzyl anion and several other anions.

Because the low collision frequency in ICR spectrometers allows very slow IR pumping to the lowest

dissociation channel, CO₂-laser photolysis has been used to determine lowest energy reaction pathways for ions of the form (ROH)₂H⁺.¹⁸⁶ CO₂-laser photolysis has also been used to identify structural isomers of C₇H₇⁻¹⁸⁷ and to investigate branching ratios and kinetic isotope effects in more complex dissociation processes in ions of the form R(CH₂)CO⁻.¹⁹⁰

Hughes et al.^{191,192} have developed an alternative technique to ICR, using a QUISTOR to trap ions at low pressure for IR-laser chemistry. They have observed IR photodecomposition at ~20 W cm⁻² for a series of alcohol-related dimers¹⁹¹ and measured $k(st)$ as a function of pressure and temperature for the URIMIR of (CH₃OH)₂H⁺ and [(CH₃)₂CHOH]₂H⁺.¹⁹²

In conclusion, the use of low-pressure ICR and QUISTOR techniques to study IR photochemistry has enriched the field by allowing the observation of UR-IMIR at low intensities and long times with relatively little interference from collisions. On the other hand, the technique of IRMPD has proven to be useful for the investigation of ion structures and chemistry.

3.4. IR Photochemical Production of Radicals

IR photochemistry has become a useful means of generating radicals in gas phase reaction kinetics. Using IR-laser photolysis one can produce the desired radicals in the ground state under mild conditions at room or other ambient temperatures, which is often difficult with other methods. The time scale of radical preparation is short, allowing measurements of rapid reactions in real time. When wall effects are troublesome, it is possible to generate radical species and investigate kinetics away from walls. Table V lists a number of radical species which have been created and studied using IR photochemistry.

Rossi et al.¹⁹³ used the very low-pressure photolysis (VLP Φ) technique to study reactions of CF₃ with sev-

TABLE V. Production of Radicals through IR Laser Photodissociation

radical	source	comments	ref
CF ₂	CF ₂ HCl	recombination kinetics studied with mass spectrometry	a
C ₃ H ₅	C ₃ H ₅ Br	kinetics of reactions with NO ₂ and Br ₂ , photoionization mass spectrometry	b
CH ₃	C ₆ F ₅ OCH ₃	kinetics of reaction with NO ₂ , photoionization mass spectrometry	c
CF ₂ Cl, CH ₃ CO via Cl	CF ₂ Cl ₂ and C ₄ F ₅ Cl	production of Cl with IRMPD, reaction of Cl with acetaldehyde to produce CH ₃ CO; kinetics of reactions with NO ₂ studied	d
CHF	CH ₂ F ₂	LIF detection of CHF, kinetics of reactions with O, N, NO, and NO ₂	e
NCO	C ₆ H ₅ NCO	LIF detection, kinetics of reactions with NO	f
C ₃	C ₃ H ₄	LIF detection, reactions with NO and O ₂	g
CF ₃	CF ₃ I	VLPΦ, mass spectrometry, kinetics of reactions with Br ₂ , ClNO, O ₃ , and NO ₂	h
CF ₃	CF ₃ I	VLPΦ, mass spectrometry, absolute rate of recombination to C ₂ F ₆ determined	i
SiH ₂	RSiH ₃ (R = n-C ₄ H ₉ , C ₆ H ₅ , C ₂ H ₅)	observation with LIF, clarification of photochemical dissociation pathway for RSiH ₃	j, k
OH	CH ₃ OH	photofragment spectroscopy	l

^a Martinez, R. I.; Huie, R. E.; Herron, J. T.; Braun, W. *J. Phys. Chem.* 1980, 84, 2344. ^b Slagle, I. R.; Yamada, F.; Gutman, D. *J. Am. Chem. Soc.* 1980, 103, 149. ^c Yamada, F.; Slagle, I. R.; Gutman, D. *Chem. Phys. Lett.* 1981, 83, 409. ^d Slagle, I. R.; Gutman, D. *J. Am. Chem. Soc.* 1982, 104, 4741. ^e Hancock, G.; Ketley, G. W.; MacRobert, A. J. *J. Phys. Chem.* 1984, 88, 2104. ^f Cookson, J. L.; Hancock, G.; McKendrick, K. G. *Ber. Bunsenges. Phys. Chem.* 1985, 89, 335. ^g Lesiecki, M. L.; Hicks, K. W.; Orenstein, A.; Guillory, W. A. *Chem. Phys. Lett.* 1980, 71, 72. ^h Rossi, M. J.; Barker, J. R.; Golden, D. M. *J. Chem. Phys.* 1979, 71, 3722. ⁱ Selamoglu, N. L.; Rossi, M. J.; Golden, D. M. *Chem. Phys. Lett.* 1986, 124, 68. ^j Thomas, J. W., Jr.; Steinfeld, J. I. *Chem. Phys. Lett.* 1986, 124, 35. ^k Rayner, D. M.; Steer, R. P.; Hackett, P. A.; Wilson, C. L.; John, P. *Chem. Phys. Lett.* 1986, 123, 449. ^l Schmiedl, R.; Meier, U.; Welge, K. H. *Chem. Phys. Lett.* 1981, 80, 495.

eral radical scavengers. CF₃I underwent IRMPD in the presence of scavengers at low pressure in a Knudsen cell connected to a mass spectrometer. When reactant flow rate was varied and products were monitored the rate constants for the reactions were determined. Recently this method was extended to obtain an absolute value for the recombination rate constant for the formation of C₂F₆ from CF₃.¹⁹⁴ Martinez et al.¹⁹⁵ also used IR photolysis with quadrupole mass spectrometry to study the kinetics of recombination of CF₂ radicals produced by the IRMPD or CHClF₂.

Gutman and co-workers¹⁹⁶⁻¹⁹⁸ have combined the IR-photochemical generation of radicals with sensitive and selective detection of reactants and products via photoionization mass spectrometry in the reaction of radicals with NO₂ and Br₂. They have also used a strategy of reacting IR-generated Cl atoms with radical precursors¹⁹⁸ to avoid secondary IR photolysis of radicals which react under infrared-laser irradiation.

A fast, selective, and sensitive detection scheme which has been useful in kinetic studies of IR multiphoton-generated radicals is laser-induced fluorescence.²²¹ Hancock et al.¹⁹⁹ have combined IRMPD with LIF to determine the rate constants for reaction of CHF and NCO radicals with several collision partners. Lesiecki et al.²⁰⁰ studied reactions of electronically excited C₃ with NO and O₂ by dissociating C₃H₄ in the presence of these species and following the concentration of C₃ via LIF.

The combination of URIMIR and LIF can also be used to elucidate dissociation pathways from IR photolysis which are not clear from bulk measurements due to further reactions. Two recent examples of this are the independent observations via LIF of SiH₂ resulting from the photolysis of alkylsilanes, reported recently by Thomas and Steinfeld²⁰¹ and by Rayner et al.²⁰²

IR photochemistry has been shown in numerous investigations to be a useful generator of free radicals. We may expect it in the future to contribute further to our understanding of radical processes. Of course, often there are competing dominant molecular elimination channels, such as in the dissociation of propynal, which was found to yield only C₂H₂ and CO.²⁰³ Whenever a reaction proceeds cleanly as a molecular process, it is particularly suited for quantitative studies.

3.5. The Chromophore Principle and Mode-Selective IR Photochemistry

IR-multiphoton excitation is highly frequency selective and thus IR photochemistry shows high intermolecular selectivity. An example is the selection of an isotopomer out of a mixture, but in principle also of any kind of chemical impurity in a mixture. This selectivity, discussed in part in section 3.1., is not subject to any doubt and has substantial potential for future practical applications (Scheme I).

The second kind of selectivity has, however, created heated debates, as it is required that laser excitation somehow allows at least partly localized, selective excitation within a molecule, thus intramolecular selectivity (Scheme II). The main, obvious difference in Scheme II compared to Scheme I is that the two excitation and reaction sites are now linked by chemical bonds, which presumably allow efficient transfer of possibly localized excitation energy at either end. It is also clear that there are special, intermediate situations between the two cases, for instance, if in Scheme II the connecting link is a van der Waals bond. We shall in this section address only the cases with true, ordinary chemical bonds. We may mention to begin with that IR photochemistry with intramolecular selectivity has a parallel in chemical activation experiments with site-selective activation.^{34,205-208} The general conclusion from this work has been that intramolecular redistribution of energy occurs within picoseconds or less. One might mention that the total amount of actual evidence is limited, indeed, both qualitatively and quantitatively. Recent more detailed spectroscopic investigations have provided evidence that redistribution can be extremely fast (in less than 0.1 ps) but also quite slow, depending on circumstances.¹⁰⁵⁻¹¹⁰ We shall address here only the work related to laser excitation. Depending on whether or not one assumes redistribution to be fast, i.e., before reaction occurs, which defines the time scale in IR photochemistry to be nanoseconds, ordinarily, one can derive three limiting principles for IR photochemistry, all of which are useful, when applicable:

(i) *The chromophore principle*²⁰⁹ of IR photochemistry states that reaction channels 1 and 2 (and 3 and so on) will be populated independent of the chromo-

SCHEME I. Intermolecular Selectivity

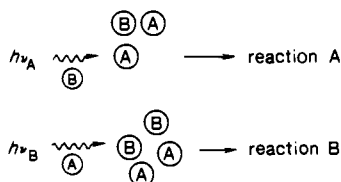

SCHEME II. Intramolecular Selectivity

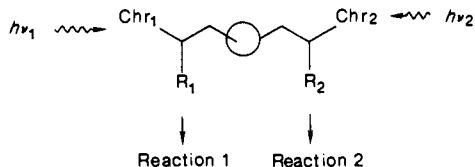

phore (1, 2, etc.) selected by the laser frequency. More precisely, the relative IR-photochemical yield depends upon two separate parts. One concerns the energy (and angular momentum etc.) distributions created during laser excitation. This part *does* depend upon the spectral properties of the chromophore and can thus be different for different chromophores. The second part depends only upon the reactive properties of the highly excited states created by excitation. It is assumed that these are the same for a given set of good quantum numbers (E, J , etc.). The chromophore principle implies that there are no relevant coherences between these excited states, creating localized excitations, but rather that excitation is *global*.¹⁰ In a simple kinetic language it implies that the rate of intramolecular redistribution is fast compared to the rate of reaction. An example for the consequences of the chromophore principle is the reaction

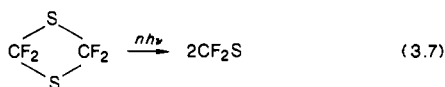

This reaction can be induced either by exciting the CF_2 -chromophore near 1080 cm^{-1} , ν_{16} ,³¹⁰ or the ring chromophore, ν_{14} , closely related to the reaction coordinate.³¹¹ Because of the chromophore principle the more intense CF_2 chromophore gives the same reaction as the ring chromophore and even more efficiently, because it is more intense. A small residual effect in favor of the ring chromophore was interpreted to be insignificant within the relatively large experimental and secondary theoretical uncertainties and would need a more detailed investigation. The present evidence is consistent with fast redistribution. This example is, to our knowledge, the only one where the reactive properties in one channel have been studied quantitatively with *two* chromophores. The opposite situation, i.e., branching in *two* reaction channels with *one* chromophore has been the subject of many studies. These have been reviewed extensively,^{21,26,36} and we shall not duplicate these discussions. Clearly, in this situation the chromophore principle leads to the following expression for the branching ratio, as a function of time:

$$\frac{R_1}{R_2} = \frac{\int_0^{t_p} \int_E \int_J \dots \int P(E, J, \dots, t) k_1(E, J, \dots) dt}{\int_0^{t_p} \int_E \int_J \dots \int P(E, J, \dots, t) k_2(E, J, \dots) dt} \quad (3.8)$$

SCHEME III

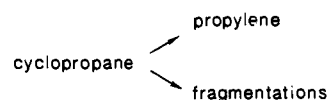
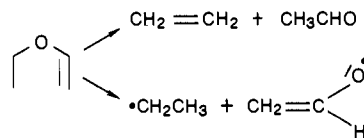
SCHEME IV. Early Investigations of Ethyl Vinyl Ether³¹⁸⁻³²⁰

The distributions $P(E, J, \dots, t)$ are independent of the channel (they *do* depend upon the chromophore and radiation properties). The rate constants k_1 and k_2 to the different channels depend only upon good quantum numbers E, J, \dots etc. in the framework of statistical theories. The evaluation of branching in different physical channels will be discussed in section 4.1. Most authors have obtained consistency with both the chromophore principle and RRKM theory, but the subject has been very controversial²¹ (see below). We may note that a number of simple limiting expressions and an ultra-simple quantum model for branching were presented quite early.¹⁰

(ii) *The principle of state selective reaction control* is based upon the observation that individual energy eigenstates (or strictly scattering resonances) can be excited by IR-multiphoton absorption, under certain circumstances.^{14,210,337} Each scattering resonance is expected to have different partial widths for decay into different chemical and physical channels, and may thus be used to control the reaction. In practice, it will be difficult to do such an experiment and no attempts are known.

(iii) *The principle of mode selection for reaction control* makes use of localized or otherwise specific excitation modes, which are more or less coherent superposition states. An excitation mode according to this terminology could be a delocalized normal mode, a local mode or more generally a localized group excitation in the left or right hand part of Scheme II. In a simple kinetic picture one has then a pumping rate, say, with $h\nu_1$, a reaction rate for reaction 1, a redistribution rate for transfer of the excitation to other parts of the molecular system and finally reaction rate 2. Mode selective reaction control will be possible if the redistribution rate is small compared to pumping and reaction. In the simplest case, the chromophore CH_1 and the reaction center R_1 coincide in the same bond, thus "bond selective chemistry", but obviously more general situations are easily envisaged, and in practice presumably more relevant. Mode-selective reaction control has been claimed repeatedly in IR photochemistry and has been refuted on the basis of substantial arguments in all cases known to us. We refer, in particular, to five reviews covering the last 7 years.^{21,22,26,30,60,36} We mention here only the historical example of CFCl_3 ,²⁰⁴ which has been definitely refuted^{214,323} and several further claims, discussed by Ashfold and Hancock.²⁶ The typical experiment has considered a two-chemical channel reaction (Scheme II) with one or two irradiation frequencies. Examples are in Schemes III-VI.³¹²⁻³¹⁷ Only in a few cases, several irradiation frequencies were used.

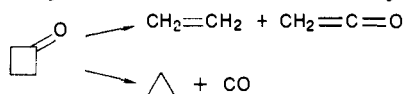
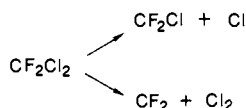
SCHEME V. Cyclobutanone IR Photochemistry^{293,321}SCHEME VI. Simple Two-Channel Reaction of CF_2Cl_2 ^{214,215,229,322-324}

In *no* case has the association of a given reaction channel with a certain chromophore been obvious. We do not think that in any specific example there has been conclusive, compelling, or even moderately convincing evidence that mode-selective reaction control has been achieved. We do not want to present a discussion of specific cases, but will mention a few considerations that should help avoid misinterpretation (and misplanning) of experiments (apart from very trivial problems that occur, in fact, with many experiments).

(i) Branching into different chemical channels from IR photochemistry which is not mode selective may be very different indeed from thermal branching or branching after chemical activation. This is simply due to the different reactive populations $P(E, J, \dots)$ in eq 3.8.

(ii) Nonmode-selective branching can be controlled by means of intensity, fluence, and frequency to a large degree, which is not accessible by any thermal or other means, again via the $P(E, J, \dots)$.

(iii) In particular, the observation of different product distributions from different excitation frequencies is *no proof whatsoever* for mode selective reaction control. Different excitation modes almost always will produce different $P(E, J, \dots)$ and thus different branching without mode selectivity (this control over branching can, of course, still be useful!). It is thus necessary for proof of mode selective reaction control that special precautions are taken to avoid trivial effects on the $P(E, J, \dots)$.

We thus conclude that the available evidence is insufficient to provide any proof for mode selectivity in IR photochemistry. As stated before,³⁰ this does not imply that mode selectivity does not exist, but rather that the right experiments have not yet been done. From a theoretical point of view the prospects for mode selectivity are rather favorable. With very short excitation *and* reaction times and possibly also special systems with delayed intramolecular energy flow, mode selectivity should be abundant. More complex considerations on coherence control and selectivity have been presented as well.²¹¹ We shall conclude this section with some more specific examples for future possibilities.

A recent example, which suggests the theoretical possibility of mode selectivity even in very small molecular systems, is the dissociation of isotopically labeled ozone.³²⁵

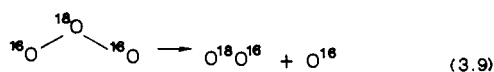

If irradiated with the 1000 cm^{-1} manifold of the two strongly coupled stretching vibrations one predicts easy multiphoton excitation to the lowest threshold, consisting in the loss of ^{16}O only. It seems from spectroscopic evidence that the bending vibration is largely

SCHEME VII

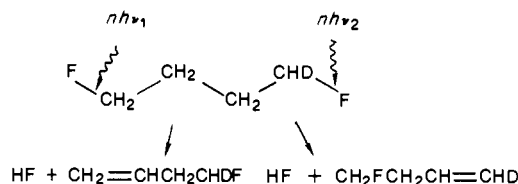

decoupled, although not enough is known at very high energies. Anyway, the bending rovibrational manifold should be accessible to multiphoton excitation by the *p*-H₂ Raman shifted CO₂ laser (see section 5). There is at least a possibility that bending excitation induces isomerization via the D_{3h} isomer of ozone

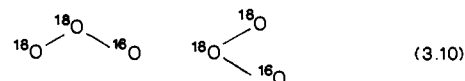

subsequent dissociation would result in loss of both ^{18}O and ^{16}O , which could then serve as a probe for mode selectivity.³²⁵ To be sure, at present the quantum calculations have only predicted multiphoton excitation to threshold in both the stretching and bending manifolds. The potential surface of ozone at high energies, including the D_{3h} isomer, is still subject to debate,³²⁶⁻³²⁸ and the vibrational dynamics at very high excitation is even less well understood. The example may, however, be a good illustration of how to design and prove mode selective reaction control following Scheme II, without taking the geometrical representation of chromophores and reaction centers too literally. Symbolically, Scheme II matches exactly the ozone case. It may be of interest to note that laser excitation of ozone provides also a model for the thermal ignition in this system.³²⁹

The second example which we want to present is an experimental proof of the nonexistence of mode selectivity in a system where great care was taken to avoid the difficulties (i)–(iii) mentioned above²¹² (see Scheme VII).

This system is designed similarly to the fundamental Doering–Rynbrandt/Rabinovitch ideas in chemical activation systems.²⁰⁶⁻²⁰⁸ Investigation of the $-\text{CH}_2\text{F}$ and $-\text{CHDF}$ chromophores in our laboratory has indicated the possibility of excitation at two sufficiently different frequencies in the CO₂-laser range.²⁰⁹ The chromophores are otherwise relatively similar. The reaction is probed by two channels, which differ only by a secondary isotope effect. Therefore this system should, indeed, be mainly sensitive to intramolecular energy flow. However, within experimental uncertainties no mode selectivity was found, which implies intramolecular energy flow on time scales of about 10^{-11} s or less, which is not unexpected. We should note that intramolecular energy flow in the F–C–C–C ... chain was expected to be fast on dynamical grounds and on the basis of spectroscopic investigations.³³⁰ Although the experiment did not reveal any mode selectivity, it is significant perhaps just by this fact and because it seems to be the only case, so far, in which all the experimental precautions have been taken to prove mode selectivity, if there had been any.

We may mention still one experimental example of possibly mode selective vibrational photochemistry, although it was achieved with visible one-photon ex-

SCHEME VIII

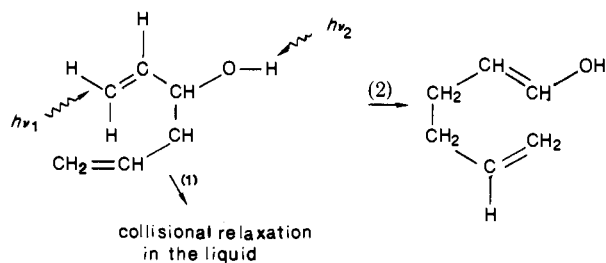

citation³³¹ (Scheme VIII). The two excitation modes concern the overtones of the CH and OH stretch vibrations. The two reaction channels are the Cope arrangement (2), with a subsequent tautomerization not being shown, and collisional stabilization (1). It was found that OH excitation gave only (1), and CH excitation resulted also in (2). Of course, this can either imply that collisional relaxation of the hydrogen bonded OH in the liquid is fast or that intramolecular flow after OH excitation is slow compared to CH excitation. Both would somehow indicate mode selectivity and appeal to intuition. The latter possibility is also consistent with current spectroscopic knowledge about ultrafast redistribution after overtone CH excitation.¹⁰⁵⁻¹¹⁰ It may be mentioned that Benmair and Yogev have also suggested the method of stimulated emission relaxation - not directly related to mode selectivity but useful for reaction control in IR photochemistry.³³² It seems thus possible, although difficult and so far not proven in IR-multiphoton excitation, to achieve mode selection for reaction control. It is in our opinion possible that with a better understanding of the processes of intramolecular energy flow and with short-time (picosecond) IR-multiphoton excitation, mode selectivity may become a useful tool for special applications in chemistry in the future. In this context the prediction of a viable, although somewhat less efficient IR-multiphoton excitation with overtone pumping in the near IR instead of fundamental excitation seems to be of interest.⁶¹ This idea has as yet not been pursued experimentally.

On the other hand, the chromophore principle, which is based upon the assumption of fast intramolecular energy flow and therefore nonlocal excitation, should be eminently useful under typical current experimental conditions. It implies that reaction at any reaction center can be greatly facilitated by attaching a chromophore at some distant place in the molecule, where it neither affects the local structure nor the reaction proceeding at the reaction center itself. This principle, as *opposed* to mode selection, seems to have almost universal validity under typical experimental conditions, and can thus certainly be used in practice. It further distinguishes IR photochemistry from UV-vis photochemistry, where the chromophore principle is clearly less applicable. On a more theoretical level Brumer and Shapiro have most recently proposed a new scheme for *coherent* radiative control in unimolecular reactions.³⁵⁵

4. Quantitative IR Photochemistry

Quantitative, reproducible measurements in IR photochemistry are particularly important to the development of our theoretical understanding of URIMIR and

to its practical application. Several theoretical approaches can explain qualitatively the major features of IR multiphoton absorption and IR photochemistry; however, not all can predict and reproduce quantitative experimental results. Detailed new experimental observations can lead as well to theoretical developments. For the development of practical applications of URIMIR, it is crucial that experimental results be understood quantitatively.

Unfortunately, despite the large number of papers published on IR photochemistry, truly quantitative investigations are still relatively uncommon. Often the physically important quantities simply are not measured. Difficulties in obtaining well-defined spatial fluence profiles and temporal pulse shapes, plus often insufficiently characterized experimental conditions, lead to results that may vary significantly from one laboratory to another.

We discuss in this section progress in quantitative investigations of IR photochemistry in three areas: the measurement of product state distributions, the determination of absolute rate coefficients for URIMIR, and some aspects of collisional energy transfer. In addition, in section 4.3, we present semiempirical formulas for the estimation of absolute rate coefficients in URIMIR.

4.1. Determination of Relative Rates: Translational Energy and Internal State Distributions

Ideally a complete understanding of URIMIR for a given system would require knowledge of the quantitative fluence and intensity dependence of the time evolution of detailed translational energy- and internal-state distributions of reactant and products. Practically only a fraction of this information is obtainable. Broadly one can distinguish two rather different sets of experiments providing information on either of the following:

(i) The relative probability of finding product channels with a certain translational energy of the separating products in the center of mass system. These *product translational energy distributions* are provided mostly by the molecular-beam-time-of-flight technique.^{6,213-220} A more averaged information concerning the *mean translational energy* of the separating fragments is provided by various experiments.

(ii) The relative probabilities of finding product channels with a given internal quantum state for one or both fragments. This is typically measured with the laser-induced fluorescence techniques originally developed by Zare and co-workers.²²¹ If a coincidence experiment were carried out for both product molecules of an IR-photochemical fragmentation this would also define the translational energies, if the initial total energy were known.

Two further kinds of investigation may be mentioned:

(iii) The measurement of the reactant internal-state distributions created by IR-multiphoton excitation and competition with reaction at high energies and

(iv) The measurement of relative yield in chemically different channels. There is little information on the latter two and some of this will be discussed in sections 4.2 and 4.3 (see also 3.5).

TABLE VI. Product Translational Energies from URIMIR

molecule	products	$\langle E_T \rangle /$ kJ mol ⁻¹	comments	ref
SF ₆	SF ₅ , F	<7	TOF mass spectrometry, molecular beam (MB); center of mass energy	a
CHClF ₂	CF ₂ , HCl	35	TOF mass spec, MB; CF ₂ from observation of CF ⁺ ; transient migration LIF results in agreement	b, c, q
CH ₃ CCl ₃	CH ₂ CCl ₂ , HCl	35	TOF mass spec, MB	b
CH ₃ CClF ₂	CH ₂ F ₂ , HCl	53	TOF mass spec, MB	b
CHClCF ₂	C ₂ F ₂ , HCl	4	TOF mass spec, MB; $\langle E_T \rangle$ possibly slightly higher for Cl channel	b
	C ₂ HF ₂ , Cl			
CClF ₃	CF ₃ , Cl	4.6	TOF mass spec, MB	d
CBrF ₃	CF ₃ , Br	5.1	TOF mass spec, MB	d
CF ₃ I	CF ₃ , I	4.6	TOF mass spec, MB	d
CCl ₂ F ₂	CClF ₂ , Cl	8.4	TOF mass spec, MB; Cl ₂ elimination ~10% of product; transient migration LIF in agreement	d, e
	CF ₂ , Cl ₂	20		
CBr ₂ F ₂	CBrF ₂ , Br	6.7	TOF mass spec, MB; transient migration LIF in agreement	c, d
CCl ₃ F	CClF ₂ , Cl	5.1	TOF mass spec, MB; disproved claims of dominant Cl ₂ elimination	d
N ₂ F ₄	NF ₂	1.7	TOF mass spec, MB	d
CH ₃ CH ₂ OCHCH ₂	CH ₃ CHO, C ₂ H ₄	130	TOF mass spec, MB, fraction of radical path higher at high fluence	f
	CH ₂ CHO, C ₂ H ₅	22		
CDCl ₃	CCl ₂ , DCl	11.8	TOF mass spec, MB	g
(C ₂ H ₅) ₂ O	C ₂ H ₅ O, C ₂ H ₅	6.7	TOF mass spec, MB; found radical channel ~80% dominant	h
	C ₂ H ₅ OH, C ₂ H ₄	101		
C ₂ F ₅ Cl	C ₂ F ₅ , Cl	9 (17)	TOF mass spec, MB; value in parentheses is for nominal fluence of, 10 J cm ⁻² , without for F ≈ 0.6 J cm ⁻²	i
	CF ₃ , CF ₂ Cl	10 (17)		
C ₂ F ₅ Br	C ₂ F ₅ , Br	7 (13)	TOF mass spec, MB; parentheses as above	i
CH ₃ NO ₂	CH ₃ , NO ₂	4	TOF mass spec, MB; positive identification of radical channel; earlier MPI measurements reported 39 kJ mol ⁻¹ , did not see second channel	j, k
	CH ₃ O, NO	17		
CF ₃ I	CF ₃ , I	4.2	MPI of iodine, transient migration	q
CCl ₂ F ₂	CF ₂ , Cl ₂	6.3	LIF, low pressure bulk; $\langle E_T \rangle$ based on assumption of Boltzmann distribution and loss of product from probe region	l
	CF ₂ , Cl ₂	16 (3.8)	LIF, transient migration, first value extrapolated for direct channel, second presumed from secondary photolysis	q, r
CBr ₂ F ₂	CF ₂ , Br ₂	7.1	LIF, low pressure bulk, assumption of Boltzmann distribution	l
CHClF ₂	CF ₂ , HCl	29	LIF, low pressure bulk, assumption of Boltzmann distribution	l
CF ₂ CClF	CFCI, CF ₂	1.7 (CF ₃) 1.2 (CFCI)	LIF, low pressure bulk; $\langle E_T \rangle$ based on MB distributions for CHClF ₂	m
CH ₃ ONO	CH ₃ O, NO	~9	LIF, MB; value of $\langle E_T \rangle$ depends on product state of NO	n
C ₂ F ₅	CF ₂ , CF ₃	17	LIF, transient migration, C ₂ F ₅ from photolysis of C ₂ F ₅ I	s
CH ₃ NH ₂	CH ₃ , NH ₂	10	LIF Doppler spectroscopy of NH ₂ , MB; $\langle E_T \rangle$ for NH ₂ fragment only	o
CH ₃ OH	CH ₃ , OH	10	LIF Doppler spectroscopy of OH, MB	p

^a Coggiola, M. J.; Schulz, P. A.; Lee, Y. T.; Shen, Y. R. *Phys. Rev. Lett.* 1977, 38, 17. ^b Sudbo, Aa. S.; Schulz, P. A.; Shen, Y. R.; Lee, Y. T. *J. Chem. Phys.* 1978, 69, 2312. ^c Rayner, D. M.; Hackett, P. A. *Israel J. Chem.* 1984, 24, 232. ^d Sudbo, Aa. S.; Schulz, P. A.; Grant, E. R.; Shen, Y. R.; Lee, Y. T. *J. Chem. Phys.* 1979, 70, 912. ^e Krajnovich, D.; Huisken, F.; Zhang, Z.; Shen, Y. R.; Lee, Y. T. *J. Chem. Phys.* 1982, 77, 5977. ^f Huisken, F.; Krajnovich, D.; Zhang, Z.; Shen, Y. R.; Lee, Y. T. *J. Chem. Phys.* 1983, 78, 3806. ^g Herman, I. P.; Magnotta, F.; Buss, R. J.; Lee, Y. T. *J. Chem. Phys.* 1983, 79, 1789. ^h Butler, L. J.; Buss, R. J.; Brudzynski, R. J.; Lee, Y. T. *J. Phys. Chem.* 1983, 87, 5106. ⁱ Krajnovich, D. J. Ph.D. Thesis, University of California-Berkeley, 1983; Lawrence Berkeley Laboratory publication LBL-153354. ^j Wodtke, A. M.; Hinsa, E. J.; Lee, Y. T. *J. Chem. Phys.* 1986, 84, 1044. ^k Rockney, B. H.; Grant, E. R. *J. Chem. Phys.* 1983, 79, 708. ^l Stephenson, J. C.; King, D. S. *J. Chem. Phys.* 1978, 69, 1485. ^m Stephenson, J. C.; Bialkowski, S. E.; King, D. S. *J. Chem. Phys.* 1980, 72, 1161. ⁿ King, D. S.; Stephenson, J. C. *J. Chem. Phys. Lett.* 1985, 114, 461. ^o Schmiedl, R.; Boettner, R.; Zacharias, H.; Meier, U.; Welge, K. H. *J. Mol. Struct.* 1980, 61, 271. ^p Schmiedl, R.; Meier, U.; Welge, K. H. *J. Chem. Phys. Lett.* 1981, 80, 495. ^q Rayner, D. M.; Hackett, P. A. *J. Chem. Phys.* 1983, 79, 5414. ^r Rayner, D. M.; Kimel, S.; Hackett, P. A.; *Chem. Phys. Lett.* 1983, 96, 678. ^s Rayner, D. M.; Kimel, S.; Hackett, P. A. *J. Chem. Phys.* 1983, 77, 349.

In the determination of product translational energy and internal-state distributions there has been considerable progress. A detailed discussion of advances to about 1981 has been given in the review by King,²⁸ however, with little attention to the theoretical analysis. Two earlier reviews are also particularly relevant.^{21,26} In this section we discuss the primary methods used to determine energy and state distributions and summarise some important results, particularly advances since 1981.

Several methods have been used to determine fragment recoil translational energies in URIMIR. In Table VI we list reports in which the translational energy distributions or average translational energies were determined for one or both fragments.

Lee et al.^{6,213-220} have made a number of measurements of translational energy distributions using angle-resolved time-of-flight (TOF) mass spectrometry to detect fragments from IRMPD in supersonic beams.

Early results for SF₆^{6,213} were interpreted as evidence for rapid energy randomization and statistical behavior in URIMIR. Direct observation of primary products from IRMPD of CCl₃F²¹⁴ proved that the only significant reaction channel was the energetically favored Cl elimination, contrary to earlier assertions.²⁰⁴ Recently Wodtke et al.²²⁰ have postulated a previously unknown reaction channel in the URIMIR of CH₃NO₂. The general observation of the TOF mass spectrometry molecular beam studies has been that simple bond rupture reactions produce fragments with low kinetic energy, while molecular elimination products tend to recoil with kinetic energies determined by the activation barrier for the reverse reaction.

Optical methods have also been used to probe translational energies, primarily via laser induced fluorescence (LIF). Stephenson et al.²²²⁻²²⁴ have reported average product translational energies based on the time required for the products to translate out of

TABLE VII. Product Internal State Distributions from URIMIR

product observed	reactant	reported distribution	comments	ref
CN ($X^2\Sigma^+$)	CH ₃ CN	T_R ($\nu = 0$) = 730 K T_R ($\nu = 1$) = 809 K $T_V = 793$ K	LIF, bulk; lowest possible pressure results quoted; T_V from ratio of ($\nu = 1$) to ($\nu = 0$)	a
CN ($X^2\Sigma^+$)	C ₂ H ₃ CN	$T_R = 970$ K at 160 ns $T_R = 435$ at 3 μ s $T_R = 682$ K at 560 ns $T_R = 435$ K at 2.85 μ s $T_R(\text{max}) = 740$ K $T_R = 780$ mode locked $T_R = 570$ K single mode	LIF, bulk LIF, MB; C ₂ CN proposed as direct precursor; high T_R at long time with plasma shutter LIF, bulk	b c d
CN ($X^2\Sigma^+$)	CF ₃ CN	$T_R = 1200 \pm 100$ K $T_V = 2400 \pm 200$ K	LIF, bulk; consistent results from two laboratories	e
CF ₂ (X^1A_1)	CF ₂ Cl ₂	$T_R = 550 \pm 50$ K $T_V = 1050 \pm 100$ K	LIF, bulk; T_R independent of vibrational state	f, g
CF ₂ (X^1A_1)	CF ₂ Br ₂	$T_R = 450 \pm 25$ K $T_V = 790 \pm 70$ K	LIF, bulk	f, g
CF ₂ (X^1A_1)	CHClF ₂	$T_R \sim 2000$ K $T_V = 1400\text{--}2000$ K	LIF, bulk; T_V measured as function of intensity with square-wave pulses; lower value for ~ 55 MW cm ⁻² , higher ~ 3.3 GW cm ⁻²	g, h
CF ₂ (X^1A_1)	CF ₂ CClF	$T_R = 1550 \pm 150$ K T_V (ν_1, ν_3) ~ 1100 K T_V (ν_2) = 900-1400 K	LIF, bulk; T_V measured as function of I with square-wave pulses; lower value for $I \sim 55$ MW cm ⁻¹ , higher 3.3 GW cm ⁻¹	h, i
CFCI (X^1A_1)	CF ₂ CClF	$T_R \gg 400$ K T_V (ν_1, ν_3) ~ 900 K T_V (ν_2) = 1550 \pm 300 K	LIF, bulk	i
NO(² $\Pi_{1/2,3/2}$)	CH ₃ ONO	T_R (² $\Pi_{1/2}$) = 400 \pm 10 K T_R (² $\Pi_{3/2}$) = 530 \pm 100 K ² $\Pi_{1/2}$: ² $\Pi_{3/2}$ = 2.7:1	LIF, MB, square-wave pulses (50 ns); multiplicity preference disappears for $J > 24.5$	j
NH ₂ (X^2B_1)	CH ₃ NH ₂	$T_R \sim 500$ K	LIF, MB	k
NO ($X^2\Pi$)	NO ₂	$T_R \sim 300$ K $T_V \leq 240$ K	LIF, MB; UV-IR double resonance: NO ₂ excited at 435.7 nm	l
OH ($X^2\Pi$)	CH ₃ OH	$T_R = 1250$ K (100 ns) $T_R = 400$ K (1.6 μ s) $T_R = 630 \pm 30$ K	LIF, bulk LIF, MB	m n
CH ($X^2\Pi$)	CH ₃ CN	$T_R = 622 \pm 113$ K	LIF, bulk; lowest pressure result for ($\nu = 0$)	a
C ₂ ($a^3\Pi_u$)	C ₂ H ₃ CN	$T_R = 700 \pm 200$ K T_R ($\nu = 0$) = 400-600 K	LIF, bulk, C ₂ presumed to arise from secondary photolysis of C ₂ CN LIF, bulk; higher value from intense part of CO ₂ pulse, lower at ~ 8 μ s delay	o c
C ₂ ($a^3\Pi_u$)	C ₂ H ₄	$T_R = 1006 \pm 150$ K $T_V = 1181 \pm 150$ K	LIF, bulk; lowest pressure measurement reported	p
CH ₃	CH ₃ NO ₂	$T_R < 1100$ K	MPI, MB; NO ₂ also warm rotationally, but no T_R reported	q
HF	CHF ₂ CH ₃	($\nu = 1$) > ($\nu = 2$) > ($\nu = 3$) > ($\nu = 4$) $T_R = 1000$ K neat $T_R = 450$ K in He	IR fluorescence, bulk	r
	C ₂ H ₃ F	($\nu = 1$) > ($\nu = 2$) > ($\nu = 3$) > ($\nu = 4$) $T_R = 500$ K	IR fluorescence, He as buffer gas	r
	C ₂ H ₅ F	($\nu = 1$) > ($\nu = 2$) > ($\nu = 3$) > ($\nu = 4$) $T_R = 450$ K	IR fluorescence, bulk, He as buffer gas	r
	CF ₂ CH ₂	($\nu = 1$) > ($\nu = 2$) > ($\nu = 3$) > ($\nu = 4$)	IR fluorescence, bulk, He as buffer gas	r
	C ₂ H ₅ F	($\nu = 1$) > ($\nu = 2$) > ($\nu = 3$) at low pressure	IR fluorescence, bulk; reports population inversion at higher pressures	s
	CHF ₂ CH ₂ F	populated to $\nu = 3$	IR fluorescence, bulk; emission from C-H stretch of reactant also seen	t

^a Lesiecki, M. L.; Guillory, W. A. *J. Chem. Phys.* **1978**, *69*, 4572. ^b Ashfold, M. N. R.; Hancock, G.; Hardaker, M. L. *J. Photochem.* **1980**, *14*, 85. ^c Miller, C. M.; Zare, R. N. *Chem. Phys. Lett.* **1980**, *71*, 376. Miller, C. M.; McKillop, J. S.; Zare, R. N. *J. Chem. Phys.* **1982**, *76*, 239. McKillop, J. S.; Gordon, R. J.; Zare, R. N. *J. Chem. Phys.* **1982**, *77*, 2895. ^d Renlund, A. M.; Reisler, H.; Wittig, C. *Chem. Phys. Lett.* **1981**, *78*, 40. ^e Beresford, J. R.; Hancock, G.; MacRobert, A. J.; Catanzarite, J.; Radhakrishnan, G.; Reisler, H.; Wittig, C. *Faraday Disc. Chem. Soc.* **1983**, *75*, 211. ^f King, D. S.; Stephenson, J. C. *Chem. Phys. Lett.* **1977**, *51*, 48. ^g Stephenson, J. C.; King, D. S. *J. Chem. Phys.* **1978**, *69*, 1485. ^h Stephenson, J. C.; King, D. S. *J. Chem. Phys.* **1983**, *78*, 1867. ⁱ Stephenson, J. C.; Bialkowski, S. E.; King, D. S. *J. Chem. Phys.* **1980**, *72*, 1161. ^j King, D. S.; Stephenson, J. C. *J. Chem. Phys.* **1985**, *82*, 2236. ^k Schmiel, R.; Boettner, R.; Zacharias, H.; Meier, U.; Welge, K. H. *J. Mol. Struct.* **1980**, *61*, 271. ^l Feldman, D.; Zacharias, H.; Welge, K. H. *Chem. Phys. Lett.* **1980**, *69*, 466. ^m Hicks, K. W.; Lesiecki, M. L.; Guillory, W. A. *J. Phys. Chem.* **1979**, *83*, 1936. ⁿ Schmiel, R.; Meier, U.; Welge, K. H. *Chem. Phys. Lett.* **1981**, *80*, 495. ^o Yu, M. H.; Levy, M. R.; Wittig, C. *J. Chem. Phys.* **1980**, *72*, 3789. ^p Hall, J. H., Jr.; Lesiecki, M. L.; Guillory, W. A. *J. Chem. Phys.* **1978**, *68*, 2247. ^q Rockney, B. H.; Grant, E. R. *J. Chem. Phys.* **1983**, *79*, 708. ^r Quick, C. R., Jr.; Wittig, C. *J. Chem. Phys.* **1980**, *72*, 1694. ^s Ishikawa, Y.; Arai, S. *Reza Kagaku Kenkyu* **1982**, *4*, 84; *Chem. Abstr.* **1983**, *98*, 135127r. ^t Zellweger, J.-M.; Brown, T. C.; Barker, J. R. *J. Chem. Phys.* **1985**, *83*, 6261. Brown, T. C.; King, K. D.; Zellweger, J.-M.; Barker, J. R. *Ber. Bunsenges. Phys. Chem.* **1985**, *89*, 301.

the LIF probe region. This technique does not allow the measurement of a distribution, which must be assumed to obtain the average translational energy ($\langle E_T \rangle$). Average translational energies from LIF are thus in general less reliable than those obtained from the TOF

mass spec MB technique, although good agreement between the two methods has been reported in some cases^{225,239} (see, however, the discussion of possible pitfalls of the transient migration method by LIF in ref 225).

LIF has the advantage of being able to probe a small part of the IR irradiation region of relatively constant energy density. It is also possible to investigate simultaneously translational and internal energy distributions. King and Stephenson²²⁴ demonstrated in a study of the IRMPD of CH₃ONO in a molecular beam that the fragment translational energy depends on the internal state of the NO fragment, as would be expected.

A refinement of the optical technique to determine translational energies was reported by Welge et al., who have deconvoluted the Doppler profile of LIF excitation spectra to obtain recoil energies.^{226,227} Rockney and Grant²²⁸ have reported the measurement of product translational energy for the IRMPD of CH₃NO₂ via multiphoton ionization of product NO₂ in a molecular beam. Their results are, however, in disagreement with the determination of Wodtke et al.²²⁰

The primary application of optical probing techniques has been the determination of product internal state distributions, which are listed in Table VII. LIF has been the most popular technique to date. Up to now all results seem to be consistent with a statistical approach to URIMIR, although more sophisticated approaches than RRKM theory would really be necessary (see the discussion below). We shall not discuss each example in detail; however, some effects are particularly interesting.

King and Stephenson^{222,223,229,230} studied the internal state distributions of CF₂ produced from IRMPD of a variety of reactants. They found that the distribution depends strongly on the precursor; for example, the rotational temperature T_R varied from 450 K for CF₂ produced from CF₂Br₂ $\omega \sim 2000$ K for the same species from the dissociation of CHClF₂. The case of CF₂Br₂ is a good example to demonstrate some of the complications arising with LIF detection of products. The primary channels for dissociation are CF₂Br + Br and *perhaps* CF₂ + Br₂. However, CF₂ can also be produced by secondary dissociation of the primary product CF₂Br. It is difficult to distinguish the two production routes for CF₂. Furthermore, LIF has extremely high sensitivity for the detection of some products, such as C₂, which is detected in many systems, where it is almost certainly not a primary product, and sometimes even with C₁ haloalkanes, where it clearly must arise from bimolecular reactions following IR photochemistry. In this respect, TOF-molecular-beam detection has a much more balanced sensitivity and thus fewer problems.

The URIMIR of CF₂CClF produced CF₂ and CClF in which ν_2 could not be described by the same vibrational temperature T_v as ν_1 and ν_3 . The intensity dependence of $T_v(\nu_2)$ at constant fluence was studied with square-wave laser pulses (see chapter 5). $T_v(\nu_2)$ increased as intensity was increased from ~ 55 MW cm⁻² to ~ 3.3 GW cm⁻². This is not surprising, in light of the competition at higher intensities between excitation beyond threshold and unimolecular reaction.¹⁰ Intensity effects have also been observed in the product-state distributions of OH²³¹ and C₂.²³²

The CN radical has been investigated after the IRMPD of a number of precursors.²³³⁻²³⁶ Intensity effects have also been reported for this species.^{232,234,235}

IR fluorescence can also be used to probe state distributions of products which have simple IR emission

spectra. In practice this has meant the observation of luminescence from vibrationally excited HF,^{151,237,238} although this technique should also be possible with other products. IR fluorescence does not have the high resolution of LIF, nor can it probe small, uniformly irradiated regions. One is, however, assured of the absence of artifacts arising from IR-visible or IR-UV double excitation which may appear with LIF or MPI.²³⁹ The role of collisions with addition of buffer gas to CHF₂CH₃²³⁷ and the inducing of vibrational population inversion in HF at higher pressures after the IRMPD of C₂H₅F²³⁸ has been discussed. Of course, IR chemiluminescence is particularly sensitive to the secondary effects from collisions, because of the long IR-emission life times.

We conclude this section with a critical discussion of what information can and what cannot be extracted from the measurement of product internal and product translational energy distributions. These distributions depend firstly upon the reactant internal-state distribution before dissociation and thus reflect the dynamics of IR multiphoton excitation. They depend secondly upon the probability that reaction has occurred from a certain energy range of the reactant. By definition and energy conservation this is the total product energy distribution, i.e., the probability that the sum of internal and COM translational energies of the products has a certain value. This total product energy distribution depends upon the competition between optical pumping and the specific rates $k(E, J, \dots)$ for chemical reaction. This distribution is time-dependent until steady state is reached. Thirdly, one has the partial rate for producing a certain product channel p from a given reactant energy and angular momentum state

$$P_p(E, J, \dots) = \frac{k_p(E, J, \dots)}{k(E, J, \dots)} \quad (4.1)$$

It is clear that the measured effects depend in a complicated way upon quite different physical phenomena. The usual procedure has been to compare the experimental results with a simulation making some model assumptions. Agreement between experimental results and the model calculation has then been taken as evidence in favor of the fundamental model assumptions. The most systematic study among many others of this kind has certainly been carried out over the years in the laboratory of Y. T. Lee.^{21,6,213-220} The conclusions were briefly that (a) a linear rate equation model used in the simulation, (b) the $k(E)$ from RRKM theory, and (c) the detailed product formation rates based upon complete internal randomization on the experimental time scale as assumed by RRKM theory were correct because they were in agreement with experimental observations. Some caution is necessary when accepting these conclusions. Firstly, the reactant internal state distribution may be governed by a highly nonlinear case C master equation^{10,13} in contrast to the usual linear rate equation²¹ at low energies and still give the same distributions at high energies relevant for product energy distributions. Secondly, as pointed out in ref 143, the product *translational* energy distributions are strikingly insensitive to the reactant internal state and total product energy distributions as demonstrated in Figure 6 for the case of CF₂Br₂ dissociation to CF₂Br + Br. Thus, the product translational energy

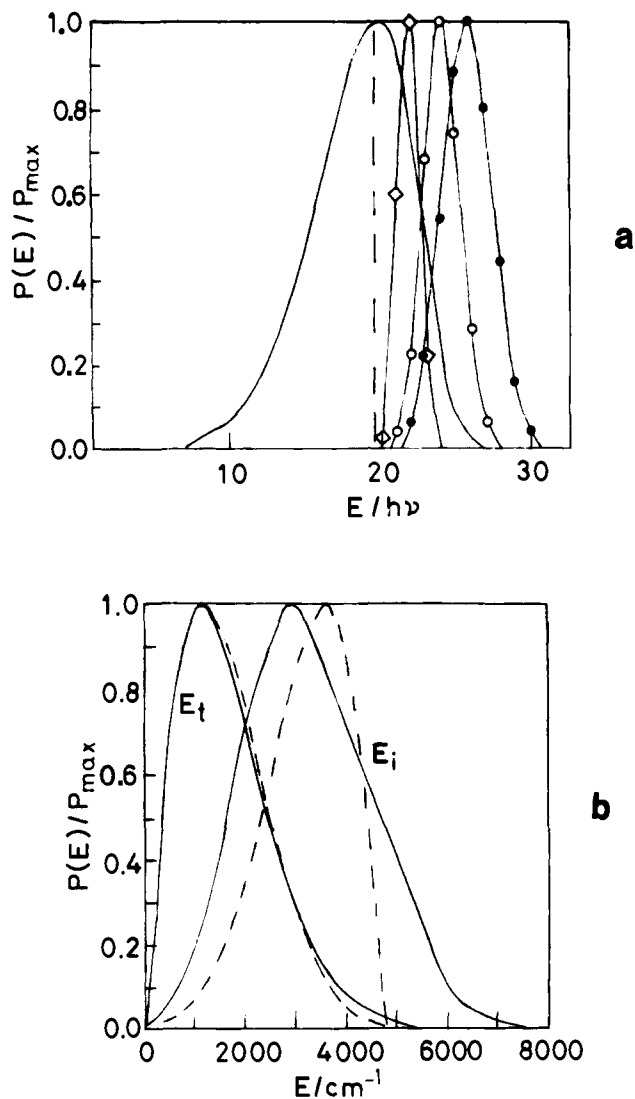

Figure 6. Energy distributions in the IR-photochemical reaction $\text{CF}_2\text{Br}_2 \rightarrow \text{CF}_2\text{Br} + \text{Br}$ (from ref 143). (a) Steady-state distribution for the reactant at a given intensity (full line). The lines with the symbols give total product energy distributions for different intensities, the open circles for the same intensity as the steady state distribution, the diamonds for a factor of ten lower intensity, and the points for a factor of ten higher intensity. (b) Product translational (E_t) and product internal (E_i) energy distributions. The full lines correspond to the proper $P(E)$ from (a) and with a 300 K thermal distribution for $P(J)$, which is an adequate approximation to simulate the angular momentum effects. The dashed lines are obtained by replacing these distributions $P(E)$ and $P(J)$ by their most probable values (i.e., delta functions).

distributions depend mainly on the mean product energy and very little upon distributions created by IR excitation. Thirdly, even the assumption of full or partial internal energy randomization before product formation leaves little definite signature in the calculated results. Although at a given total energy or mean total energy there are clearly visible changes in the product energy distributions depending upon the assumptions on the number of coupled degrees of freedom, these can be easily compensated for by changing the assumed mean total energy, which is *unknown* as discussed above. This is illustrated in Figure 7. Thus, although the extensive molecular beam investigations do contain some indications concerning "statistical" behavior, they do not contain definite proof. In fact, some conclusions and some statements in the experi-

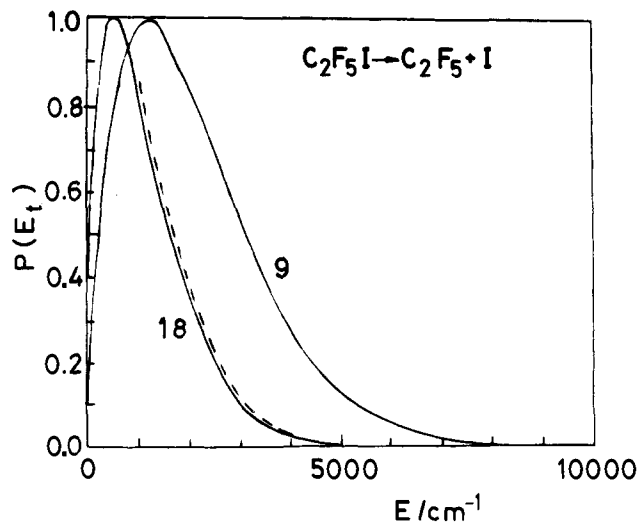
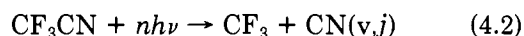

Figure 7. Product translational energy distribution for a 9 and 18 coupled oscillator model of the same reaction $\text{C}_2\text{F}_5\text{I} \rightarrow \text{C}_2\text{F}_5 + \text{I}$ (from ref 143). The distributions are calculated for the same internal energy distributions in the reactant. The dashed line is for a δ function at the average energy, a simplification which has little effect on $P(E_t)$ (see also Figure 6).

mental literature show, how available theoretical knowledge is overlooked, such as in the most recent paper on CH_3NO_2 where one finds²²⁰ that "statistical theory predicts that for simple bond rupture reactions, where no exit barrier exists, the product translational energy distribution of $P(E_T)$ should be a monotonically decreasing function of translational energy peaking toward zero." As is shown in Figures 6 and 7, which show statistical adiabatic channel model calculations for simple bond fission reactions,¹⁴³ such statements have been known to be wrong for more than a decade,¹²⁶⁻¹²⁸ although some popular formulations of RRKM models without proper angular momentum conservation indeed produce such artifacts.^{21,219} If experimental results are in agreement with these incorrect RRKM calculations, this is probably due to uncertainties in the measurement on $P(E_T)$ at very low E_T .

In ref 143 it was concluded that product *internal* state distributions should be more sensitive to details of the dynamics, and also sometimes more useful to test theory. An extremely revealing study in this respect has been published recently on the reaction²³⁶



Due to the usual limitations of the laser-induced fluorescence probing used in this study, only the quantum state (v,j) of the CN fragment could be probed. The experimental distributions could be approximated by Boltzmann distributions with nonuniform temperatures for the various degrees of freedom. Table VIII summarizes the results for these "temperatures" from different experiments and from two theoretical approaches for the calculation of product energy distributions: phase space theory³⁰⁶ (PST) and the adiabatic channel model¹²⁶⁻¹²⁹ (ACM). It is seen that phase space theory is unable to reproduce the relatively large difference in vibrational and rotational temperatures found in the experiments. On the other hand, the adiabatic channel model with a reasonable hindered rotation potential parameter $\alpha = 0.5 \text{ \AA}^{-1}$ comes very close in predicting the experimental findings. We

TABLE VIII. Product Energy Distributions for CN in $\text{CF}_3\text{CN} \rightarrow \text{CF}_3 + \text{CN}$ Characterized by Vibrational (T_v) and Rotational Temperatures (T_r)²³⁶

rule	T_v/K	T_r/K
experiment with multi mode pulse at 1052 cm^{-1}	2400 ± 200	1200 ± 100
single mode pulse at 944 cm^{-1}	1900 ± 300	1240 ± 100
PST	2300	2600
ACM ($\alpha = 0.5\text{ \AA}^{-1}$)	2200	1200

should point out that neither theory, strictly speaking, produces Boltzmann distributions for vibration and rotation, but the non-Boltzmann behavior is too small to be detected in the experiments, presumably because of the partitioning between two fragments, only one of which is detected.

Figure 8 shows an example for non-Boltzmann behavior in product internal-state distributions for the model of Figure 7, where only one fragment carries internal energy. It is to be hoped that in the future more experiments are carried out using more quantitatively refined techniques and the more adequate theoretical simulations with the adiabatic channel model or in simple cases perhaps even quantum dynamical calculations. One may mention in this context also the recent work on product-state distributions in the one-photon vibrational photochemistry of H_2O_2 by Dübäl and Crim.²⁴⁰

4.2. Determination of Absolute Yields and Rate Coefficients for IR Photochemistry

From the point of view of quantitative IR photochemical kinetics the determination of absolute rate parameters is central. Several classes of experiments may be distinguished

(i) In an ideal experiment, one could measure the time dependent concentration of reactants and products as a function of time during or directly after irradiation with laser light of an intensity which is uniform in space and constant in time. This would allow us to measure the rate coefficient

$$k(F, I, t) = -\frac{d \ln F_R}{dt} = -\frac{d \ln [c(t)/c(0)]}{dt} \quad (4.3)$$

This rate coefficient may depend in a nontrivial manner upon the radiation intensity and upon time—with constant intensity fluence is proportional to time. In practice, no such experiment has been reported yet, although recent advances in pulse shaping would seem to make such experiments feasible.²⁴¹⁻²⁴³ Experiments with CW lasers sometimes may belong to this class, but have also certain problems.¹⁸⁴⁻¹⁸⁹

(ii) The next best experiment would be to measure concentrations at a place of well defined fluence in space and time during or directly after irradiation. Very recently, one such experiment has been reported.²⁴⁴ These experiments provide an important quantitative check upon the less ambitious but more abundant experiments of class iii. As shown in^{11,145} and discussed here in section 2, the class ii experiment can be evaluated in terms of the steady-state rate coefficient if the

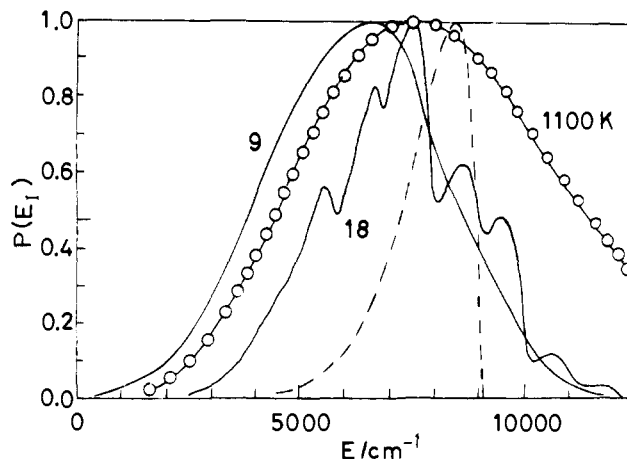

Figure 8. Product internal energy distributions for the models of Figure 7 (from ref 143). The several maxima for the 18-oscillator model result from the laser energy steps in the reactant internal energy distribution; the dashed line indicates the contribution from one such step. A thermal 1100 K distribution for the 18-oscillator model is given as well for comparison. Reproduced with permission from *Intramolecular Dynamics* Jortner, J., Pullmann, B., Ed.; Reidel: Dordrecht, 1982; p 371. Copyright 1982 Reidel.

optical pumping is linear in intensity (case B) and if falloff effects are negligible, by means of the relation

$$k_I(st) = k_{(st)}/I = \lim_{F \rightarrow \infty} \left(-\frac{d \ln F_R}{dF} \right) \quad (4.4)$$

It can be shown^{11,12} that equivalently one could also measure the remaining reactant fraction F_R^* long after the irradiation, which then includes all post pulse dissociation, in the absence of collisional effects:

$$k_I(st) = \lim_{F \rightarrow \infty} \left(-\frac{d \ln F_R}{dF} \right) = \lim_{\substack{F \rightarrow \infty \\ t \rightarrow \infty}} \left(-\frac{d \ln F_R^*}{dF} \right) \quad (4.5)$$

This perhaps surprising point has been first proven in ref 145 and is illustrated by Figure 9, which is the logarithmic reactant fluence plot corresponding to eq 4.4 and 4.5.

(iii) The third type of experiment measures F_R^* (or the corresponding concentrations of reactants and products) as a function of irradiation with pulses of different energy and well-defined, smooth spatial fluence distribution (for instance a Gaussian beam or something similarly well-defined). With this method some evaluation procedure must be used to take the spatial fluence profile into account. Several such procedures have been proposed and one of them allows directly the evaluation of $k(st)$.²⁴⁵

(iv) The fourth type of experiment provides yields F_R^* calculated for a nominal irradiated volume and fluence which is calculated from an approximate laser beam cross section with parallel irradiation but otherwise ill defined fluence distribution. Many experiments with multimode lasers and the familiar "square hat" fluence profile are of this kind, because the fluence distribution in this square of a multimode laser output contains uncontrolled fluence variations. Still, these experiments can be evaluated at least approximately, if the average radiation parameters are properly reported. Sometimes, they seem to provide relatively reasonable rate parameters, even without taking details of the fluence profile into account (see Table IX).

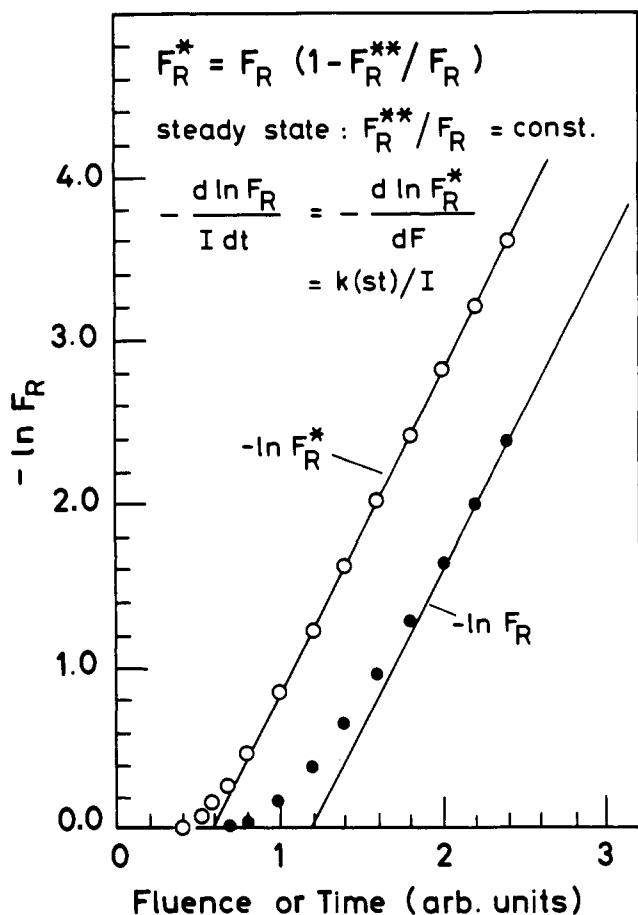

Figure 9. Logarithmic reactant fluence plot for a theoretical model reaction illustrating the two-yield functions $-\ln F_R$ and $-\ln F_R^*$, which differ by the after pulse reaction (see the detailed discussion in the text and eq 4.4 and 4.5).

(v) The final and last class of experiments either reports no quantitative radiation parameters or uses ill-defined focused geometries, giving apparent yields as a function of "pulse energy" or related properties of the laser. These experiments cannot even approximately be evaluated in terms of absolute yields or rate parameters. It may be noted that most of the experiments providing relative rate parameters discussed in section 4.1 are of this kind.

Table IX summarizes rate constants evaluated from literature data falling into class ii to iv experiments. We have avoided providing a detailed classification for each experiment. But in summary we note that there is just one of class ii, there are about five of class iii, and the rest belong to class iv—sometimes with a tendency towards class v experiments. From this summary it is clear that this table should not create the impression that the individual numbers are definite rate parameters. Rather, we wish to indicate that at least some start has been made towards quantitative IR photochemistry and that there is hope that the situation will improve in the future. We shall now give a brief discussion of the problems of data evaluation and then discuss one example in more detail, for which there is a relatively large amount of data (CF_3I).

The first task in quantitative IR photochemistry is to provide well-defined radiation parameters in terms of a smooth, reproducible beam profile. Experimentally this is achieved easily by either restricting the output coupler of a stable resonator to a small circle, such that

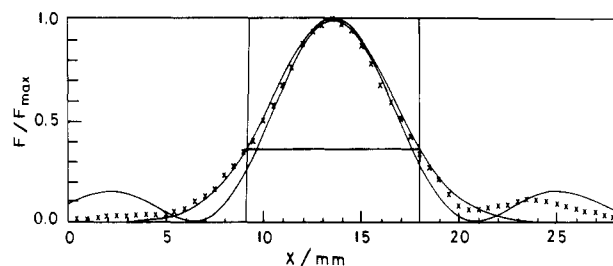

Figure 10. Typical experimental fluence beam profile measured along a line across a laser beam from a CO_2 laser with unstable resonator optics. The wings can be diffracted out by apertures, if necessary, resulting in essentially Gaussian beams (see the full line). The second full line with large wings is from another Bessel-type theoretical function. Reproduced with permission from *J. Chem. Phys.* 1982, 76, 955. Copyright 1982 American Institute of Physics.

only oscillation on TEM_{00} is possible²⁴⁷ or by use of unstable resonator optics, which has a high transverse mode discrimination combined with an efficient use of the active laser volume.²⁴⁵ Figure 10 shows a typical experimental beam cross section together with the theoretical Gaussian and Bessel type functions. In the evaluation one has to take the fluence distribution into account.²⁴⁵⁻²⁵¹ One can distinguish broadly three different approaches:

(a) One uses an analytical closed-form expression for deconvolution with special beam profiles. Kolodner et al.²⁴⁶ have used such a method for Gaussian beams with a fluence distribution

$$F = F_0 \exp[-2r^2/W_0^2] \quad (4.6)$$

with the distance, r , from the beam center, the nominal beam width W_0 and the nominal fluence F_0 . One can relate any measured function $G(F_0)$ to the true function $G'(F)$.^{246,247}

$$G'(F) = F \left(\frac{dG(F_0)}{dF_0} \right)_{F_0 = F} \quad (4.7)$$

One thus needs accurate values for the derivative dG/dF in the experimental function. In practice, this is not available to sufficient accuracy and thus this direct method turns out to be less useful, quite apart from the restriction to Gaussian beams. One might, however, combine it with either of the following.

(b) One may use a polynomial Taylor expansion for the function to be evaluated and convolute this with the beam profile, obtaining the expansion coefficients from a least-squares fit. For instance, Francisco et al.²⁵¹ have proposed this method and used

$$G(F) = \sum_{n=l}^{n_{\max}} a_n F^n \quad (4.8)$$

in a study of the IR photochemistry of $\text{C}_2\text{H}_5\text{Cl}$ ²⁵² with focused geometry. Unfortunately, they did not present their end result for $G(F)$ so that we could not evaluate the rate parameters from their data. However, systematic tests with model functions indicate that with typical experimental scatter the use of a polynomial for fitting gives unreliable results because of the instability of such a many parameter expansion.^{245,307}

(c) The third approach uses a theoretical function for the fluence-dependent yield and fits the (few) parameters in this function of the experimental results, taking

TABLE IX. Experimental Rate Coefficients for URIMIR

reaction	$[k(st)/s^{-1}]/$ $[I/MW\text{ cm}^{-2}]$	conditions	ref
SF ₆ → SF ₅ + F	1.0 × 10 ⁵	bulk near 300 K (944 cm ⁻¹)	a
	0.84 × 10 ⁵	bulk 223 K (944 cm ⁻¹)	b
	0.68 × 10 ⁵	bulk 293 K (944 cm ⁻¹)	
	0.49 × 10 ⁵	bulk 243 K (944 cm ⁻¹)	
	(2 ± 1) × 10 ⁵	beam 150 K (948 cm ⁻¹)	c
(CF ₃) ₂ CO → products	3.3 × 10 ⁵	bulk	d
CF ₃ I → CF ₃ + I	1.1 × 10 ⁵	bulk (1075 cm ⁻¹)	e
	4.0 × 10 ⁵	VLPΦ (1076 cm ⁻¹)	f
	7.8 × 10 ⁵	bulk (1075 cm ⁻¹)	g
	6.5 × 10 ⁵	bulk (1075 cm ⁻¹)	h
	3.3 × 10 ⁵	bulk (1078 cm ⁻¹)	h
	2.0 × 10 ⁵	bulk (1075 cm ⁻¹)	cc
	1.6 × 10 ⁶	bulk (1075 cm ⁻¹)	i
	1.3 × 10 ⁶	Bulk, MPI (1075 cm ⁻¹)	dd
CF ₃ Br → CF ₃ + Br	0.9 × 10 ⁶	Bulk (1082 cm ⁻¹)	ee
C ₂ F ₄ S ₂ → 2CF ₂ S	2.3 × 10 ⁶	bulk (1076 cm ⁻¹)	j
	3.2 × 10 ⁶	bulk (1076 cm ⁻¹)	k
	7.9 × 10 ⁵	bulk (955 cm ⁻¹)	
c-C ₄ F ₈ → 2C ₂ F ₄	2.0 × 10 ⁶	bulk	l
N ₂ F ₄ → 2NF ₂	1.0 × 10 ⁶	bulk	m
UO ₂ (HFACAC) ₂ THF → UO ₂ (HFACAC) ₂ + THF	1.5 × 10 ⁷	bulk	n
CCl ₃ F → CCl ₂ F + HCl	5.1 × 10 ⁵	bulk	o
C ₂ HCl ₂ F ₃ → C ₂ ClF ₃ + HCl	1.4 × 10 ⁶	bulk	p
CHCl ₂ F → CClF + HCl	2.5 × 10 ⁵	bulk	q
CDCl ₂ F → CClF + DCl	2.3 × 10 ⁵	bulk (1075 cm ⁻¹)	q
	2.1 × 10 ⁵	bulk (944 cm ⁻¹)	
C ₃ F ₇ I → C ₃ F ₇ + I	6.3 × 10 ⁵	bulk	cc
i-C ₃ F ₇ I → C ₃ F ₇ + I	6.4 × 10 ⁵	bulk, MPI	dd
n-C ₃ F ₇ I → C ₃ F ₇ + I	6.0 × 10 ⁵	bulk, MPI	dd
CHDF(CH ₂) ₂ CHF →	2.3 × 10 ⁵	bulk (978 and 933 cm ⁻¹)	r
(a) HF + CHDFCH ₂ CH=CH ₂			
(b) HF + CHD=CHCH ₂ CH ₂ F			
CH ₂ F(CH ₂) ₂ CH ₃ → HF + CH ₂ =CCHCH ₂ CH ₂ F	1.7 × 10 ⁵	bulk	r
CHDF(CH ₂) ₂ CH ₃ → HF + CHD=CHCH ₂ CH ₃	1.4 × 10 ⁵	bulk	r
CH ₂ F(CH ₂) ₂ CH ₃ → HF + CH ₂ =CHCH ₂ CH ₃	1.0 × 10 ⁵	bulk	r
CH ₃ (CO) ₂ CH ₂ CH ₃ → CH ₃ CO ₂ H + CH ₂ =CH ₂	6.2 × 10 ⁵	bulk	s
CH ₂ F(CO) ₂ CH ₂ CH ₃ → CH ₂ FCO ₂ H + CH ₂ =CH ₂	2.0 × 10 ⁵	bulk	s
CF ₃ CH ₂ Cl → products	3.1 × 10 ⁵	bulk	t
CHF ₂ CH ₂ F → HF + C ₂ H ₂ F ₂	2.5 × 10 ⁵	VLPΦ	u
(CH ₃ OH) ₂ H ⁺ → products	6.9 × 10 ⁵	CW, QUISTOR, 321 K	v
	4.6 × 10 ⁵	CW, QUISTOR, 293 K	
[(CH ₃) ₂ CHOH] ₂ H ⁺ → (CH ₃) ₂ CHOH ⁺ + H ₂ O	6.9 × 10 ⁵	CW, QUISTOR, 293 K	v
CH ₃ OH ⁺ → CH ₃ OH + F ⁻	5.2 × 10 ⁴	ICR, pulsed, 1072 cm ⁻¹	w
	1.7 × 10 ⁴	939 cm ⁻¹	
[(C ₂ H ₅) ₂ O] ₂ H ⁺ → (C ₂ H ₅) ₂ OH ⁺ + (C ₂ H ₅) ₂ O	5.4 × 10 ⁶	ICR, pulsed	x
	1.1 × 10 ⁶	ICR, CW	y
C ₃ F ₆ ⁺ → C ₂ F ₄ ⁺ + CF ₂	2.4 × 10 ⁶	ICR, pulsed	z
(C ₂ H ₅) ₂ OH ⁺ → C ₂ H ₅ OH ₂ ⁺ + C ₂ H ₄	5.3 × 10 ⁴	ICR, CW	aa
CF ₃ I ⁺ → CF ₃ ⁺ + I	8.0 × 10 ⁵	ICR	bb

^a Campbell, J. D.; Hancock, G.; Welge, K. H. *Chem. Phys. Lett.* **1976**, *43*, 581. ^b Duperrex, R.; van den Bergh, H. *Chem. Phys.* **1979**, *40*, 275. Duperrex, R.; van den Bergh, H. *J. Chem. Phys.* **1979**, *70*, 5672. ^c Brunner, F.; Proch, D. *J. Chem. Phys.* **1978**, *68*, 4936. See also: Quack, M. *Ber. Bunsenges. Phys. Chem.* **1979**, *83*, 757. ^d Fuß, W.; Kompa, K. L.; Tablas, F. M. G. *Faraday Discuss. Chem. Soc.* **1979**, *67*, 180. See also: Luther, K.; Quack, M. *Ibid.* **1979**, *67*, 229. ^e Bittenson, S.; Houston, P. L. *J. Chem. Phys.* **1977**, *67*, 4819. ^f Golden, D. M.; Rossi, M. J.; Baldwin, A. C.; Barker, J. R. *Acc. Chem. Res.* **1981**, *14*, 56. ^g Bagratashvili, V. N.; Doljikov, V. S.; Letokhov, V. S.; Ryabov, E. A. *Laser Induced Processes in Molecules*; Kompa, K. L.; Smith, S. D., Eds.; Springer Verlag: Berlin, 1979; p 179. ^h Bagratashvili, V. N.; Ionov, S. I.; Kuzmin, M. F.; Mishakov, G. V. *Chem. Phys. Lett.* **1985**, *115*, 149. ⁱ Quack, M.; Seyfang, G. *J. Chem. Phys.* **1982**, *76*, 955. ^j Plum, C. N.; Houston, P. L. *Chem. Phys.* **1980**, *45*, 159. ^k Quack, M.; Seyfang, G. *Chem. Phys. Lett.* **1981**, *84*, 541. ^l Quack, M.; Seyfang, G. *Ber. Bunsenges. Phys. Chem.* **1982**, *86*, 504. ^m Kleinermanns, C.; Wagner, H. G. *Z. Phys. Chem. (Munich)* **1979**, *118*, 1. ⁿ Kaldor, A.; Hall, R. B.; Cox, D. M.; Horsley, J. A.; Rabinowitz, P.; Kramer, G. M. *J. Am. Chem. Soc.* **1979**, *101*, 4465. ^o Lupo, D.; Quack, M. *Chem. Phys. Lett.* **1986**, *130*, 371. ^p Lupo, D.; Quack, M.; Vogelsanger, B. *Helv. Chim. Acta*, in press. In addition to the primary elimination of HCl, evidence for smaller amounts of HF and Cl₂ was observed. ^q Gozel, P.; van den Bergh, H.; Lupo, D.; Quack, M.; Seyfang, G., manuscript in preparation. ^r Quack, M.; Thöne, H. *Faraday Discuss. Chem. Soc.*, in press. The two channels for 1,4-difluoro-1-deuterobutane occurred in approximately equal proportions for pumping of both the C-F (978 cm⁻¹) and C-D (933 cm⁻¹) vibrations. ^s Danen, W. C.; Rio, V. C.; Setser, D. W. *J. Am. Chem. Soc.* **1982**, *104*, 5431. ^t Setser, D. W.; Lee, T.-S.; Danen, W. C.; *J. Phys. Chem.* **1985**, *89*, 5799. ^u Zellweger, J.-M.; Brown, T. C.; Barker, J. R. *J. Chem. Phys.* **1985**, *83*, 6251. ^v Young, B.; March, R. E.; Hughes, R. J. *Can. J. Chem.* **1985**, *63*, 2332. Lowest pressure (10⁻⁴-10⁻³ Pa) results from CW irradiation of ions in a quadrupole ion store (QUISTOR). ^w Rosenfeld, R. N.; Jasinski, J. M.; Brauman, J. I. *Chem. Phys. Lett.* **1980**, *71*, 406. ^x Rosenfeld, R. N.; Jasinski, J. M.; Brauman, J. I. *J. Am. Chem. Soc.* **1982**, *104*, 658. ^y Woodin, R. L.; Bomse, D. S.; Beauchamp, J. L.; *J. Am. Chem. Soc.* **1978**, *100*, 3248. ^z Jasinski, J. M.; Rosenfeld, R. N.; Meyer, F. K.; Brauman, J. I. *J. Am. Chem. Soc.* **1982**, *104*, 652. ^{aa} Bomse, D. S.; Woodin, R. L.; Beauchamp, J. L. *J. Am. Chem. Soc.* **1979**, *101*, 5503. ^{bb} Thorne, L. R.; Beauchamp, J. L. *J. Chem. Phys.* **1981**, *74*, 5100. ^{cc} Simpson, T. B.; Black, J. G.; Burak, I.; Yablonovitch, E.; Bloembergen, N. *J. Chem. Phys.* **1985**, *83*, 628. ^{dd} Quack, M.; Sutcliffe, E.; Hackett, P.; Rayner, D. *Faraday Discuss. Chem. Soc.*, in press. Hackett, P.; Rayner, D.; Quack, M.; Sutcliffe, E. *J. Chem. Phys.*, manuscript in preparation. The appearance of I atoms was monitored in real time via multiphoton ionization. ^{ee} Kühne, R. O.; Quack, M., manuscript in preparation.

the spatial fluence profile into account quantitatively.²⁴⁵ This approach is certainly preferable, but has the obvious drawback that systematic errors may be introduced if the theoretical function is not really adequate. A function which results from an irreducible case B master equation is of the following type:^{10,12}

$$F_R^* = \sum_k \phi_k^* \exp(\kappa_k F) \quad (4.9)$$

This function has been used in practice with one or two terms of the sum. For a reducible case B situation,^{10,11} eq 4.9 has to be replaced by a weighted sum of such terms for each irreducible subset. In case C, fluence is not sufficient to characterize the yield function, which also depends upon intensity. Another equation that has been used results from the two parameter activation equation for the rate coefficient:^{11,12}

$$F_R^* = \exp\left\{-k_I(st) \int_0^F \exp[-(\varphi/x)^2] dx\right\} \quad (4.10)$$

Both of these equations can be directly evaluated in terms of the steady-state rate coefficient and the results should, in principle, be good for substantial yields ($F_P^* = 1 - F_R^* > 10^{-3}$, at least for eq 4.10 and larger for eq 4.9 with at least two terms). Figure 11 illustrates the procedure with a theoretical model calculation.^{29,245} Both equations should also be satisfactory for measurements in the nonlinear régime, if the intensity of the pulses is constant. However, no experimental evaluations of this kind have been reported. Another equation for the product yield is Barker's log normal distribution:¹⁴⁶

$$F_P^* (\ln F) = \int_{x=-\infty}^{x=\ln F} \frac{1}{\sigma \sqrt{2\pi}} \exp\left\{-\frac{(x - \mu)^2}{2\sigma^2}\right\} dx \quad (4.11)$$

This function is reasonably successful for a case B master equation and small values of F_P^* , far from steady state. At steady state it gives the wrong limit ($k(t \rightarrow \infty) = 0$ for the log normal distribution). It can also be shown that it provides a poor representation for case C master equations.^{13,307} This does not invalidate applications of this equation to case B and situations with small or intermediate yields. It must be pointed out that in practice also the theoretically more satisfactory equations 4.9 and 4.10 may have problems, such as instabilities in the fitting procedures due to the generally large experimental scatter. Also the rate coefficients from the two equations tend to be often systematically different, although they should not be different in the rigorous limit. From our experience, even with good data, rate coefficients can be evaluated absolutely only to within a factor of two.²⁴⁵ Most of the data in Table IX are even much less reliable. A practically interesting observation is the fact that for small molecules relatively high inert gas pressures introduce case B behavior and still allow one to evaluate the "collisionless" $k(st)$.²⁴⁵ Some of the data in Table IX have been obtained in this way. However, the detailed theoretical justification for the empirical observation has not yet been given, and the general applicability of the method remains uncertain. One should thus take these results only as a first estimate and accept as definite only those results where the absence of appreciable nonlinear intensity effects and collisional

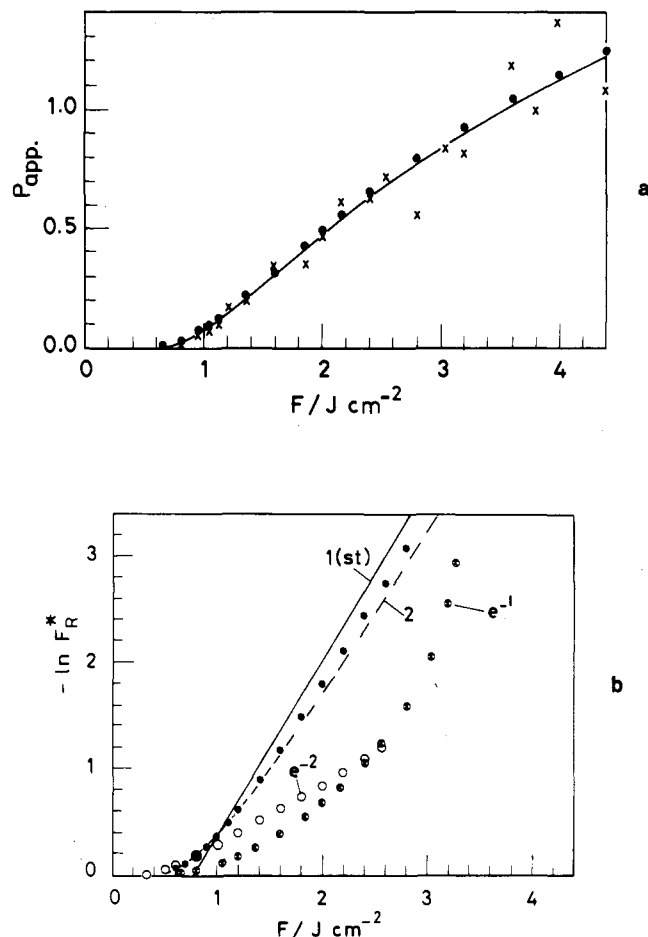
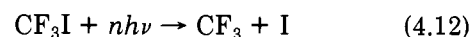

Figure 11. Theoretical simulation of the procedure for obtaining the steady state rate coefficient and the real yield function $-\ln F_R^*$ from a measured apparent yield P_{app} as a function of nominal fluence. (a) Apparent yield. The points are the exact results for a theoretical model of CF_3I IR photolysis. The crosses are the model results with "experimental scatter" added from a random number table. (b) Yield function $-\ln F_R^*$ derived from the exact model results (points) and various approximations in the evaluation of the apparent yield. The full line is for just one exponential term in eq 4.9 and the dashed line for two exponential terms in eq 4.9. One sees that both evaluations are good approximations to the "truth" (points) even though they are obtained from fits to realistically scattered "experimental" data points. The e^{-1} and e^{-2} functions are from $P_{app} = F_P^*$ with fluence calculated formally for a rectangular beam shape with e^{-1} and e^{-2} cut off, which are often used but both poor approximations. Reproduced with permission from *Chimia* 1981, 35, 463. Copyright 1981 Chimia-Abodienst.

effects has been proven by experiments.^{245,254,308} The above discussion renders the necessity of more direct, absolute measurements of types i and ii obvious, which can be used as a check for the indirect measurements of type iii with convolution or deconvolution. We shall conclude this section with the example of the IR photochemical reaction



For this example, more or less quantitative data are particularly abundant in Table IX. The rate coefficients range over more than a factor of ten and these discrepancies are not in the first place due to, say, the obvious frequency dependence, although several different laser lines near the maximum efficiency have been used. Rather, the difficulty with most data is that either the chemistry was not fully controlled (i.e., the

TABLE X. Summary of Parameter Values for Approximate Expressions for the Case B Steady-State Limit of the Rate Coefficient ($k(st)/s^{-1}/(I'G'\Delta\tilde{\nu}^{-1})$), Where $I' = I/\text{MW cm}^{-2}$, $G' = G/\text{pm}^2$, $\Delta\tilde{\nu}' = \Delta\tilde{\nu}/1000 \text{ cm}^{-1}$ (for simple bond fission reactions)

eq no.	(4.15)	(4.16)		
		(i)	(ii)	(iii)
α	6.44×10^6	4.15×10^6	3.37×10^6	6.34×10^6
a	1.69	1.36	1.03	1.63
b	2.19	2.10	2.05	2.18
c	2.89	2.57	2.32	2.85
A		0.49	-	-
A_1				0.19

^aThe threshold and zero point energies and excitation quantum were given in the reduced forms $E_{T'} = E_T/hc1000 \text{ cm}^{-1}$, $E_{Z'} = E_Z/hc1000 \text{ cm}^{-1}$, and $\tilde{\nu}_1 = \tilde{\nu}_1/1000 \text{ cm}^{-1}$.

yields reported were not really close to primary photochemical yields) or the radiation parameters intensity and fluence were not controlled. In one study, both effects and in addition the effect of collisions were investigated. This study gave the highest value reported in Table IX. Checks on the intrinsic intensity dependence with near resonance pumping indicated a sufficiently small nonlinearity in intensity to validate the case B evaluation of rate coefficients,^{245,254} although off resonance there was a marked nonlinearity. Most recent direct, time resolved measurements of the iodine atom yield for reaction 4.12 give results in excellent agreement with the indirect method.²⁴⁴ Furthermore, it could be shown that indeed the yield is only fluence dependent at high pulse intensities, whereas a nonlinear intensity dependence becomes important at low intensities, in very good qualitative agreement with the theoretical expectation for the transition from case B to case C at low intensities. So it appears that for this convenient model system real progress (although not a "final" result²⁴⁴) has been achieved over the years, excluding one most recent paper, which gave a low value for yields and rate coefficients.²⁵⁵ The origin of the discrepancies is difficult to trace as the authors of this paper did not discuss them and did not compare their results to previous, careful studies.

4.3. Estimation of Absolute Rate Coefficients

The obvious first questions of the practicing IR-laser chemist are for a given reactant: (a) Qualitatively, what will be the distribution over various reaction products? (b) Quantitatively, how fast will the reaction be?

The common current answer to the first question is that product distributions can be estimated ordinarily by statistical unimolecular rate theory in its various forms,^{253,305} taking properly into account that the reactant-state distributions created by IR-multiphoton excitation are very different from thermal distributions.¹⁰⁻¹³ Of course, in special situations special effects such as mode or group selectivity may have to be taken into account.

The second question has, to our knowledge, been addressed theoretically only in one series of papers.¹⁰⁻¹³ If one wishes to take into account nonlinearities, spectral detail, etc., there is no simple answer to this question. For the case B master equation with optimum frequency selection, however, some strikingly simple rules have been proposed.¹² We shall in this section summarize the results from some semiempirical

extensions of these rules, concentrating on the steady state rate coefficient. Other activation parameters are important, as well, but we refer to the literature for a discussion of these.¹⁰⁻¹³

For the reaction threshold bottleneck rate coefficient in case B with a semiclassical approximation for the density of states one derives¹²

$$k_{\text{RTB}} = C\Delta\tilde{\nu}^{-1}GI \frac{s(s-1)\tilde{\nu}_1^2}{(E_T + E_Z)^2} \quad (4.13)$$

Here, C is a universal constant (with appropriate dimensions); $\Delta\tilde{\nu}$, a bandwidth parameter for the pumped absorption band ($\Delta\tilde{\nu} < \tilde{\nu}_1$), with fundamental frequency $\tilde{\nu}_1$. G is the integrated infrared absorption cross section σ for this fundamental, which is assumed to be isolated or dominant in absorption

$$G = \int_{\text{band}} \sigma(\tilde{\nu}) \frac{d\tilde{\nu}}{\tilde{\nu}} \quad (4.14)$$

I is the radiation intensity, s the number of vibrational (including torsional or internal rotational) degrees of freedom, E_T is the threshold energy for reaction, which is usually close to the Arrhenius activation energy for the high pressure limit of the thermal unimolecular reaction, and E_Z is the total zero point energy of the reactant ($= 0.5\sum_i h\nu_i$ for harmonic oscillators). Equation 4.13 can be generalized in a practical, improved form^{12,61}

$$k(st) = \alpha'(I'G'\Delta\tilde{\nu}'^{-1})s^a \tilde{\nu}_1'^b (E_{T'} + E_{Z'})^{-c} \quad (4.15)$$

Here we have used the dimensionless variables such as $I' = I/\text{MW cm}^{-2}$, $G' = G/(\text{pm})^2$, etc. Equation 4.15 has four parameters, which are summarized in Table X. They were adjusted to a series of exact solutions of the case B master equation for a number of molecules.^{12,309} When one notes that the dominant factor $E_T + E_Z$ arises from the semiclassical approximation for the density of states, used in the derivation of eq 4.13 and 4.15, one has two further improved representations by using either the semiempirical Whitten-Rabinovitch²⁵⁶ or the analytical Haarhoff correction for the density of states:²⁵⁷

$$k(st) = \alpha'(I'G'\Delta\tilde{\nu}'^{-1})s^a \tilde{\nu}_1'^b (E_{T'} + AE_{Z'})^{-c} \quad (4.16)$$

A is either adjusted or calculated with the Whitten-Rabinovitch equations. When one uses the Haarhoff expressions, one has

$$A_1 = \frac{(s-1)(s-2)}{6s} \alpha_2 \quad (4.17)$$

$$A_2 = \frac{(s-1)(s-2)(s-3)(s-4)}{360s^2} \left(5\alpha_2^2 + \frac{2\alpha_4}{s} \right) \quad (4.18)$$

$$\alpha_m = \frac{\langle \tilde{\nu}^m \rangle}{\langle \tilde{\nu} \rangle^m} \quad (4.19)$$

$$k_{st} = \alpha'(I'G'\Delta\tilde{\nu}'^{-1})s^a \tilde{\nu}_1'^b f(E_{T'} + E_{Z'}) \quad (4.20)$$

$$f(E_{T'} + E_{Z'}) = \left\{ (E_{T'} + E_{Z'}) \times \left(1 - A_1 \left(\frac{E_{Z'}}{E_{T'} + E_{Z'}} \right)^2 + A_2 \left(\frac{E_{Z'}}{E_{T'} + E_{Z'}} \right)^4 + \dots \right) \right\}^{-c} \quad (4.21)$$

Again, A_1 can be either evaluated from the Haarhoff equations or taken to be adjustable. More generally, one can also correct the semiclassical density of states by using a correction function in the second parenthesis of eq 4.21, which is obtained with directly counted densities of states.^{258,131}

The philosophy of the above expressions is to allow a simple, quick estimate of the optimum case B rate coefficient for IR photochemical reactions. With the constants in Table X this calculation can be performed on a pocket calculator in a few minutes. Particularly for the simpler expressions only easily accessible molecular parameters are needed. Of course, exact solutions of the master equation are not too difficult either.^{10,11} We may mention also a further expression derived and tested by Troe¹⁵² on the basis of the results given previously in ref 11 and 12. This expression includes intensity falloff

$$k(st) = \alpha'(I'G'\Delta\tilde{\nu}^{-1})s \ln\left(\frac{b}{\alpha'I'G'\Delta\tilde{\nu}^{-1}}\right) \frac{1}{0.01\left(\frac{E_T'}{\tilde{\nu}_1'}\right)^3 + s\left(\frac{E_T'}{\tilde{\nu}_1}\right)} \quad (4.22a)$$

In the linear limit this reduces to

$$k(st) = \alpha'(I'G'\Delta\tilde{\nu}^{-1})s \frac{1}{0.01(E_T'/\tilde{\nu}_1')^3 + s(E_T'/\tilde{\nu}_1')} \quad (4.22b)$$

We have tested these expressions, but even with optimum adjustment, they provide a less satisfactory representation than eq 4.15 and 4.16.

The approximate equations contain a number of parameters which have different significance and value in the various equations, although we have used the same symbols. The values have been specified in Table X, with the exception of $\Delta\tilde{\nu}$. Taking $\Delta\tilde{\nu} = \tilde{\nu}_1$ should provide a low estimate. In ref 29 it has been suggested on the basis of the limited empirical evidence then available, that $\tilde{\nu}_1/\Delta\tilde{\nu} \approx 4$ should provide a rough estimate of the actual rate coefficient. More data are needed to provide more experimental constraints upon such crude estimates. The limitations and extensions of the estimates are discussed in detail in ref 309.

4.4. Radiative and Collisional Energy Transfer as Investigated by the Measurement of Internal-State Distributions

The internal state distributions created by IR multiphoton excitation and evolving in the course of reaction, possibly including collisions, are central for our understanding of IR photochemistry. They are very clearly also important for practical aspects of the process. Nevertheless, it remains true, as stated in a review 5 years ago,³⁰ that only qualitative or incomplete results on internal state distributions are available, very much as in the early measurements by Sudbo et al.³⁰² Some progress has been made, though, in recent years on measurements of *average* energies after multiphoton excitation and their evolution under collisional relaxation. Although no coherent picture has, as yet, emerged out of these studies, we shall provide here a brief summary of the more recent work.

Steinfeld et al.²⁵⁹⁻²⁶¹ have used IR spectroscopy to study level populations and collisional energy transfer in the lower vibrational states of SF₆,²⁵⁹ CH₄,²⁶⁰ and CDF₃.²⁶¹ after IR-one- and multiphoton excitation. The excitation intensities were in the kW cm⁻² range and thus a few orders of magnitude below the typical IR photochemical intensities.

UV spectroscopy has been used to study highly excited levels in CF₃I.²⁶²⁻²⁶⁴ Pummer et al.²⁶² observed broadening of UV absorption when CF₃I was irradiated with 9.6 μm CO₂-laser radiation. Padrick et al.²⁶³ and Fuss²⁶⁴ used flash UV spectroscopy to probe the effects of CO₂-laser excitation in CF₃I. In this context the attempt of Bagratashvili et al.²⁶⁵ to derive an average absorption cross section for CF₃I molecules near the threshold for dissociation, by using a technique based on ref 11, deserves mentioning. Attempts have been made to use Raman spectroscopy to probe the highly excited molecules SF₆,^{266,267} CF₃I,²⁶⁶ CHCl₂F, and CBrF₃.²⁶⁹ In none of these studies was it possible to derive any definite results on internal state distributions.

The Raman probing experiment of Mazur et al.²⁶⁷ was interpreted in terms of a coupling in SF₆, which mixes Raman and IR-active modes of different symmetry, which may seem surprising to some. One may note, however, that the observation of such couplings has a long history with the early discovery of the Fermi-resonance²⁶⁸ in the CO₂ symmetric stretching fundamental, which makes the bending overtone Raman-allowed at very low energies, indeed, and is also the basis of the two vibrational transitions in the CO₂ laser. It must be stressed, that rigorous spectroscopic selection rules refer to rovibronic *states* and not to vibrational modes, which are often coupled due to a variety of rovibronic couplings. The spectrum of SF₆ is not yet understood to a sufficient degree to allow for definite conclusions. Mazur et al.²⁶⁷ have proposed that their results are evidence for a bimodal energy distribution. Such a bimodal distribution is in agreement with the general theory of ref 10-13, on which basis it was first predicted in quantitative calculations. At present, the experimental evidence in this context remains ambiguous. In the context of internal state distributions one may also mention the relationship to multiphoton absorption without reaction, for which simple models have been proposed,²⁷⁵ which presumably need some revision, if bimodal distributions become more firmly established.

The role of collisions in still truly IR photochemical reactions has been recognized since the early work of Fuss and Cotter,²⁴⁹ Houston,³⁰³ and of van den Bergh and co-workers.³⁰⁴ More recently, efforts have been undertaken to determine collisional relaxation rates of molecules after IR-laser excitation, to determine average energies transferred per collision and even their energy dependence. Kudriavtsev and Letokhov²⁷⁰ and Herzog et al.²⁷¹ have used transient UV absorption spectroscopy to study energy transfer in highly excited molecules after CO₂ laser excitation. Kudriavtsev and Letokhov studied vibrational energy transfer in excited CF₃I by monitoring the time dependence of absorption of light from XeCl and N₂ lasers after a pulse from a CO₂ laser and reported an energy-transfer rate coefficient of $(2.0 \pm 0.4) \times 10^6 \text{ s}^{-1} \text{ Torr}^{-1}$. Unfortunately, the dependence of this rate on fluence, thus on level of excitation, was not studied. Recently Herzog et al.²⁷¹ have studied the

excitation fluence dependence of collisional deactivation of fluoroethylcycloheptatriene with UV absorption spectroscopy using a Xe-Hg arc lamp. They reported the average energy transferred per collision with propane as $\langle \Delta E \rangle = -(500 \pm 200) \text{ cm}^{-1}$. They did not observe a dependence on excitation energy. We mention here as well the work of Gordon et al.,²⁷² who have used the photoacoustic technique to study IR multiphoton excitation of *cis*-3,4-dichlorobutene in Ar and vibrational relaxation of several molecules in Ar.

An elegant investigation of vibrational deactivation after multiphoton excitation has been reported by Zellweger et al.^{273,151} The average vibrational energy content $\langle E \rangle$ of $\text{CHF}_2\text{CH}_2\text{F}$ was determined from the intensity of IR fluorescence from the C-H stretching region.¹⁵¹ From the fluence dependence of energy transfer they reported a weakly $\langle E \rangle$ -dependent value for $\langle \Delta E \rangle_d$, the average energy lost per deactivating collision (see ref 30 and 305 for relations between $\langle \Delta E \rangle$ and $\langle \Delta E \rangle_d$):

$$\langle \Delta E \rangle_d / \text{cm}^{-1} = (200 \pm 20) + (0.005 \pm 0.002) \langle E \rangle / \text{cm}^{-1}$$

This work^{151,273} is particularly noteworthy also for quantitative master equation simulations including approximately both case C nonlinear pumping and collisional effects.

Very recently, Barfknecht and Brauman²⁷⁴ have used IR photochemistry to investigate collisional deactivation of ions using IR-visible resonance enhanced dissociation. By varying the time between CO_2 and dye laser pulses and measuring the CO_2 laser enhancement of the dissociation as a function of delay time, they have determined quenching rate constants and $\langle \Delta E \rangle$ for collisions of bromo-3-(trifluoromethyl)benzene cation with parent neutral, pentane, butane, propane, and helium.

Of course, there is a vast body of work on collisional energy transfer in highly excited molecules related to thermal unimolecular reactions and chemical activation systems. For details on these we refer to previous reviews.^{30,305,32,253} IR multiphoton excitation has been used comparatively little, so far, in this context, but it has the potential to contribute more substantially in the future.

5. Special Experimental Advances in IR-Laser Chemistry

The boundaries of our quantitative understanding of URIMIR have been determined in part by experimental limitations. Well-defined intensities have only recently been obtained. High-energy densities with well-defined fluence profiles are difficult to obtain due to optical material damage thresholds. Finally, information has generally only been provided at the discrete frequencies of the TEA CO_2 laser. In this chapter we mention some advances in studies of IR multiphoton absorption and URIMIR using picosecond pulses, shaped pulses, continuously tunable lasers, and bulk IR photolysis with high but still well-defined energy densities.

Kwok et al.²⁷⁶⁻²⁷⁹ have used pulses between 30–300 ps generated via optical free induction decay in CO_2 to study multiphoton absorption in SF_6 ^{276,278} and $\text{C}_2\text{F}_5\text{Cl}$ ²⁷⁹ at time scales short compared to those of collisions and unimolecular dissociation. From direct transmission

measurements on picosecond CO_2 laser absorption after vibrational-rotational preheating with a standard laser pulse, they have inferred a more than linear intensity dependence for multiphoton absorption in SF_6 .²⁷⁸ Recently, Mukherjee and Kwok²⁷⁹ have extended this method. $\text{C}_2\text{F}_5\text{Cl}$ was preheated at 982 cm^{-1} by a standard CO_2 laser pulse, then probed with picosecond pulses at $930\text{--}950 \text{ cm}^{-1}$, where there is no significant absorption in the ground-state molecule; thus relatively highly excited molecules were preferentially observed. In this case as well they observed an intensity- rather than fluence-determined absorption, which is consistent with the case C master equation treatment of URIMIR and complementary to the fluence dependence of product yield in case B.

Picosecond pulses have not yet to our knowledge been used in studies of other aspects of IR photochemistry, for example in the measurement of product yields. Here it might be possible to observe experimentally an interesting prediction of the statistical theory of URIMIR.¹⁰ Pulses in the 100-ps range have about 10^3 times higher intensity than conventional pulses of the same nominal fluence. At such intensities it could be possible to observe case D behavior, in which the higher intensity pulse at a given fluence produces a *lower* yield. A similar, smaller effect would be produced by case B falloff.¹⁰

Picosecond pulses should also be of interest in isotope separation. Excitation on a short time scale should enhance efficient pumping for dilute isotopic species at high gas pressures, at which competition between excitation and collisional energy transfer can affect yields and selectivity for standard pulses (see also ref 169g). It may be pointed out that pulses of about 1 ns could, in principle, be cheaply produced from an atmospheric CO_2 laser and would allow efficient IR photochemistry and isotope separation at about atmospheric pressure.

Recently, there have been further advances in CO_2 laser technology which have produced even shorter pulses. Corkum^{280,281} has used optical semiconductor switching of the output of a single-mode CO_2 laser, followed by amplification and pulse compression in a multiatmosphere CO_2 amplifier to produce 600-fs pulses with fluences of up to 1.5 J cm^{-2} within the resonator. This corresponds to an average intensity of over $10^{12} \text{ W cm}^{-2}$. Research is underway on methods of coupling such intense radiation out of the amplifier cavity without damage to optical components. Since 600 fs corresponds to a fairly small number of vibrational periods, one might observe interesting effects from the application of such pulses to URIMIR, including possibly true molecular ionization.

Temporal pulse shaping is an important technical development for URIMIR. The use of approximately square-wave temporal pulse forms has allowed the quantitative study of intensity effects separated from fluence effects. The application of pulse shaping to IR photochemistry was reported by Ashfold, Atkins, and Hancock²⁴¹ in 1981. Approximately constant-intensity slices of variable length were cut from the output of a single mode CO_2 laser by fast switching of a GaAs electrooptical crystal. After amplification these pulses were used to excite luminescence from OsO_4 . For a given fluence substantially more luminescence was observed for higher intensity excitation. Hancock et al.

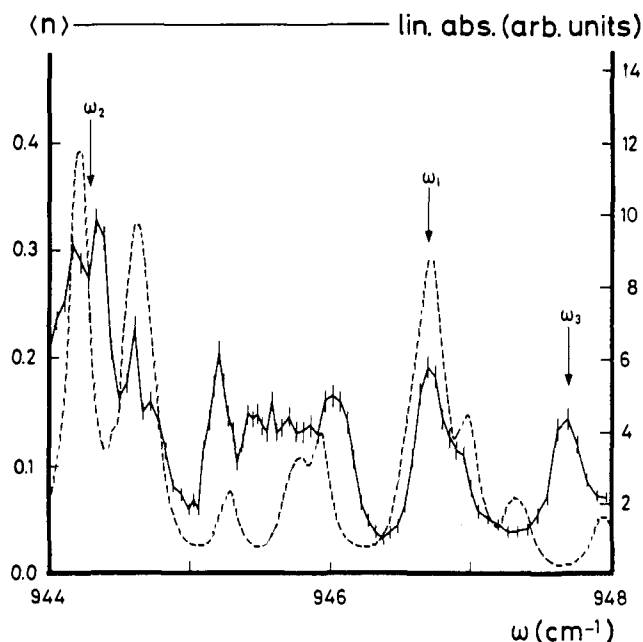

Figure 12. Spectral structures in the IR multiphoton absorption spectrum of SiH_4 . The dashed line is the linear absorption spectrum. Reproduced with permission from *Chem. Phys. Lett.* 1985, 122, 480. Copyright 1985 Elsevier.

have also used shaped pulses to investigate IR multiphoton absorption in SF_6 ,^{242,243} where they reported enhanced absorption at higher intensity. King and Stephenson²³⁰ have reported enhanced yield and enhanced vibrational excitation in CF_2 product at higher intensity for the IRMPD of CHClF_2 and CF_2CClF using the same approach. They have also studied product translational energy and internal-state distributions from the IR photolysis of CH_3ONO with 50 ns square-wave pulses,²²⁴ but have not explicitly studied intensity dependence by varying the pulse length. Further investigations with square-wave pulses in URIMIR are desirable, because quantitative measurements of intensity effects are crucial to a full understanding of IR photochemistry (see also the work of McAlpine and Evans²⁸²). It is now generally accepted from numerous *qualitative* experiments (e.g. ref 313, 277–280, 244, 254) that nonlinear and nontrivial intensity effects do exist in IR–multiphoton pumping. However, *quantitative* measurements with shaped pulses remain a major goal and are urgently needed. It should be noted that the nonlinear intensity dependences are not due to the direct or Goepfert–Mayer multiphoton excitation mechanisms (section 2.5.). Indeed, an attempt to pump metal carbonyls at half the absorption frequency was unsuccessful to initiate *any* IRMPD even at high intensity.^{293b}

Line tunable CO_2 lasers do not allow the observation of fine spectral structure and resonances in URIMIR. Multiatmosphere CO_2 lasers^{283,284} offer continuous tunability within individual P and R branches of laser transitions because of pressure broadening, and are now commercially available. Alimpiev et al.²⁸⁵ studied the multiphoton absorption spectrum of SF_6 at two fluences with a tuning step of 0.06 cm^{-1} using a multiatmosphere laser, and observed a rich spectral structure that had not been observed by line-tunable laser studies. Borsella et al.^{286–288} have used the same approach to probe

spectral structures in the multiphoton absorption of CF_3I , $\text{C}_2\text{F}_5\text{Cl}$, SiH_4 , and CF_3Br . These molecules have all exhibited detailed structure in the multiphoton absorption spectrum. An example of an optoacoustic absorption spectrum of SiH_4 is shown in Figure 12. To our knowledge, continuously tunable lasers have not yet been used to search for structures in multiphoton dissociation yield spectra, though this would be an interesting undertaking. It has been discussed, whether perhaps the structure arises through the properties of the laser light (bandwidth and coherence) rather than of the molecule, because in some experiments there are interesting correlations between the spectral structures and laser resonance lines.^{353,354} This seems, however, not to be the case for the results shown in Figure 12.

Another experimental advance, which is not a development in laser technology, is a new type of bulk photolysis sample cell which allows irradiation of samples at high-energy densities with well-defined fluence profiles and parallel irradiation geometries. Previously, the maximum available fluence for IR photolysis with controlled parallel irradiation was limited by the damage threshold for salt entrance windows (NaCl , KBr , KCl — NaCl being probably best), which is typically near 10 – 12 J cm^{-2} nominal fluence at Brewster's angle for approximately 1-J total energy in a standard multimode pulse with an approximately Gaussian beam profile. Focusing the beam within the reaction cell increases the maximum fluence but introduces additional uncertainties in data analysis. We have reported an alternative high-fluence photolysis cell which uses an inverse Galilean telescope to concentrate the beam.²⁸⁹ The incoming, nearly parallel beam is partially focused by a salt lens through a Brewster angle entrance window onto a convex Cu or Mo mirror, which makes the beam parallel. The concentrated beam is directed along the length of the cell to a flat mirror and reflected back along the same optical path and out of the cell. This optical arrangement allows high fluences between the two mirrors with a fluence at the entrance/exit window of only $\sim 10\text{ J cm}^{-2}$. The high fluence cell has been used to determine $k(st)$ for CCl_3F ²⁸⁹ and for several fluorinated butanes²¹² with nominal fluences of up to 22 J cm^{-2} . It is in principle possible to obtain still higher fluences with other ratios of lens and mirror focal lengths. The maximal possible fluence is limited by the damage threshold of the mirror material, which is much higher than that of window materials, and at higher pressures by the threshold for ionization near the surface of the first mirror, where the energy density is maximum. The high fluence cell has opened a new range of molecules to IR photochemistry and $k(st)$ determination, which do not react sufficiently at low fluences to allow quantitative analysis of data from conventional cells.

Another experimental advance relating to quantitative IR photochemistry results from time-resolved studies of reactant and product formation. Early experiments using UV absorption spectroscopy were performed by several groups.²⁹⁰ Duperrex and van den Bergh²⁹¹ have improved upon the Kleinermanns technique by performing real time observation during and after the pulse, which is of interest in relation to slow after pulse dissociation in CF_2HCl .

These techniques have inherent sensitivity problems when one tries to investigate small volumes with high

fluence of irradiation. A new technique which may help solve the sensitivity problem has been developed by Rayner and Hackett.²⁹² These authors have used visible-laser-induced multiphoton ionization of the iodine product atom in iodide IR photochemistry. They have thereby obtained high spatial resolution and high time resolution. The same research group has also used frequency doubled CO₂-laser radiation for IR-laser chemistry of cyclobutanone²⁹³ with pumping frequencies between 2180 cm⁻¹ and 1750 cm⁻¹. We should mention here as well the continuing developments of multifrequency irradiation with IR lasers.^{294,295} These have been proposed to be particularly relevant for laser isotope separation.

Another laser advance is the development of high-power laser radiation in the 16- μ m region using *p*-H₂ Raman shifting. The use of stimulated Stokes Raman shifting of CO₂ laser output to produce a 16- μ m laser has been reported by Rabinowitz et al.^{296,298} and more recently investigated by Bernardini et al.²⁹⁷ Energies of up to 1.6 J/pulse and energy conversion efficiencies of up to 85% have been reported. Due to pulse compression²⁹⁸ the intensity of the Raman shifted pulse can actually be higher than the initial CO₂ laser intensity.²⁹⁷ Recently,²⁹⁹ a Raman-shifted laser has been used to study the IR-multiphoton-induced decomposition of Fe(CO)₅ under irradiation at 616.2 cm⁻¹.

Finally, a subject which is indirectly related to IR-laser chemistry is the measurement of IR-multiphoton absorption in cooled supersonic jets.³⁰⁰ Such data are still not very abundant but the development has to be followed because of its importance in the comparison with full quantum theoretical calculations.¹⁴ Energy transfer in supersonic beams has also been studied with CW-CO₂-laser pumping.³⁰¹

6. Concluding Remarks and Outlook

The present review reflects the enormous progress that has been made in the field of IR-laser photochemistry since the days of the first extensive discussions of the subject, not even a decade ago. And this is true, even though we have on purpose omitted a large body of theoretical work on radiative processes closely related to IR-multiphoton excitation, but dealing mainly with questions concerning idealized model problems and specialized techniques of interest to the mathematical physicist. Rather than apologizing for this omission, and for many inadvertent omissions of other relevant work, we wish to stress here the emphasis of the present article: The combination of theory and experiment in *one* article and the stress on *quantitative* methods and results. However incomplete and imperfect the approach to our goal may be, it certainly distinguishes this synthesis from most previous reviews, which were either mostly experimental or theoretical. There was good reason for the present attempt of a synthesis of quantitative experimental and theoretical aspects. The future of the field of IR-laser chemistry in terms of laboratory experiments and specialized kinetics applications is not subject to any doubt. However, the possibility of large-scale technological applications is being questioned,¹⁷⁵ and there has certainly been a period of disenchantment in the area of isotope separation, where there were great hopes initially. We believe that some

of the failures in the development of IR-laser chemistry for large scale technology are due to a too alchemical early approach with inadequate theoretical understanding and methodology. Rather than providing evidence for this point of view, we shall conclude with a historical parable for the importance of the interaction of fundamental theory and experiment in the evolution of large scale applications of new physical-chemical methods.³⁴⁵ Our account will illustrate a less widely known (in fact practically overlooked in popular accounts) detail in the otherwise well-known and often repeated history of ammonia synthesis.^{346,347}

Toward the end of the 19th century nitrogen in the form of nitrates or ammonia was used extensively as the basis for fertilizers in agriculture and for explosives in more or less peaceful circumstances. However, the natural nitrate resources were known to be very limited and the "artificial nitrogen" was expensive. Various scenarios were worked out around 1900, which predicted the end of the nitrogen resources and as a result major famines by 1930. Already between 1879 and 1883 a war had been fought between Chile, Peru, and Bolivia over the control of the nitrate deposits in the Atacama desert. Whereas this procedure seems to have been to the politicians the natural method to obtain control over essential resources, some physical chemists turned their interest towards practical methods to convert atmospheric nitrogen. By 1904 the direct synthesis was still unknown:

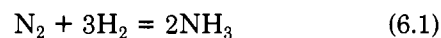

Fritz Haber then started investigations of this equilibrium at high temperatures and used van't Hoff's method to extrapolate the equilibrium constant.^{348,349,350} Haber concluded that the direct synthesis was impractical as a basis for large scale technology and gave up by 1905. One notes that at this time there was no method available that would have permitted him an independent theoretical check of his measurements. In 1906 Nernst published the third law of thermodynamics, a major *theoretical* advance, which allowed him to compute absolute equilibrium constants without direct measurement.³⁵¹ Being very different from what would nowadays be considered a specialized theoretical chemist,³⁵² he immediately applied his theory to recent equilibrium measurements of interest and found disagreement with Haber's results for eq 6.1. This resulted in an open controversy at the traditional spring meeting of the Bunsengesellschaft für Physikalische Chemie in Hamburg, 1907. Theory was right, in principle, and mainly due to the impetus and confidence gained by the new theoretical background Haber started his work again, although the theoretical predictions were *less* favorable for ammonia production under Haber's initial experimental conditions. However, now improvements could be planned and realized securely. By 1909 he successfully produced fair amounts on a laboratory scale (about 1 mmol s⁻¹). For reasons that have been well documented in textbooks of general history, the direct synthesis of ammonia produced in Germany about 10⁸ kg NH₃ per year by 1918 (i.e., about at a rate of 200 mol s⁻¹). It may be noted that ammonia synthesis was by no means the only source of "artificial nitrogen", about similar amounts due to all other methods together being produced in 1918. Ammonia synthesis evolved as a

large scale technology "just because it was much more efficient."

We leave it to the reader to establish analogies to the present day situation of the evolution of applications of IR-laser photochemistry. We hope that this time the military aspects of the analogy can be avoided (the first world war was fought largely with ammonia synthesis). More useful and more beneficial applications are just around the corner even with laser isotope separation—for instance in the use of large quantities of stable isotopes for medical investigations. Simple estimates show that in this area IR-photochemical methods should have a decisive advantage over classical methods. And, of course, there are many applications beyond isotope separation. We believe in a substantial future of IR-laser chemistry also in terms of technical applications and hope that our article stimulates further research in this direction.

Acknowledgments. Our research is supported financially by the Schweizerischer Nationalfonds and the Schweizerischer Schulrat. We are indebted to many colleagues for conversations and correspondence and for making reprints and preprints of their work available for this article.

References

- (1) Bordé, M. C.; Henry, A.; Henry, M. L. *C. R. Séances Acad. Sci., Ser. B* **1966**, 263B, 619.
- (2) Isenor, N. R.; Richardson, M. C. *Appl. Phys. Lett.* **1971**, 18, 225.
- (3) Isenor, N. R.; Merchant, V.; Hallsworth, R. S.; Richardson, M. C. *Can. J. Phys.* **1973**, 51, 121.
- (4) Ambartzumian, R. V.; Gorokhov, Y. A.; Letokhov, V. S.; Makarov, G. N. *JETP Lett.* **1975**, 21, 171.
- (5) Lyman, J. L.; Jensen, R. J.; Rink, J.; Robinson, G. P.; Rockwood, D. S. *Appl. Phys. Lett.* **1975**, 27, 87.
- (6) Coggiola, M. J.; Schulz, P. A.; Lee, Y. T.; Shen, Y. R. *Phys. Rev. Lett.* **1977**, 38, 17.
- (7) Grant, E. R.; Schulz, P. A.; Sudbo, Aa. S.; Shen, Y. R.; Lee, Y. T. *Phys. Rev. Lett.* **1978**, 40, 115.
- (8) Diebold, G. J.; Engelke, F.; Lubman, D. M.; Whitehead, J. C.; Zare, R. N. *J. Chem. Phys.* **1977**, 67, 5407.
- (9) Brunner, F.; Cotter, T. P.; Kompa, K. L.; Proch, D. *J. Chem. Phys.* **1977**, 67, 1547.
- (10) Quack, M. *J. Chem. Phys.* **1978**, 69, 1282.
- (11) Quack, M. *Ber. Bunsenges. Phys. Chem.* **1979**, 83, 757.
- (12) Quack, M. *Ber. Bunsenges. Phys. Chem.* **1979**, 83, 1287.
- (13) Quack, M. *Ber. Bunsenges. Phys. Chem.* **1981**, 85, 318.
- (14) Quack, M.; Sutcliffe, E. *Chem. Phys. Lett.* **1983**, 99, 167.
- (15) Letokhov, V. S.; Moore, B. S. *Sov. J. Quantum Electron (Engl. Transl.)* **1977**, 66, 4317.
- (16) Ambartzumian, R. V.; Letokhov, V. S. *Acc. Chem. Res.* **1977**, 10, 61.
- (17) Grunwald, E.; Dever, D. F.; Keehn, P. M. *Megawatt Infrared Laser Chemistry*; Wiley: New York, 1978.
- (18) Bloembergen, N.; Yablonovitch, E. *Phys. Today* **1978**, 33, 23.
- (19) Harrison, R. G.; Butcher, S. R. *Contemp. Phys.* **1980**, 21, 19.
- (20) Lee, Y. T.; Shen, Y. R. *Phys. Today* **1980**, 33, 52.
- (21) Schulz, P. A.; Sudbo, Aa. S.; Krajnovich, D. J.; Kwok, H. S.; Shen, Y. R.; Lee, Y. T. *Annu. Rev. Phys. Chem.* **1979**, 30, 379.
- (22) Golden, D. M.; Rossi, M. J.; Baldwin, A. C.; Barker, J. R. *Acc. Chem. Res.* **1981**, 14, 56.
- (23) Reisler, H.; Wittig, C. *Adv. Chem. Phys.* **1985**, 60, 1.
- (24) Letokhov, V. S. *Nonlinear Laser Chemistry. Multiple Photon Excitation*; Springer Verlag: Berlin, 1983.
- (25) Bagratashvili, V. N.; Letokhov, V. S.; Makarov, A. A.; Ryabov, E. A. *Multiple Photon Infrared Laser Photophysics and Photochemistry*; Harwood Academic: New York, 1985; *Laser Chem.* **1983**, 1, 211, 4, 101, 171; **1984**, 4, 311, 5, 53.
- (26) Ashfold, M. N. R.; Hancock, G. *Gas Kinetics and Energy Transfer*; The Chemical Society: London, 1981, Vol. 4, p 73.
- (27) Danen, W. C.; Jang, J. C. In *Laser Induced Chemical Processes*; Steinfeld, J. I., Ed.; Plenum: New York, 1981.
- (28) King, D. S. *Adv. Chem. Phys.* **1982**, 50, 105.
- (29) Quack, M. *Chimia* **1981**, 35, 463.
- (30) Quack, M.; Troe, J. *Int. Rev. Phys. Chem.* **1981**, 1, 97.
- (31) Fuß, W.; Kompa, K. *Prog. Quantum Electron* **1981**, 7, 117.
- (32) Bailey, R. T.; Cruickshank, F. R. *Annu. Rep. Prog. Chem.* **1978**, 75A, 49.
- (33) (a) Francisco, J. R.; Steinfeld, J. I. In *Advances in Multiphoton Processes and Spectroscopy*; Lin, S. H. Ed.; Vol. 3, in press. (b) Steinfeld, J. I. In *Laser Induced Chemical Processes*; Steinfeld, J. I. Ed.; Plenum: New York, 1981.
- (34) Oref, I.; Rabinovitch, B. S. *Acc. Chem. Res.* **1979**, 12, 166.
- (35) Ashfold, M. N. R. *Photochemistry*; Specialist Periodical Report: The Royal Society of Chemistry: Burlington House, London, 1983; Vol. 14, p 62.
- (36) Moylan, C. R.; Brauman, J. I. *Int. J. Chem. Kinet.* **1986**, 18, 379.
- (37) Hack, W. *Int. Rev. Phys. Chem.* **1985**, 4, 165.
- (38) Kimel, S.; Speiser, S. *Chem. Rev.* **1977**, 77, 437.
- (39) Ben-Shaul, A.; Haas, Y.; Kompa, K. L.; Levine, R. D. *Lasers and Chemical Change*. Springer-Verlag: Berlin, 1981.
- (40) Kneba, M.; Wolfrum, J. *Annu. Rev. Phys. Chem.* **1980**, 31, 47.
- (41) Wolfrum, J. In *Reactions of Transient Species*; Fontijn, A., Clyne, M. A. A., Eds. Academic: New York, 1983.
- (42) Zare, R. N. *Scientific American* **1977**, 236, 86.
- (43) Letokhov, V. S. *Nature* **1979**, 277, 605.
- (44) Becker, F. S.; Kompa, K. L. *Europhys. News* **1981**, 12, 2.
- (45) Jensen, R. J.; Judd, O'Dean P.; Sullivan, J. A. *Los Alamos Sci.* **1982**, 3, 2. Lyman, J. L.; Galbraith, H. W.; Ackerhalt, J. R. *Los Alamos Sci.* **1982**, 3, 66.
- (46) Lyman, J. L. In *Applications of Lasers and Spectroscopy*; Radziemski, L.; Solarz, R. W.; Paisner, J. A. Eds.; Dekker: New York, 1985.
- (47) McAlpine, R. D.; Evans, D. K. *Adv. Chem. Phys.* **1985**, 60, 31.
- (48) van den Bergh, H. *Laser Optoelektron.* **1985**, 17, 263.
- (49) Heidberg, J.; Stein, H.; Riehl, E.; Nestmann, A. *Z. Phys. Chem. (Munich)* **1980**, 121, 145.
- (50) Heidberg, J.; Stein, H.; Riehl, E. *Phys. Rev. Lett.* **1982**, 49, 666.
- (51) Heidberg, J.; Stein, H.; Riehl, E. *Surf. Sci.* **1983**, 126, 183.
- (52) Heidberg, J.; Stein, H.; Riehl, E.; Szilagyi, Z.; Weiss, H. *Surf. Sci.* **1985**, 158, 553.
- (53) Heidberg, J. *Math. Res. Soc. Symp. Proc.* **1984**, 29, 333.
- (54) Heidberg, J.; Stein, H.; Szilagyi, Z.; Hoge, D.; Weiss, H. In *Dynamics on Surfaces*; Pullman, B.; Jortner, J.; Nitzan, A., Gerber, B., Eds.; Reichel: Dordrecht, 1984, p 329.
- (55) Chuang, T. J.; Seki, H. *Phys. Rev. Lett.* **1982**, 49, 382.
- (56) Chuang, T. J. *Surf. Sci. Rep.* **1983**, 3, 1.
- (57) George, T. F.; Lin, J.; Beri, A.; Murphy, W. C. *Prog. Surf. Sci.* **1985**, 16, 139.
- (58) (a) Cantrell, C. D.; Freund, S. M.; Lyman, J. L. In *Laser Handbook*; Stich, E. L., Ed.; North Holland: Amsterdam, 1979, Vol. IIIb. (b) Lyman, J. L.; Quigley, G. D.; Judd, O. P. In *Multiphoton Excitation and Dissociation of Polyatomic Molecules*; Cantrell, C. D. Ed.; Springer-Verlag: Berlin, 1980.
- (59) Cantrell, C. D.; Ketokhov, V. S.; Makarov, A. A. In *Topics in Current Physics, Coherent Nonlinear Optics-Recent Advances*; Field, M. S., Letokhov, V. S., Eds.; Springer-Verlag: Berlin, 1980.
- (60) Quack, M. *Adv. Chem. Phys.* **1982**, 50, 395.
- (61) Quack, M. In *Recent Advances in Molecular Reaction Dynamics*; Vetter, R., Vigué, J. Eds.; Editions du CNRS: Paris, 1986; p 391.
- (62) Galbraith, H. W.; Ackerhalt, J. R. In *Laser-Induced Chemical Processes*; Steinfeld, J. I., Ed.; Plenum: New York, 1981.
- (63) Chu, Shi-I. *Adv. At. Mol. Phys.* **1985**, 21, 197.
- (64) Walker, R. B.; Preston, R. K. *J. Chem. Phys.* **1977**, 67, 2017.
- (65) Noid, D. W.; Koszykowski, M. L.; Marcus, R. A. *J. Chem. Phys. Lett.* **1977**, 51, 5401.
- (66) Bunker, D. L. *Methods Comput. Phys.* **1971**, 10, 287.
- (67) Lamb, W. E., Jr. In *Laser Spectroscopy III*; Hall, J. L., Carlsten, J. L., Eds.; Springer Series in Optical Sciences 7; Springer-Verlag: Berlin, 1979; p 116.
- (68) Hänsel, K. D. In *Laser Induced Processes in Molecules*; Kompa, K. L., Smith, S. D., Eds.; Springer-Verlag: Berlin, 1979; p 145.
- (69) Hänsel, K. D. *Chem. Phys. Lett.* **1978**, 57, 619.
- (70) Ramaswamy, R.; Siders, P.; Marcus, R. A. *J. Chem. Phys.* **1981**, 74, 4418.
- (71) Davis, M. J.; Wyatt, R. E.; Leforestier, C. In *Intramolecular Dynamics*; Jortner, J., Pullman, B., Eds.; Reidel: Dordrecht, 1982; p 403.
- (72) Poppe, D. *Chem. Phys.* **1979**, 45, 371.
- (73) Poppe, D. *Chem. Phys. Lett.* **1980**, 75, 264.
- (74) Poppe, D. *J. Chem. Phys.* **1981**, 74, 5326.
- (75) Noid, D. W.; Koszykowski, M. L.; Marcus, R. A. *J. Chem. Phys.* **1977**, 67, 404.
- (76) Miller, W. H. *Adv. Chem. Phys.* **1974**, 25, 69.
- (77) Miller, W. H. *Adv. Chem. Phys.* **1975**, 30, 77.
- (78) Miller, W. H. *J. Chem. Phys.* **1978**, 69, 2188.
- (79) Mukamel, S.; Jortner, J. *J. Chem. Phys.* **1976**, 65, 5204.
- (80) Haroche, S. *Ann. Phys. (Paris)* **1971**, 6, 189.
- (81) Rabi, I. I. *Phys. Rev.* **1937**, 51, 652.
- (82) Shirley, J. H. *Phys. Rev. B: Condens. Matter* **1965**, 138, 979.
- (83) Leasure, S.; Wyatt, R. E. *J. Chem. Phys.* **1981**, 74, 6197.

- (84) Leforestier, C.; Wyatt, R. E. *Chem. Phys.* **1985**, *98*, 123.
 (85) Chu, S. I.; Ho, T. S. *Isr. J. Chem.* **1984**, *24*, 237.
 (86) Milfeld, K. F.; Wyatt, R. E. *Phys. Rev. A* **1983**, *27*, 72.
 (87) Leforestier, C.; Wyatt, R. E. *J. Chem. Phys.* **1985**, *82*, 752.
 (88) Nauts, A.; Wyatt, R. E. *Phys. Rev. Lett.* **1983**, *51*, 2238.
 (89) Wyatt, R. E.; Hose, G.; Taylor, H. S. *Phys. Rev. A* **1983**, *28*, 815.
 (90) Nauts, A.; Wyatt, R. E. *Phys. Rev. A* **1984**, *30*, 872.
 (91) Ho, T. S.; Chu, S. I. *J. Chem. Phys.* **1983**, *79*, 4708.
 (92) Ho, T. S.; Chu, S. I. *Phys. Rev. A* **1985**, *32*, 377.
 (93) Ho, T. S.; Chu, S. I. *Chem. Phys. Lett.* **1985**, *122*, 327.
 (94) Stone, J.; Thiele, E.; Goodman, M. F. *J. Chem. Phys.* **1981**, *75*, 1712.
 (95) Kay, K. G. *J. Chem. Phys.* **1981**, *75*, 1690.
 (96) Grant, E. R.; Schulz, P. A.; Sudbo, A. S.; Shen, Y. R.; Lee, Y. T. *Phys. Rev. Lett.* **1978**, *40*, 115.
 (97) Lyman, J. L. *J. Chem. Phys.* **1977**, *67*, 1868.
 (98) Fuss, W. *Chem. Phys.* **1979**, *36*, 135.
 (99) Messiah, A. *Mécanique Quantique* Dunod: Paris, 1966.
 (100) Hodgkinson, D. P.; Briggs, J. *Chem. Phys. Lett.* **1976**, *43*, 451.
 (101) Stone, J.; Goodman, M. F. *J. Chem. Phys.* **1979**, *71*, 408.
 (102) Chou, J.-S. J.; Grant, E. *J. Chem. Phys.* **1981**, *74*, 384.
 (103) Schek, I.; Jortner, J.; Sage, M. L. *Chem. Phys.* **1981**, *58*, 11.
 (104) Schek, I.; Sage, M. L.; Jortner, J. *Chem. Phys. Lett.* **1979**, *63*, 230.
 (105) Quack, M. *Chem. Phys. Lett.* **1979**, *65*, 140.
 (106) von Puttkamer, K.; Dübal, H. R.; Quack, M. *Faraday Discuss. Chem. Soc.* **1983**, *75*, 197, 263.
 (107) Dübal, H.-R.; Quack, M. *J. Chem. Phys.* **1984**, *81*, 3779.
 (108) Dübal, H.-R.; Quack, M. *Mol. Phys.* **1984**, *53*, 257.
 (109) Baggott, J. E.; Chuang, M.-C.; Zare, R. N.; Dübal, H.-R.; Quack, M. *J. Chem. Phys.* **1985**, *82*, 1186.
 (110) Dübal, H.-R.; Quack, M. *Chem. Phys. Lett.* **1981**, *80*, 439.
 (111) Quack, M. *Faraday Discuss. Chem. Soc.* **1981**, *71*, 359.
 (112) Hodgkinson, D. P.; Taylor, A. J. *Mol. Phys.* **1984**, *52*, 1017.
 (113) Whaley, K. B.; Light, J. C. *Phys. Rev. A* **1984**, *29*, 1188.
 (114) Clary, D. C. *J. Phys. Chem.* **1983**, *87*, 735.
 (115) (a) Quack, M.; Sutcliffe, E. *J. Chem. Phys.* **1985**, *83*, 3805. (b) Quack, M.; Sutcliffe, E. URIMIR, a set of programs, Quantum Chemistry Program Exchange No. 515, *QCPE Bull.* **1986**, *6*, 98.
 (116) Borsella, E.; Fantoni, R.; Giardini-Guidoni, A.; Masci, D.; Palucci, A.; Reuss, J. *Chem. Phys. Lett.* **1982**, *93*, 523.
 (117) Quack, M.; Sutcliffe, E. *Chem. Phys. Lett.* **1985**, *121*, 315.
 (118) Schek, I.; Jortner, J. *J. Chem. Phys.* **1979**, *70*, 3016.
 (119) Schek, I.; Jortner, J.; Sage, M. L. *Chem. Phys.* **1981**, *59*, 11.
 (120) Carmeli, B.; Tulman, R.; Nitzan, A.; Kalos, M. H. *Chem. Phys.* **1982**, *72*, 363.
 (121) Carmeli, B.; Nitzan, A. *J. Chem. Phys.* **1980**, *72*, 2070.
 (122) Carmeli, B.; Schek, I.; Nitzan, A.; Jortner, J. *J. Chem. Phys.* **1980**, *72*, 1928.
 (123) Goepfert-Mayer, M. *Ann. Phys.* **1931**, *9*, 273.
 (124) Einstein, A. *Verh. Dtsch. Phys. Ges.* **1916**, *18*, 318. Einstein, A. *Phys. Z.* **1917**, *18*, 121.
 (125) Einstein, A. *Mitt. Phys. Ges. (Zürich)* **1916**, *18*, 47.
 (126) Quack, M. *Bull. ETH-Zürich* **1984**, *189*, 19.
 (127) Quack, M.; Troe, J. *Ber. Bunsenges. Phys. Chem.* **1974**, *78*, 240.
 (128) Quack, M.; Troe, J. *Ber. Bunsenges. Phys. Chem.* **1975**, *79*, 170.
 (129) Quack, M.; Troe, J. *Theor. Chem. (N.Y.)* **1981**, *6B*, 199.
 (130) Quack, M. *J. Phys. Chem.* **1979**, *83*, 150.
 (131) Quack, M. *Nuovo Cimento* **1981**, *63B*, 358.
 (132) Quack, M. *J. Chem. Phys.* **1985**, *82*, 3277.
 (133) Marcus, R. A. *J. Chem. Phys.* **1952**, *20*, 359.
 (134) Marcus, R. A.; Rice, O. K. *J. Phys. Colloid Chem.* **1951**, *55*, 894.
 (135) Marcus, R. A. *J. Chem. Phys.* **1965**, *43*, 2658.
 (136) Giddings, J. C.; Eyring, H. *J. Chem. Phys.* **1954**, *22*, 538.
 (137) Rosenstock, H. M.; Wallenstein, M. B.; Wahrhaftig, A. L.; Eyring, H. *Proc. Nat. Acad. Sci. U.S.A.* **1952**, *38*, 667.
 (138) Quack, M. *Mol. Phys.* **1977**, *34*, 477.
 (139) Quack, M. *Stud. Phys. Theor. Chem.* **1983**, *23*, 355.
 (140) Lederman, S. M.; Marcus, R. A. *J. Chem. Phys.* **1984**, *81*, 5601.
 (141) Sinha, A.; Kinsey, J. L. *J. Chem. Phys.* **1984**, *80*, 2029.
 (142) Dietrich, P.; Quack, M.; Seyfang, G. *Faraday Discuss. Chem. Soc.*, in press.
 (143) Quack, M. *Chem. Phys.* **1980**, *51*, 353.
 (144) Quack, M. In *Intramolecular Dynamics*; Jortner, J., Pullman, B., Eds.; Reidel: Dordrecht, 1982; p 371.
 (145) Worry, G.; Marcus, R. A. *J. Chem. Phys.* **1977**, *67*, 1636.
 (146) Quack, M. *J. Chem. Phys.* **1979**, *70*, 1069.
 (147) Barker, J. R. *J. Chem. Phys.* **1980**, *72*, 3686.
 (148) Baldwin, A. C.; Barker, J. R. *J. Chem. Phys.* **1981**, *74*, 3813.
 (149) Lawrence, W. D.; Knight, A. E. W.; Gilbert, R. G.; King, K. D. *Chem. Phys.* **1981**, *56*, 343.
 (150) Eberhardt, J. E.; Knott, R. B.; Pryor, A. W.; Gilbert, R. G. *Chem. Phys.* **1982**, *69*, 45.
 (151) Zellweger, J.-M.; Brown, T. C.; Barker, J. R. *J. Chem. Phys.* **1985**, *83*, 6251, 6261.
 (152) Troe, J. *J. Chem. Phys.* **1980**, *73*, 3205.
 (153) Ambartzumian, R. V.; Letokhov, V. S.; Ryabov, E. A.; Chekalin, N. V. *JETP Lett.* **1974**, *20*, 273.
 (154) Lederer, M. *Encyclopedia of Chemical Technology*; Wiley: New York, 1981.
 (155) Seyfang, G. Dissertation, Universität Göttingen, 1982.
 (156) Gozel, P.; van den Bergh, H.; Lupo, D.; Quack, M.; Seyfang, G., manuscript in preparation.
 (157) Hason, A.; Gozel, P.; van den Bergh, H. *Helv. Phys. Acta* **1982**, *55*, 187. Hason, A.; Gozel, P.; van den Bergh, H. *Appl. Phys.* **1982**, *B29*, 188.
 (158) Lupo, D.; Quack, M.; Vogelsanger, B. *Helv. Chim. Acta*, in press.
 (159) Ambartzumian, R. V.; Furzikov, N. P.; Letokhov, V. S.; Dyad'kin, A. P.; Grasyuk, A. Z.; Vasilyev, B. I. *Appl. Phys.* **1978**, *15*, 27.
 (160) Evans, D. K.; McAlpine, D.; McClusky, F. K. *Chem. Phys.* **1978**, *32*, 81.
 (161) Evans, D. K.; McAlpine, R. D.; McClusky, F. K. *Chem. Phys. Lett.* **1979**, *65*, 226.
 (162) Evans, D. K.; McAlpine, R. D.; Adams, H. M. *J. Chem. Phys.* **1982**, *77*, 3551.
 (163) Parthasarathy, V.; Sarkar, S. K.; Rao, K. V. S. Rama; Mittal, J. P. *Appl. Phys. B* **1986**, *B39*, 187.
 (164) Linyang, Zhang; Yunwu, Zhang; Xiangxiao, Ma; Peng, Yuan; Yan, Xu; Mengxiong, Gong; Fuß, W. *Appl. Phys. B* **1986**, *B39*, 117.
 (165) Miller, S. S.; DeFord, D. D.; Marks, T. J.; Weitz, E. *J. Am. Chem. Soc.* **1979**, *101*, 1036. Cuellar, E. A.; Miller, S. S.; Marks, T. J.; Weitz, E. *J. Am. Chem. Soc.* **1983**, *105*, 4580.
 (166) Horsley, J. A.; Cox, D. M.; Hall, R. B.; Kaldor, A.; Maas, E. T., Jr.; Priestley, E. B.; Kramer, G. M. *J. Chem. Phys.* **1980**, *73*, 3660.
 (167) Rabinowitz, P.; Kaldor, A.; Gnauck, A.; Woodin, R. L.; Gethrer, J. S. *Opt. Lett.* **1982**, *7*, 212. Rabinowitz, P.; Kaldor, A.; Gnauck, A. *Appl. Phys. B* **1982**, *B28*, 187.
 (168) Cauchetier, M.; Croix, O.; Luce, M.; Tistchenko, S. *Ber. Bunsenges. Phys. Chem.* **1985**, *89*, 290.
 (169) (a) Outhouse, A.; Lawrence, P.; Gauthier, M.; Hackett, P. A. *Appl. Phys. B* **1985**, *B36*, 63. (b) Drouin, M.; Gauthier, M.; Pilon, R.; Hackett, P. A.; Willis, C. *Chem. Phys. Lett.* **1978**, *60*, 16. (c) Hackett, P.; Gauthier, M.; Willis, C.; Drouin, M. *IEEE J. Quant. Electron.* **1980**, *QE-16*, 143. (d) Hackett, P. A.; Willis, C.; Gauthier, M. *J. Chem. Phys.* **1979**, *71*, 2682. (e) Hackett, P. A.; Willis, C.; Nip, W. S. *J. Am. Chem. Soc.* **1983**, *103*, 682. (f) Hackett, P. A.; Weinberg, E.; Gauthier, M.; Willis, C. *Chem. Phys. Lett.* **1981**, *82*, 89. (g) Gauthier, M.; Nip, W. S.; Hackett, P. A.; Willis, C. *Chem. Phys. Lett.* **1980**, *69*, 372.
 (170) Chou, J.-S. J.; Grant, E. *J. Chem. Phys.* **1981**, *74*, 5679.
 (171) Baranov, V. Yu.; Velikhov, E. P.; Kazakov, S. A.; Kolomiiskii, Yu. R.; Letokhov, V. S.; Pis'mennyi, V. D.; Ryabov, E. A.; Starodubtsev, A. I. *Sov. J. Quantum Electron. (Engl. Transl.)* **1979**, *9*, 486.
 (172) Philippoz, J.-M.; Calpini, B.; Monot, R.; van den Bergh, H. *Ber. Bunsenges. Phys. Chem.* **1985**, *89*, 291.
 (173) Makide, Y.; Hagiwara, S.; Tominaga, T.; Takeuchi, K.; Nakane, R. *Chem. Phys. Lett.* **1981**, *82*, 18.
 (174) de Mévergnies, M. Nève; Verhoeven, F.; del Marmol, P.; Koch, G. *J. Chem. Phys.* **1982**, *77*, 4786.
 (175) Cantrell, C. D. closing remarks at the Topical Meeting on Multiphoton Processes, Trieste-Miramare, Italy, 1985.
 (176) Ambartzumian, R. V.; Chekalin, N. V.; Letokhov, V. S.; Ryabov, E. A. *Chem. Phys. Lett.* **1975**, *36*, 301.
 (177) Ambartzumian, R. V.; Chekalin, N. V.; Doljikov, V. S.; Letokhov, V. S.; Ryabov, E. A. *Chem. Phys. Lett.* **1974**, *25*, 515.
 (178) Yahav, G.; Haas, Y. *Chem. Phys.* **1978**, *35*, 41. Haas, Y.; Ruhmann, S.; Greenblatt, O. D.; Anner, O. *J. Am. Chem. Soc.* **1985**, *107*, 5068.
 (179) Sausa, R. C.; Ronn, A. M. *Chem. Phys.* **1985**, *96*, 183.
 (180) Duignan, M. T.; Grunwald, E.; Speiser, S. *J. Phys. Chem.* **1983**, *87*, 4387.
 (181) Simpson, T. B.; Bloembergen, N. *Chem. Phys. Lett.* **1983**, *100*, 325.
 (182) Kompa, K. L.; Lamprecht, H.; Schröder, H.; Puretzky, A. A.; Tyakht, V. V. *J. Chem. Phys.* **1986**, *84*, 2020.
 (183) Borisevich, N. A.; Zalesskaya, G. A. *Spectrosc. Lett.* **1986**, *19*, 113.
 (184) Woodin, R. L.; Bomse, D. S.; Beauchamp, J. L. *J. Am. Chem. Soc.* **1978**, *100*, 3248.
 (185) Rosenfeld, R. N.; Jasinski, J. M.; Brauman, J. I. *J. Am. Chem. Soc.* **1982**, *104*, 658.
 (186) Bomse, D. S.; Beauchamp, J. L. *J. Am. Chem. Soc.* **1981**, *103*, 3292.
 (187) Wright, C. A.; Beauchamp, J. L. *J. Am. Chem. Soc.* **1981**, *103*, 6499.
 (188) Jasinski, J. M.; Brauman, J. I. *J. Chem. Phys.* **1980**, *73*, 6191.
 (189) Meyer, F. K.; Jasinski, J. M.; Rosenfeld, R. N.; Brauman, J.

- I. *J. Am. Chem. Soc.* **1982**, *104*, 663.
- (190) Thomas, W.; Foster, R. F.; Brauman, J. I. *Isr. J. Chem.* **1984**, *24*, 223.
- (191) Hughes, R. J.; March, R. E.; Young, A. B. *Can. J. Chem.* **1983**, *61*, 824, 834.
- (192) Young, A. B.; March, R. E.; Hughes, R. J. *Can. J. Chem.* **1985**, *63*, 2332.
- (193) Rossi, M. J.; Barker, J. R.; Golden, D. M. *J. Chem. Phys.* **1979**, *71*, 3722.
- (194) Selamoglu, N.; Rossi, M. J.; Golden, D. M. *Chem. Phys. Lett.* **1986**, *124*, 68.
- (195) Martinez, R. I.; Huie, R. E.; Herron, J. T.; Braun, W. J. *Phys. Chem.* **1980**, *84*, 2344.
- (196) Slagle, I. R.; Yamada, F.; Gutman, D. *J. Am. Chem. Soc.* **1980**, *103*, 149.
- (197) Yamada, F.; Slagle, I. R.; Gutman, D. *Chem. Phys. Lett.* **1981**, *83*, 409.
- (198) Slagle, I. R.; Gutman, D. *J. Am. Chem. Soc.* **1982**, *104*, 4741.
- (199) Hancock, G.; Ketley, G. W.; MacRobert, A. J. *J. Phys. Chem.* **1984**, *88*, 2104. Cookson, J. L.; Hancock, G.; McKendrick, K. G. *Ber. Bunsenges. Phys. Chem.* **1985**, *89*, 335.
- (200) Lesiecki, M. L.; Hicks, K. W.; Orenstein, A.; Guillory, W. A. *Chem. Phys. Lett.* **1980**, *71*, 72.
- (201) Thomas, J. W.; Steinfeld, J. I. *Chem. Phys. Lett.* **1986**, *124*, 35.
- (202) Rayner, D. M.; Steer, R. P.; Hackett, P. A.; Wilson, C. L.; John, P. *Chem. Phys. Lett.* **1986**, *123*, 449.
- (203) Stafast, H.; Pfister, R.; Huber, J. R. *J. Phys. Chem.* **1985**, *89*, 5074.
- (204) Dever, D. V.; Grunwald, E. *J. Am. Chem. Soc.* **1976**, *98*, 5055.
- (205) Butler, J. N.; Kistiakowski, G. B. *J. Am. Chem. Soc.* **1960**, *82*, 759.
- (206) von E. Doering, W.; Gilbert, J. C.; Leermaker, P. A. *Tetrahedron* **1968**, *29*, 6863.
- (207) Rynbrandt, J. D.; Rabinovitch, B. S. *J. Phys. Chem.* **1971**, *75*, 2164.
- (208) von E. Doering, W.; *ETH-Kolloquium 1983* and preprint 1985.
- (209) Quack, M.; Thöne, H. J. *Ber. Bunsenges. Phys. Chem.* **1983**, *87*, 582.
- (210) Manz, J.; Jakubetz, W. *Chem. Phys. Lett.* **1986**, *126*, 48; *Mol. Phys.*, in press.
- (211) Tannor, D. J.; Rice, S. A. *J. Chem. Phys.* **1985**, *83*, 5013.
- (212) Quack, M.; Thöne, H. J. *Faraday Discuss. Chem. Soc.*, in press.
- (213) Sudbo, Aa. S.; Schulz, P. A.; Shen, Y. T.; Lee, Y. T. *J. Chem. Phys.* **1978**, *69*, 2312.
- (214) Sudbo, Aa. S.; Schulz, P. A.; Grant, E. R.; Shen, Y. R.; Lee, Y. T. *J. Chem. Phys.* **1979**, *70*, 912.
- (215) Krajnovich, D.; Huisken, F.; Zhang, Z.; Shen, Y. R.; Lee, Y. T. *J. Chem. Phys.* **1982**, *77*, 5977.
- (216) Huisken, F.; Krajnovich, D.; Zhang, Z.; Shen, Y. R.; Lee, Y. T. *J. Chem. Phys.* **1983**, *78*, 3806.
- (217) Herman, I. P.; Magnotta, F.; Buss, R. J.; Lee, Y. T. *J. Chem. Phys.* **1983**, *79*, 1789.
- (218) Butler, L. J.; Buss, R. J.; Brudzynski, R. J.; Lee, Y. T. *J. Phys. Chem.* **1983**, *87*, 5106.
- (219) Krajnovich, D. J. Ph.D. Thesis, University of California, Berkeley, 1983. Lawrence Berkeley Laboratory publication LBL-15354; Berkeley. Schulz, P. A. Ph.D. Thesis, University of California, Berkeley, 1979.
- (220) Wodtke, A. M.; Hinsa, E. J.; Lee, Y. T. *J. Chem. Phys.* **1986**, *84*, 1044.
- (221) Schultz, A.; Cruse, H. W.; Zare, R. N. *J. Chem. Phys.* **1972**, *57*, 1354.
- (222) Stephenson, J. C.; King, D. S. *J. Chem. Phys.* **1978**, *69*, 1485.
- (223) Stephenson, J. C.; Bialkowski, S. E.; King, D. S. *J. Chem. Phys.* **1980**, *72*, 1161.
- (224) King, D. S.; Stephenson, J. C. *Chem. Phys. Lett.* **1985**, *114*, 461.
- (225) Rayner, D. M.; Hackett, P. A. *J. Chem. Phys.* **1983**, *79*, 5414.
- (226) Schmiedl, R.; Boettner, R.; Zacharias, H.; Meier, U.; Welge, K. H. *J. Mol. Struct.* **1980**, *61*, 271.
- (227) Schmiedl, R.; Meier, U.; Welge, K. H. *Chem. Phys. Lett.* **1981**, *80*, 495.
- (228) Rockney, B. H.; Grant, E. R. *J. Chem. Phys.* **1983**, *79*, 708.
- (229) King, D. S.; Stephenson, J. C. *Chem. Phys. Lett.* **1977**, *51*, 48.
- (230) Stephenson, J. C.; King, D. S. *J. Chem. Phys.* **1983**, *78*, 1867.
- (231) Hicks, K. W.; Lesiecki, M. L.; Riseman, S. M.; Guillory, W. A. *J. Phys. Chem.* **1979**, *83*, 1936.
- (232) Miller, C. M.; Zare, R. N. *Chem. Phys. Lett.* **1980**, *71*, 376. Miller, C. M.; McKillop, J. S.; Zare, R. N. *J. Chem. Phys.* **1982**, *76*, 2390. McKillop, J. S.; Gordon, R. J.; Zare, R. N. *J. Chem. Phys.* **1982**, *77*, 2895.
- (233) Lesiecki, M. L.; Guillory, W. A. *J. Chem. Phys.* **1978**, *69*, 4572.
- (234) Ashfold, M. N. R.; Hancock, G.; Hardaker, M. L. *J. Photochem.* **1980**, *14*, 85.
- (235) Renlund, A. M.; Reisler, H.; Wittig, C. *Chem. Phys. Lett.* **1981**, *78*, 40.
- (236) Beresford, J. R.; Hancock, G.; MacRobert, A. J.; Catanzarite, J.; Radhakrishnan, G.; Reisler, H.; Wittig, C. *Faraday Discuss. Chem. Soc.* **1983**, *75*, 211.
- (237) Quick, C. R.; Jr. Wittig, C. *J. Chem. Phys.* **1980**, *72*, 1694.
- (238) Ishikawa, Y.; Arai, S. *Rega Kagaku Kenkyu* **1982**, *4*, 84; *Chem. Abst.* **1983**, *98*, 135127p.
- (239) Rayner, D. M.; Hackett, P. A. *Isr. J. Chem.* **1984**, *24*, 232.
- (240) Dübal, H.-R.; Crim, F. F. *J. Chem. Phys.* **1985**, *83*, 3863.
- (241) Ashfold, M. N. R.; Atkins, C. G.; Hancock, G. *Chem. Phys. Lett.* **1981**, *80*, 1.
- (242) Hancock, G.; MacRobert, A. J. *Chem. Phys. Lett.* **1983**, *101*, 312.
- (243) Ashfold, M. N. R.; Atkins, C. G.; Hancock, G.; MacRobert, A. J. *Isr. J. Chem.* **1984**, *24*, 197.
- (244) Quack, M.; Sutcliffe, E.; Hackett, P.; Rayner, D. *Faraday Discuss. Chem. Soc.* in press. Hackett, P.; Rayner, D.; Quack, M.; Sutcliffe, E., manuscript in preparation.
- (245) Quack, M.; Seyfang, G. *J. Chem. Phys.* **1982**, *76*, 955.
- (246) Kolodner, P.; Kwok, H. S.; Black, J. G.; Yablonovitch, E. *Opt. Lett.* **1979**, *4*, 38.
- (247) Black, J. G.; Kolodner, P.; Schultz, M. J.; Yablonovitch, E.; Bloembergen, N. *Phys. Rev. A* **1979**, *19*, 704.
- (248) Gower, M. C.; Billman, K. W. *Appl. Phys. Lett.* **1977**, *30*, 514.
- (249) Fuß, W.; Cotter, T. P. *Appl. Phys.* **1977**, *12*, 265.
- (250) Lyman, J. L.; Rockwood, S. D.; Freund, S. M. *J. Chem. Phys.* **1977**, *67*, 4545.
- (251) Francisco, J. S.; Steinfeld, J. I.; Gilbert, R. G. *Chem. Phys. Lett.* **1981**, *82*, 311.
- (252) Francisco, J. S.; Lawrance, W. D.; Steinfeld, J. I.; Gilbert, R. G. *J. Chem. Phys.* **1982**, *86*, 724.
- (253) (a) Rice, S. A. In *Excited States*; Lim, E. C. Ed.; Academic: New York, 1975. (b) Robinson, P. J.; Holbrook, K. A. *Unimolecular Reactions*; Wiley: London, 1972. (c) Forst, W. *Theory of Unimolecular Reactions*; Academic: New York, 1973. (d) Tardy, D. S.; Rabinovitch, B. S. *Chem. Rev.* **1977**, *77*, 369. (e) Crim, F. F. *Annu. Rev. Phys. Chem.* **1984**, *35*, 657. (f) Smalley, R. E. *J. Phys. Chem.* **1982**, *86*, 3504. (g) Quack, M. In *Energy Transfer and Redistribution in Molecules*; Hinze, J., Ed.; Plenum: New York, 1983; p 493. (h) Troe, J. In *Physical Chemistry, an Advanced Treatise*, Jost, W. Ed.; Academic: New York, 1975; Vol. 6B. (i) Troe, J. *J. Chem. Phys.* **1983**, *79*, 6017. (j) Setzer, D. W. In *International Review of Science*; Polanyi, J. C.; Physical Chemistry Series One; Butterworths: London, 1972; Vol. 9. (k) Nikitin, E. E.; *Theory of Elementary Atomic and Molecular Processes in Gases*. Clarendon: Oxford, 1974. (l) Rice, O. K. *Statistical Mechanics, Thermodynamics and Kinetics*; Freeman: San Francisco, 1967. (m) Waage, E. V.; Rabinovitch, B. S. *Int. J. Chem. Kin.* **1971**, *3*, 105. (n) Robinson, P. J. In *Reaction Kinetics*, Ashmore, P. G., Ed.; The Chemical Society: London, 1975. (o) Benson, S. W. *Thermochemical Kinetics*; Wiley-Interscience: New York, 1976.
- (254) Quack, M.; Seyfang, G. *Chem. Phys. Lett.* **1982**, *93*, 442.
- (255) Simpson, T. B.; Black, J. G.; Burak, I.; Yablonovitch, E.; Bloembergen, N. *J. Chem. Phys.* **1985**, *83*, 628.
- (256) Whitten, E. Z.; Rabinovitch, B. S. *J. Chem. Phys.* **1963**, *38*, 2466.
- (257) (a) Haarhoff, P. C. *Mol. Phys.* **1963**, *6*, 337. (b) Haarhoff, P. C. *Mol. Phys.* **1963**, *7*, 101.
- (258) (a) Beyer, T.; Swinehart, D. F. *Commun. ACM* **1973**, *16*, 379. (b) Stein, S. E.; Rabinovitch, B. S. *J. Chem. Phys.* **1973**, *58*, 2348.
- (259) Dubs, M.; Harradine, D.; Schweitzer, E.; Steinfeld, J. I.; Patterson, C. *J. Chem. Phys.* **1982**, *77*, 3824.
- (260) Laux, L.; Foy, B.; Harradine, D.; Steinfeld, J. I. *J. Chem. Phys.* **1984**, *80*, 3499.
- (261) Harradine, D.; Foy, B.; Laux, L.; Dubs, M.; Steinfeld, J. I. *J. Chem. Phys.* **1984**, *81*, 4267.
- (262) Pummer, H.; Eggleston, J.; Bischel, W. K.; Rhodes, C. K. *Appl. Phys. Lett.* **1978**, *32*, 427.
- (263) Padrick, T. D.; Hays, A. K.; Palmer, M. A. *Chem. Phys. Lett.* **1980**, *70*, 63.
- (264) Fuss, W. *J. Phys. Chem.* **1982**, *86*, 731.
- (265) Bagratashvili, V. N.; Ionov, S. I.; Kuzmin, M. V.; Mishakov, G. V. *Chem. Phys. Lett.* **1985**, *115*, 149.
- (266) Bagratashvili, V. N.; Doljikov, V. S.; Letokhov, V. S.; Makarov, A. A.; Malyavkin, L. P.; Ryabov, E. A.; Silkis, E. G.; Vaivev, Yu. G. *Opt. Commun.* **1981**, *38*, 31.
- (267) (a) Mazur, E.; Burak, I.; Bloembergen, N. *Chem. Phys. Lett.* **1984**, *105*, 258. (b) Wang, J.; Chen, K. H.; Mazur, E. *Phys. Rev. A*, in press.
- (268) Fermi, E. *Z. Phys.* **1931**, *71*, 250.
- (269) (a) Doljikov, V. S.; Doljikov, Yu. S.; Letokhov, V. S.; Makarov, A. A.; Malonovsky, A. L.; Ryabov, E. A. *Chem. Phys.* **1986**, *102*, 155. (b) Doljikov, Yu. S.; Letokhov, V. S.; Makarov, A. A.; Malonovsky, A. L.; Ryabov, E. A. *Chem. Phys. Lett.* **1986**, *124*, 304.
- (270) Kudriavtsev, Yu. A.; Letokhov, V. S. *Chem. Phys.* **1980**, *50*, 353.

- (271) Herzog, B.; Hippler, H.; Kang, L.; Troe, J. *Chem. Phys. Lett.* **1985**, *120*, 124.
- (272) Presser, N.; Mao, C. R.; Moriarty, R. M.; Gordon, R. J. *J. Chem. Phys.* **1983**, *78*, 6021.
- (273) Zellweger, J.-M.; Brown, T. C.; Barker, J. R. *J. Phys. Chem.* **1986**, *90*, 461.
- (274) Barfknecht, A. T.; Brauman, J. I. *J. Chem. Phys.* **1986**, *84*, 3870.
- (275) Judd, O. P. *J. Chem. Phys.* **1979**, *71*, 4515.
- (276) (a) Kwok, H. S.; Yablonovitch, E. *Rev. Sci. Instrum.* **1975**, *46*, 814. (b) Kwok, H. S.; Yablonovitch, E.; Bloembergen, N. *Phys. Rev. A* **1981**, *23*, 3094.
- (277) Mukherjee, P.; Kwok, H. S. *Appl. Phys. Lett.* **1984**, *44*, 180.
- (278) Mukherjee, P.; Kwok, H. S. *Chem. Phys. Lett.* **1984**, *111*, 33.
- (279) Mukherjee, P.; Kwok, H. S. *J. Chem. Phys.* **1986**, *84*, 1285.
- (280) Corkum, P. B. *Opt. Lett.* **1983**, *8*, 514.
- (281) Corkum, P. B. *IEEE J. Quant. Electron.* **1985**, *QE-21*, 216.
- (282) McAlpine, R. D.; Evans, D. K. *Faraday Discuss. Chem. Soc.* **1983**, *75*, 261. Chin, S. E.; Evans, D. K.; McAlpine, R. D.; Selander, W. N. *Appl. Opt.* **1982**, *21*, 65.
- (283) Basov, N. G.; Belenov, E. M.; Danilychev, V. A.; Suchkov, A. F. *Sov. J. Quantum Electron.* **1971**, *1*, 306.
- (284) Taylor, R. S.; Alcock, A. J.; Sarjeant, W. J.; Leopold, K. E. *IEEE J. Quantum Electron.* **1979**, *QE-15*, 113.
- (285) Alimpiev, S. S.; Karlov, N. V.; Prokhorov, A. M.; Sartakov, B. G.; Khokhlov, G. M.; Shtarkov, A. L. *Opt. Commun.* **1979**, *31*, 309.
- (286) Borsella, E.; Fantoni, R.; Giardini-Guidoni, A.; Adams, D. R.; Cantrell, C. D. *Chem. Phys. Lett.* **1983**, *101*, 86.
- (287) del Bello, U.; Borsella, E.; Fantoni, R.; Giardini-Guidoni, A.; Cantrell, C. D. *Chem. Phys. Lett.* **1985**, *114*, 467.
- (288) Snels, M.; Larciprete, R.; Fantoni, R.; Borsella, E.; Giardini-Guidoni, A. *Chem. Phys. Lett.* **1985**, *122*, 480.
- (289) Lupo, D.; Quack, M. Presented at the Topical Meeting on Multiphoton Processes, Trieste-Miramare, Italy, 1985; *Chem. Phys. Lett.* **1986**, *130*, 371.
- (290) (a) Lavigne, P. *Opt. Commun.* **1977**, *22*, 75. (b) Kleiner-manns, C.; Wagner, H. G. Z. *Phys. Chem. (Munich)* **1979**, *118*, 1. (c) Slater, R. C.; Parks, J. H. *Chem. Phys.* **1979**, *60*, 275.
- (291) (a) Duperrex, R.; van den Bergh, H. *J. Chem. Phys.* **1979**, *71*, 3613. (b) Duperrex, R.; van den Bergh, H. *J. Mol. Structure* **1980**, *61*, 291.
- (292) Rayner, D. M.; Hackett, P. A. *Chem. Phys. Lett.* **1984**, *110*, 482.
- (293) (a) Au, Mei Kuen; Hackett, P. A.; Humphries, M.; John, P. *Laser Chem.* **1984**, *4*, 275. (b) Au, Mei Kuen; Hackett, P. A.; Humphries, M.; John, P. *Appl. Phys. B* **1984**, *33*, 43.
- (294) Evseev, A. V.; Letokhov, V. S.; Puzetzy, A. A. In *Recent Advances in Molecular Reaction Dynamics*; Vetter, R., Vigué, J., Eds. Editions de CNRS: Paris, 1986.
- (295) Pochon, E.; Weston, R. E., Jr.; Flynn, G. W. *J. Phys. Chem.* **1985**, *89*, 86.
- (296) Rabinowitz, P.; Stein, A.; Brickman, R.; Kaldor, A. *Appl. Phys. Lett.* **1979**, *35*, 739.
- (297) Bernardini, M.; Ferrario, A.; Giorgi, A.; Marchetti, S.; Palucci, A. ENEA publication RT/TIB/84/30; ENEA: Rome, Italy, 1984.
- (298) Perry, B.; Brickman, R. O.; Stein, A.; Treacy, E. B.; Rabinowitz, P. *Opt. Lett.* **1980**, *5*, 288.
- (299) Majima, T.; Tashiro, H.; Midorikawa, K.; Takami, M. *Chem. Phys. Lett.* **1985**, *121*, 65.
- (300) (a) Geraedts, J.; Snels, M. N. N.; Stolte, S.; Reuss, J. *Chem. Phys. Lett.* **1984**, *106*, 377. (b) Knippers, W.; Luijks, G.; Stolte, S.; Reuss, J. *Chem. Phys. Lett.* **1984**, *109*, 532.
- (301) Lester, M. I.; Casson, L. M.; Spector, G. B.; Flynn, G. W.; Bernstein, R. B. *J. Chem. Phys.* **1984**, *80*, 1490.
- (302) Sudbo, A. S.; Schulz, P. A.; Krajnovich, D. J.; Lee, Y. T.; Shen, Y. R. *Opt. Lett.* **1979**, *4*, 219.
- (303) Houston, P. *Chem. Phys.* **1978**, *35*, 317.
- (304) (a) Bado, P.; van den Bergh, H. *J. Chem. Phys.* **1978**, *68*, 4188. (b) Duperrex, R.; van den Bergh, H. *Chem. Phys.* **1979**, *40*, 275. (c) Baldwin, A. C.; van den Bergh, H. *J. Chem. Phys.* **1981**, *74*, 1012.
- (305) Quack, M.; Troe, J.; In *Gas Kinetics and Energy Transfer*; Ashmore, P. G.; Donovan, R. J., Eds.; The Chemical Society: London, 1977; Vol. 2, p 175.
- (306) Pechukas, P.; Light, J. C. *J. Chem. Phys.* **1965**, *42*, 3281.
- (307) Quack, M.; Seyfang, G., unpublished results.
- (308) Quack, M.; Seyfang, G. *Ber. Bunsenges. Phys. Chem.* **1982**, *86*, 504.
- (309) Lupo, D. W.; Quack, M. *Faraday Discuss. Chem. Soc.*, in press.
- (310) Plum, C. N.; Houston, P. L. *Chem. Phys.* **1980**, *45*, 159.
- (311) Quack, M.; Seyfang, G. *Chem. Phys. Lett.* **1981**, *84*, 541.
- (312) Lesiecki, M. L.; Guillory, W. A. *J. Chem. Phys.* **1977**, *66*, 4317.
- (313) (a) Karny, Z.; Zare, R. N. *Chem. Phys.* **1977**, *23*, 321. (b) Naaman, R.; Zare, R. N. *Faraday Discuss. Chem. Soc.* **1979**, *67*, 242.
- (314) Olszyna, K. J.; Grunwald, E.; Keehn, P. M.; Anderson, S. P. *Tetrahedron Lett.* **1977**, *19*, 1609.
- (315) Hall, R. B.; Kaldor, A. *J. Chem. Phys.* **1979**, *70*, 4127.
- (316) Woodin, R. L.; Hall, R. B.; Meyer, C. F.; Kaldor, A. In *Advances in Laser Spectroscopy*, Garetz, B. A., Lombardi, J. R., Eds.; Heyden: London, 1982; Vol. 1.
- (317) Woodin, R. L.; Hall, R. B.; Meyer, C. F.; Kaldor, A. *Proc. Int. Conf. Lasers* **1982**, 945.
- (318) Brenner, D. M. *Chem. Phys. Lett.* **1978**, *57*, 357.
- (319) Brenner, D. M. *J. Phys. Chem.* **1982**, *86*, 41.
- (320) Rosenfeld, R. N.; Brauman, J. I.; Barker, J. R.; Golden, D. M. *J. Am. Chem. Soc.* **1977**, *99*, 8063.
- (321) Back, M. H.; Back, R. A. *Can. J. Chem.* **1979**, *57*, 1511. Back, R. A. *Can. J. Chem.* **1982**, *60*, 2542.
- (322) Hill, G. A.; Grunwald, E.; Keehn, P. *J. Am. Chem. Soc.* **1977**, *99*, 6521.
- (323) Hudgens, J. W. *J. Chem. Phys.* **1978**, *68*, 777.
- (324) Morrison, R. J. S.; Loring, R. F.; Farley, R. L.; Grant, E. R. *J. Chem. Phys.* **1981**, *75*, 148.
- (325) Quack, M.; Sutcliffe, E. *Chem. Phys. Lett.* **1984**, *105*, 147.
- (326) Thunemann, K. H.; Peyerimhoff, S. D.; Buenker, R. J. **1978**, *70*, 432.
- (327) Wright, J. S.; Shih, S.; Buenker, R. J. *Chem. Phys. Lett.* **1980**, *75*, 513.
- (328) Varandas, A. J. C.; Murrell, J. N. *Chem. Phys. Lett.* **1982**, *88*, 1.
- (329) Raffel, B.; Warnatz, J.; Wolfrum, J. *Appl. Phys. B* **1985**, *37*, 189.
- (330) Hollenstein, H.; Quack, M.; Thöne, H. J. *Mol. Phys.* **1985**, *56*, 463.
- (331) Schwebel, A.; Brestel, M.; Yogev, A. *Chem. Phys. Lett.* **1984**, *107*, 579.
- (332) Benmair, R. M. J.; Yogev, A. *Chem. Phys. Lett.* **1983**, *95*, 72.
- (333) Bigeleisen, J.; Hammond, W. B.; Tuccio, S. *Nucl. Sci. Eng.* **1983**, *83*, 473.
- (334) Quack, M.; Troe, J. *Theor. Chem. (N.Y.)* **1981**, *6B*, 199.
- (335) Bagratashvili, V. N.; Dolzhikov, V. S.; Letokhov, V. S.; Markarov, A. A.; Ryabov, E. A.; Tykht, V. V. *Sov. Phys. JETP* **1979**, *50*, 1075.
- (336) Bagratashvili, V. N.; Dolzhikov, V. S.; Letokhov, V. S.; Ryabov, E. A. In *Laser Induced Processes in Molecules*; Smith, S. D., Eds.; Springer-Verlag: Berlin, 1979; p 179.
- (337) Quack, M.; Sutcliffe, E. *Isr. J. Chem.* **1984**, *24*, 204.
- (338) Jost, W. Z. *Naturforsch. A: Astrophys., Phys. Phys. Chem.* **1947**, *2a*, 159.
- (339) Jost, W. Z. *Phys. Chem. (Munich)* **1950**, *195*, 317.
- (340) Pritchard, H. O.; Vatsya, S. T. *J. Chem. Phys.* **1982**, *76*, 1024.
- (341) Gear, C. W. *Numerical Initial Value Problems in Ordinary Differential Equations*; Prentice Hall: Englewood Cliffs, 1971.
- (342) Oref, I. *J. Chem. Phys.* **1982**, *77*, 1253.
- (343) Meath, W. J.; Power, E. A. *Mol. Phys.* **1984**, *51*, 585.
- (344) Moloney, J. V.; Meath, W. J. *Mol. Phys.* **1976**, *31*, 1537. Thuraisingham, R. A.; Meath, W. J. *Mol. Phys.*, in press.
- (345) Quack, M. Lectures on IR-Photochemistry at the Topical Meeting on Multiphoton Processes, Trieste-Miramare Italy, 1985, unpublished.
- (346) Mittasch, Alwin. *Geschichte der Ammoniaksynthese*. Weinheim, 1951.
- (347) Suhling, Lothar, *Fridericiana*; Engelhardt und Bauer: Karlsruhe, 1984; p 31.
- (348) Haber, Fritz. *Thermodynamik Technischer Gasreaktionen*; München, 1905; p 187ff.
- (349) Haber, Fritz, Nobel lecture, 1918.
- (350) van't Hoff, J. H. *Vorlesungen über Theoretische und Physikalische Chemie*; Vieweg Verlag: Braunschweig, 1898.
- (351) Nernst, W. *Nachr. Ges. Wiss. Göttingen, Math-Phys. Kl.* **1906**, *1*, 1.
- (352) Mendelssohn, Kurt. *Walter Nernst und seine Zeit*; Weinheim, 1976.
- (353) Hackett, P. A., private communication, 1986.
- (354) Angelié, C.; Capitini, R.; Girard, P. *Laser Chem.*, in press.
- (355) Brumer, P.; Shapiro, M. *Faraday Discuss. Chem. Soc.*, in press.