

The Molecular Mechanism of Retention in Reversed-Phase Liquid Chromatography

JOHN G. DORSEY*

Department of Chemistry, University of Florida, Gainesville, Florida 32611

KEN A. DILL

Departments of Pharmaceutical Chemistry and Pharmacy, University of California, San Francisco, California 94143

Received June 27, 1988 (Revised Manuscript Received October 5, 1988)

Contents

I. Introduction	331
II. Modern RPLC Phases	331
1. Monomeric Phases	332
2. Polymeric Phases	333
3. Polymer Resin Phases	335
4. Chain Length and Functionality	335
III. Theory of the Retention Mechanism	335
1. Partitioning	336
2. Solvophobic Theory	338
3. Adsorption	339
IV. Effects of the Interphase Chain Organization	339
V. Experimental Tests of the Molecular Organization of Stationary Phases	342
VI. Conclusions	344
VII. Literature Cited	345

I. Introduction

The term "reversed-phase" chromatography seems at first inappropriate for what is by far the most popular mode of modern liquid chromatography. Estimates of the popularity of the technique range from 57% of all analytical chromatography¹ to as high as 80-90%.² The term itself can be traced to Howard and Martin in 1950.³ In attempting the separation of long-chain fatty acids they realized that the "normal" mode of chromatography, using a polar stationary phase and non-polar mobile phase, would not work, as the hydrophobic compounds had too little retention to effect a separation. They were able to treat Kieselguhr with dimethyldichlorosilane vapor and then coat this hydrophobic support with a nonpolar liquid stationary phase. Both the polarity of the phases and the respective elution order of solutes were reversed from traditional chromatographic systems, and they christened the technique "reversed-phase" partition chromatography.

The popularity of reversed-phase liquid chromatography (RPLC), as practiced today, can be attributed to the development of chemically stable, microparticulate bonded phases that provide rapid mass transfer and a high degree of reproducibility. Attempts to utilize liquid-liquid chromatography, with a liquid stationary phase physically coated on an inert support, were rapidly abandoned with the introduction of commercially available bonded phases. Interesting perspectives on the early development of bonded phases for modern liquid chromatography can be found in a book devoted to the history of liquid chromatography.⁴

H. A. Laitinen, in an editorial in *Analytical Chemistry*, described the seven ages of an analytical method from the birth of an idea to the ultimate replacement of the method by newer techniques.⁵ The fourth phase he described as "...detailed studies of principle and mechanisms are pursued with the aid of improved instrumentation. This represents the stage at which the method matures as an accepted procedure in competition and cooperation with other approaches. This stage represents the crest of analytical research as distinguished from instrumentation research." This most clearly describes the present status of reversed-phase liquid chromatography. Many methods of investigation are being brought to bear on the problem of understanding the molecular mechanism of retention of RPLC. These range from spectroscopic studies, including UV-visible, IR, NMR, fluorescence, and others, to thermal methods, to neutron scattering, to chromatographic methods themselves. Experimental studies alone are not enough. The cooperation of theorists and experimentalists is leading to dramatic advances in the understanding of the retention process.

The goal of this review is to critically assess the current understanding of retention of small molecules in reversed-phase chromatography from both a theoretical and experimental perspective. We first discuss the synthetic methodologies for the preparation of reversed-phase stationary phases and deal next with the partitioning processes and stationary-phase structural details.

II. Modern RPLC Phases

Reversed-phase liquid chromatography as currently practiced utilizes a nonpolar stationary phase and a polar mobile phase. The nonpolar stationary phases are most often spherical silica particles that have been surface derivatized with hydrocarbon chains. The wide variability in retention and separation with columns from different manufacturers is a result of differences both in the starting silica and in the methods of surface derivatization. We begin with a review of synthetic procedures and the resulting implications for understanding retention.

The synthetic technology for preparing reversed-phase stationary phases has advanced greatly since the introduction of the first bonded phases. Early problems of a lack of reproducibility from column to column, even from the same manufacturer, have largely been solved.



John G. Dorsey received his Ph.D. in Analytical Chemistry from the University of Cincinnati in 1979, with T. W. Gilbert. He was then appointed Assistant Professor of Chemistry at the University of Florida and was promoted to Associate Professor in 1985. His research interests are in the areas of fundamental liquid chromatography, analytical applications of micelles and organized media, flow injection analysis, and old Bordeaux wines. He has about 40 publications in these areas and serves on the Editorial Review Boards of *Analytical Letters*, *BioChromatography*, and the *Journal of Liquid Chromatography*.



Ken Dill is currently Associate Professor in the Departments of Pharmaceutical Chemistry and Pharmacy at the University of California, San Francisco, and Adjunct Associate Professor of Pharmaceutics at the University of Utah. After receiving S.B. and M.S. degrees in the Mechanical Engineering Department at MIT, he received his Ph.D. in 1978 from the Biology Department at the University of California, San Diego, with Professor Bruno H. Zimm. He did postdoctoral work with Professor Paul J. Flory in the Chemistry Department at Stanford University. He then served on the chemistry faculty for about 2 years at the University of Florida, before moving to his present position at UCSF. His research interests have been in the statistical mechanics of biological and chain molecules, particularly (i) chains at interfaces, including membranes, micelles, and other interfacial phases, and (ii) the folding and stability of globular proteins.

This irreproducibility was a result of many factors, including poor control of the physical and chemical properties of the initial silica as well as the bonding reaction. Realization of the importance of the starting silica material has led many column manufacturers to now make their own starting silica. It is now generally assumed that commercial columns from the same manufacturer should give retention variations of <5%. Variations from one manufacturer to another, however, may be dramatic. Differences in synthetic methodology and in the starting silica both play a role in the retention properties. It is not within the scope of this review to discuss the morphology and characteristics of the silica substrate. An excellent treatise by Unger is available.⁶ A comprehensive review of stationary-phase

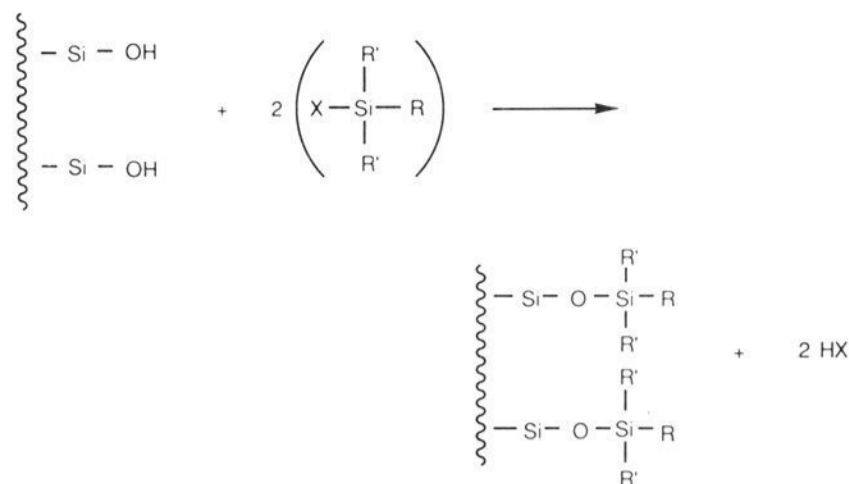

Figure 1. Generalized bonding reaction for derivatization of silica surface by alkylsilanes. X = leaving group. R' and R are any desired functionalities; R' is typically methyl, and R is C₈, C₁₈, etc.

synthesis has recently been published by Sander and Wise.⁷

1. Monomeric Phases

By far the most popular synthetic scheme for the preparation of RPLC stationary phases involves the aptly named "monomeric reaction". Here a functionalized silane with a single leaving group is reacted with silica to form a siloxane bridge. The generalized reaction is depicted in Figure 1. The primary advantage of the monomeric stationary phases is that they provide a very well-defined single layer of coverage of the silica surface. With careful control of the reaction conditions the end product is very reproducible in terms of bonding density of the grafted hydrocarbon groups. The most popular leaving group is chloride, although methoxy, ethoxy, and dimethylamino groups, among others, have also been used. The most common reaction then involves slurring the starting silica with an alkyldimethylchlorosilane in a suitable solvent such as toluene along with an "activator" or scavenger base and refluxing for several hours. With C₈ or C₁₈ functionalities this generally yields a surface coverage of between 2.5 and 3.0 $\mu\text{mol}/\text{m}^2$. There are generally assumed to be a maximum of about 8 $\mu\text{mol}/\text{m}^2$ of hydroxyl sites on the surface of activated silica,⁶ so many residual hydroxyl groups are left. They are accessible to solutes during the chromatographic process and may lead to tailing and poor efficiency, especially for basic solutes. For this reason, many manufacturers use a second reaction step with a trimethylsilane to "end cap" the remaining hydroxyl sites. These phases are often advertised as "maximum coverage" stationary phases, yet unfortunately this still does not react all of the available sites, and interaction of basic compounds with these sites still occurs.

Kohler and Kirkland et al.^{8,9} have studied the problems associated with these remaining hydroxyl sites and have found that undesired adsorption of basic compounds and the low hydrolytic stability of alkyl bonded-phase ligands can be attributed to the existence of isolated, non-hydrogen-bridged, highly acidic SiOH groups on the silica surface. They argue that it is desirable that the silica support for stable reversed-phase packings with low adsorptivity for basic compounds should contain the highest, and not the lowest, number of homogeneously distributed, associated SiOH groups. They prepared silica supports such as these and found

markedly lowered adsorptivity for basic compounds and significantly improved hydrolytic stability of bonded-phase ligands.⁹

There has been much effort devoted to increasing the surface coverage, or bonding density, of these monomeric phases. As originally described by Kovats¹⁰ the dimethylamino leaving group appears to provide higher surface coverage than any other group, with values of 4.0–4.4 $\mu\text{mol}/\text{m}^2$ being reported. This silane has just recently become commercially available and has been tested by only a few groups. Buszewski et al.^{11–13} have studied the role of the activator by using dimethylamino and other leaving groups and have reported reproducible phases of about 4.2 $\mu\text{mol}/\text{m}^2$ using an activator with a $\text{p}K_a$ of 8.3. Kinkel and Unger¹⁴ have studied the role of the solvent and base in these silanization reactions and have reported that the solvent appears to exert a more pronounced effect than the base in a given reaction. They also recommended the use of a base with a $\text{p}K_a$ of about 7. Mechanistic studies of these types of reactions have shown that two molecules of base attack one molecule of silane, activating the Si–X bond such that a reactive intermediate and a hydrohalide are formed.¹⁵ Formation of this reactive intermediate greatly increases the kinetics of the bonding reaction; indeed, the addition of the acid acceptor catalyst results in approximately 90% of the total conversion taking place within the first hour of the reaction.¹⁴ It is clear that much remains to be understood about the mechanism of these bonding reactions. An interesting and useful study would be the application of a chemometric optimization to the variables in the synthetic process.

Both Sander and Wise¹⁶ and Sands et al.¹⁷ have studied the effect of pore diameter and surface treatment of the silica on the bonding reaction. Sands et al.¹⁷ showed that bonding density increases with pore diameter but that resolution of small molecules decreased sharply with increasing pore diameter and pore volume. These effects are likely due to the reduced surface area and resulting reduction in stationary-phase volume of the large-pore materials.

At high bonding densities, further increase in coverage is made extremely difficult by steric constraints. Every incremental increase in bonding density becomes successively more difficult as unreacted alkylsilane must partition into the already densely bonded phase to undergo further reaction. This steric hindrance was reduced by Burke and co-workers¹⁸ through the use of a dihydrochlorosilane, which is much less bulky than the common dimethylsilanes. They also achieved densities of around 4 $\mu\text{mol}/\text{m}^2$, but again, this required specially synthesized silanes. Other attempts to increase bonding density have utilized unique reaction processes. Khong and Simpson¹⁹ used fluidized bed technology with traditional reactants. Blain and Hartwick²⁰ used a supercritical fluid as the reaction solvent, and Sentell and co-workers²¹ have reported the use of ultrasound to drive the reaction at ambient and subambient temperatures.

The chromatographic advantages of higher bonding densities are severalfold. First, the shielding prevents solute access to the surface and thus minimizes retention due to adsorption on the silica. Second, shielding protects against base hydrolysis of the silica, increasing

the stability of the stationary phase. Also, increased bonding density may lead to higher chromatographic selectivity; there is some evidence that the improved selectivity for certain compounds offered by polymeric phases is simply a function of the bonding density (see below). Moreover, the molecular organization of densely bonded phases resembles that of biomembranes and may have application as model systems.

Although many statements exist in the literature about correlations between chromatographic properties and carbon content of the bonded phase, this is not the relevant parameter. As Unger et al.²² pointed out early in the history of bonded phases, carbon content alone is often misleading because of differences in the surface area of the original silica, which results in different surface densities of the bonded alkyl groups. As the surface area of various chromatographic silicas ranges from about 60 to several hundred square meters per gram, the actual surface density of the bonded alkyl chains must be calculated for relevant comparisons among different stationary phases. This surface density is most often described in units of $\mu\text{mol}/\text{m}^2$, but careful consideration is also necessary here before accepting literature values. The relevant surface area should be the area of the *underivatized* silica, as this is where the bonding reaction occurs and is the point of attachment of the alkyl chains. This then gives the relevant chain density. Some workers have reported the area of the derivatized silica, which may be 30–70% lower and which will give highly inflated surface densities.

2. Polymeric Phases

If a di- or trifunctional silane is used in the synthetic scheme, a more complex surface chemistry may result. In this case, there are a number of possibilities for reaction sites. The silane may simply anchor at two (or three) silica surface sites and still yield only a single layer of surface coverage. More likely, however, one or more of the leaving groups on the silane will hydrolyze and then react with other leaving groups to form a polymeric network extending out from the silica surface. This polymerization reaction may occur in solution before bonding to the silica surface, after the silane has already been bonded to the surface, or both. Both the extent of cross-linking and the amount of silane bonded to the surface are very sensitive to the reaction conditions. Early work with polymeric phases led to a belief that they were irreproducible and generally showed poor stationary-phase mass transfer characteristics. The reactions are, however, simpler to run, and for this reason polymeric phases have continued to be commercially available. While the polymeric phases do result in a higher carbon content, or more bonded "mass", they are still not free from the secondary interaction of solutes with residual hydroxyl sites. While the silica surface may be totally protected, hydroxyl sites will often occur on the "last" silanes in the polymeric network from hydrolysis of the leaving groups.

Sander and Wise²³ have shown that polymeric phases can be made reproducibly, and may have certain chromatographic advantages, when reaction conditions are carefully controlled. Using a single lot of silica and carefully controlling the water content in the reaction mixture, they reported the preparation of a polymeric phase with a relative standard deviation of only 0.96%

in surface coverage over four trials. They also described the synthesis of "oligomeric" phases that were the result of a controlled, sequential polymerization. The oligomeric phases have a carbon content intermediate between that of the traditional monomeric and polymeric phases. They also compared the three types of phases (monomeric, polymeric, and oligomeric) for their chromatographic selectivity toward polyaromatic hydrocarbons. They found dramatic increases in selectivity with increasing carbon content (and thus probably bonding density) of the phases, and for some of the polymeric columns they found base-line resolution for 16 priority pollutant polycyclic aromatic hydrocarbons (PAHs) (NBS SRM 1647; see Figure 2). Wise and Sander²⁴ have extensively studied the separation of polycyclic aromatic hydrocarbon isomers on polymeric C₁₈ phases of various chain densities. They noted that the shape selectivity observed for high-density polymeric phases is similar to that observed for liquid crystalline phases used in gas chromatography and suggested that polymeric phases must then be more "ordered" than monomeric phases. Rogers et al.²⁵ compared monomeric and polymeric C₁₈ phases by ¹³C NMR and also concluded that the polymeric phases must be more "ordered". This would be expected if the surface densities were higher, as discussed below.

Care must be taken in describing the surface structure of these polymeric phases. As the polymerization reaction proceeds, it is possible for a reactive silane molecule to anchor at a point more distant from the silica surface. Since the degree of polymerization is almost never known, the surface density numbers should be viewed only as a rough indication of true chain density. Sander and Wise²³ stated that "the use of surface coverage values to calculate interchain distances is probably not justified for polymeric phases".

With both polymeric and monomeric phases commercially available, problems may arise in knowing what is offered by individual manufacturers. Too often the column manufacturers do not reveal the bonding chemistry used, and the user is left to guess the nature of the column. Several tests exist that give reasonable knowledge about the stationary-phase organization and bonding chemistry. Sander and Wise²³ devised a simple empirical test to gauge the relative monomeric or polymeric "character" of a phase. The elution order of a three-component PAH mixture, phenanthro[3,4-*c*]phenanthrene (PhPh), 1,2:3,4:5,6:7,8-tetrabenzonaphthalene (TBN), and benzo[*a*]pyrene (BaP), was found to be dependent on the type of phase and surface coverage. With mobile-phase conditions of 85% acetonitrile/water, monomeric C₁₈ phases on widely differing silica substrates produced the elution order BaP, PhPh, TBN. On the oligomeric series the three compounds eluted in the order PhPh, BaP, TBN, whereas on polymeric phases that are moderately or heavily loaded, they eluted in the order PhPh, TBN, BaP. Sander and Wise suggested that the elution order of this mixture could be used to screen unknown phases both for their synthetic type (monomeric vs polymeric) and also for their column selectivity toward more complex PAH mixtures. Figure 2 shows a typical chromatogram with each of the column types.

Fazio and co-workers²⁶ developed a chemical characterization test using hydrofluoric acid digestion of a

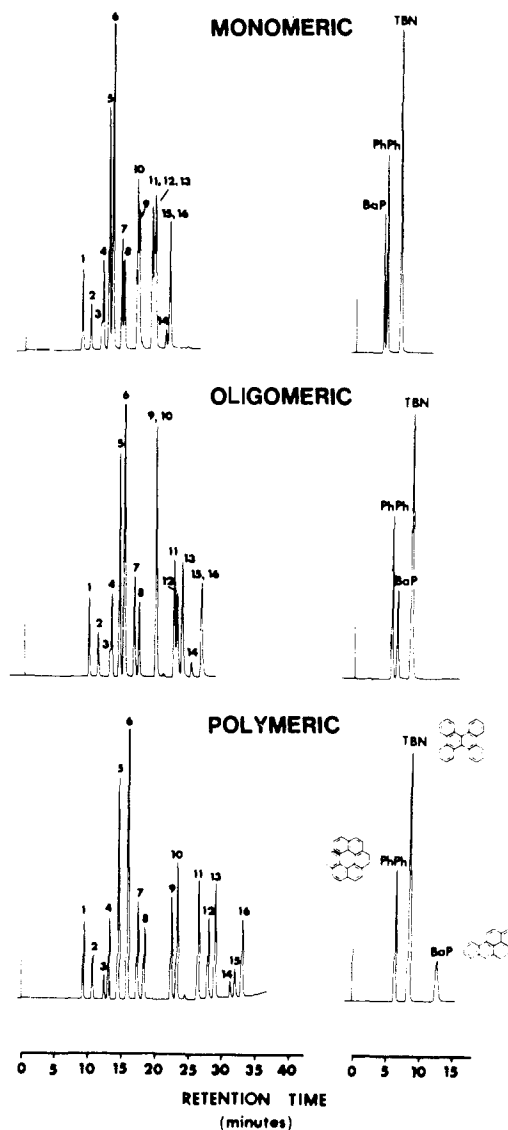

Figure 2. Separation of 16 polycyclic aromatic hydrocarbons (NBS SRM 1647) on representative monomeric, oligomeric, and polymeric phases.²³ Separation of the sixteen-component mixture was performed by using gradient elution, 40–100% acetonitrile in water over 30 min at 2 mL/min. The three-component mixture was run isocratically at 85% acetonitrile/water. The elution order of benzo[*a*]pyrene (BaP), phenanthro[3,4-*c*]phenanthrene (PhPh), and 1,2:3,4:5,6:7,8-tetrabenzonaphthalene (TBN) is indicative of phase type. Component identification: (1) naphthalene, (2) acenaphthylene, (3) indeno[1,2,3-*cd*]pyrene, (4) fluorene, (5) phenanthrene, (6) anthracene, (7) fluoranthene, (8) pyrene, (9) benz[*a*]anthracene, (10) chrysene, (11) benzo[*b*]fluoranthene, (12) benzo[*k*]fluoranthene, (13) benzo[*a*]pyrene, (14) dibenz[*a,h*]anthracene, (15) benzo[*ghi*]perylene, (16) indeno[1,2,3-*cd*]pyrene. Reprinted from ref 23; copyright 1984 American Chemical Society.

sample of the phase and subsequent gas chromatographic analysis of the digestion products. This method was shown to be highly quantitative, allowing unequivocal identification of phases prepared from di- and trireactive silanes and allowing determination of carbon content and subsequent calculation of bonding density, provided the surface area of the silica is known. Lüllmann et al.²⁷ developed a similar process, treating the derivatized silicas with fused alkali in order to cleave the ligands, followed by analysis using gas chromatography. Stationary phases prepared with trifunctional silanes yielded mainly the free alkanes, difunctional silanes yielded isomers of cyclic tri- and tetraalkylsiloxanes, and monofunctional silanes yielded tri-

alkylsilanols and hexaalkyldisiloxanes.

Both pyrolysis GC²⁸ and pyrolysis-mass spectrometry²⁹ have also been applied to the characterization of bonded phases. The use of mono-, di-, or trifunctional silanes is discernible, as well as whether or not the column is end-capped.

3. Polymer Resin Phases

In an attempt to improve the poor pH stability of surface-derivatized silica, polymer adsorbents have been developed that give a separation similar to those from traditional reversed-phase stationary phases. These resin phases are often styrene-divinylbenzene copolymers, and their use as reversed-phase stationary phases has been recently discussed.³⁰ They are generally more retentive than traditional reversed-phase stationary phases and provide lower efficiency, but are stable over a pH range of 1–12. More recently, a commercially available resin phase has been introduced that has pendant C₁₈ groups; this phase should behave similarly to silica-based phases. These resin phases will not be discussed further in this review.

4. Chain Length and Functionality

The conditions of reversed-phase chromatography require a nonpolar stationary phase, but this condition can be met by many different ligands. In fact, there are commercially available columns of at least C₁, C₂, C₄, C₈, C₁₈, phenyl, and cyano functionalities, where the carbon numbers refer to the length of a fully saturated hydrocarbon chain. While the cyano phases are not highly nonpolar, they can behave in a reversed-phase manner. The question then arises as to how these different phases affect retention and the retention mechanism.

Antle et al.^{31,32} have studied variations in retention and selectivity among different reversed-phase columns. They showed that differences in solute retention were correlated with three effects: (i) the effective phase ratio of the column as measured by the average retention of all solutes; (ii) the "polarity" of the bonded phase; and (iii) the dispersion solubility parameter of the bonded phase. The phase ratio of the column is a function of the chain length, the bonding density, and the surface area of the silica and is almost never reported. This alone may account for many discrepancies in the literature concerning the effects of chain length.

The effects of length of the bonded stationary phase chains have been studied since early in the development of HPLC^{33–35} but are only recently becoming more fully understood through the assistance of statistical mechanical theory. According to Melander and Horvath,³⁴ the principal difference in methylene-group selectivity is found in comparison of short chains (C₁ or C₂) with longer chains (C₈ or C₁₈). It is anticipated from theory (see below) that solute adsorption should be the dominant mechanism of retention for short chains, whereas solute partitioning should generally be the dominant mechanism for longer chains. More subtle effects are also to be expected. For example, Krstulovic et al.³⁵ have observed that methylene-group selectivity increases with chain length of the bonded phase. Similarly, Sander and Wise have recently shown that selectivity for a series of PAH compounds increases with

chain length for both monomeric and polymeric phases.³⁸ These differences may be due to differences in the phase ratio, to differences in molecular organization (ordering) of the chains, or both.

The choice of functional group is of interest both to those studying the fundamental mechanisms of retention and to practicing chromatographers. Antle et al.^{31,32} have suggested the use of C₈, cyano, and phenyl columns for maximum range of column selectivity. These columns have independently been found to provide a wide range of selectivity for the separation of PTH-amino acids.³⁹ Cooper and Lin⁴⁰ used solutes and solvents at the apices of Snyder's solvent selectivity triangle,⁴¹ which categorizes solvents according to their dipole interactions and hydrogen bond donating and accepting abilities, to systematically characterize retention on these three types of columns. They concluded that differences in retention are due primarily to differences in the basic group selectivities of the three phases, but these differences were found not to affect the retention of nonbasic solutes.

III. Theory of the Retention Mechanism

Chromatographic retention involves a process of solute transfer from a mobile phase into or onto a stationary phase. The association of the solute with the stationary phase can involve partitioning, adsorption, or both. For our purposes, the distinction is that "partitioning" implies that the solute is approximately fully embedded within the stationary phase, whereas "adsorption" implies that the solute is in surface contact with the stationary phase and is not fully embedded. In either case, transfer is characterized by an exchange of the environment at the surface of the solute molecule: solute is initially surrounded by neighboring mobile-phase molecules and is finally surrounded, fully or partially, by neighboring molecules of the stationary phase.

The experimentally observed retention factor, $k' = K\Phi$, is the product of an equilibrium constant K for this solute-transfer process multiplied by the phase ratio, Φ , the ratio of the volumes of stationary and mobile phases. Because the stationary phase is generally <30 Å in thickness, wherein fluctuations and the ratio of interface to volume are large, precise definition of the phase ratio is not as unambiguous as it would be for macroscopic bulk phases, where the interface is negligible. Thus the optimal experimental determination of the phase ratio has been a matter of much disagreement. The precise microscopic definition of the phase ratio can only follow from statistical mechanical theory for the molecular origins of the retention process. In that way, it has recently been shown that the appropriate volume of the stationary phase is simply that of the sum of the specific molecular volumes of the grafted hydrocarbon chains (*not* including intercalated solvent) if transfer occurs by partitioning, whereas the phase ratio must be defined in terms of the solute-accessible area if transfer occurs by adsorption.⁴²

The equilibrium constant, K , can be expressed as a difference in standard-state chemical potentials, $\mu^\circ(S)$, for the solute, S

$$\ln K = -\left(\frac{\mu^\circ_{\text{sta}}(S) - \mu^\circ_{\text{mobile}}(S)}{RT}\right) = \frac{-\Delta\mu^\circ}{RT} \quad (1)$$

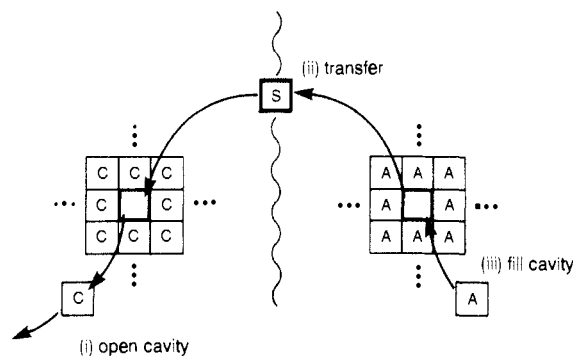

Figure 3. Mechanics of molecule exchange in transfer processes such as partitioning or adsorption. The transfer of solute molecule S requires the opening of a cavity in solvent C and the closing of a cavity in solvent A.

where RT is the gas constant multiplied by absolute temperature.

1. Partitioning

Our aim here is to consider how the standard-state chemical potentials may be predicted from the molecular structures of solutes and solvents and external thermodynamic variables. We focus principally on small solutes, and hence we do not address here the mechanism of retention of polymers or proteins. To do so, we consider first the simplest possible model. If the transfer process is dominated by partitioning, rather than adsorption, then the simplest model of retention is based on the premise that the stationary phase is an amorphous bulk fluid medium and that retention resembles ordinary bulk-phase partitioning, typically characterized by oil/water partition coefficients, for example. In this case, the principal driving force for the transfer of solute is its relative chemical affinity for mobile- and stationary-phase molecules. Many features of retention are well predicted by this simple model.

For this bulk-phase partitioning process, the molecular details of the solute transfer involve (i) the creation of a solute-sized cavity in the stationary phase, (ii) the transfer process, and (iii) the closing of a solute-sized cavity in the mobile phase (see Figure 3). Each of these steps can be described in terms of pair interactions of molecules. For a pair of spherical molecules in the gas phase, the attractive and repulsive components of the interaction potential are generally characterized by a power-law dependence, $u(r) = cr^{-p}$ where c is a constant, negative for attractions and positive for repulsions, and p is a relatively small positive integer. In condensed media such as the mobile and stationary phases, neighboring spherical molecules will have an average equilibrium separation, r^* , shown in Figure 4. Hence the reversible work required to bring the molecules X and Y together from infinite separation is

$$u(r^*) - u(\infty) = u(r^*) = w_{XY} \quad (2)$$

Note that $w_{XY} < 0$. Using the simple lattice model for liquids, wherein every molecule is taken to be surrounded by z nearest-neighboring molecules, the transfer process involves the formation of z bonds of type SC and the breaking of z bonds of type SA (see Figure 3). In addition, the opening of a cavity in solvent C is associated with a chemical potential $-(z/2)w_{CC}$, and the closing of a cavity in solvent A is associated with

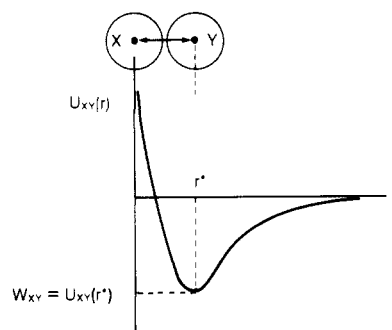

Figure 4. Pair interaction potential, $u_{XY}(r)$, for two simple molecules. Reversible work for bringing molecules X and Y together to their equilibrium separation r^* is w_{XY} .

a chemical potential $(z/2)w_{AA}$.⁴² Hence the complete solute-transfer process is described by

$$\frac{\Delta\mu^\circ}{RT} = \frac{z}{RT} \left(w_{SC} - w_{SA} + \frac{w_{AA}}{2} - \frac{w_{CC}}{2} \right) = \chi_{SC} - \chi_{SA} \quad (3)$$

which is conveniently expressed in terms of the binary solution interaction parameter χ_{XY}

$$\chi_{XY} = \frac{z}{RT} \left(w_{XY} - \frac{w_{XX} + w_{YY}}{2} \right) \quad (4)$$

If the solute or solvent molecules are of a size different from that represented by a single lattice site, then the concentration variable is more appropriately taken to be the volume fraction, and Flory-Huggins correction terms are applicable.⁴³ In particular, if the solute molecule occupies n sites, rather than just one, then the free energy scales with n , since the transfer and cavity interactions depend on $(z-2)n$ (neglecting end effects); i.e.

$$\frac{\Delta\mu^\circ}{RT} = n(\chi_{SC} - \chi_{SA}) \quad (5)$$

where $(z-2)$ now replaces z in eq 4.

The driving forces for solute transfer arise from the nature of the pair interactions, w_{XY} , among neighboring solute and solvent molecules. Different atomic forces contribute to w_{XY} , the reversible work for formation of these attractive noncovalent interactions. If molecules X and Y have net charge, then w has a coulombic interaction energy component. If molecules X and Y contain permanent dipoles, then w has an energetic component proportional to the product of dipole moments. If X and Y have inducible dipoles, then w has an energetic component proportional to the product of the polarizabilities. If some relative orientation of X and Y is involved as they are brought into contact, as with water, wherein hydrogen bonds cause a preferred relative orientation, then w includes both energetic and entropic contributions.

The terms "hydrophobic" and "solvophobic" are widely used to describe the driving force for retention, but there are limited data with which the validity of such description can yet be assessed. The principal diagnostic for this driving force is a particular temperature dependence, namely whereby solute transfer from water is accompanied by a large negative change in heat capacity, being entropy-driven around room

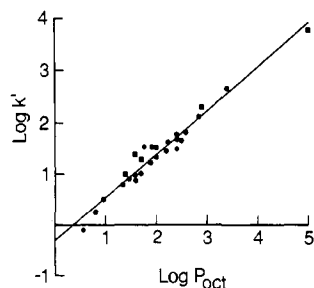

Figure 5. Retention factor k' is proportional to the oil/water coefficient, P ;⁶⁰⁻⁶⁴ data shown are taken from ref 65.

temperature and being enthalpy-driven at higher temperatures. Since some nonpolar solutes do not exhibit this temperature dependence for chromatographic retention,⁴⁴⁻⁴⁹ it should not be assumed that all nonpolar solutes are driven by hydrophobic forces. This will also depend on the nature of the mobile phase. Moreover, insofar as "hydrophobic" interactions have some enthalpic contributions at all but 25 °C, they cannot be considered readily separable from hydrogen-bonding or van der Waals interactions.⁵⁰

For simple molecules, such as hydrocarbons and inert gases, for which the dominant interaction is due to induced dipoles, the Hildebrand solubility parameter concept⁵¹ has been used to provide an additional simplification to this model for retention.⁵²⁻⁵⁷ In these cases, the binary interaction parameter is approximated as a product of factors involving unitary interaction constants, δ_X and δ_Y , the solubility parameters

$$\chi_{XY} = \text{constant} \times (\delta_X - \delta_Y)^2 \quad (6)$$

Although it is convenient, this factorization into unitary constants is often a poor approximation, particularly if forces other than dispersion interactions are involved. A principal weakness arises in representing the XY pair interaction as if it were the geometric mean of XX and YY interactions. The binary parameter provides a better treatment of the pair interactions, but it too is only an approximation. The use of binary interaction parameters is limited by the validity of the assumption that the components are randomly mixed and the assumption of additivity of free energies of transfer.

It is not possible in general to determine what molecular forces dominate a given solute-transfer process simply from a single measurement of the equilibrium constant. For example, to determine the importance of electrostatic interactions, it is necessary to measure the equilibrium constant as a function of pH or salt concentration. To determine whether changes in entropy are involved, as for hydrophobic interactions at room temperature, it is necessary to measure the equilibrium constant as a function of temperature. Some attempts have been made to find simple empirical correlations between solute retention and certain molecular parameters such as hydrophobic substituent constants, van der Waals volumes, molecular connectivity, and molecular surface areas,^{58,59} but such correlations are useful only if the parameters are independent of each other. For example, volume, area, and hydrophobicity are closely related and do not provide a suitable basis set for empirical correlation.

The bulk-phase partitioning model predicts several important features of retention. First, retention should be proportional to the (oil)/(mobile phase aqueous so-

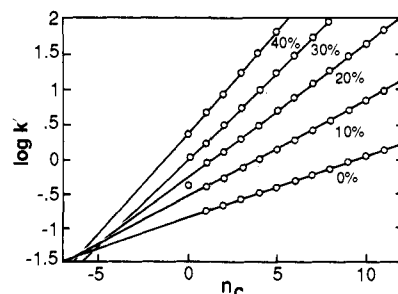

Figure 6. Retention factor k' vs solute size for a homologous series of alkylbenzenes.⁶⁶ The different curves are for different mobile phases of acetonitrile/water (percent water is indicated). If each unit in the homologous series is defined as a "tail" segment and the molecular component that is common to all in the homologous series is the "head", then the slope of this curve gives the free energy of transfer of each tail segment, and the intercept is the ratio of the free energies of transfer of "head" and "tail" segments.⁴²

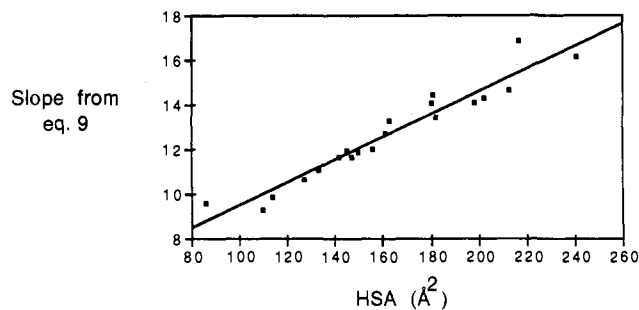

Figure 7. Slopes of plots from eq 9 vs hydrocarbonaceous surface area (HSA) of solutes, verifying the linear dependence on n . Sepralyte C₁₈ column, acetonitrile/water mobile phases.

lution) partition coefficient; this has been widely observed (for recent work, see ref 60-64); see Figure 5 (data taken from ref 65). Second, the retention coefficient depends approximately linearly on the size of the solute molecule, as does the partition coefficient, since the cavities scale with solute size. This dependence is also widely observed,^{2,60,66-69} examples are shown in Figures 6 and 7. Third, because the surface tension of a pure mobile phase, γ_A , is given by

$$\gamma_A \approx w_{AA}/2a \quad (7)$$

where a is the area per AA contact, then under conditions for which other factors are smaller in eq 3, $\ln K$ should scale linearly with the surface tension of the mobile-phase solvent. Experimental evidence supports this relationship^{2,69,70} in those cases. Fourth, factors that change the solubilities (i.e., the χ 's) should affect retention in the same way. For example, added salt reduces the solubilities of hydrocarbons in water⁷¹ and leads to increased partitioning of the solute into the stationary phase.² Similarly, increasing the pH for acidic solutes increases their net charge and decreases their affinities for the stationary phase.²

A most important aspect of real chromatographic retention processes is that the mobile phase is not generally a single-component solvent; typical mobile-phase solvents are mixtures of an aqueous solution with organic modifier such as methanol or acetonitrile. In the bulk-phase partitioning model, retention is described as a process of transfer between bulk media of solute S from a single-component mobile phase A. This model can be readily generalized to account for mobile-phase mixtures of components A and B, with relative concentrations ϕ_A and ϕ_B , respectively. Provided

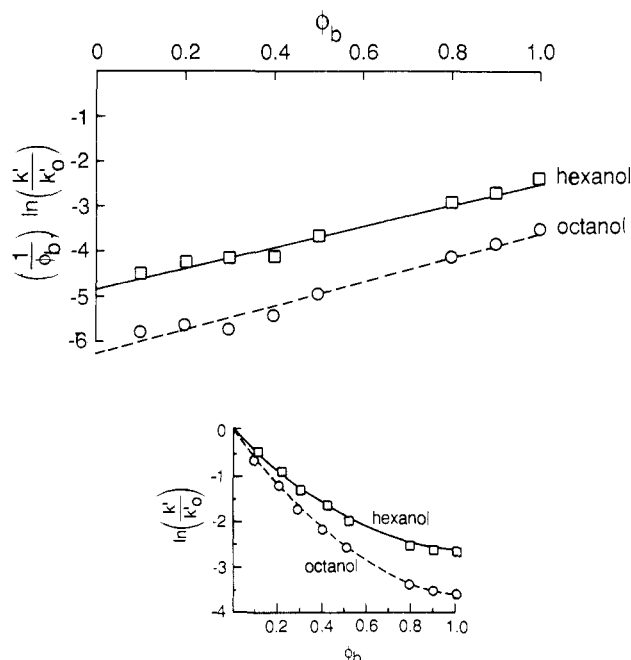

Figure 8. Top: Plot of the type described in eq 9, which linearizes retention vs mobile-phase composition.⁴² Bottom: The standard composition plot for the same situation for solutes hexanol and octanol in acetonitrile/water mixtures.⁷²

A and B are randomly dispersed, the equilibrium constant is⁴²

$$n^{-1} \ln K = (\chi_{SA} - \chi_{SC}) + \phi_B(\chi_{SB} - \chi_{SA} - \chi_{AB}) + \phi_B^2 \chi_{AB} \quad (8)$$

where C represents the stationary phase. This can readily be further generalized to account for any number of solvent components.

It has been suggested⁴² that this quadratic dependence of ϕ_B can be expressed in a more convenient form for the purpose of plotting the dependence of retention on mobile-phase composition. In particular, since $k'/k'_0 = K/K_0$, where the subscript zero indicates the mobile-phase reference state $\phi_B = 0$, eq 8 can be rewritten as

$$\left(\frac{1}{\phi_B}\right) \ln \left(\frac{k'}{k'_0}\right) = n[(\chi_{SB} - \chi_{SA} - \chi_{AB}) + \phi_B \chi_{AB}] \quad (9)$$

which is a linear function of ϕ_B . Hence a plot of $(1/\phi_B) \ln(k'/k'_0)$ vs ϕ_B should be linear in the mobile-phase composition, ϕ_B , provided that the random-mixing approximation holds. The slope and intercepts then provide measures of the binary interaction parameters. Figure 8 shows an example of this type of plot for hexanol and octanol as solutes in acetonitrile/water mobile phases (data taken from ref 72).

This prediction for composition dependence has been recently tested against an extensive data base comprised of nearly 350 sets of experiments of retention of various solutes on various reversed-phase columns as a function of mobile-phase composition.⁶⁸ It is observed that this type of plot is quite useful for a wide range of systems and that the few binary interaction parameters so far obtained in this manner generally agree with those obtained by independent methods. Moreover, Ying et al.⁶⁸ have observed the dependence on cavity size predicted by eq 9; see Figure 7. In addition, it is found that ET-30, a spectroscopic probe, gives a direct measure of

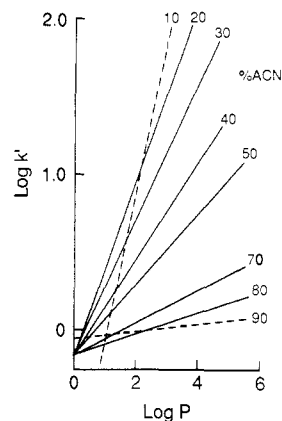

Figure 9. Retention factor k' vs p , the oil/water partition coefficient, as a function of mobile-phase composition. Increasing organic modifier reduces the driving force for retention for a given solute. This dependence is predicted by eq 8;⁴² see text.

these binary interaction free energies. The principal limitation of this plot is that it will fail if the random-mixing approximation fails, which is most suspect in the extremes of concentration, i.e., when one solvent component is in very low concentration.⁵⁴

Figure 9 shows a plot similar to that of Figure 5 of $\ln k'$ vs $\ln P$, where P is the oil/water partition coefficient. However, Figure 9 shows a series of different mobile-phase compositions. It is observed that increased organic modifier in the mobile phase leads to decreased slopes on this plot. This dependence of the slope on mobile-phase composition is predicted by the bulk-phase partitioning model, eq 8.⁴² In eq 8, the quantity $(\chi_{SA} - \chi_{SC})$ is equal to $\ln P$; hence the slope in Figure 9 depends on ϕ_B through the linear and quadratic terms in eq 8. When $\phi_B = 0$, $\ln k'$ should be linear in $\ln P$ with a slope of one; this is the case shown in Figure 5 and the limiting case (for 0% ACN), not shown, in Figure 9.

It follows from eq 8 and 9 that selectivities, for example of CH_2 groups in homologous series of solutes, should decrease with increasing ϕ_B (see discussion around eq 18 of ref 42). This is generally observed.^{42,73,74}

For the properties discussed above, it is clear that bulk-phase partitioning is a good model for retention. Other models are described briefly below. In the following sections, we summarize important refinements involving molecular organization in the stationary phase which can cause substantial deviations from bulk-like partitioning.

2. Solvophobic Theory

One popular model of retention has been the "solvophobic theory", which relates retention to the surface tension of the mobile-phase solvents.^{2,69} As important as the solvophobic theory has been to the development of modern LC, it is based on an incorrect model of the relevant solution processes.⁴² It supposes that retention can be modeled in terms of the association of two solute molecules in a single solvent rather than on the transfer of a solute from one solvent to another. Hence the solvophobic theory does not take cognizance of the interactions of the solute with the second "solvent", the cavity in the stationary phase; it takes into account only the cavity in the mobile phase. The prediction of the solvophobic theory that retention

is independent of the nature of the stationary phase is not in agreement with experiment⁷⁵⁻⁸¹ (see below).

3. Adsorption

An alternative view has held that solute transfer is not a process of partitioning into the stationary phase but involves instead adsorption of the solute to the hydrocarbon surface of the stationary phase. The condition for chemical equilibrium of a solute *S* at infinite dilution exchanging between dilute solution in solvent *A* and adsorption onto the stationary phase is

$$\mu_{\text{adsorbed}}(S) - \mu_{\text{mobile}}(S) = \mu_{\text{adsorbed}}(A) - \mu_{\text{mobile}}(A) \quad (10)$$

Using the same lattice methods as above, one can readily show that the equilibrium constant for adsorption is given in terms of the pair interaction free energies as⁴²

$$\ln K = \frac{w_{SA} + w_{AC} - w_{AA} - w_{SC}}{RT} = \frac{1}{z}(\chi_{AC} - \chi_{SC} + \chi_{SA}) \quad (11)$$

A principal conclusion is that for a given chemical nature of the solute and solvents, w or χ fixed, the driving force for adsorption will be much weaker than the driving force for partitioning (the transfer free energy will be reduced by a factor $1/z = 1/6$ for the simple cubic lattice model). The reason the driving force for adsorption is smaller than for partitioning is that only a fraction $1/z$ of the surface area of the solute exchanges its environment upon adsorption. Comparison of partitioning and adsorption models for retention will be made below.

IV. Effects of the Interphase Chain Organization

The retention model described above is based on the simplifying premise that the stationary phase is a simple amorphous bulk phase of matter. However, the chains of the stationary phase cannot be completely bulk-like since they are constrained by the interface. Chains in the bulk state are defined as those that have the freedom to explore all possible conformations. But when chains are grafted to an interface, there are two constraints that prevent access to all possible conformations.⁸² The first is the boundary condition imposed by the interface; certain configurations are prohibited by the requirement that the chain cannot penetrate the solid interface to which it is grafted. The second constraint, which applies only at sufficiently high surface densities of the grafted chains, arises from lateral interactions among neighboring chains. Both constraints cause interfacially grafted chains to be more "ordered" than bulk chains. In the present context, ordering refers to the partial alignment of the chains normal to the interface. Such interfacially constrained systems of chains have been referred to as "interphases".⁸²⁻⁸⁵

Although these constraints impose a degree of order, that does not imply that the grafted alkyl chains are "rodlike" in nature, as envisioned in early simplified views of the chain organization, shown in Figure 10. The energy differences among the rotational isomers of the methylene bonds of alkyl chains are relatively small at room temperature; hence grafted chains should have access to many rotational conformational states, as indicated schematically in Figure 11. The FTIR

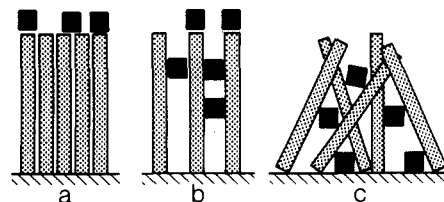

Figure 10. Conventional models of molecular organization of stationary-phase chains in RPLC: (a) "picket fence"; (b) "fur"; (c) "stack".

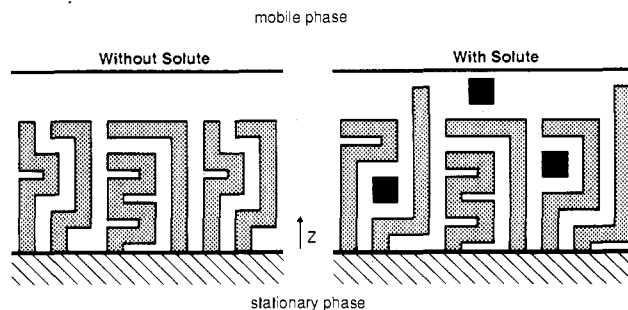

Figure 11. Interphase model of molecular organization of the stationary-phase chains at high density. Partitioning of solute induces chain ordering.

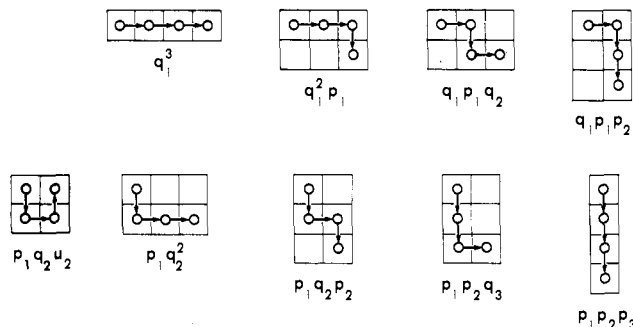

Figure 12. Statistical weights for all the conformations of a four-segment chain.

experiments of Sander et al.⁸⁶ show that grafted alkyl chains have significant populations of gauche bonds.

In this section, we consider how the partial chain ordering in the interphase affects solute retention. We first consider the molecular organization of grafted chains at high surface densities in the absence of retained solute or solvent. Properties of interfacial systems vary with distance normal to the interface, reaching their bulk value at some distance from the interface. The nature of this variation depends on the surface density and length of the chains and on the specific property of interest; this is summarized briefly below and in more detail elsewhere.⁸² The interfacial nature of the chain organization can be represented through use of a lattice of sites, arranged in layers parallel to the interface, numbered from the silica surface $l = 1, 2, 3, \dots, L$. Properties within each layer are assumed to be homogeneous, but they may vary from one layer to the next. The relative probabilities, P_c , of different chain configurations, c , are represented by statistical weights that are products of bond factors p_l , q_l , and u_l for forward steps (from layer l to $l + 1$), side steps (within layer l), and reverse steps (from layer l to $l - 1$), respectively (see Figure 12)

$$P_c = (g_c/Z) \prod_{l=1}^L p_l^{v^+} q_l^{v^0} u_l^{v^-} \quad (12)$$

where $\nu^+_{l,c}$, $\nu^0_{l,c}$, and $\nu^-_{l,c}$ are the number of chain steps in forward, side, and reverse directions, respectively, in layer l in conformation c and $g_c = \prod_{l=1}^L (z-2)^{\nu^0_{l,c}}$ is the degeneracy of configuration c . The partition function, Z , is the sum of the probabilities of all the possible chain configurations. This can be most conveniently represented by a matrix expression

$$Z = 1 = \sum_c P_c = [1 \ 0 \ 0 \dots 0] \mathbf{G}^{n-1} \begin{bmatrix} 1 \\ 1 \\ \vdots \\ 1 \\ 1 \end{bmatrix} \quad (13)$$

where

$$\mathbf{G} = \begin{bmatrix} (z-2)q_1 & p_1 & 0 & 0 & 0 & 0 & \dots & 0 \\ u_2 & (z-2)q_2 & p_2 & 0 & 0 & 0 & \dots & 0 \\ 0 & u_3 & (z-2)q_3 & p_3 & 0 & 0 & \dots & 0 \\ \vdots & \vdots & \vdots & \vdots & \vdots & \vdots & \ddots & \vdots \\ 0 & 0 & \dots & \dots & \dots & \dots & u_L & (z-2)q_L \end{bmatrix} \quad (14)$$

In terms of this partition function, the number of forward steps per chain from layer l averaged over all the conformations is

$$\langle \nu^+_{l,c} \rangle = \frac{\partial \ln Z}{\partial \ln p_l} \quad (15)$$

which is a sum of terms of matrix derivatives, evaluated through use of eq 13. Likewise, the average numbers of side and reverse steps per chain from layer l are

$$\langle \nu^0_{l,c} \rangle = \frac{\partial \ln Z}{\partial \ln q_l} \quad (16a)$$

and

$$\langle \nu^-_{l,c} \rangle = \frac{\partial \ln Z}{\partial \ln u_l} \quad (16b)$$

respectively. For the pure interphase, the constraint on the system is that each layer is filled on average by all chain segments that step forward from layer $l-1$, step sideways in layer l , or are reverse steps from layer $l+1$. That is, the constraint condition is

$$\langle \nu^+_{l-1} \rangle + \langle \nu^0_{l,c} \rangle + \langle \nu^-_{l+1} \rangle = \sigma_l \quad (17)$$

where σ_l is the number of chains divided by the area in layer l .

The condition of conformational equilibrium is that the entropy of the system, S_c , be a maximum subject to the imposed constraints. The conformational entropy of the N chains can be expressed in terms of the probabilities of the chain conformations:^{82,85}

$$\frac{S_c}{Nk} = -\sum_c P_c \ln \left(\frac{P_c}{g_c} \right) \quad (18)$$

Maximization of the entropy then leads to the result that

$$p_{l-1} = q_l = u_{l+1} \quad (19)$$

for all layers l .

When these values are substituted into the matrix in eq 14 and when that matrix is substituted in turn into eq 13, 15, 16, and 17, then there are L equations in L

unknowns. These equations can be solved by standard numerical methods to give values for p_l , q_l , and u_l for $l = 1, 2, 3, \dots, L$ as a function of the length and surface density of the interphase chains; for details, see ref 82 and 85. For the pure interphase of grafted chains that fully fill the volume available to them, without solute or solvent, this approach leads to the prediction of the conformational properties of the chains subject to (i) the boundary condition that the chains cannot penetrate the surface and (ii) the packing constraint that steric overlap among neighboring molecules is prohibited. Above surface densities of approximately one-third of the maximum value, steric constraints among neighboring chains become severe ($2.7 \mu\text{mol}/\text{m}^2$ for alkyl chains since the maximum lateral packing density is $8.1 \mu\text{mol}/\text{m}^2$ in alkane crystals).

There are two principal predictions for the conformations of the grafted chains in the absence of penetrant solute or solvent molecules. First, for surface densities that are above this threshold at which neighbor interactions become important, the theory predicts a "disorder gradient", wherein the chain segments nearest the surface are the most highly ordered (i.e., aligned normal to the surface), with rapidly increasing disorder toward the chain ends. These equilibrium gradients have been widely observed in bilayer membranes,⁸⁷ which are comprised of surfactant chains subject to similar interfacial constraints. Motional gradients have been observed in RPLC stationary phases.⁸⁸⁻⁹⁰ Second, increasing the surface density of the chains should lead to increased chain ordering, i.e., larger numbers of forward bonds and smaller numbers of lateral bonds.

Now we consider the process of solute partitioning into the stationary phase. The condition for solute-transfer equilibrium is that the chemical potentials are equal for solute in the mobile and stationary phases

$$\mu_{\text{sta}}(\text{S}) = \mu_{\text{mobile}}(\text{S}) \quad (20)$$

With the standard thermodynamic approximations (i) that for solute at infinite dilution, the reference state is chosen so that the activity coefficient equals one, and (ii) that solute and mobile-phase molecules have no change in internal degrees of freedom and are spherical and of equal size, the mole fraction ϕ is an appropriate concentration variable, and the chemical potential is

$$\mu_{\text{mobile}}(\text{S}) = \mu^\circ_{\text{mobile}}(\text{S}) + RT \ln \phi \quad (21)$$

For the solute in the mobile phase, the $RT \ln \phi$ term derives from the translational entropy of mixing, and the standard-state chemical potential, $\mu^\circ(\text{S})$, arises from the neighbor contact interactions described in the previous sections. In the stationary phase, on the other hand, the chemical potential of the solute is determined by these factors, and one other. The insertion of solute into a partially ordered chain phase of fixed surface density leads to further extension and ordering of the interphase chains. Hence solute insertion is entropically unfavorable. It can be shown⁸⁵ that this entropic tendency of the chains to oppose solute transfer into the stationary phase results in the appearance of the statistical weight q_l (see eq 12 and 19, for example) in the chemical potential

$$\mu_{\text{sta},l}(\text{S}) = \mu^\circ_{\text{sta},l}(\text{S}) + RT \ln \left(\frac{\phi_l}{q_l} \right) \quad (22)$$

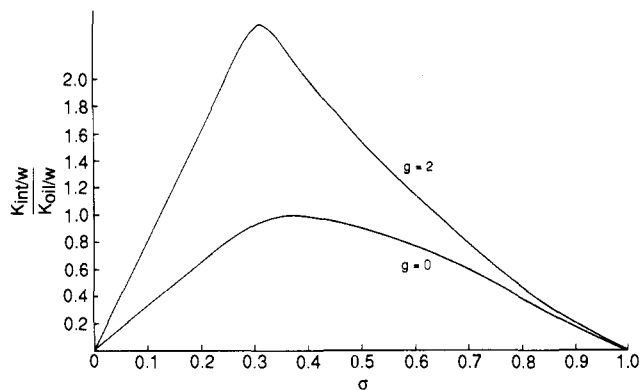

Figure 13. Predictions of the interphase theory⁸² for partition coefficient vs surface density for two different solutes (g is the interfacial free energy of the solute⁸⁵). At low densities, partitioning is proportional to hydrocarbon coverage of the surface; at high densities, solute is expelled due to chain ordering caused by lateral packing constraints in the interphase.

This factor $0 \leq q_l \leq 1$ decreases with increasing surface density; it equals one for random polymer configurations and equals zero for chains at the maximum surface density.

There are two principal predictions for the effects of chain ordering on solute retention by the stationary phase. First, it is predicted that solute will preferentially distribute nearer to the chain ends than to the anchored ends of the chains, since the chain order is smallest near the free ends. In similar membrane experiments, this prediction has been confirmed by neutron scattering experiments on deuterated hexane in dioleoyllecithin bilayers.⁹¹ Second, as the surface density approaches its maximum value, $q_l \rightarrow 0$ and $\mu_{sta} \rightarrow \infty$, the solute is predicted to become increasingly expelled from the stationary phase due to the entropic effects of chain ordering. At the maximum surface density, the theory predicts that no solute will partition into the stationary phase.

Figure 13 shows the theoretical prediction for the dependence of partitioning on surface density of the grafted chains.^{82,85,92} At low densities, partitioning should increase linearly with the surface coverage of the grafted chains as the surface becomes more fully covered by hydrocarbons and thus becomes less polar. The partition coefficient should reach a maximum at the point at which neighbor interactions among chains become important. At higher densities, less solute partitions due to increasing entropic expulsion of solute by the grafted chains.

This partitioning dependence on chain density is not directly observable in chromatographic retention, however. Retention is a product of the thermodynamic distribution coefficient times the volume of the stationary phase. While K decreases at higher densities, the stationary-phase volume increases, and the effects approximately cancel. This plateauing of retention with increasing chain density has been previously observed.⁹³⁻⁹⁵

Shown in Figure 14 are the experimental data of Sentell and Dorsey,⁸¹ which confirm the theoretical prediction. Figure 15 shows a similar decrease in partition coefficient of benzene in bilayer membranes of lecithins as a function of the surface density of the chains,⁹⁶ note that only high densities are accessible in the bilayers. A central conclusion from the experiments

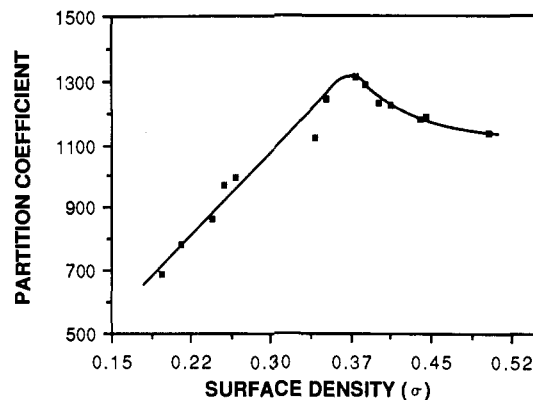

Figure 14. Experiments of Sentell and Dorsey⁸¹ of partition coefficient of *p*-terphenyl from retention measurements vs normalized surface density ($\sigma = 1$ corresponds to $8.1 \mu\text{mol}/\text{m}^2$).

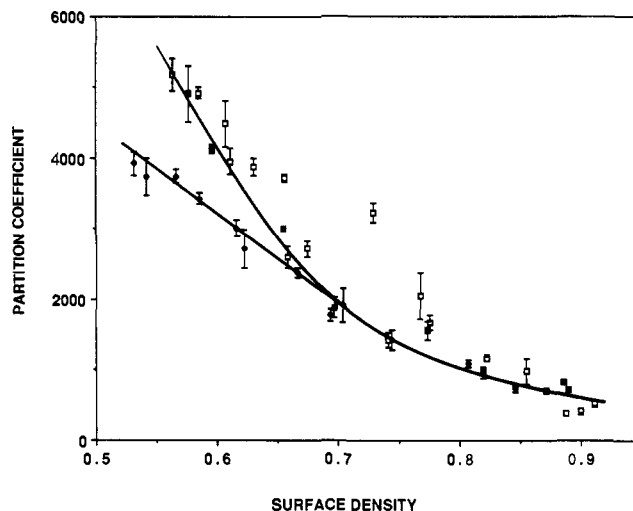

Figure 15. Experiments of De Young and Dill⁹⁶ on partition coefficient of benzene into bilayer membranes of lecithins (phosphatidylcholines) vs normalized surface density. These experiments cover higher surface densities than are common in RPLC. (\blacklozenge) Dilauryl-PC; (\square) dimyristoyl-PC; (\blacksquare) dipalmitoyl-PC. Surface density is varied by temperature or incorporation of cholesterol and is measured by ^2H NMR.

of Sentell and Dorsey is that the chain organization of the stationary phase plays a major role in retention. Variation in the surface density of the grafted chains can cause change in retention over the full range of solute transfer from a minimum of zero retention to a maximum dictated by the bulk-phase partitioning driving force. These results are in strong conflict with predictions of the solvophobic theory,^{2,69} according to which retention should not depend on the nature of the stationary phase. Other experiments have previously suggested the importance of the stationary phase.⁷⁵⁻⁷⁹ Some of the earlier experiments, however, have been difficult to interpret due to associated changes in the phase ratio. A second principal conclusion from the comparison of the data of Sentell and Dorsey with predictions of the interphase theory is that partitioning, rather than adsorption, is a dominant mechanism of retention; also see below.

Thus the partitioning of solutes into the interphase is driven by two forces. One force arises from the chain organization imposed by the interfacial constraints, and the other from the chemistry of the neighbor interactions of solute molecules. The partial ordering of the stationary-phase chains at high densities leads to an

unfavorable entropy of mixing of solute and leads to a gradient of solute distribution. The second driving force is the chemistry of neighbor interactions, just as in the bulk-phase partitioning model, described in terms of the standard-state chemical potentials or, equivalently, by the binary interaction parameters (see eq 3-5, for example). Hence the predictions of the interphase model circumscribe those described above for the bulk-phase model, some examples of which are shown in Figures 5-9. However, it is also clear that certain properties of the interphase will differ significantly from those of bulk phases. A principal prediction is that the nature of the stationary phase will depend strongly on the surface density of the chains, a variable that has often been neglected in reporting experimental data.

The first statistical mechanical model to make an important contribution in addressing the effects of chain organization of the stationary phase was that of Martire and Boehm.⁹⁷ That model is based on the simplifying assumption that the stationary phase has liquid crystalline, rather than interfacial, organization. In that case, the anisotropy of the chain segments is approximately taken into account, but not its variation with distance from the interface; chain configurations are assumed to be uniformly distributed with distance from the interface throughout the stationary phase. In the model of Martire and Boehm, the free energy is comprised of three terms: (i) the contact free energies, taken into account in the same manner as described above for the bulk-phase and interphase models, (ii) a configurational free energy of the chains and solutes, and (iii) an anisotropic packing entropy. To evaluate the configurational free energy contribution, they model each chain as a string of units, each of which may be oriented independently along the x , y , or z direction. This approximation, however, does not prevent backtracking of one chain segment upon its predecessor, for example when a $+x$ step is followed by a $-x$ step. Better approximation requires the use of conditional probabilities for the chain segments, as is done in the interphase model described above. A second result of the assumption of monomer independence is an inexact enumeration of Boltzmann factors to account for the bending energies of the chains. As an approximation to count the number of chain bends, they count instead the number of bonds parallel to the interface, within the x - y plane. This approximation errs when two bonds are collinear in the x - y plane; in that case, the Martire and Boehm model counts two bends, whereas in fact there are none. Better approximation requires conditional probabilities, of the type readily taken into account in the interphase matrix method described above. Finally, the packing entropy (iii) in the Martire and Boehm model resembles that of the interphase theory in the limit of long chain lengths or for segments nearest the graft surface, but it neglects the variation of constraint with distance from the interface. For the short chains of relevance to chromatography, their model will substantially overestimate the ordering of the chains.

V. Experimental Tests of the Molecular Organization of Stationary Phases

Few experimental tests yet exist that show the full details of the molecular conformations of the grafted

chains of stationary phases. At low surface densities, where interactions among neighboring chains are small, there should be significant conformational disorder of the grafted chains. This is supported by FTIR measurements of band intensities attributable to gauche bonds⁹⁶ and by ²H NMR quadrupolar-splitting experiments on selectively deuterated alkylsilane chains that indicate chain ordering only slightly greater than isotropic.⁹⁸ Most commercially available monomeric stationary phases are below this critical surface density.

Since the grafted molecules are largely unconstrained by neighboring chains at these low densities, the molecular organization will be much simpler than that in interphases, and retention should principally be governed only by the total coverage of the surface by alkyl molecules. Hence, as noted above, this leads to the prediction of a linear increase in k' vs surface coverage at low surface densities, shown in Figure 13, which is confirmed by the experiments shown in Figure 14. On this basis, only the mean value of surface coverage is relevant in specifying the amount of retention; no higher moments, such as the variance (i.e., the degree of "clustering"), of the spatial distribution function should affect k' . Nevertheless, even though k' will be independent of the degree of "patchiness", the question of surface variations in density is of much interest in itself for understanding molecular organization in these systems. At very low densities (0.1-1.1 $\mu\text{mol}/\text{m}^2$), Lochmüller et al.^{99,100} have performed experiments that they have interpreted as implying that there is much lateral clustering of the grafted chains. Using 3PPS [(3-(3-pyrenyl)propyl)dimethylchlorosilane], a molecule comprised of a pyrene ring attached through a short propyl chain to the silane functionality, they have fit luminescence decay kinetics data to a three-exponential function and monitored populations that do or do not form excimers. They observe a high concentration (70%) of molecules that are closer than the average spacing calculated from the known surface density. However, since fluorescence transfer is most efficient among closer molecules, it would have been more appropriate to account for closest pairwise spacings, rather than average pairwise spacings, and this statistical correction alone may account for their observations, rather than any real effect of clustering. Moreover, it is not clear that these experiments have implications for chromatographic conditions. Pyrene has an inherent tendency to cluster; these molecules are strongly self-associating due to π -bond overlap, as is evidenced from their extremely high melting and boiling temperatures.¹⁰¹ On the other hand, alkyl grafted chains should have much less tendency to cluster than these pyrene probes, since their association will be opposed by a strong configurational entropic repulsion, prohibiting high surface densities. This entropic repulsion is evidenced by the difficulty in devising synthesis procedures for achieving high-density bonded phases (see section II).

Although the most common monomeric phases are of low density, phases of higher density are desirable for reasons outlined in section II. At sufficiently high densities (above 2.7 $\mu\text{mol}/\text{m}^2$), packing constraints among neighboring chain molecules should introduce ordering, an average degree of alignment normal to the graft plane. This orientational anisotropy has been

widely measured by ^2H NMR in bilayer membranes and micelles,⁸⁷ which are interphases subject to similar constraints. In addition, this anisotropy has been observed by Kelusky and Fyfe in grafted systems of lower densities in the presence of excess hexane, which presumably penetrates and induces ordering of the grafted chains.⁹⁸

In principle the dependence of retention on temperature should give additional information on the molecular mechanism of solute uptake. The temperature dependence can be described by use of the thermodynamic relation

$$-RT \ln K = \Delta G^\circ = \Delta H^\circ - T\Delta S^\circ \quad (23)$$

Hence

$$\ln k' = \ln K\Phi = \frac{-\Delta H^\circ}{RT} + \frac{\Delta S^\circ}{R} + \ln \Phi \quad (24)$$

Experiments show that the retention of most solutes decreases with increasing temperature and that $\ln k'$ increases approximately linearly with $1/T$.⁴⁴⁻⁴⁹ Thus ΔH° is negative for the process of transfer of most solutes from the mobile phase to the stationary phase and appears to be essentially independent of temperature over the narrow temperature ranges that have been experimentally accessible. Retention also generally decreases with temperature. The enthalpies measured in these studies are relatively large, in the range of a few kcal/mol. Too little information is yet available to determine whether "hydrophobic" driving forces are important for retention. It has ordinarily not been possible to obtain reliable estimates for the magnitude of the entropic forces, ΔS° , relative to these enthalpic contributions, since the constant in eq 24 is the sum of $\Delta S^\circ/R$ and a constant dependent upon the phase ratio, $\ln \Phi$, which is often not accurately known. Entropic forces can include the partial chain ordering in high-density interphases, which will tend to reduce $\ln k'$, and the ordering of water around nonpolar solutes in the mobile phase at 25 °C, which will tend to increase $\ln k'$. Nevertheless, the observation that the enthalpies are large, negative, and temperature-independent is suggestive that the chemical driving forces for retention may be better modeled by the simpler solution theories⁵¹ than by invoking the "hydrophobic" ordering of water, at least in the common mobile-phase mixtures.

Phase transitions have been observed in grafted phases as a function of temperature or solvent.^{47,102-108} The thermal transition has been observed to be of second order,^{103,107} becoming sharper with increased chain length and surface density and with transition temperatures that increase with chain length.^{47,103,105} The transitions in these grafted phases are not identical with those of simpler alkanes. Insofar as they do not show an even/odd effect,¹⁰² they appear to bear more resemblance to the melt/rotator phase transition of normal alkanes than to the rotator phase/crystal transition. However, insofar as their enthalpies of transition are small (41.8 J/g), about one-fourth that of the melt/rotator phase transition,^{102,107} they bear closer resemblance to the rotator/crystal transition than to that of the melt/rotator transition. Entropies of transition are also smaller than for the melt/rotator phase transition in alkanes. The presence of solutes can sig-

nificantly affect these transitions; for example, polar solvents have been observed to raise the transition temperatures.¹⁰⁶ Although the balance of forces driving these transitions is not yet understood, it is not surprising that they should differ from their alkane counterparts, since the anchoring of one end of each chain leads to freezing a lateral and perpendicular degree of freedom.

The statistical mechanical theories of retention^{42,97} predict what has been referred to as "breathing":⁹⁷ the uptake of organic modifier should increase the thickness of the stationary phase. This is a simple consequence of the constancy of the surface density and the volume within the stationary-phase "solution". These predictions are supported by evidence for the uptake of organic modifier and some evidence for conformational changes of the grafted chains upon uptake.^{73,74,89,109-113} It follows that retention time for a nonretained solute should decrease with increasing ϕ_B . Uptake of the organic co-solvent may affect the driving force for retention of solute, but these effects should be relatively small and self-limiting. Consider the situation in which the chemical nature of cosolvent B is systematically varied so as to have increasing affinity for partitioning into the stationary phase. This will lead to greater amounts of B taken up by the stationary phase. However, at the same time that there is more uptake of B, there is also greater chemical similarity of B with the stationary phase. The greater chemical similarity causes smaller and smaller deviation in the driving force for solute partitioning relative to that of the original pure stationary phase.

The prediction of the interphase theory that solute distribution should depend on distance from the anchoring surface is supported by experiments of Burke on bonded phases¹¹⁴ and is in agreement with small-angle neutron scattering experiments of deuterated hexane in similarly constrained dioleoyllecithin bilayers.⁹¹

For some time, one prominent view has been that the mechanism of retention was dominated by adsorption rather than by partitioning. This view derived principally from an important experiment in which Colin and Guiochon showed that the driving force for retention was weaker than the driving force for partitioning of solute into oil,¹¹⁵ see Figure 16. As noted above, one interpretation of this observation is that solute is adsorbed, whereby only part of the surface of a solute molecule changes its environment in the transfer process; hence the free energy of solute transfer would be smaller than for partitioning. It is now clear, however, that, in general, partitioning is the principal mechanism of retention. This follows from three lines of evidence. First, adsorption should not depend on the surface density of the grafted chains, whereas partitioning should. Hence it is clear from the significant dependence of retention on surface density observed by Sentell and Dorsey (Figure 14) and from the close agreement with the partitioning theory (compare Figure 13) that partitioning is the dominant retention mechanism in those cases. Hence the results of Colin and Guiochon are explained by the prediction, shown in Figure 13, that under most circumstances the concentration of solute that partitions should be smaller than predicted by the oil/water partition coefficient. At low

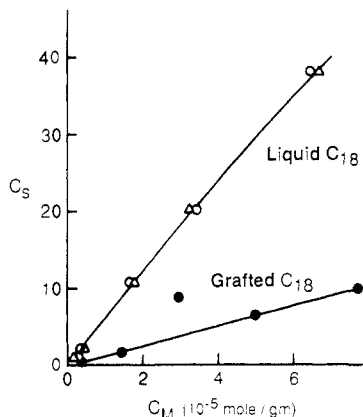

Figure 16. Experiments of Colin and Guiochon¹¹⁵ comparing solute uptake by C_{18} grafted chain stationary phase with solute uptake by amorphous bulk-phase C_{18} liquid chain stationary phase. C_M is the concentration of the solute in the mobile phase, and C_S is the concentration measured in the stationary phase. Solute partitions less into the grafted chains than into the amorphous bulk phase. This is attributed to the surface density of the grafted chains being unequal to the precise value required to mimic bulk-phase partitioning; see text and Figure 13.

surface densities, retention should be diminished due to incomplete coverage of the silica surface by the chains, and at high surface densities partitioning should be diminished because of solute expulsion due to the chain ordering. The second line of evidence that favors the partitioning mechanism comes from measurement of the slope of retention vs oil/water partition coefficients, from which the area of solute exposure can be deduced.⁴² Of course, there are some circumstances in which adsorption must dominate, such as for stationary phases of chains that are either very short or at very high surface densities.^{42,116,117} Third, Tchaplá et al.¹¹⁸ showed a discontinuity in plots of $\log k'$ vs carbon number of a homologous series of solutes, at a point where the carbon number of the homologous series equaled the length of the organic ligand of the stationary phase. This effect was noted with seven different homologous series and stationary-phase chain lengths of C_1 , C_6 , C_8 , C_{14} , and C_{18} . These experiments are further evidence of partitioning of small molecules.

One longstanding puzzle has been why reversed-phase liquid chromatography provides such good separations. Molecules with nearly identical oil/water partition coefficients can often be well separated. An elegant demonstration of this is the experiment of Wise and Sander using a set of 12 polyaromatic hydrocarbon isomers.²⁴ Each molecule has five aromatic rings; they differ only in their molecular configuration. This experiment offers strong evidence that the bulk-phase partitioning model does not provide a fully satisfactory description of retention. Similar evidence in other systems shows that selectivity is partly dependent upon the shapes of the solute molecules.^{119,120} The statistical mechanical theories^{97,121} predict that it is the anisotropy of the grafted chains that gives rise to shape selectivity among solute molecules. In brief, molecules that can most effectively align with the grafted chains, normal to the interface, are those that are most effectively retained. It costs more free energy to insert each solute substructure that lies parallel to the interface than each substructure that aligns with the chains normal to the interface; hence the shape selectivity. In agreement with this prediction, Lochmüller et al. have shown that

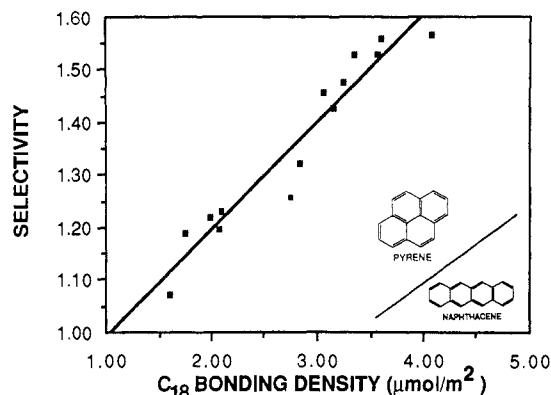

Figure 17. Pyrene/naphthalene selectivity vs octadecyl bonding density at 35.0 °C for acetonitrile/water (85/15) as the mobile phase.

molecules are retained in the order rods > disks > flexible chains.⁷⁷ The selectivity is predicted to increase with increasing surface density of the grafted chains.¹²¹ This may account for the observations that polymeric phases are more selective than monomeric phases^{23,122,123} since their surface densities, although not known unequivocally, may be higher.^{25,124} In a more direct confirmation of the theory, Sentell and Dorsey have observed increasing selectivity with surface density in a homologous series of phenyl compounds.¹²⁵ The selectivity for six four-ring PAHs was also measured over the bonding density range 1.74–4.07 $\mu\text{mol}/\text{m}^2$. The selectivity for every possible pairing of these compounds was determined, and for all but two pairs, a clear correlation between selectivity and bonding density was found. Figure 17 shows the selectivity for two of the compounds vs bonding density with a mobile phase of 85:15 acetonitrile/water.

VI. Conclusions

We have reviewed the theory and the experiments pertinent to the mechanism of molecular retention for small molecules in reversed-phase liquid chromatography, and we have reviewed the synthesis and molecular organization of the stationary phases. Retention is a process of transfer of solute from a mobile-phase environment into a stationary-phase environment and hence depends on the nature of both the mobile and stationary phases. In general, the solute partitions into, rather than adsorbing onto, the stationary phase; that is, it becomes nearly fully embedded within the grafted chains. There should be some preference of hydrophobic solutes to be near the chain ends of high-density phases, however, due to the variation of the configurational constraints with depth. Partitioning is strongly dependent upon the surface density of the grafted chains, increasing with surface coverage of the silica by hydrocarbon, until it reaches a point at which lateral packing constraints among neighboring chains give rise to chain ordering. Beyond that density, further increases in surface density lead to entropic expulsion of solute. The chain anisotropy at these higher densities should also lead to higher solute selectivities. Hence the stationary phase plays a role of fundamental importance in retention and selectivity in reversed-phase liquid chromatography. Much still remains to be done. The understanding of the behavior of large molecules is meager. Temperature effects, the intercalation of

organic modifiers, and secondary retention processes all still remain to be investigated.

With better understanding of the retention process in reversed-phase chromatography will hopefully come other benefits. Stationary-phase reproducibility, longevity, and design for specific separations should improve as well. Improvements in expert systems and development of the long-discussed liquid chromatographic retention index system may also be forthcoming. More wide-reaching advances may be made possible through the ability to study other interphase systems by the use of chromatographic stationary phases. Improvements in measuring physicochemical properties of solutes, modeling of bioavailability, and transport rates are obvious areas of interest.

Acknowledgments. We thank Dr. J. Naghizadeh for helpful discussions. We are grateful for support of this work by NIH GM33382 and for the Pew Scholars program for support of K.A.D.

VII. Literature Cited

- (1) Majors, R. E. *LC-GC Mag.* 1988, 6, 298.
- (2) Melander, W.; Horvath, C. In *High Performance Liquid Chromatography: Advances and Perspectives*; Horvath, C., Ed.; Academic Press: New York, 1980; Vol. 2.
- (3) Howard, G. A.; Martin, A. J. P. *Biochem. J.* 1950, 46, 532.
- (4) Ettre, L. S.; Zlatkis, A., Eds. *75 Years of Chromatography: A Historical Dialogue*; Elsevier: Amsterdam, 1979.
- (5) Laitinen, H. A. *Anal. Chem.* 1973, 45, 2305.
- (6) Unger, K. K. *Porous Silica*; Elsevier: Amsterdam, 1979.
- (7) Sander, L. C.; Wise, S. A. *CRC Crit. Rev. Anal. Chem.* 1987, 18, 299.
- (8) Kohler, J.; Chase, D. B.; Farlee, R. D.; Vega, A. J.; Kirkland, J. J. *J. Chromatogr.* 1986, 352, 275.
- (9) Kohler, J.; Kirkland, J. J. *J. Chromatogr.* 1987, 385, 125.
- (10) Szabo, K.; Le Ha, N.; Schneider, P.; Zeltmer, P.; Kovats, E. sz. *Helv. Chim. Acta* 1984, 67, 2128.
- (11) Buszewski, B.; Nondek, L.; Jurasek, A.; Berek, D. *Chromatographia* 1987, 23, 442.
- (12) Buszewski, B.; Supryniewicz, Z. *Chromatographia* 1987, 24, 573.
- (13) Buszewski, B.; Jurasek, A.; Garaj, J.; Nondek, L.; Novak, I.; Berek, D. *J. Liq. Chromatogr.* 1987, 10, 2325.
- (14) Kinkel, J. N.; Unger, K. K. *J. Chromatogr.* 1984, 316, 193.
- (15) Corriu, R. J. P.; Guerin, C. *J. Organomet. Chem.* 1980, 198, 231.
- (16) Sander, L. C.; Wise, S. A. *J. Chromatogr.* 1984, 316, 163.
- (17) Sands, B. W.; Kim, Y. S.; Bass, J. L. *J. Chromatogr.* 1986, 360, 353.
- (18) Golding, R. D.; Barry, A. J.; Burke, M. F. *J. Chromatogr.* 1987, 384, 105.
- (19) Khong, T. M.; Simpson, C. F. *Chromatographia* 1987, 24, 385.
- (20) Blain, R.; Hartwick, R. A. *HPLC '88, Abstract W-P-323* 1988.
- (21) Sentell, K. B.; Barnes, K. W.; Dorsey, J. G. *J. Chromatogr.* 1988, 455, 95.
- (22) Unger, K. K.; Becker, N.; Roumeliotis, P. *J. Chromatogr.* 1976, 125, 115.
- (23) Sander, L. C.; Wise, S. A. *Anal. Chem.* 1984, 56, 504.
- (24) Wise, S. A.; Sander, L. C. *HRC & CC, J. High Resolut. Chromatogr. Chromatogr. Commun.* 1985, 8, 248.
- (25) Shah, P.; Rogers, L. B.; Fetzer, J. C. *J. Chromatogr.* 1987, 388, 411.
- (26) Fazio, S. D.; Tomellini, S. A.; Shih-Hsien, H.; Crowther, J. B.; Raglione, T. V.; Floyd, T. R.; Hartwick, R. A. *Anal. Chem.* 1985, 57, 1559.
- (27) Lüllmann, C.; Genieser, H.-G.; Jastorff, B. *J. Chromatogr.* 1985, 323, 273.
- (28) Mussche, P.; Verzele, M. *J. Anal. Appl. Pyrol.* 1983, 4, 2773.
- (29) Arles, R. E.; Gutteridge, C. S.; Macrae, R. *J. Chromatogr.* 1985, 319, 285.
- (30) Benson, J. R.; Woo, D. J. *J. Chromatogr. Sci.* 1984, 22, 386.
- (31) Antle, P. E.; Goldberg, A. P.; Snyder, L. R. *J. Chromatogr.* 1985, 321, 1.
- (32) Antle, P. E.; Snyder, L. R. *LC Mag.* 1984, 2, 840.
- (33) Cheng, W.; McCown, M. *J. Chromatogr.* 1985, 318, 173.
- (34) Melander, W. R.; Horvath, C. *Chromatographia* 1982, 15, 86.
- (35) Krstulovic, A. M.; Colin, H.; Tchaplá, A.; Guiochon, G. *Chromatographia* 1983, 17, 228.
- (36) Isaaq, H. J. *J. Liq. Chromatogr.* 1981, 4, 1917.
- (37) Tanaka, N.; Sakagami, K.; Araki, M. *J. Chromatogr.* 1980, 199, 327.
- (38) Sander, L. C.; Wise, S. A. *Anal. Chem.* 1987, 59, 2309.
- (39) Glajch, J. L.; Kirkland, J. J. *Anal. Chem.* 1983, 55, 319A.
- (40) Cooper, W. T.; Lin, L.-Y. *Chromatographia* 1986, 21, 335.
- (41) Snyder, L. R. *J. Chromatogr. Sci.* 1978, 16, 223.
- (42) Dill, K. A. *J. Phys. Chem.* 1987, 91, 1980.
- (43) Flory, P. J. *Principles of Polymer Chemistry*; Cornell University Press: Ithaca, NY, 1953.
- (44) Issaq, H. J.; Fox, S. D.; Lindsey, K.; McConnell, J. H.; Weiss, D. E. *J. Liq. Chromatogr.* 1987, 10, 49.
- (45) Grushka, E.; Colin, H.; Guiochon, G. *J. Chromatogr.* 1982, 248, 325.
- (46) Dufek, P. *J. Chromatogr.* 1984, 299, 109.
- (47) Gilpin, R. K.; Squires, J. A. *J. Chromatogr. Sci.* 1981, 19, 195.
- (48) Chmielowiec, J.; Sawatzky, H. *J. Chromatogr. Sci.* 1979, 17, 245.
- (49) Snyder, L. R. *J. Chromatogr.* 1979, 179, 167.
- (50) Privalov, P.; Gill, S. J. *Adv. Protein Chem.*, in press.
- (51) Hildebrand, J. H.; Scott, R. L. *The Solubility of Nonelectrolytes*; Reinhold: New York, 1950.
- (52) Schoenmakers, P. J.; Billiet, H. A. H.; Tijssen, R.; de Galan, L. *J. Chromatogr.* 1978, 149, 519.
- (53) Schoenmakers, P. J.; Billiet, H. A. H.; de Galan, L. *Chromatographia* 1982, 15, 205.
- (54) Schoenmakers, P. J.; Billiet, H. A. H.; de Galan, L. *J. Chromatogr.* 1983, 282, 107.
- (55) Jandera, P.; Colin, H.; Guiochon, G. *Anal. Chem.* 1982, 54, 435.
- (56) Karger, B. L.; Snyder, L. R.; Eon, C. *Anal. Chem.* 1978, 50, 2126.
- (57) Colin, H.; Guiochon, G.; Jandera, P. *Anal. Chem.* 1983, 55, 442.
- (58) Jinno, K.; Kawasaki, K. *Chromatographia* 1984, 18, 90.
- (59) Jinno, K.; Kawasaki, K. *Chromatographia* 1983, 17, 445.
- (60) Schantz, M. M.; Martire, D. E. *J. Chromatogr.* 1987, 391, 35.
- (61) Opperhuizen, A.; Sinnige, T. L.; van der Steen, J. M. D.; Hutzinger, O. *J. Chromatogr.* 1987, 388, 51.
- (62) Braumann, T. *J. Chromatogr.* 1986, 373, 191.
- (63) Minick, D. J.; Sabatka, J. J.; Brent, D. A. *J. Liq. Chromatogr.* 1987, 10, 2565.
- (64) Kaliszan, R. *CRC Crit. Rev. Anal. Chem.* 1986, 16, 323.
- (65) Butte, W.; Fooker, C.; Klussmann, R.; Schuller, D. *J. Chromatogr.* 1981, 214, 59.
- (66) Colin, H.; Krstulovic, A. M.; Gonnord, M.-F.; Guiochon, G.; Yun, Z.; Jandera, P. *Chromatographia* 1983, 17, 9.
- (67) Mockel, H. J.; Welter, G.; Meltzer, H. *J. Chromatogr.* 1987, 388, 255, 267, 275, 285.
- (68) Ying, P. T.; Dorsey, J. G.; Dill, K. A., submitted.
- (69) Horvath, C.; Melander, W.; Molnar, I. *J. Chromatogr.* 1976, 125, 129.
- (70) Hammers, W. E.; Meurs, G. J.; deLigny, C. L. *J. Chromatogr.* 1982, 246, 169.
- (71) Tanford, C. *The Hydrophobic Effect*, 2nd ed.; Wiley-Interscience: New York, 1980.
- (72) Karger, B. L.; Gant, J. R.; Hartkopf, A.; Weiner, P. H. *J. Chromatogr.* 1976, 128, 65.
- (73) Yonker, C. R.; Zwier, T. A.; Burke, M. F. *J. Chromatogr.* 1982, 241, 257.
- (74) Yonker, C. R.; Zwier, T. A.; Burke, M. F. *J. Chromatogr.* 1982, 241, 269.
- (75) Lochmüller, C. H.; Wilder, D. R. *J. Chromatogr. Sci.* 1979, 17, 574.
- (76) Lochmüller, C. H.; Hangac, H. H.; Wilder, D. R. *J. Chromatogr. Sci.* 1981, 19, 130.
- (77) Lochmüller, C. H.; Hunnicutt, M. L.; Mullaney, J. F. *J. Phys. Chem.* 1985, 89, 5770.
- (78) Sadek, P. C.; Carr, P. W. *J. Chromatogr.* 1984, 288, 25.
- (79) Berendsen, G. E.; Pikaart, K. A.; de Galan, L.; Olieman, C. *Anal. Chem.* 1980, 52, 1990.
- (80) Chretien, J. R.; Walczak, B.; Morin-Allory, L.; Dreux, M.; Lafosse, M. *J. Chromatogr.* 1986, 371, 253.
- (81) Sentell, K. B.; Dorsey, J. G. *Anal. Chem.*, submitted.
- (82) Dill, K. A.; Naghizadeh, J.; Marqusee, J. A. *Annu. Rev. Phys. Chem.* 1988, 39, 425.
- (83) Dill, K. A.; Flory, P. J. *Proc. Natl. Acad. Sci. U.S.A.* 1980, 77, 3115.
- (84) Dill, K. A.; Flory, P. J. *Proc. Natl. Acad. Sci. U.S.A.* 1981, 78, 676.
- (85) Marqusee, J. A.; Dill, K. A. *J. Chem. Phys.* 1986, 85, 434.
- (86) Sander, L. C.; Callis, J. B.; Field, L. R. *Anal. Chem.* 1983, 55, 1068.
- (87) Seelig, J. Q. *Rev. Biophys.* 1977, 10, 353.
- (88) Gilpin, R. K. *J. Chromatogr. Sci.* 1984, 22, 371.
- (89) Gilpin, R. K.; Gangoda, M. E. *J. Chromatogr.* 1983, 21, 352.
- (90) Sindorf, D. W.; Maciel, G. E. *J. Am. Chem. Soc.* 1983, 105, 1848.
- (91) White, S. H.; King, G. I.; Cain, J. E. *Nature* 1981, 290, 161.
- (92) Naghizadeh, J.; Dill, K. A. *J. Chem. Phys.*, submitted.

- (93) Tomellini, S. A.; Shu, S-H.; Fazio, F. D.; Hartwick, R. A. *HRC & CC, J. High Resolut. Chromatogr. Chromatogr. Commun.* **1985**, *8*, 337.
- (94) Miller, M. L.; Linton, R. W.; Bush, S. G.; Jorgenson, J. W. *Anal. Chem.* **1984**, *56*, 2204.
- (95) Hennion, M. C.; Picard, C.; Caude, M. *J. Chromatogr.* **1978**, *166*, 21.
- (96) De Young, L. R.; Dill, K. A. *Biochemistry* **1988**, *27*, 5281.
- (97) Martire, D. E.; Boehm, R. E. *J. Phys. Chem.* **1983**, *87*, 1045.
- (98) Kelusky, E. C.; Fyfe, C. A. *J. Am. Chem. Soc.* **1986**, *108*, 1746.
- (99) Lochmüller, C. H.; Colborn, A. S.; Hunnicutt, M. L.; Harris, J. M. *J. Am. Chem. Soc.* **1984**, *106*, 4077.
- (100) Lochmüller, C. H.; Colborn, A. S.; Hunnicutt, M. L.; Harris, J. M. *Anal. Chem.* **1983**, *55*, 1344.
- (101) *CRC Handbook of Chemistry and Physics*; CRC Press: Boca Raton, FL.
- (102) Morel, D.; Tabar, K.; Serpinet, J.; Claudy, P.; Letoffe, J. M. *J. Chromatogr.* **1987**, *395*, 73.
- (103) Kessaissia, Z.; Papirer, E.; Donnet, J.-B. *J. Colloid Interface Sci.* **1981**, *79*, 257.
- (104) Hansen, S. J.; Callis, J. B. *J. Chromatogr. Sci.* **1983**, *21*, 560.
- (105) Morel, D.; Serpinet, J. *J. Chromatogr.* **1981**, *214*, 202.
- (106) Morel, D.; Serpinet, J.; Untz, G. *Chromatographia* **1984**, *18*, 611.
- (107) van Miltenburg, J. C.; Hammers, W. E. *J. Chromatogr.* **1983**, *268*, 147.
- (108) Hammers, W. E.; Verschoor, P. B. A. *J. Chromatogr.* **1983**, *282*, 41.
- (109) McCormick, R. M.; Karger, B. L. *Anal. Chem.* **1980**, *52*, 2249.
- (110) Carr, J. W.; Harris, J. M. *Anal. Chem.* **1986**, *58*, 626.
- (111) McCormick, R. M.; Karger, B. L. *J. Chromatogr.* **1980**, *199*, 259.
- (112) McNally, M. E.; Rogers, L. B. *J. Chromatogr.* **1985**, *331*, 23.
- (113) Carr, J. W.; Harris, J. M. *Anal. Chem.* **1987**, *59*, 2546.
- (114) Burke, M. F.; Golding, R. D. 1987 Pittsburgh Conference and Exposition, Abstract No. 532.
- (115) Colin, H.; Guiochon, G. *J. Chromatogr.* **1978**, *158*, 183.
- (116) Jaroniec, M.; Martire, D. E. *J. Chromatogr.* **1987**, *387*, 55.
- (117) Jaroniec, M.; Martire, D. E. *J. Chromatogr.* **1986**, *351*, 1.
- (118) Tchapla, A.; Colin, H.; Guiochon, G. *Anal. Chem.* **1984**, *56*, 621.
- (119) Tanaka, N.; Sakagami, K.; Araki, M. *J. Chromatogr.* **1980**, *199*, 327.
- (120) Tanaka, N.; Tokuda, Y.; Iwaguchi, K.; Araki, M. *J. Chromatogr.* **1982**, *239*, 761.
- (121) Naghizadeh, J.; Dill, K. A., in preparation.
- (122) Rohrbaugh, R. H.; Jurs, P. C. *Anal. Chem.* **1987**, *59*, 1048.
- (123) Lamparczyk, H.; Nagoshi, T.; Jinno, K. *Chromatographia* **1987**, *23*, 473.
- (124) Lochmüller, C. H.; Thompson, M. M.; Kersey, M. T. *Anal. Chem.* **1987**, *59*, 2637.
- (125) Sentell, K. B.; Dorsey, J. G. *J. Chromatogr.* **1989**, *461*, 193.