

NMR under High Gas Pressure

ISTVÁN T. HORVÁTH* and JOHN M. MILLAR*

Corporate Research Laboratories, Exxon Research and Engineering Company, Annandale, New Jersey 08801

Received July 8, 1991 (Revised Manuscript Received August 16, 1991)

Contents

I. Introduction	1339
II. NMR Spectroscopy under High Pressure	1340
A. Probes for Observation under Hydrostatic Pressure	1340
B. Methods for Observation under Gas Pressure	1341
1. Modified Hydrostatic Probes	1341
2. Toroidal Detection Probes	1341
3. Glass Tubes	1342
4. Sapphire Tubes	1342
5. Vespel Tubes	1343
III. Applications of NMR under High Gas Pressure	1343
A. On-Line Monitoring of Chemical Reactions	1344
1. Activation of Molecular Hydrogen	1344
2. Detection of an Alkyl Ethylene Intermediate during Ethylene Polymerization	1344
3. Catalytic Hydroacylation of Ethylene	1344
4. Thermal Degradation of PVC	1345
5. Coal Liquefaction	1345
B. Investigations of Equilibrium Systems	1346
1. Hydrogen Exchange	1346
2. Carbon Monoxide Exchange	1346
3. Carbon Dioxide Exchange	1348
4. Exchange of Coordinated Cyclopentadienyl Ligands	1348
C. Utilization of Supercritical Fluids	1348
1. Resolution Enhancement of Quadrupolar Nuclei	1348
2. Supercritical Fluid Chromatography Using NMR Detection	1349
3. Homogeneous Catalysis in Supercritical Fluids	1349
IV. Acknowledgment	1349
V. References	1350



István T. Horváth was born in Budapest, Hungary and received his Diploma in Chemical Engineering (1977) and Ph.D. in Chemistry (1979), both at Veszprém University, Veszprém, Hungary. He spent two years at the Veterinary University, Budapest as an assistant professor and a year at the Chinoi Pharmaceutical and Chemical Company as a research engineer. He was a postdoctoral research associate at Yale University between 1982 and 1984. After spending three years at the Swiss Federal Institute of Technology (ETH), Zurich, Switzerland as a scientific co-worker, he moved to Exxon Research and Engineering Company in 1987. His research interests include homogeneous catalysis, organometallic chemistry, and the application of high pressure spectroscopy.



John M. Millar was born in Cumberland, MD and received his B.S. degree, Magna Cum Laude from West Virginia University (1980) and did his Ph.D. at the University of California, Berkeley under Alexander Pines (1986). After postdoctoral work with Kurt Zilm at Yale University he moved to Exxon Research and Engineering Company, where he has been since 1989. His research interests include the development of NMR techniques and hardware and their applications to catalysis, colloids, and organometallic chemistry.

I. Introduction

Understanding the mechanisms of chemical reactions is a crucial part of the advance of chemistry. As many chemical reactions are accompanied by a color change, visual inspection was perhaps the first application of in situ spectroscopy. The application of various spectroscopic techniques for mechanistic studies and reaction monitoring has become one of the most important developments of contemporary chemistry. Since many important reactions involve liquids under high gas pressure, high-pressure spectroscopic techniques have been developed. These high-pressure chemical processes are generally used to increase the concentration of gases in solution, leading to faster and more economical reaction rates or beneficial shifts in chemical

equilibria. High-pressure techniques are also important to investigate systems involving autogenic pressures which result from reactions performed at high temperatures in closed vessels. The two most frequently used high-pressure spectroscopic techniques are high-

pressure infrared (IR)¹ and high-pressure nuclear magnetic resonance (NMR)^{2a} spectroscopy. Although NMR has the disadvantages of relatively low sensitivity and long time scale, the chemical shifts and couplings obtained can provide detailed structural, kinetic and dynamic information. High-pressure NMR experiments have been performed for almost 40 years using techniques ranging from hydrostatic methods employing hydraulic presses and titanium alloy vessels to the use of glass and sapphire tubes. In this review we shall try to describe some of the more important designs and methods for these experiments. We wish to emphasize that we shall discuss *only* those applications of NMR under high gas pressure which have direct relevance to synthetic chemistry. Many important studies have been performed to explore the effect of extremely high hydrostatic pressure on molecular properties and these have been reviewed in a recent monograph.^{2a}

Since the high-pressure NMR systems developed to date are best used for measurements in solution, most of the reported applications are concerned with liquid-phase reactions involving gases. Many of these studies are concerned with the mechanisms of various liquid-phase homogeneous catalytic reactions. We will show examples of how high-pressure NMR has been used successfully to follow kinetics and to determine thermodynamic data for equilibria. In addition, we shall show cases of how high-pressure NMR has been used to study systems in which high temperatures in closed systems result in autogenic high pressures. Finally, the application of supercritical fluids as solvents for chemical reactions is an attractive and emerging new area for chemical transformations. Using high-pressure NMR they can also be used to obtain high-resolution NMR spectra of quadrupolar nuclei and as a detector in supercritical fluid chromatography. Although we have made every effort to include all pertinent references of the subject matter, we regret any inadvertent omissions.

It should be emphasized that special precaution should be taken at all stages of assembly, testing, and use of any kind of high pressure NMR apparatus because of the hazards involved.

II. NMR Spectroscopy under High Pressure

Although we are interested in the study of chemical reactions under high *gas pressure* by NMR, we will first treat the hydrostatic methods in which some device is used to transmit hydrostatic pressure to the sample. Although these elegant methods are generally used to study physical properties,^{2b} the construction of the apparatus is quite relevant, since with modification it can be employed for chemical studies under gas pressure.

A. Probes for Observation under Hydrostatic Pressure

Hydrostatic probes were developed to study physical properties of liquids under pressures as high as 10 000 atm. These probes utilized a hydraulic press or similar device in combination with a pressurizing fluid to transmit hydrostatic pressure to the sample. Probes of this type possessing a heavy duty pressure vessel offer the greatest range of pressure and the utmost in safety.

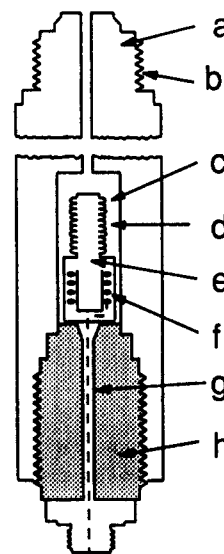

Figure 1. High-pressure NMR probe of Benedek and Purcell.³ (a) main body of pressure bomb, (b) thread for connection to high-pressure press, (c) pressurizing fluid, led into probe via $\frac{1}{8}$ -in. hole down along axis of probe, (d) bellows which is deformed by pressurizing fluid, (e) sample chamber, (f) rf coil, (g) rf coil leads, (h) bottom plug.

The first high-pressure NMR experiments were performed by Benedek and Purcell in 1954 using apparatus closely resembling that in use today.³ Using apparatus and techniques owing to Bridgman,⁴ they could achieve pressures up to 10 000 atm and used this capability to observe the variation of proton relaxation times with viscosity. Their apparatus, designed for an electromagnet, consisted of a hollow beryllium copper cylinder (Berylco 25) connected to a hydraulic press (Figure 1).³ A plug with feed throughs for the leads of the NMR coil closed off the bottom of the cylinder. Attached to this bottom plug sat a sealed sample chamber and the remaining internal space of the cylinder was filled with a fluid which could be pressurized via the hydraulic press. The top of the sample chamber consisted of a metal bellows which was compressed as the hydraulic fluid was pressurized, thus transmitting pressure to the sample. Sample size and resolution were not specified and pressure was measured with a manganin wire gauge.

The beryllium-copper alloy was chosen because of its strength, its ease of machining, and its nonmagnetic properties, as has been discussed in detail elsewhere.⁵⁻⁷ In constructing probes of Berylco 25, one is recommended to first perform rough machining, followed by heat treating and final machining to tolerance.^{5,7} In this alloy, significant variation in the level of paramagnetic impurities has been observed,⁸ and ultrasonic testing is recommended to detect bubbles of gas occasionally present.⁶ Use of the material above 80 °C can also shorten its lifetime.^{7,9} Since beryllium is highly toxic, all grinding should be done with suitable protection. In contrast to beryllium-copper, the titanium alloy IMI-680 needs no special heat treatment and retains its strength for extended periods at 400 °C and has been reported in use up to 5000 atm from -50 to 350 °C.⁷

Several different pressurization fluids have been used depending on the temperature range and the observed nucleus. For example, CS₂ has been used for low temperatures to -50 °C and tetrachloroethylene above room

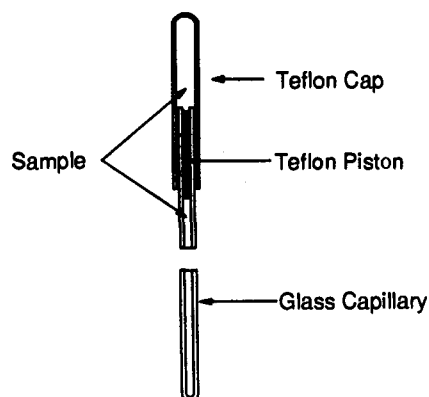

Figure 2. High pressure NMR sample cell of Earl, Vanni, and Merbach.⁹ A glass capillary (Wilmad) and teflon cap are pressurized by an external pressurizing fluid to transmit pressure to a sample contained within (see text).

temperature. Other examples are given elsewhere.^{6,10,11}

The bellows employed by Benedek and Purcell³ was replaced by a capillary/teflon cap arrangement by Merbach and co-workers, who describe a probe for the electromagnet of a Bruker WP-60 NMR spectrometer.⁹ Their design consists of a beryllium-copper vessel, which is pressurized externally with a hydraulic pump. The sample cell is constructed from a Wilmad glass capillary (1.5 mm o.d./1.1 mm i.d.), a teflon piston which fits completely inside the capillary and a teflon cap which fits snugly along the outside of the capillary (Figure 2). The piston and the liquid sample are placed inside the glass capillary, with sample above and below the piston. The cap is also filled with sample and is placed over the glass capillary in such a way that the force of a pressurizing fluid pushes the teflon cap over the capillary and pressurizes the sample within. Pressures up to 3000 atm are reported with this method although the burst pressure of the vessel was calculated to be greater than 10 000 atm using the formula

$$P_{\text{burst}} = (2/\sqrt{3})\sigma_y \ln (\text{o.d./i.d.}) \quad (1)$$

where σ_y , the 2% proof stress, is approximately 10 000 atm for Berylco.⁴ The apparatus permits a temperature range of -10 to 80 °C as measured with a Pt resistor. Pressure variation of its resistance required a correction of about 1.5 °C/1000 atm.

A deformable Vespel sample holder was used by Ilgen and van Jouanne in similar fashion for a probe designed for a Varian XL-100 electromagnet.¹⁰ Their sample holder sits inside a Berylco 25 pressure vessel and deformation of the Vespel by a pressurizing fluid (CCl_4) transmits pressure to the sample. Their tuning circuit is described in detail.¹⁰

Proton NMR of gaseous or liquid samples could be studied under high pressure in a pressure vessel system described by Oldenziels and Trappeniers.⁸ In the former case, a compressor filled with the gas of interest was connected to the sample area of the probe, requiring relatively large amounts of the gas. For liquids, the compressor used nitrogen gas acting on a piston which then acted on the sample. A sealed glass tube of benzene sat in the center of the sample region and served as a pressure independent reference. The sample tube could be spun rapidly using a dc motor located inside the pressure vessel, producing overall line widths as low as 0.01 ppm (0.6 Hz) up to 2500 atm of pressure.

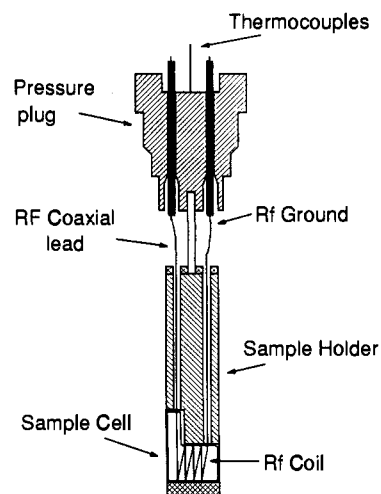

Figure 3. High-resolution sample insert of Heaton, Jonas, and co-workers.^{12,13} This sample insert, described in the text, is placed inside a cylindrical high-pressure vessel.

B. Methods for Observation under Gas Pressure

1. Modified Hydrostatic Probes

In 1981, using a modification of some of Jonas' earlier designs, Heaton, Jonas, and co-workers reported a single-tuned high-resolution ^{13}C probe suitable for a wide-bore superconducting magnet.^{12,13} The probe consisted of a 6Al-4V alloy titanium pressure vessel surrounded by thermal insulation and a sample insert possessing a 1-mL open sample volume (Figure 3). The pressure vessel had an o.d. of 57 mm and an i.d. of 14 mm with leads for the NMR coil passed into it via feed-throughs. Temperature was controlled by circulation of liquids through copper tubing surrounding the titanium vessel.¹⁴ The open cell allowed pressurization with the probe inside the magnet and operation was reported up to 850 atm from -60 to 25 °C using H_2/CO mixtures. The upper temperature was reportedly limited somewhat due to H_2 embrittlement. The probe has been used with both solenoidal and Helmholtz coils, with the former reported to have a sensitivity 3-4 times greater than the latter and typical carbon line widths of about 0.5 ppm (25 Hz).¹² Later reports indicate line widths of 0.06 ppm using a Helmholtz coil arrangement that employed 5-mm tubes.¹⁵

A double-tuned version of the probe has also been described using tuning elements located outside of the titanium pressure vessel.¹⁵ Ceramic chip capacitors (American Technical Ceramics AT-100 series) were employed as tuning elements inside the vessel and withstood pressures up to 5000 atm. Vander Velde and Jonas later reported a higher sensitivity version using an 8-mm diameter sample cell which could be stirred via a solenoid mechanism.¹⁴ This crossed coils double resonance probe was capable of 0.01-ppm (2-Hz) resolution in operation from -50 to 150 °C.

2. Toroidal Detection Probes

Submerged toroidal detection coils were shown to have improved sensitivity and resolution relative to traditional probes, in a design by Rathke intended for studies of homogeneous catalysts.¹⁶ His probe allows examination of pressurized reactor effluent and is capable of ^1H line widths of 5 Hz (0.02 ppm) at 7.05 T over a temperature range of 25 to 175 °C. The probe

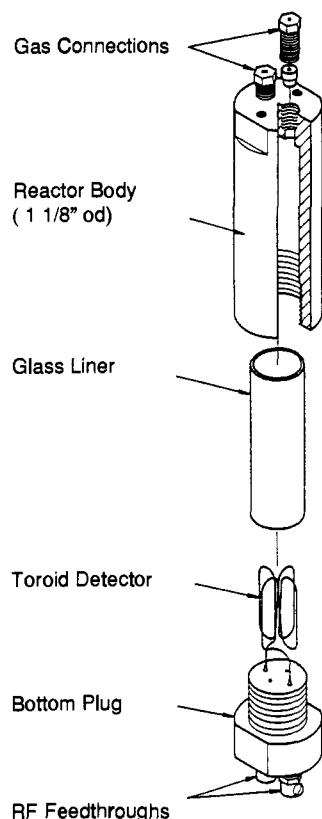

Figure 4. Schematic of Rathke's toroidal detection probe (reprinted from ref 16; copyright 1989 Academic).

consists of a toroidal rf coil inside a pressure vessel, with rf and pressurization fittings mounted on top and bottom, respectively (Figure 4). Construction details for the probe as well as for the rf circuitry allowing $^{13}\text{C}/^1\text{H}$ or $^{59}\text{Co}/^1\text{H}$ double resonance operation are described. The unit volume signal-to-noise ratio (signal/coil volume) of the best toroidal coils was significantly better than that of a solenoid or a commercial nonspinning 10-mm multinuclear probe. The inherent rf field inhomogeneity of the toroidal coils resulted in 180° pulse lengths ranging from two to four times the length of the pulse length for maximum signal.¹⁶

3. Glass Tubes

Sealed glass ampoules have been used at high pressure by a number of groups, with the burst pressure limited by the ratio of the outer diameter to the inner diameter as described in eq 1. Several authors have recommended that particular attention be paid to producing high quality glass seals and that all samples should be tested outside of the magnet before use.

Gordon and Dailey examined methane and ethane up to 300 atm using pyrex tubes (5 mm o.d./0.5 mm i.d.) and they recommended 20 atm as the limit for thinner tubes (5 mm o.d./3 mm i.d.),¹⁷ although others have gone up to 50 atm using the thinner size.¹⁸ Jameson et al. have examined Xe gas up to 200 atm in borosilicate glass tubes (3.9 mm o.d./1.2 mm i.d.).¹⁹ Their procedure was to blow a constriction in the tube, anneal, pull the constriction to a smaller diameter, introduce a sample, and then seal off. Tubes with a larger 2.2 mm i.d. could be used safely only to about 50 atm. Variable-temperature experiments were also reported using pressures up to 122 atm and temperatures up to 170

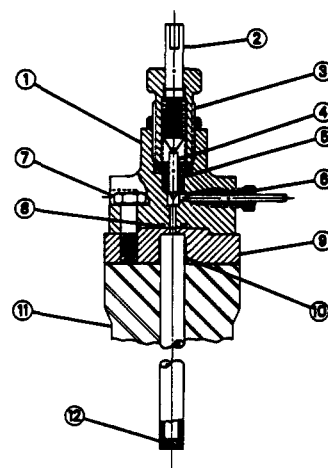

Figure 5. Schematic drawing of Roe's Ti alloy valve and sapphire tube assembly: (1) valve body, (2) valve stem drive handle, (3) stem drive and packing gland, (4) nonrotating stem, (5) packing assembly, (6) gas inlet port for $1/16$ -in. tubing, (7) assembly screw (total of four), (8) Viton O-ring seal, (9) tube mounting flange, (10) epoxy sealant, (11) spinner turbine, (12) sapphire tube (reprinted from ref 25; copyright 1985 Academic).

$^\circ\text{C}$.²⁰ In order to decrease the possibility of explosion inside the magnet, samples were first tested at temperatures above those intended for the NMR experiments. More recently, Wayland and co-workers describe the use of commercially available heavy walled 5- and 10-mm tubes up to 23 atm (e.g. 5 mm o.d./2.16 mm i.d.), from -53 to 10°C .²¹

For higher pressures, etching with aqueous HF is recommended.²² This procedure apparently removes tiny fractures and flaws in glass tubes and allows them to be used more safely at higher pressures.²³

4. Sapphire Tubes

Roe, following a suggestion by King,²⁴ reported in 1985 that sapphire tubes (5 mm o.d./3.4 mm i.d.) could be fastened to titanium alloy heads to perform experiments using pressures up to about 130 atm and a temperature range of -100 to 150°C (Figure 5).²⁵ The single-crystal sapphire tubes^{26a} are glued to a titanium alloy flange (5Al-4V alloy) with an epoxy adhesive.^{26b} A Ti alloy valve assembly allowing pressurization is then screwed into the flange and sample volume of about 0.3–0.4 mL is obtained. The entire tube and valve assembly weigh about 110 g and generally spins in a commercial magnet, albeit with an increase in the normal spinner air pressure. Even though the tubes have a flat bottom surface and do not meet the specifications of typical NMR tubes, ^1H line widths obtained on a 360-MHz instrument were about 1 Hz, with some line shape distortion.

Horváth and Ponce have recently published a new version of this titanium head/sapphire tube arrangement (Figure 6), which allows the use of either 5- or 10-mm tubes.²⁷ In addition to the larger sample size in the latter, their design uses a simple and light-weight valve system. Optional teflon O-rings can be used to isolate reactants from the glue holding together the head and tube. The 10-mm tube is light enough (73 g) to allow spinning in most spectrometers and 10-mm proton line widths of 0.5 Hz are obtained at 300 MHz.

Robert and Evilia have also used sapphire tubes at somewhat higher pressures, but test each sample while

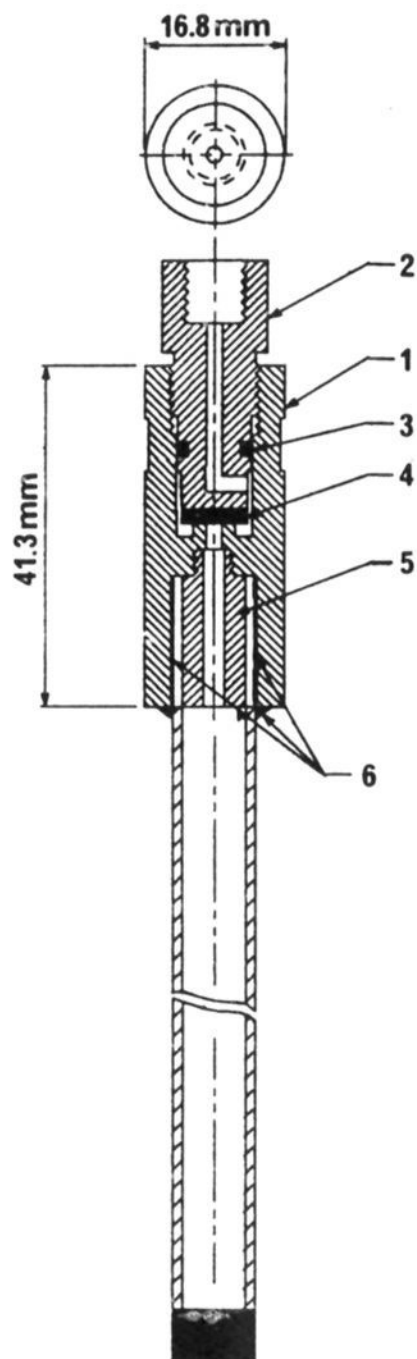

Figure 6. Schematic drawing of titanium valve and sapphire tube assembly of Horváth and Ponce.²⁷ (1) valve body, (2) valve stem, (3) Viton O-ring, (4) glass-filled teflon valve seat, (5) aligner for sapphire tube, (6) adhesive.

pressurized for at least 12 h before actual use.²⁸ They have found that annealing improves the strength of the sapphire tube, since none of their annealed tubes have exploded but several unannealed ones have. They also suggest use of air convection rather than steam for heating the tubes since sapphire's strength is reduced in the presence of steam.²⁹

Safety considerations are of paramount importance in the use of these tubes and cannot be stressed enough.^{24,27,30} Roe subjected his tubes to numerous tests before use but stated emphatically that it is impossible to specify a safe upper pressure range and that the history of a tube could affect its failure. One tube had a burst pressure of 1000 atm and it was estimated that pressures of about 130 atm offered a reasonable margin of safety. He also recommended the use of safety shields at all times during sample handling and that *laboratory personnel should never be exposed directly to the pressurized tube*. The sapphire tubes are essentially chemically inert, but being single crystalline in nature, they are sensitive to vibration, and one is therefore cautioned to avoid a hydrosonic bath.

5. Vespel Tubes

Thick-walled Vespel tubes have been used by Merbach's group at pressures to about 1000 atm (Figure

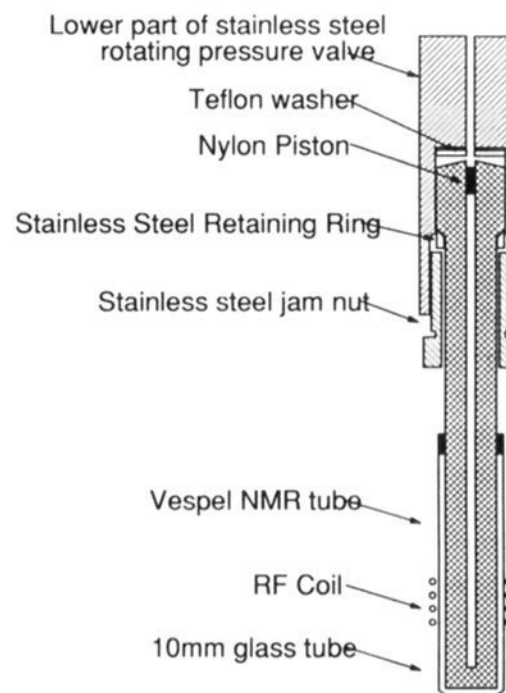

Figure 7. Rotatable high-pressure NMR tube of Vanni, Earl, and Merbach.³¹

7).³¹ This polyimide material was chosen because of its resistance to chemical attack, and the authors used tubes with o.d. and i.d. of 8 and 2 mm, respectively. The upper portion of the tube is connected to a high pressure valve mounted on bearings to allow rotation about the magnetic field axis. Connection to a pump allows pressurization. This is then disconnected to allow rotation of the valve/tube assembly. Alignment was rather difficult and time consuming; consequently their line shapes suffered from spinning sidebands. Resolution was reasonably good (0.03 ppm at 60 MHz), but was limited by the susceptibility of the polyimide, which apparently varied from batch to batch. Variable temperature experiments could be performed with the apparatus, although details were not given. After several pressurizations, noticeable deformation of the Vespel tubes required their replacement.³¹

Kinrade and Swaddle have reported a design which spins a Vespel sample tube in a commercial instrument and has been routinely used at 200 °C and 16 atm.^{31b} The design consists essentially of a Vespel tube, a Vespel spinner turbine, specific to a particular instrument, and a Vespel valve head which threads into the spinner turbine and thus secures the tube. Since the turbine was the only component specific to a particular probe, the other parts could be interchanged, allowing use on several instruments. Sixteen-millimeter tubes having both 13 and 9 mm i.d.'s were used, providing at least a factor of 5 safety margin over calculated pressure ceilings. A teflon inner sleeve, made with sealed-off teflon tubing, protected the tube from chemical attack.

III. Applications of NMR under High Gas Pressure

Most of the reported applications of high-pressure NMR are concerned with reaction in systems containing a liquid and a gas. For example, many of these studies are related to the mechanisms of various liquid-phase homogeneous catalytic reactions with the ultimate goal being to gain enough information to construct (or reconstruct) the catalytic cycle.³²

We shall illustrate how high-pressure NMR is one of the most powerful methods for real-time monitoring of reactions as well as for studying chemical equilibria. It

SCHEME I

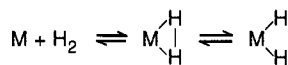

has been successfully used to follow the overall kinetics of catalytic reactions, to investigate individual steps of catalytic cycles, and to determine thermodynamic data for equilibria between various species. Since many chemical processes are performed at very high temperatures in closed systems resulting in autogenic high pressures, high-temperature and -pressure NMR has become an essential tool for mechanistic studies. Finally, high-pressure NMR is a convenient and informative method for the investigation of chemical reactions performed in supercritical fluids.

A. On-Line Monitoring of Chemical Reactions

The first application of high-pressure NMR for on-line monitoring was reported by Heaton, Jonas, and co-workers.^{12,13} They studied the mechanistic aspects of the catalytic synthesis of ethylene glycol from CO and H₂ in the presence of rhodium carbonyls. High-pressure ¹³C NMR revealed that treatment of an acetone-*d*₆ solution of (NMe₃C₆H₄CH₂)₂[Rh₁₂(CO)₃₀] with 575 atm of CO at -52 °C results in a progressive transformation of [Rh₁₂(CO)₃₀]²⁻ into [Rh₅(CO)₁₅]⁻. There is evidence for unreacted [Rh₁₂(CO)₃₀]²⁻ even after 3 h and there is no further reaction upon addition of H₂ to give a total pressure of 850 atm (CO/H₂, 2.1:1) at this temperature. Warming the solution to 25 °C followed by cooling to -33 °C leads to the complete formation of [Rh₅(CO)₁₅]⁻. No data were reported at higher temperatures, however.

1. Activation of Molecular Hydrogen

Activation of molecular hydrogen by transition-metal complexes plays an important role in the homogeneous catalytic reduction of unsaturated organic compounds³³ as well as in other catalytic processes utilizing syngas (H₂/CO).³⁴ One of the most frequently observed activation paths involves the oxidative addition of H₂ to a coordinatively unsaturated species resulting in a side-on coordinated hydrogen complex,³⁵ followed by the homolytic cleavage of the H-H bond to form a dihydride species (Scheme I). A coordinatively unsaturated species can be generated by thermolysis or photolysis of a coordinatively saturated complex via ligand elimination. Because such intermediates generally have short lifetimes at ambient temperature, low-temperature photolysis can provide a large enough concentration of the required species to study the reaction with H₂. Since the rate of H₂ addition can slow down significantly at low temperatures, the application of high pressure of H₂ can be used to increase the H₂ concentration enough to observe and study various products of H₂ addition.

The photochemical activation of molecular hydrogen by Fe(CO)₅ was studied by high-pressure NMR and ESR between -80 and -110 °C under 34 atm H₂ or 60 atm H₂/CO.³⁶ The formation of two diamagnetic products, H₂Fe(CO)₄ and H₂Fe₂(CO)₈, was identified by proton NMR. H₂Fe(CO)₄ is believed to be produced initially by oxidative addition of H₂ to the 16-electron coordinatively unsaturated {Fe(CO)₄} fragment formed by photoejection of a CO from Fe(CO)₅. The subse-

SCHEME II

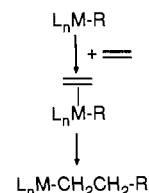

quent reaction of H₂Fe(CO)₄ with another {Fe(CO)₄} species could give the dinuclear H₂Fe₂(CO)₈. The formation of several paramagnetic complexes was detected by high-pressure ESR. The presence of HFe(CO)₄[•], HFe₂(CO)₈[•], and HFe₃(CO)₁₁[•] were established, and the formation of two trihydride species, H₃Fe(CO)₄[•] and H₃Fe₂(CO)₇[•] was proposed. Isotopic substitution studies with deuterium, ¹³CO, and ⁵⁷Fe were used to structurally characterize these labile radical species.³⁶

The addition of hydrogen to the coordinated RN=C(R¹)C(H)=NR ligand in FeRu(CO)₆[RN=C(R¹)C(H)=NR] resulting in FeRu(CO)₆[N(R)CR¹HCH₂N(R)] was studied by Vrieze and co-workers.³⁷ The addition of deuterium has revealed that the reactions result in a stereospecific trans addition over the central C-C bond of the N=CC=N skeleton of the R-DAB ligand. The reaction is very slow below 70 °C at pressures between 20 and 70 atm. The conversion of FeRu(CO)₆[*i*-PrN=CH-CH=N(*i*-Pr)] into FeRu(CO)₆[(*i*-Pr)NCH₂CH₂N(*i*-Pr)] at 110 °C and 60 atm H₂ is shown on Figure 8. The rate of conversion is first order in the concentration of both the complex and H₂. No intermediates have been observed.

2. Detection of an Alkyl Ethylene Intermediate during Ethylene Polymerization

The transition-metal-catalyzed polymerization of olefins is an extremely important industrial process and has been studied over many years. The most commonly accepted mechanism of the carbon-carbon bond formation involves a β -migratory insertion reaction occurring via an intermediate alkyl olefin complex (Cossee-Arlman mechanism, Scheme II).³⁸⁻⁴⁰ The first such intermediate, a cobalt alkyl ethylene complex, was recently detected by investigating a Co(III) catalyst system for ethylene polymerization using high-pressure NMR.⁴¹ When a solution of [C₅Me₅Co(CH₂CH₂- μ -H)(P(OMe)₃)](BF₄) in CD₂Cl₂ is treated with 4-atm ¹³C-enriched and 34-atm unlabeled ethylene at -80 °C, the ¹³C NMR at -70 °C showed signals at 56.5 ppm (d, *J*_{C-C} = 44 Hz) and 66.5 ppm (d, *J*_{C-C} = 44 Hz). These resonances were assigned to the nonequivalent ethylene carbons in [C₅Me₅Co(CH₂CH₃)(η^2 -C₂H₄)(P(OMe)₃)]-[BF₄]. It should be noted, however, that resonances due to the higher cobalt alkyl-ethylene homologues appear at similar chemical shifts.

3. Catalytic Hydroacylation of Ethylene

The indenyl complex (η^5 -C₉H₇)Rh(η^2 -C₂H₄)₂ is an excellent catalyst (or catalyst precursor) for intermolecular hydroacylation, the addition of aldehydes to alkenes (Scheme III). The addition of PhCHO to ethylene occurs rapidly at 100 °C and 68 atm ethylene pressure in benzene. High-pressure NMR has established that during the addition of C₆H₅¹³CHO to ethylene only C₆H₅¹³C(O)CH₂CH₃ was observed, and no

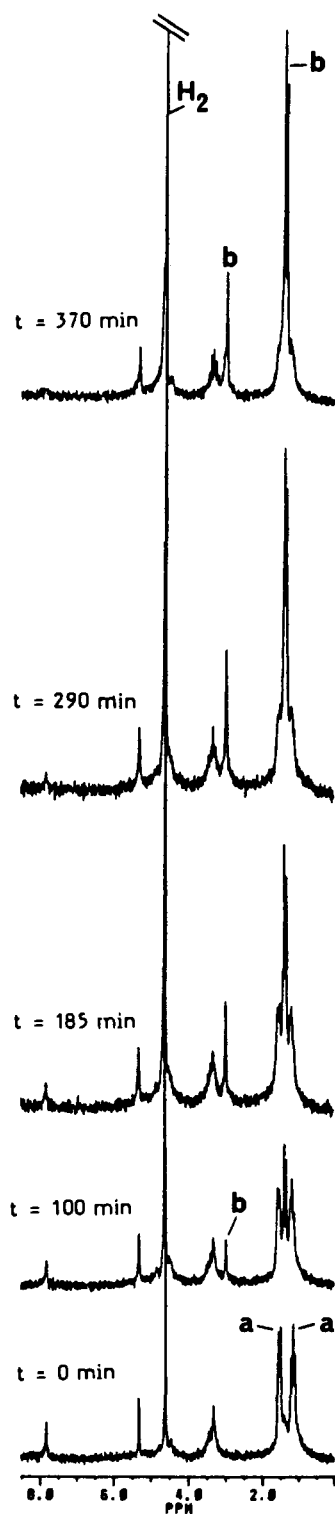
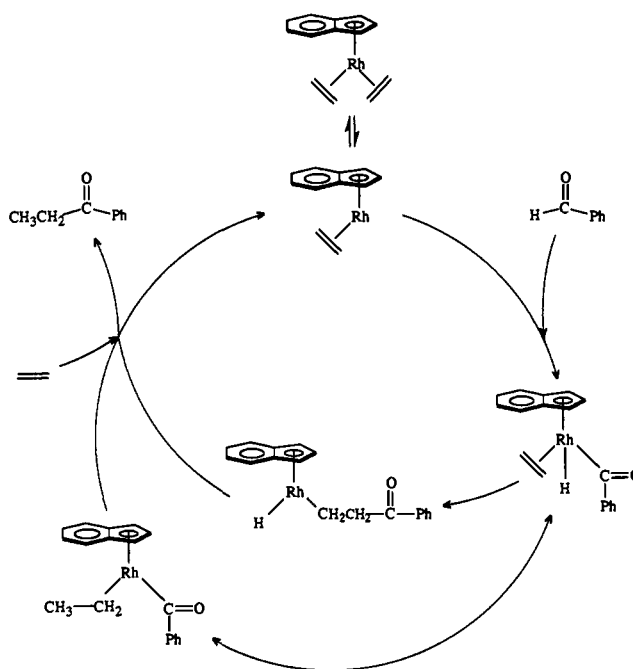

Figure 8. The conversion of $\text{FeRu}(\text{CO})_6[\text{i-PrN}=\text{CH}-\text{CH}=\text{N}-(\text{i-Pr})]$ (a) into $\text{FeRu}(\text{CO})_6[\text{N}(\text{i-Pr})\text{CH}_2\text{CH}_2\text{N}(\text{i-Pr})]$ (b) at 110°C under 60 atm H_2 (reprinted from ref 37; copyright 1989 American Chemical Society).

resonances due to rhodium carbonyls or dissolved CO were detected.⁴² These results show that the intermediate acyl rhodium species, formed by the oxidative addition of the aldehyde C-H bond to the rhodium metal center, does not undergo decarbonylation under catalytic conditions. The addition of $\text{C}_6\text{D}_5\text{CDO}$ to ethylene was also studied by high-pressure NMR and showed no deuterium incorporation to unreacted ethylene and statistical scrambling of exactly one deu-

SCHEME III



terium atom between methyl and methylene sites. These results indicate that the insertion of ethylene into the Rh-D bond must take place rapidly and reversibly, and this equilibrium must be established significantly faster than either the reductive elimination of the aldehyde or the formation of the product ketone. These results also suggest that only one ethylene is bound to the rhodium during the activation of the aldehyde, indicating associative mechanisms A or B (Scheme III).

4. Thermal Degradation of PVC

Understanding the mechanism of thermal degradation of polymers is important for the development of temperature-resistant materials as well as for the thermal recycling of such materials. Most polymers in the molten state at high temperatures are in an equilibrium where cracking, polymerization, and polycondensation reactions occur. Since the cracking reaction could result in significant amounts of gaseous product, high-pressure NMR is an excellent tool for investigating thermal degradation of polymers.⁴³ The thermal degradation of poly(vinyl chloride) (PVC) was studied by ^1H NMR, and the temperature and pressure dependence of the proton spectra is shown in Figure 9. At 450°C and 145 atm N_2 pressure the formation of aromatic rings was observed, and the aromatic protons represented 30% of the total protons. On further heating the spectrum showed the early growth stages of liquid crystalline phases.

5. Coal Liquefaction

Liquefaction of coal can be used to obtain hydrocarbon liquids. Since coals have a H/C ratio below one, most of the liquefaction schemes involve the depolymerization of the coal carbon framework followed by the addition of hydrogen. The source of the hydrogen can be molecular hydrogen, water, or other hydrocarbons with high H/C ratio. Since these processes are performed at very high temperatures and pressures, mechanistic information is scarce. The first in situ

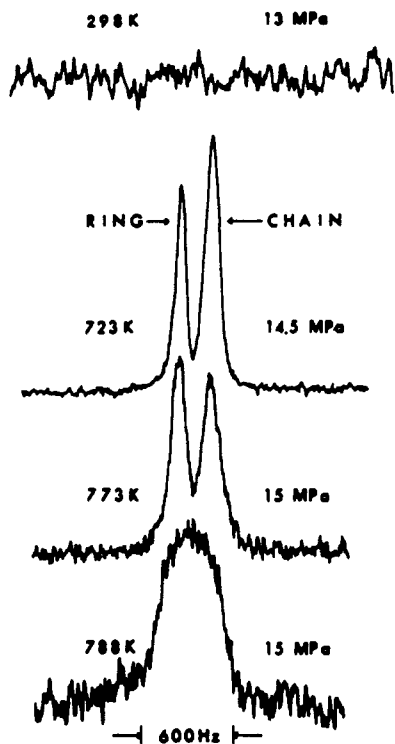

Figure 9. Temperature and pressure dependence of ^1H NMR spectra for TD-PVC (reprinted from ref 43; copyright 1983 Nippon Kagakai).

NMR investigation of a high-temperature and high-pressure coal liquefaction using 1,2,3,4-tetrahydroquinoline (THQ) as solvent and ZnCl_2 catalyst was reported by Shimokawa, Yamada, and co-workers.⁴⁴ Typical ^1H NMR spectra for the Akabira coal/THQ system with and without ZnCl_2 at different temperatures under autogenic pressure conditions are shown on Figure 10. These data combined with ESR measurements were used to elucidate the mechanism during swelling, liquefaction, and coking stages of coal liquefaction.

The formation of formate ion intermediates during the reaction of low-rank coals with carbon monoxide and water at 315 °C and 47 atm CO pressure was detected for the first time by high-pressure NMR (Figure 11).⁴⁵ The concomitant formation of CO_2 via the decarboxylation of the coal and the water-gas shift reaction was observed. Isotope labeling experiments using ^{13}C O and D_2O revealed deuterium incorporation into the coal structure and the ratio of decarboxylation of the coal to the water-gas shift reaction.

B. Investigations of Equilibrium Systems

1. Hydrogen Exchange

Side-on coordinated hydrogen complexes are the first stable intermediates in the activation of molecular hydrogen (Scheme I). The first side-on coordinated hydrogen complex, $(\eta^2\text{-H}_2)\text{W}(\text{CO})_3(\text{PCy}_3)_2$, was discovered by Kubas in 1985 and numerous others have been found since.^{35,46} The possible formation of the analogous chromium compound was first observed by high-pressure infrared spectroscopy (eq 2),⁴⁷ although the side-on $\text{Cr}(\text{CO})_3(\text{PCy}_3)_2 + \text{H}_2 \rightleftharpoons (\eta^2\text{-H}_2)\text{Cr}(\text{CO})_3(\text{PCy}_3)_2$ (2) coordination mode of the hydrogen could not be es-

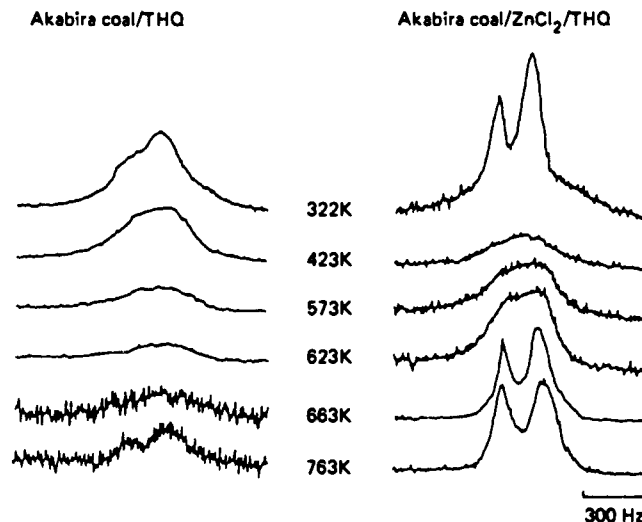

Figure 10. Temperature dependence of ^1H NMR spectra of Akabira coal/THQ in the absence and the presence of ZnCl_2 under autogenic pressure (reprinted from ref 44; copyright 1986 Butterworth).

tablished by IR. High-pressure NMR revealed the reversible formation of $(\eta^2\text{-H}_2)\text{Cr}(\text{CO})_3(\text{PCy}_3)_2$, and T_1 measurements clearly established the presence of a side-on bound molecular hydrogen ligand.⁴⁸ Furthermore, kinetic studies of the elimination of the $\eta^2\text{-H}_2$ ligand between 10 and 54 atm pressure of H_2 revealed that the elimination reaction is a unimolecular process, as expected.

2. Carbon Monoxide Exchange

The chemistry of transition-metal carbonyl complexes has been studied for more than 100 years, and is important due to the numerous transition-metal-catalyzed processes involving carbon monoxide.^{34,49} The hydroformylation of olefins is the most widely used homogeneous catalytic process utilizing CO. It involves the addition of one molecule of CO and H_2 to an olefin in the presence of a transition-metal catalyst resulting in an aldehyde (eq 3). The most frequently used hydro-

$$\text{RCH}=\text{CH}_2 + \text{CO} + \text{H}_2 \rightarrow \text{R}-\text{CH}_2-\text{CH}_2-\text{CHO} \text{ or } \text{R}-\text{CH}(\text{CH}_3)-\text{CHO} \quad (3)$$

formylation catalysts are based on cobalt and rhodium.

It is generally believed that the activation of hydrogen in cobalt-catalyzed hydroformylation occurs either on the coordinatively unsaturated species $\{\text{Co}_2(\text{CO})_7\}$ or $\{\text{acyl-Co}(\text{CO})_3\}$,^{50a} both formed by the elimination of a coordinated carbonyl (eqs 4 and 5). The exchange of

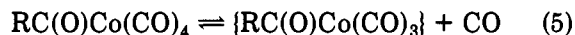
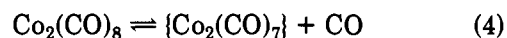

free CO in solution with $\text{Co}_2(\text{CO})_8$ was studied by ^{13}C magnetization transfer techniques up to 75 atm CO pressure between 40 and 80 °C.³⁰ The rates for CO dissociation were found to be independent of pressure up to 75 atm. In a similar study, slightly faster CO exchange was observed between $\text{CH}_3\text{C}(\text{O})-\text{Co}(\text{CO})_4$ and free CO (Figure 12). These results suggest that the loss of CO from $\text{CH}_3\text{C}(\text{O})-\text{Co}(\text{CO})_4$ is accompanied by the formation of an $\{\eta^2\text{-CH}_3\text{C}(\text{O})\text{Co}(\text{CO})_3\}$ ^{50b} intermediate.

While rhodium carbonyls can also be used for the hydroformylation of olefins, the addition of phosphines

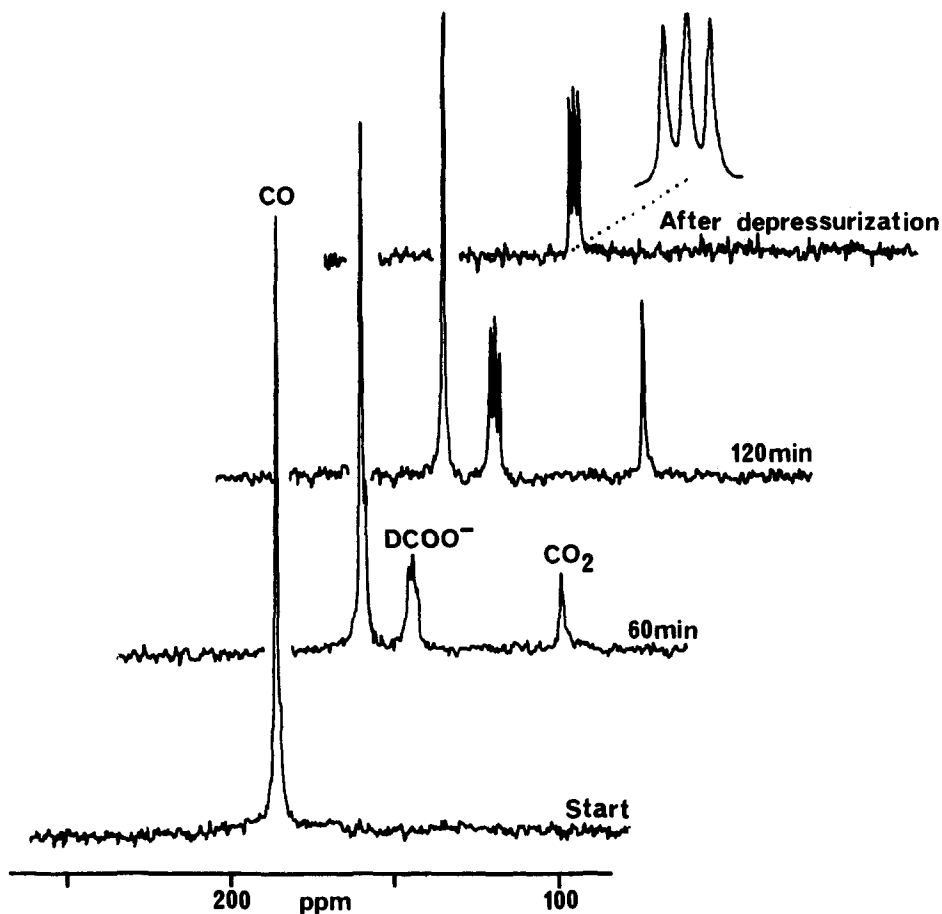

Figure 11. High-pressure ^{13}C NMR spectra of a solution containing 0.25 g of lignite from Martin Lake, TX and 2 g of D_2O at room temperature after pressurization with 700 psi ^{13}CO , heating to 315°C for 60 min, heating to 315°C for 120 min, and depressurization.

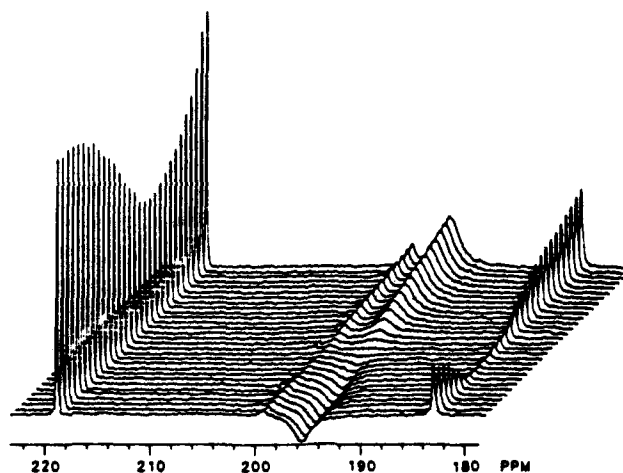
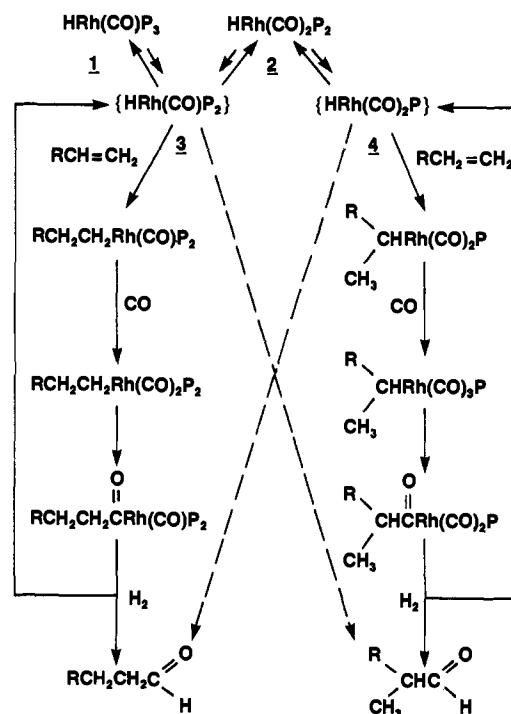

Figure 12. Observed ^{13}C NMR spectral response to selective inversion of the $\text{Co}(\text{CO})_4$ signal (197.1 ppm) of $\text{CH}_3\text{C}(\text{O})\text{Co}(\text{CO})_4$ in methylcyclohexane- d_{14} at 70°C (reprinted from ref 30; copyright 1987 American Chemical Society).

(or phosphites) significantly changes the catalytic activity and selectivity. The total phosphine to rhodium ratio (P/Rh) is one of the most important factors controlling the catalytic performance of any phosphine-modified rhodium hydroformylation catalyst. Heaton, Whyman, and co-workers have recently shown by high-pressure IR and NMR that at $\text{P/Rh} = 1$ (or below) di- and tetranuclear rhodium complexes are present in the solution up to 400 atm CO/H_2 (1:1).⁵¹ No evidence has been obtained for the formation of the monosubstituted hydride species $\text{HRh}(\text{CO})_3(\text{PR}_3)$.

SCHEME IV



Detailed mechanistic studies on the $\text{HRh}(\text{CO})-(\text{PR}_3)_3-\text{PR}_3$ hydroformylation catalyst systems ($\text{P/Rh} > 3$) have clearly established that the two key catalytic species are the coordinatively unsaturated $\{\text{HRh}(\text{CO})(\text{PR}_3)_2\}$ and $\{\text{HRh}(\text{CO})_2(\text{PR}_3)\}$ (Scheme IV).⁵²

SCHEME V

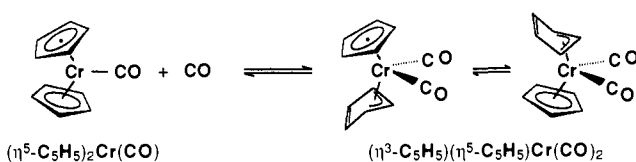

High-pressure NMR has provided ample experimental evidence that the normal/iso ratio of the aldehydes is largely controlled by the competitive reaction of the olefin with intermediates $\{\text{HRh(CO)(PR}_3)_2\}$ and $\{\text{HRh(CO)}_2(\text{PR}_3)\}$ resulting in high or low normal/iso ratio, respectively.⁵³

The reaction of carbon monoxide with (octaethylporphyrin)rhodium dimer, $[(\text{OEP})\text{Rh}]_2$, under pressure was studied by Wayland and co-workers.²¹ It was established by ^1H and ^{13}C NMR that $[(\text{OEP})\text{Rh}]_2$ is in equilibrium with three new species, $[(\text{OEP})\text{Rh}]_2(\text{CO})$, $(\text{OEP})\text{RhC(O)Rh(OEP)}$, and $(\text{OEP})\text{RhC(O)C(O)Rh(OEP)}$. The formation of the latter 1,2-ethanedionyl bridged complex is the only example for double insertion of CO into a metal-metal (Rh-Rh) bond. Although the unfavorable entropy change will prevent most systems from undergoing double CO insertion, in this case the weak Rh-Rh bond, the strong Rh-C(O) bond, and the steric environment of the OEP macrocycle resulted in favorable thermodynamic factors for single and double CO insertion.²¹

3. Carbon Dioxide Exchange

The insertion of carbon dioxide into transition-metal hydrides to afford metalloformates is a quintessential process in the reduction of CO_2 . The mechanistic as-



pects of the CO_2 insertion into $[\text{HCr(CO)}_5]^-$ to yield $[\text{HCO}_2\text{Cr(CO)}_5]^-$ have been studied by the examination of the CO_2 exchange in reaction 7 under pressure.^{54a}

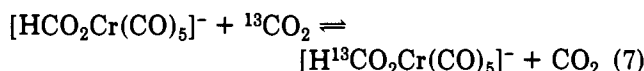

The process is dissociative by character and proceeds through the following steps: (1) CO loss with formation of an intermediate $\text{O}_2\text{-}\eta^2$ species, $[\text{Cr(CO)}_4(\eta^2\text{-O}_2\text{CH})]^-$, (2) rearrangement to an $\text{H}_2\text{O-}\eta^2$ chelate, (3) decarboxylation and recarbonylation, and (4) recarbonylation with $^{13}\text{CO}_2$ in the reverse direction. Similar studies have been performed for tungsten, nickel, and palladium formate complexes.^{54b,c}

4. Exchange of Coordinated Cyclopentadienyl Ligands

The reversible reaction of $(\eta^5\text{-C}_5\text{H}_5)_2\text{Cr(CO)}$ with carbon monoxide under elevated pressure has been studied by high-pressure IR and the formation of a ring-slipped species $(\eta^3\text{-C}_5\text{H}_5)(\eta^5\text{-C}_5\text{H}_5)\text{Cr(CO)}_2$ was suggested (Scheme V).^{55a} Variable-temperature high-pressure NMR has confirmed the formation of a new species containing two different C_5H_5 ligands (Figure 13).^{55b} The C_5H_5 rings undergo concerted ring interchange between η^3 and η^5 coordinations with E_{act} of 13.5 kcal/mol, and the process does not involve CO elimination followed by CO addition. Electronic structure calculations suggest that the interchange occurs through a simultaneous bending and straightening of the two

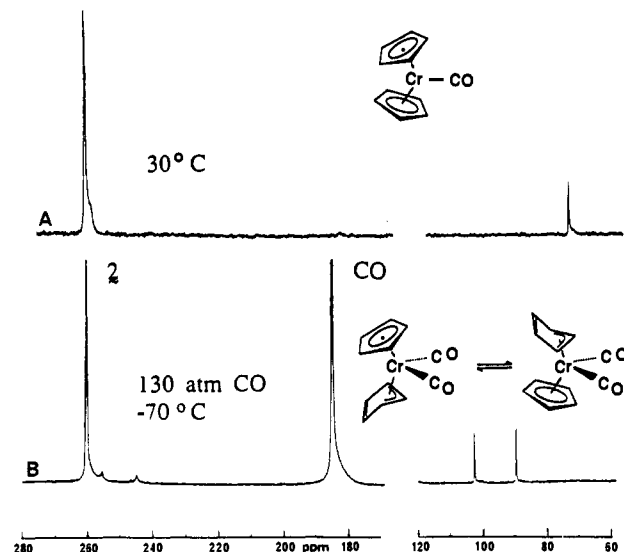

Figure 13. High-pressure ^{13}C NMR spectra of $(\eta^5\text{-C}_5\text{H}_5)_2\text{Cr(CO)}$ under ^{13}CO at 1.5 atm and 30 °C (A) and 130 atm and -70 °C (B).

TABLE I. Physical Parameters of Some Supercritical Fluids^a

fluid	T_c , °C	P_c , atm
CCl_2F_2	111.5	40.7
C_2H_4	9.9	50.5
C_2H_6	32.2	48.2
CO_2	31.0	72.9
N_2O	36.5	71.7

^aData taken from the *CRC Handbook of Chemistry and Physics*, 59 ed.; Weast, R. C., Ed.; CRC Press: West Palm Beach, FL, 1978.

rings since the intermediates in such a process would be stabilized by strong back-donation to the CO ligands.

C. Utilization of Supercritical Fluids

High-pressure NMR can be used in applications involving supercritical fluids. These fluids generally have viscosities 10 to 100 times lower than that of the normal liquid phase and self diffusion coefficients 10 to 100 times higher.⁵⁶ To the NMR spectroscopist, these properties are of significant benefit in studying quadrupolar nuclei, since the quadrupolar line width is proportional to the rotational correlation time.^{28,57,58} Carbon dioxide is probably the most commonly used supercritical phase, its critical temperature is 31.0 °C and its critical pressure is 72.9 atm, which is quite modest by high-pressure standards. Other common and easily accessible supercritical phases are listed in Table I.

1. Resolution Enhancement of Quadrupolar Nuclei

The utility of NMR studies of many quadrupolar nuclei have been somewhat limited, since quadrupolar relaxation can be very efficient, leading to broad lines and low sensitivity. In the extreme narrowing limit, the line width of these nuclei, $1/(\pi T_2)$ can be written

$$1/(\pi T_2) = \frac{3}{8}(e^2qQ/h)^2(1 + \eta^2/3)\tau \quad (8)$$

where e^2qQ/h is the quadrupolar coupling constant, τ is the rotational correlation time for the molecular motion, and η is the asymmetry parameter of the

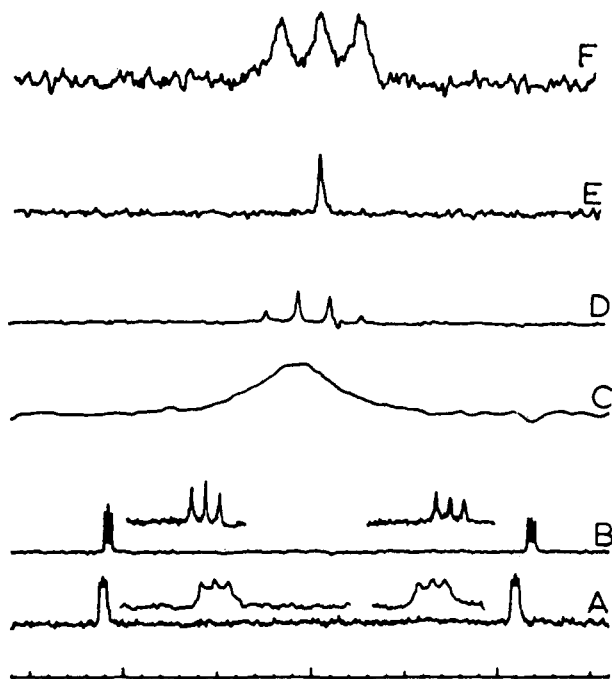

Figure 14. Natural abundance NMR spectra in supercritical and subcritical phases as described in text. All spectra are 800-Hz wide and each division is 25 Hz: (a) ^{14}N of hexane saturated with N_2O at 1 atm, 28 °C, (b) ^{14}N of supercritical N_2O at 40 °C, (c) ^{14}N of 7 M aqueous NH_3 , (d) ^{14}N of 0.5 M NH_3 in supercritical ethylene at 28 °C, (e) ^{17}O of subcritical CO_2 at 28 °C, (f) ^{17}O of subcritical nitrous oxide at 28 °C (reprinted from ref 57; copyright 1985 American Chemical Society).

electric field gradient tensor.^{59–61} From eq 8, one expects that decreasing the viscosity of a solvent should reduce τ and thus lead to narrower lines. The issue of how line width is affected by solvent viscosity and density is of paramount importance for the utility of supercritical fluids in NMR and much of the work to date has dealt with this matter.

Robert and Evilia have published a number of examples of the increase in resolution obtained with supercritical fluids and these are shown in Figure 14.⁵⁷ In Figure 14A, their ^{14}N spectrum of supercritical nitrous oxide shows line widths ranging from 0.6 to 1 Hz while line widths of nitrous oxide (Figure 14B) in "normal" phase hexane were about 6 Hz. Similarly, in Figure 14, parts D and C, ^{14}N spectra of NH_3 in supercritical nitrous oxide show 6-Hz line widths while that of NH_3 in water is about 150 Hz. Finally ^{17}O spectra of subcritical CO_2 and N_2O (Figure 14, parts E and F) show line widths of 1.9 and 11 Hz, respectively. Line widths in the supercritical phases agreed well in all cases with those predicted from experimentally measured T_1 's.

Jonas' group has shown line-narrowing factors ranging from 3 to 7 in ^{14}N , ^{33}S , and ^{55}Mn spectra using supercritical ethylene and CO_2 .⁶² However, this is much less than the estimate of 200 expected from the viscosity of the supercritical fluids at their critical point. At the fluid densities required to dissolve appreciable amounts of sample, the viscosity of the supercritical fluid is significantly increased from its value at the critical point and its efficacy for line narrowing is considerably reduced. This effect is illustrated by their ^{14}N spectra of 1,3,5-triazine. Jonas and co-workers measured a 145-Hz line width in acetone, however they obtained 40 Hz in relatively low density supercritical ethylene ($T = 75$ °C, $p = 114$ atm, $c = 0.2$ M) and 53 Hz at higher density

($T = 67$ °C, $p = 226$ atm, $c = 0.8$ M).

Robert and Evilia have noted that line widths are not simply proportional to viscosity but suggest the importance of a viscosity independent factor which plays a role in determining the rotational correlation time.²⁸ As an example they cite line widths of benzothiadiazole in supercritical ethylene,⁵⁸ which are not proportional to tabulated viscosities. Various studies have demonstrated the validity of the Stokes-Einstein-Debye equation⁶³

$$\tau = A\eta/T + \tau_0 \quad (9)$$

in which τ is the rotational correlation time, η is the solvent viscosity, T is the temperature, and τ_0 is the high temperature intercept. This equation predicts a linear relation between τ and η/T to a limiting value τ_0 attained in the limit as $\eta/T \rightarrow 0$. Comparison with eq 8 shows that NMR line widths should decrease with decreasing viscosity to a limiting value expected to be related to the free rotor correlation time given by

$$\tau_{\text{FR}} = (2\pi I/9kT)^{1/2} \quad (10)$$

where I is the moment of inertia about the rotational axis.⁶⁵

By combining NMR and light scattering data, Evilia et al. found nearly linear relations between τ and η/T in neat acetonitrile and benzonitrile even as η/T approached zero.⁶⁴ However in neat formamide they found that τ reached a limiting value at η/T equal to about 4×10^{-5} P/K, in agreement with eq 9.

2. Supercritical Fluid Chromatography Using NMR Detection

The high diffusion coefficients found in supercritical fluids allow high chromatographic separation efficiencies and their use in this area is reviewed elsewhere.^{56,65} Dorn's group has constructed an apparatus which uses ^1H NMR as a detector for supercritical fluid chromatography.⁶⁶ Their NMR detector consists of a flow-through NMR probe which allows continuous monitoring of a sample while in the supercritical phase (Figure 15). The active NMR sample volume is about 20 μL and published spectra required about 20 s each. They employed the apparatus to monitor model fuel mixtures and achieved greatly improved separation and identification of aliphatic components relative to that obtained with normal liquid-phase chromatography.

3. Homogeneous Catalysis in Supercritical Fluids

The cobalt-catalyzed hydroformylation of propylene in supercritical carbon dioxide was recently studied by Rathke, Klingler, and Krause using high pressure NMR.⁶⁷ Since only one phase is present in a supercritical media, the reaction was not affected by the usual liquid/gas mixing problems that can occur in conventional solvents. The rate of the reaction as well as the steady-state concentrations of catalytic intermediates were found to be very similar to values for other terminal olefins in nonpolar liquid media.

IV. Acknowledgment

We would like to acknowledge the continuous support and encouragement of Exxon Research and Engineering Company, as well as the contributions of our many

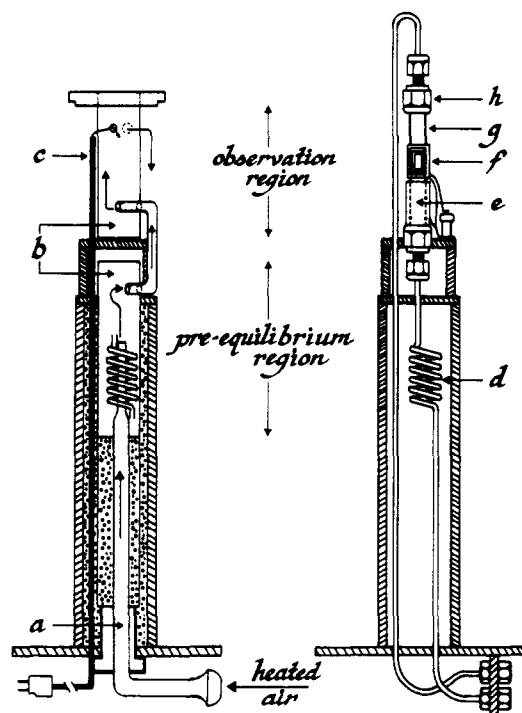

Figure 15. Custom flow probe for use in directly coupled SFC/NMR by Dorn: (a) insulated glass transfer line, (b) glass inserts, (c) Cu/constantan thermocouple, (d) stainless steel equilibration coil, (e) brass shield, (f) Helmholtz coil, (g) ceramic flow cell, (h) brass Swagelok fitting (reprinted from ref 66; copyright 1988 American Chemical Society).

collaborators at Exxon, Raymond A. Cook, Emilio C. Ponce, Dr. Suzanne Harris, Chuck K. Morgan, Alex J. Palmer, and the late Dr. Alexis A. Oswald. In addition we are pleased to thank our collaborators in academia, Professors Robert H. Crabtree, Carl D. Hoff, Maurice Brookhart, and Richard H. Fish. Finally, we would like to acknowledge the following for providing materials for the preparation of this article, Drs. Christopher D. Roe, William L. Earl, J. W. Rathke, Professors Allen D. King, Jr., Jiri Jonas, Brian T. Heaton, and Robert F. Evilia.

V. References

- Whyman, R. In *Laboratory Methods in Vibrational Spectroscopy*; Willis, H. A., Van der Mass, J. H., Miller, R. G. J., Eds.; Wiley: New York, 1987.
- (a) Jonas, J., Ed. *NMR Basic Principles and Progress*; Springer-Verlag: Berlin, 1991; Vol. 24 (*High Pressure NMR*). (b) van Eldik, R.; Jonas, J. *High Pressure Chemistry and Biochemistry*; Reidel: Dordrecht, 1987.
- Benedek, G. B.; Purcell, E. M. *J. Chem. Phys.* **1954**, *22*, 2003.
- Bridgman, P. W. *Physics of High Pressure*; Bell: London, 1958.
- Paul, W.; Benedek, G. B.; Warschauer, D. M. *Rev. Sci. Instrum.* **1959**, *30*, 874.
- Benedek, G. B. *Magnetic Resonance at High Pressure*; Interscience: New York, 1963.
- Jonas, J. *Rev. Sci. Instrum.* **1972**, *43*, 643.
- Oldenziels, J. G.; Trappeniers, N. *J. Physica* **1976**, *82A*, 565.
- Earl, W. L.; Vanni, H.; Merbach, A. E. *J. Magn. Res.* **1978**, *30*, 571.
- Ilgel, H.; van Jouanne, J. *J. Magn. Res.* **1984**, 506.
- Pisaniello, D. L.; Helm, L.; Meier, P.; Merbach, A. E. *J. Am. Chem. Soc.* **1983**, *105*, 4528.
- Heaton, B. T.; Jonas, J.; Eguchi, T.; Hoffman, G. A. *J. Chem. Soc., Chem. Commun.* **1981**, 331.
- Heaton, B. T.; Strona, L.; Jonas, J.; Eguchi, T.; Hoffman, G. A. *J. Chem. Soc., Dalton Trans.* **1982**, 1159.
- Vander Velde, D. G.; Jonas, J. *J. Magn. Res.* **1987**, *71*, 480.
- Hoffman, G. A. Ph.D. Thesis, University of Illinois, Urbana-Champaign, 1983 (University Microfilms, Ann Arbor, 1984).
- Rathke, J. W. *J. Magn. Res.* **1989**, *85*, 150.
- Gordon, S.; Dailey, B. P. *J. Chem. Phys.* **1961**, *34*, 1084.
- Raynes, W. T.; Buckingham, A. D.; Bernstein, H. J. *J. Chem. Phys.* **1962**, *36*, 3481.
- Jameson, A. K.; Jameson, C. J.; Gutowsky, H. S. *J. Chem. Phys.* **1970**, *53*, 2310.
- Jameson, C. J.; Jameson, A. K.; Cohen, S. M. *J. Chem. Phys.* **1973**, *59*, 4540.
- Coffin, V. L.; Brennen, W.; Wayland, B. B. *J. Am. Chem. Soc.* **1988**, *110*, 6063.
- Yamada, H. *Rev. Sci. Instrum.* **1974**, *45*, 640.
- Earl, W. L. Personal communication.
- (a) See acknowledgment in ref 25. (b) Nugara, N.; King, A. D., Jr. 40th Southeast Regional Meeting of ACS, Atlanta, GA, November 1988.
- Roe, D. C. *J. Magn. Res.* **1985**, *63*, 388.
- (a) Sapphicon Inc, Milford, NH 03055. (b) Aremco Products, Inc., Ossining, NY 10562.
- Horváth, I. T.; Ponce, E. C. *Rev. Sci. Instrum.* **1991**, *62*, 1104.
- Robert, J. M.; Evilia, R. F. *Anal. Chem.* **1988**, 2035.
- Mountvala, A. J.; Murray, G. T. *J. Am. Chem. Soc.* **1964**, *86*, 237.
- Roe, D. C. *Organometallics* **1987**, *6*, 942.
- (a) Vanni, H.; Earl, W. L.; Merbach, A. E. *J. Magn. Res.* **1987**, *29*, 11. (b) Kinrade, S. D.; Swadle, T. W. *J. Magn. Res.* **1988**, *77*, 569.
- (a) Parshall, G. W. *Homogeneous Catalysis*; Wiley: New York, 1980. (b) Collman, J. P.; Hegedus, L. S.; Norton, J. R.; Finke, R. G. *Principles and Applications of Organometallic Chemistry*; University Science Books: CA, 1987.
- James, E. R. *Homogeneous Hydrogenation*; Wiley: New York, 1973.
- Wender, I.; Pino, P. *Organic Synthesis via Metal Carbonyls*; Wiley: New York, 1968; Vol. 1; 1976; Vol. 2.
- Kubas, G. J. *Acc. Chem. Res.* **1988**, *21*, 120.
- Krusic, P. J.; Jones, D. J.; Roe, D. C. *Organometallics* **1986**, *5*, 456.
- Zoet, R.; Elsevier, C. J.; van Koten, G.; Versloot, P.; Vrieze, K.; van Wijnkoop, M.; Duineveld, C. A.; Goubitz, K.; Heijdenrijk, D.; Stam, C. H. *Organometallics* **1989**, *8*, 23.
- Cossee, P. *J. Catal.* **1964**, *3*, 80.
- Arlman, E. J. *J. Catal.* **1964**, *3*, 89.
- Arlman, E. J.; Cossee, P. *J. Catal.* **1964**, *3*, 99.
- Brookhart, M.; Volpe, A. F., Jr.; Lincoln, D. M.; Horváth, I. T.; Millar, J. M. *J. Am. Chem. Soc.* **1990**, *112*, 5634.
- Marder, T. B.; Roe, D. C.; Milstein, D. *Organometallics* **1988**, *7*, 1451.
- Shimokawa, S.; Yamada, E.; Makino, K. *Bull. Chem. Soc. Jpn.* **1983**, *56*, 412.
- Yokono, T.; Iyama, S.; Sanada, Y.; Shimokawa, S.; Yamada, E. *Fuel* **1986**, *65*, 1701.
- Horváth, I. T.; Siskin, M. *Energy Fuels*, in press.
- Crabtree, R. H. *Acc. Chem. Res.* **1990**, *23*, 95.
- Gonzalez, A. A.; Mukerjee, S. L.; Chou, S.-J.; Kai, Z.; Hoff, C. D. *J. Am. Chem. Soc.* **1988**, *110*, 4419.
- Millar, J. M.; Kastrup, R. J.; Melchior, M. T.; Horváth, I. T.; Hoff, C. D.; Crabtree, R. H. *J. Am. Chem. Soc.* **1990**, *112*, 9643.
- Falbe, J. *Carbon Monoxide in Organic Synthesis*; Springer-Verlag, 1970.
- (a) Pino, P. *Ann. N.Y. Acad. Sci.* **1983**, *415*, 111. (b) Sweany, R. L.; Russell, F. N. *Organometallics* **1988**, *7*, 719.
- Brown, D. T.; Eguchi, T.; Heaton, B. T.; Iggo, J. A.; Whyman, R. *J. Chem. Soc., Dalton Trans.* **1991**, 677.
- (a) Pruet, R. L. *Adv. Organometal. Chem.* **1979**, *17*, 1. (b) Gregorio, G.; Montrasi, G.; Tampieri, M.; Cavalieri d'Oro, P.; Pagani, G.; Andreatta, A. *Chim. Ind. (Milan)* **1980**, *62*, 389; 572. (c) Brown, J. M.; Canning, L. R.; Kent, A. G.; Sidebottom, P. *J. Chem. Soc., Chem. Commun.* **1982**, 721. (d) Brown, J. M.; Kent, A. G. *J. Chem. Soc., Chem. Commun.* **1982**, 723; *J. Chem. Soc., Perkin Trans. II* **1987**, 1597.
- (a) Oswald, A. A.; Merola, J. S.; Mozeleski, E. J.; Kastrup, R. V.; Reisch, J. C. *ACS Symp. Ser.* **1981**, *171*, 503. (b) Kastrup, R. V.; Merola, J. S.; Oswald, A. A. *ACS Symp. Ser.* **1982**, *196*, 43. (c) Oswald, A. A.; Hendriksen, D. E.; Kastrup, R. V.; Merola, J. S. *Preprints, Div. Pet. Chem., ACS*, **1982**, *27*, 292. (d) Horváth, I. T.; Kastrup, R. V.; Oswald, A. A.; Mozeleski, E. J. *Catal. Lett.* **1989**, *2*, 85.
- (a) Darensbourg, D. J.; Wiegrefte, H. P.; Wiegrefte, P. W. *J. Am. Chem. Soc.* **1990**, *112*, 9252. (b) Darensbourg, D. J.; Wiegrefte, P. W.; Riordan, C. G. *J. Am. Chem. Soc.* **1990**, *112*, 5759. (c) Darensbourg, D. J.; Mueller, B. L.; Bischoff, C. J.; Chojnacki, S. S.; Reibenspies, J. H. *Inorg. Chem.* **1991**, in press. (d) van Raaij, E. U.; Brintzinger, H. H. *J. Organomet. Chem.* **1988**, *356*, 315. (e) Millar, J. M.; Kastrup, R. V.; Harris, S.; Horváth, I. T. *Angew. Chem., Int. Ed. Engl.* **1990**, *29*, 194.
- Lee, M. L.; Markides, K. E., Eds. *Analytical Supercritical Fluid Chromatography and Extraction*; Chromatography Conferences, Inc.: Provo, 1990.
- Robert, J. M.; Evilia, R. F. *J. Am. Chem. Soc.* **1985**, *107*, 3733.

- (58) Lamb, D. M.; Vander Velde, D. G.; Jonas, J. J. *Magn. Res.* **1987**, *73*, 345.
- (59) Shaw, D. *Fourier Transform N.M.R. Spectroscopy*; Elsevier: Amsterdam, 1984.
- (60) Abragam, A. A. *The Principles of Nuclear Magnetism*; Oxford University Press: Oxford, 1961.
- (61) Spiess, H. W. In *NMR Basic Principles and Progress*; Diehl, P., Fluck, E., Kosfeld, R., Eds., Springer: Berlin, 1978; Vol. 15.
- (62) Lamb, D. M.; Adamy, S. T.; Woo, K. W.; Jonas, J. J. *Phys. Chem.* **1989**, *93*, 5002.
- (63) Berne, B. J.; Pecora, R. *Dynamic Light Scattering*; Wiley: New York, 1976.
- (64) Evilia, R. F.; Robert, J. M.; Whittenburg, S. L. *J. Phys. Chem.* **1989**, *93*, 6550.
- (65) Randall, L. G. *Sep. Sci. Technol.* **1982**, *17*, 1-118.
- (66) Allen, L. A.; Glass, T. E.; Dorn, H. C. *Anal. Chem.* **1988**, *60*, 390.
- (67) Rathke, J. W.; Klingler, R. J.; Krause, T. R. *Organometallics*, **1991**, *10*, 1350.