

2,4,6-Triphenylpyrylium Tetrafluoroborate as an Electron-Transfer Photosensitizer

Miguel A. Miranda* and Hermenegildo García

Departamento de Química/Instituto de Tecnología Química UPV-CSIC, Universidad Politécnica de Valencia, Apartado 22012, E-46071-Valencia, Spain

Received December 7, 1993 (Revised Manuscript Received March 11, 1994)

Contents

I. Introduction	1063
II. General Properties of TPT Relevant to Its Use as PET Sensitizer	1063
A. Light Absorption and Emission	1063
B. Thermodynamics and Kinetics of Electron Transfer	1065
C. Experimental Advantages	1066
D. Charge-Transfer Complexes	1067
E. Photolytic Generation of Pyranil Radicals	1068
F. Lack of Singlet Oxygen Formation	1068
G. Lack of Superoxide Formation	1068
H. Suitability To Study the Reactions of Organic Radical Cations with Molecular Oxygen	1069
I. Suitability To Study Effects of Spin Multiplicity on the Reactivity of Radical Ions	1069
III. PET Reactions Sensitized by TPT	1070
A. Cycloadditions	1070
B. $[2\pi + 2\pi]$ Dimerizations	1070
C. $[4\pi + 2\pi]$ Dimerizations	1072
D. $[4\pi + 2\pi]$ Cross Cycloadditions	1073
E. Cycloreversions	1074
F. <i>Z/E</i> Isomerization	1075
G. Sigmatropic Rearrangements	1077
H. Oxygenation/Dehydrogenation	1078
1. Oxygenation of Olefins	1078
2. α -Acetoxylation of Ketones via the Enol Acetates	1080
3. Dehydrogenations	1080
I. Fragmentations	1081
1. Carbon-Carbon Bonds	1081
2. Carbon-Oxygen Bonds	1083
3. Carbon-Nitrogen Bonds	1083
4. Carbon-Sulfur Bonds	1085
5. Carbon-Metal Bonds	1086
IV. Technical Applications of PET Reactions Sensitized by Pyrylium Salts	1087
V. Conclusion	1087
VI. Acknowledgments	1087
VII. References	1087

I. Introduction

Photoinduced-electron-transfer (PET) processes have attracted growing interest in the last decade.¹⁻⁹ This has led to a better understanding of the involved mechanisms and to the development of new synthetic methodologies. In particular, PET reactions such as

cycloadditions, cycloreversions, oxygenations, and fragmentations have been extensively documented.

When designing a PET experiment, a key point is selection of the sensitizer. In principle, many molecules are potentially useful for this purpose, but only a few have found application in practice. Cyanoaromatic compounds constitute at the present moment the most important group of PET sensitizers.

2,4,6-Triphenylpyrylium tetrafluoroborate (TPT) absorbs in the visible and is a good oxidizing agent in the excited state. It is easily accessible and highly soluble in organic solvents. Since it is a salt, there is no net charge separation associated to the electron-transfer step. Therefore the formation of free-radical ions is enhanced, while deactivation through back-electron transfer (BET) is reduced, in comparison with cyanoaromatics. Besides, TPT is also an efficient PET sensitizer in its triplet excited state. This allows generation of triplet radical ion pairs and thus examination the effect of spin multiplicity on the fate of these intermediates. In the field of electron-transfer photooxygenation, a unique property of TPT is that it produces neither singlet oxygen nor superoxide radical anions. Thus, TPT is a suitable photosensitizer to study the reactions of organic radical cations with molecular oxygen.

The present review covers the literature appearing from the early 1960s through mid-1993. In the first section, the general properties of TPT relevant to its use as a PET sensitizer are conveniently summarized. The body of the article is devoted to showing the wide applicability of this salt in promoting a variety of specific chemical transformations. Where data are available, the behavior of TPT is compared with that of other electron-transfer photosensitizers, including pyrylium salts with different counterions and/or different substituents at the heterocyclic ring, as well as cyanoaromatics. The observed similarities and differences are clearly indicated and, if possible, justified. Finally, there is a short section devoted to the phototechnological applications of pyrylium salts, which provides key entries to the patent literature for the interested readers.

II. General Properties of TPT Relevant to Its Use as PET Sensitizer

A. Light Absorption and Emission

A summary of the main physicochemical parameters of the 2,4,6-triphenylpyrylium cation (TP^+) relevant to its use in photochemical electron-transfer processes are contained in Scheme 1 and Figures 1-3.



Miguel A. Miranda was born in Albacete, Spain, in 1952. He studied chemistry at the Universidad de Valencia (1968–1974) and received his Ph.D. at the Universidad Autónoma de Madrid, in 1978. The experimental work was done with R. Martínez-Utrilla, in the field of preparative organic photochemistry, at the Organic Chemistry Institute of the C.S.I.C. After a one-year postdoctoral stay with H. Dürr in Saarbrücken, Germany, working on the synthesis of spiroconjugated hydrocarbons, he joined the faculty of the Organic Chemistry Department (Faculty of Pharmacy) at the Universidad de Valencia. From 1979 to 1989 he worked at this institution, where he became associate professor in 1985. During this period, he spent one year (1986–1987) as an A. v. Humboldt postdoctoral fellow at the University of Würzburg (Germany), working with W. Adam on radical cations of azo compounds. In 1990 he assumed his present position of full professor at the Universidad Politécnica de Valencia. His current research field is organic photochemistry, with special emphasis on photochemical electron transfer, photoreactions inside zeolites and the photochemical bases of photosensitization by drugs or other chemicals. M. A. Miranda has written about 100 articles on these subjects in international journals, as well as a number of reviews and book chapters.



Hermenegildo García was born in 1957 in Canals, Spain. He graduated with honors from the Universidad de Valencia, where he received his Ph.D. in 1983 under the supervision of M. A. Miranda. In 1983 he joined the Chemistry Department of the Universidad Politécnica de Valencia, where he is currently an Associate Professor. H. García has been a postdoctoral research fellow at the University of Reading, UK (A. Gilbert) and at the University of Ottawa, Canada (J. C. Scaiano). His research interests include organic photochemistry within zeolites and the use of carbenium ions as photosensitizers. On these and related subjects he has written over 50 scientific articles.

When using a photosensitizer, one of the most important characteristics to ensure its general applicability is the UV–vis *absorption* spectrum. Ideally, the spectrum must have strong bands at long wavelengths in the visible to allow selective excitation of the photosensitizer in the presence of a large variety of chromophores. Systematic studies on a large series of pyrylium salts can be found in the literature.^{10–13}

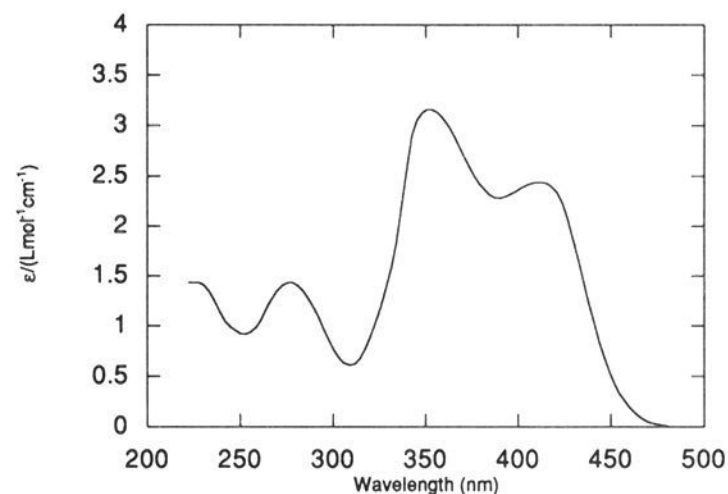
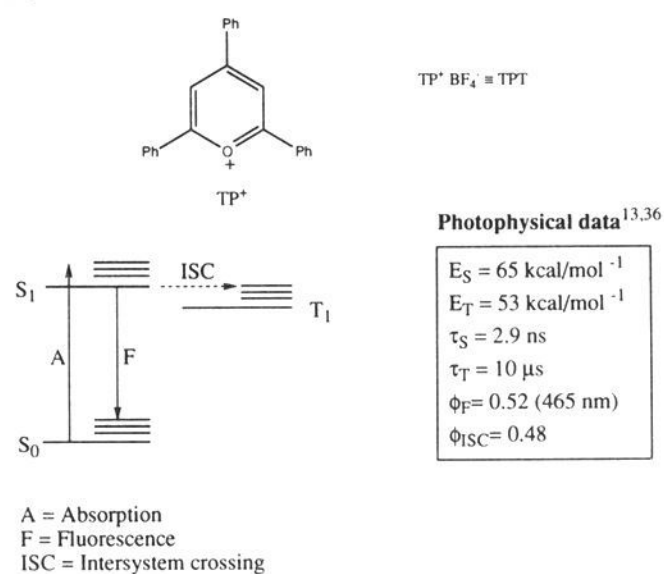

Figure 1. UV–vis absorption spectrum of TPT in CH_2Cl_2 . (Adapted from ref 13.)

Scheme 1



Particularly, TPT exhibits two absorptions in CH_2Cl_2 at 417 and 369 nm with extinction coefficients around 29 500 and 42 500 $\text{dm}^3 \text{mol}^{-1} \text{cm}^{-1}$, respectively (Figure 1). According to the different charge distributions involved in the transition from the ground solvated state to the excited unsolvated state, increasing solvent polarity results in a hypsochromic shift of the absorption maxima to shorter wavelengths. They have been ascribed as due to two independent chromophores: the 2,6-diarylpyrylium substructure (longer wavelength) and the 4-arylpyrylium moiety (shorter wavelength). Depending on the UV spectrum of the PET-reaction partners, the TPT absorption band in the visible enables one to use a variety of glasses (Corning O-51, Oriel 5146 long pass filter, Toshiba UVD-35, or even Pyrex), as well as solutions (K_2CrO_4 in aqueous Na_2CO_3 or mixtures of CuSO_4 and NaNO_2 in aqueous NH_3), to cut off the undesired emission of conventional mercury lamps, thus avoiding direct photolysis of the substrates.¹⁴

Pyrylium salts have also characteristic *emission* spectra. Both fluorescence and phosphorescence can be generally observed.^{13,15–17} The strong bathochromic shift of the fluorescence (up to 70 nm) with the decreasing temperature has been rationalized as a reflection of the dramatic changes in solvation, reorganization, and relaxation of the solvent molecules due to modification of the charge distribution during electronic excitation. It is interesting to note that in contrast to the relatively high intersystem crossing efficiency of TPT, the fluorescence quantum yield of other 2,4,6-triarylpyrylium cations can be almost unity, especially for aromatic rings bearing methoxy sub-

Table 1. Spectroscopic and Photophysical Data of TPT and Other Related Pyrylium Cations^{13,16,31}

R ²	R ⁴	R ⁶	λ _A ^{max} (nm)	λ _F ^{max} (nm)	φ _F	τ _g (ns)
Ph	Ph	Ph	417, 369	465	0.52	2.9
Ph	H	Ph	417	463	0.84	3.7
<i>p</i> -CH ₃ OC ₆ H ₄	<i>p</i> -CH ₃ OC ₆ H ₄	<i>p</i> -CH ₃ OC ₆ H ₄	426, 455 sh	529	0.95	4.0
<i>p</i> -CH ₃ OC ₆ H ₄	Ph	Ph	464, 371	538	0.84	7.2
Ph	<i>p</i> -C ₆ H ₄ OCH ₃	Ph	432	511	0.28	4.7
<i>p</i> -CH ₃ OC ₆ H ₄	H	<i>p</i> -CH ₃ OC ₆ H ₄	488	536	0.91	3.9
Ph	COOEt	Ph	436, 325	514	0.47	5.9
<i>p</i> -(CH ₃) ₂ NC ₆ H ₄	Ph	Ph	577, 359	625	0.006	—
Ph	CH ₃	Ph	387	451	0.51	3.7
<i>p</i> -BrC ₆ H ₄	Ph	Ph	412, 359	485	0.28	2.1

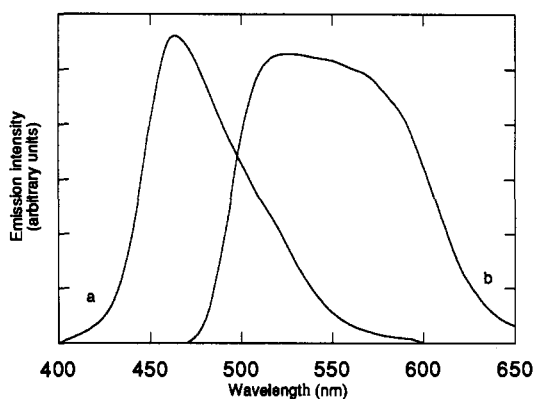

Figure 2. Emission spectra of TP⁺ClO₄⁻: (a) fluorescence at room temperature, and (b) phosphorescence at 77 K. (Adapted from ref 16.)

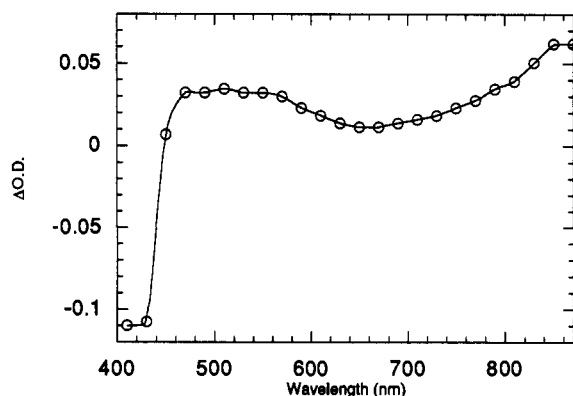

Figure 3. Transient absorption of TP⁺ClO₄⁻ in CH₂Cl₂ solution 4 μs after 347-nm laser excitation. (Adapted from ref 23.)

stituents or other groups of medium donor strength. In fact, the strong fluorescence emission of some pyrylium cations is responsible for their excellent lasing properties that would make possible their use as Q-switches for ruby lasers.¹⁸ Furthermore, they can exhibit an efficiency similar to that of Rhodamine 6G in dye lasers but expanding to an even wider range of tunable wavelengths.^{19–22} In those cases, the phosphorescence is absent or remains under the detection limits of the instrument. The main data concerning the absorption and emission properties and other photophysical characteristics of TPT and other related pyrylium salts are contained in Table 1 and Figure 2. The transient T–T absorption of the TP⁺ClO₄⁻ triplet state²³ is presented in Figure 3.

B. Thermodynamics and Kinetics of Electron Transfer

The *reduction potential* of pyrylium cations has been measured by cyclic voltammetry, second harmonic ac voltammetry, and polarographic methods.^{24–26} It has been found that TPT is not a good oxidizing agent in the ground state. However, during the experimental determination of homolytic and heterolytic C–C, C–O, and C–S bond dissociation energies by calorimetric measurements of the reaction between TP⁺ and fluorinides,²⁵ phenoxides,²⁷ and thiophenoxides,²⁸ some spontaneous electron-transfer processes in the ground state with negative free energy changes have been established (Table 2). On the other hand, the reversion of electrogenerated pyranil radicals to their corresponding pyrylium cations, coupled with the reduction of polycyclic aromatic hydrocarbon radical cations to their neutral molecules has allowed the generation of excited arene triplets and subsequent luminescence measurements without a previous photochemical excitation^{29,30} (Scheme 2).

Scheme 2

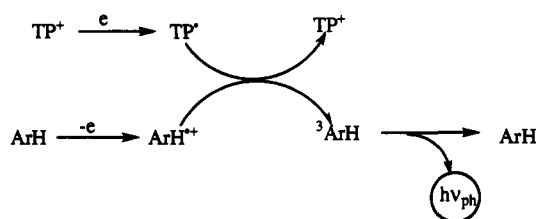

The poor performance of TPT as electron acceptor in the ground state sharply contrasts with the exceedingly strong oxidizing power of TPT excited states^{31,32} as evidenced by its reduction potential calculated by applying the Rehm–Weller equation.³³ An energy diagram outlining the different balances between the transfer of one electron from a donor (D) to the ground or excited state of TPT is presented in Scheme 3.

When using this equation, two peculiarities of TPT have to be considered. Firstly, it has been found that excited TPT can act as *electron acceptor from the singlet and the triplet excited states*. Since both states have different excitation energies, it follows that TPT must exhibit two different reduction potentials depending on the spin multiplicity involved in the reaction mechanism. These high values compare favorably with the reduction potentials of other widely used PET

Table 2. Heterolytic (ΔH_1) and Homolytic (ΔH_2) Bond Dissociation Energies and Enthalpy Changes for the Ground-State ET between TP⁺ and Some Fluorenides, Phenoxides, and Thiophenoxides^{25,27,28}

A ⁻	$-\Delta H_1$ (kcal/mol)	$-\Delta H_2$ (kcal/mol)	ΔH_{ET} ($\approx \Delta G_{ET}$) (kcal/mol)
9-phenylfluorenide	21.73 ± 0.4	14.10	-7.63
9-phenylthiofluorenide	18.02 ± 0.45	15.44	-2.58
9-carbomethoxyfluorenide	9.03 ± 0.30	13.99	4.96
4-chlorophenoxide	9.21 ± 0.22	24.29 ± 0.47	15.08 ± 0.42
4-fluorophenoxide	12.86 ± 0.17	23.84 ± 0.33	10.98 ± 0.28
4- <i>tert</i> -butylphenoxide	13.57 ± 0.68	21.96 ± 0.77	8.39 ± 0.36
thiophenoxide	9.05	16.87 ± 0.23	7.82 ± 0.20
4-methylthiophenoxide	10.45 ± 0.44	16.79 ± 0.46	6.34 ± 0.20
4-methoxythiophenoxide	11.47 ± 0.63	16.77 ± 0.66	5.30 ± 0.19

Scheme 3

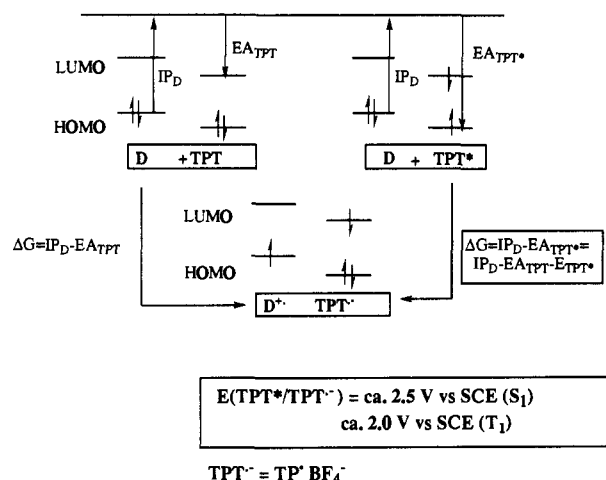

sensitizers, for instance cyanoaromatics. Thus, the number of substrates capable of acting as possible electron donors is enlarged. The second point to be remarked is the negligible contribution of the Coulombic term to the total free energy change of the ET process, which is a direct consequence of the *lack of net charge separation*. As the pyrylium ring bears a positive charge, only charge exchange takes place when the radical cation of the donor is generated (Scheme 4). In

Scheme 4

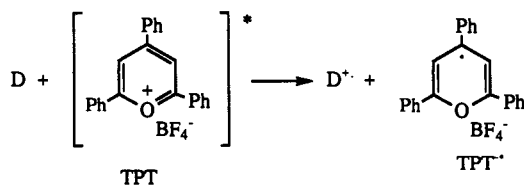

this context, it has been found that the PET efficiency is generally higher for cationic sensitizers than for neutral sensitizers.³⁴ It has been reasoned that diffusion and escape to give free radical ions is enhanced by the lack of Coulombic attraction between the donor-acceptor (D-A) partners. Therefore, this factor reduces back-electron transfer (BET) within the contact pairs, which is the main pathway leading to deactivation of the photogenerated radical cations.

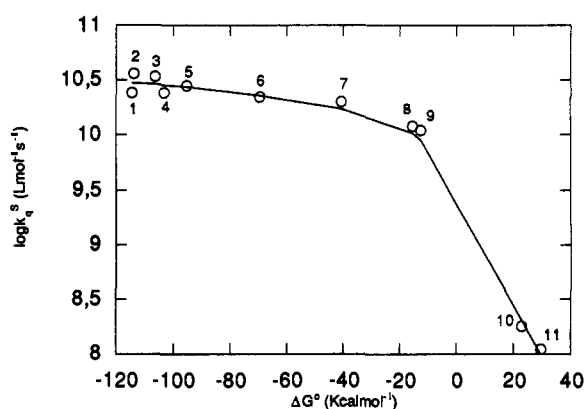

Figure 4. Plot of the logarithm of the rate constant for fluorescence quenching *vs* the free-energy changes associated with the PET from donors to the singlet excited state of TPT: (1) tetraphenylethylene, (2) 1,4-dimethoxybenzene, (3) *trans*-stilbene, (4) adamantylideneadamantane, (5) triphenylethylene, (6) biphenyl, (7) mesitylene, (8) 4-chlorotoluene, (9) toluene, (10) chlorobenzene, (11) benzene. (Adapted from ref 36.)

Concerning the *kinetics* of PET reactions sensitized by TPT, it has been observed that the fluorescence quenching rate increases as the free energy changes of the electron transfer become more negative^{35,36} (Figure 4). For practical purposes, it can be considered that the quenching is diffusion controlled when ΔG is less than $-10 \text{ kcal mol}^{-1}$. These experimental observations are in good agreement with the general relationship between the ET driving force and the free energy of activation for the "normal region", as predicted by the Marcus theory.³⁷

C. Experimental Advantages

Besides fulfilling the requirements of selectivity in the excitation and high oxidizing power, TPT gathers other important *experimental advantages* that make this compound one of the most convenient PET sensitizers. Thus, TPT is commercially available from some of the largest chemical suppliers and can be readily prepared by condensation of chalcone with acetophenone using hydrotetrafluoroboric acid³⁸ or directly in one step from acetophenone and benzaldehyde, using boron trifluoride. Likewise, the use of other Brønsted

acids, like HClO_4 or even HOAc , as well as anion exchange gives access to other analogues. The synthesis and chemical behavior of pyrylium salts have been comprehensively reviewed elsewhere.^{11,39,40} Moreover, TPT is highly soluble in some common organic solvents, and the photosensitization can be carried out adequately in dichloromethane or acetonitrile. After the photochemical reaction, the ionic nature of TPT allows its easy chromatographic separation from the reaction mixtures. The combination of all these characteristics makes TPT an experimentally friendly sensitizer.

However, it must be mentioned that the high oxidation power of TPT is not always convenient, as in certain cases the selectivity might be lost.³¹ Thus, the analogous tris(4-methoxyphenyl)pyrylium tetrafluoroborate, with a lower oxidation power in its excited state, leads sometimes to better results. On the other hand, TPT and related pyrylium salts possess a strong Lewis acidity which can complicate the electron-transfer reactivity and can give rise to undesired side reactions.³¹

Although TPT can be handled without any special precaution, it has to be emphasized that the perchlorate salt of TP^+ can explode under extreme conditions of heating.⁴¹ Consequently, the storage and use of large amounts of this sensitizer is to be avoided.

D. Charge-Transfer Complexes

The electron acceptor ability of pyrylium cations, both in the ground and excited states, is responsible for the formation of charge-transfer (CT) complexes, an intermediate situation previous to the complete transfer of one electron. However, owing to the high reactivity of pyrylium toward nucleophiles, the nature of the CT complexes that can be formed is severely limited to those electron donors not yielding nucleophilic ring-opening products. In particular, the use of primary amines can be complicated by the formation of pyridinium heterocycles, whereas secondary or tertiary amines can yield addition-elimination products.¹¹

The formation of CT complexes between phenyl-substituted pyrylium salts and a series of polycyclic condensed arenes and substituted benzenoid compounds has been studied.^{35,42} In those cases where a well-defined new absorption band due to the CT complexes could be resolved, a good correlation between the energy of the absorption maximum and the oxidation half-wave potential of the donors was established. Likewise, a linear relationship between the energy of the CT band maximum with anthracene and the reduction potential of the corresponding pyrylium cation was obtained (Figure 5). The one-to-one stoichiometry of the CT complexes and their association constants were determined by plotting the optical densities of the CT band against the concentration of the donor.

The emissive properties of pyrylium CT complexes with naphthalene and pyrene have been also studied^{43,44} (Figure 6). Selective excitation at low temperature of one of the partners of the CT complex gave the characteristic emission from this excited partner. Besides, a new weaker fluorescence (mirror image of the CT absorption) was detected. Its intensity increased significantly upon excitation of the characteristic CT band.⁴⁴ Even specific structureless phosphorescence at wavelengths longer than those due to either

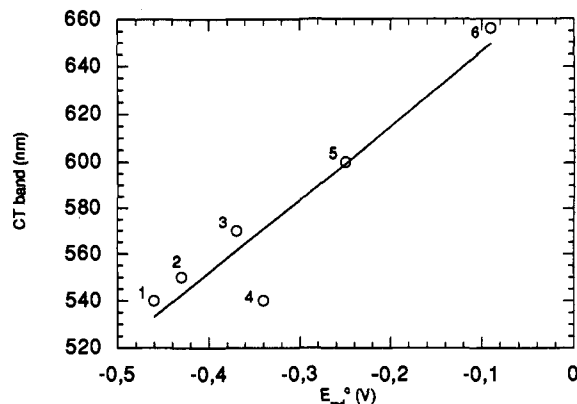

Figure 5. Linear relationship between the wavelength of the CT band maximum (anthracene as donor) and the reduction potential for a series of pyrylium cations with the following substitution: (1) 2,4-diphenyl-6-methyl, (2) 2,3,4,6-tetraphenyl, (3) 2,4,6-triphenyl, (4) 2,6-diphenyl, (5) 4-phenyl-2,3,5,6-dinaphthalene-1,8-diyl, (6) 2,6-diphenyl-4-ethoxycarbonyl. (Adapted from ref 35.)

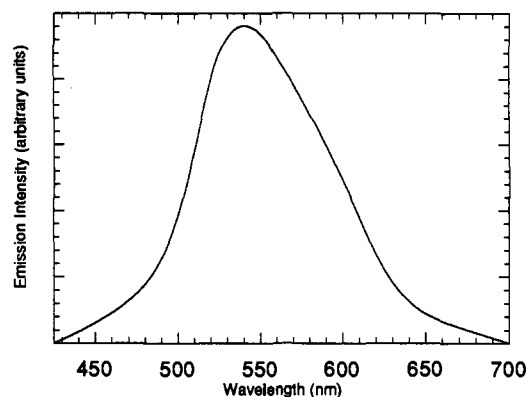
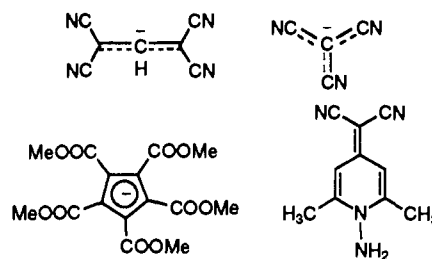

Figure 6. Fluorescence due to the specific emission of the CT complex between $\text{TP}^+\text{ClO}_4^-$ and naphthalene at 77 K after 500-nm selected excitation of the CT band. (Adapted from ref 44.)

the pyrylium or the donor (attributable to the CT) has been observed.

In a very few cases, these CT complexes have been isolated in a crystalline form. This is the case for the TP^+ salts with anions like 1,1,3,3-tetracyanopropenide and tricyanomethanide⁴⁵ or 1,2,3,4,5-pentacarbomethoxycyclopentadienide⁴⁶ or with neutral basic molecules like *N*-amino-4-(dicyanomethylene)-2,6-dimethyl-1,4-dihydropyridine⁴⁷ (Chart 1).

Chart 1



Pyrylium iodides can also be included in this category. The red shift of the absorption spectrum of pyrylium iodides compared with other salts has been attributed to the formation of a true CT complex.⁴⁸⁻⁵⁰ The same applies for the thiocyanates and selenocyanates.⁵⁰ In general, pyranil radicals can be detected in the solutions

of pyrylium halides in nonpolar solvents, but they are not formed using polar solvents.⁵¹ This behavior can be easily interpreted in terms of the predominance of intimate contact ion pairs in apolar solvents or solvated free pyrylium and halide ions in polar media.

E. Photolytic Generation of Pyranyl Radicals

There is plenty of information about the generation and spectroscopic characterization of pyranyl radicals from the corresponding pyrylium cations after chemical⁵²⁻⁵⁶ or electrochemical⁵⁷⁻⁶⁰ single-electron reduction. Dimerization is the major pathway undergone by these radicals. However, this is a reversible reaction: aryl substitution at the 4-position of the pyrylium ring and higher temperatures shift the equilibrium to the pyranyl radical.

2,4,6-Triphenylpyranyl (TP[•]) and other related 4-substituted radicals can also be generated by mere irradiation of TPT in degassed THF or 1,2-dimethoxyethane, by electron transfer from the solvent, with relatively high quantum yields^{61,62} (Scheme 5). This

Scheme 5

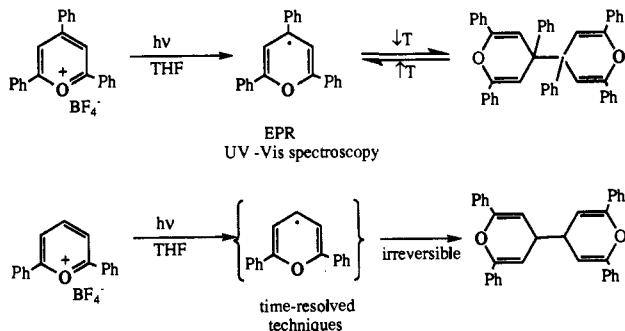

points out the excellent aptitude of excited TPT to accept one electron. TP[•] was identified by the electronic absorption (Figure 7) and the EPR spectra. Furthermore, the resolved EPR hyperfine structure observed at room temperature was in good agreement with that predicted by simulation. With decreasing temperature, the characteristic light red color of TP[•] in THF faded, while the intensity of the EPR signal decreased, indicating formation of the diamagnetic dimers. In the case of 4-aryl-substituted pyrylium ions, this process has been found to be reversible, as evidenced by the recovery of the original EPR intensity by warming up to room temperature. The enthalpies of dissociation of a series of pyranyl dimers could be established in this way. No radicals were detected when the photolyses were carried out in acetonitrile, which is in agreement with the better electron donor ability of THF and ethers in general.

Analogous photolysis in THF of 2,6-diphenylpyrylium tetrafluoroborate, in which substituents at the 4-position of the heterocyclic ring are lacking, gave irreversibly the corresponding 2,2',6,6'-tetraphenyl-substituted dimer. Evidence for the pyranyl radical could only be obtained using time-resolved spectroscopy.⁶³

Likewise, when using TPT as photosensitizer in the presence of electron donors, a second piece of evidence for the operation of a PET mechanism has been received by the detection in some cases of TP[•] using time-resolved techniques.

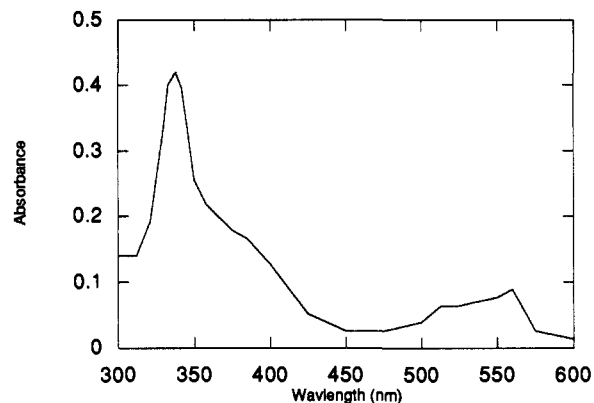

Figure 7. Absorption spectrum of TP[•] recorded upon irradiation of TP⁺ in THF. (Adapted from ref 61.)

F. Lack of Singlet Oxygen Formation

TPT is not able to participate in energy transfer from its excited triplet state to ground-state oxygen, at least under the usual photooxygenation conditions.^{36,64}

Laser flash photolysis (LFP) of TPT (1.6×10^{-4} M) under argon gave a transient spectrum assigned to the T-T absorption of TPT (very broad band with a maximum at ca. 850 nm). Accordingly, it was efficiently quenched by dissolved oxygen with $k_q[\text{O}_2] = 1.3 \times 10^6 \text{ s}^{-1}$. On the other hand, LFP of TPT (ca. 10^{-4} M) under argon, in the presence of different electron donors (1.4×10^{-4} M), where quenching of the excited singlet state was not significant, gave transient spectra assigned to the pyranyl radical. The quenching rate constants (k_q^T) were in all cases ca. $10^{10} \text{ dm}^3 \text{ mol}^{-1} \text{ s}^{-1}$ (diffusion controlled), in agreement with the fact that the free-energy changes were negative enough in the normal Marcus region. Under the preparative oxygenation conditions, the donors used are present in higher concentrations (10^{-2} – 10^{-1} M) and hence triplet TPT must be quenched more than 100 times more rapidly by the donors than by dissolved oxygen.^{36,64}

G. Lack of Superoxide Formation

Very usually, after the electron-transfer step leading to formation of donor/acceptor radical ion pairs, the reduced species interacts with molecular oxygen, affording the superoxide radical anion. The latter may play a key role in electron-transfer photooxygenation, reacting with the oxidized form of the donor (Scheme 6).

Scheme 6

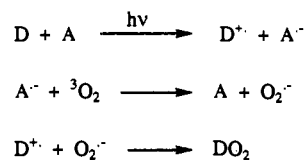

In the case of TPT, this is not possible because of thermodynamic reasons. Taking into account the known reduction potentials of TPT and oxygen, the calculated ΔG is $+11.3 \text{ kcal mol}^{-1}$, if the Coulombic factor associated to charge separation is neglected (Scheme 7).

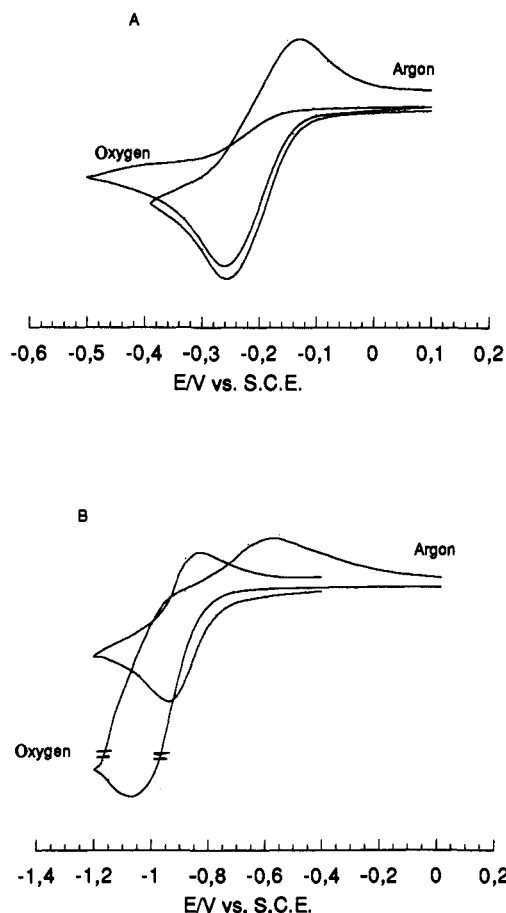
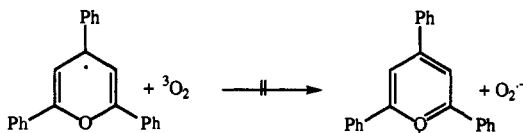

Figure 8. Cyclic voltammograms, recorded in the absence and presence of oxygen, of TPT (1.5×10^{-3} M) in CH_2Cl_2 (A) and 9,10-dicyanoanthracene (2.0×10^{-4} M) in MeCN (B). (Adapted from refs 36 and 64.)

Scheme 7



This was confirmed by laser flash photolysis experiments, which showed no influence of oxygen on the transient spectra of the pyryl radical generated by quenching of excited TPT (singlet or triplet) by several donors.^{36,64}

In the comparative study of TPT and DCA by cyclic voltammetry (Figure 8), the following facts were observed: (a) both photosensitizers exhibited reversible behavior under inert atmosphere, (b) TPT displayed typical EC voltammograms in the presence of oxygen, indicating that the pyryl radical reacts with molecular oxygen, (c) the heights of the reduction current in the presence and absence of oxygen were markedly similar, suggesting that the resulting peroxy radical is electrochemically inactive, and (d) in the presence of oxygen, the reduction of DCA showed a huge current increase, consistent with a mechanism in which $\text{DCA}^{\cdot-}$ reduces molecular oxygen to superoxide, repeating this cycle until oxygen is consumed near the electrode.^{36,64}

The above observations were found to be consistent with the lack of superoxide generation in the TPT-photosensitized reactions and with the trapping of TP^{\cdot} by molecular oxygen (Scheme 8).

Scheme 8

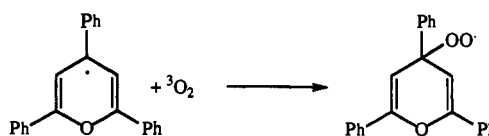

The latter process was detected in the electrochemical time scale (seconds), but not in the laser flash photolysis time scale (microseconds).

H. Suitability To Study the Reactions of Organic Radical Cations with Molecular Oxygen

A common problem in the photooxygenation of olefins or other organic molecules is the involvement of several oxygen-derived species (molecular oxygen, singlet oxygen, superoxide radical anion) and the contribution of different reaction pathways to the formation of the final products. Hence, it is highly desirable to find "clean" photosensitizers, which operate by a single mechanism. In this context, TPT provides a powerful tool to elucidate the reactivity of radical cations with molecular oxygen, in view of the fact that it produces neither singlet oxygen nor superoxide upon photochemical excitation (see above).^{36,65} The sequence of steps actually intervening are those of a chain reaction (Scheme 9):

Scheme 9

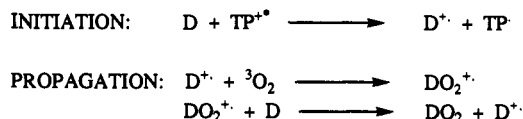

Specific examples of such processes are presented in section III.H.

I. Suitability To Study Effects of Spin Multiplicity on the Reactivity of Radical Ions

It has been mentioned that the quantum yield of fluorescence and intersystem crossing are comparable in the case of TPT. When electron donors are present at high concentrations (for instance, 10^{-1} M), most of the excited TPT singlets are quenched. Conversely, at lower donor concentrations (typically 10^{-4} M) singlet quenching is negligible and triplet TPT becomes the predominant electron acceptor species. Formation of the pyryl radical (indicative of the electron-transfer process) has been observed by laser flash photolysis under both sets of conditions (see section II.E). In this way, singlet or triplet radical ion pairs can be generated in the TPT-photosensitized reactions (Scheme 10).⁶⁵⁻⁶⁷

Scheme 10

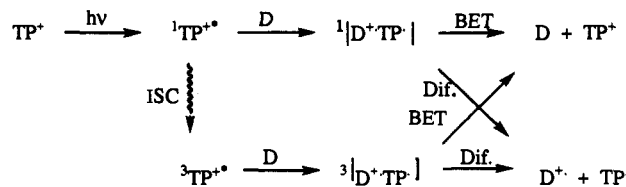

The triplet pairs appear to be more efficient in the generation of free radical ions, owing to the lower extent of back-electron transfer as compared with the singlet analogues. Further effects of spin multiplicity on the

reactivity of radical ion pairs constitute an interesting field for future investigations.

III. PET Reactions Sensitized by TPT

A. Cycloadditions

The general current paradigm for the TPT-sensitized photocycloadditions of alkenes and dienes is presented in Scheme 11. It consists of a chain mechanism that

Scheme 11

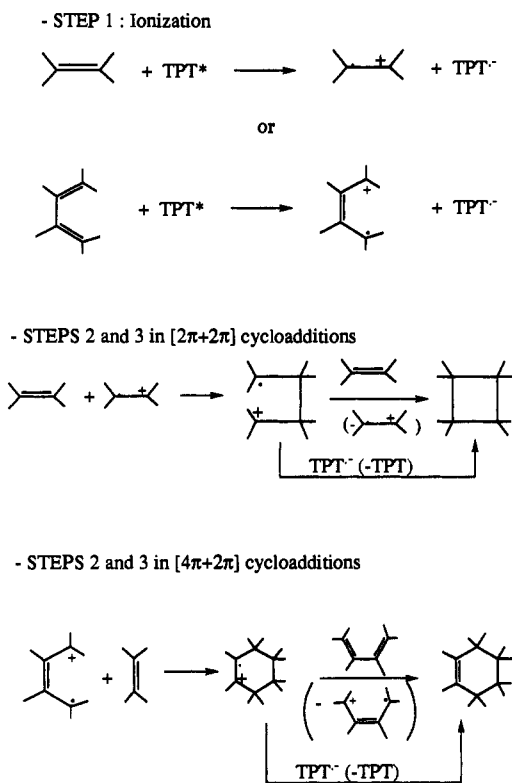

only requires catalytic amounts of pyrylium salt. Thus after light absorption, TPT in its singlet or triplet excited state accepts an electron from the electron-rich C=C double bond to generate pyranil radical and the radical cation of the olefin. Addition of the latter species to another molecule of alkene or diene gives rise to the radical cation of the corresponding $[2 + 2]$ or $[4 + 2]$ cycloadduct. Owing to the higher oxidation potential of these secondary intermediates, the final step of the chain is usually an electron transfer to form the neutral cycloadduct and a secondary nonphotochemically generated alkene radical cation. This mechanism explains why the quantum yield of product formation can be higher than unity.

B. $[2\pi + 2\pi]$ Dimerizations

TPT-sensitized irradiation of indene and 1,1-dimethylindene ($E_{D^{\bullet+}/D} = 1.68$ V vs SCE) in acetonitrile gave rise exclusively to the corresponding head-to-head dimers in a 97% *anti* stereoselectivity⁶⁸ (Scheme 12). This result contrasts with the poor regioselectivity achieved in the triplet state dimerization, where appreciable amounts of the head-to-tail dimers are also formed. Moreover, the possibility that an energy-transfer mechanism could be operating was conclusively

Scheme 12

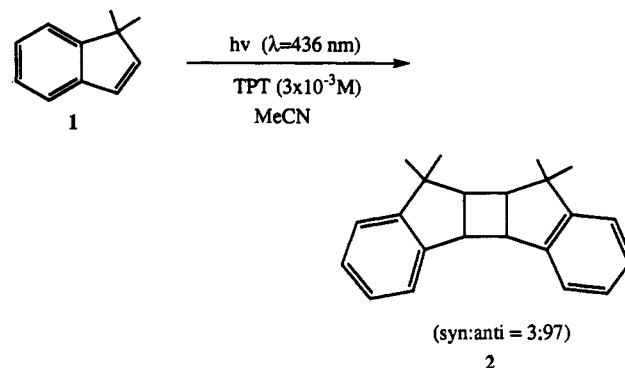

ruled out taking into account that the triplet state of TPT ($E_T = 53$ kcal/mol) lies far below those of the indenenes (*ca.* 60 kcal/mol) and that the outcome of the TPT-sensitized dimerization was unaffected by triplet quenchers. On the other hand, quenchers with low oxidation potential such as 1,2,4-trimethoxybenzene ($E_{D^{\bullet+}/D} = 1.12$ V vs SCE) efficiently suppressed the dimerization. However, the fact that the quantum yield was enhanced by the presence of oxygen still remains unexplained.

According to the general mechanism accepted for the TPT-photosensitized cycloadditions (Scheme 11), the stereochemistry of indene dimerization is readily explained in terms of addition of the indene radical cation to another neutral molecule, to give the highly stabilized head-to-head distonic 1,4-radical cation.

Likewise, it has been reported that the TPT-sensitized irradiation of phenyl vinyl ether in acetonitrile gives rise mainly to the *cis* and *trans* stereoisomers of 1,2-diphenoxycyclobutane (Scheme 13). However, in this case formation of phenol and 2-methyl-3-phenoxypyridine as byproducts in equimolar amounts was also observed. These unexpected products have been explained as arising from trapping of the dimeric 1,4-radical cation 4 by the solvent.

Dimerization of phenyl vinyl ether has also been carried out using two polymer-bound 2,4,6-triaryl-substituted pyrylium cations. The obtention of these polymeric sensitizers is outlined in Scheme 14. This was the first attempt to obtain a pyrylium-based heterogeneous sensitizer. However, it was found that the efficiency of the heterocyclic centers to induce the photosensitized dimerization of phenyl vinyl ether was drastically diminished by the polymer backbone.^{32,69} A different approach to prepare this type of polymer-bound pyrylium salts, based on the attack of a metalated polystyrene to the 4-position of 2,6-diphenylpyrylium, followed by a final oxidation of the pyranil-substituted polystyrene with trityl perchlorate, can also be found in the literature.⁷⁰

Although the dimerization of *trans*-stilbene (TS) has not been observed at a preparative scale, laser flash photolysis studies have allowed one to detect dimeric radical cations of TS as transient species.⁷¹ Thus, upon 408-nm excitation of a dichloromethane solution of TPT containing TS (4.7×10^{-4} M), TP^{\bullet} characterized by a weak absorption maximum at 550 nm was formed, together with another transient having a strong band at 480 nm, which was assigned to monomeric $TS^{\bullet+}$ (Figure 9). When the same experiment was carried out

Scheme 13

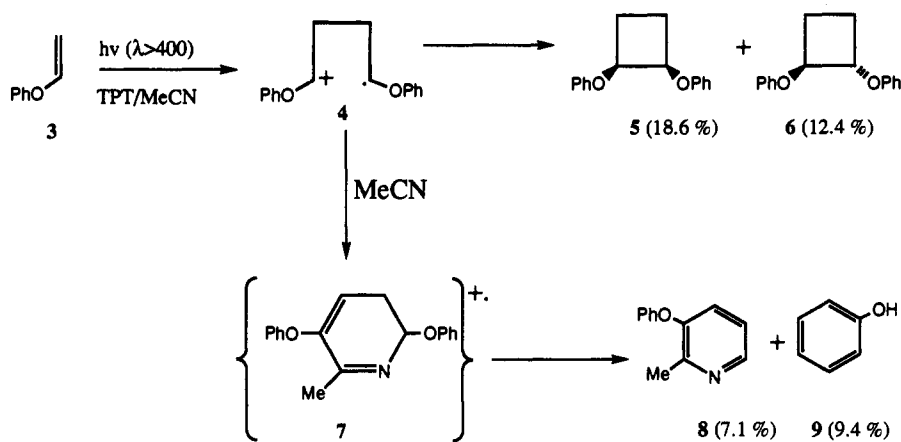

Scheme 14

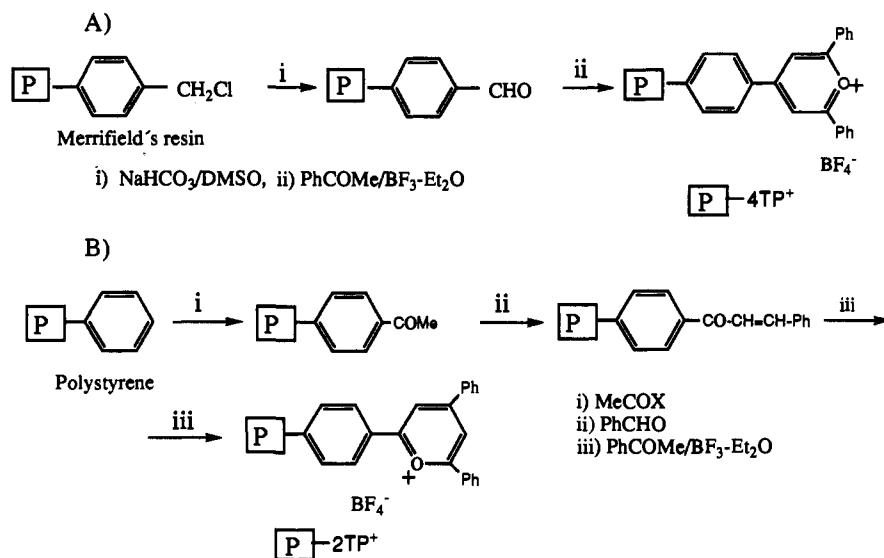

using much more concentrated solutions of TS (4.3×10^{-2} M) a careful inspection of the transient spectrum revealed that a different species ($\lambda_{\text{max}} = 474$ nm, lower extinction coefficient, shoulder at 445 nm) was generated. Its growth corresponded to the initial fast decay of $\text{TS}^{+\cdot}$. Scavenging of this secondary intermediate by 1,4-dimethoxybenzene ($E_{\text{D}^{++}/\text{D}} = 1.34$ V vs SCE) under conditions where $\text{TS}^{+\cdot}$ was observed, further supported its assignment as dimeric TS radical cation ($\text{TS}_2^{+\cdot}$),

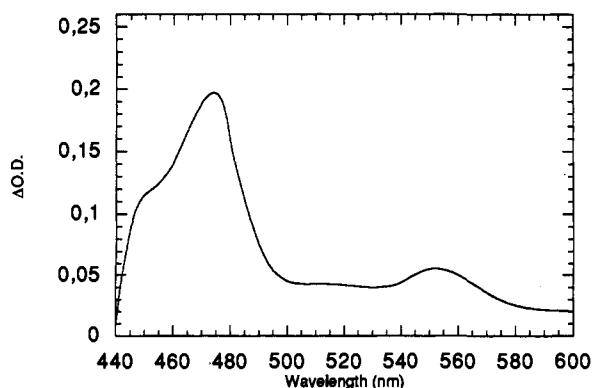
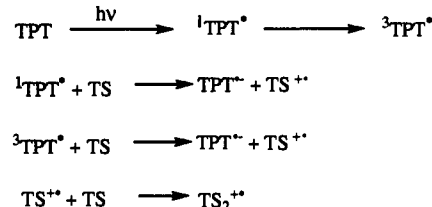

Figure 9. Transient absorption spectrum assigned to dimeric *trans*-stilbene radical cation obtained upon 408-nm excitation of a solution of TPT (6.2×10^{-5} M) and *trans*-stilbene (4.3×10^{-2} M) in CH_2Cl_2 . (Adapted from ref 71.)

resulting from the reaction of $\text{TS}^{+\cdot}$ with neutral TS (Scheme 15).

Scheme 15



The TS dimerization rate constant estimated by pseudo-first-order analysis of the 480-nm band decay was $2 \times 10^7 \text{ dm}^3 \text{ mol}^{-1} \text{ s}^{-1}$. This value is lower than the reported dimerization rate constant for 1,1-diphenylethylene radical cation under comparable ET conditions by a factor of 10^3 .⁷² On the other hand, it is noteworthy that similar studies on the concentration dependence of the transient absorption spectra for triphenylethylene and tetraphenylethylene failed to detect dimeric radical cations. These results put together seem to indicate that the steric hindrance to rotation around the C=C double bond plays a decisive role in determining the feasibility of the TPT-photosensitized dimerization.

In this context, a comparative study on the preparative dimerization of 1,1-diphenylethylene using TPT

and cyanoaromatics has shown remarkable differences in activity and selectivity between both types of photosensitizers.³² Thus, TPT was at least twice more efficient than DCA and gave almost selectively [$4\pi + 2\pi$] cycloadducts (*vide infra*) in contrast with the predominant formation of the head-to-head cyclobutane dimer in the case of cyanoaromatics.

C. [$4\pi + 2\pi$] Dimerizations

It was found that substituted cyclohexadienes undergo an efficient TPT-sensitized Diels–Alder cycloaddition to form exclusively the corresponding [$4 + 2$] adducts (Scheme 16).^{31,32,73,74} This process displayed a

Scheme 16

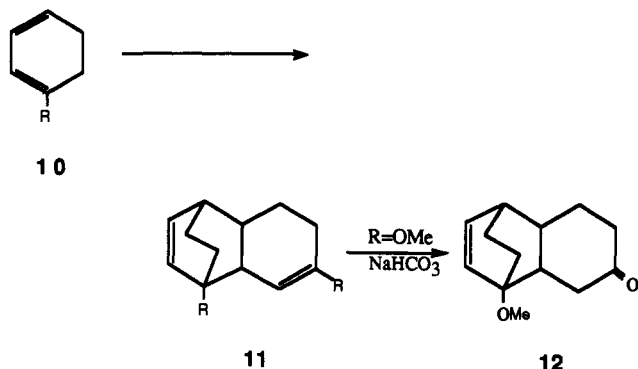

R	method	total yield	<i>endo:exo</i> ratio
OCH ₃	$h\nu^a$	70 ^b	1.2:1
OCH ₃	e^-^c	35	3.7:1
OAc	$h\nu^a$	25	6:1
OAc	e^-^c	14	17:1

^a $\lambda > 345$ nm, CH₂Cl₂ as solvent, TPT 10⁻³–10⁻⁴ M. ^b The tricyclic ketone was the isolated product. ^c Electrochemical anodic oxidation using a 1:1 mixture of MeCN and CH₂Cl₂ as solvent and 0.1 M of LiClO₄ as electrolyte (refs 32 and 74).

remarkable *endo* selectivity, albeit generally lower than that obtained when the radical cation is generated electrochemically.⁷⁵ These results contrast with energy transfer photosensitization, where [$2 + 2$] cyclohexadiene dimers are the most characteristic products.⁷⁶ Likewise, [$2 + 2$] dimers are sometimes obtained with other PET sensitizers.⁷⁷

TPT exhibited again several advantages over cyanoaromatics.⁷⁴ Thus, appreciable lower concentrations of the sensitizer (typically 0.1 mol %) were required, irradiation times were drastically reduced and simple light sources could be used. In addition, the TPT-initiated Diels–Alder reactions of electron-rich dienophiles seems to be of wider applicability.

Likewise, the TPT-sensitized cyclodimerization of unsubstituted 1,3-cyclohexadiene affords a mixture of the Diels–Alder dimers. On the basis of concentration effects, it has been proposed that the *endo* dimers would be formed from solvent-separated ion pairs (SSIP) or free ions (FI), while the *exo* isomers might arise from contact ion pairs (CIP).⁷⁷ This reaction has also been attempted using two polystyrenes containing pyrylium rings.³² Much longer reaction times were required than in the homogeneous reaction (7 h *vs* 45 min) and remarkably lower product yields were achieved (16% *vs* 70%) when using these heterogeneous sensitizers (Scheme 17). It was found that the aromatic rings present in the polymeric backbone and/or the residual

Scheme 17

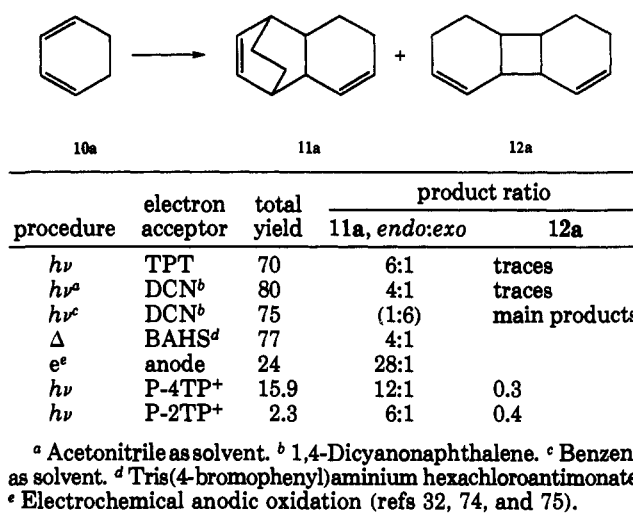

^a Acetonitrile as solvent. ^b 1,4-Dicyanonaphthalene. ^c Benzene as solvent. ^d Tris(4-bromophenyl)aminium hexachloroantimonate. ^e Electrochemical anodic oxidation (refs 32, 74, and 75).

carbonyl groups can behave as triplet sensitizers, especially for irradiation wavelengths between 300 and 400 nm, causing a dramatic decrease on the regio- and stereoselectivity of the cyclodimerization.³²

On the other hand, arylethylenes and phenylacetylene also underwent TPT-sensitized PET [$4 + 2$] dimerization with participation of an aromatic C=C double bond.^{32,78} As a general rule, the tetralines 14 primarily formed underwent further dehydrogenation under the reaction conditions (Scheme 18).

Scheme 18

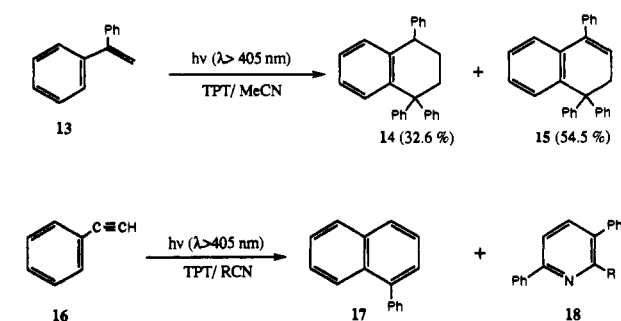

In fact, as we will discuss later, dehydrogenation to form conjugated C=C double bonds is another general process that can be accomplished by TPT photosensitization. In the case of the 1,1-diphenylethylene (DPE) dimerization via electron transfer, it has been claimed that different products arise from different stages of the radical ion pair development.⁷² Thus, the head-to-head [$2\pi + 2\pi$] dimer 19 would be formed from

Scheme 19

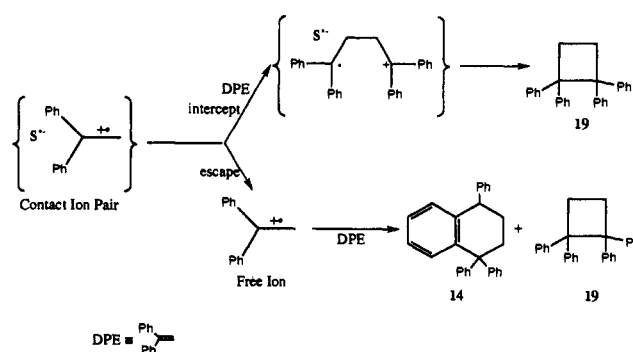

Scheme 20

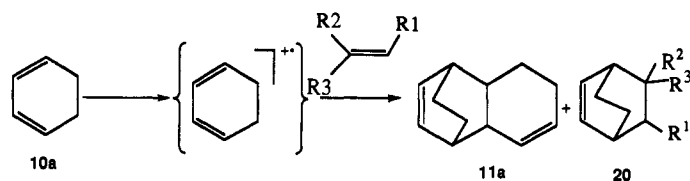

R1	R2	R3	molar ratio ^a (solvent) ^b	sens (mmol)	11a (%) (endo:exo)	20 (%) (endo:exo)
CH=C(CH ₃) ₂	CH ₃	CH ₃	2:10 (D)	TPT (0.1)	12 (6:1)	39 (5:3)
Ph	H	H	1:5 (D)	TPT (0.06)	11 (6:1)	38 (10:1)
Ph	H	H	1:1 (D)	TPT (0.05)	19 (6:1)	13 (10:1)
Ph	H	CH ₃	1:10 (D)	TPT (0.03)	46 (5:1)	32 (>97:2)
Ph	H	CH ₃	2:10 (D)	TPT (0.035)	48 (5:1)	19 (>97:2)
OPh	H	H	0.11:1 (A)	TPT (1)	12.4 (15:2)	19.7 (5:2)
OPh	H	H	0.11:1 (A)	P-4TP ⁺ ^c	5.9 (1.7:1)	1.7 (2.4:1)
OPh	H	H	0.11:1 (A)	P-2TP ⁺ ^c	3.0 (5.2:1)	0.5 (4:1)
OPh	H	H	0.11:1 (A)	DCA (1)	15.6 (15:2)	29.4 (9:4)
-OCH ₂ O-		H	1:1 (A)	TPT (d)	d	d (1.3:1)

^a Cyclohexadiene to alkene. ^b D = dichloromethane, A = acetonitrile. ^c 0.42 g of polymer in 50 mL acetonitrile. ^d Not given (refs 32 and 75).

the contact ion pair, while the free ions would give preferentially the $[4\pi + 2\pi]$ tetrahydronaphthalene adducts 14 (Scheme 19).

Accordingly, the fact that only very minor amounts of 1,1,2,2-tetraphenylcyclobutane were formed in the TPT-photosensitized DPE dimerization (compared with cyanoaromatics) would indicate an enhanced separation and escape of the contact radical ion pairs. This has been rationalized in terms of the lack of Coulombic attraction between the acceptor and the donor, owing to the lack of charge separation during electron transfer.

Additionally, when the TPT-photosensitized dimerization of phenylacetylene was performed in nitriles as solvents, trapping of the dimeric radical cation by the solvent was observed (Scheme 18). Depending on the alkyne concentration, the ratio between dimerization and formation of the corresponding 3,6-diphenylpyridine 18 became as low as 0.08. It is worth mentioning that 9,10-dicyanoanthracene (DCA) failed to promote this dimerization, owing to the fact that electron transfer from phenylacetylene to ¹(DCA)* is an endothermic process.

D. $[4\pi + 2\pi]$ Cross Cycloadditions

The mixed cycloaddition between 1,3-cyclohexadiene and alkenes using TPT as photosensitizer has been reported (Scheme 20).^{31,32,69,73,75,77}

Although self-dimerization of the alkenes was a minor process, the Diels–Alder dimers of cyclohexadiene were actually the major products when an excess of diene was employed. This product distribution points to the intermediacy of the diene radical cation (instead of the dienophile radical cation) and would violate the “role selectivity” of radical–cation Diels–Alder reactions,⁷⁹ according to which only dienophile radical cations should yield Diels–Alder products. The *endo/exo* stereoselectivity was found to depend on the diene to dienophile ratio and the reaction conditions: excess of alkene enhanced the *endo* configuration, while the opposite was true for an excess of cyclohexadiene. Once again, the efficiency and selectivity of the polymer-

bound pyrylium sensitizers for this mixed cycloaddition was markedly lower.³²

It has been found that the heterocyclic C=C double bond of indole can also participate as a dienophile in the TPT-induced radical cation Diels–Alder reaction using cyclic dienes.^{80,81} However, the much lower oxidation potential of the expected tetracyclic carbazole derivatives 22 ($E_{D^{++}/D} = 0.7$ V vs NHE for the parent tetrahydroethanocarbazole) compared with the indolic precursors was responsible for the low conversions, due to the preferential quenching of excited TPT by the products. In order to force the reaction to completion, an elegant strategy involving irradiation in the presence of an equivalent amount of acetyl chloride has been developed. Under these reaction conditions, the *N*-acetyl derivative of the $[4 + 2]$ cycloadduct (24), which has a higher oxidation potential (1.54 V vs NHE) than the indole (1.31 V vs NHE), was formed in high yields. It was found that *N*-acylation of the initial adduct was taking place as it was being formed, thus avoiding the progressive slow down of the photochemical reaction rate with increasing product formation (Scheme 21).

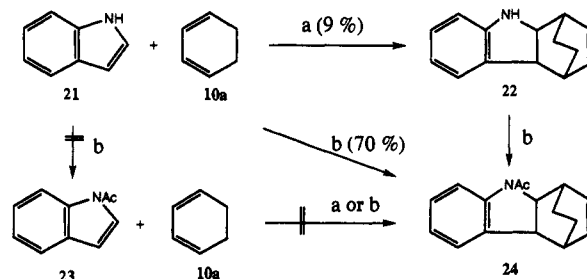
Scheme 21^a

^a Conditions: (a) $h\nu$ ($\lambda > 345$ nm), TPT (5 mol %), CH₂Cl₂; (b) the same, adding MeCOCl/NaHCO₃.

Moreover, this methodology was found to be general, since analogous conditions were used to perform successfully the TPT-sensitized PET cycloaddition of indole and a large variety of substituted 1,3-cyclohexadienes 25, that could not be effected in the absence of acylating agent. In these reactions only one regioisomer (26) was usually formed, as a mixture where the *endo* diastereomer was predominating (Scheme 22).

Scheme 22

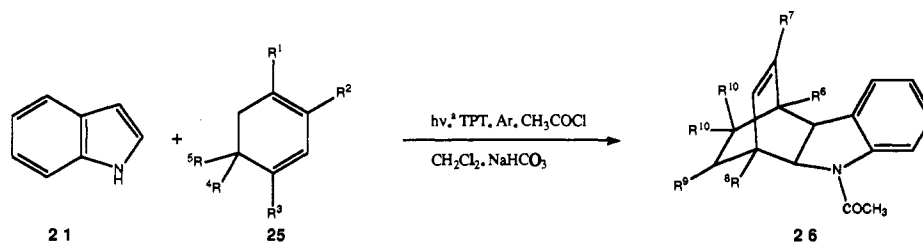

R ¹	R ²	R ³	R ⁴	R ⁵	R ⁶	R ⁷	R ⁸	R ⁹	R ¹⁰	product yield (%)	endo:exo
H	H	H	H	H	H	H	H	H	H	70	3.3:1
CH ₃	H	CH(CH ₃) ₂	H	H	CH ₃	H	CH(CH ₃) ₂	H	H	43	1.7:1
H	CH ₃	H	CH(CH ₃) ₂	H	H	CH ₃	H	CH(CH ₃) ₂	H	57	2.4:1
H	CH ₃	H	CH(CH ₃) ₂	H	H	CH ₃	H	CH(CH ₃) ₂	H	67 ^b	4.6:1
OAc	H	H	H	H	OAc	H	H	H	H	31	2.3:1
H	OAc	H	H	H	H	OAc	H	H	H	59	3:1
CH ₃	H	H	CH ₃	CH ₃	H	H	CH ₃	H	CH ₃	23 ^c	>98:2

^a Reaction conditions: 4 mmol of cyclohexadiene, 2 mmol of indole, 2 mmol of acetyl chloride, 5 mol % of TPT, and 350 mg of NaHCO₃ in oxygen-free CH₂Cl₂, using a 450-W xenon lamp ($\lambda \geq 345$ nm). ^b Irradiation with a 250-W halogen lamp. ^c Same experimental conditions but using 2.5 mol % of TPT (ref 81).

This regioselectivity can be explained by invoking radical attack of the indol-3-yl radical cation on the 4-position of substituted 1,3-cyclohexadiene. The PET mechanism was supported by observation of an efficient fluorescence quenching of the pyrylium salt by indole, and by the fact that the reaction was quenched by the presence of aromatic compounds with oxidation potential lower than that of indole (Scheme 23).

Scheme 23

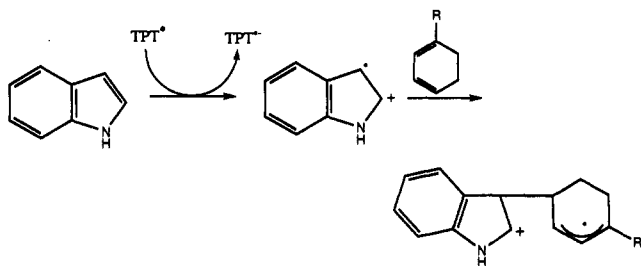

Semiempirical calculations are in good agreement with this hypothesis, thus confirming the feasibility of a nonsynchronous-nonconcerted pathway.⁸² Furthermore, the obtention of both *cis* and *trans* products in the reaction of indole with 1,4-disubstituted exocyclic dienes of known configuration constitutes a further support in favor of the proposed mechanism and against a concerted route.^{82,83}

The above cycloaddition appears to be limited to indoles lacking substituents in the heterocyclic ring and to dienes with a rigid *s-cis* conformation. Besides acetyl chloride, methyl orthoformate, and *p*-toluenesulfonyl chloride were also effective, while benzoyl chloride was inadequate as acylating agent. 2-Vinylindoles play the dienophilic role in the [4 + 2] cross cycloaddition with 1,3-cyclohexadienes and styrenes (see section III.G).⁸⁴

It has also been reported that 1-hexyne undergoes a TPT-photosensitized [4 + 2] cross cycloaddition with phenylacetylene to form 1-butylnaphthalene along with a dimer (17) and the pyridine-derived byproducts 18a, 29, and 30 (Scheme 24).⁷⁸

Scheme 24

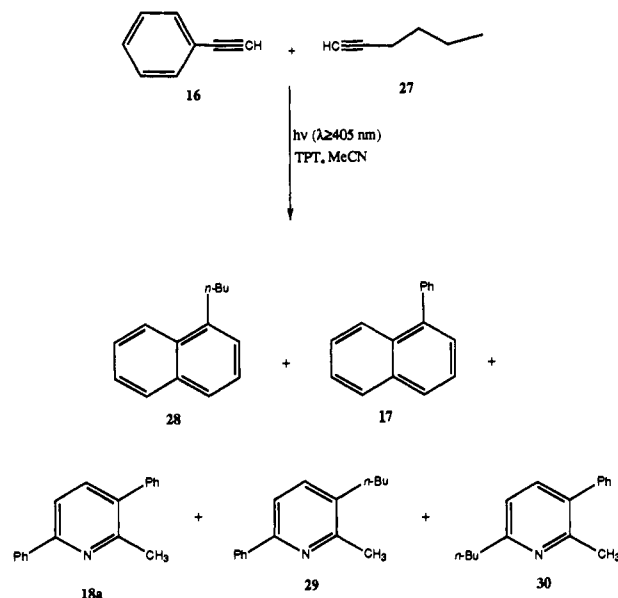

E. Cycloreversions

Splitting of cyclobutanes to afford two 2π systems constitutes another general reaction type that can be efficiently promoted by TPT photosensitization. Thus, upon visible light excitation in the presence of catalytic amounts of pyrylium salts, the diphenyl-substituted bishomocubane 31 of Scheme 25 ($E_{D^{+}/D} = 1.40$ V vs SCE) gave quantitatively the corresponding tricyclic diene 32.⁸⁵ It was found that the efficiency of ring opening depends on the reduction potentials but not on the triplet energies of the sensitizers.⁸⁶ In the case of cyanoaromatics, a characteristic emission corresponding to a charge-transfer exciplex between the diene and DCA or 3,9-dicyanophenanthrene was observed, showing that the cycloreversion was an adiabatic photochemical process.⁸⁷ In addition, this cycloreversion can also be promoted by typical ground-state electron acceptors in the dark. All these data supported an electron-transfer mechanism.

Likewise, almost quantitative chemical yields were also obtained under the same experimental conditions

Scheme 25

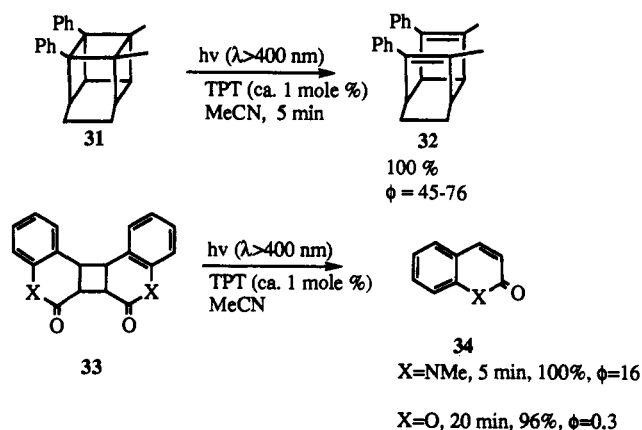

for the transformation of the cyclobutane dimers of 1-methylquinolone ($E_{D^{++}/D} = 1.3 \text{ V vs SCE}$) and coumarin (1.92 V vs SCE) into their corresponding monomers (Scheme 25). It was found that methoxy substitution at the *para* position of the TPT phenyl rings dramatically reduced the quantum yield for this cycloreversion. This fact was interpreted as the result of a more rapid back-electron transfer, especially taking into account that according to the Rehm-Weller equation this step must be more exothermic for the trimethoxy-substituted sensitizer. In addition, trityl salts were found to be much less efficient than pyrylium salts to promote cycloreversion.

On the basis of studies on the bishomocubane cage molecule,⁸⁸ a PET chain mechanism has been proposed for these reactions (Scheme 26). Thus, high quantum

Scheme 26

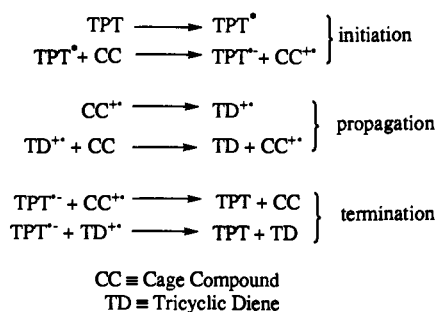

yields (usually greater than unity) were measured and efficient quenching of the reaction was achieved by 1,2,4,6-tetramethoxybenzene ($E_{D^{++}/D} = 0.81 \text{ V vs SCE}$) but not by trimethoxybenzene (1.49 V vs SCE). In good agreement with this reactive scheme, the quantum yield increased linearly with the substrate concentration up to 10^{-2} M , while for higher concentrations a plateau around $\Phi \approx 80$ was attained. Moreover, in accordance with the expression deduced for Φ , the quantum yield also increased as the light intensity was reduced. However, as in the case of indene dimerization, the apparent catalytic function of oxygen, more than doubling the quantum yield without altering the product distribution or bleaching the sensitizer, is still not clearly understood.

A related skeletal pericyclic rearrangement with cycloreversion of cage compounds comprising 1,2-diaryl substituted 3-vinylbicyclo[2.2.0]hexane moiety (35) has also been reported (Scheme 27).⁸⁹

Scheme 27

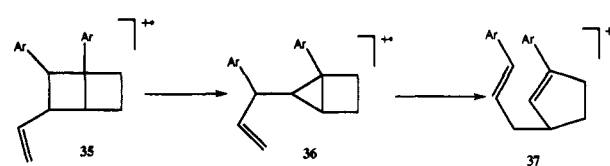

Likewise, TPT-sensitized photolysis of the cage ketone 38a of Scheme 28 resulted in the quantitative

Scheme 28

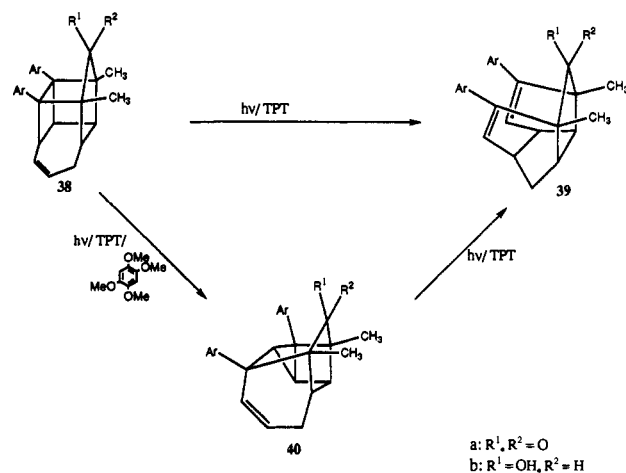

formation of the corresponding dienone 39a, with a limiting quantum yield of 3.3 (dependent on the concentration). Quenching experiments using 1,2,4,5-tetramethoxybenzene revealed that the reaction involved the intermediacy of another cage compound with 1-phenyl-5-(1-phenylallyl)bicyclo[2.1.0]pentane substructure (40) and therefore, the overall transformation consisted of two consecutive elementary [$\sigma 2 + \sigma 1$] and [$\pi 2 + \sigma 2 + \sigma 1$] transpositions.

As expected for a PET mechanism, this reaction could also be thermally promoted with tris(*p*-bromophenyl)aminium hexachloroantimonate and photochemically using *p*-chloranil as sensitizer. However, in spite of the very negative free-energy change, DCA was found to be inefficient to induce this pericyclic rearrangement, unless some inorganic salt (10^{-2} M) was added to the acetonitrile-dichloromethane solution. This was interpreted in terms of the occurrence of a deactivating back-electron transfer from DCA^+ , reducing the lifetime of the radical cation and preventing the rearrangement.

The presence of a vinyl substituent at the 3-position of the 1,2-diaryl bicyclohexane seems to be a structural prerequisite for this novel skeletal transposition, while the rest of the cage molecule does not participate directly in the reaction. Accordingly, the analogous saturated compounds were recovered unchanged under the TPT-sensitized photolysis. On the other hand, the analogous cage alcohol 38b, obtained by reduction of the ketone with LiAlH_4 , underwent the same pericyclic rearrangement to 39b, following identical reaction mechanism.

F. Z/E Isomerization

Early reports on the use of TPT and other pyrylium salts for the Z/E isomerization of stilbene (Scheme 29) showed⁹⁰ that this process does not follow an energy transfer mechanism since the composition of the photostationary mixture contained 96% of the *trans*

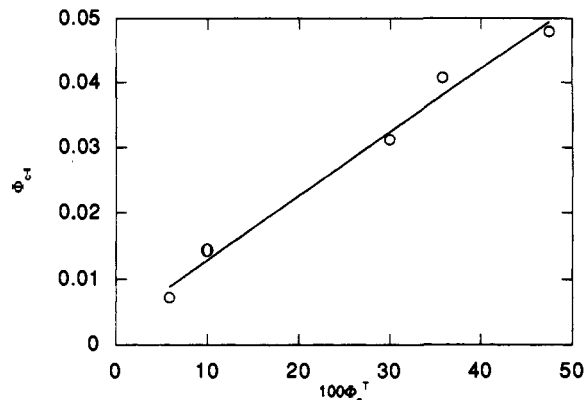

Figure 10. Plot of the quantum yield for the *cis*-stilbene isomerization ($\Phi_{c \rightarrow t}$) vs the quantum yield for the quenching of TPT triplet by CS (Φ_q^T). The experimental points correspond to different CS concentrations in the range 9.4×10^{-4} to 8.4×10^{-2} M. (Adapted from ref 66.)

isomer instead of the 14% predicted according with the triplet excitation energies of the photosensitizer.⁹¹

A better understanding of the TPT-photosensitized stilbene C=C double bond isomerization has emerged from more recent laser flash photolysis (LFP) studies.⁶⁶ Thus, both *cis*- and *trans*-stilbenes (CS and TS, respectively) were found to be able to quench both the singlet and the triplet states of TPT at nearly diffusion-controlled rates. The free energies of electron transfer from CS and TS ($E_{D^{+}/D} = 1.59$ and 1.49 V vs SCE, respectively) to singlet and triplet TPT were estimated to be highly exothermic by substituting in the Rehm-Weller equation the values of the oxidation potentials and the excitation energies of the species involved. As a matter of fact, pyranil radical (λ_{\max} 550 nm), CS^{•+} (λ_{\max} 515 nm), and/or TS^{•+} (λ_{\max} 480 nm) could be easily detected as transient species characterized by their absorption spectra. Interestingly, upon LFP of TPT in the presence of TS only the transient absorption due to TS^{•+} could be recorded; by contrast, in the experiments using CS both isomeric CS^{•+} and TS^{•+} radical cations were observed.

The TPT-sensitized isomerization of CS is also interesting from the point of view of the influence of the sensitizer spin multiplicity on the isomerization efficiency. Thus, as the concentration of CS decreased, quenching of the TPT singlet excited state was less efficient and population of triplet state through intersystem crossing from the singlet was higher. Under these conditions, a linear relationship between the apparent quantum yields for the isomerization ($\Phi_{c \rightarrow t}$) and CS quenching of the triplet (Φ_q^T) was observed (Figure 10). Extrapolation to $\Phi_q^T = 0$ and 1 gave 0.003 and 0.11, respectively, as the limiting $\Phi_{c \rightarrow t}$ values.

Scheme 29

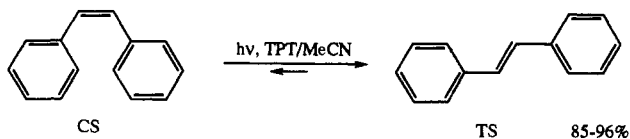

These values indicate that with no triplet quenching ($\Phi_q^T = 0$), there is no *Z/E* isomerization, and thus no measurable reaction appears to take place by interaction with singlet TPT. Moreover, the possibility of an energy-transfer pathway for the one-way *cis*-to-*trans*

isomerization can be safely disregarded since the triplet energy of CS ($E_T = 60.3$ kcal/mol) is much higher than that of TPT ($E_T = 53$ kcal/mol). In sodium dodecyl sulfate micellar solutions both excited singlets and triplets of TPT were effectively quenched by CS, but isomerization of CS to TS took place exclusively from the triplet radical ion pair $^3(\text{TPT}^{\bullet-}\text{CS}^{\bullet+})$.⁹² In addition, the $\Phi_{c \rightarrow t}$ in these compartmentalized heterogeneous systems was up to four times higher than in CH_2Cl_2 solution. This increase probably reflects the fact that intersystem crossing from the triplet to the singlet radical ion pair is prevented by avoiding the escape of the contact ion pairs beyond the boundaries of the micelles (Scheme 30).

Scheme 30

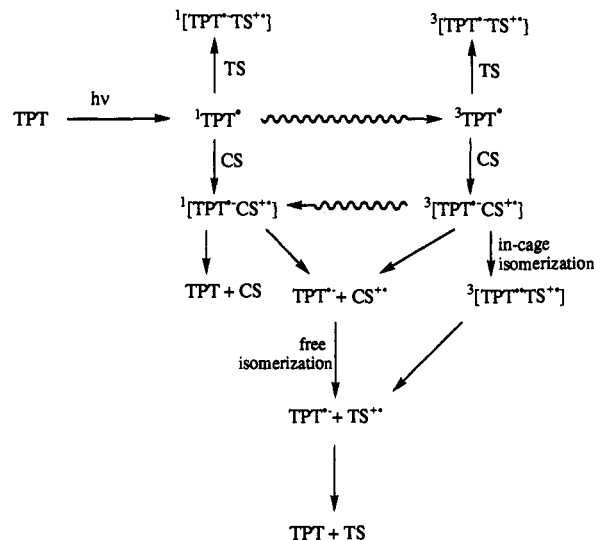

The above findings are in sharp contrast with the DCA-photosensitized isomerization of CS, where the linear relationship between $\Phi_{c \rightarrow t}$ and the quantum yield of $^1\text{DCA}^*$ quenching, along with a small magnetic field effect, has shown that this rearrangement occurs mainly from the singlet excited state.⁹³ It has been suggested that the differential behavior of DCA and TPT can be interpreted in terms of the Marcus inverted region theory, *i.e.* for highly exothermic electron transfer, the more negative are the free-energy changes the slower should be the process. Thus, the radical ion pair $^1(\text{TPT}^{\bullet-}\text{CS}^{\bullet+})$ should decay to the starting materials ($\Delta G = -1.9$ eV) much faster than it should do the analogous $^1(\text{DCA}^{\bullet-}\text{CS}^{\bullet+})$ pair ($\Delta G = -2.6$ eV).

On the other hand, a quantitative estimation of the relative contributions of CS isomerization within the contact ion pair or as free ion after cage escape has been made by means of azulene (Az, $E_{D^{+}/D} = 0.95$ V vs SCE) as a quencher. The experiments were carried out using diluted solutions of Az ($\approx 10^{-5}$ M). Under these conditions, the TPT triplet was almost exclusively quenched by CS (4.2×10^{-3} M), and the effect of Az was attributed to scavenging of the free CS^{•+} ion. Therefore, the unquenchable portion of isomerization (around 25%) was ascribed to the percentage of "in-cage" reaction (Figure 11).

In this context, it has been recently found that the percentage of unquenchable "in-cage" isomerization can be as high as 65% when photosensitization by the 2,4,6-triphenylpyrylium (TP^+) cation takes place within the

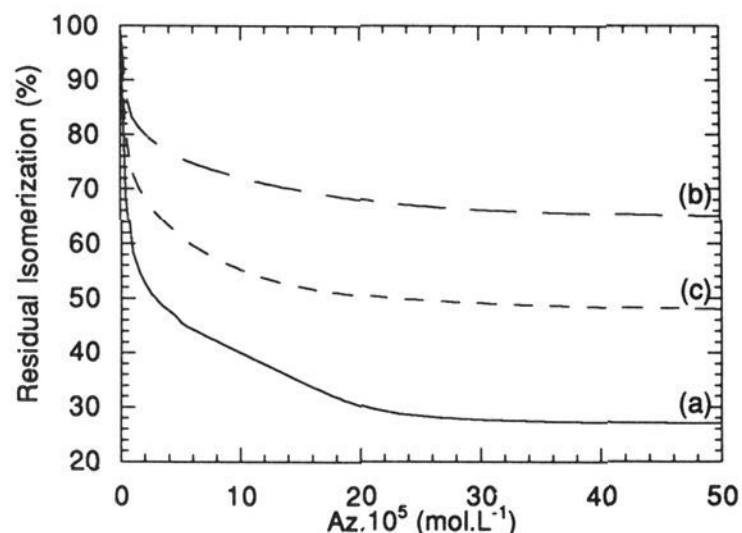

Figure 11. Different contribution of the “in-cage” [TP⁺CS^{•+}] isomerization to the total yield as determined by Az quenching in homogeneous CH₂Cl₂ solution using TPT (a), or heterogeneous conditions using TP⁺ adsorbed within Y zeolite (TPY) (b), or extralarge pore zeolitic aluminosilicate (TPMCM-41) (c). (Adapted from refs 94 and 97.)

cavities of large pore zeolites.⁹⁴ This effect could arise from the retardation of back-electron transfer as a consequence of the strong internal electrostatic fields experienced inside the micropores of these crystalline solids, which must stabilize the generated radical ion pair.^{95,96} Since TP⁺ is a bulky molecule (≈ 13 Å of diameter), its incorporation within the internal surfaces of Y faujasite was not accomplished by ion exchange. Therefore, encapsulation of the 2,4,6-triphenylpyrylium cation was carried out by ship-in-a-bottle reaction of chalcone with acetophenone (Scheme 31) using the active sites of an acidic Y zeolite as catalyst.⁹⁴

Formation of imprisoned TP⁺ as charge-compensating cation was ascertained by UV-vis spectrophotometry and FT-IR spectroscopy of the resulting yellow materials. Mass balance, thermogravimetric analyses of the solid, and pyridine titration of the remaining Brønsted sites indicated that roughly one-third of the cavities are occupied by TP⁺, while the remaining supercages were still accessible to organic guests. A visualization of the resulting TP⁺ immobilized within the faujasite Y spherical supercages was made using a molecular-modeling program (Figure 12).

In agreement with the high “in-cage” isomerization percentage of the intrazeolite process and with the fact that photooxygenation of stilbenes arises mostly from free radical cations, it was found that isomerization was not perturbed by the presence of oxygen, as

Scheme 31

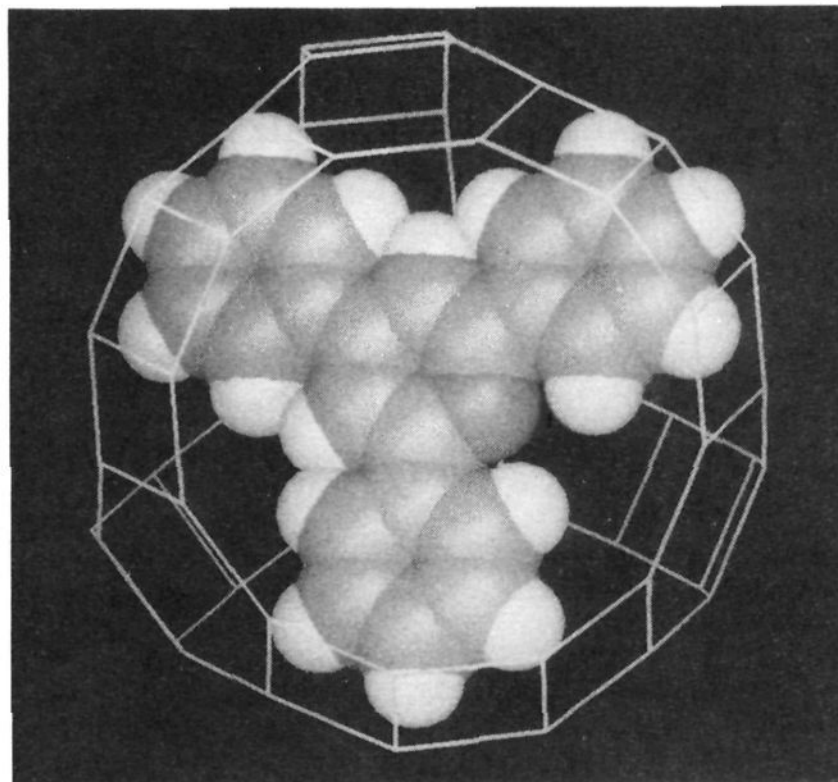
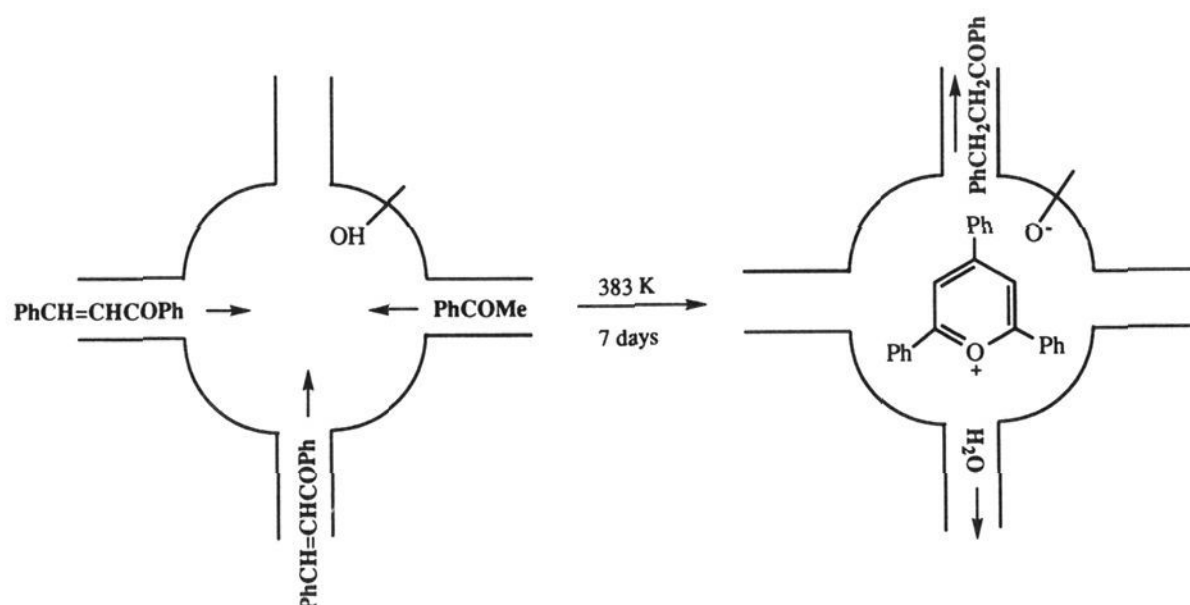

Figure 12. Molecular modeling simulation of the TP⁺ cation imprisoned within the spherical cavities of the Y zeolite. (Reprinted from ref 94. Copyright 1994 American Chemical Society.)

evidenced by the absence of byproducts arising from oxidative cleavage. This result contrasts with the extensive photooxygenation produced by TPT under homogeneous conditions (see photooxygenation below for discussion).

In spite of the advantages associated to the immobilization of TP⁺ within the large pore zeolite, the chemical yields of the CS isomerization were still far from optimum. This can be due to restrictions imposed by the zeolite framework to the internal diffusion of the organic molecules through the micropores. In fact, inclusion of TP⁺ within a novel extralarge pore zeolite (MCM-41) with unidimensional channel structure (20 Å of pore diameter) provided a suitable balance between cage effect and molecular traffic, increasing dramatically the efficiency of the process.⁹⁷

G. Sigmatropic Rearrangements

The mechanism proposed for the [4 + 2] cycloaddition between 2-vinylindoles **41** and electron-rich dienophiles (R³CH=CHR⁴) involves rearomatization of the initial adduct **43** via [1,3]-H shift.⁸⁴ This process

is symmetry forbidden for the neutral molecule, but not for the radical cation. When the vinylindole is suitably substituted, no [1,3]-H shift is possible. In general, dehydrogenation (section III.H.3) was observed under the employed conditions (Scheme 32).

Scheme 32

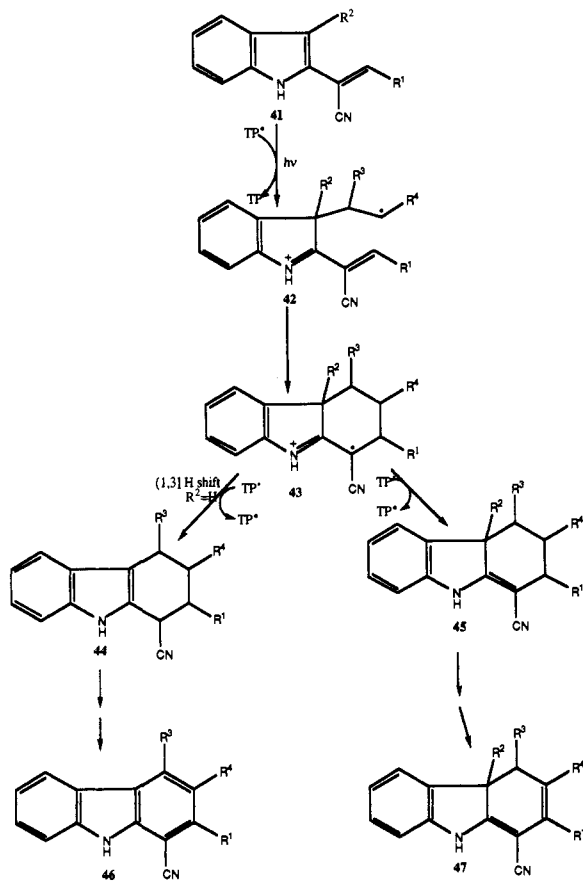

Excited TPT was found to promote the Cope rearrangement of 2,3,5-triphenyl-1,5-hexadiene (48, Scheme 33). Although this type of reaction is not common in

Scheme 33

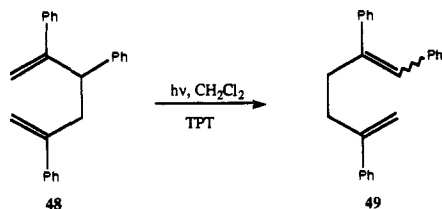

radical cation chemistry,^{79,98} a few related examples have been reported with DCA as photosensitizer.⁹⁹

H. Oxygenation/Dehydrogenation

1. Oxygenation of Olefins

In recent years, much attention has been devoted to ET photooxygenation.⁵ As stated above, TPT produces neither singlet oxygen nor superoxide radical anion and hence it is the photosensitizer of choice to investigate the reactions of alkene radical cations with molecular oxygen.

Since related processes have been found to occur in the case of adamantylideneadamantane (AA, 50) mainly using triarylamine cation radicals,¹⁰⁰⁻¹⁰³ the TPT-

photosensitized oxygenation of this compound (Scheme 34) has been studied in detail.^{36,84} When a solution of

Scheme 34

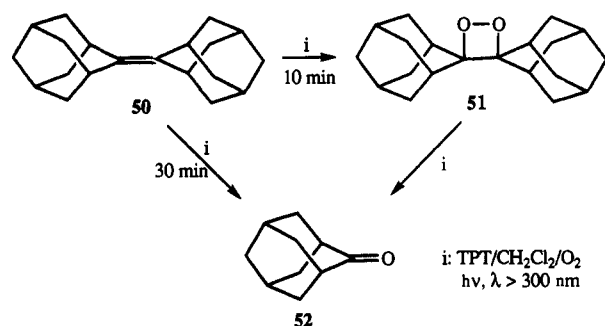

AA ($5 \times 10^{-2} \text{ M}$) and TPT ($2.4 \times 10^{-4} \text{ M}$) in methylene chloride was irradiated through Pyrex with bubbling oxygen, for 10 min, the dioxetane 51 was obtained in 90% yield (based on reacted AA). Prolonged irradiation (30 min) gave adamantanone (75% isolated yield).

The most salient features of this reaction were the following: (a) the catalytic role of TPT, suggested by the fact that AA consumption was much higher (roughly 40 times) than TPT bleaching, and (b) the efficient quenching observed upon addition of 1,4-dimethoxybenzene, whose oxidation potential ($E_{\text{D}^{++}/\text{D}} = 1.34 \text{ V vs SCE}$) is lower than that of AA (*ca.* 1.5 V vs SCE).¹⁰⁴ On this basis, an electron-transfer mechanism (Scheme 35) was proposed.

Scheme 35

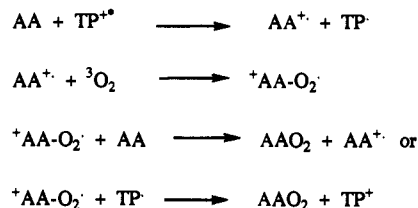

Direct evidence for this rationalization and further insight into the nature of the involved TPT excited states were obtained by fluorescence quenching and laser flash photolysis.^{36,64} The fluorescence of TPT was efficiently quenched by AA, following Stern-Volmer behavior. The quenching rate constant was calculated to be $2.4 \times 10^{10} \text{ dm}^3 \text{ mol}^{-1} \text{ s}^{-1}$. Laser flash photolysis of TPT ($1.6 \times 10^{-4} \text{ M}$) in the presence of an excess of AA ($6.2 \times 10^{-2} \text{ M}$), to ensure that most of the TPT singlets were quenched by AA, gave a transient absorption (550 nm) assigned to TP^+ . On the other hand, when the LFP experiment was performed with concentrations of AA ($1.4 \times 10^{-4} \text{ M}$) for which quenching of the excited TPT singlet was negligible, TP^+ was also detected. These experiments evidenced that electron transfer occurs from AA to both the singlet and triplet excited states of TPT. Moreover, the absorbance of the transient species at 550 nm was found to be nearly the same for concentrations of AA ranging between 10^{-2} and 10^{-4} M , indicating that triplet-mediated electron transfer was much more efficient in generating free radical ions than the singlet-mediated process. This contrasts with PET oxygenation sensitized by cyanoaromatics, in which only singlet quenching by the electron donors is significant. The low efficiency of

the TPT singlet (which determines the poor quantum yield of the photooxygenation process < 0.1) was attributed to rapid back-electron transfer in the radical ion pair.

Arylolefins constitute another group of compounds whose TPT-photosensitized oxygenation has been intensively studied in recent years.^{32,65,67} For instance, irradiation ($\lambda > 360$ nm) of TPT (*ca.* 10^{-3} M) in the presence of stilbene derivatives (10^{-2} – 10^{-3} M) produced cleavage of the latter, to afford two fragments with a carbonyl group (Scheme 36).^{65,67}

Scheme 36

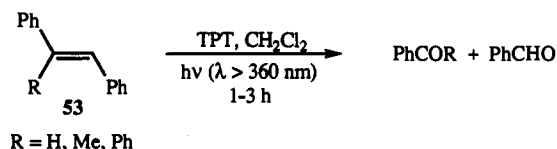

Control experiments showed that benzaldehyde was a stilbene-derived product.⁶⁷ Under the reaction conditions, photolytic degradation of TPT into benzaldehyde¹⁰⁵ did not take place to a significant extent.

The chemical yield of the products did not depend significantly on the initial olefin concentration, but the degree of conversion increased with decreasing singlet quenching. This suggested triplet-mediated PET oxygenation. Laser flash photolysis (408 nm) of TPT (6×10^{-5} M) in the presence of triphenylethylene (3×10^{-4} M) under argon gave well-defined transient bands at 500 and 550 nm, assigned to the olefin radical cation and the pyryl radical, respectively. It must be stressed that, under the above experimental conditions, singlet quenching was only 2%, but triplet quenching was *ca.* 97%. Calculations based on measurements of the optical density at different olefin concentrations indicated that more than 50% of the products were formed from the TPT triplet, even at 10^{-2} M olefin concentration. The proposed mechanism (Scheme 37) is illustrated for the case of *trans*-stilbene.

Scheme 37

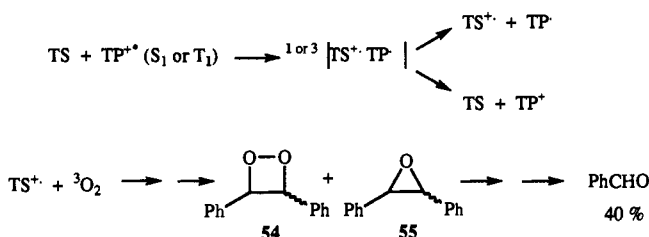

By contrast, the DCA-sensitized photooxygenation of *trans*-stilbene^{106,107} (Scheme 38) is less selective and

Scheme 38

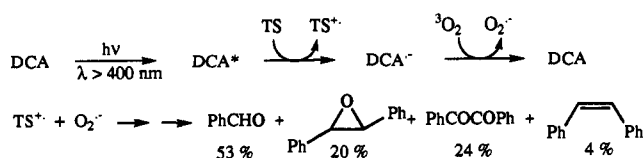

involves the intermediacy of superoxide radical anion.

In an attempt to achieve the singlet oxygenation of TS, methylene blue (MB) was used as photosensitizer.¹⁰⁸ Benzaldehyde was formed very slowly and the reaction

was initially assumed to involve singlet oxygen. However, more recent studies¹⁰⁹ evidenced that the MB-mediated photooxygenation proceeds *via* electron transfer and can be explained by reaction of the TS radical cations with molecular oxygen, as above discussed for the TPT-photosensitized process. Rose Bengal failed to promote the reaction; however, the use of tetraphenylporphine (TPP) resulted in the formation of a complex mixture containing benzaldehyde, the epoxide *t*-55 and the diendoperoxide 57 of TS, together with unidentified products (Scheme 39).¹¹⁰

Scheme 39

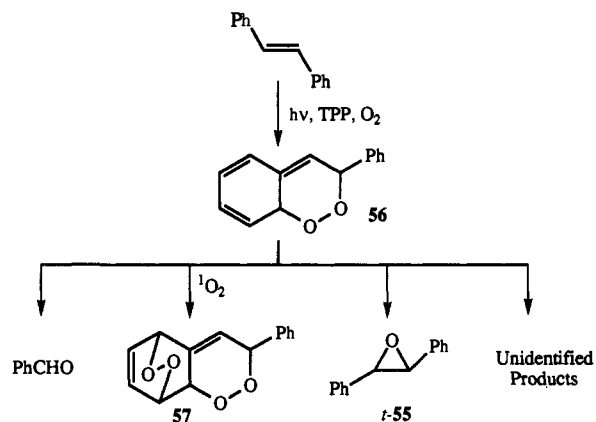

The results obtained in the photooxygenation of TS with different sensitizers nicely illustrate the varied mechanistic routes and product distributions characteristic of the molecular oxygen, superoxide, and singlet oxygen pathways.

Among arylolefins, 1,1-diphenylethylene (DPE) has also attracted considerable interest as substrate for electron-transfer photooxygenation.^{32,72,107,111} The TPT-mediated reaction gave rise to benzophenone and a dimeric 1,2-dioxane (58), whose formation evidenced trapping of the dimeric 1,4-radical cation by oxygen (Scheme 40).

Scheme 40

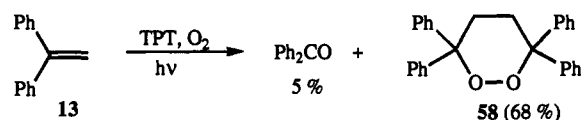

Two different publications have appeared on the DCA-photosensitized reaction of the same olefin. One of them⁷² reported the formation of benzophenone and the 1,2-dioxane and proposed that both products arise from the above-mentioned reaction between a dimeric 1,4-radical cation and molecular oxygen. The other report¹⁰⁷ described isolation of benzophenone and the epoxide of DPE, which were accounted for in terms of superoxide generation and combination with the olefin radical cation. Moreover, irradiation of suspensions of a semiconductor powder (for instance, TiO_2 , at $\lambda = 350$ nm) in a solution of DPE in acetonitrile gave rise to a mixture of benzophenone, the epoxide, and diphenylacetaldehyde. Longer irradiation times resulted in the formation of benzophenone as single product (Scheme 41).¹¹¹

Scheme 41

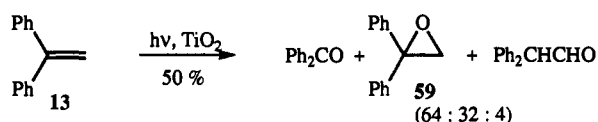

From the mechanistic point of view, this reaction was classified as an electron-transfer process caused by the promotion of an electron into the semiconductor conduction band, with the production of a hole in the valence band. However, the sequence of steps occurring at the semiconductor-liquid interface, which ultimately led to the oxidation products, was not established.

In summary, different patterns of products have been obtained in the case of DPE, depending on the PET-reaction conditions. Nonetheless, further studies are necessary to differentiate between the mechanisms operating in the TPT-mediated process and those associated to the other photosensitizers.

2. α -Acetoxylation of Ketones via the Enol Acetates

The enol acetylation of ketones, followed by TPT-photosensitized oxygenation, has been used in a number of cases to achieve acetoxylation at the position α to the carbonyl group.¹¹²⁻¹¹⁴ Common byproducts are the corresponding α,β -unsaturated ketones and the saturated (deacetylated) ketones (Scheme 42).

Scheme 42

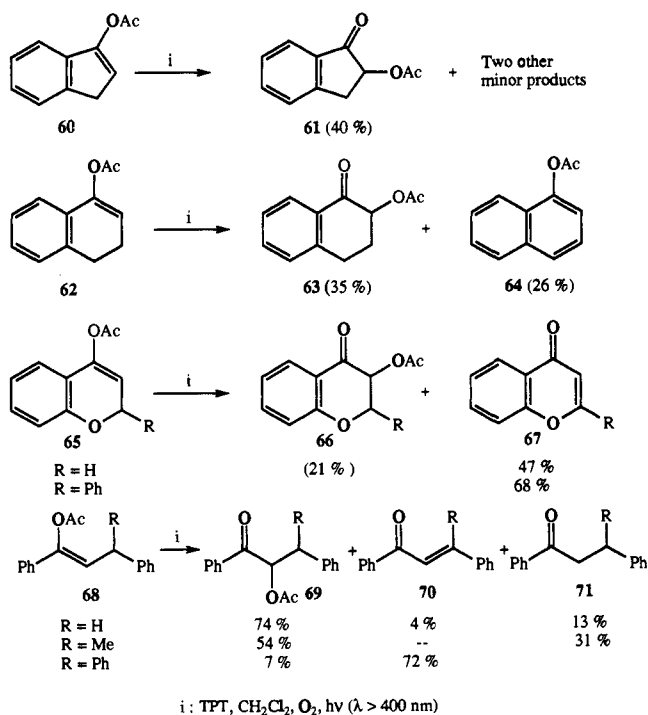

From the preparative point of view, this reaction is equivalent to the anodic oxidation of enol acetates in acetic acid, which also involves radical cations as intermediates and affords α -acetoxyketones and α,β -enones as final products.¹¹⁵ It has been postulated that acetoxyoxiranes **73** are key intermediates in the photosensitized process (Scheme 43), in view of the literature precedents on the formation of oxiranes during the ET photooxygenation of olefins with TPT⁶⁵ or other electron acceptors,^{107,111} and also on the spontaneous rearrangement of acetoxyoxiranes to acet-

Scheme 43

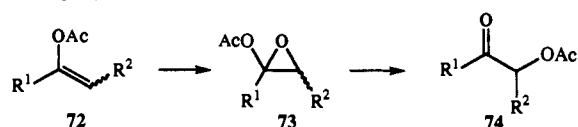

oxyketones.¹¹⁶ In fact, the latter products were directly obtained when the enol acetates were treated with *m*-chloroperbenzoic acid (MCPBA) as epoxidizing reagent.

In this context, an interesting observation was the fact that (*Z*)-1-acetoxy-1,3-diphenyl-1-butene gave 2-acetoxy-1,3-diphenyl-1-butanone as a mixture of two diastereomers (*ca.* 1:1 ratio) upon treatment with MCPBA, while only one diastereomer was obtained in the TPT-sensitized photolysis of the same substrate. Such stereoselectivity is unusual in the PET epoxidation,¹⁰⁷ and deserves more detailed studies.

3. Dehydrogenations

The dehydrogenation of flavanones to flavones is an interesting process in natural products chemistry, which can be achieved by means of a PET reaction using TPT as sensitizer (Scheme 44).¹¹⁷

Scheme 44

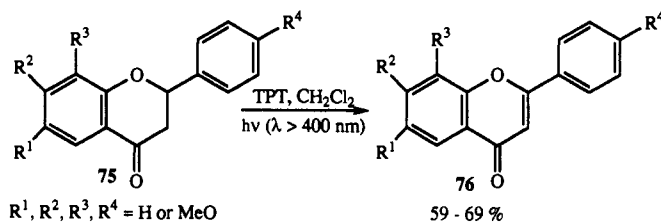

This result has been rationalized in terms of initial electron transfer from the flavanone B ring to the excited pyrylium salt. The substituent effects at this ring (R^4) are in agreement with this picture. Thus, the electron-donating methoxy group enhanced the flavone yield, while the electron-withdrawing nitro group prevented the reaction (the starting material was recovered unchanged). Dimethyl substitution at the A ring produced a different result: besides the expected flavone **78**, a formyl derivative **79** was obtained as a minor product. Its formation was explained through electron transfer from the A ring to excited TPT (Scheme 45).

Scheme 45

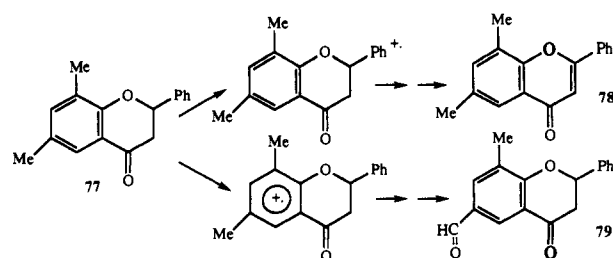

Dehydrogenation resulting in aromatization has been reported as an undesired process in the course of studies on the TPT-photosensitized cyclodimerization or oxygenation of cyclohexadienol acetates (see sections III.C and III.H.2). Specific examples are given in Scheme 46.^{74,112}

Scheme 46

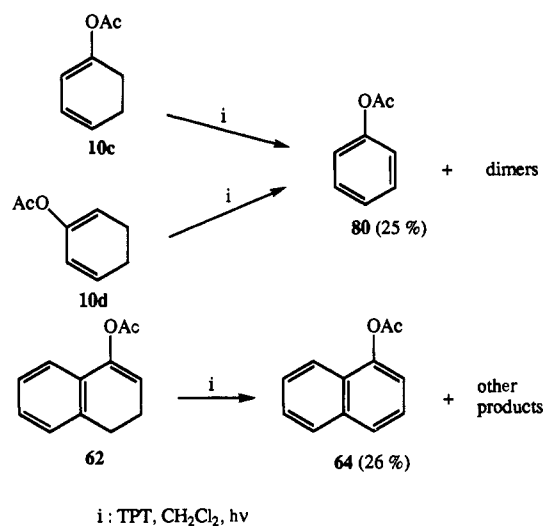

I. Fragmentations

1. Carbon-Carbon Bonds

One of the possible reaction pathways undergone by radical cations is carbon-carbon bond cleavage. This process is of particular interest in the framework of free radical and carbocation chemistry, since it allows the simultaneous generation of both types of reactive intermediates in a given reaction system.

The first report on the PET fragmentation of aralkyl ketones using TPT as photosensitizer¹¹⁸ demonstrated that the radical cations of 3-phenylpropiophenones undergo C-C bond cleavage in solution. The results are presented in Scheme 47, using the 3,3-diphenyl derivative as prototype.

Scheme 47

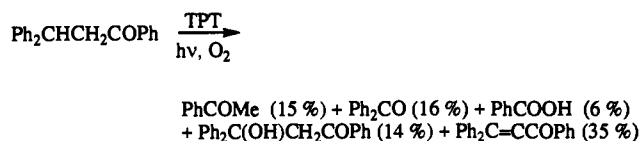

More recently, a related study has been performed on aralkyl ketones and aldehydes with a two-carbon aliphatic chain.¹¹⁹ In spite of the high oxidation potentials of the substrates (typically between 2.2 and 2.4 V *vs* SCE), the strong electron-accepting ability of TPT in its singlet excited state allowed generation of the corresponding radical cations and their subsequent fragmentation. By contrast, DCA was not able to act as PET sensitizer in these reactions. For instance, irradiation ($\lambda > 360$ nm) of a solution of 1,2,2-triphenylethanone (50 mM) and TPT (5 mM) in methylene chloride during 3 h resulted in the formation of benzophenone (66%), benzoic acid (22%) and benzoyl fluoride (54%). These results have been explained through the intermediacy of diphenylmethyl/benzoyl radical ion pairs (Scheme 48).

When the photosensitizer was TP⁺PF₆⁻, the yield of benzoic acid was higher (59%) and less benzoyl fluoride was obtained (11%). The use of TP⁺ClO₄⁻ resulted in a better yield of benzoic acid (66%), due to the lack of a fluorine source.

In the case of tetrakis(4-methylphenyl)ethanone (81), laser-flash photolysis experiments afforded direct evi-

Scheme 48

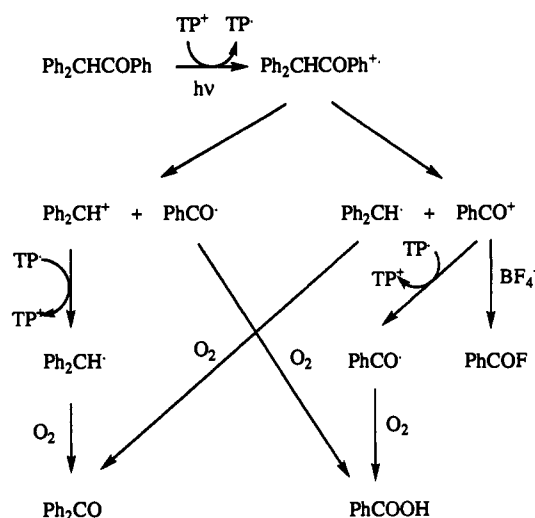

dence for the occurrence of electron transfer to excited TPT and for the direction of subsequent bond cleavage in the radical cation. The transient spectra showed two absorption bands at 455 and 550 nm.¹¹⁹ The former was assigned to tris(4-methylphenyl)methyl cation (82)¹²⁰ and the latter to the pyranyl radical (Scheme 49), on the basis of their coincidence with the reported

Scheme 49

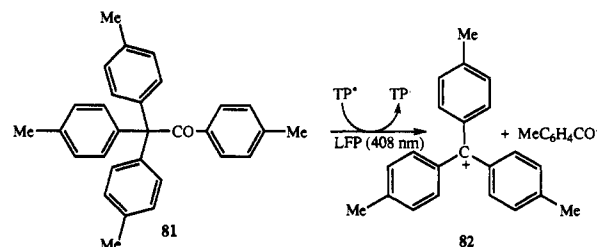

spectra. Measurements of rate constants for carbon-carbon cleavage using different TP⁺ salts, under a variety of experimental conditions, evidenced that this process occurs through a S_N1-type mechanism.¹²¹

Likewise, LFP of TPT in the presence of di(4-methoxyphenyl)acetaldehyde (83) gave transient spectra with two bands at 510 and 550 nm.¹²² The former was assigned to di(4-methoxyphenyl)methyl cation (84), while the latter was assigned to a superposition of the radical cation of the starting aldehyde and pyranyl radical (Scheme 50). The formation of a similar anisyl

Scheme 50

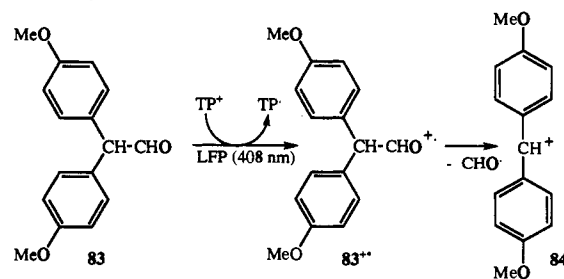

cation has been reported in the TPT-photosensitized reactions of 4-methoxybenzyl alcohol via Lewis acid catalysis.³¹

An analogous result was obtained with 2,4,6-triphenylthiapyrylium tetrafluoroborate as sensitizer, but in this case the intensity of the 550-nm band was much lower, owing to the lack of absorption of the thiapyryl radical at this wavelength. Conversely, LFP of DCA in the presence of the aldehyde led to detection of the radical cation of the latter (550 nm) and $\text{DCA}^{\cdot-}$,¹²³ but no cleavage to the cation (500–510 nm) was observed to take place. Furthermore, addition of LiBF_4 favored carbon-carbon bond rupture in the DCA-photosensitized reaction. This result was attributed to the nucleophilicity of the tetrafluoroborate anion.

Another group of compounds where carbon-carbon bond cleavage occurs upon PET activation with TPT is that of cyclopropane derivatives. Thus, 1-acetoxy-1,2-diphenylcyclopropane underwent oxidative ring opening, to give an unsaturated ketone and a β -acetoxy carbonyl compound (Scheme 51).¹²⁴

Scheme 51

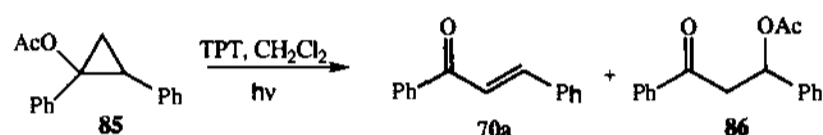

Bicyclo[2.1.0]pentanes have attracted considerable attention as PET donors, in connection with the mechanism of denitrogenation of the related azoalkane radical cations (see section III.I.3).^{125–128} Thus, the TPT-photosensitized rearrangement of housanes (Scheme 52)¹²⁵ has provided valuable information

Scheme 52

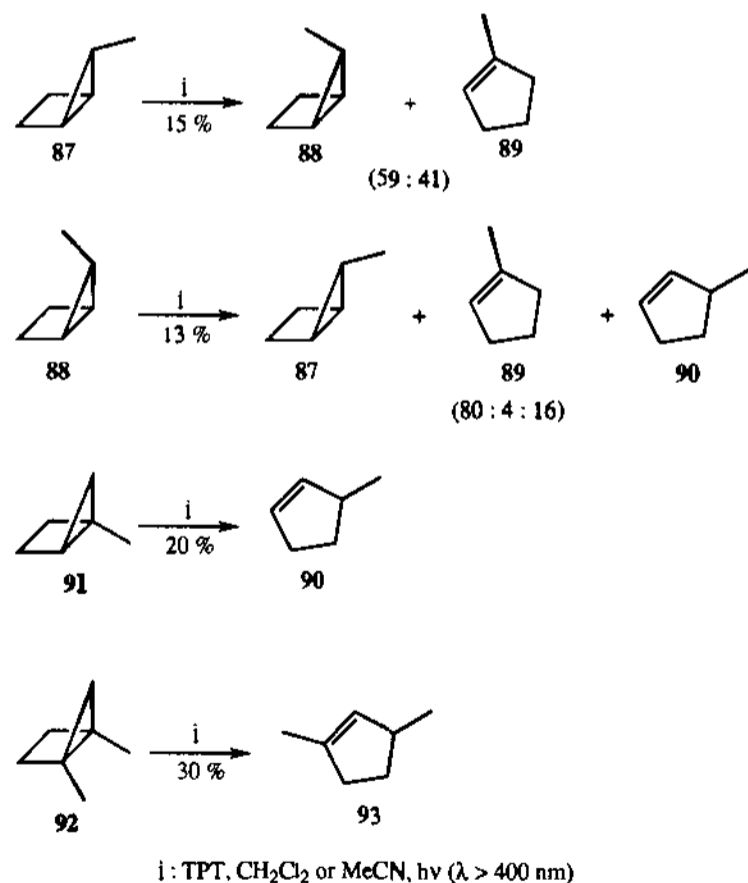

related to the nature of the intermediates involved in the reactions of 2,3-diazabicyclo[2.2.1]oct-2-enes under analogous conditions.

The product distributions obtained with the *syn*- and *anti*-5-methyl derivatives 87 and 88 revealed a remarkable stereochemical memory effect, since the rearrangement to methylcyclopentenes involved preferential 1,2-migration of the *syn* substituent (Me or H).¹²⁹

The pathways responsible for ring inversion and stereoselective olefin formation are shown in Scheme 53.

Scheme 53

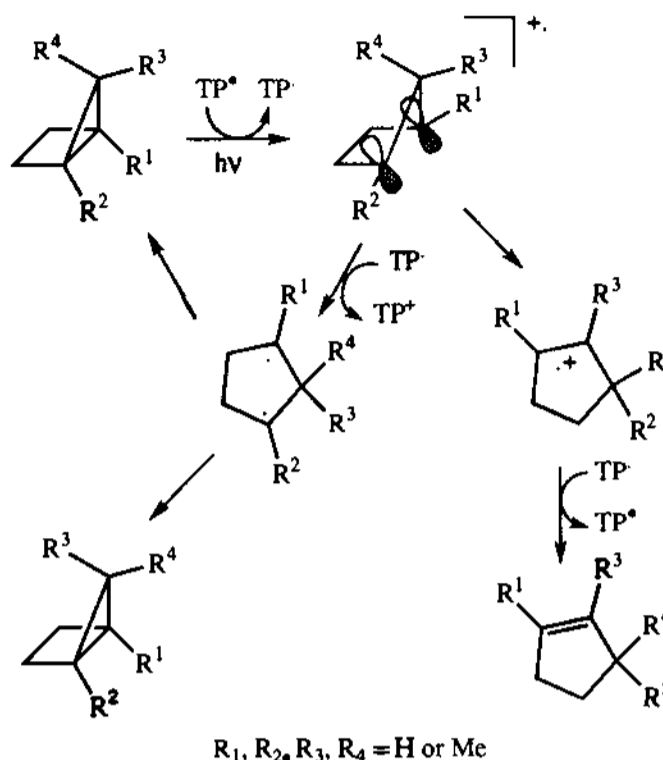

The stereoelectronic factors influencing the migratory aptitude of substituents at position 5 in the puckered 1,3-radical cation are discussed in section III.I.3, together with the stereochemical aspects of TPT-photosensitized azoalkane denitrogenation. A key piece of evidence was obtained by direct ESR detection, which established that the 1,3-diyl radical cations initially formed after radiolytic oxidation of the bicyclopentanes in a CF_3CCl_3 matrix (80–90 K) rearranged stereoselectively to the cyclopentene radical cations.¹²⁹ Further examples of the TPT-sensitized PET reactions of cyclopropane derivatives are illustrated in Scheme 54.^{127,128}

Scheme 54

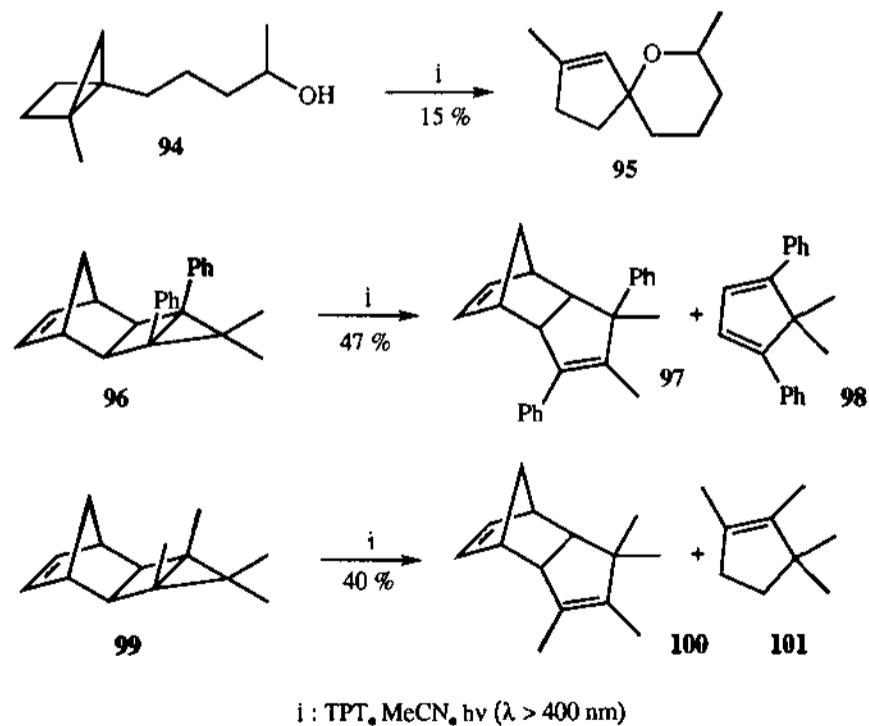

Besides aralkyl ketones or aldehydes and cyclopropane derivatives, some other compounds have been shown to undergo carbon-carbon bond cleavage upon TPT-sensitized photolysis. For instance, PET fragmentation of 4-acetoxy-2-benzyl-2-methylbenzopyran (102) (Scheme 55) afforded toluene, benzaldehyde, 1,2-

Scheme 55

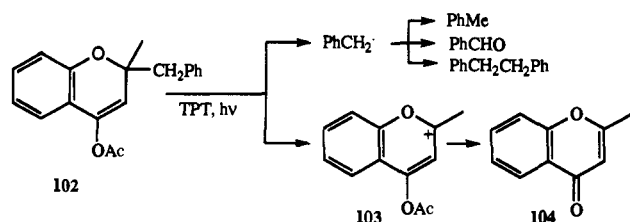

diphenylethane, and 2-methylchromone.¹³⁰ This can be explained by cleavage of the bond linking C₂ with the benzyl substituent, to give 4-acetoxybenzopyrylium ion (103) plus benzyl radical.

Interestingly, fragmentation of the radical cation in the gas phase (MS) followed the same pattern, as evidenced by the fact that the only two peaks with relative intensities higher than 10% were those corresponding to the 4-acetoxybenzopyrylium cation (*m/z* 203, 13%) and protonated 2-methylchromone (*m/z* 161, 100%).

Another interesting example is the TPT-photosensitized carbon-carbon cleavage of triphenylmethane. The initially formed radical cation (detected as transient absorptions at 480 and 700 nm) underwent a rapid deprotonation to the triphenylmethyl radical. Trapping of the latter intermediate by oxygen and subsequent breaking of the resulting peroxy radical led to a mixture of benzophenone and phenol.¹³¹

2. Carbon-Oxygen Bonds

The TPT-photosensitized rearrangement of oxiranes to carbonyl compounds is included in this section because it formally involves a carbon-oxygen bond cleavage. However, the mechanism of this reaction is not well established, and it could involve [1,2] sigmatropic shifts of the substituents at the radical cation stage. The rearrangement of the norbornene-derived substrate 105 is shown in Scheme 56.¹³²

Scheme 56

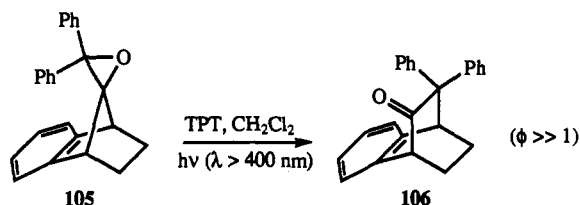

Tris(4-methoxyphenyl)methyl tetrafluoroborate was also efficient as PET sensitizer, but TP⁺ClO₄⁻, TP⁺Cl⁻, and DCA were not able to promote this rearrangement. The above observations led to the conclusion that the presence of tetrafluoroborate anion is essential for the reaction.

Since the oxirane (*E*_{D⁺⁺/D} = 2.07 V *vs* SCE) was an efficient quencher of the TPT fluorescence and, in contrast, small amounts of 1,2,4,5-tetramethoxybenzene (*E*_{D⁺⁺/D} = 0.81 V *vs* SCE) completely inhibited TPT-mediated ketone formation, an electron-transfer step was thought to be involved as primary process.

1,1,2,2-tetraphenylethylene oxide (107) was markedly reluctant to undergo rearrangement, in spite of its ability to quench TPT fluorescence. However, *trans*-stilbene oxide was converted into diphenylacetaldehyde (Scheme 57).¹³²

Scheme 57

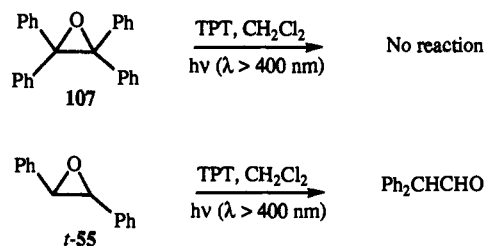

We have observed that *cis*-stilbene oxide also affords diphenylacetaldehyde as a major product; however, an unexpected result was isolation of 1,2-diphenylethanone in a small amount (Scheme 58).¹³³

Scheme 58

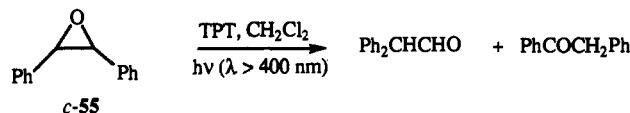

The latter is also a rearrangement product (H migration instead of phenyl migration), and its formation indicated a certain degree of steric control, since it was only observed in the case of the *cis*-oxirane. The mechanistic details of this interesting observation are currently under study.

The selective cleavage of the C_β-O bonds of chalcone epoxides 108 photosensitized by TPT (Scheme 59) has

Scheme 59

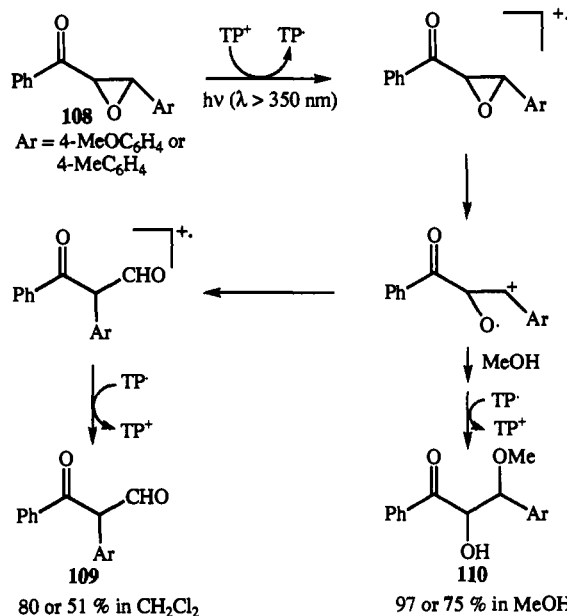

been recently reported.¹³⁴ The major products were β-ketoaldehydes 109 (in CH₂Cl₂) or solvent adducts 110 (in methanol). Quenching experiments with 1,2,4,5-tetramethoxybenzene, 1,4-dimethoxybenzene, and 1,3,5-trimethoxybenzene showed that the product yields increased with increasing oxidation potential of the quencher, supporting an electron-transfer mechanism.

In contrast with previous findings on related compounds (see above),¹³² TP⁺ClO₄⁻ was also found to be an efficient sensitizer to achieve ring opening of chalcone epoxides.¹³⁴

3. Carbon-Nitrogen Bonds

The TPT-photosensitized denitrogenation of azoalkanes via the corresponding radical cations has been

extensively investigated.^{125-129,135,136} In acetonitrile solution, 1,1'-azoadamantane was efficiently converted into *N*-acetyl-1-aminoadamantane, which is clearly the Ritter product derived from solvent trapping of the 1-adamantyl cation (Scheme 60).¹³⁵

Scheme 60

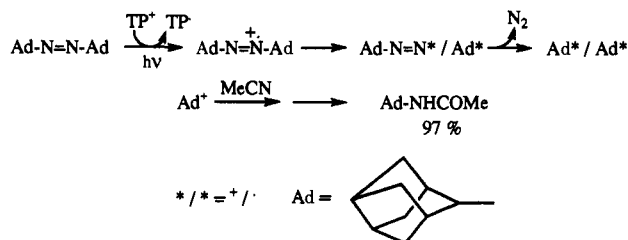

Excited TPT was also found to produce oxidative nitrogen extrusion from tricyclic azoalkanes 111, 114, and 117 (Scheme 61).¹³⁵ In these reactions, two types

Scheme 61

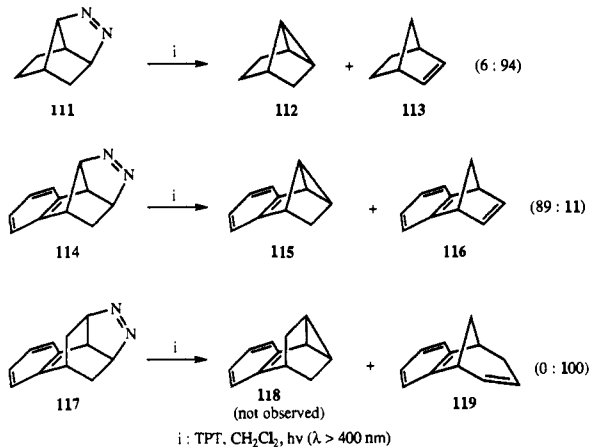

of products were formed cyclopropane derivatives and rearranged olefins.

The above results were rationalized through the intermediacy of 1,3-radical cations. Back-electron transfer would lead to the corresponding biradicals and subsequently to cyclopropanes, while Wagner-Meerwein rearrangements would produce the observed olefins. This is illustrated in Scheme 62, taking a

Scheme 62

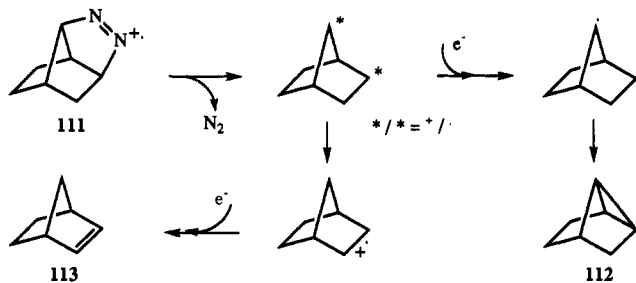

representative tricyclic azoalkane 111 as prototype.

A rather systematic study has been performed on methyl-substituted 2,3-diazabicyclo[2.2.1]hept-2-ene (DBH). The results obtained upon TPT-photosensitized denitrogenation are summarized in Scheme 63.

In all cases, bicyclopentanes and cyclopentenes were obtained as products. The former would be associated to back-electron transfer at the 1,3-diyl radical cation

Scheme 63

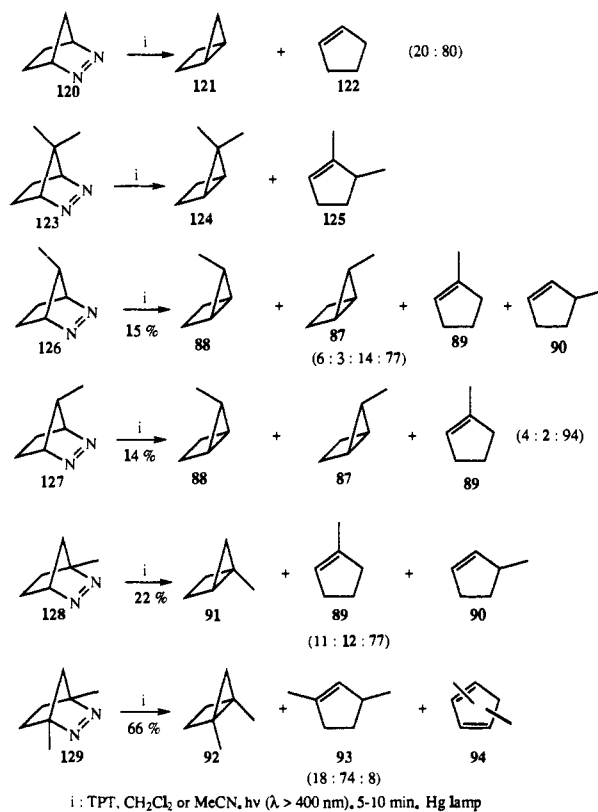

stage, while the latter would be the consequence of 1,2-H or -Me shift (Scheme 64).

Scheme 64

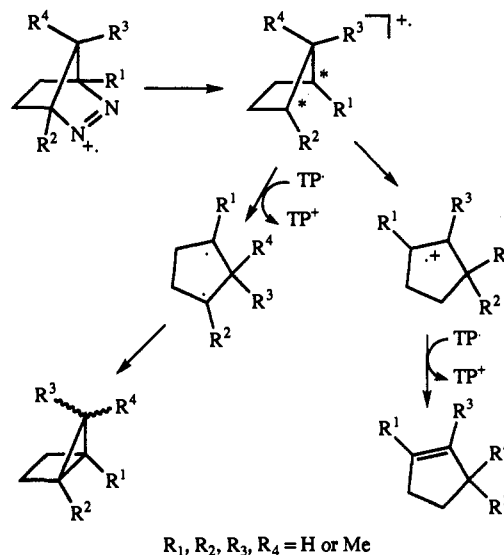

It is worth mentioning that the migratory aptitude of the substituent in the *anti* position to the azo group (R^4) was markedly higher than that of the *syn* substituent (R^3). This suggested that the 1,3-radical cations have a puckered geometry, since in a planar spatial arrangement the same pattern of olefinic products should be expected from *syn*-7-methyl-2,3-diazabicyclo[2.2.1]hept-2-ene as well as from its *anti* isomer. Accordingly, puckered 1,3-radical cations have been inferred from the ESR spectra obtained after γ -irradiation of the closely related bicyclo[2.1.0]pentanes in solid matrix (see section III.I.1). The *anti* substituent

attached to the intervening sp^3 carbon is in good coplanar alignment with the $2p$ orbital lobes of the radical cationic centers, which facilitates its migration (see Scheme 65). Other possibilities are denitrogenation

Scheme 65

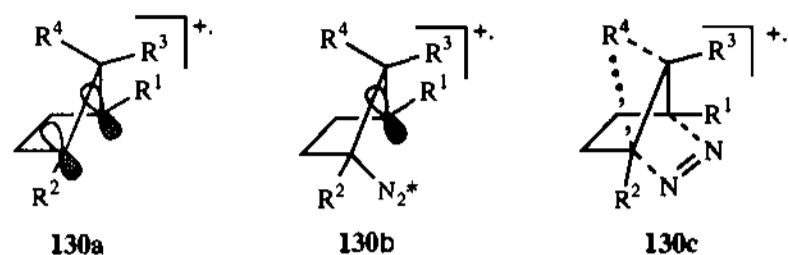

of the diazenyl radical cation with concomitant migration of the antiperiplanar substituent or even concerted nitrogen extrusion from the radical cation of the azo compound with migration of the substituent in the *anti* position to the azo bridge.¹²⁹

Another interesting observation was that the use of 9,10-dicyanoanthracene (DCA) as PET sensitizer instead of TPT led to higher amounts of bicyclopentanes. This has been attributed to the contribution of two factors: (a) an acceleration of the back-electron transfer (BET) to the 1,3-radical cation in the case of DCA, owing to the greater exothermicity of this process (in the normal Marcus region) and (b) the rapid separation of the TPT-derived geminate pairs into free radical ions, due to the lack of Coulombic attraction between the partners (a cation and a radical, instead of a cation and an anion when the sensitizer is DCA). Similar reasons have been argued to explain the fact that, as a general rule, longer reaction times were required in the case of DCA to produce the same degrees of conversion.

The intramolecular nucleophilic trapping of 1,3-radical cations arising from denitrogenation of DBH analogues has been achieved by means of the TPT-sensitized photolysis of the 4-hydroxypentyl-substituted derivative **131** (Scheme 66).¹²⁷

Scheme 66

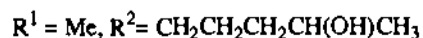
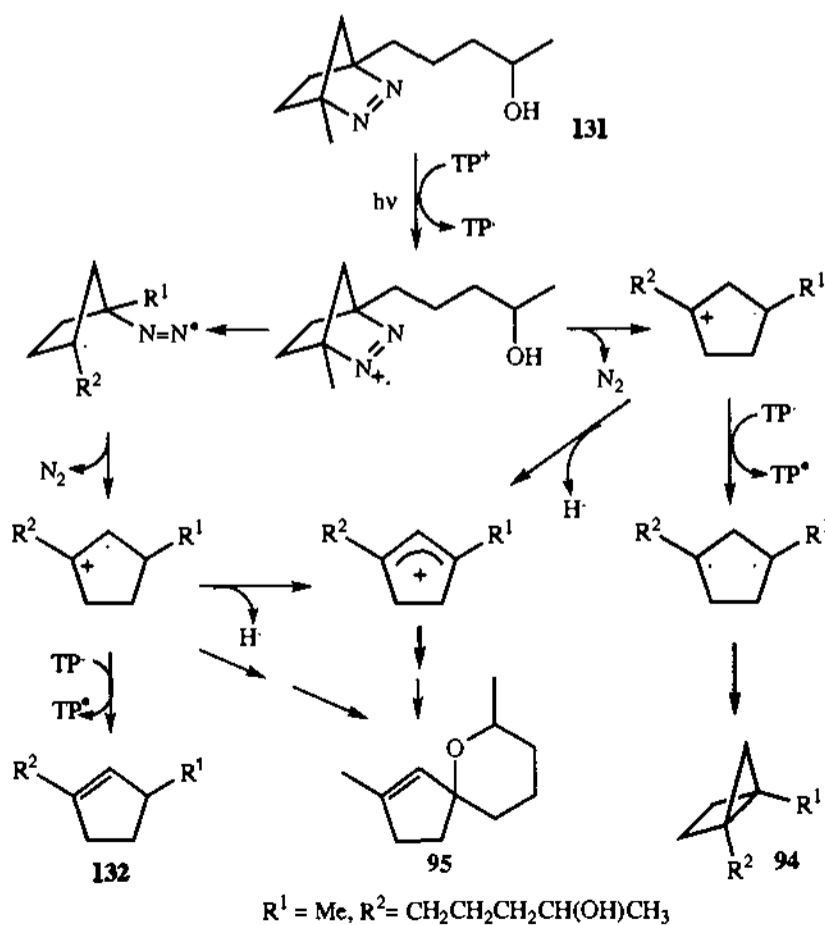

Thus, the formation of spiro ether **95** was taken as an unambiguous evidence for the cyclization of electron-deficient intermediates (*i.e.* radical cations). It was also observed that the addition of biphenyl as a cosensitizer¹²³ strongly altered the product distribution, suppressing almost completely formation of bicyclopentane (BET process) and substantially enhancing the intramolecular trapping leading to the spiro ether. Similar results were obtained with other PET sensitizers such as DCA; however, the reaction was less efficient, and BET to the bicyclopentanes occurred to a higher extent, as above discussed for analogous DBH derivatives.

In view of the intriguing properties of radical cations related to dicyclopentadiene,¹³⁷ the TPT-photosensitized denitrogenation of their azo precursors **133** has been recently studied.¹²⁸ The results obtained and their mechanistic rationalization are summarized in Scheme 67.

Scheme 67

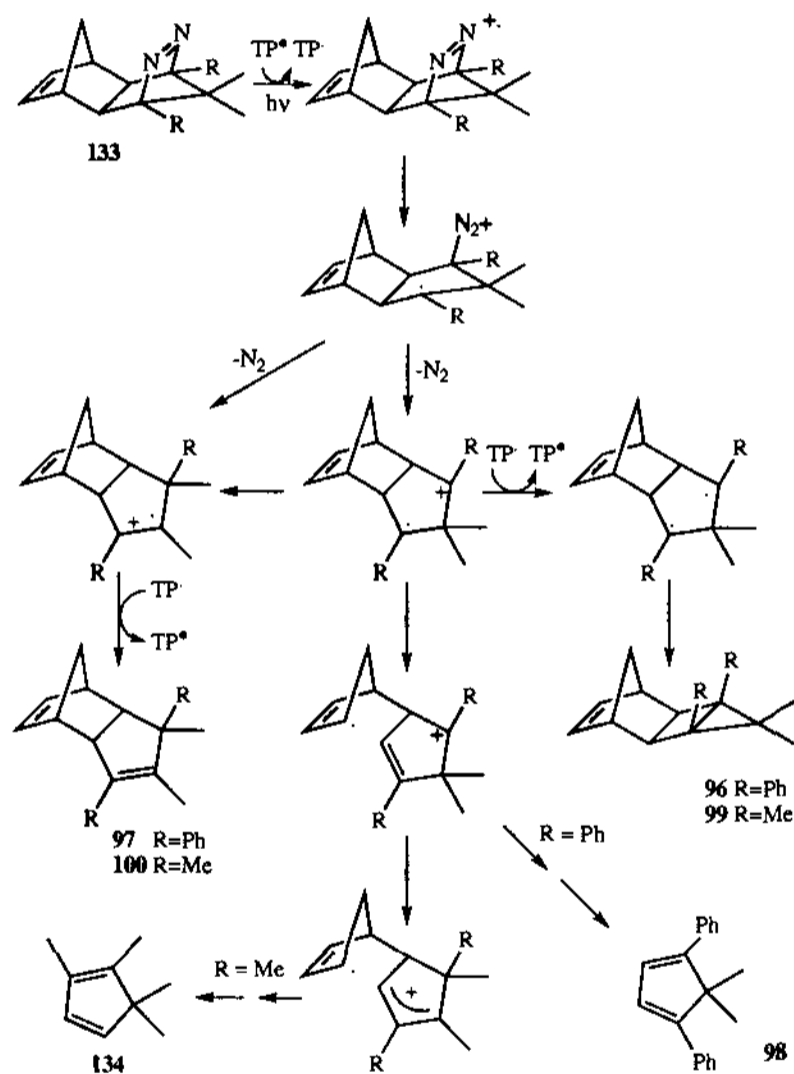

Besides the usually formed cyclopropane derivatives and rearranged olefins, cyclopentadienes arising from cycloreversion occurring at the 1,3-radical cation stage were also obtained. The latter products could not be detected with DCA as PET sensitizer. Thus, the PET reactions of these azoalkanes offer an entry to the interesting chemistry of 1,3-radical cations isomeric of the dicyclopentadiene 1,2-radical cation. While the latter undergo, at most, carbon-carbon cleavage to yield nonvertical intermediates,¹³⁷ the former fragment to unrearranged cyclopentadienes.

4. Carbon-Sulfur Bonds

Thioacetals have been widely used in organic synthesis, either as carbonyl protecting groups or as masked acyl carbanions. Their cleavage to regenerate the

corresponding carbonyl compounds generally involves reaction with soft acids, although in some cases electron transfer-based methodologies have been employed.^{138,139} In this context, PET oxidation using TPT or TP⁺ClO₄⁻ as sensitizer^{140,141} has been found to be a clean and efficient system to achieve the desired thioacetal to carbonyl transformation (see Scheme 68). Since the

Scheme 68

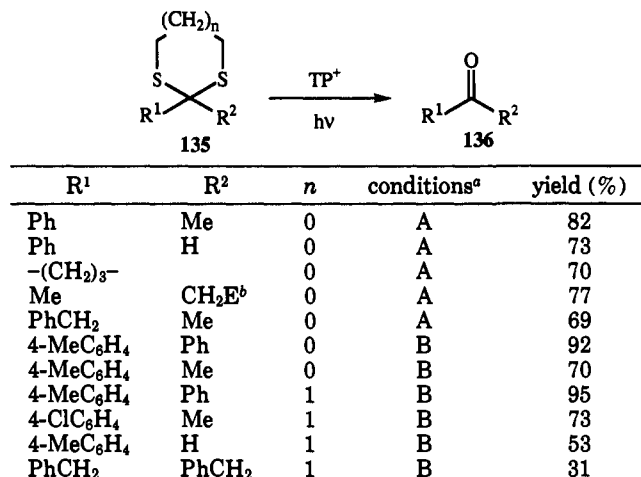

^a (A) thioacetal (1 mmol), TPT (2 mmol), CH₂Cl₂ (300 mL), H₂O (0.3 mL), λ > 300 nm; (B) thioacetal (1 mmol), TP⁺ClO₄⁻ (0.05 mmol), MeCN (50 mL), O₂, λ > 360 nm. ^b E = COOEt.

reaction proceeds under neutral conditions, it can be especially advantageous for polyfunctional compounds containing acid-labile moieties.

Taking into account that the oxidation potential of the substrates 135 are in the range 1.0–1.6 V vs SCE, the feasibility of the electron-transfer step in their TP⁺-sensitized photolytic fragmentation is out of the question. After generation of the radical cations, two different types of carbon–sulfur bond cleavages might in principle take place (Scheme 69): (a) ring opening to

Scheme 69

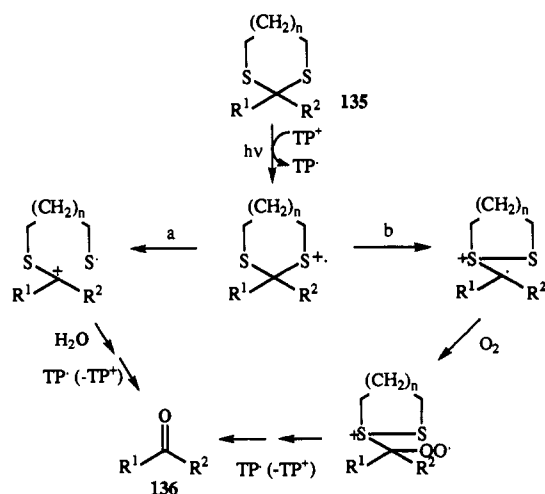

give intermediates possessing a sulfur-centered radical and a carbocationic center or (b) the analogous process leaving the positive charge at the sulfur atom and producing a carbon-centered radical. In view of the observation that carbonyl compounds were not produced in oxygen-free solution, even upon addition of

water,¹⁴¹ route b appears more reasonable. By contrast, the anodic oxidation of thioacetals is thought to proceed following route a.¹³⁹

It is worth mentioning that photooxygenation of 1,3-dithiolanes with 1-cyanonaphthalene as sensitizer afforded only noncleaved sulfoxides.¹⁴² This could be due to the participation of singlet oxygen in the reaction, instead of occurring electron transfer photooxygenation. To check this hypothesis, 2-(4-methylphenyl)-1,3-dithiane (135j) has been submitted to photosensitized oxidation with 2,4,6-tri(4-chlorophenyl)pyrylium perchlorate (TCP⁺ClO₄⁻), DCA, methylene blue (MB), and *meso*-tetraphenylporphyrin (*meso*-TPP).¹⁴³ The results are presented in Scheme 70.

Scheme 70

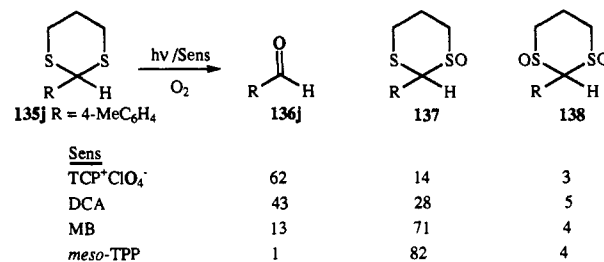

Since singlet oxygen is not involved in the processes photosensitized by pyrylium salts, the carbonyl compounds were clearly produced by oxygenation of the radical cations. On the other hand, the sulfoxide 137 appeared to be a typical singlet oxygen product, as evidenced by the results obtained with MB and, especially, with *meso*-TPP. This suggested that DCA-sensitized photooxygenation of thioacetals involves singlet oxygen mechanism to a considerable extent.

5. Carbon–Metal Bonds

Irradiation of TPT in the presence of tetrabutylstannane, -germane, and -silane produced alkylation of the pyrylium salt at the positions 2 and 4 (Scheme 71).¹⁴⁴

Scheme 71

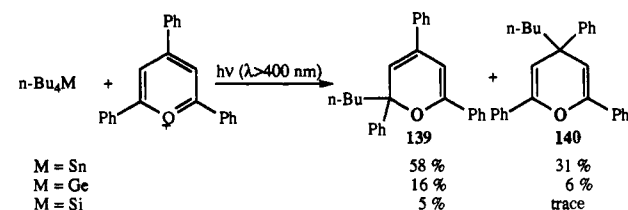

The involvement of an electron-transfer mechanism (see Scheme 72) was inferred from the efficient

Scheme 72

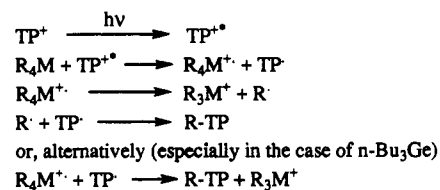

quenching of TPT fluorescence by *n*-Bu₄M at diffusion-controlled rate and also from the thermodynamic feasibility according to the Rehm–Weller equation.

- (17) Wintgens, V.; Pouliquen, J.; Valat, P.; Kossanyi, J.; Canonica, S.; Wild, U. P. *Chem. Phys. Lett.* **1986**, *123*, 282.
- (18) Williams, J. L. R.; Reynolds, G. A. *J. Appl. Phys.* **1968**, *39*, 5327.
- (19) Reynolds, G. A.; Tuccio, S. A.; Petersen, O. G.; Specht, D. P. **1971**, *2*.
- (20) Bastig, D.; Schafer, F. P.; Steyer, B. *Appl. Phys.* **1974**, *3*, 81.
- (21) Rullière, C.; Declémy, A.; Balaban, A. T. *Can. J. Chem.* **1985**, *63*, 191.
- (22) Tripathy, S.; Wintgens, V.; Valt, P.; Toscano, V.; Kossanyi, J.; Bos, F. *J. Lumin.* **1987**, *37*, 149.
- (23) Valat, P.; Tripathi, S.; Wintgens, V.; Kossanyi, J. *New J. Chem.* **1990**, *14*, 825.
- (24) Saeva, F. D.; Olin, G. R. *J. Am. Chem. Soc.* **1980**, *102*, 299.
- (25) Arnett, E. M.; Amarnath, K.; Harvey, N. G.; Cheng, J.-P. *J. Am. Chem. Soc.* **1990**, *112*, 344.
- (26) Ismail, M. I. *Tetrahedron* **1991**, *47*, 1957.
- (27) Arnett, E. M.; Amarnath, K.; Harvey, N. G.; Venimadhavan, S. *J. Am. Chem. Soc.* **1990**, *112*, 7346.
- (28) Arnett, E. M.; Amarnath, K.; Harvey, N. G.; Venimadhavan, S. *J. Am. Chem. Soc.* **1992**, *114*, 221.
- (29) Pragat, F. *Electrochim. Acta* **1976**, *21*, 497.
- (30) Pragat, F.; Ziebig, R. *Electrochim. Acta* **1978**, *23*, 735.
- (31) Martiny, M.; Steckhan, E.; Each, T. *Chem. Ber.* **1993**, *126*, 1671.
- (32) Mattay, J.; Vondenhof, M.; Dening, R. *Chem. Ber.* **1989**, *122*, 951.
- (33) Rehm, D.; Weller, A. *Isr. J. Chem.* **1970**, *8*, 259.
- (34) Farid, S. L. *J. Am. Chem. Soc.* **1991**, *113*, .
- (35) Wintgens, V.; Pouliquen, J.; Simalty, M.; Kossanyi, J.; Justesen, F. K.; Eriksen, J. J. *Photochem.* **1984**, *26*, 131.
- (36) Akaba, R.; Sakuragi, H.; Tokumaru, K. *J. Chem. Soc., Perkin Trans. 2* **1991**, 291.
- (37) Marcus, R. A. *Annu. Rev. Phys. Chem.* **1964**, *28*, 105.
- (38) Hafner, K.; Kaiser, H. *Organic Syntheses*; Wiley: New York, 1973; Collect. Vol. 5, p 1088.
- (39) Meyers, A. I. *Heterocycles in Organic Synthesis*; Wiley: New York, 1974.
- (40) Katritzky, A. R. *Tetrahedron Rep.* **1980**, *36*, 679.
- (41) Pelter, A. *Tetrahedron Lett.* **1981**, *22*, i-ii.
- (42) Parkanyi, C.; Leu, G. J. *Z. Naturforsch. B* **1975**, *30*, 984.
- (43) Babaev, S. N.; Sadouskii, N. A.; Kuz'min, M. G. *Khim. Vys. Energ.* **1984**, *18*, 243; *Chem. Abstr.* **1984**, *101*, 160503y.
- (44) Wintgens, V.; Pouliquen, J.; Kossanyi, J. *Nouv. J. Chim.* **1985**, *9*, 229.
- (45) Tamamura, T.; Yasuba, H.; Okamoto, K.; Imai, T.; Kusabayashi, S.; Mikawa, H. *Bull. Chem. Soc. Jpn.* **1974**, *47*, 448.
- (46) Legoff, E.; Lacount, R. B. *J. Am. Chem. Soc.* **1963**, *85*, 1354.
- (47) van Allan, J. A.; Chang, J. C.; Costa, L. F.; Reynolds, G. A. *J. Chem. Eng. Data* **1977**, *22*, 101.
- (48) Kosower, E.; Linqvist, L. *Tetrahedron Lett.* **1965**, 4481.
- (49) Simons, J. P.; Tatham, P. E. *J. Chem. Soc. A* **1966**, 854.
- (50) Badilescu, S.; Balaban, A. T. *Spectrochim. Acta* **1976**, *32A*, 1311.
- (51) Panov, V. B.; Nekhoroshev, M. V.; Okhlobystiu, O. Y. *Zh. Obshch. Khim.* **1979**, *49*, 234; *Chem. Abstr.* **1979**, *90*, 167849d.
- (52) Conrow, K.; Radlick, P. C. *J. Org. Chem.* **1961**, *26*, 2260.
- (53) Balaban, A. T.; Bratu, C.; Rentea, C. N. *Tetrahedron* **1964**, *10*, 265.
- (54) Bowie, W. T.; Feldman, M. R. *J. Am. Chem. Soc.* **1977**, *99*, 4721.
- (55) Wintgens, V.; Pouliquen, J.; Kossanyi, J.; Heintz, M. *Nouv. J. Chim.* **1986**, *10*, 345.
- (56) Zimmermann, T.; Fischer, G. W.; Reinhardt, M. *Z. Chem.* **1986**, *26*, 400.
- (57) Gard, E.; Balaban, A. T. *J. Electroanal. Chem.* **1962**, *4*, 48.
- (58) Feldman, M.; Winstein, S. *Tetrahedron Lett.* **1962**, 853.
- (59) Pragat, F.; Seydewitz, U. *J. Prakt. Chem.* **1977**, *319*, 952.
- (60) Pragat, F.; Ziedig, R.; Seydewitz, U.; Driesel, D. *Electrochim. Acta* **1980**, *25*, 341.
- (61) Niizuma, S.; Sato, N.; Kawata, H.; Suzuki, Y.; Toda, T.; Kokubun, H. *Bull. Chem. Soc. Jpn.* **1985**, *58*, 2600.
- (62) Kawata, H.; Niizuma, S. *Bull. Soc. Chem. Jpn.* **1989**, *62*, 2279.
- (63) Kawata, H.; Suzuki, Y.; Niizuma, S. *Tetrahedron Lett.* **1986**, *27*, 4489.
- (64) Akaba, R.; Aihara, S.; Sakuragi, H.; Tokumaru, K. *J. Chem. Soc., Chem. Commun.* **1987**, 1262.
- (65) Akaba, R.; Ohshima, K.; Kawai, Y.; Obuchi, Y.; Negishi, A.; Sakuragi, H.; Tokumaru, K. *Tetrahedron Lett.* **1991**, *32*, 109.
- (66) Kuriyama, Y.; Arai, T.; Sakuragi, H.; Tokumaru, K. *Chem. Lett.* **1988**, 1193.
- (67) Akaba, R.; Obuchi, Y.; Shimizu, W.; Ueda, H.; Negishi, A.; Sakuragi, H.; Tokumaru, K. *Stud. Org. Chem.* **1988**, *33*, 91.
- (68) Farid, S.; Shealer, S. E. *J. Chem. Soc., Chem. Commun.* **1973**, 677.
- (69) Mattay, J.; Vondenhof, M.; Dening, R. *EPA Newslett.* **1988**, *32*, 23.
- (70) Dzarava, L. B.; Kataev, V. A.; Klimov, E. S.; Berberova, N. T. *Vysokomol. Soedin., Ser. B* **1985**, *27*, 25.
- (71) Akaba, R.; Sakuragi, H.; Tokumaru, K. *Chem. Phys. Lett.* **1990**, *174*, 80.
- (72) Mattes, S. L.; Farid, S. *J. Am. Chem. Soc.* **1986**, *108*, 7356.
- (73) Mattay, J.; Gersdorf, J.; Mertes, J. *J. Chem. Soc., Chem. Commun.* **1985**, 1088.
- (74) Mlcoch, J.; Steckhan, E. *Angew. Chem., Int. Ed. Engl.* **1985**, *24*, 412.
- (75) Mlcoch, J.; Steckhan, E. *Tetrahedron Lett.* **1987**, *28*, 1081.
- (76) Müller, F.; Mattay, J. *Chem. Rev.* **1993**, *93*, 99.
- (77) Mattay, J.; Trampe, G.; Runsing, J. *Chem. Ber.* **1989**, *121*, 1991.
- (78) Mattes, S. L.; Farid, S. *J. Chem. Soc., Chem. Commun.* **1980**, 126.
- (79) Bauld, N. L.; Bellville, D. J.; Pabon, R.; Chelsky, R.; Green, G. J. *Am. Chem. Soc.* **1983**, *105*, 2378.
- (80) Gieseler, A.; Steckhan, E.; Wiest, O.; Knoch, F. *Synlett* **1990**, *5*, 275.
- (81) Gieseler, A.; Steckhan, E.; Wiest, O.; Knoch, F. *J. Org. Chem.* **1991**, *56*, 1405.
- (82) Wiest, O.; Steckhan, E.; Grein, F. *J. Org. Chem.* **1992**, *57*, 4034.
- (83) Wiest, O.; Steckhan, E. *Tetrahedron Lett.* **1993**, *34*, 6391.
- (84) Wiest, O.; Steckhan, E. *Angew. Chem., Int. Ed. Engl.* **1993**, *32*, 901.
- (85) Okada, K.; Hisamitsu, K.; Mukai, T. *Tetrahedron Lett.* **1981**, *22*, 151.
- (86) Mukai, T.; Sató, K.; Yamashita, Y. *J. Am. Chem. Soc.* **1981**, *103*, 670.
- (87) Hasegawa, E.; Okada, K.; Mukai, T. *J. Am. Chem. Soc.* **1984**, *106*, 6852.
- (88) Okada, K.; Hisamitsu, K.; Miyashi, T.; Mukai, T. *J. Chem. Soc., Chem. Commun.* **1982**, 974.
- (89) Yamashita, Y.; Ikeda, H.; Mukai, T. *J. Am. Chem. Soc.* **1987**, *109*, 6682.
- (90) Searle, R.; Williams, J. L. R.; DeMeyer, D. E.; Doty, J. C. *J. Chem. Soc., Chem. Commun.* **1967**, 1165.
- (91) Herkstroeter, W. G.; Hammond, G. S. *J. Am. Chem. Soc.* **1966**, *88*, 4769.
- (92) Lednev, I. K.; Alfimov, M. V.; Kuriyama, Y.; Arai, T.; Sakuragi, H.; Tokumaru, K. *J. Photochem. Photobiol. A* **1992**, *63*, 201.
- (93) Kuriyama, Y.; Arai, T.; Sakuragi, H.; Tokumaru, K. *Chem. Lett.* **1989**, 251.
- (94) Corma, A.; Fornés, V.; García, H.; Miranda, M. A.; Primo, J.; Sabater, M. J. *J. Am. Chem. Soc.* **1994**, *116*, 2276.
- (95) Sankararaman, S.; Yoon, K. B.; Yabe, T.; Kochi, J. K. *J. Am. Chem. Soc.* **1991**, *113*, 1419.
- (96) Yoon, K. B. *Chem. Rev.* **1993**, *93*, 321.
- (97) Corma, A.; Fornés, V.; García, H.; Miranda, M. A.; Primo, J.; Sabater, M. J. Submitted for publication.
- (98) Adam, W.; Grabowski, S.; Miranda, M. A.; Rübenacker, M. *J. Chem. Soc., Chem. Commun.* **1988**, 142.
- (99) Miyashi, T.; Konno, A.; Takahashi, Y. *J. Am. Chem. Soc.* **1988**, *110*, 3676.
- (100) Nelsen, S. F.; Akaba, R. *J. Am. Chem. Soc.* **1981**, *103*, 2096.
- (101) Clennan, E. L.; Simmons, W.; Almgren, I. W. *J. Am. Chem. Soc.* **1981**, *103*, 2098.
- (102) Nelsen, S.; Teasley, M. F.; Kapp, D. L. *J. Am. Chem. Soc.* **1986**, *108*, 5503.
- (103) Nelsen, S. F. *Acc. Chem. Res.* **1987**, *20*, 269.
- (104) Nelsen, S. F.; Kessel, C. R. *J. Am. Chem. Soc.* **1979**, *101*, 2503.
- (105) Yoshida, Z.; Sugimoto, T.; Yoneda, S. *Tetrahedron Lett.* **1971**, *12*, 4259.
- (106) Eriksen, J.; Foote, C. S.; Praker, T. L. *J. Am. Chem. Soc.* **1977**, *9*, 6455.
- (107) Eriksen, J.; Foote, C. S. *J. Am. Chem. Soc.* **1980**, *102*, 6083.
- (108) Rio, G.; Berthelot, J. *Bull. Soc. Chim. Fr.* **1970**, 1509.
- (109) Manring, L. E.; Eriksen, J.; Foote, C. S. *J. Am. Chem. Soc.* **1980**, *102*, 4275.
- (110) Kwon, B.-M.; Foote, C. S.; Khan, S. I. *J. Org. Chem.* **1989**, *54*, 3378.
- (111) Fox, M. A.; Chen, C.-C. *J. Am. Chem. Soc.* **1981**, *103*, 6757.
- (112) Climent, M. J.; García, H.; Iborra, S.; Miranda, M. A.; Primo, J. *Tetrahedron* **1991**, *47*, 9289.
- (113) Climent, M. J.; Corma, A.; García, H.; Miranda, M. A.; Primo, J. *J. Photochem. Photobiol. A: Chem.* **1991**, *59*, 379.
- (114) Algarra, F.; Baldoví, M. V.; García, H.; Miranda, M. A.; Primo, J. *Monatsh. Chem.* **1993**, *124*, 209.
- (115) Shono, T. *Electroorganic Chemistry as a New Tool in Organic Synthesis*; Springer: Heidelberg, 1984.
- (116) Climent, M. J.; García, H.; Miranda, M. A.; Primo, J. *Tetrahedron* **1987**, *28*, 3613.
- (117) Climent, M. J.; García, H.; Iborra, S.; Miranda, M. A.; Primo, J. *Heterocycles* **1989**, *29*, 115.
- (118) Baldoví, M. V.; García, H.; Miranda, M. A.; Primo, J. *Monatsh. Chem.* **1990**, *121*, 371.
- (119) Akaba, R.; Niimura, Y.; Fukushima, T.; Kawai, Y.; Tajima, T.; Kuragami, T.; Negishi, A.; Kamata, M. *J. Am. Chem. Soc.* **1992**, *114*, 4460.
- (120) Faria, J. L.; Stenken, S. *J. Am. Chem. Soc.* **1990**, *112*, 1277.
- (121) Akaba, R.; Kamata, M.; Sakuragi, H.; Tokumaru, K. *Tetrahedron Lett.* **1992**, *33*, 8105.
- (122) Akaba, R.; Kamata, M.; Kuriyama, Y.; Tokumaru, K. *Chem. Lett.* **1993**, 1157.
- (123) Gould, I. R.; Ege, D.; Moser, J. E.; Farid, S. *J. Am. Chem. Soc.* **1990**, *112*, 4290.
- (124) Algarra, F.; Baldoví, M. V.; García, H.; Miranda, M. A.; Primo, J. *Tetrahedron* **1993**, *49*, 10897.
- (125) Adam, W.; Walter, H.; Chen, G.-F.; Williams, F. *J. Am. Chem. Soc.* **1992**, *114*, 3007.
- (126) Adam, W.; Sahin, C.; Sendelbach, J.; Walter, H.; Chen, G. F.; Williams, F. *J. Am. Chem. Soc.*, in press.
- (127) Adam, W.; Sendelbach, J. *J. Org. Chem.* **1993**, *58*, 5310.
- (128) Adam, W.; Sendelbach, J. *J. Org. Chem.* **1993**, *58*, 5316.

- (129) Adam, W.; Denninge, V.; Finzel, R.; Kita, F.; Platsch, H.; Walter, H.; Zang, G. *J. Am. Chem. Soc.* **1992**, *114*, 5027.
- (130) Jiménez, M. C.; Miranda, M. A.; Soto, J.; Tormos, R. *Tetrahedron*, in press.
- (131) Akaba, R.; Kamata, M.; Itoh, H.; Nakao, A.; Goto, S.; Saito, K.; Negishi, A.; Sakuragi, H.; Tokumaru, K. *Tetrahedron Lett.* **1992**, *33*, 7011.
- (132) Okada, K.; Hasegawa, E.; Mukai, T. *Chem. Lett.* **1983**, 305.
- (133) García, H.; Miranda, M. A.; Sabater, M. J. Unpublished results.
- (134) Hasegawa, E.; Ishiyama, H.; Kashiwazaki, H.; Horaguchi, T.; Shimizu, T. *Tetrahedron Lett.* **1990**, *31*, 4045.
- (135) Adam, W.; Dörr, M. *J. Am. Chem. Soc.* **1987**, *109*, 1570.
- (136) Adam, W.; Miranda, M. A. *J. Org. Chem.* **1987**, *52*, 5498.
- (137) Roth, H. D. *Acc. Chem. Res.* **1987**, *20*, 343.
- (138) Gourcy, J.; Martigny, P.; Simonet, J.; Jeminet, G. *Tetrahedron* **1981**, *37*, 1495.
- (139) Platen, M.; Steckhan, E. *Chem. Ber.* **1984**, *117*, 1679.
- (140) García, H.; Iborra, S.; Miranda, M. A.; Primo, J. *New J. Chem.* **1989**, *13*, 805.
- (141) Kamata, M.; Kato, Y.; Hasegawa, E. *Tetrahedron Lett.* **1991**, *32*, 4349.
- (142) Pandey, B.; Bal, S. Y.; Khire, V. R. *Tetrahedron Lett.* **1989**, *30*, 4007.
- (143) Kamata, M.; Sato, M.; Hasegawa, E. *Tetrahedron Lett.* **1992**, *33*, 5085.
- (144) Kyushin, S.; Nakadaira, Y.; Ohashi, M. *Chem. Lett.* **1990**, 2191.
- (145) Baciocchi, E.; Doddi, G.; Ioele, M.; Ercolani, G. *Tetrahedron* **1993**, *49*, 3793.
- (146) Yamaoka, T.; Koseki, K.; Goto, Y. Belg. Patent BE 897,694; *Chem. Abstr.* **1984**, *100*, 192538j.
- (147) Matsumoto, T.; Minoshima, Y.; Nakachi, O. Jpn. Kokai Tokkyo Koho JP 63 278,903, 1988; *Chem. Abstr.* **1989**, *110*, 213634m.
- (148) Masuhara, E.; Kadoma, Y.; Matsumoto, T.; Komai, T.; Yamada, E.; Nakachi, O.; Irukayama, T. Eur. Patent EP 176,777, 1987; *Chem. Abstr.* **1986**, *105*, 49101j.
- (149) Woods, J.; Streinkraus, W. J.; Rooney, J. M. Eur. Patent EP 190,831, 1985; *Chem. Abstr.* **1986**, *105*, 227875z.
- (150) Koseki, K.; Yamaoka, T.; Tsumoda, T.; Shimizu, S. *Nippon Kagaku Kaishi* **1983**, 798; *Chem. Abstr.* **1983**, *99*, 96743n.
- (151) Mistr, A.; Zahradnik, R. *Collect. Czech. Chem. Commun.* **1973**, *38*, 1668.
- (152) Fico, S. S.; Manthey, J. W. U.S. Patent 3,772,028, 1973; *Chem. Abstr.* **1974**, *80*, 151233f.
- (153) Rooney, J. M. *J. Macromol. Sci., Chem.* **1986**, *23A*, 823.
- (154) Mistr, A.; Vaura, M.; Skoupy, J.; Zahradnik, R. *Collect. Czech. Chem. Commun.* **1972**, *37*, 1520.
- (155) Ledwith, A. *Polym. Prep.* **1982**, *23*, 323.
- (156) Takato, T. Jpn. Kokai Tokkyo Koho JP 60 203,628; *Chem. Abstr.* **1986**, *104*, 110831v.
- (157) Demmler, K.; Ochs, W. Ger. Offen. DE 3,135,636, 1981; *Chem. Abstr.* **1983**, *98*, 199271r.
- (158) Ueno, K.; Tsunoda, T. Jpn. Kokai Tokkyo Koho 74 135,616, 1974; *Chem. Abstr.* **1975**, *83*, 106227h.
- (159) Matsumoto, T.; Irukayama, T.; Nakachi, O.; Yamada, E. Jpn. Kokai Tokkyo Koho JP 62 45,509, 1987; *Chem. Abstr.* **1987**, *108*, 64915n.
- (160) Woods, J. G.; Rooney, J. M. U.S. Patent 4,675,270; *Chem. Abstr.* **1988**, *108*, 29436f.
- (161) Ishii, K.; Sato, M.; Anzai, K.; Murata, T. Jpn. Kokai Tokkyo Koho JP 62 161,860, 1987; *Chem. Abstr.* **1987**, *107*, 200643b.
- (162) Adin, A.; Fleming, J. C. U.S. Patent 4,201,588, 1974; *Chem. Abstr.* **1981**, *94*, 74758r.
- (163) Saito, C.; Yamamuro, S.; Sakai, K.; Ohta, M. Jpn. Kokai Tokkyo Koho 78 77,614, 1978; *Chem. Abstr.* **1979**, *90*, 160126g.
- (164) Saito, C.; Yamamuro, S.; Sakai, K.; Ohta, M. Jpn. Kokai Tokkyo Koho 78 77,615, 1978; *Chem. Abstr.* **1979**, *90*, 79132j.
- (165) Kurita, Y. Ger. Offen. 2,824,928, 1978; *Chem. Abstr.* **1979**, *90*, 178195p.
- (166) Markiewitz, N.; Stolle, T.; Pragst, F. Ger. Patent (East) 189,476, 1980; *Chem. Abstr.* **1982**, *95*, 178671r.
- (167) Markiewitz, N.; Bandlow, M.; Stolle, T.; Pragst, F. Ger. Patent (East) 138,447, 1979; *Chem. Abstr.* **1980**, *93*, 16923j.
- (168) Petropoulos, C. C.; Reynolds, G. A.; van Allan, J. A. Ger. Offen. 2,829,751, 1979; *Chem. Abstr.* **1979**, *91*, 174422h.
- (169) Regan, M. T.; Staudenmeyer, W. J.; van Allan, J. A.; Yoerger, W. E. Ger. Offen. 2,822,761, 1978; *Chem. Abstr.* **1979**, *90*, 178156b.
- (170) Petropoulos, C. C.; Reynolds, G. A.; van Allan, J. A. *Res. Discl.* **1977**, *163*, 14; *Chem. Abstr.* **1978**, *88*, 43703r.
- (171) Fox, C. J. Ger. Offen. 2,631,629, 1976; *Chem. Abstr.* **1977**, *86*, 163620a.
- (172) Reynolds, G. A.; van Allan, J. A.; Contois, L. E. U.S. Patent 3,938,994, 1974; *Chem. Abstr.* **1976**, *84*, 152236d.
- (173) Reynolds, G. A.; van Allen, J. A.; Contois, L. E. U. S. Patent 904, 032, 1972; *Chem. Abstr.* **1973**, *78*, 65265v.
- (174) Klimov, E. S.; Bumber, A. A.; Monastyrskaya, V. I.; Kataev, V. A.; Chigorina, T. M.; Okhlobystiu, O. Y. *Elektron Org. Mater.* **1985**, *276*; *Chem. Abstr.* **1976**, *107*, 67841w.
- (175) Churkina, V. A.; Mel'nichuba, L. A.; Ivanova, T. N.; Rumyantsev, B. M.; Balabanov, E. I.; Kovshev, E. I. *Elektron Org. Mater.* **1985**, *343*; *Chem. Abstr.* **1987**, *107*, 167272f.
- (176) Okazaki, M.; Yamaguchi, A.; Kozima, A.; Sasaki, M. Ger. Offen. 2,717,007, 1987; *Chem. Abstr.* **1978**, *88*, 43755j.
- (177) Emoto, K.; Futaki, K. Jpn. Kokai Tokkyo Koho 77 52,637, 1977; *Chem. Abstr.* **1978**, *88*, 97395k.
- (178) Demidov, K. B.; Gaziev, Z. A.; Akimov, I. A. *Zh. Nauchn. Prikl. Fotogr. Kinematogr.* **1983**, *28*, 380; *Chem. Abstr.* **1984**, *100*, 15227m.
- (179) Okhlobystiu, O. Y.; Klimov, E. S.; Bumber, A. A.; Monastyrskaya, V. I.; Kataev, V. A.; Chigorina, T. M. *Zh. Prikl. Khim.* **1984**, *57*, 348; *Chem. Abstr.* **1984**, *100*, 175747j.
- (180) Klimov, E. S.; Gassieva, E. U.; Okhlobystiu, O. Y. *Zh. Nauchn. Prikl. Fotogr. Kinematogr.* **1984**, *29*, 136; *Chem. Abstr.* **1984**, *100*, 183064z.
- (181) Monroe, B. M.; Weed, G. C. *Chem. Rev.* **1993**, *93*, 435.
- (182) Law, K.-Y. *Chem. Rev.* **1993**, *93*, 449.