

## Study on the Bleaching Mechanism of Indigo-carmin catalyzed by Laccase Using EFA and MCR-ALS Methods

Hua LI<sup>1\*</sup>, Fang ZHANG<sup>1</sup>, W. KESSLER<sup>2</sup>, R. W. KESSLER<sup>2</sup>

<sup>1</sup>Institute of Analytical Science, Northwest University, Xi'an 710069

<sup>2</sup>Institute of Applied Research, Reutlingen University of Applied Sciences, Alteburgstrasse 150, D-72760, Reutlingen, Germany

**Abstract:** The bleaching of indigo-carmin catalyzed by laccase was monitored on-line by UV/Vis spectroscopy. The resulted data were analyzed by evolving factor analysis (EFA) and multivariate curve resolution (MCR), and the reaction mechanism was proposed.

**Keywords:** Chemometrics, process analysis, EFA, MCR-ALS.

Modern chemical processes are capable of generating and processing huge amounts of process data, especially with the increased use of chemical analyzers and instrumentation. Extracting the significant information from the data produced by modern instrumentation and describing the evolution of a chemical process are important for both practical and economic reasons. The application of chemometrics tools plays an important role in process analysis<sup>1</sup> and seeks to provide additional insights into the chemical process through monitoring, modeling, and control. Multivariate curve resolution (MCR)<sup>2,3</sup> methods are a group of techniques which intend the recovery of the response profiles (spectra, pH profiles, time profiles, elution profiles...) of more than one component in an unresolved and unknown mixture obtained from evolutionary processes. In this work, the multivariate curve resolution with alternating least square methods (MCR-ALS)<sup>2,3</sup> using the initial estimates provided by evolving factor analysis (EFA)<sup>4,5</sup> are applied to extract the useful chemical information from reaction monitoring data and deduce the reaction mechanism. The advantage of MCR is that it does not rely on the initial proposal of a specific model but estimates directly the changes in data<sup>5</sup>.

Indigo-carmin is a blue synthetic coal tar dye. It is one cause of dermatitis because of positive patch test reactions to both commercial and purified samples of it. It is harmful if swallowed, inhaled or absorbed through the skin. Technological systems for the control of release of such organic pollutants is necessary for protecting the ecosystem from being polluted. In this work, a biological method was developed, which uses laccase as catalyst for chlorine free bleaching of indigo carmin. The bleaching monitored on-line by UV/Vis spectroscopy and the data were studied by the above

---

\*E-mail: huali@nwu.edu.cn

chemometrics method. The reasonable reaction mechanism was deduced.

## Theory

### *Evolving factor analysis*

Evolving factor analysis has been used to assess peak purity and to resolve overlapped peaks<sup>5,6</sup>. In this work, EFA is used to obtain the initial estimation of the concentration profiles for ALS. After the reaction, a data matrix  $D(m \times n)$  is obtained, where the  $m$  rows are spectra measured at regular time intervals and the  $n$  columns are absorption recorded at different wavelengths. EFA examines changes in the eigenvalues during the process in forward and backward directions. In this way, the information about the appearance and the disappearance of the components is obtained. It is assumed that the first component appearing will be the first to disappear and the  $i$ th component will be the  $i$ th to disappear. Thus a concentration window<sup>4</sup> is generated for the  $i$ th component from the point where the rank of  $D$  rises to  $i$  in the forward calculation to the point in the backward calculation where the rank rises to  $N+1-i$ . Outside this window the concentration is known to be zero. Once the number of significant contributions is deduced, their initial estimation of the concentration profiles can be obtained. Here, this number is determined if the resulting resolution is reasonable by using it.

### *Alternating least square optimization*

From the results of evolving factor analysis, the window or range of existence of each component as well as its concentration profile can be obtained. These concentration profiles are used as initial values in a constrained alternating least-squares (ALS)<sup>2,3,7</sup> optimization procedure. It consists of two parts:

- (a) An estimation of the unknown species spectra is obtained by least squares:

$$S = C^+ D^*$$

Where  $D^*$  is the reproduced data matrix for the considered number of species and  $C^+$  is the pseudoinverse of  $C$ . The matrix  $S$  gives the current least-squares estimation of the unit spectra. The UV-Vis absorptivities must be positive. This constraint is applied accordingly during the least-squares optimization.

- (b) A new estimation of the concentration profiles is obtained by least-squares:

$$C = D^* S^+$$

Where now  $S^+$  is the pseudoinverse of the  $S$  matrix. In this case, the concentrations derived from the equation are constrained to be positive. Steps a and b are repeated until the data matrix  $D$  is well explained within experimental error.

## Experimental

Indigo-carmin was purchased from SIGMA. Stock solution of it containing 125 ug/L was prepared and was adjusted to pH 4. Laccase activity was 200 LACU/g. The temperature of experiment was controlled at 40°C.

Figure 1 The instrument of experiment

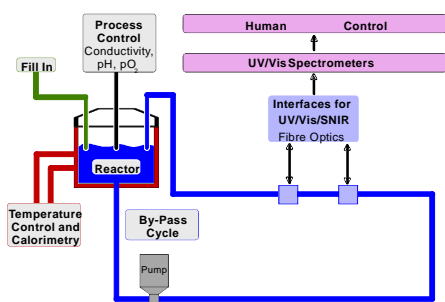

Figure 2 Three-dimensional plot of spectrum of indigo-carmin+laccase reaction system

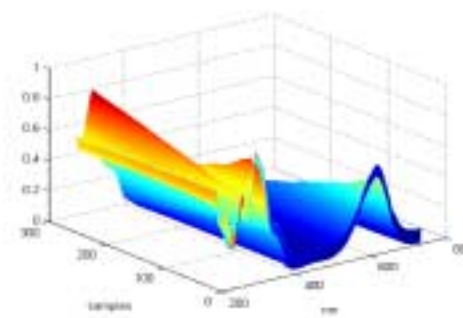
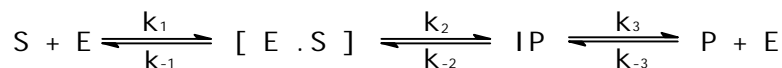

Figure 1 shows the instrument of this experiment. 700 mL stock solution of indigo-carmin was filled into the reactor, then 1.05 g laccase (300 LACU/L) was added. After 6.02 min, the reaction was finished. Spectra were acquired in the range 190-750 nm at regular intervals of 5 s during the bleaching process and wavelengths were taken every 2 nm in the whole range.

### Results and Discussion

Figure 3 is a plot of the initial concentration from evolving factor analysis when the number of factors considered to be 4. This initial concentration of the reaction system is used to start a nonnegative alternating least-squares optimization. The optimized concentration profiles and unit spectra are shown in Figure 4.

The concentration profiles suggest that immediately after starting the reaction, the substrate curve goes to near zero, while a charge-transfer complex is formed and reaches its maximum of value. Shortly after being at its peak, the charge-transfer complex curve goes down and converts into an intermediate product (IP). All the above changes take place during the first 10 samples. The intermediate product starts the bleaching process and slowly converts into the final product. The proposed mechanism might be:



Where S is the substrate, here it denotes the indigo-carmin, E the enzyme laccase, [E.S] a charge-transfer complex, IP is an intermediate product and P the final product of the reaction.

### Conclusion

The advantage of the above method compared to the classical methods is that it does not rely on the initial proposal of a specific kinetic model but estimates directly the changes in concentration, extracts the number of an analyte present and calculates pure component spectra, which are chemically meaningful. This method allows the deduction of reasonable mechanism of a reaction.

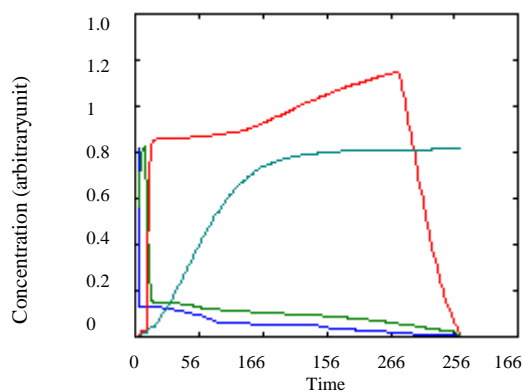
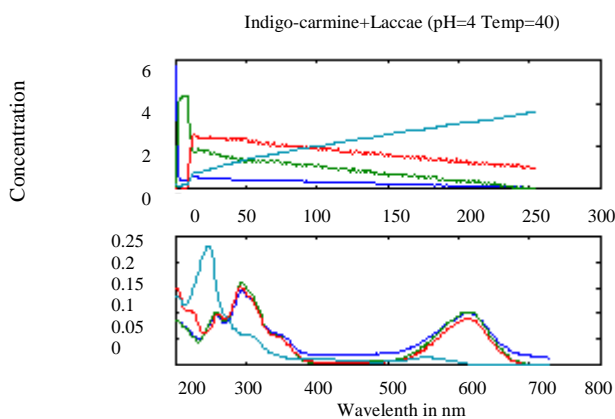
**Figure 3** Initial concentration changes estimated by evolving factor analysis**Figure 4** Concentration profiles and pure spectra of indigo-carmin + laccase reaction system

### Acknowledgment

The work was supported by the National Natural Science Foundation of China [Grant No. 20075021], and visiting grant of Reutlingen University of Applied Sciences in Germany.

### References

1. J. B. Callis, D. L. Illman, B. R. Kowalski, *Anal. Chem.*, **1987**, 59, 624A.
2. R. Tauler, D. Barcelo, *Trends in Analytical Chemistry*, **1993**, 8, 319.
3. R. Gargallo, R. Tauler, F. Cuesta-Sanchez, D. L. Massart, *Trends in Analytical Chemistry*, **1996**, 7, 279.
4. M. Maeder, *Anal. Chem.*, **1987**, 59, 527.
5. H. Gampp, M. Maeder, Ch. Meyer, A.D. Zuberbuhler, *Talanta*, **1985**, 32, 1133.
6. R. Tauler, G. Durand, D. Barcelo, *Chromatographia*, **1992**, 5/6, 244.
7. A. de Juan, Y. Vander Heyden, R. Tauler, D. L. Massart, *Anal. Chim. Acta*, **1997**, 346, 307.

Received 17 June, 2002