

NOVEL MECHANISTIC ASPECTS OF THE 4-ACYL- $\beta$ -LACTAM FORMATION FROM 1,2-IMINOKETONES

\*

Benito Alcaide, Gema Dominguez, Joaquín Plumet, and Miguel A. Sierra  
 Universidad Complutense, Facultad de Química, Departamento de Química  
 Orgánica. 28040-Madrid, Spain

**Abstract** — On the basis of chemical and stereochemical evidence the course of the formation of 4-acyl- $\beta$ -lactams from 1,2-iminoketones by reaction with the acyl chloride/Et<sub>3</sub>N system or with the preformed ketene is discussed.

The cycloaddition reactions of 1,2-iminoketones 1 with acyl chlorides 2 in the presence of Et<sub>3</sub>N afford 4-acyl- $\beta$ -lactams 3. When R<sup>3</sup> is achiral only one diastereomer is observed in all cases.

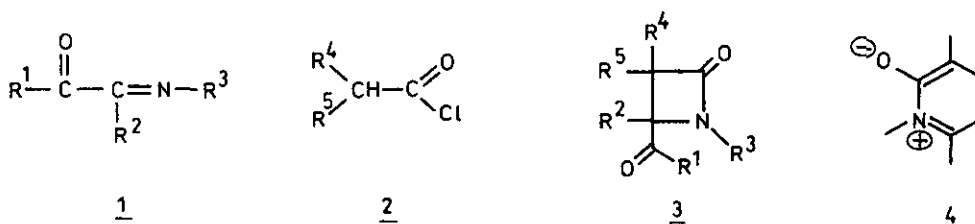

In the reaction of imines with the acyl chloride/Et<sub>3</sub>N system there is evidence that the zwitterion 4 is an intermediate of the reaction. Conrotatory electrocyclic ring closure leads to the  $\beta$ -lactam. On starting from the acyl chloride/Et<sub>3</sub>N system and from the pre-formed ketene is the same zwitterion formed? Reaction of diphenylacetyl chloride/Et<sub>3</sub>N with iminoketones 5 and 6 yields  $\beta$ -lactams 7 and 8 in the 1'R4S-1'S4R/1'R4R-1'S4S ratios of 1.32 and 0.95 for 7 and 8, respectively. Diastereomeric ratios of 1.32 (for 7) and 0.99 (for 8) are found in the reaction of diphenyl ketene with the same iminoketones.

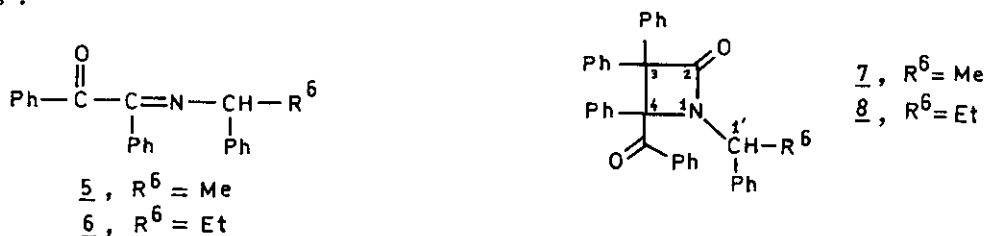

On the basis of this results it seems that the same zwitterion is formed starting from the acyl chloride/Et<sub>3</sub>N system and from the pre-formed ketene.

The zwitterionic intermediate may be originated via two different pathways from the acyl

chloride/Et<sub>3</sub>N system. The acyl chloride may either be converted to the corresponding ketene before combining with the imine or may first react with the imine to give 9 which is then deprotonated to 10. The reactions of iminoketones 1 with phenylacetyl chloride in the same conditions of formation of β-lactams but in the absence of Et<sub>3</sub>N afford β-lactams 3 identical to those obtained in the



presence of Et<sub>3</sub>N in good yield (Table 1). Thus, the pathway involving the ketene must be ruled out in these cases. Although N-acyliminium ions have been isolated in some occasions and then cyclized to the β-lactam, this is the first case, to the best of our knowledge, of direct synthesis of β-lactams from imines and acid chlorides in the absence of Et<sub>3</sub>N. In this case, an intramolecular hydrogen abstraction of 9 yields the related zwitterion 10.

Table 1

Synthesis of β-lactams 3 by reaction of phenylacetyl chloride with 1,2-iminoketones 1 in the absence of Et<sub>3</sub>N

1 R	2 R	3 R	Yield <sup>a</sup>
C <sub>6</sub> H <sub>5</sub>	H	p-MeOC <sub>6</sub> H <sub>4</sub>	60
C <sub>6</sub> H <sub>5</sub>	H	p-MeC <sub>6</sub> H <sub>4</sub>	60
C <sub>6</sub> H <sub>5</sub>	H	C <sub>6</sub> H <sub>5</sub>	50
C <sub>6</sub> H <sub>5</sub>	C <sub>6</sub> H <sub>5</sub>	p-MeOC <sub>6</sub> H <sub>4</sub>	88
C <sub>6</sub> H <sub>5</sub>	C <sub>6</sub> H <sub>5</sub>	p-MeC <sub>6</sub> H <sub>4</sub>	90
C <sub>6</sub> H <sub>5</sub>	C <sub>6</sub> H <sub>5</sub>	p-ClC <sub>6</sub> H <sub>4</sub>	80
C <sub>6</sub> H <sub>5</sub>	C <sub>6</sub> H <sub>5</sub>	C <sub>6</sub> H <sub>5</sub>	95

<sup>a</sup> Yield of pure, isolated product.

In conclusion, the pathway involving the formation of the ketene from the acid chloride must be ruled out in these cases and different pathways for the formation of the same zwitterion may be accounted for the two reactions under consideration. According to the observed stereochemistry of the β-lactams derived from benzil monoimines (1, R = R = C<sub>6</sub>H<sub>5</sub>, R = Ar) and phenylglyoxal monoimines (1, R = C<sub>6</sub>H<sub>5</sub>, R = H, R = Ar), the conrotatory cyclization of zwitterionic intermediate requires the stereochemistry 11 and 12, respectively. Isomerization of the β-lactams 13 and 14 does not occur in

the reaction conditions. Although the zwitterionic species 11 and 15 could be of similar stabilities, 16 appears to be more stable than 12. Formation of  $\beta$ -lactam 14 indicates that the reaction is governed by a faster cyclization rate of the less stable zwitterion.

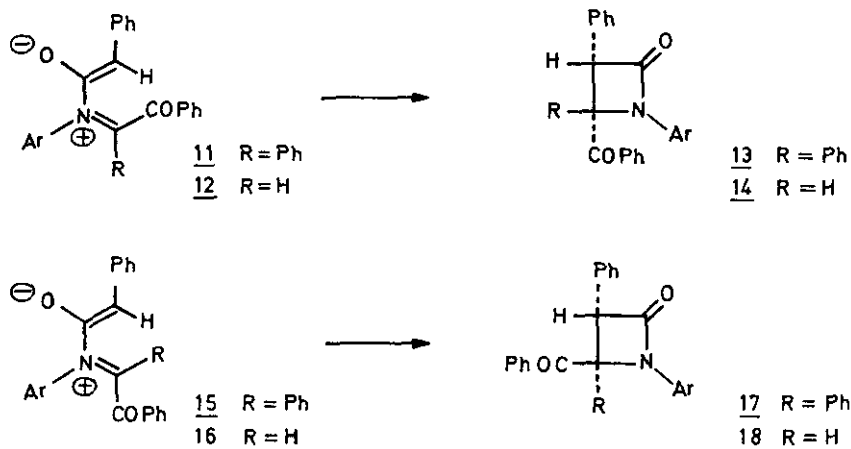

## ACKNOWLEDGEMENTS

We thank the CAYCIT for financial support (Grant 320-84).

## REFERENCES AND NOTES

- B. Alcaide, G. Domínguez, G. Escobar, U. Parreño, and J. Plumet, *Heterocycles*, 1986, 24, 1579.
  - B. Alcaide, G. Domínguez, A. Martín-Domenech, J. Plumet, A. Monge, and V. Pérez-García, *Heterocycles*, 1987, 26, 1461.
- See, for example:
  - M.S. Isaacs, *Chem.Soc.Rev.*, 1976, 5, 181.
  - A. K. Mukerjee and A. K. Singh, *Tetrahedron*, 1978, 34, 1731.
- See, for example:
  - Ch. Hubschwert and G. Schmid, *Helv.Chim.Acta*, 1983, 66, 2206.
  - J. M. Aizpurua, F. P. Cossio, B. Lecea, and C. Palomo, *Tetrahedron Lett.*, 1986, 27, 4359.
- Reactions conditions: Benzene as solvent. For the reaction starting from the phenylacetyl chloride, the imine and the acid chloride were heated at reflux together and the  $\text{Et}_3\text{N}$  was added. Diphenyl ketene was prepared according to the method of Huisgen and Teiler (R. Huisgen and L. A. Teiler, *Chem.Ber.*, 1969, 102, 3391). Yields vary between 80-90% (diastereomeric mixtures). Experimental details and configurations assignment of diastereomers will be published elsewhere.
- W. N. Speckam and R. Hiemstra, *Tetrahedron*, 1985, 41, 4367.
- T. Morimoto and M. Sekiya, *Chem.Pharm.Bull.* (Tokyo), 1976, 24, 1935.
  - D. A. Nelson, *J.Org.Chem.*, 1972, 37, 1447.

Received, 25th, January, 1988