

Contribution from the Department of Chemistry,
Wayne State University, Detroit, Michigan 48202

Complexes of Binucleating Ligands with Two Different Coordination Environments. 1. Coordinative Selectivity and Heterobinuclear Complexes: Synthesis and Characterization

R. L. LINTVEDT,* M. D. GLICK,* B. K. TOMLONOVIC, and D. P. GAVEL

Received February 19, 1976

AIC60136F

A series of molecular heterobinuclear chelates is reported which makes use of a binucleating ligand with two different coordination sites. The ligand employed, referred to as $H_4(BAA)_2en$, is the ethylenediamine Schiff base derivative of 1-phenyl-1,3,5-hexanetrione and has one site with two nitrogen and two oxygen donors ($-N_2O_2$) and a second site with four oxygen donors ($-O_2O_2$). Two central oxygen donors are common to both sites. The systematic preparation of pure mixed-metal molecules depends upon the coordination selectivity of these two sites with respect to different metal ions. The coordination selectivity has been investigated by the preparation and characterization of two mononuclear chelates; in $NiH_2(BAA)_2en$, the nickel(II) is in the N_2O_2 site, and in $VO(BAA)_2en$, the vanadium(IV) is in the O_2O_2 site. The single-crystal x-ray structure determination of the latter is reported. The nickel chelate $NiH_2(BAA)_2en$ was used as a ligand to prepare the binuclear complexes $NiM(BAA)_2en$ where $M = Zn(II)$, $Cu(II)$, $Co(II)$, $Fe(III)$, $Mn(II)$, and $VO(II)$. Characterization of these heterobinuclear molecular chelates is on the basis of analytical, mass spectral, infrared, EPR, Mössbauer, and magnetic susceptibility results. In all cases the results are consistent for pure compounds with $Ni(II)$ in the $-N_2O_2$ site and M in the $-O_2O_2$ site.

Introduction

It is well established that the number and type of donor atoms bonded to a metal ion have a profound effect on the chemical and physical properties associated with the metal ion. Moreover, it is established that, under competitive conditions, certain metal ions have a clear thermodynamic and/or kinetic preference for bonding to specific donor atoms. These facts lead one to conclude that many interesting and unusual metal complexes could be prepared from ligands that have the ability to coordinate two metal ions per molecule and ligands in which the coordinating sites contain different types of donor atoms. A versatile class of ligands that fulfills these requirements is the diamine Schiff base derivatives of 1,3,5-triketones and related systems. A generalized structure (in the enolic form) is shown as I. Presumably, the diamine and the R groups

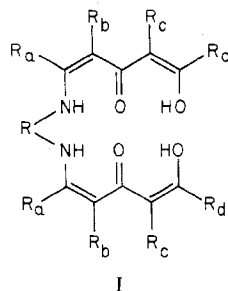

attached to the "backbone" may be a wide variety of substituents. The ligand system shown is potentially tetraanionic with two nitrogen and four oxygen donor atoms. Many other systems can be envisioned with other donor atoms and fewer enolizable protons, but these would also fall into the broad category of the ligands described above, i.e., binucleating ligands with two different coordination environments.

The compounds described herein are mononuclear, homobinuclear, and heterobinuclear complexes of the ethylenediamine Schiff base derivative of 1-phenyl-1,3,5-hexanetrione. Preliminary results have been communicated.^{1,2} An advantage of this particular ligand system is that the resulting complexes can be compared to chelates of the well-known 1,3-diketones and their Schiff base derivatives since, to a first approximation, the binuclear complexes can be thought of as fusions of the mononuclear parent complexes (eq 1). Thus one would expect similar magnetic, spectral, and chemical properties for the metal ion M_a in $M_a(acac)_2en$ and in the binuclear complex and for the metal ion M_b in $M_b(dik)_2$

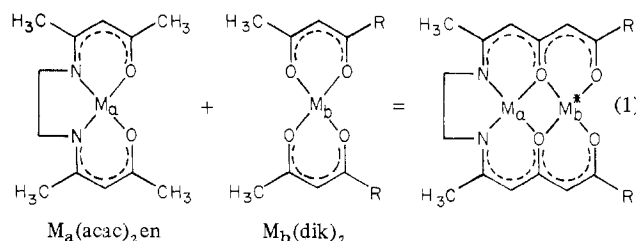

and in the binuclear complex (dik = diketonate). The wealth of information about the properties of the Schiff base 1,3-diketones³ and the diketones⁴ allows one to study the binuclear molecules in a straightforward manner. Similarities between the mononuclear parent and the binuclear species result from similar electronic states for the metal ions and differences can be attributed to the interactions between the metal ions which presumably take place through the bridging oxygens.

This study deals with the coordinative selectivity of the two sites in Schiff base 1,3,5-triketones and the systematic synthesis of pure heterobinuclear complexes.

Experimental Section

I. Syntheses. A. Ligand. 1. 1-Phenyl-1,3,5-hexanetrione, H_2BAA .

The triketone whose common name is benzoylacetone (abbreviated H_2BAA) was prepared by the method of Miles, Harris, and Hauser.⁵ This involved the condensation of 2,4-pentanedione with ethyl benzoate using NaH in refluxing tetrahydrofuran.

2. $5,5'-(1,2-Ethanediyldinitrilo)bis[1-phenyl-1,3-hexanedione]$,⁶ $H_4(BAA)_2en$. The preparation, some physical properties, and analytical data for the ethylenediamine Schiff base derivative of H_2BAA have been reported in a previous paper.⁷

B. Mononuclear Chelates. 1. $[[5,5'-(1,2-Ethanediyldinitrilo)bis[1-phenyl-1,3-hexanedionato]](2-)-N^5, N^5', O^3, O^3']nickel$,⁶ $NiH_2(BAA)_2en \cdot N_2O_2$. Two solutions were prepared; one containing 5.19 g (12.0 mmol) of $H_4(BAA)_2en$ in approximately 1 l. of boiling acetone and another containing 2.99 g (12.0 mmol) of $Ni(C_2H_3O_2)_2 \cdot 4H_2O$ in a minimum of H_2O . The $Ni(II)$ solution was added slowly to the hot ligand solution resulting in a deep wine red solution of the chelate. Heating and stirring were continued and the volume was reduced to about 150 ml. This solution was cooled to 0 °C and filtered. The red crystalline product may be recrystallized from acetone. Yields are 6.0 g or about 85%. The red crystals melt at 172–174 °C. Anal. Calcd for $NiC_{26}H_{26}N_2O_4$: C, 63.84; H, 5.38; N, 5.73. Found: C, 63.56; H, 5.32; N, 5.73.

2. $[[5,5'-(1,2-Ethanediyldinitrilo)bis[1-phenyl-1,3-hexanedionato]](2-)-O, O', O'', O''']copper$, $CuH_2(BAA)_2en \cdot O_2O_2$. The same procedure was used for this complex as for $NiH_2(BAA)_2en$. Pre-

precipitation of the product took place much more readily, however, since the oxygen-bonded copper chelate is much less soluble in acetone than the N_2O_2 -bonded nickel chelate. The small brown crystals may be recrystallized from acetone (large volumes and prolonged heating are required). Yields are typically 85%. The product melts at 228–231 °C. Anal. Calcd for $CuC_{26}H_{26}N_2O_4$: C, 63.19; H, 5.30; N, 5.65; Cu, 12.90. Found: C, 63.01; H, 5.38; N, 5.54; Cu, 12.72.

3. $[\mu-[5,5'-(1,2-Ethanediyldinitrilo)bis[1-phenyl-1,3-hexanedionato]](2-)-O,O',O'',O''']oxovanadium-acetone, VOH_2(BAA)_2en \cdot (CH_3)_2CO \cdot O_2$. Freshly prepared, finely divided $VO(OH)_2$ was mixed with an equimolar amount of $H_4(BAA)_2en$ in a flask fitted with a condenser and a stirrer. Absolute methanol was added to this mixture and with stirring it was refluxed for 9 h. A pea green precipitate formed almost immediately. Filtration yielded crude product and unreacted starting materials. The mixture was stirred in boiling chloroform and filtered hot. On cooling, unreacted ligand crystallized and upon evaporation green microcrystals formed. The green crystals were recrystallized from acetone and finally from pyridine. Relatively large blue air-stable crystals resulted from slow crystallization from pyridine. The product melts with decomposition at 276–278 °C. Anal. Calcd for $VC_{26}H_{26}N_2O_5 \cdot (CH_3)_2CO$: C, 62.70; H, 5.76; N, 5.05. Found: C, 62.85; H, 5.76; N, 5.29.

C. **Binuclear Chelates.** A general approach to the synthesis of the heterobinuclear chelates was used which involves the reaction of pure $NiH_2(BAA)_2en$ with the appropriate metal acetate. The following procedure was used. A suspension of 2.0 g (4.1 mmol) of $NiH_2(BAA)_2en$ in 500 ml of absolute methanol in a 1 l. three-neck flask fitted with a condenser and a dropping funnel was stirred and refluxed for 2–3 h. A solution of 4.1 mmol of the appropriate metal acetate dissolved in a minimum amount of absolute methanol (25–50 ml) was slowly added over a period of about 1 h to the refluxing mixture. This mixture was refluxed for approximately 20 h and then cooled slowly (about 3–4 h) to room temperature without stirring. (Note: in cases where the metal acetate is not readily available, stoichiometric amounts of sodium acetate dissolved in methanol were added to the refluxing $NiH_2(BAA)_2en$ -methanol suspension followed by a stoichiometric amount of the metal chloride dissolved in methanol.) After cooling, the mixture was filtered, and the solid was washed with methanol and air-dried on the filter. Recrystallization may be accomplished from chloroform or acetone.

1. $[\mu-[5,5'-(1,2-Ethanediyldinitrilo)bis[1-phenyl-1,3-hexanedionato]](4-)-N^5,N^5',O^3,O^3':O^1,O^1',O^3,O^3'](nickel)zinc, NiZn(BAA)_2en$. A methanol solution of 0.90 g (4.1 mmol) of $Zn(C_2H_3O_2)_2 \cdot 2H_2O$ was added to 2.0 g of $NiH_2(BAA)_2en$ in refluxing methanol according to the above procedure. The product is a yellow-brown powder which melts with decomposition at 345–346 °C. The yield is 80% based on $NiH_2(BAA)_2en$. The product is soluble (about 10^{-3} to 10^{-4} M) in acetone, chloroform, acetonitrile, DMF, and pyridine. It is sparingly soluble in carbon tetrachloride and insoluble in water. Anal. Calcd for $NiZnC_{26}H_{24}N_2O_4$: C, 56.51; H, 4.38; N, 5.07. Found: C, 56.73; H, 4.44; N, 5.03.

$NiZn(py)(BAA)_2en$. The pyridine adduct was made by dissolving a small amount of $NiZn(BAA)_2en$ in pyridine (for example, 10 mg in 20 ml) and allowing the solution to evaporate to dryness. This solid was redissolved in pyridine and partial evaporation yielded platelike crystals which decompose upon exposure to air for more than a few minutes. Recrystallization from acetone yielded a tan powder which melts at 338–340 °C. The analysis is consistent with one coordinated pyridine. Anal. Calcd for $NiZnC_{26}H_{24}N_2O_4(C_5H_5N)$: C, 58.94; H, 4.63; N, 6.65. Found: C, 58.52; H, 4.72; N, 6.61.

2. $[\mu-[5,5'-(1,2-Ethanediyldinitrilo)bis[1-phenyl-1,3-hexanedionato]](4-)-N^5,N^5',O^3,O^3':O^1,O^1',O^3,O^3'](nickel)copper, NiCu(BAA)_2en$. A solution of 0.82 g (4.1 mmol) of $Cu(C_2H_3O_2)_2 \cdot H_2O$ in methanol was added to 2.0 g of $NiH_2(BAA)_2en$ in refluxing methanol according to the above procedure. A red-brown semicrystalline solid was collected and washed with methanol. The product melts sharply at 259–260 °C. The yield is 88% based on $NiH_2(BAA)_2en$. This compound has solubility properties similar to those of $NiZn(BAA)_2en$. Anal. Calcd for $NiCuC_{26}H_{24}N_2O_4$: C, 56.70; H, 4.39; N, 5.09. Found: C, 56.87; H, 4.31; N, 5.04.

3. $[\mu-[5,5'-(1,2-Ethanediyldinitrilo)bis[1-phenyl-1,3-hexanedionato]](4-)-N^5,N^5',O^3,O^3':O^1,O^1',O^3,O^3']dinickel-Methanol, NiNi(BAA)_2en \cdot CH_3OH$. A solution of 1.02 g (4.1 mmol) of $Ni(C_2H_3O_2)_2 \cdot 4H_2O$ in methanol was added to a refluxing mixture of 2.0 g of $NiH_2(BAA)_2en$ in methanol. The resulting product is a red-brown semicrystalline compound which when recrystallized from

chloroform melts with decomposition at 342 °C. The yield based on $NiH_2(BAA)_2en$ is 25%. Its solubility properties are similar to those of $NiZn(BAA)_2en$. Anal. Calcd for $Ni_2C_{26}H_{24}N_2O_4 \cdot CH_3OH$: C, 56.11; H, 4.88; N, 4.85. Found: C, 56.31; H, 4.91; N, 4.85.

$NiNi(py)_2(BAA)_2en \cdot py$. Well-formed, air-stable crystals of this pyridine adduct may be prepared by the same procedure used to prepare $NiZn(py)(BAA)_2en$. Anal. Calcd for $Ni_2C_{26}H_{24}N_2O_4 \cdot (C_5H_5N)_3$: C, 62.92; H, 4.99; N, 8.95. Found: C, 62.75; H, 5.12; N, 9.25.

4. $[\mu-[5,5'-(1,2-Ethanediyldinitrilo)bis[1-phenyl-1,3-hexanedionato]](4-)-N^5,N^5',O^3,O^3':O^1,O^1',O^3,O^3'](nickel)cobalt-Methanol, NiCo(BAA)_2en \cdot CH_3OH$. A methanol solution of 1.02 g (4.1 mmol) of $Co(C_2H_3O_2)_2 \cdot 4H_2O$ was added to 2.0 g of $NiH_2(BAA)_2en$ in refluxing methanol. The dark red-brown microcrystals that resulted were collected and washed with methanol and hot chloroform. This product melts at 330 °C. The yield based on $NiH_2(BAA)_2en$ is 60%. The solubility properties are similar to $NiZn(BAA)_2en$. Anal. Calcd for $NiCoC_{26}H_{24}N_2O_4 \cdot CH_3OH$: C, 56.09; H, 4.88; N, 4.85. Found: C, 55.57; H, 4.84; N, 4.78.

5. $\mu-Oxobis[\mu-[5,5'-(1,2-ethanediyldinitrilo)bis[1-phenyl-1,3-hexanedionato]](4-)-N^5,N^5',O^3,O^3':O^1,O^1',O^3,O^3'](nickel)iron hydrate, NiFe(BAA)_2en(H_2O)_2 \cdot O$. A solution of 0.67 g (8.2 mmol) of $Na_2C_2H_3O_2$ in methanol was added to 2.0 g of $NiH_2(BAA)_2en$ in refluxing methanol followed by a methanol solution of 0.81 g (4.1 mmol) of $FeCl_2 \cdot 4H_2O$. No effort was made to exclude air during any of the preparation. A dark green microcrystalline solid was collected which was washed with methanol and recrystallized from acetone. The product melts with decomposition at 338–340 °C. The yield is 50% based on $NiH_2(BAA)_2en$. The compound is soluble (about 10^{-3} M) in acetone, chloroform, acetonitrile, and DMF. Anal. Calcd for $NiFeC_{26}H_{24}N_2O_4(H_2O)_0.5$: C, 54.87; H, 4.61; N, 4.92. Found: C, 55.49; H, 4.49; N, 4.91.

6. $[\mu-[5,5'-(1,2-Ethanediyldinitrilo)bis[1-phenyl-1,3-hexanedionato]](4-)-N^5,N^5',O^3,O^3':O^1,O^1',O^3,O^3'](nickel)manganese-Methanol, NiMn(BAA)_2en \cdot CH_3OH$. A methanol solution of 1.0 g (4.1 mmol) of $Mn(C_2H_3O_2)_2 \cdot 4H_2O$ was added to 2.0 g of $NiH_2(BAA)_2en$ in refluxing methanol. The dark red-black microcrystalline solid that resulted was collected and washed with methanol. The product melts at 345 °C. The yield based on $NiH_2(BAA)_2en$ is 30%. Its solubility properties are similar to those of $NiZn(BAA)_2en$. Anal. Calcd for $NiMnC_{26}H_{24}N_2O_4 \cdot CH_3OH$: C, 56.48; H, 4.92; N, 4.88. Found: C, 56.33; H, 4.98; N, 4.80.

7. $[\mu-[5,5'-(1,2-Ethanediyldinitrilo)bis[1-phenyl-1,3-hexanedionato]](4-)-N^5,N^5',O^3,O^3':O^1,O^1',O^3,O^3'](nickel)oxovanadium, NiVO(BAA)_2en$. A methanol solution containing 0.67 g (8.2 mmol) of $Na_2C_2H_3O_2$ was added to 2.0 g of $NiH_2(BAA)_2en$ in refluxing methanol followed by 0.57 g (4.1 mmol) of $VOCl_2$ in methanol. The resulting dark brown-red microcrystalline solid was collected, washed with methanol, and recrystallized from acetone. The product melts with decomposition at 347 °C. The yield based upon $NiH_2(BAA)_2en$ is 75%. The product is soluble in acetone, chloroform, acetonitrile, and DMF. Anal. Calcd for $NiVC_{26}H_{24}N_2O_5$: C, 56.35; H, 4.37; N, 5.06. Found: C, 56.15; H, 4.43; N, 5.06.

II. **Physical Measurements.** Infrared spectra were recorded on a Perkin-Elmer 267 or a 621 spectrometer using KBr pellets. The spectra were calibrated in the 1600-, 1000-, and 550- cm^{-1} regions with polystyrene. Electronic absorption spectra were recorded with 10^{-3} M $CHCl_3$ or DMF solutions using a Cary 14 spectrometer. Mass spectra were recorded with an AEI MD 902 mass spectrometer by the direct-probe technique. The source temperature was generally about 300 °C. EPR spectra were recorded on a Varian E-4 spectrometer. Room-temperature Mossbauer spectra of $[NiFe(BAA)_2en(H_2O)]_2O$ were done by Professor P. Kenealy, Physics Department, Wayne State University.

Melting points were measured with a Thomas-Hoover Unimelt with sealed capillary tubes. The reported values are uncorrected. The molecular weight of the Ni-Fe complex was determined cryoscopically in camphor. Typical freezing point depressions for the mixtures used were 4–5 °C.

Magnetic susceptibilities were measured by the Faraday method using $Hg[Co(SCN)_4]$ as a calibrant. All measurements were made at field strengths of about 9000 G. The diamagnetic susceptibility of $NiH_2(BAA)_2en$ was experimentally determined to be -243.57×10^{-6} cgsu while the value calculated from Pascal's constants⁹ is -246.48×10^{-6} cgsu. Corrections for diamagnetic effects in binuclear chelates were made using the experimental value of -150×10^{-6} cgsu obtained

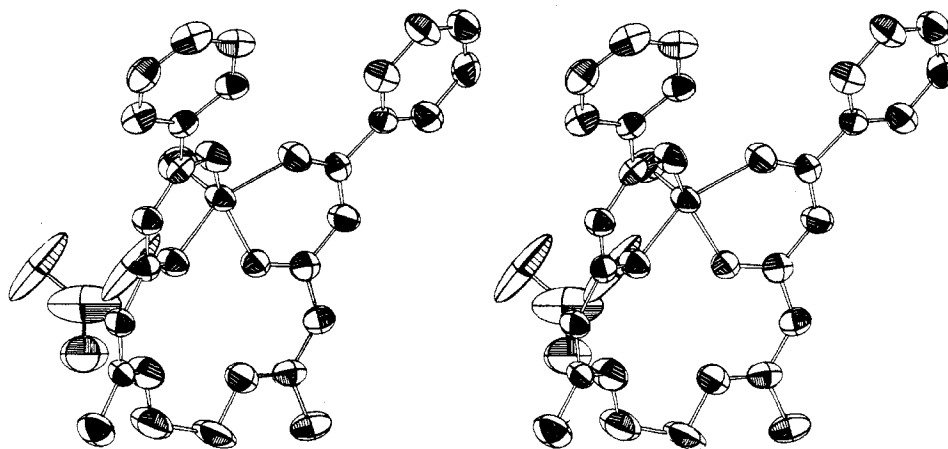

Figure 1. Stereoscopic view of $\text{VOH}_2(\text{BAA})_2\text{en}\cdot(\text{CH}_3)_2\text{CO}$.

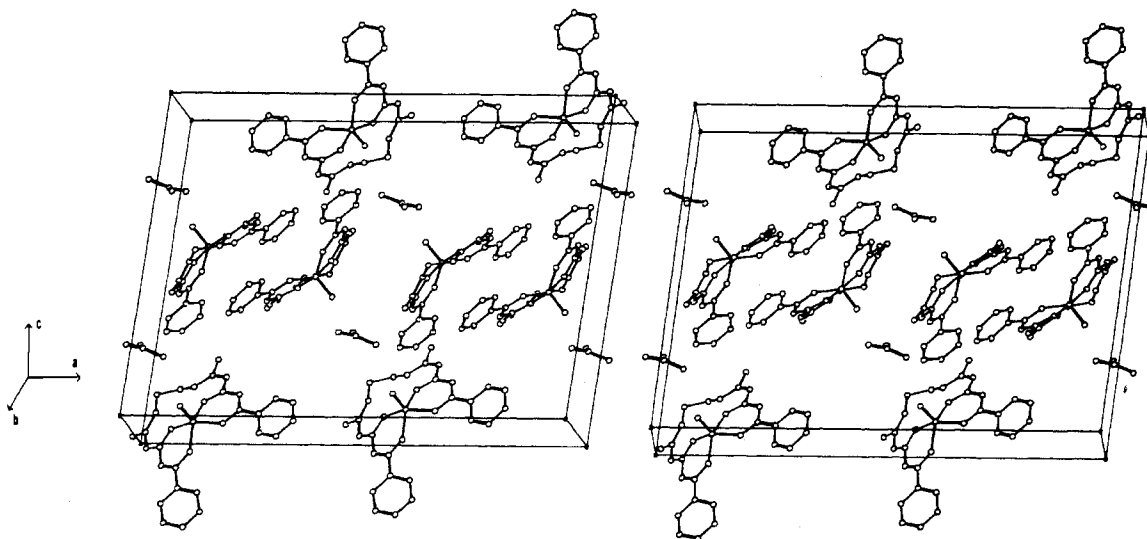

Figure 2. Stereoscopic view of the $\text{VOH}_2(\text{BAA})_2\text{en}\cdot(\text{CH}_3)_2\text{CO}$ unit cell.

from the diamagnetic chelate $\text{NiZn}(\text{BAA})_2\text{en}$.

III. Structure Determination of $\text{VOH}_2(\text{BAA})_2\text{en}\cdot(\text{CH}_3)_2\text{CO}$. A dark blue single crystal of the form of a rectangular parallelepiped with dimensions $0.23 \times 0.19 \times 0.19$ mm was mounted on a glass fiber with epoxy adhesive. Precession photographs showed $2/m$ Laue symmetry and systematic absences of $l = 2n + 1$ for $\{h0l\}$ and $h + k = 2n + 1$ for $\{hkl\}$, consistent with the monoclinic space groups Cc and $C2/c$. Least-squares refinement of 15 reflections centered on a Syntex $P2_1$ diffractometer with $\text{Mo K}\alpha$ radiation (λ 0.710 69 Å) diffracted from a graphite monochromator yielded cell parameters of $a = 27.384$ (12) Å, $b = 9.513$ (2) Å, $c = 19.816$ (9) Å, and $\beta = 82.89$ (2)°. The experimental density (flotation) of 1.38 g cm^{-3} was in poor agreement with the initially calculated density of 1.29 g cm^{-3} based upon eight molecules of $\text{VOH}_2(\text{BAA})_2\text{en}$ but was in excellent agreement with that of 1.37 g cm^{-3} calculated by including eight molecules of acetone per cell.

Intensity data were collected on the Syntex diffractometer by the θ - 2θ technique. The scan rate varied in inverse proportion to the peak intensity from 0.93 to $3.99^\circ/\text{min}$; the scan range was from $2\theta(\text{Mo K}\alpha_1) - 0.8^\circ$ to $2\theta(\text{Mo K}\alpha_2) + 0.9^\circ$; backgrounds were measured at each end of the scan for a total time equal to half the scan time. No significant fluctuations were observed in the intensities of five standard reflections examined following every 100 data. Standard deviations¹⁰ were assigned to the intensities according to the formula $\sigma(I) = (\sigma_{\text{counter}}^2 + 0.03I^2)^{1/2}$, where $\sigma_{\text{counter}} = (I + 4B)^{1/2}$, I is the net intensity, and B is the total background counts. Absorption corrections ($\mu_a = 4.40 \text{ cm}^{-1}$) were not deemed necessary. Of the 3659 independent data examined, 2211 had $I > 3\sigma(I)$ and were used in the solution and refinement process.

The centrosymmetric space group $C2/c$ was used throughout the analysis and confirmed by the final refinement process. A Patterson

synthesis yielded the position of the independent vanadium atom. Successive Fourier syntheses in which the pseudosymmetry was gradually destroyed yielded the positions of all 34 nonhydrogen atoms in the $\text{VOH}_2(\text{BAA})_2\text{en}$ molecule resulting in $R = \sum \|F_o\| - |F_c| / \sum \|F_o\| = 0.189$. At this stage it was possible to identify an acetone of crystallization from the difference Fourier synthesis. Block-diagonal least-squares refinement of all nonhydrogen atom coordinates with isotropic thermal parameters yielded $R = 0.088$ and $R_w = [\sum (|F_o| - |F_c|)^2 / \sum F_o^2]^{1/2} = 0.103$. Hydrogen atom positions were then calculated with C-H distances of 0.97 Å and verified from a difference Fourier synthesis. Block-diagonal least-squares refinement¹¹ with anisotropic thermal parameters for nonhydrogen atoms and fixed contributions from the hydrogen atoms converged with $R = 0.054$, $R_w = 0.056$, an error of fit of 2.00, and a maximum residual electron density of $0.26 \text{ e}/\text{Å}^3$. Atomic parameters are given in Table I. A listing of calculated and observed structure factors is available as supplementary material.

Description of Structure of $\text{VOH}_2(\text{BAA})_2\text{en}\cdot(\text{CH}_3)_2\text{CO}$

The structure is shown to comprise discrete monomeric molecules of $\text{VOH}_2(\text{BAA})_2\text{en}$ with uncoordinated acetone molecules of solvation. Figures 1 and 2 show stereoscopic views of the $\text{VOH}_2(\text{BAA})_2\text{en}$ molecule and the entire unit cell contents, respectively. Figures 3 and 4 show distances and angles within the ligand framework and the metal coordination sphere, respectively.

The vanadium atom is located at the O_2O_2 coordination site of the $\text{H}_2(\text{BAA})_2\text{en}$ ligand. The vanadium atom is displaced 0.56 Å from the average plane (Table II) of the four equatorial oxygen atoms in typical five-coordinate fashion.

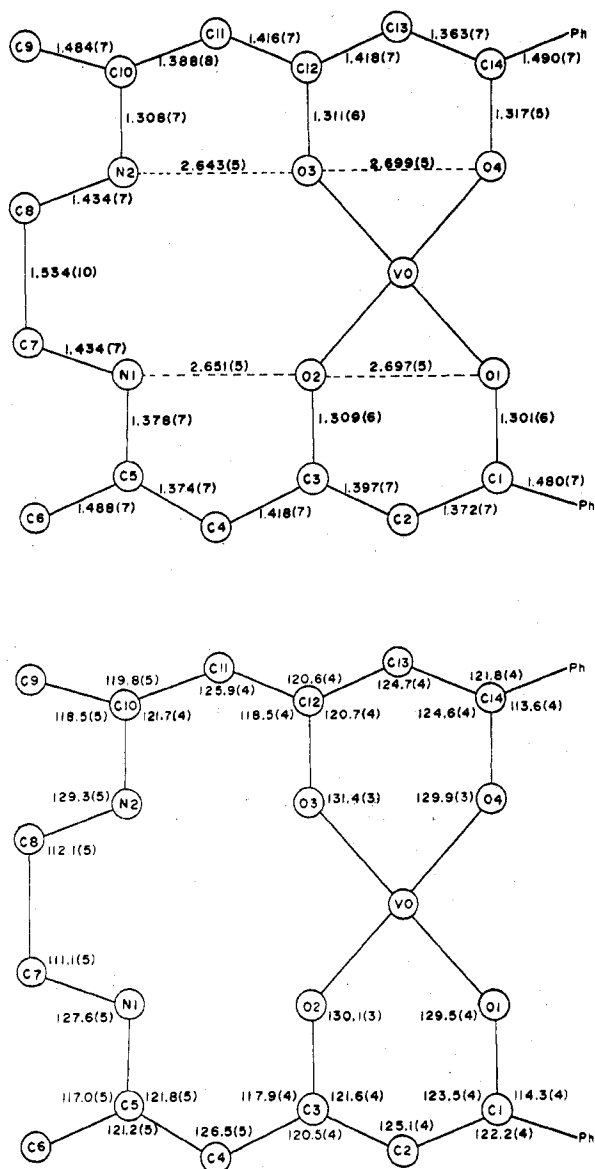

Figure 3. Distances and angles within the ligand framework in $\text{VOH}_2(\text{BAA})_2\text{en} \cdot (\text{CH}_3)_2\text{CO}$.

The axial $\text{V}=\text{O}$ distance of 1.625 Å is centered in the range (1.52–1.68 Å) reported for vanadyl groups.¹² In most reports of five-coordinate vanadyl complexes, there is a donor atom located opposite the axial oxygen but considerably further away; that site is occupied by a phenyl group here thus precluding any such weak interaction. The equatorial $\text{V}-\text{O}$ distances are from two populations. The $\text{V}-\text{O}$ distances to the terminal oxygens average 1.930 Å whereas the $\text{V}-\text{O}$ distances to the potentially bridging oxygens average 1.963 Å. This lengthening of the bonds to the central oxygens relative to the terminal oxygens has been previously observed in structures of binuclear complexes of the β -triketonates but was not observed⁷ in the mononuclear copper(II) complex of $\text{H}_2(\text{BAA})_2\text{en}$. A broad range of equatorial $\text{V}-\text{O}$ distances (1.75–2.16 Å) has been reported in other compounds.¹²

The average "bite" distance between adjacent ketonic oxygens is 2.70 Å, about 0.10 Å shorter than the average value found in β -triketone structures.⁷ The adjacent $\text{O}=\text{O}$ and $\text{N}=\text{O}$ bite distances of 2.70 and 2.65 Å (average) may be compared with the corresponding values of 2.75 and 2.60 Å in $\text{CuH}_2(\text{BAA})_2\text{en}$.⁷ It is seen that the central oxygen atom has been pulled 0.05 Å toward the terminal oxygen in going from the copper complex to the vanadium complex. This may be at-

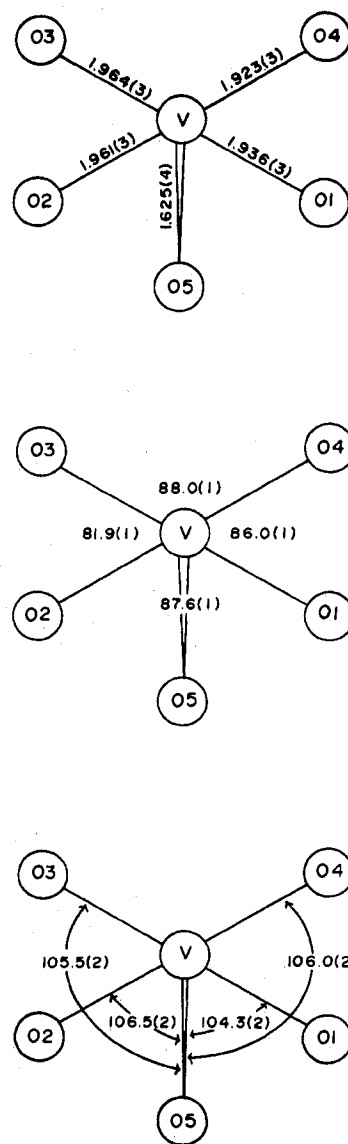

Figure 4. Coordination sphere parameters for vanadium in $\text{VOH}_2(\text{BAA})_2\text{en} \cdot (\text{CH}_3)_2\text{CO}$.

tributed to the much smaller displacement (0.06 Å) of the copper from the equatorial plane.

Distances and angles in the ligand framework are comparable to those found⁷ in $\text{CuH}_2(\text{BAA})_2\text{en}$. The $\text{N}-\text{C}-\text{C}-\text{N}$ fragment is of aliphatic character and joins the two fragments with π -electron delocalization.

Results and Discussion

There are several research areas in which it would be advantageous to have a variety of well-characterized mixed-metal molecular complexes available. These areas include the study of magnetic superexchange, mixed oxidation state studies, development of unusual homogeneous catalysts, and the design of materials with unusual solid-state properties. Clearly, the first problem encountered is associated with the preparation and characterization of pure products. The next is to develop dependable, systematic synthetic procedures so that many pure heteronuclear complexes may be prepared rather than just a few isolated examples.

Several synthetic approaches could be taken to prepare heteronuclear complexes, the simplest of which is the simultaneous addition of 1:1:1 molar quantities of metal ion A, metal ion B, and the ligand. This procedure and ones related to it could, however, result in products ranging from the pure

Table I. Atomic Coordinates and Anisotropic Thermal Parameters^a for VOH₂(BAA)₂en·(CH₃)₂CO

	x	y	z		x	y	z
V	-0.124 08 (3)	0.267 24 (8)	0.453 92 (4)	C12	-0.0680 (2)	0.4328 (5)	0.5474 (2)
O1	-0.185 7 (1)	0.169 8 (4)	0.449 5 (2)	C13	-0.0713 (2)	0.3211 (5)	0.5951 (2)
O2	-0.151 1 (1)	0.423 5 (3)	0.405 7 (2)	C14	-0.0976 (2)	0.2008 (5)	0.5899 (2)
O3	-0.086 8 (1)	0.420 3 (3)	0.490 0 (2)	C15	-0.1026 (2)	0.0927 (5)	0.6447 (2)
O4	-0.122 0 (1)	0.170 2 (3)	0.538 6 (2)	C16	-0.1430 (2)	0.0017 (5)	0.6500 (2)
O5	-0.085 1 (1)	0.186 8 (4)	0.398 5 (2)	C17	-0.1494 (2)	-0.0991 (5)	0.7011 (3)
N1	-0.139 5 (2)	0.696 8 (4)	0.383 0 (2)	C18	-0.1160 (2)	-0.1109 (6)	0.7470 (3)
N2	-0.061 6 (2)	0.684 6 (4)	0.463 5 (2)	C19	-0.0757 (2)	-0.0234 (6)	0.7420 (3)
C1	-0.219 8 (2)	0.193 8 (5)	0.410 7 (2)	C20	-0.0694 (2)	0.0789 (6)	0.6919 (3)
C2	-0.222 1 (2)	0.314 3 (5)	0.373 2 (3)	C21	-0.2574 (2)	0.0818 (5)	0.4120 (2)
C3	-0.190 2 (2)	0.428 8 (5)	0.373 9 (2)	C22	-0.2592 (2)	-0.0227 (6)	0.4613 (3)
C4	-0.199 9 (2)	0.556 0 (5)	0.340 7 (3)	C23	-0.2924 (2)	-0.1324 (6)	0.4625 (3)
C5	-0.176 2 (2)	0.682 2 (6)	0.345 6 (2)	C24	-0.3240 (2)	-0.1396 (6)	0.4139 (3)
C6	-0.190 5 (2)	0.808 9 (6)	0.308 6 (3)	C25	-0.3234 (2)	-0.0386 (6)	0.3657 (3)
C7	-0.116 9 (3)	0.825 0 (6)	0.401 2 (3)	C26	-0.2909 (2)	0.0728 (6)	0.3648 (3)
C8	-0.064 2 (3)	0.799 0 (6)	0.417 0 (4)	O6	0.0	0.6392 (7)	0.2500
C9	-0.025 8 (2)	0.816 3 (6)	0.548 3 (3)	C27	0.0	0.5222 (11)	0.2500
C10	-0.045 6 (2)	0.683 8 (5)	0.523 0 (3)	C28	0.0441 (4)	0.4301 (10)	0.2315 (5)
C11	-0.046 4 (2)	0.562 7 (5)	0.562 2 (3)				
	β_{11}	β_{22}	β_{33}	β_{12}	β_{13}	β_{23}	
V	0.001 45 (1)	0.0085 (1)	0.002 22 (2)	-0.000 79 (4)	-0.000 73 (2)	0.000 52 (5)	
O1	0.001 6 (1)	0.0110 (5)	0.003 3 (1)	-0.001 0 (3)	-0.001 0 (1)	0.001 6 (4)	
O2	0.001 4 (1)	0.0089 (5)	0.003 0 (1)	-0.000 6 (3)	-0.000 6 (1)	0.000 9 (4)	
O3	0.001 7 (1)	0.0098 (5)	0.002 4 (1)	-0.000 8 (3)	-0.000 6 (1)	0.000 1 (4)	
O4	0.001 9 (1)	0.0116 (5)	0.002 6 (1)	-0.001 3 (3)	-0.001 1 (1)	0.000 6 (4)	
O5	0.002 1 (1)	0.0145 (6)	0.003 2 (1)	0.000 7 (4)	-0.000 5 (2)	-0.001 8 (5)	
N1	0.002 1 (1)	0.0091 (6)	0.004 3 (2)	-0.000 4 (4)	-0.001 0 (2)	0.001 7 (6)	
N2	0.002 4 (1)	0.0094 (6)	0.004 4 (2)	-0.001 6 (4)	-0.001 5 (2)	0.000 8 (6)	
C1	0.001 2 (1)	0.0102 (7)	0.002 4 (2)	0.000 1 (4)	-0.000 5 (2)	-0.000 6 (6)	
C2	0.001 6 (1)	0.0105 (7)	0.002 5 (2)	-0.000 3 (4)	-0.000 8 (2)	0.000 5 (6)	
C3	0.001 3 (1)	0.0097 (7)	0.002 3 (2)	0.000 3 (4)	-0.000 1 (2)	0.000 2 (6)	
C4	0.001 4 (1)	0.0097 (7)	0.003 0 (2)	0.000 2 (4)	-0.000 4 (2)	0.000 8 (6)	
C5	0.001 6 (1)	0.0110 (8)	0.002 3 (2)	0.000 1 (5)	0.0 (2)	0.000 5 (6)	
C6	0.002 2 (1)	0.0111 (8)	0.003 5 (2)	0.000 9 (5)	-0.000 1 (3)	0.002 3 (7)	
C7	0.003 3 (2)	0.0083 (8)	0.005 6 (3)	-0.002 6 (6)	-0.000 9 (3)	0.001 3 (8)	
C8	0.002 9 (2)	0.0123 (10)	0.006 3 (3)	-0.001 1 (6)	-0.001 1 (3)	0.003 3 (9)	
C9	0.001 7 (1)	0.0132 (9)	0.004 7 (2)	-0.001 1 (5)	-0.000 1 (3)	-0.002 0 (8)	
C10	0.001 0 (1)	0.0096 (7)	0.003 6 (2)	-0.000 4 (4)	-0.000 2 (2)	-0.001 3 (6)	
C11	0.001 3 (1)	0.0095 (8)	0.003 4 (2)	-0.000 3 (4)	-0.000 7 (2)	-0.001 3 (6)	
C12	0.001 0 (1)	0.0107 (7)	0.002 3 (2)	0.000 2 (4)	-0.000 2 (2)	-0.001 0 (6)	
C13	0.001 4 (1)	0.0105 (7)	0.002 4 (2)	-0.000 2 (4)	-0.000 6 (2)	-0.000 2 (6)	
C14	0.001 0 (1)	0.0100 (7)	0.002 2 (2)	0.000 6 (4)	-0.000 3 (2)	-0.000 4 (6)	
C15	0.001 2 (1)	0.0095 (7)	0.001 8 (2)	0.000 5 (4)	-0.000 2 (2)	-0.000 6 (5)	
C16	0.001 7 (1)	0.0104 (8)	0.002 3 (2)	0.000 3 (5)	-0.000 7 (2)	-0.000 8 (6)	
C17	0.002 2 (1)	0.0093 (8)	0.002 7 (2)	-0.000 3 (5)	-0.000 1 (2)	0.0 (6)	
C18	0.002 7 (1)	0.0120 (8)	0.001 9 (2)	0.001 0 (6)	-0.000 4 (2)	0.000 3 (6)	
C19	0.001 7 (1)	0.0159 (9)	0.002 7 (2)	0.001 0 (5)	-0.000 8 (2)	0.0 (7)	
C20	0.001 5 (1)	0.0131 (8)	0.002 5 (2)	0.000 3 (5)	-0.000 3 (2)	0.0 (6)	
C21	0.001 2 (1)	0.0093 (7)	0.002 6 (2)	-0.000 3 (4)	-0.000 4 (2)	-0.000 9 (6)	
C22	0.001 7 (1)	0.0127 (8)	0.002 5 (2)	-0.001 0 (5)	-0.000 2 (2)	-0.000 3 (6)	
C23	0.001 9 (1)	0.0131 (8)	0.003 1 (2)	-0.001 3 (5)	0.000 1 (2)	0.0 (7)	
C24	0.001 5 (1)	0.0126 (9)	0.004 7 (2)	-0.001 1 (5)	0.000 1 (3)	-0.001 8 (7)	
C25	0.001 5 (1)	0.0158 (9)	0.004 4 (2)	-0.000 5 (5)	-0.001 0 (3)	-0.001 7 (8)	
C26	0.001 6 (1)	0.0101 (8)	0.004 0 (2)	-0.000 3 (5)	-0.000 9 (2)	-0.000 2 (7)	
O6	0.003 7 (2)	0.0145 (10)	0.008 1 (4)	0.0	-0.001 7 (4)	0.0	
C27	0.007 7 (4)	0.0180 (16)	0.003 5 (4)	0.0	-0.003 4 (7)	0.0	
C28	0.008 0 (3)	0.0385 (20)	0.005 9 (4)	0.011 1 (14)	-0.002 4 (6)	-0.006 4 (15)	

^a The anisotropic thermal parameters are of the form $\exp[-(h^2\beta_{11} + k^2\beta_{22} + l^2\beta_{33} + 2hk\beta_{12} + 2hl\beta_{13} + 2kl\beta_{23})]$.

heterobinuclear chelates to an equimolar mixture of the homonuclear chelates M_AM_AL and M_BM_BL. In addition, two positional isomers, M_AM_BL and M_BM_AL, may well result. One could envision a statistical distribution of the four binuclear chelates, as well as mononuclear products. It is, therefore, necessary to devise reliable methods of isolating and characterizing pure products. Due to the similarities of the products and the expected intimate nature of the mixtures both tasks would most likely be quite difficult.

The synthetic procedures used in this work were designed (1) to minimize the possibility of producing homobinuclear chelates which would be present as impurities and (2) to avoid the potential problem of the metal ions changing positions within the molecule, i.e., the formation of positional isomers.

In order to accomplish the preparation of *pure* heterobinuclear complexes we have proceeded in a stepwise fashion as outlined below.

A. A binucleating ligand is used which has two different coordination sites resulting in a certain coordination selectivity with respect to the metal ions.

B. Various mononuclear chelates were prepared, purified, and characterized in order to investigate the selectivity of the ligand.

C. An easily characterized mononuclear chelate which can be prepared as a pure positional isomer is used as a ligand to coordinate the second metal ion.

D. The binuclear product is characterized by several physical measurements to ensure the purity of the product.

Table II. Analysis of Mean Planes in $\text{VOH}_2(\text{BAA})_2\text{en} \cdot (\text{CH}_3)_2\text{CO}$

Atom	Dev from planarity, Å	Atom	Dev from planarity, Å
Plane 1: Basal Oxygens and Nitrogens			
V	-0.564	O4	0.180
O1	-0.017	N1	0.209
O2	-0.237	N2	-0.007
O3	-0.161		
Plane 2: Basal Oxygens, Nitrogens, and Chelate Framework			
V	-0.859	C5	0.259
O1	-0.227	C7	0.444
O2	-0.401	C8	-0.355
O3	-0.497	C10	0.169
O4	-0.241	C11	0.169
N1	0.138	C12	-0.083
N2	-0.267	C13	0.130
C1	-0.024	C14	0.070
C2	0.012	C15	0.411
C3	-0.099	C16	0.218
C4	0.138		

The coordination selectivity of the two ligand sites is clearly demonstrated by the mononuclear chelates $\text{NiH}_2(\text{BAA})_2\text{en}$, $\text{CuH}_2(\text{BAA})_2\text{en}$,⁷ and $\text{VOH}_2(\text{BAA})_2\text{en}$. For $\text{NiH}_2(\text{BAA})_2\text{en}$, the spectral and magnetic properties are consistent with the nickel ion coordinated to two nitrogens and two oxygens in a square-planar arrangement. The infrared spectrum of this compound contains strong absorptions at 1675 and 1628 cm^{-1} , characteristic of unchelated keto and enol carbonyl groups. The electronic spectrum in chloroform contains an absorption at 565 m μ ($\epsilon \approx 150$), which is essentially identical with that found in $\text{Ni}(\text{acac})_2\text{en}$.¹³ The mass spectrum exhibits a strong parent ion peak (m/e 486, 488) as well as fragments due to the loss of benzoyl and related fragments.

Although the spectral results strongly suggest exclusive coordination at the ethylenediamine end of the molecule, they do not furnish useful information about purity with respect to the $-\text{O}_2\text{O}_2$ isomer. The magnetic susceptibility of $\text{NiH}_2(\text{BAA})_2\text{en}$ does, however, give a sensitive measure of the isomeric purity since $-\text{N}_2\text{O}_2$ coordination is expected to produce square-planar, diamagnetic Ni(II) as in $\text{Ni}(\text{acac})_2\text{en}$. The other isomer, with $-\text{O}_2\text{O}_2$ coordination, would be expected to produce paramagnetic, octahedral Ni(II) through adducting of solvent or water molecules or by means of oligomerization. This is a common feature of the bis(1,3-diketonato)nickel(II) chelates such as $[\text{Ni}(\text{acac})_2]_3$.¹⁴ Experimentally, $\text{NiH}_2(\text{BAA})_2\text{en}$ is diamagnetic at 300 and 77 K. The values measured agree extremely well with the calculated values based on Pascal's constants. If even a minute quantity of paramagnetic Ni(II) were present (as impurity or the $-\text{O}_2\text{O}_2$ isomer) it would be readily apparent at 77 K. Since it is not, one concludes that the product is isolated as the $-\text{N}_2\text{O}_2$ isomer in extremely pure form.

The mononuclear Cu(II) chelate, although prepared in a manner similar to $\text{NiH}_2(\text{BAA})_2\text{en}$, is isolated as the $-\text{O}_2\text{O}_2$ isomer. The structure of $\text{CuH}_2(\text{BAA})_2\text{en}$ has been reported⁷ and, indeed, the copper ion is coordinated to the four oxygens leaving the $-\text{N}_2\text{O}_2$ site vacant. In addition, there is no evidence for unchelated C-O stretches in the ir spectrum, the compound is green, and it is only very slightly soluble in solvents such as acetone, all of which are consistent with coordination to the four oxygens. The magnetic moment is normal (1.83 μ_B) throughout the temperature range 400–77 K.

The spectroscopic and magnetic properties of the mononuclear VO^{2+} complex are such that it is not possible to tell with certainty where the vanadium is coordinated and whether the product is one pure isomer. For this reason, a structure determination was undertaken on the blue crystals that resulted from acetone recrystallization. The solution of the structure of $\text{VOH}_2(\text{BAA})_2\text{en}$, vide supra, showed that the vanadium

preferentially occupies the coordination site with four basal oxygens as did the copper in $\text{CuH}_2(\text{BAA})_2\text{en}$.⁷ However, unlike the copper complex $\text{VOH}_2(\text{BAA})_2\text{en}$ is not a dimer. Distances and angles within the ligand are similar to those found in the analogous copper complex. A comparison between the coordination sphere geometries in $\text{VOH}_2(\text{BAA})_2\text{en}$ and $\text{VO}(1,3\text{-dik})_2$ ^{15,16} indicates that the angles and geometries are similar enough to justify treating the $-\text{O}_2\text{O}_2$ isomer of $\text{VOH}_2(\text{BAA})_2\text{en}$ as a simple 1,3-diketonate.

It is interesting to note that in the three mononuclear complexes which have been studied in detail, the coordination selectivity of the ligand has resulted in isomerically pure products within the limits of our measurements. While the results may not be so straightforward for many other metal ions, it is clear that coordination selectivity in binucleating ligands with two different coordination sites is a useful approach to the preparation of heterobinuclear complexes.

The choice of $\text{NiH}_2(\text{BAA})_2\text{en}$ as the mononuclear ligand used to prepare heterobinuclear chelates was made for the following reasons. (1) The compound is easily prepared in good yields and high purity. (2) Under the preparative conditions used, the $-\text{N}_2\text{O}_2$ isomer is formed exclusively. (3) The fact that with d^8 Ni(II) the $-\text{N}_2\text{O}_2$ isomer is diamagnetic while the $-\text{O}_2\text{O}_2$ isomer would be expected to be paramagnetic (through solvent coordination or oligomerization) is a powerful tool for determining the position of the metal ions in the binuclear product. (4) Ni(II) in the $-\text{N}_2\text{O}_2$ site is expected to be relatively difficult to displace, particularly by ions that exhibit a preference for the $-\text{O}_2\text{O}_2$ site. (5) And, finally, it is logical that an $-\text{N}_2\text{O}_2$ isomer with its open claws would be a better chelating ligand than the closed $-\text{O}_2\text{O}_2$ isomer.

Although $\text{NiH}_2(\text{BAA})_2\text{en} \cdot \text{N}_2\text{O}_2$ is a very interesting and convenient starting material, a paramagnetic mononuclear starting material would allow the preparation of heterobinuclear complexes of more fundamental interest to magnetic exchange and redox studies, for example. We are currently investigating several other possibilities.

The characterization of heterobinuclear complexes presents some unique problems since it is possible that no single physical characterization, including single-crystal x-ray structure determination, is totally unambiguous in determining the position of metals with similar atomic numbers and the isomeric purity of the complex. For this reason, we have employed several methods of characterization including structure determination. The results of these studies which are discussed below offer a consistent view of the binuclear complexes as isomerically pure substances with the nickel atom bonded to two nitrogens and two oxygens and the second metal to four oxygens.

The mass spectra of the heterobinuclear chelates were recorded mainly to ensure that homobinuclear complexes were not produced in the preparative steps. All of the binuclear chelates of $\text{H}_4(\text{BAA})_2\text{en}$ are sufficiently volatile and stable that spectra exhibiting intense parent ion peaks are obtained. This is extremely useful in the preliminary characterization and in judging purity with respect to the number and type of metal ions present. None of the spectra of heterobinuclear complexes contained peaks due to the presence of homobinuclear species which is interpreted as indicating that the complexes are quite pure.

The spectra are in most cases exceedingly simple in the high-mass region above m/e 105. The only peaks of appreciable intensity in most compounds above m/e 105 are due to the parent ion and the doubly charged parent ion. In addition, there are related peaks resulting from the loss of hydrogen atoms from P^+ and P^{2+} . In view of the observed fragmentation patterns for 1,3-diketonate chelates,¹⁷ the simplicity of the $\text{NiM}(\text{BAA})_2\text{en}$ mass spectra is surprising.

Table III. Mass Spectral Data for NiM(BAA)₂en (M = Co, Mn, VO)

Compd	Ion	<i>m/e</i>	Rel intens
NiCo(BAA) ₂ en	P ⁺	545, 547, 549	49
	P ⁺ - 1	544, 546, 548	49
	P ⁺ - 2	543, 545, 547	100
	P ²⁺	272.5, 273.5, 274.5	11
	P ²⁺ - 1	272, 273, 274	14
	P ²⁺ - 2	271.5, 272.5, 273.5	19
		409 382	3 2
NiMn(BAA) ₂ en	P ⁺	541, 543, 545	55
	P ⁺ - 1	540, 542, 544	45
	P ⁺ - 2	539, 541, 543	100
	P ²⁺	270.5, 271.5, 272.5	12
	P ²⁺ - 1	270, 271, 272	14
	P ²⁺ - 2	269.5, 270.5, 271.5	19
		368	4
NiVO(BAA) ₂ en	P ⁺	553, 555, 557	100
	P ⁺ - 1	552, 554, 556	62
	P ⁺ - 2	551, 553, 555	84
	P ²⁺	276.5, 277.5, 278.5	1.7
	P ²⁺ - 1	275.5, 276.5, 277.5	1.4
		353	3
		256	3

Spectra obtained at both 70- and 20-eV impact potentials are similar, indicating that the chelates are exceptionally stable with respect to fragmentation. The doubly charged parent ion peaks probably result from the presence of two metal ions per molecule which are able to stabilize the 2+ charge. The fact that the mononuclear NiH₂(BAA)₂en does not exhibit a P²⁺ peak furnishes indirect evidence for the maximum positive charge being determined by the number of metal ions present.

The cluster of mass peaks for some of the binuclear molecules is complex due to the presence of several important isotopes and the presence of peaks one and two mass units

below P⁺ and P²⁺ (loss of hydrogens). For three of the molecules, however, one of the metals has only a single important isotope. This simplifying factor, present in NiCo(BAA)₂en, NiMn(BAA)₂en, and NiVO(BAA)₂en, makes a more detailed treatment feasible. The mass spectra of these complexes in the high-mass region (above simple organic fragments) are presented in Table III. All mass peaks of relative intensity greater than 2% are included. Some of the other binuclear complexes contain additional fragmentation such as (P⁺ - metal); however, on the whole there is surprisingly little fragmentation considering the complexity of the molecules. In no cases were any peaks observed with *m/e* greater than P⁺ although other evidence indicates that association may take place in the solids.

The mass spectra of all of the binuclear chelates contain very intense peaks corresponding to the loss of two mass units (see Table III). The most reasonable explanation for these peaks is the loss of two hydrogen atoms from the saturated carbons of the ethylenediamine group. The reaction (see eq 2) appears to be a thermal process since there is no intensity

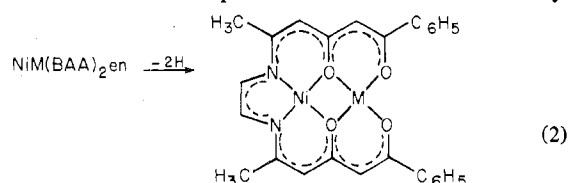

decrease in going from impact potentials of 70 to 20 eV. It is possible that the reaction is facile because the product has a conjugated π system that extends throughout the entire ligand system. Attempts at dehydrogenation by chemical means are in progress.

The infrared absorptions of NiH₂(BAA)₂en and the binuclear chelates are tabulated in Table IV. The general features of the infrared spectra of the binuclear chelates are very similar and enough different from those of NiH₂-

Table IV. Infrared Spectra of NiH₂(BAA)₂en and the Binuclear Chelates as KBr Pellets^a

NiH ₂ - (BAA) ₂ en	NiZn- (BAA) ₂ en	NiCu- (BAA) ₂ en	NiCo- (BAA) ₂ en	NiMn- (BAA) ₂ en	Ni ₂ - (BAA) ₂ en	NiVO- (BAA) ₂ en	[NiFe- (BAA) ₂ en]
1675 s							
1628 s							
1600 m	1590 m	1590 m	1587 m	1588 m	1585 m	1600 m	1590 m
1582 s	1570 m	1575 m	1570 m	1570 m	1570 m	1550 w	1578 m
1515 vs	1515 s	1515 s	1515 s	1517 s	1515 s	1515 s	1512 s, sh
1505 vs	1505 s	1505 s	1505 s	1505 s	1505 s	1505 s	1505 s
1495 vs	1487 s	1490 s	1487 s	1485, 1472 s	1485 s	1490 s	1488 s
1465, 1450, 1435 s	1455, 1438 m	1450, 1435, 1420 m	1450, 1438 m	1450, 1435 m	1450 m	1452, 1435 m	1450, 1435 m
	1400 m	1400 m	1407 m	1410 m	1408 m	1390 m	1410 m
1360, 1335, 1320 s	1358 m	1358 m	1358 m	1358 m	1357 m	1358 m	1358 m
1288, 1272, 1260 m	1280 w		1310, 1285, 1265 w	1265 w		1300, 1285 w	1265 m
1195 m	1202 m	1208 m	1205 m	1205 m	1205 m	1210 m	1205 m
1128 w	1130 w	1130 w	1130 w	1130 w	1130 w	1128 w	1130 w
1105 vw	1105 w			1117, 1100 w	1115, 1100 w	1105 w	1117, 1100 w
1075 w, d	1070 w	1070 w	1072 w	1075 w	1072 w	1070 w	1075 w
1045	1050 w	1050 w	1050 w	1050 w	1050 w	1052 w	1050 w
1015 w	1028 w	1028 w	1025 w	1030 w	1028 w	1030 w	1030 w
						990 s	
980 m	980 w	995, 980 w	990, 980 w	982 w	988 w		990 w
	912 w	917 w	912 w	912 w	912 w	912 w	910 w
872 w	890 w	892 w	888 w	885 w	888 w	888 w	888 w
							840 m, b
832 ms	805 m	792 w	800 m	800 m, d	800 m	815 m	804 m
775, 750 ms	785 m	775 m	780 m	780 m	780 m	784 m	780 m
690 ms	695 m	690 m	700 m	700 m	700 m	695, 675 m	692 m
640 m	642 w		645 w	640 w	650 w	650 w	640 w
610 w			597 w	586 w	595 w	615 w	600 w
	506 w	526 w	510 w	502 w	515 w	536 w	
		483 vw	466 w, d	466, 453 mw	477 mw	489 w	
		441 vw		420 w	426 w, d	442 vw	
						331 w, b	

^a Observed frequencies are in cm⁻¹. Key: s, strong; m, medium; w, weak; v, very; sh, shoulder; b, broad; d, doublet.

Table V. Magnetic Properties of the Binuclear NiM(BAA)₂en Chelates^a

Compd ^b	T, K	10 ⁶ χ _g ^c cgsu	10 ⁶ χ _m ^c cgsu	χ _m ^c - Nα	μ _{eff} ^d μ _B
NiVO(BAA) ₂ en	297	2.084	1 327	1 227	1.71
	77	8.982	4 975	4 875	1.73
NiCu(BAA) ₂ en	297	2.600	1 602	1 502	1.89
	77	9.950	5 651	5 551	1.85
NiMn(BAA) ₂ en	297	24.416	14 191	14 191	5.81
	77	86.009	49 556	49 556	5.53
NiCo(BAA) ₂ en	297	17.318	10 184	10 184	4.92
	77	53.319	30 999	30 999	4.37
Ni ₂ (BAA) ₂ en	297	7.904	4 473	4 223	3.17
	77	26.614	14 708	14 458	2.99
Ni ₂ (BAA) ₂ en(py) ₂	297	5.296	4 442	4 192	3.16
	77	18.576	14 834	14 584	3.00
[NiFe(BAA) ₂ en] ₂ O	297	2.7482	1 739	1 739	2.03
	77	2.528	1 614	1 614	0.99

^a Magnetic properties are on a per molecule basis. ^b Solvate molecules are omitted from the abbreviation for clarity but are included in the magnetic calculations. ^c Diamagnetic corrections for NiM(BAA)₂en are made on the basis of the experimental value of -150×10^{-6} cgsu for NiZn(BAA)₂en. ^d Calculated from the equation $\mu_{\text{eff}} = 2.83[(\chi_m - N\alpha)T]^{1/2}$.

(BAA)₂en that one can readily identify appreciable concentrations of the starting material. Although the molecules are too complex to consider assigning frequencies, it seems clear that the three strong bands at 1515, 1050, and 1490 cm⁻¹ are due to the keto imine and carbonyl groups bonded to the nickel. It is likely that the 1570-cm⁻¹ absorption is due to the chelated terminal carbonyl. In NiVO(BAA)₂en a strong band occurs at 990 cm⁻¹ which is assigned to the V=O stretch and is considered to be diagnostic for the vanadyl group.¹⁸

Another infrared absorption worthy of mentioning occurs at 840 cm⁻¹ in NiFe(BAA)₂en and is absent in the other complexes. Absorptions at 840 cm⁻¹ in iron complexes are often indicative of an Fe-O-Fe bridged system.¹⁹ In order to investigate this possibility further, the molecular weight was determined and the Mössbauer spectrum was recorded. The experimental molecular weight measured cryoscopically in camphor was determined to be 1000 which corresponds reasonably well to [NiFe(BAA)₂en]₂O, mol wt 1102. The room-temperature Mössbauer spectrum exhibits a broad resonance whose chemical shift with respect to sodium nitroprusside is 0.65 ± 0.2 mm/s. This chemical shift value is characteristic of Fe(III) with $S = 5/2$, which is also consistent with the presence of an oxo bridge. Under these room-temperature conditions, no fine structure was observed.

The magnetic properties of NiFe(BAA)₂en are also indicative of oxo-bridged Fe(III). The room-temperature magnetic moment of 2.0 μ_B which decreases to 1.0 μ_B at 77 K (Table V) is very similar to proven oxo-bridged high-spin Fe(III) complexes.¹⁹ The rapid decrease in the magnetic moment as the temperature is lowered is caused by strong antiferromagnetic coupling between the two Fe(III) atoms. Thus, although the structure has not been determined, analytical, infrared, molecular weight, Mössbauer, and magnetic susceptibility results are all explainable on the basis of the formula [NiFe(H₂O)(BAA)₂en]₂O in which Fe(III) is coordinated to four ketonic oxygens, one oxygen from a water molecule, and a bridging O²⁻.

The magnetic properties of the binuclear complexes presented in Table V give some interesting insights into the structures of the solids. All the values are explainable by assuming that the Ni(II) ion is coordinated in a square-planar manner and is diamagnetic with the entire paramagnetism arising from the second metal ion. On this basis, the magnetic properties of NiVO(BAA)₂en, NiCu(BAA)₂en, and NiNi(BAA)₂en(py)₂ are as expected for isolated d¹, d⁹ and octahedral d⁸ ions, respectively. The explanation for the

magnetic properties of NiCo(BAA)₂en·CH₃OH and NiNi(BAA)₂en·CH₃OH is not quite so straightforward. The room-temperature moments of 4.92 and 3.17 μ_B, respectively, are clearly indicative of octahedral coordination about the -O₂O₂ coordinated metal. However, it is not known with certainty what atoms occupy the fifth and sixth coordination sites. If the methanol is coordinated, the generalized structure is probably

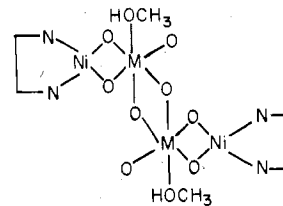

If the methanol is not coordinated, the results can be explained by a higher degree of oligomerization. It is likely that a similar situation pertains for NiMn(BAA)₂en·CH₃OH; however, for d⁵ Mn(II) there is no compelling reason to assume distorted octahedral geometry although it is intuitively logical.

The magnetic moments of NiNi(BAA)₂en·CH₃OH and NiNi(BAA)₂en(py)₂ illustrate a point made earlier that Ni(II) in the -O₂O₂ environment would most likely achieve six-coordination either by solvent coordination or by oligomerization. Therefore, if appreciable quantities of the diamagnetic Ni(II) in the NiH₂(BAA)₂en ligand had changed positions, it would be readily detectable in the magnetic properties of NiM(BAA)₂en.

Acknowledgment. We acknowledge partial support of the National Science Foundation.

Registry No. NiH₂(BAA)₂en, 55998-67-9; CuH₂(BAA)₂en, 56550-32-4; VOH₂(BAA)₂en·(CH₃)₂CO, 59033-79-3; NiZn(BAA)₂en, 56027-75-9; NiZn(py)(BAA)₂en, 56027-78-2; NiCu(BAA)₂en, 55998-68-0; Ni₂(BAA)₂en, 59033-80-6; Ni₂(py)₂(BAA)₂en, 59033-81-7; NiCo(BAA)₂en, 59033-82-8; [NiFe(BAA)₂en(H₂O)]₂O, 59069-50-0; NiMn(BAA)₂en, 59033-83-9; NiVO(BAA)₂en, 56027-77-1.

Supplementary Material Available: Listing of structure factor amplitudes (9 pages). Ordering information is given on any current masthead page.

References and Notes

- B. Tomlonovic, D. Gavel, M. D. Glick, and R. L. Lintvedt, Abstracts, 170th National Meeting of the American Chemical Society, Chicago, Ill., 1975, No. INOR 174.
- B. Tomlonovic, R. L. Hough, M. D. Glick, and R. L. Lintvedt, *J. Am. Chem. Soc.*, **97**, 2925 (1975).
- R. H. Holm, G. W. Everett, Jr., and H. Chakavorty, *Prog. Inorg. Chem.*, **7**, 83 (1966).
- J. P. Fackler, Jr., *Prog. Inorg. Chem.*, **7**, 361 (1966).
- M. L. Miles, T. M. Harris, and C. R. Hauser, *J. Org. Chem.*, **30**, 1007 (1965).
- Chemical Abstract Service index nomenclature for the 1972-1976 collective index.
- R. L. Lintvedt, M. D. Glick, B. K. Tomlonovic, D. P. Gavel, and J. M. Kuszaj, *Inorg. Chem.*, preceding paper in this issue.
- H. St. Rade, *J. Phys. Chem.*, **77**, 424 (1973).
- L. N. Mulay, "Magnetic Susceptibility", Interscience, New York, N.Y., 1963.
- Local versions of the following programs were used: SYNCOR, W. Schmonsees' data reduction program; DACOR, D. Smith's data reduction program; FORDAP, A. Zalkin's Fourier program; ORFLS and ORFFE, W. Busing, K. Martin, and H. Levy's full-matrix least-squares and function and error programs; REFINER, J. J. Park's block-diagonal least-squares program; ORTEP, C. K. Johnson's plotting program; HFINDER, A. Zalkin's hydrogen atom finding program. An interactive graphics package written in our laboratory for a Data General NOVA-1200 computer and an Owens-Illinois Plasma Display Panel was used: M. D. Glick, T. J. Anderson, W. A. Butler, E. R. Corey, and R. J. Srodawa, *Comput. Chem.*, in press.
- Scattering factors for V(0) and other atoms were taken from J. A. Ibers and W. C. Hamilton, Ed., "International Tables for X-Ray Crystallography", Vol. IV, Kynoch Press, Birmingham, England, 1974.

- (12) C. H. MacGillivray and G. D. Rieck, Ed., "International Tables for X-Ray Crystallography", Vol. III, Kynoch Press, Birmingham, England, 1962.
- (13) R. H. Holm, *J. Am. Chem. Soc.*, **82**, 5632 (1960).
- (14) A. P. Ginsberg, R. C. Sherwood, R. W. Brookes, and R. L. Martin, *J. Am. Chem. Soc.*, **93**, 5927 (1971).
- (15) P. Hon, R. L. Belford, and C. E. Pfluger, *J. Chem. Phys.*, **43**, 3111 (1965).
- (16) P. Hon, R. L. Belford, and C. E. Pfluger, *J. Chem. Phys.*, **43**, 1323 (1965).
- (17) M. R. Litzon and T. R. Spalding, "Mass Spectrometry of Inorganic and Organometallic Compounds", American Elsevier, New York, N.Y., 1973, Chapter 11 and references therein.
- (18) K. Nakamoto, Y. Morimoto, and A. E. Martell, *J. Am. Chem. Soc.*, **83**, 4533 (1961).
- (19) K. S. Murray, *Coord. Chem. Rev.*, **12**, 1 (1974).

Contribution from the Department of Chemistry,
Wayne State University, Detroit, Michigan 48202

Complexes of Binucleating Ligands with Two Different Coordinating Environments. 2. Crystal and Molecular Structures of Two Heterobinuclear Complexes, NiZn(py)(BAA)₂en and NiVO(BAA)₂en

M. D. GLICK,* R. L. LINTVEDT,* D. P. GAVEL, and B. TOMLONOVIC

Received February 19, 1975

AIC601378

The crystal structures of two heterobinuclear chelates containing the Schiff base ligand derived from ethylenediamine and 1-phenyl-1,3,5-hexanetrione, abbreviated H₄(BAA)₂en, have been determined by single-crystal x-ray techniques. The first compound, NiZn(py)(BAA)₂en, crystallizes in the space group *I2/c* with unit cell dimensions of $a = 28.403$ (6) Å, $b = 8.465$ (3) Å, $c = 30.220$ (9) Å, $\beta = 108.86$ (2)°, and $Z = 8$. The second compound, NiVO(BAA)₂en, crystallizes in the space group *P2₁/c* with unit cell dimensions of $a = 11.923$ (3) Å, $b = 15.868$ (4) Å, $c = 13.048$ (7) Å, $\beta = 102.93$ (3)°, and $Z = 4$. In both cases, the Ni(II) is coordinated to two nitrogens and two ketonic oxygens in a square-planar manner with bond lengths and angles similar to related Schiff base and macrocyclic complexes. The second metal, Zn or V, is coordinated to four ketonic oxygens, two of which are also bonded to the Ni atom. In addition, the Zn is bonded to a pyridine nitrogen and the V to a vanadyl oxygen. The environments of both Zn and V are very similar to those found in analogous 1,3-diketone chelates.

Introduction

In previous papers we have reported the structural and magnetic properties of homobinuclear metal complexes of 1,3,5-triketone type ligands.¹⁻³ The structural studies reported to date include a binuclear chelate of Co(II),¹ one of Ni(II),² and three of Cu(II).^{3,4} One fundamental reason for the interest in this system stems from the strong magnetic superexchange between the metal ions, which are connected by bridging ketonic oxygens. Since the mechanism of superexchange interactions is believed to depend upon the value of the M-O-M bridging angle, structural information is imperative in a discussion of the magnetism. In all of the binuclear chelates studied to date the bridging M-O-M angles are very close to 103° and the magnetic exchange is strongly antiferromagnetic. In the ethylenediamine Schiff base derivatives of 1,3,5-triketone chelates, the constraints of the diamine might be expected to cause a variation in the M-O-M angle and a resultant change in the magnetic properties. The structural studies of the Schiff base diamine 1,3,5-triketone chelates were initially undertaken to investigate the relation between bridging angles and magnetic exchange interactions.

In the previous paper in this series⁵ we described the synthesis and characterization of a number of heterobinuclear complexes containing Schiff base 1,3,5-triketone type ligands. In this paper we report the crystal and molecular structures of two heterobinuclear complexes, NiVO(BAA)₂en and NiZn(py)(BAA)₂en. The preliminary structure of NiZn(py)(BAA)₂en has been communicated.⁶

Experimental Section

I. Synthesis. Syntheses of the ligand³ and the complexes⁵ have been presented in previous papers.

II. Structure Determination. 1. [μ -[[5,5'-(1,2-Ethanediyldinitrilo)bis[1-phenyl-1,3-hexanedionato]](4-)-N³,N^{3'},O³,O^{3'}:O¹,O^{1'},O³,O^{3'}]](nickel)pyridinezinc-Dipyridine, NiZn(py)(BAA)₂en·2py. The three-dimensional single-crystal structure determination was carried out on crystals obtained by the recrystallization of NiZn(BAA)₂en

from pyridine. Since the dark red-brown crystals decomposed on extended exposure to the air, they were sealed in a capillary with a touch of the mother liquor to maintain crystal stability. The flat platelike crystal used for data collection had the dimensions 0.6 × 0.15 × 0.075 mm. Crystal instability precluded an accurate density measurement. Qualitative determinations with an aqueous saturated potassium tartrate solution and with carbon tetrachloride placed the experimental density between 1.4 and 1.6 g/cm³. The calculated density is 1.501 g/cm³.

Rotation and axial photographs of the crystal on a Syntex P₂₁ four-circle diffractometer, together with a small set of counter data, were consistent with the monoclinic space groups *I2/c* and *Ic*. Fifteen reflections with 2θ between 15 and 22° were centered using a programmed centering routine. The cell constants and errors obtained by a least-squares refinement of these angles were $a = 28.403$ (6) Å, $b = 8.465$ (3) Å, $c = 30.220$ (9) Å, $\beta = 108.86$ (2)°, $V = 6989.2$ (32) Å³, and $Z = 8$. The nonconventional *I*-centered cell was used to maintain β as close to 90° as possible and thus reduce correlations. The direct cell transformation

$$\begin{bmatrix} 101 \\ 010 \\ -100 \end{bmatrix}$$

yields the conventional cell with symmetry *C2/c* and lattice constants $a = 34.129$ Å, $b = 8.465$ Å, $c = 28.403$ Å, and $\beta = 123.08$ °.

Intensity data were collected using Mo K α radiation which had diffracted from a highly oriented graphite crystal whose diffraction vector was parallel to the diffraction vector of the sample. The θ -2θ scan technique was used with a scan speed inversely proportional to the peak height and ranging between 1.5 and 14°/min. The 2θ scan range was K α_1 - 1.0° to K α_2 + 1.0° and the ratio of the total background time to scan time was 1.0. During data collection, the intensities of four standard reflections were measured every 100 reflections, with no indication of decomposition. Independent data totaling 5055 reflections were collected to $(\sin \theta)/\lambda < 0.54$. Standard deviations⁷ of intensities were assigned as $\sigma(I) = [\sigma_{\text{counter}} + (pI)^2]^{1/2}$ where $\sigma_{\text{counter}} = (I + K^2B)^{1/2}$, I is the net intensity, B is the total background counts, K is the ratio of scan time to background time, and p is an instability factor equal to 0.05 in this case. No extinction or absorption corrections was applied. A total of 2562 data with I