

**Reduction of  $(\text{CO})_5\text{Mn}(\text{COC}_6\text{H}_5)$ .** To 2 mmol of  $\text{HMn}(\text{CO})_5$  prepared by procedure A was added a solution of 2 mmol (0.600 g) of  $(\text{CO})_5\text{Mn}(\text{COC}_6\text{H}_5)$  in 10 mL of THF. After 10 min, the solvent was removed on a rotovap and the residue chromatographed on a silica gel column with 10% ethyl acetate in hexane (v/v).  $\text{Mn}_2(\text{CO})_{10}$  was obtained in 86% yield (0.671 g, 1.72 mmol). In a similar run, the reaction residue was treated with 2,4-dinitrophenylhydrazine according to a standard procedure.<sup>23</sup> Subsequently isolated was the 2,4-dinitrophenylhydrazone of benzaldehyde (mp 238–239 °C; 0.569 g, 99% yield).

**$\text{HMn}(\text{CO})_5$  by Procedure B.** To 0.98 g (1.34 mmol) of  $\text{PP-N}[\text{Mn}(\text{CO})_5]$  in 80 mL of THF was added 0.13 mL (1.51 mmol) of  $\text{CF}_3\text{SO}_3\text{H}$ . By use of the Schlenk apparatus in Figure 1, a spectroscopic yield of 100% was determined. After the addition of 0.512 g (1.34 mmol) of  $(\text{C}_6\text{H}_5)_2\text{PCH}_2\text{P}(\text{C}_6\text{H}_5)_2$  to the above reaction mixture and 24 h of stirring, a 54% yield of *fac*- $\text{HMn}(\text{CO})_3\text{-}[(\text{C}_6\text{H}_5)_2\text{PCH}_2(\text{C}_6\text{H}_5)_2]$  was isolated by the procedure described previously.

**$\text{HMn}(\text{CO})_5$  by Procedure C.** To a 5-mm NMR tube containing  $(\text{CH}_3)_3\text{Si}[\text{Mn}(\text{CO})_5]$  (0.127 g, 0.473 mmol) and *p*-*tert*-butylbenzene (0.0045 g, 0.024 mmol) was added dry methanol (0.0155 g, 0.484 mmol). The mixture was shaken until it was homogeneous and kept at 35 °C for 8 h.  $\text{HMn}(\text{CO})_5$  was formed in >97% yield by <sup>1</sup>H NMR. In normal preparative runs, the *p*-*tert*-butylbenzene standard was omitted. Solvents which have been added after the methanolysis is complete include THF, benzene, and acetone.

The sample of  $\text{HMn}(\text{CO})_5$  prepared above was cooled to –78 °C and allowed to warm to room temperature under vacuum. Benzene-*d*<sub>6</sub> (0.50 mL) was then added. The <sup>1</sup>H NMR spectrum showed that 87% of the  $\text{HMn}(\text{CO})_5$  and 24% of the  $(\text{CH}_3)_3\text{SiOCH}_3$  remained. This experiment establishes that with proper vacuum line fractionation techniques,  $\text{HMn}(\text{CO})_5$  should be easily separable from  $(\text{CH}_3)_3\text{SiOCH}_3$ .

**Acknowledgment.** Acknowledgment is made to the donors of the Petroleum Research Fund, administered by the American Chemical Society, for support of this research through 1977. We thank the Department of Energy for subsequent funding.

**Registry No.** 1, 36344-24-8;  $\text{HMn}(\text{CO})_5$ , 16972-33-1;  $\text{Mn}_2(\text{CO})_{10}$ , 10170-69-1;  $\text{PPN}[\text{Mn}(\text{CO})_5]$ , 52542-59-3;  $(\text{CH}_3)_3\text{Si}[\text{Mn}(\text{CO})_5]$ , 26500-16-3;  $(\text{CO})_5\text{Mn}(\text{COC}_6\text{H}_5)$ , 15612-92-7;  $\text{Li}[\text{Mn}(\text{CO})_5]$ , 15689-01-7;  $\text{Li}(\text{C}_2\text{H}_5)_3\text{BH}$ , 22560-16-3;  $\text{CF}_3\text{SO}_3\text{H}$ , 1493-13-6;  $\text{CH}_3\text{OH}$ , 67-56-1.

## References and Notes

- H. D. Kaesz and R. B. Saillant, *Chem. Rev.*, **72**, 231 (1972).
- E. L. Muetterties, Ed., "Transition Metal Hydrides", Marcel Dekker, New York, 1971.
- E. A. McNeill and F. R. Scholer, *J. Am. Chem. Soc.*, **99**, 6243 (1977).
- P. S. Ireland, C. A. Deckert, and T. L. Brown, *J. Magn. Reson.*, **23**, 485 (1976).
- W. F. Edgell, J. W. Fischer, G. Asato, and W. M. Risen, *Inorg. Chem.*, **8**, 1103 (1969).
- B. H. Byers and T. L. Brown, *J. Organomet. Chem.*, **127**, 181 (1977); *J. Am. Chem. Soc.*, **99**, 2527 (1977).
- W. Beck and W. Danzen, *Z. Naturforsch., B*, **30**, 716 (1975), and references therein.
- W. A. Herrman, M. L. Ziegler, K. Weidenhammer, H. Biersack, K. K. Mayer, and R. D. Minard, *Angew. Chem., Int. Ed. Engl.*, **15**, 164 (1976).
- K. D. Bos, E. J. Bulten, J. G. Noltes, and A. L. Spek, *J. Organomet. Chem.*, **92**, 33 (1975).
- J. Grobe and R. Rau, *Z. Anorg. Allg. Chem.*, **414**, 19 (1975).
- B. L. Booth and R. G. Hargreaves, *J. Chem. Soc. A*, 2766 (1969).
- (a) F. W. Einstein, E. Enwall, N. Flitcroft, and J. M. Leach, *J. Inorg. Nucl. Chem.*, **34**, 885 (1972); (b) G. L. Booth and R. N. Haszeldine, *J. Chem. Soc. A*, 157 (1966).
- R. L. Sweany and J. Halpern, *J. Am. Chem. Soc.*, **99**, 8335 (1977).
- (a) R. B. King, "Organometallic Syntheses", Vol. 1, Academic Press, New York, 1965, p 158; (b) R. B. King and F. G. H. Stone, *Inorg. Synth.*, **7**, 198 (1963).
- W. Hieber and G. Wagner, *Z. Naturforsch., B*, **12**, 478 (1957); **13**, 339 (1958).
- (a) J. A. Gladysz, G. M. Williams, W. Tam, and D. L. Johnson, *J. Organomet. Chem.*, **140**, C1 (1977). (b) J. A. Gladysz, G. M. Williams, W. Tam, D. L. Johnson, D. W. Parker, and J. C. Selover, *Inorg. Chem.*, **18**, 553 (1979).
- Sold by the Aldrich Chemical Co. as a 1 M THF solution under the trade name Super Hydride.
- R. D. Howells and J. D. McCown, *Chem. Rev.*, **77**, 69 (1977).
- A. D. Berry and A. G. MacDiarmid, *Inorg. Nucl. Chem. Lett.*, **5**, 601 (1969). W. Malisch and M. Kuhn, *Chem. Ber.*, **107**, 979 (1974).

- T. C. Flood, E. Rosenberg, and A. Sarhangi, *J. Am. Chem. Soc.*, **99**, 4334 (1977).
- R. D. Closson, J. Kozikowski, and T. H. Coffield, *J. Org. Chem.*, **22**, 598 (1957).
- R. L. Shriner, R. C. Fuson, and D. Y. Curtin, "The Systematic Identification of Organic Compounds", 5th ed., Wiley, New York, 1964, pp 253–254.

Contribution from the Istituto di Chimica Generale, University of Pisa, 56100 Pisa, Italy, and Istituto di Chimica Generale, University of Parma, Centro di Studio per la Strutturistica Diffraattometrica del CNR, 43100 Parma, Italy

## The Reaction of Nucleophiles with *cis*- $\text{PtCl}_2(\text{CO})_2$ . 1. Crystal and Molecular Structure of the Carbamoyl Complex Derived from the Reaction with Diisopropylamine

Daniela Belli Dell'Amico,<sup>1</sup> Fausto Calderazzo,<sup>\*1</sup> and Giancarlo Pelizzi<sup>2</sup>

Received July 20, 1978

It has been pointed out<sup>3</sup> that metal carbonyls having force constants higher than 17.2 mdyn/Å should react with amines to give carbamoyl derivatives. We have recently reported<sup>4</sup> that *cis*- $\text{PtCl}_2(\text{CO})_2$  is characterized by two exceedingly high  $\nu_{\text{CO}}$ 's (2168 and 2127  $\text{cm}^{-1}$  in toluene, with force constants of 19.01 and 18.3 mdyn/Å, respectively), thus making this compound a particularly appropriate candidate to further test this proposal. In addition, due to the limited number of known platinum(II) carbonyl derivatives, no carbamoyl complexes of platinum have been reported which were obtained by the direct reaction of amines on an uncharged carbonyl compound of this metal.<sup>5</sup>

We want now to report that *cis*- $\text{PtCl}_2(\text{CO})_2$  reacts promptly with secondary amines in a ratio of 1:2 to give carbamoyl compounds. The molecular structure of the isopropyl derivative is presented in this paper.

## Experimental Section

Infrared spectra were measured with a Perkin-Elmer Model 283 instrument. Solvents were carefully dried by conventional methods and distilled prior to use. Diisopropylamine was distilled over sodium. Dichlorodicarbonylplatinum(II) was prepared according to the previously described<sup>4</sup> procedure. All operations were carried out under an atmosphere of prepurified nitrogen.

**Preparation of  $[\text{NH}_2\text{-}i\text{-Pr}_2]^+[\text{cis-PtCl}_2(\text{CON-}i\text{-Pr}_2)\text{CO}]^-$  (1).** The dicarbonyl derivative (1.17 g, 3.63 mmol) dissolved in 150 mL of toluene was treated with diisopropylamine (0.73 g, 7.21 mmol) dissolved in toluene (50 mL). After about 2 h, the resulting precipitate was filtered and dried in vacuo (1.04 g, 55% yield). Anal. Calcd for  $\text{C}_{14}\text{H}_{30}\text{Cl}_2\text{N}_2\text{O}_2\text{Pt}$ : C, 32.07; H, 5.77; Cl, 13.52. Found: C, 31.68; H, 6.09; Cl, 12.88. The colorless compound is sensitive to moisture and darkens in air. It is soluble in dichloromethane, slightly soluble in toluene, and very slightly soluble in heptane.

**X-ray Analysis, Data Collection, and Refinement of Structure.** The carbamoyl derivative (1) was recrystallized from a heptane–toluene mixture. Preliminary unit-cell dimensions and symmetry information were deduced from rotation and Weissenberg photographs. The crystals belong to the orthorhombic system, and their diffraction pattern exhibited the absences  $h0l$ ,  $l = 2n + 1$ ,  $hk0$ ,  $h = 2n + 1$ ,  $0kl$ ,  $k = 2n + 1$ , which are consistent with the *Pbca* space group. Accurate unit-cell parameters, with estimated standard deviations, were determined by a least-squares refinement of the  $2\theta$  values for 15 reflections measured on an "on-line" single-crystal automated Siemens diffractometer. Crystal data are as follows:  $a = 21.756$  (9) Å,  $b = 14.707$  (6) Å,  $c = 12.708$  (6) Å,  $V = 4066.1$  Å<sup>3</sup>,  $Z = 8$ ,  $D_{\text{calcd}} = 1.71$  g  $\text{cm}^{-3}$ ; Mo  $K\alpha$  radiation,  $\lambda$  0.71069 Å;  $\mu(\text{Mo}K\alpha) = 75.2$   $\text{cm}^{-1}$ ;  $F(000) = 2048$ .

Three-dimensional intensity data were taken at room temperature from a roughly prismatic crystal of approximate dimensions 0.15 ×

Table I. Final Atomic Coordinates ( $\times 10^5$  for Pt;  $\times 10^4$  for Cl;  $\times 10^3$  for O, N, and C) and Anisotropic Thermal Parameters<sup>a</sup> ( $\times 10^3$  for Pt and Cl;  $\times 10^2$  for O, N, and C) with Their Estimated Standard Deviations

atom	x	y	z	$U_{11}$	$U_{22}$	$U_{33}$	$U_{23}$	$U_{13}$	$U_{12}$
Pt	10726 (4)	2103 (6)	16352 (7)	47 (1)	27 (1)	42 (1)	-6 (1)	1 (1)	-3 (1)
Cl(1)	485 (5)	-1154 (6)	1366 (6)	118 (7)	60 (5)	54 (5)	-9 (4)	1 (4)	-61 (5)
Cl(2)	1122 (4)	-86 (5)	3404 (6)	94 (6)	45 (4)	50 (4)	-1 (3)	4 (4)	-23 (4)
O(1)	119 (1)	207 (1)	212 (1)	10 (2)	4 (2)	2 (1)	0 (1)	-1 (1)	1 (1)
O(2)	104 (1)	61 (2)	-62 (2)	12 (2)	8 (1)	7 (1)	-1 (1)	4 (1)	-3 (1)
N(1)	212 (1)	141 (1)	195 (2)	5 (1)	2 (1)	5 (1)	0 (1)	-1 (1)	-1 (1)
N(2)	8 (1)	219 (1)	662 (2)	5 (1)	4 (1)	5 (1)	0 (1)	2 (1)	1 (1)
C(1)	153 (1)	134 (2)	186 (2)	1 (1)	7 (2)	4 (1)	3 (1)	-3 (1)	1 (1)
C(2)	246 (1)	227 (2)	226 (2)	8 (2)	2 (1)	5 (2)	-2 (1)	-2 (2)	-1 (1)
C(3)	225 (2)	261 (2)	338 (3)	13 (3)	6 (2)	5 (2)	-1 (2)	-1 (2)	-1 (2)
C(4)	242 (2)	298 (2)	141 (3)	13 (3)	3 (2)	8 (3)	2 (2)	1 (2)	-1 (2)
C(5)	250 (1)	62 (2)	178 (2)	5 (1)	3 (1)	6 (2)	-2 (1)	0 (1)	2 (1)
C(6)	282 (2)	33 (2)	284 (3)	9 (3)	4 (2)	13 (3)	4 (2)	-5 (2)	0 (2)
C(7)	296 (1)	73 (2)	89 (3)	9 (2)	6 (2)	8 (2)	-1 (2)	1 (2)	2 (2)
C(8)	109 (1)	46 (2)	22 (2)	6 (1)	3 (1)	3 (1)	-1 (1)	1 (1)	0 (1)
C(9)	-38 (1)	294 (2)	630 (2)	4 (1)	3 (1)	6 (2)	0 (1)	1 (1)	-1 (1)
C(10)	-43 (1)	356 (2)	732 (2)	7 (2)	3 (1)	6 (2)	-1 (1)	0 (2)	-1 (1)
C(11)	-99 (1)	259 (2)	596 (2)	6 (2)	7 (2)	5 (2)	-1 (2)	0 (2)	1 (2)
C(12)	21 (1)	152 (2)	571 (2)	7 (2)	4 (1)	4 (2)	-2 (1)	-1 (1)	2 (1)
C(13)	61 (1)	77 (2)	619 (3)	9 (2)	4 (2)	10 (2)	0 (2)	-1 (2)	1 (2)
C(14)	59 (1)	202 (2)	485 (2)	10 (2)	5 (1)	4 (2)	2 (1)	2 (2)	-1 (2)

<sup>a</sup> The form of the thermal ellipsoid is  $\exp[-2\pi^2(U_{11}h^2a^{*2} + U_{22}k^2b^{*2} + U_{33}l^2c^{*2} + 2U_{23}klb^*c^* + \dots)]$ .

0.29  $\times$  0.47 mm, sealed in a Lindemann capillary and mounted with the direction of the maximum elongation collinear with the  $\phi$  axis of the diffractometer, Niobium-filtered Mo K $\alpha$  radiation at a takeoff angle of 4 $^\circ$  was employed. The moving-counter, moving-crystal scan technique was used, with a drive speed related to the number of counts on the peak (lowest speed 2.5 $^\circ$ /min). The pulse-height discriminator was set to accept 90% of the Mo K $\alpha$  peak. For intensities and background the "five-points" technique<sup>6</sup> was used. As a general check on crystal and electronic stability, the intensity of a standard reflection (704) was monitored every 20 reflections and was not found to vary significantly during the entire period of data collection. A total of 3581 independent reflections were collected over the range  $4.5 < 2\theta < 50.0^\circ$ ; of these, 2090 were used in the crystal analysis, considering the reflections with intensity greater than  $2[\sigma^2(I) + 0.25 \times 10^{-4}I^2]^{1/2}$ , where  $I$  is the relative intensity and  $\sigma^2(I)$  its variance, as being observed.

After the usual Lorentz and polarization reduction, the structure amplitudes were placed on an absolute scale, first by correlating observed and calculated values and then by determining the scale factor for the  $F_o$  values as a parameter in the least-squares refinement. No correction for absorption effects was made since the crystal faces were not well shaped, an accurate measurement of the crystal was not possible, and the absorbance of the sample was not particularly high ( $\mu_F \approx 0.8$ ).

The positions of the platinum and chlorine atoms were determined by a combination of Patterson synthesis and direct methods. After these positions were refined by a least-squares procedure, a difference Fourier map was computed from which all nonhydrogen atoms were located. Full-matrix least-squares refinement with isotropic models for all atoms gave an  $R$  factor of 13.0% for all observed reflections. Anisotropic refinement reduced the index to 9.16% ( $R = \sum |F_o| - |F_c| / \sum |F_o|$ ). In this way the ratio between observations and parameters was 11.0, a ratio greater than that usually accepted for structure analyses. It can be added that the fraction of significant reflections is a little low (ca. 60%); nevertheless, the agreement obtained for the structure factors of the reflections not used in the analysis indicates that the general accuracy is sufficiently good. The hydrogen atoms were not located. The function minimized was  $\sum w|\Delta F|^2$ ; unit weights were used at first, and in the last cycles the weighting scheme  $w = 1/(\sigma^2(F_o^2) + 0.005F_o^2)$  based on counting statistics was assumed. The final  $R$ 's (ignoring the contribution of nine reflections at low  $\theta$  having rather large  $|F_o - F_c|$  values and being excluded from the last cycle of refinement) are  $R = 8.08\%$  and  $R_w = 8.17\%$  ( $R_w = [\sum w(|F_o| - |F_c|)^2 / \sum wF_o^2]^{1/2}$ ). In this last cycle the ratio of the largest shift to standard deviation in coordinate was 1/3.5.

As a final check of the correctness of the structure a  $\Delta E$  map was computed. This revealed two peaks of height 2.4 and 2.2 e  $\text{\AA}^{-3}$  at distances 0.8  $\text{\AA}$  on either side of the platinum atom. These peaks are thought to arise because no absorption correction had been applied. No evidence for secondary extinction was found.

Neutral atom scattering factors were taken from Cromer and Mann.<sup>7</sup> Corrections for anomalous dispersion<sup>8</sup> were made by using the following values: Pt,  $\Delta f' = -2.352$ ,  $\Delta f'' = 8.388$ ; Cl,  $\Delta f' = 0.132$ ,  $\Delta f'' = 0.159$ .

Final atomic coordinates and thermal parameters are listed in Table I. A list of observed and calculated structure factors is available as supplementary material. All computations were performed using the SHELX 76 system of programs.<sup>9</sup>

## Results and Discussion

We have found that secondary amines  $R_2NH$  ( $R = \text{Me, Et, } i\text{-Pr}$ ) react promptly with *cis*-PtCl<sub>2</sub>(CO)<sub>2</sub> to give products containing carbamoyl groups. Only in the case of the molar ratio  $[R_2NH]/[Pt] = 2$  and with  $R = i\text{-Pr}$  was it possible to isolate a solid compound which gave reproducible infrared and analytical data and which was amenable for an X-ray investigation:

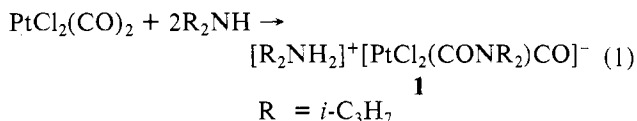

A strict control of the stoichiometry is necessary since at lower or higher  $R_2NH$ :Pt ratios other platinum(II) complexes are obtained, which are now under investigation. The compound resulting from reaction 1 is characterized by one carbonyl stretching vibration at 2081  $\text{cm}^{-1}$  ( $\text{CH}_2\text{Cl}_2$  solution) which is to be attributed to the unique terminal CO group and by another band at 1550  $\text{cm}^{-1}$  for the carbamoyl carbonyl group. The observed value for the terminal CO group is well within the range of values encountered in the literature for anionic monocarbonyl derivatives of platinum(II) such as, for example,  $[\text{PtCl}_3(\text{CO})]^-$  (2180  $\text{cm}^{-1}$  in  $\text{CHCl}_3$ <sup>10</sup>). Also the value of the carbamoyl carbonyl stretching vibration is consistent with the reported<sup>5</sup> infrared bands for other uncharged carbamoyl derivatives of platinum(II).

The crystal structure is built up from  $[\text{PtCl}_2(\text{CONR}_2)\text{CO}]^-$  anions and  $\text{H}_2\text{NR}_2^+$  cations held together by  $\text{NH}\cdots\text{O}$ (carbamoyl) and  $\text{NH}\cdots\text{Cl}$  hydrogen bonds. Bond distances and angles are presented in Table II.

The anion has the expected square-planar coordination around platinum, two *cis* positions being occupied by the chlorine atoms, one by a carbonyl group, and the fourth one by the carbamoyl group (Figure 1). A slight distortion of the square coordination can be observed. The deviations ( $\text{\AA}$ )

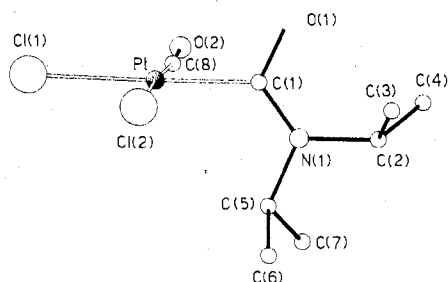

Figure 1. Perspective view of the  $[\text{PtCl}_2(\text{CON-}i\text{-Pr}_2)(\text{CO})]^-$  anion.

Table II. Bond Distances (Å) and Angles (deg)

(a) In the Anion			
Distances			
Pt-Cl(1)	2.404 (9)	Pt-C(1)	1.96 (2)
Pt-Cl(2)	2.293 (8)	Pt-C(8)	1.84 (2)
C(1)-O(1)	1.36 (3)	C(2)-C(4)	1.51 (4)
C(1)-N(1)	1.30 (3)	C(5)-C(6)	1.57 (5)
N(1)-C(2)	1.52 (3)	C(5)-C(7)	1.52 (4)
N(1)-C(5)	1.44 (3)	C(8)-O(2)	1.10 (3)
C(2)-C(3)	1.57 (4)		
Angles			
Cl(1)-Pt-Cl(2)	90.3 (5)	Cl(2)-Pt-C(1)	90 (1)
Cl(1)-Pt-C(1)	178 (1)	Cl(2)-Pt-C(8)	176 (1)
Cl(1)-Pt-C(8)	92 (1)	C(1)-Pt-C(8)	88 (2)
Pt-C(1)-O(1)	115 (3)	N(1)-C(2)-C(4)	111 (4)
Pt-C(1)-N(1)	126 (3)	C(3)-C(2)-C(4)	114 (4)
O(1)-C(1)-N(1)	118 (4)	N(1)-C(5)-C(6)	110 (4)
C(1)-N(1)-C(2)	125 (4)	N(1)-C(5)-C(7)	113 (4)
C(1)-N(1)-C(5)	119 (4)	C(6)-C(5)-C(7)	112 (5)
C(2)-N(1)-C(5)	115 (4)	Pt-C(8)-O(2)	173 (3)
N(1)-C(2)-C(3)	111 (4)		
(b) In the Cation			
Distances			
N(2)-C(9)	1.55 (3)	N(2)-C(12)	1.55 (3)
C(9)-C(10)	1.59 (4)	C(12)-C(13)	1.53 (4)
C(9)-C(11)	1.49 (4)	C(12)-C(14)	1.56 (4)
Angles			
C(9)-N(2)-C(12)	112 (4)	N(2)-C(12)-C(13)	105 (4)
N(2)-C(9)-C(10)	104 (3)	N(2)-C(12)-C(14)	109 (4)
N(2)-C(9)-C(11)	114 (4)	C(13)-C(12)-C(14)	109 (4)
C(10)-C(9)-C(11)	112 (4)		

from the weighted best least-squares plane, calculated through Pt, Cl(1), Cl(2), C(1), and C(8) are as follows: Pt, -0.01; Cl(1), -0.01; Cl(2), 0.00; C(1), -0.05; C(8), 0.08. The two Pt-Cl bonds differ by 0.11 Å. The shorter one (2.293 Å) is in good agreement with those usually found in platinum(II) complexes.<sup>11</sup> The longer bond (2.404 Å), which is trans to the Pt-C(carbamoyl) bond, involves the chlorine atom Cl(1) forming a rather strong hydrogen bond with the nitrogen atom of the cation. The unusually long Pt-Cl(1) bond distance should therefore be attributed to the presence of the hydrogen bonding.

As far as the Pt-CO group is concerned, a comparison with the known structures of carbonyl derivatives of platinum(II) is reported in Table III. The values of the Pt-C and C-O

distances and that of the Pt-C-O bond angle are well in agreement with the corresponding data reported<sup>18</sup> for the similar anionic complex  $[\text{PtCl}_3(\text{CO})]^-$ .

To the best of our knowledge, only one C-bonded carbamoyl metal complex has been studied by X-ray diffraction methods, namely,  $\text{Mn}(\text{CO})_4(\text{CONHMe})(\text{NH}_2\text{Me})$ , which occurs in two modifications, tetragonal<sup>19</sup> and monoclinic.<sup>20</sup> In our compound, as in the manganese case, the carbonyl group is coordinated to the central metal atom only through carbon, a situation which is different from that encountered more frequently<sup>21-26</sup> with thiocarbamoyl derivatives of transition elements, which are usually both C- and S-bonded to the metal. On the other hand, spectroscopic evidence exists for the presence of monodentate, C-bonded thiocarbamoyl groups attached to palladium and platinum.<sup>5</sup> The C(1)-O(1)-N(1)-C(2)-C(5) system is planar within experimental error with all atoms lying within 0.05 Å of the mean least-squares plane and with platinum displaced by 0.11 Å from this plane. The C(1)-O(1)-N(1)-C(2)-C(5) system is almost perpendicular to the coordination plane (88.1°). The planarity of this system as well as the values of the bond angles at C(1) and N(1), all close to 120°, indicates that these two atoms are essentially  $\text{sp}^2$  hybridized.

The atomic coordinates for light atoms in structures containing atoms as heavy as platinum suffer for low accuracy, so the structural parameters show a low degree of reliability and a full discussion based on them cannot be made. Accordingly, little significance can be attached to the C(1)-O(1) bond distance, 1.36 Å, which is surprisingly long. It is, however, to be noted that the C-O distance in the manganese analogue<sup>19</sup> is 1.25 Å and that the C-O distance in acyl derivatives of transition elements<sup>27</sup> is between 1.18 and 1.22 Å. What appears to be a likely weakening of this bond could be explained by its implication in the hydrogen bonding to the diisopropylammonium cation. On the contrary, it is to be observed that the Pt-C(carbamoyl) bond distance of 1.96 Å lies at the lower limit of the values observed for platinum-carbon  $\sigma$  bonds in square-planar platinum(II) derivatives; e.g., the Pt-C distance in a Pt-Me derivative is 2.028 (13) Å<sup>16</sup> and it is 2.086 Å in a Pt-CH<sub>2</sub> grouping.<sup>28</sup>

Bond lengths and angles in the cation are unexceptional considering the accuracy of the analysis and are in agreement with the  $\text{sp}^3$  hybridization of all the atoms.

The packing arrangement in the structure is illustrated in Figure 2. The amino group of the cation is involved in hydrogen bonding with two adjacent anions, through the oxygen atom from the CONR<sub>2</sub> moiety and a chloride ion, respectively:  $\text{N}(2)\cdots\text{O}(1)$  ( $x, \frac{1}{2} - y, \frac{1}{2} + z$ ) = 2.72 (3) Å,  $\text{N}(2)\cdots\text{Cl}(1)$  ( $\bar{x}, \bar{y}, 1 - z$ ) = 3.22 (2) Å.

The other contacts responsible for the crystal packing can be considered as normal van der Waals interactions; the most significant of them are as follows:  $\text{C}(9)\cdots\text{O}(1)$  ( $x, \frac{1}{2} - y, \frac{1}{2} + z$ ) = 3.57 (3) Å,  $\text{C}(9)\cdots\text{Cl}(1)$  ( $\bar{x}, \frac{1}{2} + y, \frac{1}{2} - z$ ) = 3.65 (2) Å,  $\text{C}(12)\cdots\text{O}(1)$  ( $x, \frac{1}{2} - y, \frac{1}{2} + z$ ) = 3.47 (3) Å,  $\text{C}(11)\cdots\text{Cl}(1)$  ( $\bar{x}, \frac{1}{2} + y, \frac{1}{2} - z$ ) = 3.65 (2) Å,  $\text{C}(14)\cdots\text{O}(1)$  ( $x, \frac{1}{2} - y, \frac{1}{2} + z$ ) = 3.44 (3) Å,  $\text{C}(6)\cdots\text{O}(2)$  ( $\frac{1}{2} - x, \bar{y}, \frac{1}{2} + z$ ) = 3.44 (4) Å.

Table III. Bond Distances (Å) and Angles (deg) for the Pt-CO Moiety of Platinum(II) Carbonyl Compounds

compd	Pt-C	C-O	Pt-C-O	ref
$[\text{PtCl}(\text{CO})(\text{PEt}_3)_2]^+[\text{SiF}_6]^-$	1.78	1.14		12
$[\text{Pt}(p\text{-ClC}_6\text{H}_4)_2(\text{CO})(\text{PEt}_3)_2]^+[\text{PF}_6]^-$	1.97 (5)	1.06 (6)	171 (5)	13
$\text{PtCl}_2(\text{CO})(4\text{-OMe(py)O})^a$	1.74 (4)	1.16 (4)	178 (3)	14
$\text{Pt}[\text{BH}(\text{C}_3\text{H}_3\text{N}_2)_3](\text{Me})\text{CO}$	1.81 (1)			16
$\text{PtCl}_2(\text{CO})\text{PPh}_3$	1.85 (1)		180 (3)	11
$\text{PtCl}_2(\text{CO})(\text{PEt}_3)$	1.855 (14)	1.124 (19)	176.5 (12)	17
$[\text{Bu}_4\text{N}]^+[\text{PtCl}_3(\text{CO})]^-$	1.82 (1)	1.12 (2)	178 (2)	18
$[\text{H}_2\text{N-}i\text{-Pr}_2]^+[\text{PtCl}_2(\text{CON-}i\text{-Pr}_2)(\text{CO})]^-$	1.84 (2)	1.10 (3)	173 (3)	this work

<sup>a</sup> 4-Methoxypyridine 1-oxide.

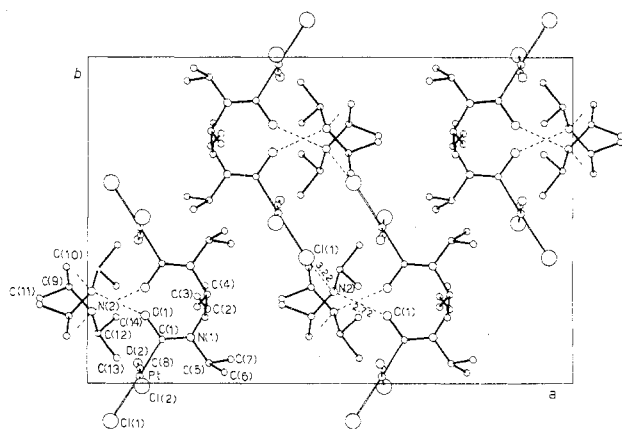

**Figure 2.** Diagrammatic projection of the structure along [001] showing crystal packing.

The chemical properties of the compound reported in this paper are well in agreement with its molecular structure. In particular it is to be noted that, while the carbamoyl derivative is little soluble in hydrocarbon solvents, it is readily soluble in dichloromethane, certainly as a result of the breaking of  $\text{NH}\cdots\text{C}1$  and  $\text{NH}\cdots\text{O}$  hydrogen bonds.

It is believed that the formation of **1** may arise from a direct nucleophilic attack of the amine on coordinated carbon monoxide. This may lead to the formation of an intermediate carbene-type<sup>29</sup> of complex (**2**), followed by deprotonation by the second molecule of amine and precipitation of the salt-like carbamoyl derivative:

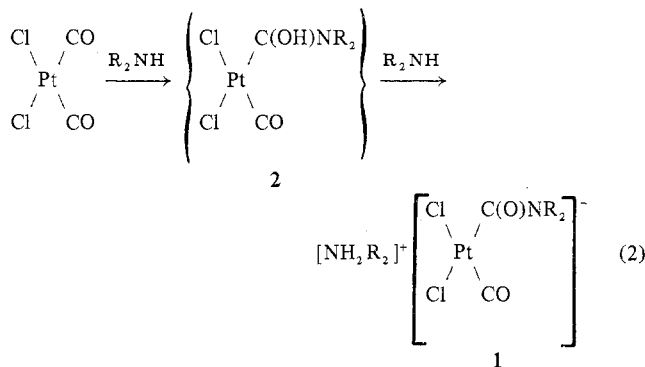

**Acknowledgment.** The authors thank the National Research Council (CNR, Rome) for support, the Consorzio per la Gestione del Centro di Calcolo Elettronico Interuniversitario dell'Italia Nord-Orientale, Casalecchio, Bologna, for computing facilities, and Chimet S.P.A., Badia al Pino, Arezzo, for platinum chlorides.

**Registry No.** **1**, 69069-34-7; *cis*-PtCl<sub>2</sub>(CO)<sub>2</sub>, 15020-32-3; NH-*i*-Pr<sub>2</sub>, 108-18-9.

**Supplementary Material Available:** A listing of observed and calculated structure factors (15 pages). Ordering information is given on any current masthead page.

## References and Notes

- (1) University of Pisa.
- (2) University of Parma.
- (3) R. J. Angelici, *Acc. Chem. Res.*, **5**, 335 (1972).
- (4) D. Belli Dell'Amico, F. Calderazzo, and G. Dell'Amico, *Gazz. Chim. Ital.*, **107**, 101 (1977).
- (5) C. R. Green and R. J. Angelici, *Inorg. Chem.*, **11**, 2095 (1972).
- (6) W. Hoppe, *Acta Crystallogr., Sect. A*, **25**, 67 (1969).
- (7) D. T. Cromer and J. B. Mann, *Acta Crystallogr., Sect. A*, **24**, 321 (1968).
- (8) "International Tables for X-Ray Crystallography", Vol. IV, Kynoch Press, Birmingham, England, 1974, pp 149-150.
- (9) G. M. Sheldrick, "SHELX 76. A Program for Crystal Structure Determination", University of Cambridge, Cambridge, England, 1976.
- (10) C. Valentini, Doctoral Thesis, University of Pisa, June 1975.
- (11) L. Manojlović-Muir, K. W. Muir, and R. Walker, *J. Organomet. Chem.*, **66**, C21 (1974).

- (12) H. C. Clark, P. W. R. Corfield, K. R. Dixon, and J. A. Ibers, *J. Am. Chem. Soc.*, **89**, 3360 (1967).
- (13) J. S. Field and P. J. Wheatley, *J. Chem. Soc., Dalton Trans.*, 702 (1974).
- (14) Results by R. S. Hamilton and E. R. Corey; quoted from ref 12.
- (15) M. Orchin and P. J. Schmidt, *Coord. Chem. Rev.*, **3**, 345 (1968).
- (16) P. E. Rush and J. D. Oliver, *J. Chem. Soc., Chem. Commun.*, 996 (1974).
- (17) L. Manojlović-Muir, K. W. Muir, and T. Solomon, *J. Organomet. Chem.*, **142**, 265 (1977).
- (18) D. R. Russell, P. A. Tucker, and S. Wilson, *J. Organomet. Chem.*, **104**, 387 (1976).
- (19) D. M. Chipman and R. A. Jacobson, *Inorg. Chim. Acta*, **1**, 393 (1967).
- (20) G. L. Breneman, D. M. Chipman, C. J. Galles, and R. A. Jacobson, *Inorg. Chim. Acta*, **3**, 447 (1969).
- (21) L. Ricard, J. Estienne, and R. Weiss, *Inorg. Chem.*, **12**, 2182 (1973).
- (22) W. P. Bosman and A. W. Gal, *Cryst. Struct. Commun.*, **4**, 465 (1975).
- (23) W. P. Bosman and A. W. Gal, *Cryst. Struct. Commun.*, **5**, 703 (1976).
- (24) W. K. Dean, J. B. Wetherington, and J. W. Moncrief, *Inorg. Chem.*, **15**, 1566 (1976).
- (25) W. K. Dean, R. S. Charles, and D. G. van Derveer, *Inorg. Chem.*, **16**, 3328 (1977).
- (26) W. K. Dean and D. G. van Derveer, *J. Organomet. Chem.*, **144**, 65 (1978).
- (27) F. Calderazzo, *Angew. Chem.*, **89**, 305 (1977).
- (28) A. De Renzi, B. Di Blasio, G. Paiaro, A. Panunzi, and C. Pedone, *Gazz. Chim. Ital.*, **106**, 765 (1976).
- (29) M. L. H. Green, L. C. Mitchard, and M. G. Swanwick, *J. Chem. Soc. A*, 794 (1971).

Contribution from the Department of Chemistry, Stanford University, Stanford, California 94305

## Pentaammineruthenium Dimethyl Chalcogenide Complexes

Cy A. Stein and Henry Taube\*

Received September 22, 1978

The synthesis of  $[(\text{NH}_3)_5\text{RuS}(\text{CH}_3)_2]^{2+}$  (and of closely related complexes) has been reported,<sup>1</sup> as well as some of its properties, but the corresponding ruthenium(III) complex has been less completely characterized. We report here a continuation of studies on the pentaammineruthenium(II) and -(III) complexes of  $(\text{CH}_3)_2\text{S}$  and the synthesis and characterization of the species with  $(\text{CH}_3)_2\text{Se}$  and  $(\text{CH}_3)_2\text{Te}$  as ligands.

## Experimental Section

The general preparative procedures have been described elsewhere.<sup>1</sup> In fact, the synthesis of the pentaammineruthenium(II) complexes of  $(\text{CH}_3)_2\text{S}$  and  $(\text{CH}_3)_2\text{Se}$  in solution followed the method outlined there for the former ligand. Solid  $\text{NH}_4\text{PF}_6$  was used as precipitant and the product, in each case yellow, was obtained in 60% yield. The method was not successful for  $(\text{CH}_3)_2\text{Te}$  owing to decomposition of the ligand and to labilization by it of coordinated  $\text{NH}_3$ . A pure compound was prepared in 85% yield by allowing a fivefold excess of  $(\text{CH}_3)_2\text{Te}$  to react for 30 min with 100 mg of freshly prepared  $[(\text{NH}_3)_5\text{Ru}(\text{OH}_2)](\text{PF}_6)_2$  in 7 mL of deaerated acetone. On addition the mixture to 40 mL of peroxide-free ether, a yellow solid resulted. This was filtered and washed with ether and dried in vacuo. Anal. Calcd for  $\text{C}_2\text{H}_{21}\text{N}_5\text{RuSe}(\text{PF}_6)_2$ : C, 4.10; H, 3.62; N, 11.97; Se, 13.49; Ru, 17.28; F, 38.96. Found: C, 3.90; H, 3.42; N, 11.96; Se, 13.1; Ru, 17.6; F, 39.5. Calcd for  $\text{C}_2\text{H}_{21}\text{N}_5\text{RuTe}(\text{PF}_6)_2$ : C, 3.79; H, 3.34; N, 11.05; Ru, 15.95; F, 35.97. Found: C, 4.15; H, 3.41; N, 10.61; Ru, 15.9; F, 35.5.

Analyses were not performed on the dimethyl sulfide complex, but the identity of the product was confirmed by comparing the spectrum with that reported earlier.<sup>1</sup> The agreement was excellent (within 2% of the value of  $\epsilon$  at the maximum).

Solids containing the complexes with ruthenium in the 3+ oxidation state were not prepared, but instead the ions were generated in solution from the 2+ species by oxidation. The electrochemical behavior and results of investigating decomposition reactions of the product species shows that the oxidations, which are rapid, take place without complication. The same extinction coefficients were observed in-