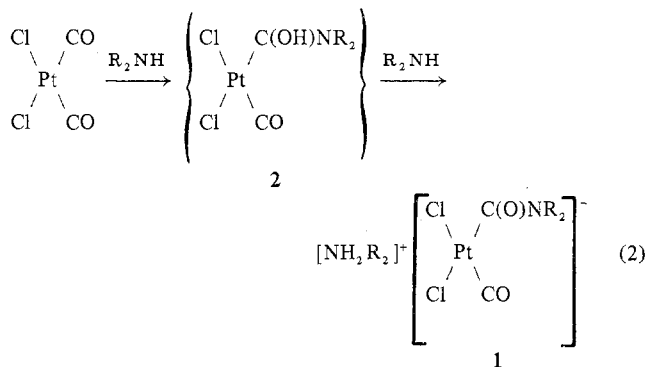

Figure 2. Diagrammatic projection of the structure along [001] showing crystal packing.

The chemical properties of the compound reported in this paper are well in agreement with its molecular structure. In particular it is to be noted that, while the carbamoyl derivative is little soluble in hydrocarbon solvents, it is readily soluble in dichloromethane, certainly as a result of the breaking of $\text{NH}\cdots\text{C}1$ and $\text{NH}\cdots\text{O}$ hydrogen bonds.

It is believed that the formation of **1** may arise from a direct nucleophilic attack of the amine on coordinated carbon monoxide. This may lead to the formation of an intermediate carbene-type²⁹ of complex (**2**), followed by deprotonation by the second molecule of amine and precipitation of the salt-like carbamoyl derivative:



Acknowledgment. The authors thank the National Research Council (CNR, Rome) for support, the Consorzio per la Gestione del Centro di Calcolo Elettronico Interuniversitario dell'Italia Nord-Orientale, Casalecchio, Bologna, for computing facilities, and Chimet S.P.A., Badia al Pino, Arezzo, for platinum chlorides.

Registry No. **1**, 69069-34-7; *cis*-PtCl₂(CO)₂, 15020-32-3; NH-*i*-Pr₂, 108-18-9.

Supplementary Material Available: A listing of observed and calculated structure factors (15 pages). Ordering information is given on any current masthead page.

References and Notes

- (1) University of Pisa.
- (2) University of Parma.
- (3) R. J. Angelici, *Acc. Chem. Res.*, **5**, 335 (1972).
- (4) D. Belli Dell'Amico, F. Calderazzo, and G. Dell'Amico, *Gazz. Chim. Ital.*, **107**, 101 (1977).
- (5) C. R. Green and R. J. Angelici, *Inorg. Chem.*, **11**, 2095 (1972).
- (6) W. Hoppe, *Acta Crystallogr., Sect. A*, **25**, 67 (1969).
- (7) D. T. Cromer and J. B. Mann, *Acta Crystallogr., Sect. A*, **24**, 321 (1968).
- (8) "International Tables for X-Ray Crystallography", Vol. IV, Kynoch Press, Birmingham, England, 1974, pp 149-150.
- (9) G. M. Sheldrick, "SHELX 76. A Program for Crystal Structure Determination", University of Cambridge, Cambridge, England, 1976.
- (10) C. Valentini, Doctoral Thesis, University of Pisa, June 1975.
- (11) L. Manojlović-Muir, K. W. Muir, and R. Walker, *J. Organomet. Chem.*, **66**, C21 (1974).

- (12) H. C. Clark, P. W. R. Corfield, K. R. Dixon, and J. A. Ibers, *J. Am. Chem. Soc.*, **89**, 3360 (1967).
- (13) J. S. Field and P. J. Wheatley, *J. Chem. Soc., Dalton Trans.*, 702 (1974).
- (14) Results by R. S. Hamilton and E. R. Corey; quoted from ref 12.
- (15) M. Orchin and P. J. Schmidt, *Coord. Chem. Rev.*, **3**, 345 (1968).
- (16) P. E. Rush and J. D. Oliver, *J. Chem. Soc., Chem. Commun.*, 996 (1974).
- (17) L. Manojlović-Muir, K. W. Muir, and T. Solomon, *J. Organomet. Chem.*, **142**, 265 (1977).
- (18) D. R. Russell, P. A. Tucker, and S. Wilson, *J. Organomet. Chem.*, **104**, 387 (1976).
- (19) D. M. Chipman and R. A. Jacobson, *Inorg. Chim. Acta*, **1**, 393 (1967).
- (20) G. L. Breneman, D. M. Chipman, C. J. Galles, and R. A. Jacobson, *Inorg. Chim. Acta*, **3**, 447 (1969).
- (21) L. Ricard, J. Estienne, and R. Weiss, *Inorg. Chem.*, **12**, 2182 (1973).
- (22) W. P. Bosman and A. W. Gal, *Cryst. Struct. Commun.*, **4**, 465 (1975).
- (23) W. P. Bosman and A. W. Gal, *Cryst. Struct. Commun.*, **5**, 703 (1976).
- (24) W. K. Dean, J. B. Wetherington, and J. W. Moncrief, *Inorg. Chem.*, **15**, 1566 (1976).
- (25) W. K. Dean, R. S. Charles, and D. G. van Derveer, *Inorg. Chem.*, **16**, 3328 (1977).
- (26) W. K. Dean and D. G. van Derveer, *J. Organomet. Chem.*, **144**, 65 (1978).
- (27) F. Calderazzo, *Angew. Chem.*, **89**, 305 (1977).
- (28) A. De Renzi, B. Di Blasio, G. Paiaro, A. Panunzi, and C. Pedone, *Gazz. Chim. Ital.*, **106**, 765 (1976).
- (29) M. L. H. Green, L. C. Mitchard, and M. G. Swanwick, *J. Chem. Soc. A*, 794 (1971).

Contribution from the Department of Chemistry,
Stanford University, Stanford, California 94305

Pentaammineruthenium Dimethyl Chalcogenide Complexes

Cy A. Stein and Henry Taube*

Received September 22, 1978

The synthesis of $[(\text{NH}_3)_5\text{RuS}(\text{CH}_3)_2]^{2+}$ (and of closely related complexes) has been reported,¹ as well as some of its properties, but the corresponding ruthenium(III) complex has been less completely characterized. We report here a continuation of studies on the pentaammineruthenium(II) and -(III) complexes of $(\text{CH}_3)_2\text{S}$ and the synthesis and characterization of the species with $(\text{CH}_3)_2\text{Se}$ and $(\text{CH}_3)_2\text{Te}$ as ligands.

Experimental Section

The general preparative procedures have been described elsewhere.¹ In fact, the synthesis of the pentaammineruthenium(II) complexes of $(\text{CH}_3)_2\text{S}$ and $(\text{CH}_3)_2\text{Se}$ in solution followed the method outlined there for the former ligand. Solid NH_4PF_6 was used as precipitant and the product, in each case yellow, was obtained in 60% yield. The method was not successful for $(\text{CH}_3)_2\text{Te}$ owing to decomposition of the ligand and to labilization by it of coordinated NH_3 . A pure compound was prepared in 85% yield by allowing a fivefold excess of $(\text{CH}_3)_2\text{Te}$ to react for 30 min with 100 mg of freshly prepared $[(\text{NH}_3)_5\text{Ru}(\text{OH})_2](\text{PF}_6)_2$ in 7 mL of deaerated acetone. On addition the mixture to 40 mL of peroxide-free ether, a yellow solid resulted. This was filtered and washed with ether and dried in vacuo. Anal. Calcd for $\text{C}_2\text{H}_{21}\text{N}_5\text{RuSe}(\text{PF}_6)_2$: C, 4.10; H, 3.62; N, 11.97; Se, 13.49; Ru, 17.28; F, 38.96. Found: C, 3.90; H, 3.42; N, 11.96; Se, 13.1; Ru, 17.6; F, 39.5. Calcd for $\text{C}_2\text{H}_{21}\text{N}_5\text{RuTe}(\text{PF}_6)_2$: C, 3.79; H, 3.34; N, 11.05; Ru, 15.95; F, 35.97. Found: C, 4.15; H, 3.41; N, 10.61; Ru, 15.9; F, 35.5.

Analyses were not performed on the dimethyl sulfide complex, but the identity of the product was confirmed by comparing the spectrum with that reported earlier.¹ The agreement was excellent (within 2% of the value of ϵ at the maximum).

Solids containing the complexes with ruthenium in the 3+ oxidation state were not prepared, but instead the ions were generated in solution from the 2+ species by oxidation. The electrochemical behavior and results of investigating decomposition reactions of the product species shows that the oxidations, which are rapid, take place without complication. The same extinction coefficients were observed in-

Table I. UV-Visible Spectra for the Pentaammineruthenium(II) Complexes of Dimethyl Chalcogenides^a

complex	λ_{\max} , nm (ϵ)
$[(\text{NH}_3)_5\text{RuS}(\text{CH}_3)_2]^{2+}$	358 (64)
	258 (2.14×10^3) ^b
	235 (2.05×10^3) ^b
$[(\text{NH}_3)_5\text{RuSe}(\text{CH}_3)_2]^{2+}$	378 (90)
	275 (1.95×10^3)
	235 sh ($\sim 2.1 \times 10^3$)
$[(\text{NH}_3)_5\text{RuTe}(\text{CH}_3)_2]^{2+}$	318 (1.41×10^3)
	243 (4.75×10^3)

^a In 0.1 M HCl at 25 °C. ^b Reference 1.

dependent of the choice of oxidizing agent—anode, Ce(IV) or H₂O₂—and moreover, an oxidized solution on being reduced by Zn/Hg yielded quantitatively the spectrum expected for the 2+ species. Oxygen can also be used as an oxidizing agent but the reaction is quite slow.

Results

Data on the spectra of the 2+ species are summarized in Table I. The three 2+ species showed reversible electrochemical behavior on a platinum button electrode in cyclic voltammetry over the range of scan speeds covered, 100–1000 mV s⁻¹. The values of E_f (vs. NHE and taken as the mean of E at the oxidation and reduction maxima) in 0.1 M HCl at 25 °C were observed as 0.50, 0.45, and 0.44 V.

It is important for the study of the complexes in solution to know just how stable they are with respect to aquation and accordingly some measurements were made of the rates at which the ruthenium(II) species deteriorate in aqueous solution. These were not highly refined but they meet the intended purpose of indicating the time scale on which decomposition is significant.

The experiments were done in an oxygen-free medium, 0.20 M in HCl and 0.10 M in 4-cyanopyridine (4-cpy). In this environment, 4-cpy is virtually completely protonated (pK_a for 4-cpyH⁺ is 2.72),² so that the prevailing concentration of H⁺ is 0.10 M. The cyanopyridine serves to scavenge any aquo species formed, and, from the absorption spectrum of the product formed, it is possible to learn whether aquation involves loss of ammonia or of the chalcogenide containing ligand. The work of Kuehn and Taube¹ showed that any aquo species is rapidly scavenged by [4-cpyH⁺] at the 0.10 M concentration level—i.e., the rate of formation of the pyridine-containing product is independent of the concentration of this ligand. This point was not further tested in our work, but the simple kinetic behavior at least for the first few half-lives shows that significant quantities of an aquo intermediate did not accumulate in any of our experiments.

If aquation involved replacement of the ligand, $[(\text{NH}_3)_5\text{Ru}(4\text{-cpyH})]^{3+}$, which shows an absorption maximum at 532 nm, would be formed. The band maximum for the product formed on the aquation of the dimethyl sulfide complex was reported¹ to be at 490 nm, the shift in the energy of the Ru(II)–(4-cpyH) oscillator being produced by the electron-withdrawing effect of (CH₃)₂S. The products formed in our experiments with the other two dimethyl chalcogenide ligands had maxima at 495 nm, thus showing that in those cases also, NH₃ rather than (CH₃)₂X is being replaced. Values of $\ln(A_\infty - A_t)$, where A is the absorbance at the new band maximum, were plotted against time, t . The plots were linear to only 2 half-lives for the complex of (CH₃)₂Se and to about 4 for that of (CH₃)₂Te; as shown by the shift in the band maximum at longer reaction times secondary reactions do occur. For the former complex, A_∞ was arbitrarily taken as the value at 3 half-lives. This approximation can introduce an error of as much as 20% in the absolute value of the specific rate, but this does not vitiate the purpose for which the measurements were undertaken.

Table II. UV-Visible Spectra for the Pentaammineruthenium(III) Complexes of Dimethyl Chalcogenides

complex	λ_{\max} , nm (ϵ)	comments
$[(\text{NH}_3)_5\text{RuS}(\text{CH}_3)_2]^{3+}$	453 (300) ^a	in 0.2 M HCl
	310 sh (~ 800)	in 4.0 M HCl; outer sphere chloride \rightarrow Ru(III) CT band
	285 (930)	in 4.0 M HCl
$[(\text{NH}_3)_5\text{RuSe}(\text{CH}_3)_2]^{3+}$	220 ($\sim 5 \times 10^3$)	in 4.0 M HCl
	487 (150) ^a	in 0.2 M HCl
	303 (750)	in 4.0 M HCl
	235 ($\sim 6 \times 10^3$)	in 4.0 M HCl
$[(\text{NH}_3)_5\text{RuTe}(\text{CH}_3)_2]^{3+}$	600 (60) ^a	in 0.2 M HCl

^a LMCT transition.

The dominant reactions at least for the first few half-lives in the systems studied are

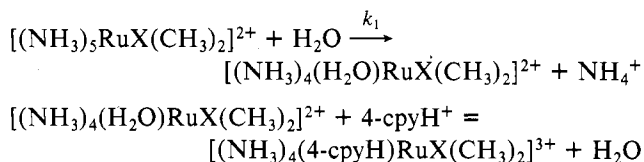

where the second reaction is rapid compared to the first. The values of k_1 (25 °C, [H⁺] = 0.10 M, μ = 0.10) are (4.2 ± 0.3) $\times 10^{-6}$, (1.0 ± 0.2) $\times 10^{-5}$, and (1.2 ± 0.1) $\times 10^{-4}$ s⁻¹ for X = S, Se, and Te, respectively.

It is uncertain whether cis or trans ammonia is lost but a preponderance of evidence indicates that it is the latter. Elder and Trkula² have demonstrated a ground-state trans effect of 0.058 (9) Å in the compound $[(\text{NH}_3)_5\text{RuSSRu}(\text{NH}_3)_5] \cdot \text{Cl}_4 \cdot 2\text{H}_2\text{O}$, and ligands such as P(OC₂H₅)₃³ and SO₃²⁻⁴ are well established as stabilizing trans ammonia coordinated to Ru(II). On Co(III), another πd^6 system, coordinated selenol induces a ground-state trans effect of 0.063 (9) Å, to be compared to 0.041 (10) Å produced by coordinated thiol in the analogous ion.⁵

Our ordering of increasing labilization as (CH₃)₂S < (CH₃)₂Se < (CH₃)₂Te parallels that reported by Chatt et al.⁶ who based their conclusions on N–H stretching frequencies, band intensities, and association quotients for a series of Pt(II) complexes, *trans*-[(CH₃)₂X(am)PtCl₂] (where am = RNH₂ or R₂NH). The enhanced labilization as period number increases can be attributed at least in part to the increase in chalcogenide polarizability in the series.

Oxidation of $[(\text{NH}_3)_5\text{Ru}(\text{S}(\text{CH}_3)_2)]^{2+}$ with Ce(IV), 30% H₂O₂, or O₂ in 0.2 M HCl yielded an orange solution containing the ion $[(\text{NH}_3)_5\text{RuS}(\text{CH}_3)_2]^{3+}$ with the lowest energy band at 453 nm (ϵ 3.0×10^2 M⁻¹ cm⁻¹). This transition is assigned to ligand-to-metal charge transfer (LMCT). Other transitions are observed in the UV, but because these are ligand field in origin or ligand centered, their properties were not extensively investigated and our interest focused on that of lowest energy. Similar transitions are featured by the Se and Te complexes. The data on the spectra of the 3+ species are summarized in Table II.

The low-energy transitions provide a convenient method for measuring the rate of loss of (CH₃)₂X from a Ru(III) center. The experiments on the rate of aquation were done in solutions containing 0.20 M HCl and 0.10 M LiCl. Values of absorbance at 453 nm (S), 487 nm (Se), and 600 nm (Te) were measured daily and the data were displayed in standard semilog plots. For $[(\text{NH}_3)_5\text{RuS}(\text{CH}_3)_2]^{3+}$ a value of A_∞ = 0.1 was assumed because the low rate made it impractical to wait for a limiting value of the absorbance. At the wavelength of the measurements and at the concentrations of $[(\text{NH}_3)_5\text{RuS}(\text{CH}_3)_2]^{3+}$ used in these studies, the final product

$[(\text{NH}_3)_5\text{RuCl}]^{2+}$ has an absorbance of ~ 0.1 . The plots for the $[(\text{NH}_3)_5\text{RuSe}(\text{CH}_3)_2]^{3+}$ complex were fairly linear for 3 half-lives, but accurate data for the $[(\text{NH}_3)_5\text{RuTe}(\text{CH}_3)_2]^{3+}$ complex could not be obtained owing to precipitation of a white material on the walls of the cell (probably decomposition products of $(\text{CH}_3)_2\text{Te}$). However, the measurements sufficed to show that the rate of ligand aquation is approximately the same (within a factor of 2) as that for $[(\text{NH}_3)_5\text{RuSe}(\text{CH}_3)_2]^{3+}$. The results for the two tractable systems are (25 °C, $[\text{HCl}] = 0.20 \text{ M}$, $[\text{LiCl}] = 0.10 \text{ M}$): for the dimethyl sulfide complex, $k = (2.6 \pm 0.1) \times 10^{-7} \text{ s}^{-1}$, based on experiments with $[\text{Ru(III)}]_0 \times 10^3 = 6.5, 3.1, 1.9 \text{ M}$; for the dimethyl selenide complex, $k = (1.59 \pm 0.04) \times 10^{-6} \text{ s}^{-1}$, $[\text{Ru(III)}]_0 \times 10^3 = 3.2, 6.6, 7.5, 10.7 \text{ M}$.

Discussion

The experiments described show that the pentaammine-ruthenium(II) and -(III) complexes of $(\text{CH}_3)_2\text{S}$, $(\text{CH}_3)_2\text{Se}$, and $(\text{CH}_3)_2\text{Te}$ are readily prepared and that they retain their integrity in aqueous solution sufficiently long so that they can be characterized by ordinary methods.

The long reaction half-lives observed for the loss of $(\text{CH}_3)_2\text{X}$ from $(\text{NH}_3)_5\text{Ru}^{\text{III}}$, particularly when $\text{X} = \text{S}$, are remarkable considering that the proton affinity of the dimethyl chalcogenide ligands is low ($\text{p}K_a((\text{CH}_3)_2\text{SH}_2^+) = -5.2$).⁷ However, because there is a vacant site of π symmetry in the t_{2g} set of Ru(III), its interaction with a ligand is different from that of a proton. It is likely that ligand-to-metal charge transfer into this orbital contributes to the inertia of the Ru(III)-X linkage to aquation. This suggestion presupposes that the slow rate is paralleled by a greater affinity of $(\text{CH}_3)_2\text{S}$ for Ru(III) than for a proton, and this does seem to be the case.¹ Ground-state charge transfer from ligand to Ru(III) also helps explain the greater acidity of $(\text{NH}_3)_5\text{RuOH}_2^{3+}$ ($\text{p}K_a = 4.2$)⁸ compared to $(\text{NH}_3)_5\text{CoOH}_2^{3+}$ ($\text{p}K_a = 6.6$).⁹ Because ground-state ligand-to-metal charge transfer decreases with increasing period number (see below), the contribution to substitution inertia from this source decreases, thus partially explaining the greater lability of $(\text{CH}_3)_2\text{Se}$ relative to $(\text{CH}_3)_2\text{S}$.

The decrease in ϵ of the LMCT band from S to Se to Te, 453 (300), 487 (150), 600 (60), respectively, is striking. While the decrease in energy at the maxima can easily be understood in terms of the increasing ease of oxidation of the ligand, the decrease in ϵ occurs in spite of the increase in diffusivity of the valence orbitals with period number. The observations can be understood in terms of the decrease in s-p hybridization as period number increases,¹⁰ the lone pair becoming increasingly "s" in character. One manifestation of this decrease is the lowering of the H-X-H bond angle from 104.5° ($\text{X} = \text{O}$)¹¹ to 92.3° ($\text{X} = \text{S}$),¹² 91° ($\text{X} = \text{Se}$), and 89.5° ($\text{X} = \text{Te}$).¹³ In cases as extreme as those of thallium and lead, where Tl(III) and Pb(IV) are very strong oxidants, the orbitals of "s" character are drawn in so far to the kernel that they are referred to as an "inert pair"¹⁴ in the 1+ and 2+ states, respectively. Overlap of an orbital that is increasingly "s" in character with d orbitals of the metal is expected to become increasingly poor, and this trend is compounded by the increase in Ru-X bond length⁵ as the period number increases.

The spectrophotometric data in Table I remain to be considered. The bands at lowest energy can be assigned as arising from ligand field transitions. Absorptions in this wavelength region have been reported in other cases: Ru- $(\text{NH}_3)_6^{2+}$ (shoulder at 390–400 nm, $\epsilon = 40 \pm 3$);¹⁵ Ru- $(\text{NH}_3)_5\text{H}_2\text{O}^{2+}$ (420 nm, $\epsilon \sim 10^2$; 416 nm, $\epsilon = 40 \pm 1$).¹⁵ For $(\text{CH}_3)_2\text{Te}$ the ligand field absorption is covered by the very strong band which has a maximum at 318 nm. The absorptions at higher energy presumably arise from metal-to-ligand charge transfer. This assignment raises the question of the identity of the acceptor orbitals on the chalcogen atom.

Apart from the absorption characteristics referred to, chemical evidence supports the conclusion that the interaction between Ru(II) and $(\text{CH}_3)_2\text{S}$, for example, involves more than simple σ donation by the ligand to the metal ion. The most significant item of evidence is that when an ammonia in the hexaammine is replaced by $(\text{CH}_3)_2\text{S}$, the Ru(II) state is stabilized relative to Ru(III) by ca. 0.5 V. It cannot be argued that the quality of Ru(II) as an electrophile is like that of Hg^{2+} , which is known to have a high affinity for reduced sulfur. The affinity of Ru(II) for OH^- is very much less than that of Hg^{2+} ($\text{p}K_a$ for $(\text{NH}_3)_5\text{RuOH}_2^{2+}$ is ~ 13 while that of $\text{Hg}^{2+}(\text{aq})$ is ~ 2.5)¹⁷ and the affinity of Ru(II) for I^- is also relatively low.¹⁸ There is, however, no requirement that 3d orbitals for S are used in back-bonding. (Good arguments have been advanced¹⁹ by others for assigning a minor role to the d orbitals of sulfur when it is in the reduced state.) The ligand orbitals used as repositories for back-bonding electron density and in MLCT may in fact be σ^* .

The change in energy of the MLCT bands is not inconsistent with the idea that the acceptor orbitals on the chalcogen are derived from valence s and p orbitals. The electronegativities of S and C are similar, and when a bond between them forms, the perturbation leading to splitting into σ and σ^* levels is very great. Though the valence p orbital for Se is closer to that of Ru(II), a factor which alone would raise the σ^* for Se above S, the perturbation resulting from C-Se interaction is less, and thus the σ^* level for $(\text{CH}_3)_2\text{Se}$ may be below that of $(\text{CH}_3)_2\text{S}$, consonant with the change in energy of the MLCT band. A similar argument is applicable to $(\text{CH}_3)_2\text{Te}$.

Acknowledgment. The many discussions of this work with Dr. R. Oakley were very illuminating and are greatly appreciated. We also take pleasure in acknowledging support of this research by NIH Grant No. GM13638-13.

Registry No. $[(\text{NH}_3)_5\text{RuS}(\text{CH}_3)_2]^{2+}$, 58619-10-6; $[(\text{NH}_3)_5\text{RuSe}(\text{CH}_3)_2]^{2+}$, 69204-61-1; $[(\text{NH}_3)_5\text{RuTe}(\text{CH}_3)_2]^{2+}$, 69204-59-7; $[(\text{NH}_3)_5\text{RuS}(\text{CH}_3)_2]^{3+}$, 69204-65-5; $[(\text{NH}_3)_5\text{RuSe}(\text{CH}_3)_2]^{3+}$, 69204-64-4; $[(\text{NH}_3)_5\text{RuTe}(\text{CH}_3)_2]^{3+}$, 69204-63-3; $[(\text{NH}_3)_5\text{Ru}(\text{OH}_2)](\text{PF}_6)_2$, 34843-18-0; $[(\text{NH}_3)_5\text{RuSe}(\text{CH}_3)_2](\text{PF}_6)_2$, 69204-62-2; $[(\text{NH}_3)_5\text{RuTe}(\text{CH}_3)_2](\text{PF}_6)_2$, 69204-60-0.

References and Notes

- (1) C. G. Kuehn and H. Taube, *J. Am. Chem. Soc.*, **98**, 689 (1976).
- (2) R. C. Elder and M. Trkula, *Inorg. Chem.*, **16**, 1048, (1977).
- (3) D. Franco and H. Taube, *Inorg. Chem.*, **17**, 571 (1978).
- (4) S. S. Isied and H. Taube, *Inorg. Chem.*, **13**, 1545 (1974).
- (5) C. A. Stein, P. E. Ellis, R. C. Elder, and E. Deutsch, *Inorg. Chem.*, **15**, 1618 (1976).
- (6) J. Chatt, L. A. Duncanson, and L. M. Venanzi, *J. Chem. Soc.*, 4461 (1955).
- (7) A. J. Gordon and R. A. Ford, "The Chemist's Companion", Wiley, New York, 1972, p 60; citing G. Kortum, W. Vogel, and K. Andrussov, "Dissociation Constants of Organic Acids in Aqueous Solution", Plenum Press, New York, 1961.
- (8) J. A. Broomhead, F. Basolo, and R. G. Pearson, *Inorg. Chem.*, **3**, 826 (1964).
- (9) E. Chaffee, T. P. Dasgupta, and G. M. Harris, *J. Am. Chem. Soc.*, **95**, 4169 (1973).
- (10) R. Steudel, *Angew. Chem., Int. Ed. Engl.*, **14**, 655 (1975).
- (11) F. A. Cotton and G. Wilkinson, "Advanced Inorganic Chemistry", Wiley-Interscience, New York, 1972, p 407.
- (12) A. Burg in "Organic Sulfur Compounds", N. Kharash, Ed., New York, 1961, p 30.
- (13) K. W. Gagnall, "The Chemistry of Selenium, Tellurium and Polonium", Elsevier, Amsterdam, 1966, p 43.
- (14) Reference 11, p 260.
- (15) H. Krentzien, Ph.D. Thesis, Stanford University, July 1976.
- (16) J. F. Endicott and H. Taube, *J. Am. Chem. Soc.*, **84**, 4984 (1962).
- (17) A. B. Garrett and W. N. Howell, *J. Am. Chem. Soc.*, **61**, 1730 (1939).
- (18) The quotient governing association of Cl^- with $[(\text{NH}_3)_5\text{RuOH}_2]^{2+}$ is 1.6 (H. S. Lim, D. J. Barclay, and F. C. Anson, *Inorg. Chem.*, **11**, 1460 (1972)); that for I^- is likely different by less than a factor of 10. K_{assoc} for $\text{Hg}^{2+} + \text{I}^-$ is $\sim 10^{13}$. (L. G. Sillen, *Acta Chem. Scand.*, **3**, 39 (1949)).
- (19) (a) A. Streitwieser, Jr., and S. P. Ewing, *J. Am. Chem. Soc.*, **97**, 190 (1975). (b) A. Streitwieser, Jr., and J. G. Williams, *ibid.*, **97**, 191 (1975). (c) N. H. Epitotis, R. L. Yates, F. Bernardi, and S. Wolfe, *ibid.*, **98**, 5435 (1975). (d) S. Wolfe, A. Rank, and I. G. Csizmodia, *ibid.*, **89**, 5710 (1967).