

Contribution from the Department of Chemistry, The University of Utah, Salt Lake City, Utah 84112

Bis(trimethylphosphine) Adduct of Tetraborane(8)GOJI KODAMA* and MITSUAKI KAMEDA¹

Received March 16, 1979

A new member of B_4 hypophosphite class borane compounds, $B_4H_8 \cdot 2P(CH_3)_3$, was prepared by the reaction of B_5H_{11} with excess $P(CH_3)_3$. The new compound is a sublimable solid at room temperature and reacts readily with HCl to give $(CH_3)_3P \cdot B_3H_7$ and $(CH_3)_3P \cdot BH_2Cl$. The B_4H_8 adduct is also produced in the reaction of $B_5H_9 \cdot 2P(CH_3)_3$ with HCl in tetrahydrofuran at $-80^\circ C$. The compound is compared with a previously reported hypophosphite compound $B_4H_8 \cdot TMED$ ($TMED = N,N,N',N'$ -tetramethylethylenediamine), and a structural discussion is given on the basis of the 1H , ^{11}B , and ^{31}P NMR data of the compound. The mono(trimethylphosphine) adduct of B_4H_8 is also reported.

Introduction

Recently the reaction of pentaborane(11), B_5H_{11} , with trimethylamine to give trimethylamine-tetraborane(8), $B_4H_8 \cdot N(CH_3)_3$, and trimethylamine-borane(3) was established by isolating the products.² The tetraborane adduct was found to be stable toward bases. This finding was rather surprising because it had been thought that the B_4H_8 unit would be unstable toward strong bases³ and, therefore, the isolation of the trimethylamine adduct would be unsuccessful. It was then of interest to us to investigate the reaction of B_5H_{11} with trimethylphosphine which is a stronger base toward borane(3) than $(CH_3)_3N$.⁴ The reaction yielded a stable bis(trimethylphosphine) adduct of tetraborane(8), $B_4H_8 \cdot 2P(CH_3)_3$, and trimethylphosphine-tetraborane(8), $B_4H_8 \cdot P(CH_3)_3$. This bis(trimethylphosphine) adduct is a new addition to the B_4 hypophosphite class boron hydride compounds, examples of which have so far been scarce. The formation and the characterization of these trimethylphosphine adducts of tetraborane(8) are reported in this paper.

Results

A. Formation and Properties of $B_4H_8 \cdot 2P(CH_3)_3$. The reaction of B_5H_{11} with excess $P(CH_3)_3$ (3–5 mol/mol of B_5H_{11}) in dichloromethane proceeds according to

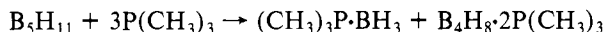

The bis(trimethylphosphine) adduct of tetraborane(8) is a colorless solid and can be separated from $(CH_3)_3P \cdot BH_3$ by fractional sublimation at room temperature. The compound is stable enough for most of its characterization studies in vacuo but decomposes slowly upon prolonged standing at room temperature.

When B_5H_{11} is treated with a deficient amount of $P(CH_3)_3$, e.g., 1:2.6 molar ratio, a mixture of $B_4H_8 \cdot 2P(CH_3)_3$ and $B_4H_8 \cdot P(CH_3)_3$ is formed. When the reactants are mixed in a 1:2 molar ratio, the product is a complex mixture of boron hydride compounds containing $B_4H_8 \cdot P(CH_3)_3$ as the major component.

The bis(trimethylphosphine) adduct is also produced in the reaction of $B_5H_9 \cdot 2P(CH_3)_3$ with anhydrous hydrogen chloride at $-80^\circ C$ in tetrahydrofuran (THF)

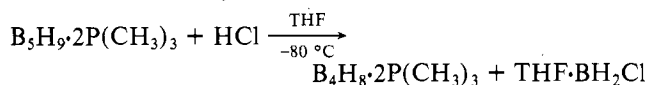

At room temperature, the products transform to $B_4H_8 \cdot P(CH_3)_3$ and $(CH_3)_3P \cdot BH_2Cl$.

The compound $B_4H_8 \cdot 2P(CH_3)_3$ reacts readily with anhydrous hydrogen chloride at $-80^\circ C$ to give $(CH_3)_3P \cdot B_3H_7$ and $(CH_3)_3P \cdot BH_2Cl$:

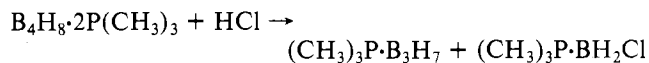

The compound, however, is stable toward trimethylphosphine; it remains unchanged for 1 h in a CH_2Cl_2 solution in the presence of excess $P(CH_3)_3$ at room temperature.

B. Mass and NMR Spectra of $B_4H_8 \cdot 2P(CH_3)_3$. **Mass Spectrum.** The highest intensity peak in the high-mass cutoff region appears at m/e 202 which is 2 units less than that expected for the $B_4H_8 \cdot 2P(CH_3)_3^+$ ion on the basis of the natural abundance of boron and carbon isotopes. Furthermore, the mass distribution observed for the region is not that expected for a single " B_4C_6 " species. The distribution, however, agrees well if the peaks are attributed to a mixture of $B_4H_8 \cdot 2P(CH_3)_3^+$, $B_4H_6 \cdot 2P(CH_3)_3^+$, $B_4H_4 \cdot 2P(CH_3)_3^+$, and $B_4H_2 \cdot 2P(CH_3)_3^+$ ions. A pattern similar to this was observed for the trimethylamine adduct of tetraborane(8),² and facile, successive loss of pairs of hydrogen atoms from boron hydride species has been commonly observed.⁵

NMR Spectra. The ^{11}B and 1H NMR spectra of $B_4H_8 \cdot 2P(CH_3)_3$ are shown in Figures 1 and 2, respectively. At $20^\circ C$ the ^{11}B spectrum contains two broad signals at -17.1 and 41.7 ppm [$BF_3 \cdot O(C_2H_5)_2$ reference, downfield positive] in a 1:1 intensity ratio. When the 1H spins are decoupled, the low-field peak sharpens considerably more than the high-field peak (Figure 1b). This suggests that the phosphine ligands are attached to the boron atoms which are responsible for the high-field signal. In the 1H spectrum at $25^\circ C$ a typical $X_nAA'X'_n$ pattern⁶ is seen at δ 1.18 for the methyl protons. The signal of the hydrogen atoms (H_B) that are bound to boron atoms is only discernible as a very broad slight hump centered at δ 0.63. When the ^{11}B spins are decoupled, the hump changes to a broad triplet ($J_{HP} = 2.6$ Hz) at δ 0.63 (Figure 2b).

When the sample is cooled, the ^{11}B and 1H spectra both undergo significant changes. As shown in Figure 1c–f, the high-field peak in the ^{11}B spectra broadens and splits into two peaks of equal intensities, the peak positions being at -37.4 and -47.0 ppm at $-50^\circ C$. Further lowering of the temperature results in progressive broadening of all three peaks. The splitting of the high-field peak is not due to the ^{11}B – ^{31}P spin coupling, for the separation of the two peaks (ca. 310 Hz) is much too large compared with the B–P coupling constants (60–120 Hz) in the known trimethylphosphine adducts of boranes⁷ and irradiation of the sample with the ^{31}P resonance frequency does not convert them to a single peak.

The H_B signal in the ^{11}B -spin-decoupled 1H spectrum broadens upon cooling the sample, the triplet feature being lost first. Then at $-50^\circ C$ a hump begins to develop at the high-field side of the peak. At $-60^\circ C$ or below the presence of two signals at δ 0.31 and 0.59 is obvious (Figure 2c–f). The intensity ratio is about 1:3. Each peak in the $X_nAA'X'_n$ pattern of the methyl proton (H_C) signal broadens, but the pattern remains unchanged even at $-95^\circ C$. The H_C signal changes to a singlet when the ^{31}P spins are decoupled. It is noted that the methyl proton signal at $-82^\circ C$ observed on a 300-MHz instrument (Varian SC300) has a complex feature and deviates from the simple $X_nAA'X'_n$ pattern.

The ^{31}P NMR spectra (1H -spin decoupled) of $B_4H_8 \cdot 2P(CH_3)_3$ at various temperatures are shown in Figure 3. The trapezoidal shape in the $0^\circ C$ spectrum indicates the presence

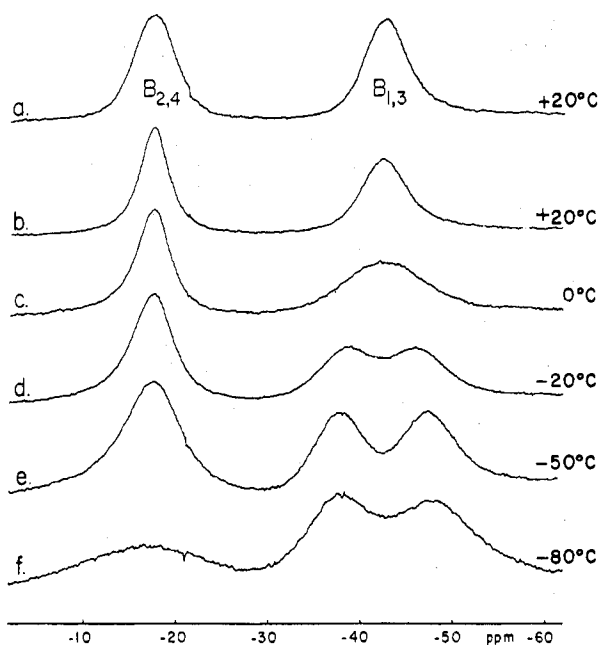

Figure 1. ^{11}B NMR spectra of $\text{B}_4\text{H}_8 \cdot 2\text{P}(\text{CH}_3)_3$ in CD_2Cl_2 : (a) normal spectrum; (b-f) proton-spin-decoupled spectra.

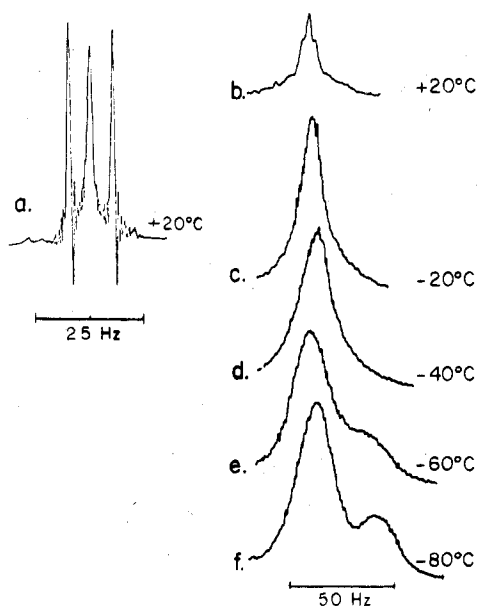

Figure 2. ^1H NMR spectra of $\text{B}_4\text{H}_8 \cdot 2\text{P}(\text{CH}_3)_3$ in CD_2Cl_2 , ^{11}B -spin decoupled: (a) methyl proton signal; (b-f) borane proton signals.

of the $\text{P}-^{11}\text{B}$ spin coupling. The signal narrows as the temperature is lowered, and at about -95°C the line width is about 30 Hz. Such a thermal spin-decoupling effect has also been observed for other boron hydride compounds.⁸ Structural discussion on the bis(trimethylphosphine) adduct based on the NMR data described above is given in a later part of this paper.

C. Trimethylphosphine-Tetraborane(8), $\text{B}_4\text{H}_8 \cdot \text{P}(\text{CH}_3)_3$. In section A, the formation of $\text{B}_4\text{H}_8 \cdot \text{P}(\text{CH}_3)_3$ was mentioned. This compound is also formed in the reaction between $\text{B}_4\text{H}_8 \cdot 2\text{P}(\text{CH}_3)_3$ and $\text{BH}_2\text{Cl} \cdot \text{THF}$ and in the room-temperature decomposition products of $\text{B}_4\text{H}_8 \cdot 2\text{P}(\text{CH}_3)_3$. The compound is slightly more volatile than $\text{B}_4\text{H}_8 \cdot 2\text{P}(\text{CH}_3)_3$ and, therefore, can be pumped out at 10°C from a mixture of the two compounds. Although it has not been isolated as a pure compound and $\text{B}_4\text{H}_8 \cdot 2\text{P}(\text{CH}_3)_3$ and $(\text{CH}_3)_3\text{P} \cdot \text{BH}_3$ have always been the impurities, the compound could be identified by the ^{11}B NMR spectrum of the sample because of its spectral pattern that is

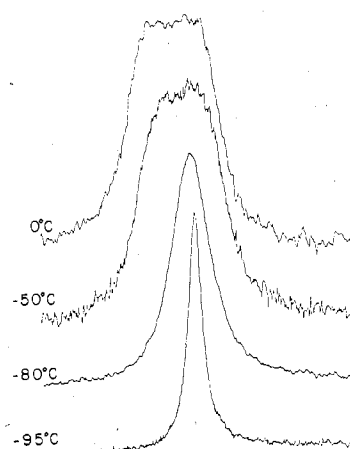

Figure 3. ^{31}P NMR spectra of $\text{B}_4\text{H}_8 \cdot 2\text{P}(\text{CH}_3)_3$ in CD_2Cl_2 , proton-spin decoupled [chemical shift: 1.8 ppm at 0°C and 0.8 ppm at -95°C ($85\% \text{H}_3\text{PO}_4$ reference)].

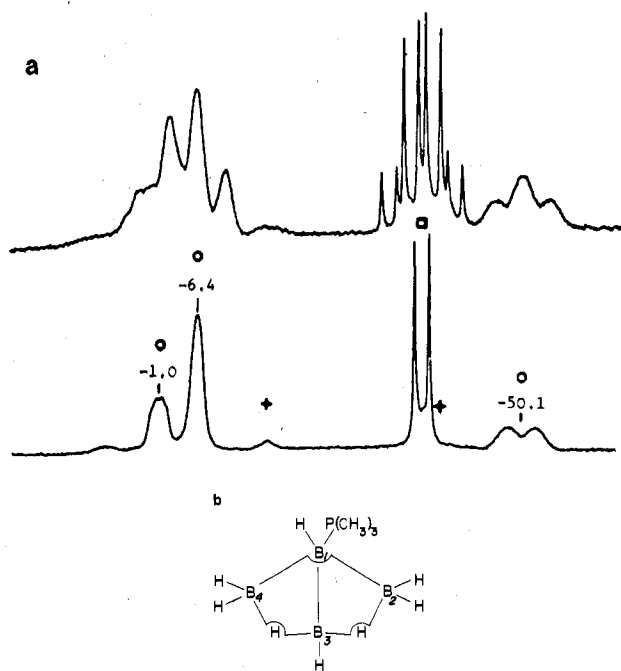

Figure 4. (a) ^{11}B NMR spectra of a sample containing $\text{B}_4\text{H}_8 \cdot \text{P}(\text{CH}_3)_3$ (solvent CH_2Cl_2 ; temperature ambient): upper spectrum, normal; lower spectrum, ^1H -spin decoupled; O, $\text{B}_4\text{H}_8 \cdot \text{P}(\text{CH}_3)_3$; □, $(\text{CH}_3)_3\text{P} \cdot \text{BH}_3$; +, $\text{B}_4\text{H}_8 \cdot 2\text{P}(\text{CH}_3)_3$. (b) Structure of $\text{B}_4\text{H}_8 \cdot \text{P}(\text{CH}_3)_3$.

characteristic of amine and phosphine adducts of tetraborane(8)^{2,9} (Figure 4a). At $+25^\circ\text{C}$ the signals appear at -50.1 (B_1 , triplet, $J_{\text{BP}} \approx J_{\text{BH}} = 114$ Hz), -6.4 ($\text{B}_{2,4}$, triplet, $J_{\text{BH}} = 121$ Hz), and -1.0 ppm (B_3 , doublet, $J_{\text{BH}} = 130$ Hz). When the ^1H spins are decoupled, the signal at -50.1 ppm becomes a doublet ($J_{\text{BP}} = 118$ Hz) and the other two signals sharpen to singlets. The data are consistent with the structure given in Figure 4b, which is drawn after the structure of $(\text{CH}_3)_2\text{NPF}_2 \cdot \text{B}_4\text{H}_8$.¹⁰ It is noted that the signal peak at -1.0 ppm has a discernible hyperfine structure similar to that observed for the corresponding signal in the spectrum of $(\text{C}-\text{H}_3)_3\text{N} \cdot \text{B}_4\text{H}_8$.² This may be attributed to the $^{11}\text{B}_3-^{11}\text{B}_1$ spin coupling, the value for $J_{\text{B}_3-\text{B}_1}$ being about 20 Hz.

Discussion

A. Reaction of Pentaborane(11) with Trimethylphosphine. Similarities among the reactions of B_2H_6 , B_4H_{10} , and B_5H_{11} with Lewis bases are known. These boranes undergo symmetrical or unsymmetrical cleavages upon reactions with Lewis bases.^{3b} The nature of the bases determines the mode of the cleavage. Thus, ammonia is known to be the representative

base which cleaves these boranes unsymmetrically to give $H_2B(NH_3)_2^+$ salts of BH_4^- ,¹¹ $B_3H_8^-$,¹² and $B_4H_9^-$,¹³ ions, respectively. Trimethylamine, on the other hand, is known to produce symmetrical cleavage products such as $(CH_3)_3N \cdot BH_3$,¹⁴ $(CH_3)_3N \cdot B_3H_7$,¹⁵ and $(CH_3)_3N \cdot B_4H_8$.²

Trimethylphosphine usually follows the pattern of the trimethylamine reactions. Thus the compounds $(CH_3)_3P \cdot BH_3$ and $(CH_3)_3P \cdot B_3H_7$ were prepared long ago by the symmetrical cleavage reaction of B_4H_{10} with the phosphine.¹⁶ The recent successful isolation of $(CH_3)_3N \cdot B_4H_8$ and the finding of its unexpected stability toward Lewis bases² suggested that the reaction of B_5H_{11} with trimethylphosphine would also give an isolable B_4H_8 adduct of $P(CH_3)_3$. Indeed, the treatment of B_5H_{11} with excess $P(CH_3)_3$ resulted in the symmetrical cleavage of the borane. The reaction, however, is different from the trimethylamine reaction in that $B_4H_8 \cdot P(CH_3)_3$, which is initially produced, reacts further with $P(CH_3)_3$ to form a stable bis(trimethylphosphine) adduct $B_4H_8 \cdot 2P(CH_3)_3$. Because of this second base addition to $B_4H_8 \cdot P(CH_3)_3$, if the initial mixing ratio between B_5H_{11} and $P(CH_3)_3$ is 1:2, unchanged B_5H_{11} remains in the system and reacts with the B_4H_8 adduct that has been produced in the reaction, in a manner similar to that observed for the reaction of B_5H_{11} with $N(CH_3)_3$,² giving a complex mixture of boron hydride compounds. Use of a large excess of $P(CH_3)_3$ results in the exclusive formation of the stable bis(phosphine) adduct. The preparation of pure $B_4H_8 \cdot P(CH_3)_3$ is thus made difficult. In the trimethylamine reaction, the corresponding bis(trimethylamine) adduct is formed likewise if excess amine is used, but the bis(trimethylamine) adduct is unstable at room temperature with respect to its thermal dissociation, $B_4H_8 \cdot 2N(CH_3)_3 \rightleftharpoons B_4H_8 \cdot N(CH_3)_3 + N(CH_3)_3$.² The mono(trimethylamine) adduct, therefore, can readily be isolated.

The formation of $B_4H_8 \cdot 2P(CH_3)_3$ from $B_5H_9 \cdot 2P(CH_3)_3$ by the HCl reaction represents a case of transformation of a B_5 hypoph compound to a B_4 hypoph compound and formally compares with the formation of $B_4H_8 \cdot TMED$ ($TMED = N,N,N',N'$ -tetramethylethylenediamine) by the alcoholysis of $B_5H_9 \cdot TMED$.¹⁷ Structures of $B_5H_9 \cdot 2P(CH_3)_3$ ¹⁸ and $B_5H_9 \cdot TMED$ ¹⁹ have been reported and are different in the manner of the base addition. A similar difference may, therefore, be expected between the two B_4H_8 adducts. This point becomes useful for the structural discussion of these B_4H_8 adducts. (See section C of Discussion.)

B. Chemical Properties of the Phosphine Adducts of B_4H_8 . The stability of $B_4H_8 \cdot N(CH_3)_3$ is enhanced in basic media, but the compound is sensitive to acids.² Apparently the behavior of $B_4H_8 \cdot P(CH_3)_3$ parallels that of $B_4H_8 \cdot N(CH_3)_3$. The stability of the phosphine adducts toward excess $P(CH_3)_3$ and the reaction of the compound with HCl were mentioned earlier in this paper. The HCl reaction of $B_4H_8 \cdot 2P(CH_3)_3$ is similar to that of $B_4H_8 \cdot 2N(CH_3)_3$ (at low temperatures)²⁰ and to that of $B_4H_8 \cdot N(CH_3)_3$ in basic media, in which $(CH_3)_3N \cdot B_3H_7$ and the BH_2Cl adduct are obtained.²

A simple extrapolation of the degradation of $B_5H_9 \cdot 2P(CH_3)_3$ to $B_4H_8 \cdot 2P(CH_3)_3$, described in part A of the Results, would be the formation of $B_3H_7 \cdot 2P(CH_3)_3$ from $B_4H_8 \cdot 2P(CH_3)_3$ by its reaction with HCl. However, no evidence for the formation of $B_3H_7 \cdot 2P(CH_3)_3$ could be found in the ¹¹B NMR spectra of the reaction mixture. Treatment of $(CH_3)_3P \cdot B_3H_7$ with $P(CH_3)_3$ gives $B_2H_4 \cdot 2P(CH_3)_3$ and $(CH_3)_3P \cdot BH_3$, and again no indication of the $B_3H_7 \cdot 2P(CH_3)_3$ was ever observed in the ¹¹B NMR spectra of the reaction mixture.

C. Structural Models for $B_4H_8 \cdot 2P(CH_3)_3$. The newly isolated compound $B_4H_8 \cdot 2P(CH_3)_3$ represents one of the few B_4 hypoph class compounds so far isolated. The following reported compounds may be considered to belong to the B_4 hypoph class: $B_4H_8CO \cdot O(CH_3)_2$,^{9a} $B_4H_8 \cdot TMED$,¹⁷ and $B_4H_8 \cdot N(CH_3)_3 \cdot L$

where $L = N(CH_3)_3$, $N(CH_3)_2H$, $N(CH_3)H_2$, and NH_3 .^{2,20} No definitive structure determination has been reported for any of these compounds, although structures have been proposed for $B_4H_8 \cdot TMED$ on the basis of the NMR spectra of the compound.^{17,21} In view of the unique structures that have been found for the B_5 and B_6 hypoph compounds,^{18,22} the structures of the B_4 hypoph compounds would be of considerable interest and importance for the systematization of boron hydride chemistry. The bis(trimethylphosphine) adduct reported in this paper is fairly stable at room temperature, whereas the others, with the exception of $B_4H_8 \cdot TMED$, readily decompose even at low temperatures. The NMR study over a wide temperature range was thus possible for the phosphine compound.

The NMR data described earlier in this paper clearly indicate that the $B_4H_8 \cdot 2P(CH_3)_3$ molecule is nonrigid. At room temperature the hydrogen atoms in the B_4H_8 unit appear to migrate rapidly within the molecule and the boron atoms undergo a rapid environment change. As the temperature is lowered, the fluxional motion slows down as evidenced by the splitting of borane proton (H_B) signal and by the splitting of the high-field ¹¹B signal. A simple structural model for the compound may be visualized as that which results when a second $P(CH_3)_3$ is added to $B_4H_8 \cdot P(CH_3)_3$ at the most deshielded boron atom B_3 (structure I given below). The NMR data may be interpreted in terms of this structure, assuming that the molecules freeze into two static isomers, cis and trans forms with respect to the positions of the two phosphine groups relative to the B_4 framework which, in this case, would be nearly planar. The two high-field peaks at low temperatures are then attributed to the $B_{1,3}$ atoms of the cis and trans isomers. It has to be assumed, however, that the chemical shift values for the $B_{2,4}$ atoms and for the borane hydrogen atoms, as well as for the methyl protons and phosphorus atoms, are each nearly identical for the two isomers.

A consideration, based on the classical valence-bond structure description,²³ of possible tautomeric structures of the compound to rationalize the migration of the hydrogen atoms yields a series of structures as shown. Among these structures,

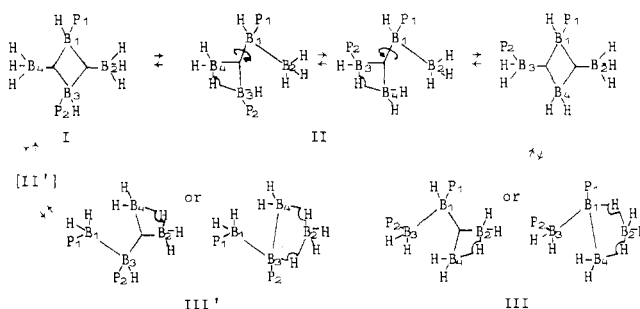

III (and III') can be another possible static structure which is consistent with the NMR data. It is assumed here again that the chemical shift values for the two phosphorus atoms and for the two kinds of methyl protons are each nearly identical. The structure (III) may be regarded as a derivative of $(CH_3)_3P \cdot B_3H_7$, in which one of the borane hydrogen atoms has been replaced by a $-BH_2P(CH_3)_3$ group at the B_1 atom. The six hydrogen atoms within the triborane unit would then be migrating rapidly even at the low temperatures to become indistinguishable from each other in the NMR spectra²⁴ but are distinguishable from the two hydrogen atoms in the $-BH_2P(CH_3)_3$ group because of the large enough shift difference (28 Hz) between the two kinds of hydrogen atoms compared with the rate of rearrangement $III \rightleftharpoons III'$ at the low temperature.

The above B_3H_7 derivative model for the B_4 hypoph compound is closely related to the structure of $B_4H_8 \cdot TMED$, which was proposed recently by Colquhoun.²¹ Furthermore, we find that the relation between the proposed structures of the two

B_4 hypho compounds resembles the relation between the structures of $B_3H_9 \cdot 2(\text{phosphine})$ and $B_3H_9 \cdot \text{TMED}$. Wallbridge et al. found that the structure of $B_3H_9 \cdot \text{TMED}$ can be regarded as a derivative of B_4H_8 with a $-\text{B}(\text{H})\text{N}(\text{CH}_3)_2\text{CH}_2\text{CH}_2\text{N}(\text{CH}_3)_2$ group attached to the apex boron atom of the B_4H_8 unit.¹⁹ This structure compares with the proposed structure of $B_4H_8 \cdot \text{TMED}$, which can be regarded as a B_3H_7 derivative, $B_3H_7-\text{B}(\text{H})\text{N}(\text{CH}_3)_2\text{CH}_2\text{CH}_2\text{N}(\text{CH}_3)_2$.²¹ The structures of the bis(phosphine) B_5 hypho compounds are different from that of the amine adduct in that one of the phosphine ligands is bonded to the apical boron atom of the pyramid-shaped B_5 framework and the other phosphine to one of the basal boron atoms.^{18,19} However, the bis(trimethylphosphine) adduct is known to be fluxional,¹⁸ and structures with the B_4H_8 derivative feature would be assumed by the molecule in the process of tautomeric rearrangement. Earlier, Shore et al. presented a scheme of tautomerism for $B_3H_9 \cdot 2P(\text{CH}_3)_3$.¹⁸ Shown here is its reproduction with extra steps added to indicated the B_4H_8 derivative feature of the intermediates (IV and V).²⁵ Ob-

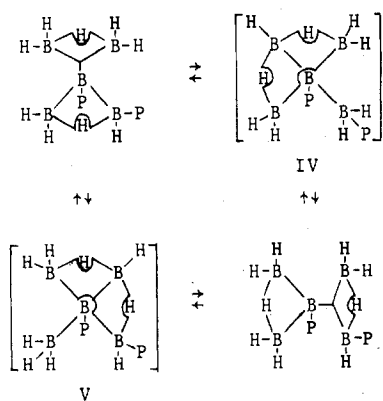

viously, structure IV compares with the $(\text{CH}_3)_3\text{P} \cdot B_3H_7$ derivative structure of $B_4H_8 \cdot 2P(\text{CH}_3)_3$ presented above.

Being informed of the structure of $B_3H_9 \cdot \text{TMED}$ and knowing that $B_4H_8 \cdot \text{TMED}$ is obtained by the alcoholysis of $B_3H_9 \cdot \text{TMED}$,¹⁷ one would readily assume that the B_3H_7 derivative structure would be reasonable for $B_4H_8 \cdot \text{TMED}$ as LB_3H_7 is known to be the product of the HCl protolysis of LB_4H_8 .^{2,26}

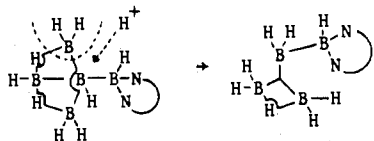

Similar to the transformation of the TMED adduct, the phosphine adduct $B_5H_9 \cdot 2P(\text{CH}_3)_3$ transforms to $B_4H_8 \cdot 2P(\text{C}-\text{H}_3)_3$ upon protolysis with HCl. It is noted that the removal of a BH_2 group from one of the basal positions in either the reported structure of $B_5H_9 \cdot 2P(\text{CH}_3)_3$ or the intermediate structure (IV or V), followed by the addition of H^+ , results in the B_3H_7 derivative structure identical with structure II or III as indicated. Structure II is thought to be unstable in view of the lack of the evidence for the formation of $B_3H_7 \cdot 2P(\text{CH}_3)_3$ as mentioned in section B of the Discussion.

Although the discussion presented above may favor III over I as the static structure of $B_4H_8 \cdot 2P(\text{CH}_3)_3$, the definitive structural study for the compound is yet incomplete. A further study is being conducted in an effort to obtain structural information on various hypho B_4 compounds.

Experimental Section

Chemicals. Laboratory stock pentaborane(11) and tetraborane(10), which had been prepared by the pyrolysis of diborane(6) in a hot-cold reactor,²⁷ were used. Pentaborane(11) was purified by the procedure described previously.² Trimethylphosphine was prepared from PCl_3

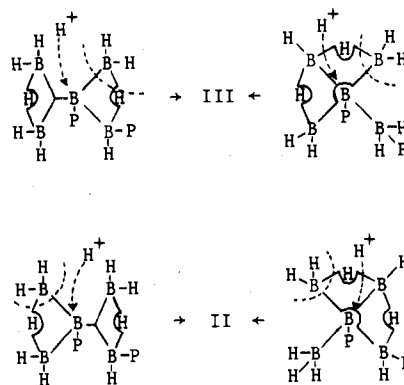

by the Grignard reaction, stored as a AgI complex,²⁸ generated from the complex by heating, and fractionated in the vacuum line. Bis(trimethylphosphine)-pentaborane(9) was prepared by the literature method,²⁹ using CH_2Cl_2 as the solvent. Laboratory stock pentaborane(9) was used after fractionation. The ^1H NMR spectrum of the phosphine adduct in CH_2Cl_2 was identical with that reported in the literature.¹⁸ Trimethylphosphine-triborane(7) was prepared by the reaction of tetraborane(10) with $(\text{CH}_3)_3\text{P}$. Anhydrous hydrogen chloride (Matheson Gas Products) was fractionated in the vacuum line. Reagent grade dichloromethane and tetrahydrofuran were stored over molecular sieves and LiAlH_4 , respectively, and were distilled from the containers into the vacuum line as needed.

Apparatus and Instruments. Throughout the experiments compounds were handled in vacuum lines. Dry nitrogen gas was admitted in the vacuum line whenever it was necessary. The NMR spectra were recorded on a Varian XL-100-15 instrument equipped with a spin-decoupler unit (Gyrocode). The observed frequencies were 100, 32.1, and 40.5 MHz for ^1H , ^{11}B , and ^{31}P nuclei, respectively. Solutions were transferred into NMR sample tubes within the vacuum-line system and the tubes sealed off. Some reactions were run in 10-mm o.d. regular Pyrex tubes, and the tube was placed in the probe for the ^{11}B NMR measurements. The mass spectrum was obtained on an AEI MS-30 mass spectrometer operating in the electron-impact mode at 70 eV.

Reactions of B_5H_{11} with $P(\text{CH}_3)_3$. In a typical reaction, a CH_2Cl_2 solution (3 mL) containing 1.60 mmol of B_5H_{11} was prepared in a reaction tube (Pyrex, 22-mm o.d.), and $P(\text{CH}_3)_3$ (4.89 mmol) was condensed into the tube at -196°C . (The molar ratio $P(\text{CH}_3)_3:B_5H_{11} = 3.1:1.0$.) The tube was allowed to warm to -80°C , while the reaction mixture was stirred. A white solid formed in the solution at this temperature. The reaction mixture was then allowed to warm to nearly room temperature. The solution became clear. The volatile components were then distilled out of the tube. A solid remained in the tube at the end of the distillation, and $(\text{CH}_3)_3\text{P} \cdot \text{BH}_3$ slowly sublimed from the solid to leave a less volatile residue behind. No noncondensable gas evolved during this entire process. The yield of $(\text{CH}_3)_3\text{P} \cdot \text{BH}_3$ was 144.4 mg (1.60 mmol). The distillate, which consisted of the solvent and recovered $P(\text{CH}_3)_3$, was treated with excess B_2H_6 to give 23.4 mg (0.26 mmol) of $(\text{CH}_3)_3\text{P} \cdot \text{BH}_3$. Unrecovered $P(\text{CH}_3)_3$ was, therefore, 4.63 mmol. Thus, the reaction stoichiometry was $B_5H_{11}:(\text{CH}_3)_3\text{P} \cdot \text{BH}_3 = 1.0$, and the composition of the residue was $B_4H_8 \cdot 1.9P(\text{CH}_3)_3$.

The samples for the NMR and mass spectral measurements were prepared in the sublimation-sampling apparatus which was described elsewhere.² For the sublimation, the entire apparatus was exposed to room temperature, and the cold finger was kept at 10°C . Usually the sublimation of the residue was virtually complete; only a trace of nonvolatile solid was left behind, if any.

The observed intensity ratio for the high-mass cutoff region in the mass spectrum of $B_4H_8 \cdot 2P(\text{CH}_3)_3$ was analyzed for the composition of ions, with the assumption of successive loss of pairs of hydrogen atoms from the parent ion $B_4H_8 \cdot 2P(\text{CH}_3)_3^+$. The best fit was obtained for a mixture of $B_4H_8 \cdot 2P(\text{CH}_3)_3^+$, $B_4H_6 \cdot 2P(\text{CH}_3)_3^+$, $B_4H_4 \cdot 2P(\text{CH}_3)_3^+$, and $B_4H_2 \cdot 2P(\text{CH}_3)_3^+$ in a 3.1:100:6.0:3.0 ratio. m/e (observed intensity, calculated intensity):³⁰ 206 (0.0, 0.0), 205 (1.5, 0.2), 204 (2.0, 3.1) 203 (10.0, 9.1), 202 (99.0, 98.2), 201 (91.5, 92.6), 200 (40.0, 39.5), 199 (11.0, 11.2), 198 (4.5, 5.2), 197 (3.5, 3.1), 196 (2.0, 1.0), 195 (0.0, 0.2), 194 (0.0, 0.0). The reaction stoichiometry and the mass spectrum analysis described above establish the formula $B_4H_8 \cdot 2P(\text{C}-\text{H}_3)_3$ for the less volatile solid product.

When the reactants were mixed in a molar ratio 2.6:1 [1.03 mmol of $\text{P}(\text{CH}_3)_3$ and 0.39 mmol of B_5H_{11}] and treated in a manner similar to that described above, a colorless mixture of solid and liquid resulted upon removal of the solvent and other volatile components. The ^{11}B NMR spectrum of the residue in CH_2Cl_2 showed the presence of $\text{B}_4\text{H}_8\cdot 2\text{P}(\text{CH}_3)_3$ (major component), $\text{B}_4\text{H}_8\cdot \text{P}(\text{CH}_3)_3$, and small amounts of $(\text{CH}_3)_3\text{P}\cdot\text{BH}_3$ and B_3H_8^- ion. Identified similarly in the volatile components were $(\text{CH}_3)_3\text{P}\cdot\text{BH}_3$ and small amounts of B_3H_9 and B_4H_{10} . When the mixing ratio was 2:1 [3.14 mmol of $\text{P}(\text{CH}_3)_3$ and 1.58 mmol of B_5H_{11}], the residue was a colorless liquid which gradually turned yellow. The yellow-tinged residue contained $(\text{CH}_3)_3\text{P}\cdot\text{B}_4\text{H}_8$, $(\text{C}-\text{H}_3)_3\text{P}\cdot\text{BH}_3$, $\text{B}_4\text{H}_8\cdot 2\text{P}(\text{CH}_3)_3$, B_3H_8^- , and other unidentified boron compounds, the relative amount of each being in this order.

Reaction of $\text{B}_5\text{H}_9\cdot 2\text{P}(\text{CH}_3)_3$ with HCl. A 0.87-mmol sample of $\text{B}_5\text{H}_9\cdot 2\text{P}(\text{CH}_3)_3$ was prepared in a 10-mm o.d. Pyrex tube equipped with a stopcock and was dissolved in about 2 mL of tetrahydrofuran. Anhydrous hydrogen chloride (0.89 mmol) was condensed above the frozen solution (-196°C), and the mixture was agitated by shaking at -80°C . The tube was then allowed to warm to room temperature and inserted into the NMR probe, and the spectra of the clear solution were examined. The presence of $\text{B}_4\text{H}_8\cdot 2\text{P}(\text{CH}_3)_3$ and $\text{BH}_2\text{Cl}\cdot\text{THF}$ (triplet at 4.3 ppm, $J_{\text{BH}} = 127$ Hz) was obvious in the spectrum which was taken immediately after the sample was warmed to room temperature. Very weak signals of $(\text{CH}_3)_3\text{P}\cdot\text{BH}_3$ and $\text{B}_4\text{H}_8\cdot \text{P}(\text{CH}_3)_3$ could be detected. The intensities of the $\text{B}_4\text{H}_8\cdot 2\text{P}(\text{CH}_3)_3$ and $\text{BH}_2\text{Cl}\cdot\text{THF}$ signals decreased, and the signals of $\text{B}_4\text{H}_8\cdot \text{P}(\text{CH}_3)_3$ and $\text{BH}_2\text{Cl}\cdot\text{P}(\text{CH}_3)_3$ (-18.0 ppm, $J_{\text{BP}} = 82$ Hz, $J_{\text{BH}} = 117$ Hz) grew in. Thus, in 10 min after the sample was warmed to room temperature, the molar ratio between $\text{B}_4\text{H}_8\cdot 2\text{P}(\text{CH}_3)_3$ and $\text{B}_4\text{H}_8\cdot \text{P}(\text{CH}_3)_3$ became about 2:3. Several other very weak signals of unknown origins were also detected. The secondary reaction is appropriately represented by

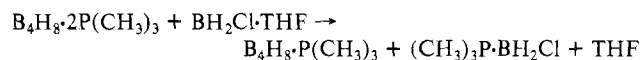

In another experiment, the HCl reaction was run in a CH_2Cl_2 solution in the presence of tetrahydrofuran and the reaction mixture was examined at low temperatures. The protolysis reaction was complete at -80°C , and the progress of the secondary reaction was not noticed up to 0°C . At 20°C the change occurred rapidly.

Reaction of $\text{B}_4\text{H}_8\cdot 2\text{P}(\text{CH}_3)_3$ with HCl. About 2 mL of tetrahydrofuran solution containing 0.67 mmol of $\text{B}_4\text{H}_8\cdot 2\text{P}(\text{CH}_3)_3$ was placed in a 10-mm o.d. Pyrex tube equipped with a stopcock and cooled to -80°C . A 0.57-mmol sample of anhydrous hydrogen chloride gas was then expanded through the stopcock into the tube. The gas was slowly absorbed by the solution as the tube was occasionally tapped to agitate the solution. The last small portion of the HCl gas was condensed into the tube at -196°C . During this HCl addition process a small amount of hydrogen gas (0.03 mmol) evolved. The tube was then placed in the NMR probe, and the spectra of the solution were examined. At -80°C broad signals of $(\text{CH}_3)_3\text{P}\cdot\text{B}_3\text{H}_7$ and $(\text{CH}_3)_3\text{P}\cdot\text{BH}_2\text{Cl}$ were seen. As the temperature was raised, the signals became sharper [B_1 at -45.9 ppm ($J_{\text{BP}} = 103$ Hz) and $\text{B}_{2,3}$ at -16.3 ppm], and the multiplet signal of $(\text{CH}_3)_3\text{P}\cdot\text{BH}_2\text{Cl}$ could be seen clearly at room temperature.

Stabilities of $\text{B}_4\text{H}_8\cdot 2\text{P}(\text{CH}_3)_3$ and $(\text{CH}_3)_3\text{P}\cdot\text{B}_3\text{H}_7$ toward $(\text{CH}_3)_3\text{P}$. A dichloromethane solution (2 mL) containing 1.15 mmol of $\text{B}_4\text{H}_8\cdot 2\text{P}(\text{CH}_3)_3$ was prepared, and 1.14 mmol of $\text{P}(\text{CH}_3)_3$ was condensed above the solution at -196°C . The solution was stirred for 1 h at room temperature, and its ^{11}B NMR spectrum was examined. The spectrum was that of pure $\text{B}_4\text{H}_8\cdot 2\text{P}(\text{CH}_3)_3$. Upon standing 36 h at room temperature, the solution had undergone a slight change as evidenced by the appearance of several new weak signals in its ^{11}B NMR spectrum. One of them, which appeared as a broad peak centered at -37.0 ppm, might be a superposition of $(\text{CH}_3)_3\text{P}\cdot\text{BH}_3$ and $\text{B}_2\text{H}_4\cdot 2\text{P}(\text{CH}_3)_3$ signals. Other new signals are weak and unidentified.

A dichloromethane solution (2 mL) containing 0.55 mmol of $(\text{C}-\text{H}_3)_3\text{P}\cdot\text{B}_3\text{H}_7$ and 0.56 mmol of $(\text{CH}_3)_3\text{P}$ was prepared at -80°C . Up to -20°C no change could be detected in the ^{11}B NMR spectra of the solution. At 0°C slow growth of a hump at -37 ppm was noticed. At room temperature the peak grew fast at the expense of the $(\text{C}-\text{H}_3)_3\text{P}\cdot\text{B}_3\text{H}_7$ signal intensity. The peak was a superposition of the $(\text{CH}_3)_3\text{P}\cdot\text{BH}_3$ doublet signal (^1H -spin decoupled) at -37.0 ppm and the broad signal of $\text{B}_2\text{H}_4\cdot 2\text{P}(\text{CH}_3)_3$ at -37.5 ppm (lit.³¹ value -37.4 ppm).

Acknowledgment. The authors gratefully acknowledge the

support of this work by the U.S. Army Research Office through Grant DAAG 29-76-G120. We thank Dr. D. K. Dalling of this department for providing us the 300-MHz proton NMR data and fruitful discussions.

Registry No. $\text{B}_4\text{H}_8\cdot 2\text{P}(\text{CH}_3)_3$, 66750-83-2; $\text{B}_4\text{H}_8\cdot \text{P}(\text{CH}_3)_3$, 71749-92-3; B_5H_{11} , 18433-84-6; $\text{B}_5\text{H}_9\cdot 2\text{P}(\text{CH}_3)_3$, 39661-74-0; $(\text{CH}_3)_3\text{P}\cdot\text{B}_3\text{H}_7$, 12543-29-2; $(\text{CH}_3)_3\text{P}\cdot\text{BH}_2\text{Cl}$, 64160-46-9.

References and Notes

- (1) On leave from Kawamura Junior College, Tokyo, Japan.
- (2) Dodds, A. R.; Kodama, G. *Inorg. Chem.* **1979**, *18*, 1465.
- (3) (a) Forsyth, M. W.; Hough, W. V.; Ford, M. D.; Hefferan, G. T.; Edwards, L. J. "Abstracts of Papers", 135th National Meeting of the American Chemical Society, Boston, Mass., April 1959; American Chemical Society: Washington, D.C., 1959; p 40M. (b) Parry, R. W.; Edwards, L. J. *J. Am. Chem. Soc.* **1959**, *81*, 3554.
- (4) Graham, W. A. G.; Stone, F. G. A. *J. Inorg. Nucl. Chem.* **1956**, *3*, 164. Stone, F. G. A. *Chem. Rev.* **1958**, *58*, 101. Coyl, T. D.; Stone, F. G. A. *Prog. Boron Chem.* **1964**, *1*, 83.
- (5) Shapiro, I.; Wilson, C. O.; Ditter, J. F.; Lehman, W. J. *Adv. Chem. Ser.* **1961**, No. 32, 127, ref 2 and references therein.
- (6) Harris, R. K. *Can. J. Chem.* **1964**, *42*, 2275.
- (7) 63.5 Hz for $(\text{CH}_3)_3\text{P}\cdot\text{BH}_3$ [Verkade, J. G.; King, R. W.; Heitsch, C. W. *Inorg. Chem.* **1964**, *3*, 884], 103 Hz for $(\text{CH}_3)_3\text{P}\cdot\text{B}_3\text{H}_7$ [this work], 118 Hz for $(\text{CH}_3)_3\text{P}\cdot\text{B}_4\text{H}_8$ [this work], and 105 Hz for $\text{B}_6\text{H}_{10}\cdot 2\text{P}(\text{CH}_3)_3$ [Mangion, M. M.; Hertz, R. K.; Denniston, M. L.; Long, J. R.; Clayton, W. R.; Shore, S. G. *J. Am. Chem. Soc.* **1976**, *98*, 449].
- (8) Bushweller, C. H.; Beall, H.; Grace, M.; Dewkett, W. J.; Bilofsky, H. S. *J. Am. Chem. Soc.* **1971**, *93*, 2145. Beall, H.; Bushweller, C. H.; Grace, M. *Inorg. Nucl. Chem. Lett.* **1971**, *7*, 641. Beall, H.; Bushweller, C. H. *Chem. Rev.* **1973**, *73*, 465.
- (9) (a) Spielman, J. R.; Burg, A. B. *Inorg. Chem.* **1963**, *2*, 1139. (b) Centofanti, L.; Kodama, G.; Parry, R. W. *Ibid.* **1969**, *8*, 2072. Paine, R. T.; Parry, R. W., *Ibid.* **1972**, *11*, 1237. Kondo, H.; Kodama, G. *Ibid.* **1979**, *18*, 1460.
- (10) LaPrade, M. D.; Nordman, C. E. *Inorg. Chem.* **1969**, *8*, 1669.
- (11) Schultz, D. R.; Parry, R. W. *J. Am. Chem. Soc.* **1958**, *80*, 4. Shore, S. G.; Parry, R. W. *Ibid.* **1958**, *80*, 8. Shore, S. G.; Parry, R. W. *Ibid.* **1958**, *80*, 12. Parry, R. W.; Shore, S. G. *Ibid.* **1958**, *80*, 15. Shore, S. G.; Giradot, P. R.; Parry, R. W. *Ibid.* **1958**, *80*, 20.
- (12) Kodama, G.; Parry, R. W. *Proc. Int. Congr. Pure Appl. Chem.* **1958**, *16*, 483. Kodama, G.; Parry, R. W. *J. Am. Chem. Soc.* **1960**, *82*, 6250.
- (13) Kodama, G.; Dunning, J. E.; Parry, R. W. *J. Am. Chem. Soc.* **1971**, *93*, 3372.
- (14) A. B.; Burg, Schlesinger, H. I. *J. Am. Chem. Soc.* **1937**, *59*, 780.
- (15) Edwards, L. J.; Hough, W. V.; Ford, M. D. *Proc. Int. Congr. Pure Appl. Chem.* **1958**, *16*, 475.
- (16) Edwards, L. J.; Hough, W. V. U.S. Patent 3 281 218 (Cl.23-358), Oct 25, 1966; appl. July 18, 1957; assigned to Callery Chemical Co.
- (17) Miller, N. E.; Miller, H. C.; Muettterties, E. L. *Inorg. Chem.* **1964**, *3*, 866.
- (18) Fratini, A. V.; Sullivan, G. W.; Denniston, M. L.; Hertz, R. K.; Shore, S. G. *J. Am. Chem. Soc.* **1974**, *96*, 3013.
- (19) Alcock, N. W.; Colquhoun, H. M.; Haran, G.; Sawyer, J. F.; Wallbridge, M. G. H. *J. Chem. Soc., Chem. Commun.* **1977**, 368.
- (20) Dodds, A. R. Ph.D. Thesis, The University of Utah, 1979.
- (21) Colquhoun, H. M. *J. Chem. Res. (S)* **1978**, 451.
- (22) The last reference given in ref 7.
- (23) Lipscomb, W. N. "Boron Hydrides"; Benjamin: New York, 1963; *Adv. Inorg. Chem. Radiochem.* **1959**, *1*, 117.
- (24) Like $(\text{CH}_3)_3\text{N}\cdot\text{B}_3\text{H}_7$ [Dodds, A. R.; Kodama, G. *Inorg. Chem.* **1976**, *15*, 741], $(\text{CH}_3)_3\text{P}\cdot\text{B}_3\text{H}_7$ is nonrigid even at -90°C as evidenced by the appearance of a single doublet signal for the H_β atoms (^{11}B -spin decoupled) and by the singlet features of the B_1 and $\text{B}_{2,3}$ signals in the normal ^{11}B NMR spectrum [Kodama, G., unpublished data].
- (25) Professor S. G. Shore of The Ohio State University, Columbus, Ohio, kindly informed us as one of the referees of this paper that he recently isolated an isomeric form of $\text{B}_5\text{H}_9\cdot 2\text{P}(\text{CH}_3)_3$ and found its structure, by the X-ray diffraction method, to be V.
- (26) The ^{11}B NMR spectra reported in ref 21 clearly indicate that the three boron atoms in the B_3H_7 group all become equivalent at higher temperatures. The data reported in ref 17 also suggested the same. The equivalency of the three boron atoms may be achieved by a rapid tautomerism which would proceed according to a scheme similar to that described for $\text{B}_4\text{H}_8\cdot 2\text{P}(\text{CH}_3)_3$ in the text. The absence of ligand on the B_3 framework in a structure similar to III would allow the B_1 atom to function the same as the B_2 and B_3 atoms.
- (27) Klein, M. J.; Harrison, B. C.; Solomon, I. J. *J. Am. Chem. Soc.* **1958**, *80*, 4149.
- (28) Thomas, R.; Eriks, K. *Inorg. Synth.* **1967**, *9*, 59. Mann, F. G.; Wells, A. F. *J. Chem. Soc.* **1938**, 702.
- (29) Savory, C. G.; Wallbridge, M. G. H. *J. Chem. Soc., Dalton Trans.* **1973**, 179.
- (30) Based on the natural abundances of carbon and boron isotopes, which were taken from, "Handbook of Chemistry and Physics", 54th ed.; The Chemical Rubber Co.: Cleveland, Ohio, 1973.
- (31) Hertz, R. K.; Denniston, M. L.; Shore, S. G. *Inorg. Chem.* **1978**, *17*, 2673.