

**Figure 1.**  $^{15}\text{N}$  NMR data for azo ligands and corresponding Pd(II) complexes.  $^{15}\text{N}$  chemical shifts are measured in ppm relative to formamide (112.4 ppm with respect to 0 ppm for anhydrous liquid ammonia), with 2% solutions of ligands and complexes in partially deuterated  $(\text{CH}_3)_2\text{SO}$  (15–20% deuterium content). All  $^{15}\text{N}$  signals appear as singlets.  $\Delta\delta = \delta(^{15}\text{N})_{\text{complex}} - \delta(^{15}\text{N})_{\text{ligand}}$ ; negative sign means shift to high field of the ligand  $^{15}\text{N}$  resonance.

[ $^{15}\text{N}$ ]amino-2-methylnaphthalene with unlabeled  $\text{NaNO}_2$  and subsequent coupling on 3,5-dimethylphenol led to **3** ( $^{15}\text{N}_\alpha$ ), which formed complex **4** ( $^{15}\text{N}_\alpha$ ) upon cyclopalladation with  $\text{Na}_2\text{PdCl}_4$ .

### Results and Discussion

The  $^{15}\text{N}$  chemical shifts of  $^{15}\text{N}_\alpha$ - and  $^{15}\text{N}_\beta$ -labeled ligands and complexes are presented and compared in Figure 1. Direct coordination of the palladium(II) center to the labeled azo nitrogen atom as in complex **2** causes a high-field shift of the  $^{15}\text{N}$  resonance by 151 ppm. This difference in chemical shift ( $\Delta\delta$ ) is in the same range and has the same direction toward higher field as was reported for protonated azobenzene compared with azobenzene (–150 ppm)<sup>13</sup> or for a Pt(II) complex with an *o,o'*-dihydroxyazobenzene ligand (–180 ppm).<sup>14</sup> When the  $^{15}\text{N}$ -labeled ligand **3** ( $^{15}\text{N}_\beta$ ) is cyclopalladated, the  $^{15}\text{N}_\beta$  resonance is shifted toward high field by almost 200 ppm, which suggests a ring closure at  $\text{N}_\beta$  and the formation of a six-membered ring structure. We cross-checked this result with the  $^{15}\text{N}_\alpha$ -labeled ligand **3** ( $^{15}\text{N}_\alpha$ ): cyclo-

palladation still results in a high-field shift of the resonance of  $^{15}\text{N}_\alpha$  adjacent to the unlabeled, coordinated nitrogen atom, but to a lesser extent (–50 ppm). This result, too, is compatible with other data ( $\Delta\delta = -60$  ppm for coordination of Pt(II) to the adjacent, unlabeled azo nitrogen).<sup>14</sup>

### Conclusion

The data discussed above (see Figure 1) unambiguously assign the six-membered chelate structure **4** to the Pd(II) complex obtained by peri palladation of the tri-ortho-methylated azo ligand **3**. To the best of our knowledge, the formation of a six-membered in preference of a five-membered chelate ring upon cyclopalladation of an N-donor ligand is unique. Our results do not exclude an intermediate cyclopalladation via a five-membered chelate and subsequent recoordination at  $\text{N}_\beta$  to the thermodynamically more stable complex **4** with the six-membered palladacycle.

**Registry No.** **1**, 1778-72-9; **2**, 81205-90-5; **3**, 81205-85-8; **4**, 81205-91-6.

Contribution from the Institute of General and Inorganic Chemistry and CNR Institute, University of Florence, Florence, Italy, and the Department of Chemistry, University of Stirling, Stirling, Scotland

### $\omega,\omega'$ -Dialkylated Tetraaza Linear Ligands as More Appropriate Reference Ligands for Tetraaza Macrocycles. A Comparison of 1,4,7,10-Tetraazadodecane with 3,6-Diaza-1,8-diaminooctane

Robert M. Clay,\* Heather McCormac, Mauro Micheloni, and Piero Paoletti\*

Received August 5, 1981

In making comparisons of the thermodynamic properties of metal complexes of tetraaza macrocyclic ligands with analogous noncyclic ligands, all authors to date have chosen simple linear tetraamines containing unsubstituted nitrogen atoms as reference ligands.<sup>1</sup> Thus for the smallest tetraaza macrocyclic ligand, 1,4,7,10-tetraazacyclododecane ( $L_1$ ) (I), the noncyclic tetraamine 3,6-diaza-1,8-diaminooctane ( $L_2$ ) (II) has been used as a reference.<sup>2</sup>

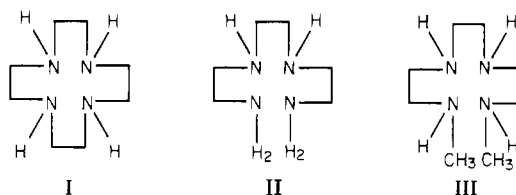

This practice, which undoubtedly originates from the ready availability of compounds such as  $L_2$ , is open to some criticism since  $L_1$  contains four secondary nitrogen atoms whereas  $L_2$  contains two primary and two secondary nitrogen atoms. Previous studies with N-methylated ethylenediamines indicated that replacing one primary with one secondary nitrogen caused the enthalpy of formation of the copper(II) complexes to become between 0.4 to 1.0 kcal mol<sup>-1</sup> less negative per substituted nitrogen atom.<sup>3</sup> Thus one might reasonably expect that the enthalpy of formation of the copper(II) complex of 1,4,7,10-tetraazadodecane ( $L_3$ ) (III) would be between some 1 or 2 kcal mol<sup>-1</sup> less negative than that of  $L_2$ .

(19) Fierz-David, H. E.; Mannhart, E. *Helv. Chim. Acta* **1937**, *20*, 1024–1031.

(20) Hiraki, K.; Fuchita, Y.; Takechi, K. *Inorg. Chem.* **1981**, *10*, 4316–4320.

\* To whom correspondence should be addressed: R.M.C., University of Stirling; P.P., University of Florence.

As far as the macrocyclic effect is concerned, this is by no means insignificant since the enthalpy of the metathetic reaction

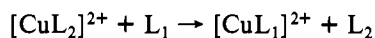

is only  $-1.1 \text{ kcal mol}^{-1}$ . A diminution of  $2 \text{ kcal mol}^{-1}$  in the enthalpy of formation of  $[\text{CuL}_2]^{2+}$  would therefore increase the macrocyclic enthalpy to ca.  $3 \text{ kcal mol}^{-1}$ . Similarly, using results previously obtained for stability constants of methylated ethylenediamines,<sup>4</sup> it would be reasonable to presume that the replacement of a primary with a secondary amine causes  $\Delta G^\circ$  to become about  $0.3 \text{ kcal mol}^{-1}$  less negative per substituted nitrogen atom with a corresponding increase in the macrocyclic free energy of ca.  $0.6 \text{ kcal mol}^{-1}$ . In view of the significant differences in the thermodynamic parameters for the macrocyclic effect suggested above, we decided to synthesize  $\text{L}_3$  and determine these values experimentally in order to ascertain whether the use of the simple, nonsubstituted linear ligands as references was justified and whether the earlier trend observed for N-substituted-methyl ethylenediamines was applicable to these more complicated tetraaza ligands.

### Experimental Section

**Synthesis of Ligand.** The ligand was made both in Florence and Stirling by essentially the same method. Tetratosyltriethylenetetramine was prepared by adding a solution of tosyl chloride in ether to stoichiometric amounts of triethylenetetramine and sodium hydroxide in water. Sodium hydride was now added to a solution of the tetratosylate in DMF until effervescence ceased; the mixture was filtered and the solution refluxed for 24 h with excess methyl iodide. The product was separated by adding water and hydrolyzed by treating with 98% sulfuric acid for 48 h at  $100^\circ\text{C}$ . The desired product was isolated from the reaction mixture as its tetrahydrochloride.

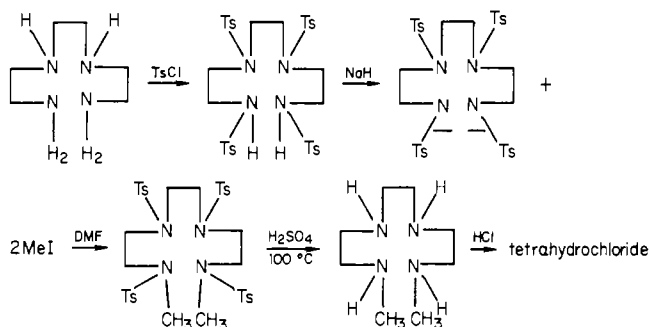

Anal. Calcd for the tetrahydrochloride,  $\text{C}_8\text{H}_{26}\text{N}_4\text{Cl}_4$ : C, 30.0; H, 8.19; N, 17.50; Cl, 44.30. Found in Florence sample: C, 30.3; H, 7.9; N, 17.5; Cl, 44.3. Found in Stirling sample: C, 29.9, H, 8.1; N, 17.3; Cl, 44.4.

**Determination of Enthalpies of Formation of Copper(II) Complex.** Separate determinations of the enthalpy of formation of the copper(II) complex were made in Florence and Stirling, in each case with a LKB Batch Microcalorimeter, according to the method we have previously described.<sup>5</sup>

In Florence 15% excess of ligand was used whereas in Stirling a 50% excess of ligand was employed. The results are as follows: Florence,  $-\Delta H^\circ = 21.1 \pm 0.2 \text{ kcal mol}^{-1}$ ; Stirling,  $-\Delta H^\circ = 21.1 \pm 0.3 \text{ kcal mol}^{-1}$ . This indicates a very satisfactory degree of agreement.

**Determination of Stability Constants of Copper(II) Complex (Also pK Values for Ligand).** This determination was carried out in Florence by potentiometric titrations, with use of previously described proce-

Table I. Electronic Spectra of Solutions of Copper Complexes

complex	$\lambda_{\text{max}}$ , nm	$\epsilon$ , $\text{M}^{-1} \text{ dm}^3 \text{ cm}^{-1}$	complex	$\lambda_{\text{max}}$ , nm	$\epsilon$ , $\text{M}^{-1} \text{ dm}^3 \text{ cm}^{-1}$
$\text{CuL}_1(\text{NO}_3)_2$	590	257	$\text{CuL}_3(\text{ClO}_4)_2$	570	163
$\text{CuL}_2(\text{ClO}_4)_2$	575	205			

Table II. Thermodynamic Parameters for Copper Complexes of  $\text{L}_1$ ,  $\text{L}_2$ , and  $\text{L}_3$  and for the Macrocyclic Effect Involving These Complexes

complex	$\log K_{\text{ML}}$	$-\Delta G^\circ$	$-\Delta H^\circ$	$T\Delta S^\circ$ , kcal/mol <sup>-1</sup>
$[\text{CuL}_1]^{2+}$	24.8	33.9	22.7	11.2
$[\text{CuL}_2]^{2+}$	20.2	27.6	21.6	6.0
$[\text{CuL}_3]^{2+}$ (predicted)		27.0	20.1	6.9
$[\text{CuL}_3]^{2+}$ (exptl)	20.93 (9)	28.6	21.1	7.5

macrocyclic effect	$-\Delta G^\circ$	$-\Delta H^\circ$	$T\Delta S^\circ$ , kcal mol <sup>-1</sup>
$[\text{CuL}_3]^{2+} + \text{L}_1 \rightarrow [\text{CuL}_1]^{2+} + \text{L}_2$	6.3	1.1	5.2
$[\text{CuL}_3]^{2+} + \text{L}_1 \rightarrow [\text{CuL}_1]^{2+} + \text{L}_1$			
predicted	6.9	2.6	4.3
observed	5.3	1.6	3.7

dures.<sup>6</sup> Concentrations of the titrants were determined with GRAN plots,<sup>7</sup> and the program MINQUAD<sup>8</sup> was used to determine values of the pK values and  $\log K_{\text{ML}}$  and  $\log K_{\text{MHL}}$ . Results are given in Table II.

### Results and Discussion

To enable a valid comparison to be made between the thermodynamic parameters of the complexes of the cyclic and non-cyclic ligands, it is necessary to show that complexes of the same type are formed with each ligand. Previously, the structure of the copper complexes of  $\text{L}_1$  and  $\text{L}_2$  have been shown to be five-coordinate in the solid state,<sup>9,10</sup> containing an arrangement in which the four nitrogens of the ligand are planar, the copper atom being some  $0.5 \text{ \AA}$  above this plane with the fifth coordination position occupied by a donor atom from the anionic species present. A square-pyramidal geometry is thus present. In nonaqueous solutions, conductivity measurements point to the existence of 1:1 electrolytes, whereas in aqueous solutions 2:1 electrolytes are formed, presumably by substitution of the anionic ligand species with solvent water. It is not known whether the complexes remain five-coordinate in aqueous solution but the similar electronic spectra of the solids and aqueous solutions suggest that they do. The electronic spectra of an aqueous solution of  $\text{CuL}_3(\text{ClO}_4)_2$  is sufficiently similar to that of  $[\text{CuL}_1]^{2+}$  and  $[\text{CuL}_2]^{2+}$  to leave little doubt that the same basic type of complex is formed and that the choice of  $\text{L}_3$  as a reference ligand for  $\text{L}_1$  is justified (Table I).

The results for  $\Delta H^\circ$  and  $\Delta G^\circ$  ( $\log K_{\text{ML}}$ ) for the copper(II) complex of  $\text{L}_3$  are given in Table II and compared with previously obtained values for  $\text{L}_1$  and  $\text{L}_2$ .<sup>2,11</sup> The thermodynamic parameters for the macrocyclic effect involving these ligands are also given in this table.

Values of the protonation constants for  $\text{L}_3$ , obtained at  $25^\circ\text{C}$  in  $0.5 \text{ M KNO}_3$  as part of the necessary data for determining  $\log K_{\text{ML}}$ , are  $\log K_1 = 10.75$  (1),  $\log K_2 = 9.68$  (1),  $\log K_3 = 7.59$  (7), and  $\log K_4 = 4.08$  (8). A value for  $\log K_{\text{MHL}}$  was also determined and found to be  $25.35$  (3). The enthalpy

- R. M. Clay, M. Micheloni, P. Paoletti, and W. V. Steel, *J. Am. Chem. Soc.*, **101**, 4119 (1979).
- M. Kodama and E. Kimura, *J. Chem. Soc., Chem. Commun.*, 326 (1975).
- P. Paoletti, L. Fabbrizzi, and R. Barbucci, *Inorg. Chim. Acta Rev.*, **7**, 43 (1973).
- R. M. Smith and A. E. Martell, "Critical Stability Constants", Vol. 2, Plenum Press, New York, 1975.
- A. Anichini, L. Fabbrizzi, P. Paoletti, and R. M. Clay, *J. Chem. Soc., Dalton Trans.*, 577 (1978).

- M. Micheloni, A. Sabatini, and A. Vacca, *Inorg. Chim. Acta*, **25**, 41 (1977).
- G. Gran, *Analyst (London)*, **77**, 661 (1952); F. J. C. Rossotti and H. Rossotti, *J. Chem. Educ.*, **42**, 375 (1965).
- A. Sabatini, A. Vacca, and P. Gans, *Talanta*, **21**, 53 (1974).
- R. M. Clay, P. Murray-Rust, and J. Murray-Rust, *Acta Crystallogr., Sect. B*, **B35**, 1894 (1979).
- G. Marongiu, E. C. Lingafelter, and P. Paoletti, *Inorg. Chem.*, **8**, 2763 (1969).
- R. Barbucci, L. Fabbrizzi, and P. Paoletti, *Coord. Chem. Rev.*, **8**, 31 (1972).

of formation of the complex  $[\text{CuL}_3]^{2+}$  is 0.5 kcal mol<sup>-1</sup> less negative than that of  $[\text{CuL}_2]^{2+}$ . This difference is rather smaller than would be predicted from the data available for methylated ethylenediamines. On the other hand, the free energy of formation is 1.0 kcal mol<sup>-1</sup> more negative than that of  $[\text{CuL}_2]^{2+}$  rather than 0.6 kcal mol<sup>-1</sup> less negative, which would be predicted on the same basis. In terms of the macrocyclic effect, we can now compare the enthalpic and entropic contributions to the macrocyclic free energy. The macrocyclic complex can be seen to be 1 kcal mol<sup>-1</sup> less stable than previously determined with reference to a nonsubstituted reference ligand, with a small increase in the enthalpic contribution of 0.5 kcal mol<sup>-1</sup> and a decrease in the entropic contribution ( $T\Delta S^\circ$ ) of 1.5 kcal mol<sup>-1</sup>.

It would be dangerous to draw too many conclusions or read too much significance into these results since the differences reported with the N-substituted reference ligand are small and are at the limit of the experimental method. **We can, however, satisfactorily conclude that the original choice of reference ligands for the tetraaza macrocycles, namely, the series of nonsubstituted linear polyamines similar to L<sub>2</sub>, was entirely appropriate.** It is not therefore necessary to modify the interpretation of the macrocyclic effect which has been made on the basis of these earlier results, namely, in terms of a favorable entropy contribution and an enthalpy contribution which varies with the relative matching of the metal ion to the ligand in terms of size, geometric requirements, and chemical affinity. What is perhaps more surprising is that the effect of alkylation of the nitrogens does not result in such a large difference in  $\Delta H^\circ$  and  $\Delta G^\circ$  as was observed for ethylenediamine and highlights the dangers of making comparisons of this type. It is most likely that the almost identical values of  $\Delta H^\circ$  for  $[\text{CuL}_2]^{2+}$  and  $[\text{CuL}_3]^{2+}$  result from the very similar structures and bond distances within the two complexes since the "bite" of ligands containing four nitrogen donors linked by two adjacent ethylenic bridges seems too small to accommodate most transition metals and results in the type of structures already discussed for  $[\text{CuL}_1]^{2+}$  and  $[\text{CuL}_2]^{2+}$ .

**Acknowledgment.** We wish to thank Dr. M. Bartolini for technical help and NATO for providing a travel grant.

**Registry No.** L<sub>3</sub>·4HCl, 27162-57-8;  $\text{CuL}_1(\text{NO}_3)_2$ , 64413-40-7;  $\text{CuL}_2(\text{ClO}_4)_2$ , 70289-70-2;  $\text{CuL}_3(\text{ClO}_4)_2$ , 80925-80-0; triethylenetetramine, 112-24-3.

Contribution from the Department of Chemistry,  
Faculty of Science, Shizuoka University,  
Oya, Shizuoka 422, Japan

### Circular Dichroism Spectra and Stereoselective Formation of Some Complexes of the Type $[\text{Co}(\text{phen})_2(\text{am})]^{2+}$

Akira Tatehata

Received July 7, 1981

In the series of the complexes  $[\text{Co}(\text{phen})_{3-x}(\text{am})_x]^{n+}$  (where phen is 1,10-phenanthroline and am is an  $\alpha$ -amino acid anion,  $x = 0-3$ ), the circular dichroism (CD) spectra of this series of complexes except for  $x = 1$ , that is,  $[\text{Co}(\text{phen})_3]^{3+}$  ( $x = 0$ ),<sup>1,2</sup>  $[\text{Co}(\text{phen})(\text{am})_2]^{2+}$  ( $x = 2$ ),<sup>3,4</sup> and  $[\text{Co}(\text{am})_3]^{3+}$  ( $x = 3$ ),<sup>5-9</sup> have

been studied extensively. We have now completed the series. In the present work, some of the new complexes  $[\text{Co}(\text{phen})_2(\text{am})]^{2+}$  have been prepared and separated into the optical isomers. The amino acids studied were glycine, (*S*)-alanine, (*S*)-phenylalanine, (*S*)-leucine, (*2S,3S*)-isoleucine, and (*S*)-valine. The CD spectra and the stereoselectivity in the formation of the diastereoisomers of the  $[\text{Co}(\text{phen})_2(\text{S-am})]^{2+}$  have been discussed, being compared with those of the corresponding ethylenediamine complexes  $[\text{Co}(\text{en})_2(\text{S-am})]^{2+}$ . A coordinated amino acid in the  $[\text{Co}(\text{en})_2(\text{S-am})]^{2+}$  had been considered to have little stereoselectivity owing to the planarity of the chelate ring. However, it has been found that in  $[\text{Co}(\text{phen})_2(\text{S-am})]^{2+}$ , the great stereoselectivity in the formation of the diastereoisomers was observed and an inverse relationship for the preferred absolute configuration exists between the phenanthroline complexes and the corresponding ethylenediamine complexes.

### Experimental Section

**Reagents.** Amino acids were purchased from Nippon Rikagaku Yakuhin Co., Tokyo, except for glycine and (*S*)-alanine, which were obtained from Wako Pure Chemical Industries, Ltd. The reported specific rotations at 589 nm were as follows: (*S*)-alanine, +14.0–+15.0° in 6 N HCl; (*S*)-phenylalanine, -34.3° in water; (*S*)-leucine, +15.2° in 6 N HCl; (*2S,3S*)-isoleucine, +40.9° in 6 N HCl; (*S*)-valine, +27.5° in 6 N HCl.

**Preparation and Separation of Isomers.** The (amino acid)bis(phenanthroline)cobalt(III) ions  $[\text{Co}(\text{phen})_2(\text{am})]^{2+}$  were prepared by the method of Ito et al. with the modification using methanol as a solvent.<sup>10</sup> The amino acid (2 mmol, 0.15 g for glycine) was dissolved in methanol (50 mL) containing an equimolar amount of sodium ethylate (2 mmol, 0.14 g). Solid *cis*- $[\text{Co}(\text{phen})_2\text{Cl}_2]\text{Cl}\cdot 3\text{H}_2\text{O}$  (1.7 mmol, 1.0 g) was added to the solution. The mixture was kept on a water bath at 40 °C for 3 h with stirring. The resulting orange red solution was diluted with water and passed through a CM-Sephadex column ( $\phi$  2.7 × 35 cm) to remove the reaction byproducts. The desired complex (orange red, 2+ charged species) was collected by elution with a 0.3 M NaCl solution. Half of the solution containing the desired complex was poured into a column ( $\phi$  2.7 × 130 cm) of SP-Sephadex C-25 and eluted with a 0.08 M  $\text{Na}_2[\text{Sb}_2(\text{L-tart})_2]$  solution for the glycinate complex. The elution for the optically active (*S*)-amino acid complexes was carried out with a 0.1 M  $\text{Na}_2\text{SO}_4$  solution. In every case the adsorbed orange red complex separated into two bands. So that the elution curves could be obtained, the eluate was divided into fractions of 15 mL each by an automatic fraction collector and the absorbance at the maximum wavelength of the first absorption band of the isomer was plotted against the eluate volume. First the (+)<sub>D</sub> isomer was eluted and then the (-)<sub>D</sub> isomer followed. The eluates of these two bands were diluted separately about ten times with water, and then the solution was passed through an SP-Sephadex short column ( $\phi$  2.5 × 5 cm) in each case. The complex on the exchanger was eluted with a 1 M NaCl solution. Sodium perchlorate solution was added to this eluate, and the solution was kept in a refrigerator. Orange red crystals were filtered off, washed with an ethanol-water (1:1) solution and then ethanol, and recrystallized from water and air-dried at room temperature.

**Measurements.** The absorption spectra were obtained on a Shimadzu MPS-50L recording spectrophotometer. The optical rotations were measured with a Union automatic polarimeter PM-101 in a 1-cm cell. The CD spectra were recorded on a JASCO J-40 CS spectropolarimeter with 1-cm or 1-mm cells. These measurements were carried out in aqueous solutions at room temperature. The 90-MHz <sup>1</sup>H NMR spectra were measured at about 35 °C on a Varian EM-390

- (1) J. Ferguson, C. J. Hawkins, N. A. Kane-Maguire, and H. Lip, *Inorg. Chem.*, **8**, 771 (1969).
- (2) L. S. Döllimore and R. D. Gillard, *J. Chem. Soc., Dalton Trans.*, 933 (1973).
- (3) T. Yasui and B. E. Douglas, *Inorg. Chem.*, **10**, 97 (1971).

- (4) T. Yasui, *Bull. Chem. Soc. Jpn.*, **48**, 454 (1975).
- (5) B. E. Douglas and S. Yamada, *Inorg. Chem.*, **4**, 1561 (1965).
- (6) T. Yasui, J. Hidaka, and Y. Shimura, *Bull. Chem. Soc. Jpn.*, **38**, 2025 (1965).
- (7) R. G. Denning and T. S. Piper, *Inorg. Chem.*, **5**, 1056 (1966).
- (8) E. Larsen and S. F. Mason, *J. Chem. Soc. A*, 313 (1966).
- (9) M. Shibata, H. Nishikawa, and Y. Nishida, *Bull. Chem. Soc. Jpn.*, **39**, 2310 (1966).
- (10) H. Ito, J. Fujita, and K. Saito, paper presented at the 23rd Annual Meeting of the Chemical Society of Japan, Tokyo, 1970; see Abstract II, 13318.