

Acknowledgment is made to the Natural Sciences and Engineering Research Council (NSERC) of Canada, the British Columbia Health Care Research Foundation, and Sigma Xi for operating grants, to the NSERC for a University Research Fellowship (C.O.), to the UBC for a University Graduate Fellowship (W.O.N.), to the Walter C. Sumner Foundation for a Memorial Fellowship (G.A.W.), and to Professor W. R. Harris

for a preprint of ref 41.

Registry No. Ga(mpp)₃, 112506-09-9; ⁶⁷Ga(mpp)₃, 124821-95-0; Ga(dpp)₃, 123923-62-6; ⁶⁷Ga(dpp)₃, 124821-94-9; Ga(mepp)₃, 121542-76-5; In(mpp)₃, 116724-46-0; In(dpp)₃, 116699-26-4; In(mepp)₃, 123923-63-7; ⁶⁷Ga(citrate), 41183-64-6; ⁶⁷Ga(*l*-mimosine), 124821-96-1; ⁶⁷Ga(hmpp)₃, 124821-97-2; ⁶⁷Ga, 14119-09-6.

Contribution from the Edward Mallinckrodt Institute of Radiology, Washington University School of Medicine, St. Louis, Missouri 63110

A Novel Hexachelating Amino-Thiol Ligand and Its Complex with Gallium(III)

Dennis A. Moore,[†] Phillip E. Fanwick,[‡] and Michael J. Welch*

Received June 12, 1989

The ligand 1,4,7-tris(2-mercaptoethyl)-1,4,7-triazacyclononane, TS-TACNH₃ (**1**), was synthesized from the parent amine, TACN, by reaction with ethylene sulfide in benzene. TS-TACNH₃ undergoes reaction with Ga(NO₃)₃·9H₂O in ethanol to give the neutral complex Ga(TS-TACN) (**2**). The complex may be recrystallized from dichloromethane as pale pink needles of the disolvate, in monoclinic space group *P*₂₁/*n* (No. 14), with *a* = 9.313 (3) Å, *b* = 20.108 (7) Å, *c* = 11.921 (3) Å, and β = 96.71 (1)°. There are four molecules of complex and two molecules of solvation (CH₂Cl₂) present per unit cell. The gallium is fully chelated in a slightly distorted octahedral environment by the three amine nitrogens and the three thiolate sulfurs. For comparison, the Ga³⁺ complex of the similarly hexachelating ligand 1,4,7-triazacyclononane-1,4,7-triacetic acid, NOTA, is also presented. The complex Ga(NOTA) (**3**), crystallizes from boiling water also as pale pink needles, in monoclinic space group *P*₂₁/*n* (No. 14), with *a* = 8.835 (3) Å, *b* = 13.456 (2) Å, *c* = 11.914 (5) Å, β = 105.57 (2)°, and *Z* = 4. Again, the metal center is fully chelated in a slightly distorted octahedral environment. The degree of distortion may be expressed as trigonal twist, φ, where φ = 0° for a true octahedron and φ = 60° for a trigonal prism. While both Ga(TS-TACN) and Ga(NOTA) are potentially isostructural, in regard to coordination geometry, with trigonal-prismatic Fe(NOTA) (φ = 34.8°), the gallium(III) complexes are only slightly distorted from a regular octahedral coordination sphere (Ga(NOTA) φ = 12.4° and Ga(TS-TACN) φ = 10.4°). Preliminary results indicate ⁶⁸Ga(TS-TACN) to be stable in vivo versus the blood protein transferrin, indicating a relatively high stability constant for this hexachelating ligand.

Introduction

Research in our group is directed toward the design of ligand systems that have the potential of forming highly stable complexes of gallium(III).¹ High stability is required of potential new radiopharmaceuticals containing ⁶⁸Ga³⁺ for the species to maintain its integrity in vivo. Generally, this means taking advantage of the increase in ligand binding strength of polychelating versus mono- or dichelating ligands, in order to prevent hydrolysis of exchange with the blood protein transferrin. Previous work by Mathias et al.² has demonstrated that derivatives of ethylenediamine form stable pentachelate complexes with ¹¹¹In³⁺ and ⁶⁸Ga³⁺ versus transferrin. However, these ligands present the metal center with an N₂O₄⁴⁻ coordination sphere, thereby producing an anionic complex when chelated to gallium(III). Such charged complexes are generally low in lipophilicity. High lipophilicity of radioactively labeled metal complexes is required for imaging of organs such as the brain or heart.³

Neutral M(III) tris complexes of 3-hydroxy-4-pyronates, where M is aluminum and gallium, have been described by Orvig et al.⁴ While these hydrophilic complexes are stable versus hydrolysis by water, it is unclear if such ML₃ species will be stable in vivo. Previously, we have shown that the hexachelating ligand 1,4,7-tris(3,5-dimethyl-2-hydroxybenzyl)-1,4,7-triazacyclononane (TX-TACNH₃) (Figure 1), whose coordination sphere consists of an N₃O₃³⁻ core, forms a stable complex with gallium(III).¹ The analogous radioactively labeled ⁶⁸Ga complex forms a highly lipophilic, neutral species that is not subject to exchange with transferrin and does exhibit uptake by the heart with blood clearance via the liver.⁵ The inability of the radioactive complex to penetrate the blood-brain barrier is believed to be due to the large size of the complex.⁶

As part of an extension of this class of ligand, we now report the synthesis and characterization of a new hexachelating ligand, 1,4,7-tris(2-mercaptoethyl)-1,4,7-triazacyclononane (TS-TACNH₃) (Figure 2), and its complex with gallium(III). This ligand will present the Ga³⁺ center with an N₃S₃³⁻ core, thereby avoiding unwanted size, charge, and hydrophilic properties, to produce a small, neutral complex of potential radiopharmaceutical interest. We have also included the solid-state crystal structure of the complex formed from Ga³⁺ and the similarly hexachelating ligand 1,4,7-triazacyclononane-1,4,7-triacetic acid (NOTA) (Figure 3) for structural comparison.

Experimental Section

(A) General Comments. Ga(NO₃)₃·9H₂O was obtained from Morton-Thiokol. Ethylene sulfide was obtained from Aldrich. Both were used without further purification. 1,4,7-Triazacyclononane (TACN)⁷ and the monopotassium salt of 1,4,7-triazacyclononane-1,4,7-triacetic acid (NOTA)^{8,9} were prepared as reported in the literature. All solvents were reagent grade and used without additional purification. All NMR experiments were performed on a 7.05-T Varian XL-300 spectrometer (Varian Instruments Group, Palo Alto, CA). ¹H (300 MHz) and ¹³C (75 MHz) NMR spectra were internally referenced to tetramethylsilane,

- (1) Moore, D. A.; Fanwick, P. E.; Welch, M. J. *Inorg. Chem.* **1989**, *28*, 1504.
- (2) Mathias, C. J.; Sun, Y.; Welch, M. J.; Green, M. A.; Thomas, J. A.; Wade, K. R.; Martell, A. E. *Nucl. Med. Biol.* **1988**, *15*, 69.
- (3) (a) For brain, Tc-PnAO: Holm, S.; Andersen, A. R.; Vorstrup, S.; Lassen, N. A.; Paulson, O. B.; Holmes, R. A. *J. Nucl. Med.* **1985**, *26*, 1129. (b) For heart, Tc-BATO: Coleman, R. E.; Maturi, M.; Nunn, A. D.; Eckelman, W.; Juri, P. N.; Cobb, F. R. *J. Nucl. Med.* **1986**, *27*, 893.
- (4) Finnegan, M. M.; Lutz, T. G.; Nelson, W. O.; Smith, A.; Orvig, C. *Inorg. Chem.* **1987**, *26*, 2171.
- (5) Moore, D. A.; Welch, M. J.; Wade, K. R.; Martell, A. E.; Motekaitis, R. J. Presented at the Seventh International Symposium on Radio-pharmaceutical Chemistry, Groningen, The Netherlands, July 4-8, 1988; Abstract 156; *J. Labelled Compd. Radiopharm.* **1989**, *26*, 362.
- (6) Levin, V. A. *J. Med. Chem.* **1980**, *23*, 683.
- (7) White, D. W.; Karcher, B. A.; Jacobson, R. A.; Verkade, J. G. *J. Am. Chem. Soc.* **1979**, *101*, 4921.
- (8) Takahashi, M.; Takamoto, S. *Bull. Chem. Soc. Jpn.* **1977**, *50*, 3413.
- (9) van der Merwe, M. J.; Boeyens, J. C. A.; Hancock, R. D. *Inorg. Chem.* **1983**, *22*, 3490.

[†] Present address: Mallinckrodt Medical, Inc., 675 McDonnell Blvd., P.O. Box 5840, St. Louis, Missouri 63134.

[‡] Present address: Department of Chemistry, Purdue University, West Lafayette, Indiana 47907.

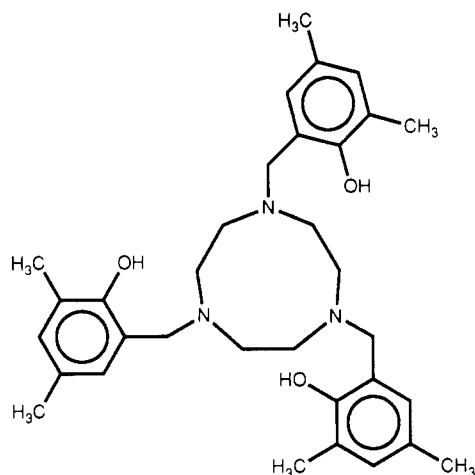

Figure 1. 1,4,7-Tris(3,5-dimethyl-2-hydroxybenzyl)-1,4,7-triazacyclononane, TX-TACNH₃.

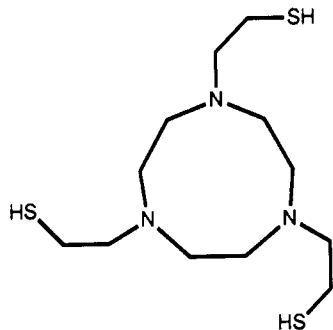

Figure 2. 1,4,7-Tris(2-mercaptoethyl)-1,4,7-triazacyclononane, TS-TACNH₃.

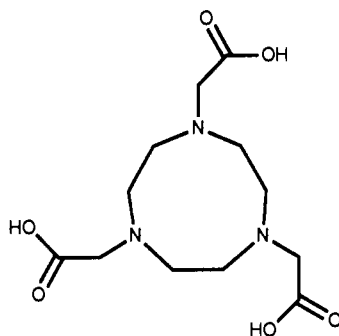

Figure 3. 1,4,7-Triazacyclononane-1,4,7-triacetic acid, NOTA.

or the sodium salt of 3-(trimethylsilyl)propionic-2,2,3,3-*d*₄ acid, where appropriate. ¹³C NMR peak assignments were made from gated decoupled spectra. Melting points were determined by using an Electrothermal melting point apparatus. Mass spectral data were obtained from a VG-ZAB-3F mass spectrometer and processed by using an associated VG-11-250 data system. Microanalyses were performed by Galbraith Laboratories, Inc., Knoxville, TN.

(B) Synthesis of 1,4,7-Tris(2-mercaptoethyl)-1,4,7-triazacyclononane (TS-TACNH₃) (1). To a 100-mL, two-neck, round-bottom flask, fitted with a reflux condenser and a serum stopper, containing 1.00 g (7.74 × 10⁻³ mol) of TACN in 50 mL of benzene, and flushed with N₂, was added via syringe 2.85 g (4.74 × 10⁻² mol) of ethylene sulfide. After the mixture was stirred for 3 h, the solvent was removed by rotoevaporation, giving 1.9 g of pale yellow oil. Completeness of the reaction may be estimated by observing the ¹H NMR data (20 °C, C₆D₆): δ 1.68 (thiol proton, s, 1 H), 2.25 (CH₂ α to S, m, 2 H), 2.40 (CH₂ α to N, overlapping m and s, 6 H). The oil was dissolved in 100 mL of 2% (v/v) concentrated HCl/ethanol, and the solution was cooled to 0 °C and allowed to sit overnight to effect crystallization. Yield: 2.07 g (68.3% based on TACN) of white flowery crystals of the salt TS-TACNH₃·2HCl·1/2H₂O (1a). ¹H NMR (20 °C, D₂O): δ 2.77 (CH₂ α to S, t, 1 H, J_{H₂-H₈} = 5.8 Hz), 3.25 (CH₂ β to S, t, 1 H, J_{H₂-H₈} = 5.8 Hz), 3.33 (TACN ring CH₂'s, s, 2 H). ¹³C{¹H} NMR (20 °C, D₂O): δ 21.23 (CH₂ α to S), 51.94 (TACN ring CH₂'s), 81.88 (CH₂ β to S). MS-FAB gives

Table I. Crystallographic Data for Ga(TS-TACN) (2) and Ga(NOTA) (3)

	2	3
formula	GaCl ₄ S ₃ N ₃ C ₁₄ H ₂₈	GaO ₆ N ₃ C ₁₂ H ₁₈
fw	546.12	370.01
space group	P2 ₁ /n (No. 14)	P2 ₁ /n (No. 14)
a, Å	9.313 (3)	8.835 (3)
b, Å	20.108 (7)	13.456 (2)
c, Å	11.921 (3)	11.914 (5)
β, deg	96.71 (1)	105.57 (2)
V, Å ³	1364 (1)	2217 (2)
Z	6	4
λ (Mo Kα), Å	0.70930	0.70930
ρ _{calc} , g cm ⁻³	2.290	1.801
μ, cm ⁻¹	28.00	20.42
transm coeff	1.000–0.798	1.000–0.441
T, °C	20	-109
R(F _o)	0.053	0.025
R _w (F _o)	0.067	0.035

M + H at *m/z* 310. Anal. Calcd for C₁₂H₃₀N₃O₆S₃Cl₂: C, 36.82; H, 7.72. Found: C, 36.81; H, 8.16.

(C) Synthesis of Ga(TS-TACN)·2CH₂Cl₂ (2). To a solution containing 2.70 g (6.46 × 10⁻³ mol) of Ga(NO₃)₃·9H₂O in 100 mL of ethanol was added 2.00 g (6.46 × 10⁻³ mol) of TS-TACNH₃ (1). Immediately an off-white precipitate formed. This material was collected by filtration, washed with fresh ethanol and diethyl ether, and allowed to air-dry. The crude product was dissolved in boiling dichloromethane, and the solution was filtered and concentrated by evaporation. When the mixture was cooled to room temperature, pale pink needles were deposited in the flask. Yield: 1.89 g (53.6% based on Ga(NO₃)₃·9H₂O) of the dichloromethane disolvate. ¹H NMR (20 °C, CD₂Cl₂): δ 2.71 (overlapping m's, 5 H), 2.87 (m, 1 H), 3.03 (m, 1 H), 3.42 (m, 1 H). ¹³C{¹H} NMR (20 °C, CD₂Cl₂): δ 25.83 (CH₂ α to S), 48.58 (CH₂ in TACN ring), 55.13 (other CH₂ in TACN ring), 61.29 (CH₂ β to S). MS-FAB gives M + H at *m/z* 370/372, displaying the expected isotopic pattern for natural abundance ^{69/71}Ga. Even after the crystals were carefully pulverized, followed by prolonged in vacuo drying at 50 °C, only 75% of the dichloromethane present in the disolvate could be removed. Anal. Calcd for GaC₁₂H₂₄N₃S₃·1/2CH₂Cl₂: C, 35.86; H, 6.02; N, 10.04; S, 22.97; Ga, 16.65. Found: C, 35.70; H, 6.27; N, 9.98; S, 23.28; Ga, 15.82.

(D) Synthesis of Ga(NOTA) (3). This complex was prepared exactly as the analogous iron compound. The complex was recrystallized from boiling H₂O as pink needles. ¹H NMR (20 °C, D₂O): δ 3.13 (TACN ring CH₂, m, 1 H), 3.42 (other TACN ring CH₂, m, 1 H), 3.81 (acetate CH₂, s, 1 H). ¹³C{¹H} NMR (20 °C, D₂O): δ 60.18 (TACN ring CH₂), 68.93 (acetate CH₂), 182.30 (acetate carbonyl).

(E) X-ray Diffraction Studies of Ga(TS-TACN) (2) and Ga(NOTA) (3). Single crystals of 2 were grown from a saturated dichloromethane solution at room temperature. Suitable crystals of 3 were obtained from a saturated water solution. Data for both structures were collected on an Enraf-Nonius CAD4 diffractometer using Mo Kα radiation. While data for 2 were collected at room temperature, data for 3 were collected at -109 °C. An empirical absorption correction was applied to both data sets.¹⁰ Positions for hydrogen atoms were calculated by assuming idealized geometry and a bond distance of 0.95 Å. All data reduction and structure refinement was carried out by using the Enraf-Nonius structure determination package. Crystallographic data and details of data collection for 2 and 3 are presented in Table I.

Results and Discussion

(A) Synthesis of 1,4,7-Tris(2-mercaptoethyl)-1,4,7-triazacyclononane (1). TS-TACNH₃ (1) may be readily synthesized by the reaction of 1,4,7-triazacyclononane with ethylene sulfide in warm (50 °C) benzene. Similar insertion reactions for TACN have been reported in the literature.¹¹ Oligomerization, via

- (10) Walker, N.; Stuart, D. *Acta Crystallogr., Sect. A* **1983**, *A39*, 158.
 (11) (a) Insertion of amine into ethylene sulfide: Wineman, R. J.; Gollis, M. H.; Jones, J. C.; Pomponi, A. M. *J. Org. Chem.* **1962**, *27*, 4222. (b) For similar insertion reactions involving TACN: Belal, A. A.; Farrugia, L. J.; Peacock, R. D.; Robb, J. *J. Chem. Soc., Dalton Trans.* **1989**, 931. Sayer, B. A.; Michael, J. P.; Hancock, R. D. *Inorg. Chim. Acta* **1983**, *77*, 163. Gahon, L. R.; Lawrence, G. A.; Sargeson, A. M. *Aust. J. Chem.* **1982**, *35*, 1119. (c) There is also a comprehensive review of TACN, derivatives and complexes, by: Chaudhuri, C.; Wiegardt, K. *Progress in Inorganic Chemistry*; Lippard, S. J., Ed.; John Wiley & Sons: New York, 1987.

Table II. Bond Distances (Å) and Selected Bond Angles (deg) with Estimated Standard Deviations for Ga(TS-TACN) (2)

Bond Distances					
Ga-S1	2.335 (1)	Ga-S4	2.344 (1)	Ga-S7	2.337 (1)
Ga-N1	2.201 (4)	Ga-N4	2.202 (4)	Ga-N7	2.221 (4)
S1-C12	1.831 (5)	S4-C42	1.828 (6)	S7-C72	1.829 (5)
N1-C2	1.499 (6)	N4-C3	1.484 (6)	N7-C6	1.466 (7)
N1-C9	1.479 (6)	N4-C5	1.486 (6)	N7-C8	1.498 (6)
N1-C11	1.485 (7)	N4-C41	1.492 (6)	N7-C71	1.478 (7)
C11-C12	1.511 (8)	C41-C42	1.506 (8)	C71-C72	1.508 (8)
C2-C3	1.514 (7)	C5-C6	1.537 (8)	C8-C9	1.515 (8)
Bond Angles					
S1-Ga-S4	97.88 (5)	S1-Ga-S7	98.87 (5)	S1-Ga-N1	85.1 (1)
S1-Ga-N4	96.5 (1)	S1-Ga-N7	163.9 (1)	S4-Ga-S7	98.66 (5)
S4-Ga-N1	164.6 (1)	S4-Ga-N4	85.3 (1)	S4-Ga-N7	97.1 (1)
S7-Ga-N1	95.8 (1)	S7-Ga-N4	163.4 (1)	S7-Ga-N7	84.7 (1)
N1-Ga-N4	79.3 (1)	N1-Ga-N7	78.9 (1)	N4-Ga-N7	78.9 (1)
Ga-S1-C12	99.3 (2)	Ga-S4-C42	98.7 (2)	Ga-S7-C72	99.3 (2)
Ga-N1-C2	111.0 (3)	Ga-N4-C5	111.8 (3)	Ga-N7-C8	110.5 (3)
Ga-N1-C9	105.8 (3)	Ga-N4-C3	105.2 (3)	Ga-N7-C6	105.4 (3)
Ga-N1-C11	106.1 (3)	Ga-N4-C41	105.8 (3)	Ga-N7-C71	106.0 (3)

reaction of thiol with remaining ethylene sulfide, was minimal so long as extended reaction time was avoided. The presence of unwanted oligomers can be detected by mass spectroscopy. Purity of the crude oil may be estimated from its ^1H NMR spectrum in benzene- d_6 by comparison of the integration values found for CH_2 α to N versus values for CH_2 α to S versus that found for the thiol proton present. The crude oil is subject to slow decomposition but may be easily converted to a stable solid, its dihydrochloride salt, by crystallization from a mixture of concentrated HCl and ethanol. Both forms of the ligand, free base and dihydrochloride salt, exhibit 3-fold symmetry in solution, as determined by NMR analysis.

(B) Synthesis of Ga(TS-TACN) (2). Initial attempts to use $\text{Ga}(\text{ClO}_4)_3 \cdot 6\text{H}_2\text{O}$ as starting material did not give any isolable chelate complex. Presumably, this is due to the strong oxidizing capability of perchlorate causing the oxidation of unbound ligand, thereby destroying its ability to effectively bind Ga^{3+} . Reaction of the dihydrochloride salt of TS-TACN (**1a**) was found to be very slow. Complexation was accomplished by reaction of the free base, TS-TACN (**1**), with $\text{Ga}(\text{NO}_3)_3 \cdot 9\text{H}_2\text{O}$ in ethanol. Upon mixing, the neutral complex Ga(TS-TACN) (**2**) precipitates from the reaction mixture, but may be recrystallized from boiling dichloromethane as pale pink needles.¹² This complex has limited solubility at room temperature in polar solvents, such as methanol and dichloromethane, but is much more soluble at higher temperatures. We have observed no sensitivity of the complex toward air or moisture. In solution, the complex exhibits 3-fold symmetry, just as the other gallium(III) complexes (from TX-TACN or NOTA) that contain the trisubstituted TACN ring. However, unlike the cases of Ga(TX-TACN) and Ga(NOTA), two distinct ^{13}C resonances are observed for the TACN ring methylenes of Ga(TS-TACN). This suggests the ligand TS-TACN is more rigid when bound to Ga^{3+} than in the case of TX-TACN or NOTA, where motion in the TACN ring is able to equilibrate the ring CH_2 's.

(C) Synthesis of Ga(NOTA) (3). The ligand was prepared as reported in the literature.^{8,9} We found the complexation reaction to proceed smoothly with either $\text{Ga}(\text{NO}_3)_3 \cdot 9\text{H}_2\text{O}$ or $\text{Ga}(\text{ClO}_4)_3 \cdot 6\text{H}_2\text{O}$ as the gallium(III) source and with either the trihydrochloride salt of NOTA or the monopotassium salt of NOTA. The complexation reaction proceeds in a manner exactly analogous to that reported in the literature for iron(III).¹³ The neutral complex produced, Ga(NOTA) (**3**), may be recrystallized from water as pale pink needles.¹²

(D) Structure of Ga(TS-TACN) (2) and Ga(NOTA) (3). An ORTEP drawing of **2** is shown in Figure 4. Important bond

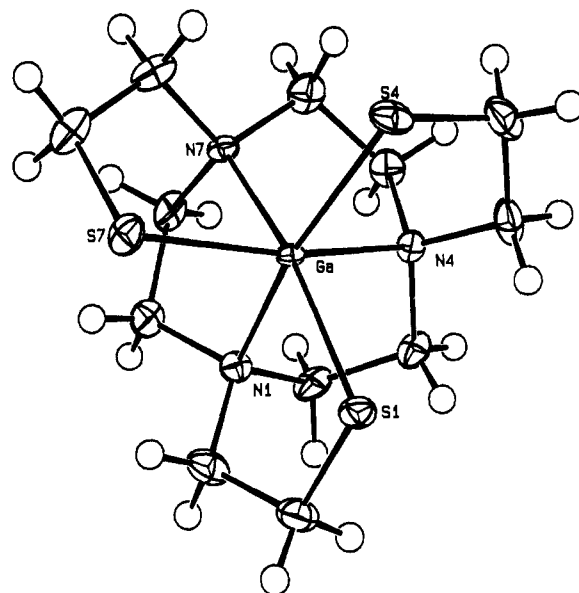

Figure 4. ORTEP drawing of Ga(TS-TACN) (**2**). Ellipsoids are drawn at the 50% probability level.

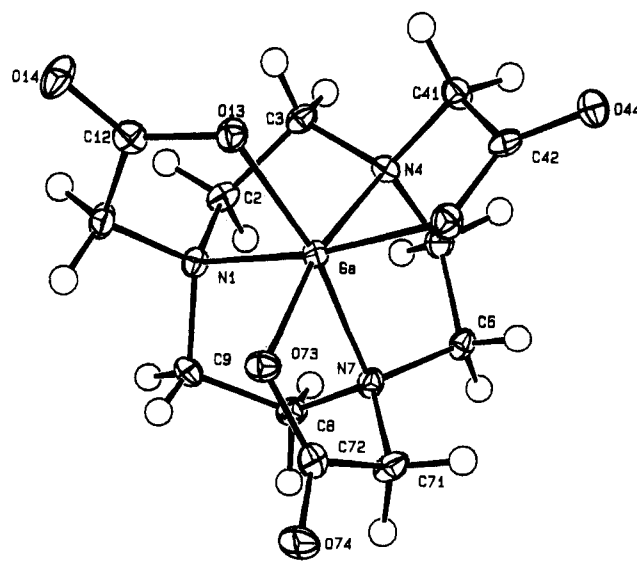

Figure 5. ORTEP drawing of Ga(NOTA) (**3**). Ellipsoids are drawn at the 50% probability level.

(12) We believe the source of the pale pink color in samples of both **2** and **3** is due to a weak metal-to-ligand charge-transfer process and not the presence of contaminants. Pale (amber) color has also been observed in the gallium complex of TX-TACN.¹

(13) Wiegardt, K.; Bossek, U.; Chaudhuri, P.; Herrmann, W.; Menke, B. C.; Weiss, J. *Inorg. Chem.* **1982**, *21*, 4308.

distances and angles are listed in Table II. An ORTEP drawing of **3** is displayed in Figure 5. Selected bond distances and angles are given in Table III. Both complexes exhibit slightly distorted

Table III. Bond Distances (Å) and Selected Bond Angles (deg) with Estimated Standard Deviations for Ga(NOTA) (3)

Bond Distances					
Ga-O13	1.928 (2)	Ga-O43	1.927 (2)	Ga-O73	1.934 (2)
Ga-N1	2.091 (3)	Ga-N4	2.079 (3)	Ga-N7	2.099 (3)
O13-C12	1.302 (4)	O43-C42	1.306 (4)	O73-C72	1.302 (4)
O14-C12	1.215 (4)	O44-C42	1.215 (4)	O74-C72	1.213 (4)
N1-C2	1.504 (4)	N4-C5	1.506 (4)	N7-C8	1.504 (4)
N1-C9	1.489 (4)	N4-C3	1.492 (4)	N7-C6	1.491 (4)
N1-C11	1.490 (4)	N4-C41	1.479 (4)	N7-C71	1.484 (4)
C11-C12	1.526 (4)	C41-C42	1.525 (5)	C71-C72	1.538 (4)
C2-C3	1.517 (4)	C5-C6	1.520 (5)	C8-C9	1.529 (4)

Bond Angles					
O13-Ga-O43	95.51 (9)	O13-Ga-O73	94.21 (9)	O13-Ga-N1	83.49 (9)
O13-Ga-N4	98.44 (9)	O13-Ga-N7	167.80 (9)	O43-Ga-O73	95.38 (9)
O43-Ga-N1	167.80 (9)	O43-Ga-N4	83.55 (9)	O43-Ga-N7	97.27 (9)
O73-Ga-N1	96.82 (9)	O73-Ga-N4	167.35 (9)	O73-Ga-N7	83.18 (9)
N1-Ga-N4	84.6 (1)	N1-Ga-N7	84.3 (1)	N4-Ga-N7	84.5 (1)
Ga-O13-C12	115.8 (2)	Ga-O43-C42	116.0 (2)	Ga-O73-C72	115.7 (2)
Ga-N1-C2	108.1 (2)	Ga-N4-C5	109.1 (2)	Ga-N7-C8	108.8 (2)
Ga-N1-C9	104.9 (2)	Ga-N4-C3	104.6 (2)	Ga-N7-C6	104.5 (2)
Ga-N1-C11	103.7 (2)	Ga-N4-C41	103.7 (2)	Ga-N7-C71	103.5 (2)
O13-C12-O14	124.6 (3)	O43-C42-O44	124.3 (3)	O73-C72-O74	124.9 (3)
O13-C12-C11	115.8 (3)	O43-C42-C41	115.1 (3)	O73-C72-C71	115.7 (3)
O14-C12-C11	119.6 (3)	O44-C42-C41	120.5 (3)	O74-C72-C71	119.4 (3)

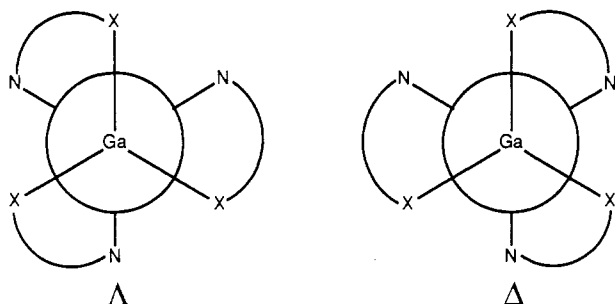
**Figure 6.** Configurational isomers resulting from the translation, or twist, of the amine substituent arms about gallium(III).

octahedral coordination of gallium(III) by a fully hexachelating ligand. The distortion may be expressed in terms of their inherent trigonal-twist angle, ϕ , where $\phi = 0^\circ$ for purely octahedral coordination and $\phi = 60^\circ$ for a purely trigonal-prismatic coordination sphere.⁹ The twist angle is 10.4 and 12.4°, respectively, for Ga(TS-TACN) and Ga(NOTA). We had expected the structure of Ga(NOTA) to closely approximate that of trigonal-prismatic Fe(NOTA),¹³ where $\phi = 34.8^\circ$, since iron(III) and gallium(III) generally display similar coordination chemistries. However, since Ga³⁺ has a greater affinity for nitrogen, resulting in shorter M-N bond lengths, than Fe³⁺, gallium(III) can rest lower in the TACN "basket", giving rise to a normal octahedral coordination geometry. In this way, Ga(NOTA) more closely resembles Cr(NOTA),¹³ where $\phi = 11.0^\circ$, and even crystallizes in the same observed unit cell. Similarly, the longer C-S and S-Ga bond lengths in Ga(TS-TACN), as compared to Ga(NOTA), result in even less steric strain, giving rise to the longer observed Ga-N bond lengths as well as a structure with even less trigonal-twist distortion.

Upon chelation, both ligands produce chiral complexes. When crystallized, both enantiomers are present in the centric ($P2_1/n$) unit cell. The source of chirality in the molecules is due to two independent phenomena: (a) the translation, or twist, of the amine substituent arms (ethane thiol or acetate, respectively) about the metal center, as configuration Δ or Λ (Figure 6), and (b) the relative puckering of the ethylenediamine-subunit chelate rings, as conformer δ or λ (Figure 7).¹⁴ Both crystal structures have the same enantiomorph pair present. This is $\Delta(\lambda\lambda\lambda)$ and $\Lambda(\delta\delta\delta)$ and is type I as described by Hancock et al.⁹ Ga(TS-TACN) has an additional element of chirality since the pendant arms of the

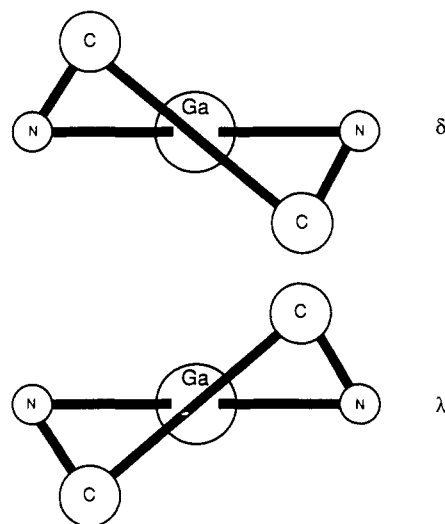
**Figure 7.** Conformational isomers resulting from puckering of ethylenediamine-gallium chelate rings.

ligand are saturated. Hence, puckering of the aminoethanethiolate-metal chelate rings may result in λ or δ conformation. The absolute configuration and conformation observed for Ga(TS-TACN) may be written as $\Delta(\lambda\lambda\lambda)_m(\delta\delta\delta)_p$ and its enantiomer $\Lambda(\delta\delta\delta)_m(\lambda\lambda\lambda)_p$, where m designates the puckering of the ethylenediamine-subunit chelate rings and p indicates that for the saturated pendant arms.

Conclusions

The ligand TS-TACNH₃ presents metal(III) ions with a very stable coordination environment. Preliminary results indicate the radioactively labeled complexes ¹¹¹In(TS-TACN) and ⁶⁸Ga(TS-TACN) are stable in vivo. However, the neutral complexes are less lipophilic than expected. We believe this is due to the presence of the facial arrangement of thiolates about the metal center. This arrangement may create a substantial dipole moment for the complex and account for the observed increase in hydrophilicity. Complete biodistribution data and labeling chemistry will be reported in a future communication. We are continuing our investigations of the syntheses of triazamacrocycle derivatives as ligands for potential radiopharmaceuticals containing ⁶⁸Ga³⁺, especially by incorporation of alkyl substituents in the macrocycle backbone or in the ethane thiol pendants, in an attempt to increase complex lipophilicity.

Acknowledgment. We thank the National Institutes of Health (Grant CA-42925) and Department of Energy (Grant

(14) (a) Cotton, F. A.; Wilkinson, G. *Advanced Inorganic Chemistry*, 5th ed.; John Wiley & Sons: New York, 1988; p 53. (b) Taylor, S. G.; Snow, M. R.; Hambley, T. W. *Aust. J. Chem.* **1983**, *36*, 2359. (c) Beattie, J. K. *Acc. Chem. Res.* **1971**, *4*, 253.

FG0287ER60512) for financial assistance. NMR spectra were obtained at the Washington University High-Resolution NMR Service Facility. This facility is funded in part by Biomedical Research Support Instrument Grant 1 S10 RR02004 and by a gift from the Monsanto Co. We thank Dr. Andrew Tyler of the Washington University Medical School for obtaining mass spectra of **1** and **2**. The Washington University Mass Spectrometry Resource is supported by a grant from the National Institutes of

Health (RR00954). The MICROVAX Computer and Enraf-Nonius CAD4 diffractometer used in the structure determinations were purchased with National Science Foundation Grant CHE-8615556.

Supplementary Material Available: Listings of positional parameters, thermal parameters, crystallographic data, and bond distances and angles for **2** and **3** (18 pages); tables of F_o and F_c for **2** and **3** (27 pages). Ordering information is given on any current masthead page.

Contribution from the Department of Chemistry,
Purdue University, West Lafayette, Indiana 47907

Reactions of the Polyhydride Complex $\text{ReH}_7(\text{PPh}_3)_2$ with Pyridinecarboxylic Acids, 2-Hydroxypyridine, 2-Hydroxy-6-methylpyridine, and Acetylacetonone. Monohydrido Complexes of Rhenium(III) and Their Oxidation to the Corresponding Rhenium(IV) Derivatives

Phillip E. Fanwick, Malee Leeaphon, and Richard A. Walton*

Received June 19, 1989

The rhenium polyhydride complex $\text{ReH}_7(\text{PPh}_3)_2$ reacts with various organic acids to give neutral monohydrido rhenium(III) complexes of stoichiometry $\text{ReH}(\text{L})_2(\text{PPh}_3)_2$, where L represents the monoanion of pyridine-2-carboxylic acid (pic), 1-isouquinolinecarboxylic acid (isoquin), pyridine-2,3-dicarboxylic acid (quin), 2-hydroxypyridine (hp), 2-hydroxy-6-methylpyridine (mhp), and acetylacetonone (acac). These complexes display a reversible couple in their cyclic voltammograms (recorded in 0.1 M *n*-Bu₄NPF₆/CH₂Cl₂), which is associated with a one-electron oxidation to their 17-electron cations. The complexes where L = pic, isoquin, mhp, and acac have been oxidized to form their paramagnetic Re(IV) congeners $[\text{ReH}(\text{L})_2(\text{PPh}_3)_2]\text{PF}_6$, using $[(\eta^5\text{-C}_5\text{H}_5)_2\text{Fe}]\text{PF}_6$ as the oxidant. These are rare examples of mononuclear Re(IV) hydride complexes; their reduction back to the neutral Re(III) precursors has been accomplished with the use of $(\eta^5\text{-C}_5\text{H}_5)_2\text{Co}$. The complexes $[\text{ReH}(\text{pic})_2(\text{PPh}_3)_2]\text{PF}_6$ (**1**), $\text{ReH}(\text{acac})_2(\text{PPh}_3)_2$ (**2**), and $[\text{ReH}(\text{acac})_2(\text{PPh}_3)_2]\text{PF}_6$ (**3**) have been structurally characterized by X-ray crystallography. Crystal data for **1** at 20 °C: space group *C2/c*, *a* = 18.730 (5) Å, *b* = 19.877 (2) Å, *c* = 24.355 (4) Å, β = 90.46 (2)°, *V* = 9066 (5) Å³, and *Z* = 8. The structure was refined to *R* = 0.036 and *R_w* = 0.041 for 3814 data with *I* > 3.0σ(*I*). Crystal data for **2** at 20 °C: space group *P1̄*, *a* = 11.892 (3) Å, *b* = 12.436 (2) Å, *c* = 15.713 (4) Å, α = 90.45 (2)°, β = 98.21 (2)°, γ = 115.53 (2)°, *V* = 2069 (2) Å³, and *Z* = 2. The structure was refined to *R* = 0.032 and *R_w* = 0.042 for 4920 data with *I* > 3σ(*I*). Crystal data for **3** at 21 °C: space group *P2₁/c*, *a* = 10.644 (3) Å, *b* = 19.803 (4) Å, *c* = 21.298 (6) Å, β = 92.48 (2)°, *V* = 4485 (4) Å³, and *Z* = 4. The structure was refined to *R* = 0.051 and *R_w* = 0.060 for 4088 data with *I* > 3.0σ(*I*). All three complexes have closely similar structures, which can be described in terms of distorted-pentagonal-bipyramidal or capped-octahedral geometries. Only in the case of **2** was the hydride ligand located in the structure analysis. The Re-H distance in **2** is 1.54 (5) Å.

Introduction

The treatment of the mononuclear polyhydride complexes $\text{ReH}_7(\text{PPh}_3)_2$ and $\text{ReH}_5(\text{PPh}_3)_2\text{L}$ (L = py, C₆H₁₁NH₂, *t*-BuNH₂) with HBF₄·Et₂O in acetonitrile or propionitrile results in the loss of H₂ and the formation of the seven-coordinate monohydrido-rhenium(III) complexes $[\text{ReH}(\text{NCR})_3\text{L}(\text{PPh}_3)_2](\text{BF}_4)_2$ (R = CH₃, C₂H₅; L = CH₃CN, C₂H₅CN, py, C₆H₁₁NH₂, *t*-BuNH₂).¹ While electrochemical measurements (cyclic voltammetry) on solutions of these complexes in 0.1 M *n*-Bu₄NPF₆/CH₂Cl₂ showed that they possess a reversible one-electron oxidation in the potential range +1.0 to +1.6 V (vs Ag/AgCl), we were not successful in isolating samples of the paramagnetic rhenium(IV) species $[\text{ReH}(\text{NCR})_3\text{L}(\text{PPh}_3)_2]^{3+}$. By reverting to organic ligands that both serve as monoprotic acids toward $\text{ReH}_7(\text{PPh}_3)_2$, with the release of H₂, and give rise to bidentate monoanionic ligands that help stabilize the resulting lower valent rhenium hydride species, we have succeeded in isolating neutral seven-coordinate monohydrido rhenium(III) complexes of the type $\text{ReH}(\text{L})_2(\text{PPh}_3)_2$, where L is the monoanion of pyridine-2-carboxylic acid (pic), 1-isouquinolinecarboxylic acid (isoquin), pyridine-2,3-dicarboxylic acid (quin), 2-hydroxypyridine (hp), 2-hydroxy-6-methylpyridine (mhp), or acetylacetonone (acac). In several instances, these complexes have been oxidized to their rhenium(IV) congeners; these

constitute rare examples of mononuclear rhenium(IV) hydride complexes.^{2,3} The synthesis and characterization of these complexes is described in this report, including details of the X-ray crystal structures of $[\text{ReH}(\text{pic})_2(\text{PPh}_3)_2]\text{PF}_6$, and the redox pair $\text{ReH}(\text{acac})_2(\text{PPh}_3)_2$ and $[\text{ReH}(\text{acac})_2(\text{PPh}_3)_2]\text{PF}_6$.

Experimental Section

Starting Materials. The polyhydride complexes $\text{ReH}_7(\text{PPh}_3)_2$, $\text{ReH}_5(\text{PPh}_3)_3$, and $\text{ReH}_5(\text{PPh}_3)_2(\text{py})$ were prepared by standard literature methods.⁴ Cobaltocene was obtained from Strem Chemicals while $[(\eta^5\text{-C}_5\text{H}_5)_2\text{Fe}]\text{PF}_6$ was prepared as described in the literature.⁵ Other reagents and solvents were obtained from commercial sources. Solvents were thoroughly deoxygenated prior to use.

Reaction Procedures. All reactions were performed under an atmosphere of dry nitrogen.

A. Reactions of $\text{ReH}_7(\text{PPh}_3)_2$ with Pyridinecarboxylic Acids. (i) $\text{ReH}(\text{pic})_2(\text{PPh}_3)_2\cdot\text{H}_2\text{O}$. A slurry of $\text{ReH}_7(\text{PPh}_3)_2$ (0.100 g, 0.14 mmol) and pyridine-2-carboxylic acid (0.034 g, 0.28 mmol) in 5 mL of ethanol was refluxed for 20 min. Diethyl ether (100 mL) was added to the cooled reaction mixture, and the dark red solution was stirred for 5 min. A red

(1) Allison, J. D.; Moehring, G. A.; Walton, R. A. *J. Chem. Soc., Dalton Trans.* 1986, 67.

(2) Conner, K. A.; Walton, R. A. In *Comprehensive Coordination Chemistry*; Wilkinson, G., Ed.; Pergamon: Oxford, England, 1987; Chapter 43, p 174.

(3) There are of course several examples of dinuclear rhenium(IV) hydrides of the type $\text{Re}_2\text{H}_8(\text{PR}_3)_4$; see: ref 2, pp 174-175.

(4) Chatt, J.; Coffey, R. S. *J. Chem. Soc. A* 1969, 1963.

(5) Fanwick, P. E.; Harwood, W. S.; Walton, R. A. *Inorg. Chim. Acta* 1986, 122, 7.