

# Oxidative Addition of Disulfides to the Complex $W(CO)_3(phen)(EtCN)$ . Synthesis, Structure, and Reactivity of $W(CO)_2(phen)(SR)_2$ ( $R = Ph, Me, CH_2Ph, ^tBu$ ; phen = 1,10-Phenanthroline) Coordinatively Unsaturated Complexes of Tungsten(II) That Reversibly Bind CO and Other Ligands

Russell F. Lang, Telvin D. Ju, Gabor Kiss, Carl D. Hoff,\* Jeffrey C. Bryan, and Gregory J. Kubas\*

Department of Chemistry, University of Miami, Coral Gables, Florida 33124, and Los Alamos National Laboratory, University of California, Los Alamos, New Mexico 87545

Received October 14, 1993\*

The complex  $W(CO)_3(phen)(EtCN)$  undergoes oxidative addition with disulfides forming the formally 16-electron complexes  $W(CO)_2(phen)(SR)_2$  ( $R = Ph, ^tBu, Me, benzyl$ ). The reactions proceed through intermediates identified spectroscopically as the coordinated disulfide complexes. The rate of oxidative addition of coordinated disulfides is in the order  $^tBuSSBu \ll MeSSMe < PhCH_2SSCH_2Ph < PhSSPh$ . The complexes  $W(CO)_2(phen)(SR)_2$  undergo ligand addition, ligand substitution, and thiol/thiolate exchange reactions. Variable-temperature equilibrium studies yielded thermodynamic parameters for binding of CO to  $W(CO)_2(phen)(SR)_2$ :  $R = Ph, \Delta H = -7.2 \pm 0.5$  kcal/mol,  $\Delta S = -29 \pm 3.5$  cal/(mol deg);  $R = ^tBu, \Delta H = -9.5 \pm 0.5$  kcal/mol,  $\Delta S = -41 \pm 3.5$  cal/(mol deg). Reaction with trimethylphosphine yields an equilibrium mixture of the 18-electron adduct  $W(CO)_2(phen)(PMe_3)(SPh)_2$  as well as the 16-electron monocarbonyl complex  $W(CO)(phen)(PMe_3)(SPh)_2$ . Addition of trimethyl phosphite yields only  $W(CO)(phen)(P(OMe)_3)(SPh)_2$ . Pyridine, propionitrile, hydrogen, and THF do not bind to the W(II) complexes. Reaction of  $W(CO)_2(phen)(S^tBu)_2$  with 1 equiv of thiophenol yields  $W(CO)_2(phen)(S^tBu)(SPh)$ , which reacts with additional thiophenol to yield  $W(CO)_2(phen)(SPh)_2$ . Reaction with excess hydrogen sulfide yields  $W(CO)_2(phen)(SH)_2$ , which reacts further with thiophenol to yield  $W(CO)_2(phen)(SPh)_2$ . Crystal structures are reported for  $W(CO)_2(phen)(SPh)_2$  and  $W(CO)(phen)(P(OMe)_3)(SPh)_2$ .

## Introduction

The oxidative addition of sulfur ligands, particularly disulfides and thiols, is an important reaction for transition metals. It has been widely studied for the group VI metals due to biochemical relevance<sup>1,2</sup> as well as utilization of molybdenum in hydrodesulfurization.<sup>3,4</sup> Group VI/sulfur systems show a range of reactivity which depends on the metal, its oxidation state, ligand environment, and the nature of the sulfur compound and its substituents. The factors controlling oxidative addition of a specific organosulfur compound to a metal complex remain to be delineated.

Otsuka, Higuchi, and co-workers<sup>5</sup> showed that a Mo(IV) thiolate could be readily reduced by carbon monoxide under pressure:

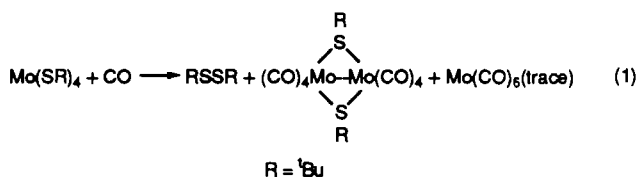

From a thermodynamic point of view such a reductive elimination might seem unexpected, since most low-valent organometallic complexes are thermodynamically unstable with respect to oxidation.

\* To whom correspondence should be addressed: C.D.H., University of Miami; G.J.K., Los Alamos National Laboratory.

- \* Abstract published in *Advance ACS Abstracts*, July 15, 1994.
- (1) *Molybdenum Enzymes, Cofactors, and Model Systems*; Stiefel, E. I., Coucouvanis, D., Newton, W. E., Eds.; ACS Symposium Series 535; American Chemical Society: Washington, DC, 1993.
  - (2) *Molybdenum Enzymes*; Spiro, T. G., Ed.; Wiley: New York, 1985.
  - (3) Riaz, U.; Curnow, O.; Curtis, M. D. *J. Am. Chem. Soc.* **1991**, *113*, 1416.
  - (4) Calhorda, M. J.; Hoffmann, R.; Friend, C. M. *J. Am. Chem. Soc.* **1990**, *112*, 50.
  - (5) Kamata, K.; Yoshida, T.; Otsuka, S.; Hirotsu, K.; Higuchi, T. *J. Am. Chem. Soc.* **1981**, *103*, 3572–3574.

In a series of papers studying fluxionality via NMR techniques, Abel and co-workers<sup>6</sup> reported sulfur migrations such as those shown as follows:

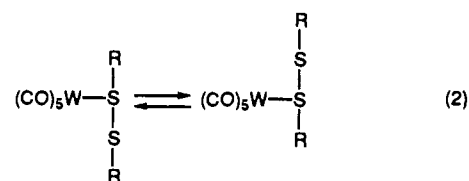

No evidence was found for oxidative addition in these systems. Careful chemical and electrochemical studies by Darensbourg, Krusic, and co-workers<sup>7</sup> showed oxidation of the anionic complexes in (3), again without further oxidation of the metal by disulfide.

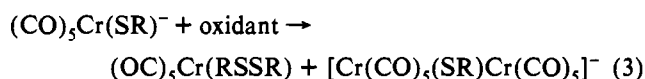

This is in contrast to work by James and co-workers on a ruthenium carbonyl phosphine complex<sup>8</sup> which underwent oxidative addition as shown in (4). Thiolate hydride as well as dithiolate complexes

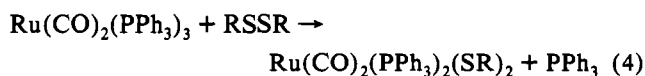

have been isolated in oxidative addition reactions to low-valent

- (6) Abel, E. W.; Moss, I.; Orrell, K. G.; Sik, V.; Stephenson, D. *J. Chem. Soc., Chem. Commun.* **1986**, 1724–1725.
- (7) Springs, J.; Janzen, C. P.; Darensbourg, M. Y.; Calabrese, J. C.; Krusic, P. J.; Verpeaux, J. N.; Amatore, C. *J. Am. Chem. Soc.* **1990**, *112*, 5789–5797.
- (8) Jessop, P. G.; Rettig, S. J.; Lee, C. L.; James, B. R. *Inorg. Chem.* **1991**, *30*, 4617–4627.

group VI complexes with more basic phosphine ligands:<sup>9</sup>

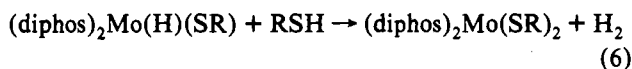
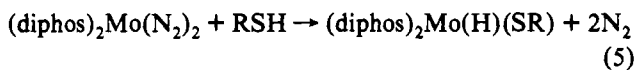

Richards and Morris<sup>10</sup> have studied ligand-induced reductive elimination of thiols from Mo(IV) complexes.

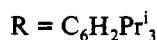
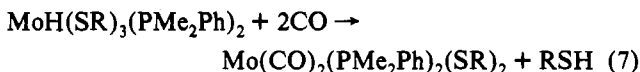

Mo(II) complexes have been recently obtained by ligand substitution on  $\text{MoCl}_2(\text{CO})_4$ .<sup>11</sup> Stieffel and co-workers<sup>12</sup> have observed the interesting reaction shown in (8). In this reaction, treatment of Mo(VI) with disulfides (normally an oxidizing agent) results in internal redox in which the metal itself is actually reduced.

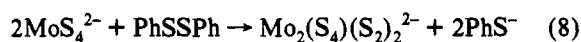

The work described above shows that there are a number of ways that disulfides can interact with metal complexes. There is little thermodynamic data regarding disulfide/metal interactions.<sup>13</sup> As part of our work on the thermochemistry of group VI complexes,<sup>14</sup> we had begun investigation of the heats of ligand exchange for the complexes shown in (9). A particular area of

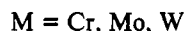

interest is the determination of metal–sulfur bond strengths for complexes capable of further reaction with species such as thiols, disulfides, and sulfur dioxide. This paper describes synthetic, structural, and reactivity studies that provide a basis for kinetic and thermodynamic studies in progress.

## Experimental Section

All manipulations were carried out using standard Schlenk techniques under an atmosphere of argon or in a Vacuum Atmospheres glovebox. Tungsten hexacarbonyl was obtained from Strem Chemical and used without further purification. Tetrahydrofuran and toluene were purified by distillation from sodium benzophenone ketyl under argon into flame-dried glassware. Propionitrile and methylene chloride were purified by heating under reflux followed by distillation from  $\text{P}_2\text{O}_5$ . Heptane, spectrophotometric grade, was degassed prior to use. Diphenyl disulfide was recrystallized from ethyl alcohol/diethyl ether prior to use. Carbon monoxide, 99.995%, and hydrogen sulfide, 99.5%, were obtained from Matheson gas and used without further purification. Organosulfur compounds were obtained from Aldrich Chemical. Infrared spectra (data in  $\text{cm}^{-1}$ ) were run on a Perkin-Elmer 1850 FTIR spectrophotometer in  $\text{CaF}_2$  solution cells. Equilibrium data under pressure were obtained in a specially constructed high-pressure cell with Ge windows using

(9) Henderson, R. A.; Hughes, D. L.; Richards, R. L.; Shortman, C. A. *J. Chem. Soc., Dalton Trans.* **1987**, 1115–1121.

(10) Burrow, T. E.; Lough, A. J.; Morris, R. H.; Hills, A.; Richards, R. L. *J. Chem. Soc., Dalton Trans.* **1991**, 2519.

(11) Bishop, P. T.; Dilworth, J. R.; Nicholson, T.; Zubieta, J. *J. Chem. Soc., Dalton Trans.* **1991**, 385–392.

(12) Coyle, C. L.; Harmer, M. A.; George, G. N.; Daage, M.; Stiefel, E. I. *Inorg. Chem.* **1990**, *29*, 14–19.

(13) For an excellent treatment and list of available metal–sulfur bond dissociation energies see: Simoes, J. A. M.; Beauchamp, J. L. *Chem. Rev.* **1990**, *90*, 629.

(14) Hoff, C. D. *Prog. Inorg. Chem.* **1992**, *40*, 503–561 and references therein.

procedures described previously.<sup>15</sup> NMR spectra were obtained on a Varian VXR 400-MHz spectrometer. All NMR data reported are  $^1\text{H}$  in ppm relative to tetramethylsilane at a temperature of 25 °C unless stated otherwise. X-ray diffraction studies were performed at Los Alamos using a Siemens R3m/V diffractometer.

**Preparation of  $\text{W}(\text{CO})_3(\text{phen})(\text{EtCN})$ .** In a 500-mL Schlenk tube fitted with a reflux condenser and exit bubbler, 6 g of  $\text{W}(\text{CO})_6$ , 3.6 g of 1,10 phenanthroline (phen), and 200 mL of EtCN freshly distilled from  $\text{P}_2\text{O}_5$  were heated under reflux for 36 h. At the end of that time, the solution had turned the characteristic violet color of the product. It was cooled under argon and stored in the freezer for about 1 h. The precipitate of spectroscopically pure product (IR bands at 1897 and 1787  $\text{cm}^{-1}$  in EtCN) (NMR (in  $\text{CD}_2\text{Cl}_2$ ) signals: phen protons (8H), 9.54 doublet, 8.45 doublet, 7.97 singlet, 7.74 doublet of doublets; EtCN protons (5H), 2.1 quartet, 0.8 triplet) was collected on a frit to yield 5.5 g of fine black crystalline product in 64% yield. The filtrate can be recycled for use in other preparations.

**Reaction of  $\text{W}(\text{CO})_3(\text{phen})(\text{EtCN})$  and RSSR (R = Phenyl, Methyl, Benzyl).** **a. Excess PhSSPh.** In the glovebox, 4 g of  $\text{W}(\text{CO})_3(\text{phen})(\text{EtCN})$  was dissolved in 250 mL of methylene chloride in a 500-mL Schlenk tube. In a separate flask, 30 g of PhSSPh (17 equiv) was dissolved in 100 mL of  $\text{CH}_2\text{Cl}_2$ . The disulfide solution was added to the complex and the flask evacuated. The solution was stirred at 30–35 °C with continuous evacuation to remove CO given off during the reaction. After about 1 h, the volume of solvent was reduced to about 100 mL. The solution was filtered, 150 mL of heptane was added, and solvent was slowly evaporated until crystals began to appear. It was then cooled in the freezer for 2–3 h. The crystalline product  $\text{W}(\text{CO})_2(\text{phen})(\text{SPh})_2$  was collected on a frit and washed with heptane, 4.1 g, 80% yield. The complex shows IR bands at 1944 (vs) and 1847 (s) in  $\text{CH}_2\text{Cl}_2$ , and NMR signals in  $\text{CD}_2\text{Cl}_2$  as follows: phen (8H) protons, 8.46 (d), 8.24 (d), 7.65 (dd), 7.59 (s);  $\text{S}-\text{C}_6\text{H}_5$  (12H) protons, 6.22, 6.11, 5.68 (broad, unresolved).

**b. 1/1 PhSSPh/ $\text{W}(\text{CO})_3(\text{phen})(\text{EtCN})$  Ratio.** In the glovebox a 10.0-mL volumetric flask was loaded with 0.0702 g (0.14 mmol) of  $\text{W}(\text{CO})_3(\text{phen})(\text{EtCN})$ , 0.0156 g (0.072 mmol) of PhSSPh, and 10 mL of purified methylene chloride. The flask was stoppered, shaken, and left in the glovebox for 4 h. At that time an aliquot was withdrawn and analyzed via FTIR spectroscopy. This indicated that the complexes  $\text{W}(\text{CO})_4(\text{phen})$  (IR peaks in  $\text{CH}_2\text{Cl}_2$  at 2008 (m), 1893 (s), 1873 (m,sh), and 1827 (m)) and  $\text{W}(\text{CO})_2(\text{phen})(\text{SPh})_2$  were formed in nearly equimolar amounts and only traces of other materials were detected.

**c. Spectroscopic Detection of  $\text{W}(\text{CO})_3(\text{phen})(\text{PhSSPh})$ .** Two solutions were prepared in the glovebox; one contained 0.08 g of  $\text{W}(\text{CO})_3(\text{phen})(\text{EtCN})$  in 15 mL of  $\text{CH}_2\text{Cl}_2$  and the other 0.7 g (20 equiv) of recrystallized PhSSPh in 10 mL of  $\text{CH}_2\text{Cl}_2$ . The solutions were mixed, and an FTIR spectrum was measured within 1 min. In addition to bands assignable to  $\text{W}(\text{CO})_2(\text{phen})(\text{SPh})_2$  and  $\text{W}(\text{CO})_4(\text{phen})$ , and a small amount of  $\text{W}(\text{CO})_3(\text{phen})(\text{EtCN})$ , two new peaks at approximately 1910 and 1811  $\text{cm}^{-1}$  were tentatively assigned to be  $\text{W}(\text{CO})_3(\text{phen})(\text{PhSSPh})$  on the basis of peak shape and position as well as comparison to spectral data for  $\text{W}(\text{CO})_3(\text{phen})(\text{Ph}_2\text{S})$ .

**d. Preparative Reaction with Other Disulfides, RSSR (R = Methyl, Benzyl).** These reactions were carried out in strictly analogous fashion to those described above for PhSSPh. Infrared data for the complexes are collected in Table 1.  $^1\text{H}$  NMR data are collected in Table 2.

**e. Detection of Intermediate Bound  $\text{W}(\text{CO})_3(\text{phen})(\text{MeSSMe})$ .** In the first reaction (10% MeSSMe/ $\text{CH}_2\text{Cl}_2$ ), in the glovebox a solution was prepared from 0.08 g of  $\text{W}(\text{CO})_3(\text{phen})(\text{EtCN})$  and 15 mL of  $\text{CH}_2\text{Cl}_2$ . The solution was filtered and 10 mL of it transferred to the high-pressure FTIR cell/reactor.<sup>15</sup> The pressure fitting was replaced by a septum and the apparatus removed from the glovebox. Dimethyl disulfide, 1 mL, was added by syringe and the solution shaken. A series of infrared spectra showed nearly complete disappearance of peaks at 1899 and 1783  $\text{cm}^{-1}$  due to  $\text{W}(\text{CO})_3(\text{phen})(\text{EtCN})$  within 35 s of mixing. Appearance of two new peaks at 1906 and 1793  $\text{cm}^{-1}$ , assigned to  $\text{W}(\text{CO})_3(\text{phen})(\text{MeSSMe})$ , appear and then decrease in intensity as peaks due to  $\text{W}(\text{CO})_2(\text{phen})(\text{SMe})_2$  at 1936 and 1832  $\text{cm}^{-1}$  increase. The final spectrum shows peaks due only to  $\text{W}(\text{CO})_2(\text{phen})(\text{SMe})_2$  and  $\text{W}(\text{CO})_4(\text{phen})$ . In a second reaction (0.5% MeSSMe/ $\text{CH}_2\text{Cl}_2$ ), performed in an analogous way, a solution was prepared from 0.119 g of  $\text{W}(\text{CO})_3(\text{phen})(\text{EtCN})$  in 25 mL of  $\text{CH}_2\text{Cl}_2$ , and 0.115 mL of MeSSMe was added. The solution was filtered into the FTIR cell, and the apparatus was closed and removed from the glovebox. The first spectrum was obtained after 9 min of reaction,

(15) Watkins, W. C.; Jaeger, T.; Kidd, C. E.; Fortier, S.; Baird, M. C.; Kiss, G.; Roper, G. C.; Hoff, C. D. *J. Am. Chem. Soc.* **1992**, *114*, 907.

**Table 1.** Infrared Data for Complexes

complex	solvent	$\nu(\text{CO}), \text{cm}^{-1}$
W(CO) <sub>3</sub> (phen)(EtCN)	THF	1897 (vs), 1787 (s)
W(CO) <sub>3</sub> (phen)(EtCN)	EtCN	1898 (vs), 1785 (s)
W(CO) <sub>3</sub> (phen)(EtCN)	CH <sub>2</sub> Cl <sub>2</sub>	1898 (vs), 1785 (s)
W(CO) <sub>3</sub> (phen)( <sup>t</sup> BuSSBu <sup>t</sup> )	CH <sub>2</sub> Cl <sub>2</sub>	1901 (vs), 1787 (s)
W(CO) <sub>3</sub> (phen)(PhCH <sub>2</sub> SSCH <sub>2</sub> Ph)	CH <sub>2</sub> Cl <sub>2</sub>	1904 (vs), 1790 (s)
W(CO) <sub>3</sub> (phen)(MeSSMe)	CH <sub>2</sub> Cl <sub>2</sub>	1906 (vs), 1791 (s)
W(CO) <sub>3</sub> (phen)(PhSSPh)	CH <sub>2</sub> Cl <sub>2</sub>	1910 (vs), 1811 (s)
W(CO) <sub>4</sub> (phen)	CH <sub>2</sub> Cl <sub>2</sub>	2008 (m), 1893 (s), 1873 (m), 1827 (m)
W(CO) <sub>2</sub> (phen)(SPh) <sub>2</sub>	CH <sub>2</sub> Cl <sub>2</sub>	1944 (vs), 1847 (s)
W(CO) <sub>2</sub> (phen)(SPh) <sub>2</sub>	THF	1945 (vs), 1852 (s)
W(CO) <sub>2</sub> (phen)(SPh) <sub>2</sub>	toluene	1949 (vs), 1860 (s)
W(CO) <sub>3</sub> (phen)(SPh) <sub>2</sub>	THF	1986 (vs), 1922 (w), 1885 (s)
W(CO)(PMe <sub>3</sub> )(phen)(SPh) <sub>2</sub>	THF	1792 (vs)
W(CO) <sub>2</sub> (PMe <sub>3</sub> )(phen)(SPh) <sub>2</sub>	THF	1916 (vs), 1823 (vs)
W(CO)(P(OMe) <sub>3</sub> )(phen)(SPh) <sub>2</sub>	THF	1812 (vs)
W(CO) <sub>2</sub> (phen)(SMe) <sub>2</sub>	CH <sub>2</sub> Cl <sub>2</sub>	1937 (vs), 1835 (s)
W(CO) <sub>3</sub> (phen)(SMe) <sub>2</sub>	CH <sub>2</sub> Cl <sub>2</sub>	1985 (vs), 1879 (s)
W(CO) <sub>2</sub> (phen)(SCH <sub>2</sub> Ph) <sub>2</sub>	CH <sub>2</sub> Cl <sub>2</sub>	1940 (vs), 1838 (s)
W(CO) <sub>3</sub> (phen)(SCH <sub>2</sub> Ph) <sub>2</sub>	CH <sub>2</sub> Cl <sub>2</sub>	1987 (vs), 1908 (sh), 1885 (s, br)
W(CO) <sub>2</sub> (phen)( <sup>t</sup> BuS) <sub>2</sub>	THF	1936 (vs), 1823 (s)
W(CO) <sub>3</sub> (phen)( <sup>t</sup> BuS) <sub>2</sub>	THF	1960 (vs), 1850 (s)
W(CO)(P(OMe) <sub>3</sub> )(phen)( <sup>t</sup> BuS) <sub>2</sub>	THF	1815 (s)
W(CO) <sub>2</sub> (phen)(SH) <sub>2</sub>	THF	1948 (vs), 1845 (s)
W(CO) <sub>2</sub> (bipy)(SPh) <sub>2</sub>	THF	1944 (vs), 1852 (s)
W(CO) <sub>3</sub> (bipy)(SPh) <sub>2</sub>	THF	1988 (s), 1920 (w), 1887 (s)

**Table 2.** NMR Data for Selected Complexes

complex	phenanthroline ligand	other
W(CO) <sub>3</sub> (phen)(EtCN)	9.54 (d) 8.45 (d) 7.97 (s) 7.74 (dd)	EtCN 2.1 (q) 0.8 (t)
W(CO) <sub>4</sub> (phen)	9.56 (d) 8.52 (d) 8.02 (s) 7.79 (dd)	
W(CO) <sub>2</sub> (phen)(SPh) <sub>2</sub>	8.46 (d) 8.24 (d) 7.65 (dd) 7.59 (s)	SC <sub>6</sub> H <sub>5</sub> 6.22 (br) 6.11 (br) 5.68 (br)
W(CO)(P(OMe) <sub>3</sub> )- (phen)(SPh) <sub>2</sub>	8.81 (d) 8.62 (d) 8.30 (d) 7.84 (d) 7.61 (d) 7.42 (d) 7.64 (dd) 7.38 (dd)	SC <sub>6</sub> H <sub>5</sub> 6.19 (br) 6.10 (br) 5.64 (br)
W(CO) <sub>2</sub> (phen)(SMe) <sub>2</sub>	8.57 (d) (set of two overlapping) 8.17 (s) 7.77 (dd)	P(OCH <sub>3</sub> ) <sub>3</sub> 3.96 J- <sup>31</sup> P-H = 12 Hz SMe 1.96 (s)
W(CO) <sub>2</sub> (phen)( <sup>t</sup> BuS) <sub>2</sub>	8.51 (set of two) (d) 8.11 (s) 7.75 (br)	S- <sup>t</sup> Bu 1.5 (s)
W(CO) <sub>2</sub> (phen)- (SCH <sub>2</sub> C <sub>6</sub> H <sub>5</sub> ) <sub>2</sub>	8.61 (br) 8.52 (d) 8.12 (s) 7.74 (dd)	CH <sub>2</sub> -C <sub>6</sub> H <sub>5</sub> 3.50 (br) CH <sub>2</sub> -C <sub>6</sub> H <sub>5</sub> 7.07 (tr) 7.02 (multi) 6.90 (br)

and a series of infrared spectra were measured over a 1-h period. The products W(CO)<sub>2</sub>(phen)(SMe)<sub>2</sub> and W(CO)<sub>4</sub>(phen) increase smoothly over this time period; peaks at 1906, 1899, and 1888 and a broad peak centered at 1783 cm<sup>-1</sup> decreased in intensity. The peaks at 1906 and 1899 cm<sup>-1</sup> are assigned to W(CO)<sub>3</sub>(phen)(EtCN) and W(CO)<sub>3</sub>(phen)(MeSSMe), respectively. The peak at 1888 cm<sup>-1</sup> is assigned to [W(CO)<sub>2</sub>(phen)(SMe)<sub>2</sub>][W(CO)<sub>3</sub>(phen)] and confirmed by separate experiments

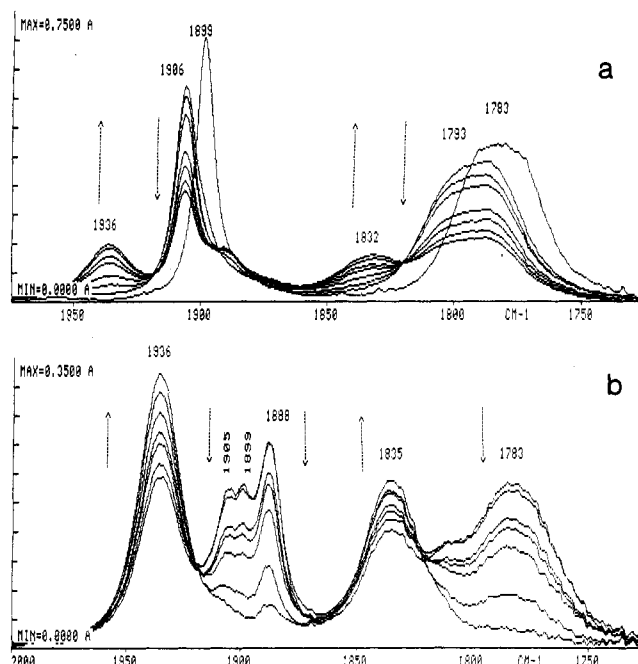

**Figure 1.** FTIR studies of reaction of MeSSMe at two different concentrations with W(CO)<sub>3</sub>(phen)(EtCN). In (a) (top), run in 10% MeSSMe/CH<sub>2</sub>Cl<sub>2</sub>, conversion of W(CO)<sub>3</sub>(phen)(EtCN) (1899, 1783 cm<sup>-1</sup>) to W(CO)<sub>3</sub>(phen)(MeSSMe) (1906, 1793 cm<sup>-1</sup>) occurs rapidly upon mixing the solutions. The coordinated disulfide complex then smoothly decays to W(CO)<sub>2</sub>(phen)(SMe)<sub>2</sub> (1936, 1832 cm<sup>-1</sup>). Spectra were run approximately every 1 min. In (b) (bottom), run in 0.5% MeSSMe/CH<sub>2</sub>Cl<sub>2</sub>, additional bands at 1899 and 1888 appear due to presence of equilibrium amounts of the starting nitrile complex and also the dimeric complex [W(CO)<sub>2</sub>(phen)(SMe)<sub>2</sub>][W(CO)<sub>3</sub>(phen)]. Spectra were run approximately every 3 min. See text for additional details.

in which addition of W(CO)<sub>2</sub>(phen)(SMe)<sub>2</sub> to W(CO)<sub>3</sub>(phen)(EtCN) resulted in generation of the same A<sub>1</sub> band at 1888 cm<sup>-1</sup>. Spectra for both these reactions are shown in Figure 1.

**Growth of Crystals for Structure of W(CO)<sub>2</sub>(phen)(SPh)<sub>2</sub>.** The solid complex was dissolved in toluene and the solution filtered into a 25-mL Erlenmeyer flask. Slow evaporation of the toluene, over a 6-week period, produced a crop of large crystals. Cleavage of one of the larger crystals produced the final specimen which was mounted for study.

**Equilibrium Binding of CO by W(CO)<sub>2</sub>(phen)(SR)<sub>2</sub>.** A solution of 0.2403 g of W(CO)<sub>2</sub>(phen)(SPh)<sub>2</sub> was prepared in a volumetric flask in 25.0 mL of THF. The solution was loaded into the high-pressure controlled temperature cell, taken out of the glovebox, filled, purged, and refilled with 250 psi of carbon monoxide. Equilibrium spectral data were obtained over the range -3 to +40 °C. The solutions showed no signs of decomposition, and spectral changes were fully reversible and reproducible in this region. Stock solutions of W(CO)<sub>2</sub>(phen)(SPh)<sub>2</sub> in THF in the absence of CO were used to determine the extinction coefficient of the starting material as a function of temperature. Similar techniques were used for qualitative observations of binding of W(CO)<sub>2</sub>(phen)(SR)<sub>2</sub> and quantitative measurements for W(CO)<sub>2</sub>(phen)(S<sup>t</sup>Bu)<sub>2</sub>.

**Reaction of W(CO)<sub>3</sub>(phen)(EtCN) and W(CO)<sub>2</sub>(phen)(SPh)<sub>2</sub>.** In the glovebox, 0.5 g (1 mmol) of W(CO)<sub>3</sub>(phen)(EtCN) and 0.63 g (1 mmol) of W(CO)<sub>2</sub>(phen)(SPh)<sub>2</sub> were added to a 250-mL Schlenk tube containing 100 mL of tetrahydrofuran. The reaction mixture was stirred under argon for 6–7 h. During this time a copious amount of precipitate formed, and infrared analysis of the mother liquor indicated decrease in absorbance of bands due to the starting materials which corresponded to a 1 to 1 ratio of reactants. The solution was a light black. The flask was stored in the freezer and the solid collected on a frit, 0.8 g, 76% yield based on the formulation of the complex as [W(CO)<sub>3</sub>(phen)][W(CO)<sub>2</sub>(phen)(SPh)<sub>2</sub>]. A Nujol spectrum of the solid showed bands at 1949, 1881, 1846, and 1778 cm<sup>-1</sup>. Treatment with CO at 250 psi showed complete conversion to W(CO)<sub>4</sub>(phen) and an equilibrium mixture of W(CO)<sub>3</sub>(phen)(SPh)<sub>2</sub> and W(CO)<sub>2</sub>(phen)(SPh)<sub>2</sub>.

**Reaction of W(CO)<sub>2</sub>(phen)(SPh)<sub>2</sub> with P(OMe)<sub>3</sub>.** To a 250-mL Schlenk tube containing a slurry of 0.3 g of W(CO)<sub>2</sub>(phen)(SPh)<sub>2</sub> and 100 mL of toluene was added 1.1 mL of P(OMe)<sub>3</sub>. The mixture was stirred magnetically and placed in a water bath at 44 °C overnight.

Periodically samples were withdrawn via syringe, and their infrared spectra showed slow emergence of a single band at 1817  $\text{cm}^{-1}$ . The reaction was cooled, and 0.22 g (64% yield) of a black crystalline precipitate of  $\text{W}(\text{CO})_2(\text{phen})(\text{P}(\text{OMe})_3)(\text{SPh})_2$  was collected. The material was spectroscopically pure, showing  $\nu(\text{CO})$  of 1813  $\text{cm}^{-1}$  in THF solution. The NMR spectrum in  $\text{CD}_2\text{Cl}_2$  showed signals as follows: phen protons (8H), 8.81 (d), 8.62 (d), 8.30 (d), 7.84 (d), 7.61 (d), 7.42 (d), 7.64 (dd), 7.38 (dd);  $\text{SC}_6\text{H}_5$  (10H), 6.19, 6.10, 5.64;  $\text{P}(\text{OCH}_3)_3$  (9H), 3.96 (d),  $J_{\text{P-H}} = 12$  Hz.

**Crystal Growth for  $\text{W}(\text{CO})_2(\text{phen})(\text{P}(\text{OMe})_3)(\text{SPh})_2$ .** A saturated solution of  $\text{W}(\text{CO})_2(\text{phen})(\text{P}(\text{OMe})_3)(\text{SPh})_2$  in THF was placed in a small open vial. This vial was placed inside a second larger vial containing hexane which slowly diffused into the THF solution causing precipitation of the crystalline complex. From the crop of crystals formed, one was selected and mounted for study.

**Reaction of  $\text{W}(\text{CO})_2(\text{phen})(\text{SPh})_2$  with  $\text{PMe}_3$ .** A slurry of 0.3 g of  $\text{W}(\text{CO})_2(\text{phen})(\text{SPh})_2$  in about 50 mL of toluene was prepared. To this was added 1 mL of  $\text{PMe}_3$  under argon. The solution turned red instantly, and all solid dissolved. The infrared spectrum indicated initial formation of a dicarbonyl product with bands at 1916 (vs) and 1823 (vs) formulated as  $\text{W}(\text{CO})_2(\text{Phen})(\text{PMe}_3)(\text{SPh})_2$ . Continued evacuation over a period of hours resulted in the disappearance of these bands and emergence of a single band at 1792 (vs) formulated as  $\text{W}(\text{CO})(\text{phen})(\text{PMe}_3)(\text{SPh})_2$ .

**Carbonylation Reactions of  $\text{W}(\text{CO})(\text{phen})(\text{PMe}_3)(\text{SPh})_2$ .** A solution of  $\text{W}(\text{CO})(\text{phen})(\text{PMe}_3)(\text{SPh})_2$  in THF containing a 10-fold excess of free  $\text{PMe}_3$  was loaded into the high-pressure FTIR cell and filled with 250 psi of CO. The first spectrum obtained showed complete disappearance of bands due to  $\text{W}(\text{CO})(\text{phen})(\text{PMe}_3)(\text{SPh})_2$  and emergence of bands attributed to  $\text{W}(\text{CO})_2(\text{phen})(\text{PMe}_3)(\text{SPh})_2$ . In a slower secondary reaction, the phosphine ligand was partially displaced forming equilibrium amounts of  $\text{W}(\text{CO})_2(\text{phen})(\text{SPh})_2$  and  $\text{W}(\text{CO})_3(\text{phen})(\text{SPh})_2$  in addition to residual amounts of the starting complex  $\text{W}(\text{CO})_2(\text{phen})(\text{PMe}_3)(\text{SPh})_2$ . After 20 min, no further changes were seen in the spectrum.

**Reaction of  $\text{W}(\text{CO})_3(\text{phen})(\text{EtCN})$  and  $^t\text{BuSS}^t\text{Bu}$ .** Approximately 3.0 g of  $\text{W}(\text{CO})_3(\text{phen})(\text{EtCN})$  was weighed into a 500-mL Schlenk tube. A separate solution of 8 mL of  $^t\text{BuSS}^t\text{Bu}$  in 200 mL of  $\text{CH}_2\text{Cl}_2$  was added to this flask, and the solution was stirred at room temperature under vacuum. Infrared spectra run shortly after mixing the two reagents showed two bands at 1901 (vs) and 1787 (s, br)  $\text{cm}^{-1}$ , assigned to a mixture of the starting nitrile complex  $\text{W}(\text{CO})_3(\text{phen})(\text{EtCN})$  as well as the  $\eta^1$ -disulfide complex  $\text{W}(\text{CO})_3(\text{phen})(^t\text{BuSS}^t\text{Bu})$ , by analogy to the molybdenum complex which is stable.<sup>16</sup> Additional evidence that a disulfide complex is formed, aside from the small but definite shift in infrared peaks, is the stability of the solution itself. In the absence of added ligand, the parent nitrile complex slowly decomposes in methylene chloride. The oxidative addition reaction is slow for  $^t\text{BuSS}^t\text{Bu}$ , but there is little attendant decomposition in this reaction. Over a 12-h period the flask was purged alternately with argon/vacuum to remove any CO evolved during the course of the reaction. After the reaction was complete as judged by FTIR it was filtered to remove small amounts of black solid formed during the reaction. The solution was evaporated to dryness to remove solvent and unreacted disulfide. The residue was redissolved in 150–200 mL of  $\text{CH}_2\text{Cl}_2$  and an additional 50–100 mL of heptane added to the flask. Slow evacuation concentrated the solution, and a dark purple solid  $\text{W}(\text{CO})_2(\text{phen})(\text{S}^t\text{Bu})_2$  was precipitated from the green solution. After approximately half the solvent was removed the first crop was isolated on a filter—1.5 g. A second crop was obtained by further concentration of the mother liquor—0.5 g for a combined yield of 2.0 g (56% yield) of a dark purple solid that dissolves readily to give deep green solutions. Infrared data in THF show absorbances at 1936 (vs) and 1823 (s), and NMR signals in  $\text{CD}_2\text{Cl}_2$  are as follows: phen protons (8H), 8.51 (two overlapping doublets), 8.11 (s), 7.75 (broad, unresolved);  $\text{S}^t\text{Bu}$  protons (18H), 1.5 (s).

**Reaction of  $\text{W}(\text{CO})_2(\text{phen})(\text{S}^t\text{Bu})_2$  and Thiophenol.** In a test tube in the glovebox, 0.06 g of  $\text{W}(\text{CO})_2(\text{phen})(\text{S}^t\text{Bu})_2$  was dissolved in 5 mL of THF. Addition of 0.09 mL of HSPH resulted in rapid color change from green to red-brown. The infrared spectrum taken 5 min after mixing showed complete conversion to  $\text{W}(\text{CO})_2(\text{phen})(\text{SPh})_2$ . In a second reaction,  $\text{W}(\text{CO})_2(\text{phen})(\text{S}^t\text{Bu})_2$  was reacted with approximately 1 equiv of thiophenol. The infrared spectrum showed a broadening of the band near 1940  $\text{cm}^{-1}$  as well as emergence of a clearly resolved band at 1839 roughly midway between those due to  $\text{W}(\text{CO})_2(\text{phen})(\text{S}^t\text{Bu})_2$  and  $\text{W}(\text{CO})_2(\text{phen})(\text{SPh})_2$ . Addition of a second equivalent of thiophenol resulted in complete conversion to  $\text{W}(\text{CO})_2(\text{phen})(\text{SPh})_2$ . The inter-

mediate peaks are assigned to formation of the mixed complex  $\text{W}(\text{CO})_2(\text{phen})(\text{S}^t\text{Bu})(\text{SPh})$ .

**Reaction of  $\text{W}(\text{CO})_2(\text{phen})(\text{S}^t\text{Bu})_2$  and Hydrogen Sulfide.** In a Schlenk tube in the glovebox, 0.3 g of  $\text{W}(\text{CO})_2(\text{phen})(\text{S}^t\text{Bu})_2$  was dissolved in 50 mL of freshly distilled THF. The green solution was taken out of the glovebox, attached to a vacuum manifold, and filled with  $\text{H}_2\text{S}$  at 1 atm of pressure. The solution turned purple, and a small amount of black precipitate was observed on the sides of the flask after about 1 h. The flask was cooled to  $-15$  °C and filtered into a cooled Schlenk tube. To the filtrate was added 50 mL of heptane resulting in formation of a brown-black precipitate which was isolated on a frit and washed with a small amount of heptane. Yield: 0.13 g, 50%. The infrared spectrum in THF shows two bands at 1948 (vs) and 1847 (s)  $\text{cm}^{-1}$ . Addition of 2 or more equiv of thiophenol to a THF solution of  $\text{W}(\text{CO})_2(\text{phen})(\text{SH})_2$  resulted in a rapid color change from purple to red-brown and appearance of new bands in the infrared at 1945 and 1852  $\text{cm}^{-1}$ , which in both peak shape and position are identical to those of an authentic sample of  $\text{W}(\text{CO})_2(\text{phen})(\text{SPh})_2$  confirmed by FTIR analysis. The complex is stable for short periods of time in solution, more so under an atmosphere of  $\text{H}_2\text{S}$ . It undergoes slow decomposition to unknown products.

**Attempted Reaction of  $\text{W}(\text{CO})_2(\text{phen})(\text{S}^t\text{Bu})_2$  and  $\text{PhSSPh}$ .** In a Schlenk tube a mixture of  $\text{W}(\text{CO})_2(\text{phen})(\text{S}^t\text{Bu})_2$  and  $\text{PhSSPh}$  (1/10 ratio) in THF was stirred under an argon atmosphere for 4 h. A sample was withdrawn and the infrared spectrum showed  $\text{W}(\text{CO})_2(\text{phen})(\text{S}^t\text{Bu})_2$  along with small amounts of  $\text{W}(\text{CO})_4(\text{phen})$  due to decomposition but no sign of formation of  $\text{W}(\text{CO})_2(\text{phen})(\text{SPh})_2$ .

**Reaction of  $\text{W}(\text{CO})_2(\text{phen})(\text{SCH}_2\text{C}_6\text{H}_5)_2$  and HSPH.** A solution of 0.05 g of  $\text{W}(\text{CO})_2(\text{phen})(\text{SCH}_2\text{C}_6\text{H}_5)_2$  in 5 mL of  $\text{CH}_2\text{Cl}_2$  was prepared in a test tube in the glovebox. To the green solution was added 0.022 mL of neat HSPH. The solution turned red brown within 5 min. The infrared spectrum showed complete conversion to  $\text{W}(\text{CO})_2(\text{phen})(\text{SPh})_2$ . In a separate experiment a solution of 0.0148 g of  $\text{W}(\text{CO})_2(\text{phen})(\text{SCH}_2\text{C}_6\text{H}_5)_2$  was prepared in 1.5 mL of  $\text{CD}_2\text{Cl}_2$  and loaded into an NMR tube. To this solution was added 0.007 mL (3 equiv) of thiophenol. The NMR spectrum showed the presence of approximately 1 mol of free thiophenol, as well as peaks at 3.74 (d) and 1.83 (t) assigned to  $\text{HSCH}_2\text{C}_6\text{H}_5$  and  $\text{HSCH}_2\text{C}_6\text{H}_5$ , respectively, as well as peaks due to  $\text{W}(\text{CO})_2(\text{phen})(\text{SPh})_2$ .

**Preparation of  $\text{W}(\text{bipy})(\text{CO})_3(\text{EtCN})$ .** To a 500-mL Schlenk flask was added 6 g of  $\text{W}(\text{CO})_6$ , 3.2 g of 2,2'-bipyridyl (1.2 equiv) and 200 mL of EtCN. The solution was refluxed and magnetically stirred for 36 h resulting in a deep blue color, with fine black crystals forming upon cooling to room temperature. An IR of the EtCN solution showed bands at 1898 and 1785  $\text{cm}^{-1}$ , with only a trace of  $\text{W}(\text{bipy})(\text{CO})_4$  present. The solution was stored in the freezer overnight and then filtered. The 5.8 g of fine black crystals collected on the frit were washed with 15 mL of heptane and dried under vacuo. A sample of the product completely dissolved in  $\text{CH}_2\text{Cl}_2$  and produced a blue/violet colored solution. An IR of this solution showed the product to be pure with bands at 1898.5 and 1782  $\text{cm}^{-1}$ ; yield = 71%.

**Preparation of  $\text{W}(\text{bipy})(\text{CO})_2(\text{SPh})_2$ .** To a 500-mL Schlenk flask was added 2 g of  $\text{W}(\text{bipy})(\text{CO})_3(\text{EtCN})$  and 200 mL of  $\text{CH}_2\text{Cl}_2$ . To this blue colored slurry, 75 mL of a  $\text{CH}_2\text{Cl}_2$  solution containing 15 g of diphenyl disulfide (16.5 equiv) was added. The solution was placed in a 35 °C water bath and stirred magnetically, and a vacuum was maintained for 35 min at which time the reaction was complete and the solution was a red/brown color. With approximately 150 mL of  $\text{CH}_2\text{Cl}_2$  remaining, the solution was filtered and a negligible amount of insoluble material collected. To the filtrate was added 75 mL of heptane, and the solvent was then stripped off until a few crystals were observed to precipitate. Cooling the solution in a freezer yielded a crop of 1.9 g (74%) of brown/red crystals whose FTIR spectra in solution showed bands at 1944.2 and 1852  $\text{cm}^{-1}$  in THF and 1944 and 1847  $\text{cm}^{-1}$  in  $\text{CH}_2\text{Cl}_2$ . Under pressure of CO, 204 psi, new peaks grow in which are assigned to  $\text{W}(\text{bipy})(\text{CO})_3(\text{SPh})_2$  at 1988, 1920, and 1887  $\text{cm}^{-1}$  in THF solution.

## Results and Discussion

The long-range goal of this work is to investigate the thermochemical factors influencing stability in sulfur-containing complexes of group VI. In this paper we report synthesis, crystal structures, and reaction studies of formally 16-electron  $\text{W}(\text{II})$  dithiolate complexes.

**Improved Synthesis of  $\text{W}(\text{CO})_3(\text{phen})(\text{EtCN})$ .** The complex  $\text{W}(\text{CO})_3(\text{phen})(\text{EtCN})$  can be prepared by several routes.

(16) Ju, T. D.; Lang, R. L.; Kiss, G.; Hoff, C. D. Unpublished results.

Reaction of W(CO)<sub>3</sub>(CHPT) (CHPT = cycloheptatriene) in a manner analogous to that described by Behrens and co-workers<sup>17</sup> proceeds in high yield:

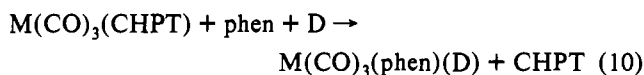

D = donor solvent

A drawback to this preparation is that it requires W(CO)<sub>3</sub>(CHPT), which is best prepared<sup>18</sup> from W(CO)<sub>3</sub>(EtCN)<sub>3</sub>. Reaction of W(CO)<sub>3</sub>(EtCN)<sub>3</sub> with phen also proceeds readily as shown in (11), but the preparation of W(CO)<sub>3</sub>(EtCN)<sub>3</sub> requires

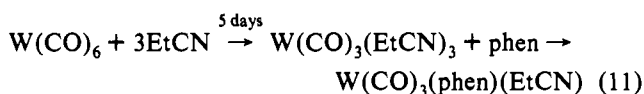

at least 5 days reflux and does not always produce high yields. While we initially prepared W(CO)<sub>3</sub>(phen)(EtCN) by either reaction 10 or 11, addition of the phen ligand to the propionitrile results in higher overall yields and shorter reaction times in the direct reaction:

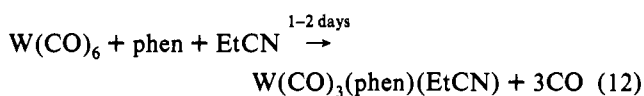

The faster rate of (12) versus (11) is due to the fact that the loss of CO from W(CO)<sub>4</sub>(phen) is significantly faster than loss of CO from W(CO)<sub>4</sub>(EtCN)<sub>2</sub>, in keeping with the well known cis-labilizing effect of phenanthroline and related ligands.<sup>19</sup> Similar procedures are used to prepare the bipyridine analog.

**Reaction of W(CO)<sub>3</sub>(phen)EtCN and PhSSPh.** In the presence of a 20-fold excess of disulfide and under conditions of continuous evacuation to remove the released CO, oxidative addition of phenyl disulfide proceeds in near-quantitative yield as shown in (13).

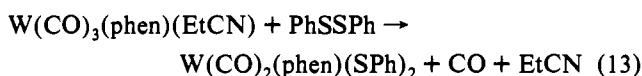

Two side reactions occur which complicate isolation and characterization of the W(II) product. Carbon monoxide released in the reaction reacts rapidly with the starting W(0) nitrile complex:

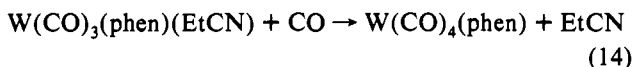

In a closed system with a W/S ratio of 1/1 the stoichiometry of the reaction approaches that of (15).

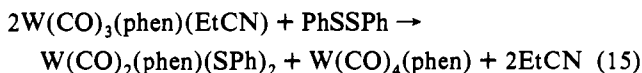

A second side reaction that occurs is formation of cluster complexes. In concentrated solution, varying amounts of precipitate are formed. The same precipitate is formed on mixing W(CO)<sub>2</sub>(phen)(SPh)<sub>2</sub> and W(CO)<sub>3</sub>(phen)(EtCN):

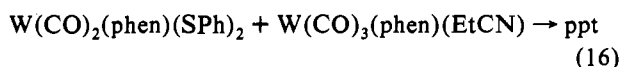

The precipitate is formulated as a simple S-bonded adduct

(17) Behrens, H.; Lindner, E.; Lehnert, G. *J. Organomet. Chem.* **1970**, *22*, 439.

(18) Kubas, G. J. *Inorg. Synth.* **1990**, *27*, 1.

(19) See for example: Kirtley, S. W., In *Comprehensive Organometallic Chemistry*; Wilkinson, G., Stone, F. G. A., Abel, E. W., Eds.; Pergamon Press: Oxford, U.K., Vol. 3, pp 871-876.

[W(CO)<sub>2</sub>(phen)(SPh)<sub>2</sub>][W(CO)<sub>3</sub>(phen)] on the basis of chemical and spectroscopic studies. The stoichiometry of reaction between W(CO)<sub>2</sub>(phen)(SPh)<sub>2</sub> and W(CO)<sub>3</sub>(phen)(EtCN) is 1/1. Addition of strong ligands L = PR<sub>3</sub> or CO results in degradation of the complex to W(II) and W(0) complexes as shown in (17).

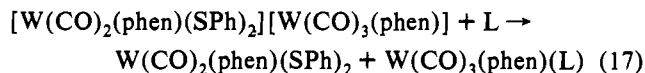

The infrared spectrum (Nujol mull) of the precipitate shows bands characteristic of W(II) and W(0) complexes. The bands at 1949, 1881, 1846, and 1778 cm<sup>-1</sup> are similar in pattern and peak positions to simple addition of the two spectra due to W(CO)<sub>2</sub>(phen)(SPh)<sub>2</sub> (IR bands at bands at 1944 and 1847 cm<sup>-1</sup>) and W(CO)<sub>3</sub>(phen)(EtCN) (bands at 1898 and 1785 cm<sup>-1</sup>). All attempts to obtain X-ray-quality crystals of this complex failed. Due to low solubility, NMR data and molecular weight measurements could not be obtained.

Additional information regarding the course of this reaction was obtained by study of the FTIR spectrum in the first minutes of mixing. New peaks occur in the infrared spectrum at 1910 and 1811 cm<sup>-1</sup> within 30 s of mixing the two solutions.

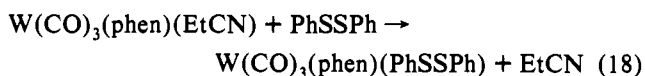

These are similar to peaks for coordination of diphenyl sulfide in the complex W(CO)<sub>3</sub>(phen)(SPh)<sub>2</sub>,<sup>16</sup> which occur at 1906 and 1794 cm<sup>-1</sup>. The shift to higher wavenumbers relative to W(CO)<sub>3</sub>(phen)(EtCN) (1898, 1785 cm<sup>-1</sup>) is expected on the basis of the poorer donor abilities of SPh<sub>2</sub> and PhSSPh. The analogous intermediate complexes W(CO)<sub>3</sub>(phen)(RSSR) (R = CH<sub>2</sub>Ph, Me, <sup>t</sup>Bu) are more stable and show similar vibrational spectra.

These observations are in keeping with the overall mechanism shown in (19). A rapid equilibrium is established with regard to

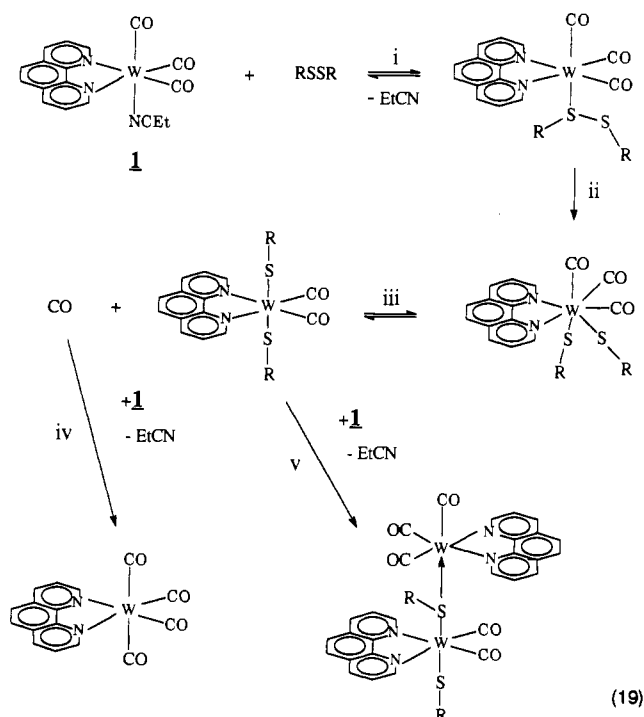

displacement of nitrile by disulfide in step i. Oxidative addition occurs in step ii but has sufficient barrier that the coordinated

(20) A set of Cr(0) dithiolato complexes Cr(CO)<sub>n</sub>(S<sub>2</sub>C<sub>6</sub>R<sub>4</sub>)<sub>2</sub><sup>-</sup> (n = 3, 4) have been reported, and their crystal structures show evidence for π-bonding in the formally coordinatively unsaturated complex n = 3: Sellman, D.; Wille, M.; Knoch, F. *Inorg. Chem.* **1993**, *32*, 2534.

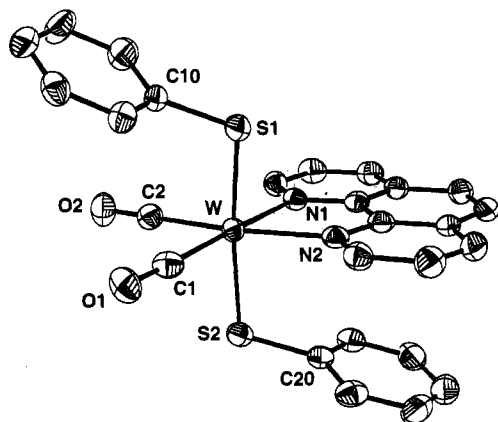

Figure 2. ORTEP diagram for  $W(CO)_2(phen)(SPh)_2$ .

disulfide can be observed for a short time in solution. Reversible (see later section) loss of CO occurs in step iii. Both products of step iii (CO and the W(II) dithiolate) can bind with the starting nitrile complex to generate either  $W(CO)_4(phen)$  (step iv) or the dimeric complex (step v). For optimum yields of  $W(CO)_2(phen)(SR)_2$ , a high ratio of RSSR/W is desirable as well as continuous evacuation of the flask to remove carbon monoxide generated in the reaction. Detailed kinetic study of the mechanism in (19) is in progress.<sup>21</sup>

**Reaction of  $W(CO)_3(phen)(EtCN)$  and RSSR (R = Me, <sup>t</sup>Bu, Benzyl).** The general reaction sequence shown in (19) with diphenyl disulfide appears to be valid for the other disulfides studied here. Reaction with methyl disulfide is somewhat slower, and clear-cut formation of the coordinated disulfide can be observed in the FTIR spectrum as shown in Figure 1. At high concentrations of disulfide, oxidative addition occurs with a half-life of about 4 min at room temperature. At lower concentrations, particularly at the end of the reaction, the presence of equilibrium amounts of  $W(CO)_3(phen)(EtCN)$  as well as the proposed dimeric complex  $[W(CO)_2(phen)(SMe)_2][W(CO)_3(phen)]$  is clearly seen. The relative rates of oxidative addition are in the order  $PhSSPh > benzyl-SS-benzyl > MeSSMe \gg ^tBuSSBu$ . In the case of <sup>t</sup>BuSSBu, presumably for steric reasons, oxidative addition occurs with a half-life of several hours at room temperature. In addition to kinetic factors, thermodynamic factors also play a role in these reactions. For example in related molybdenum chemistry,<sup>16</sup> <sup>t</sup>BuSSBu does not undergo oxidative addition at all but forms instead a stable coordinated disulfide complex. This is in keeping with failure to observe oxidative addition of disulfides to  $M(CO)_5(RSSR)$  complexes as observed by Darensbourg and co-workers<sup>7</sup> for Cr and Abel and co-workers<sup>6</sup> for Mo and W. It is clear that the metal and its ligand environment, as well as the nature of the incoming disulfide, play a critical role in determining the course of these reactions.

The complex  $W(CO)_3(phen)(EtCN)$  reacts with diphenyl disulfide in the same manner as does the phenanthroline analog. Infrared data for these complexes are collected in Table 1, and NMR data in Table 2. The fact that the infrared spectra are not significantly altered in THF,  $CH_2Cl_2$ , and toluene for the W(II) complexes argues against coordination of solvent to the formally 16-electron metal centers.

**Structure of  $W(CO)_2(phen)(SPh)_2$  and  $W(CO)(P(OMe)_3)(phen)(SPh)_2$ .** The structure of the  $W(CO)_2(phen)(SPh)_2$  (I) is shown in Figure 2, and that of  $W(CO)(P(OMe)_3)(phen)(SPh)_2$  (II) is shown in Figure 3. A summary of X-ray diffraction data is collected in Table 3. Selected bond lengths and angles are given in Tables 5 and 6, and complete crystallographic parameters are available as supplementary material. A key feature of these complexes is

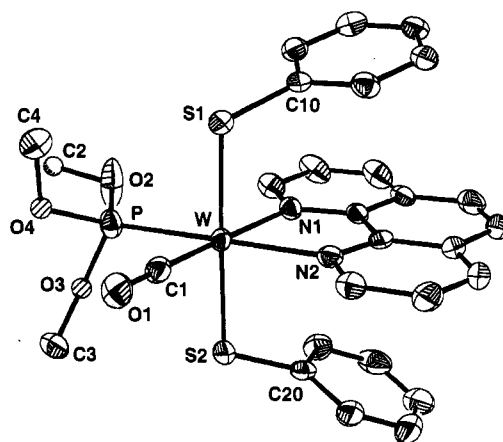

Figure 3. ORTEP diagram for  $W(CO)(P(OMe)_3)(phen)(SPh)_2$ .

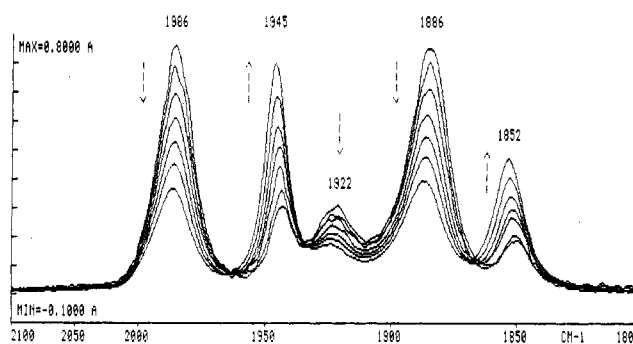

Figure 4. Variable-temperature FTIR study of the reaction  $W(CO)_2(phen)(SPh)_2 + CO \rightleftharpoons W(CO)_3(phen)(SPh)_2$  in THF solution at 230 psi of CO. Peaks at 1986, 1922, and 1886  $cm^{-1}$  are due to the  $W(CO)_2(phen)(SPh)_2$  decrease as the temperature increases from  $-3$  to  $+40$  °C.

Table 3. Summary of X-ray Diffraction Data

	complex	
	$W(SPh)_2(CO)_2(phen)$	$W(SPh)_2(CO)(P(OMe)_3)(phen)$
chem formula	$C_{26}H_{18}N_2O_2S_2W$	$C_{28}H_{18}N_2O_4PS_2W$
<i>a</i> , Å	8.508(3)	31.699(8)
<i>b</i> , Å	18.547(6)	8.340(2)
<i>c</i> , Å	14.453(4)	20.412(5)
$\beta$ , deg	98.35(2)	94.35(2)
<i>V</i> , Å <sup>3</sup>	2256	5381
<i>Z</i>	4	8
fw	638.4	725.4
space group	$P2_1/c$ (No. 14)	$C2/c$ (No. 15)
<i>T</i> , °C	-70	-70
$\lambda$ , Å	0.710 73	0.710 73
$\rho_{calcd}$ , g cm <sup>-3</sup>	1.88	1.79
$\mu$ , cm <sup>-1</sup>	53.3	45.5
scan type	$\theta-2\theta$	$\omega$
trasm coeff	0.003-0.018	0.24-0.37
<i>R</i>	0.037	0.024
<i>R<sub>w</sub></i>	0.045	0.031

their nearly octahedral geometry. Thus the S-W-S angles are 168.1 and 178.0° for  $W(CO)_2(phen)(SPh)_2$  and  $W(CO)(P(OMe)_3)(phen)(SPh)_2$ , respectively. The W-SPh bond lengths in I have statistically significant different bond lengths of 2.354(2) and 2.368(2) Å for the two thiolate groups, and both are shorter than the nearly even values of 2.373(1) and 2.371(1) Å determined for II. It is not clear if that is due to steric or electronic factors or both. In view of the stronger  $\pi$ -acidity of CO, shortening of the bond due to increased double-bond character from thiolate to metal in the dicarbonyl I might be expected; however, steric repulsion could also result in a longer W-S bond length in the phosphite derivative. It is of interest to note that the phenyl groups are effectively trans to each other in the dicarbonyl but in a cis orientation (both are over the phenanthroline ligand) in

(21) The authors wish to thank one of the reviewers for suggesting this comparison.

Table 4. Selected Bond Lengths (Å) and Angles (deg)

	W(SPh) <sub>2</sub> (CO) <sub>2</sub> (phen)	W(SPh) <sub>2</sub> (CO)(P(OMe) <sub>3</sub> )(phen)
W-S(1)	2.354(2)	2.373(1)
W-S(2)	2.368(2)	2.371(1)
W-P		2.410(1)
W-N(1)	2.217(5)	2.230(4)
W-N(2)	2.215(6)	2.203(4)
W-C(1)	2.007(6)	1.947(5)
W-C(2)	1.966(7)	
S(1)-C(10)	1.776(6)	1.786(5)
S(2)-C(20)	1.788(7)	1.779(5)
C(1)-O(1)	1.140(8)	1.169(6)
C(2)-O(2)	1.144(8)	
S(1)-W-S(2)	168.1(1)	178.0(1)
S(1)-W-P		91.3(1)
S(2)-W-P		90.7(1)
S(1)-W-N(1)	92.9(1)	88.7(1)
S(2)-W-N(1)	92.1(1)	91.4(1)
P-W-N(1)		103.6(1)
S(1)-W-N(2)	81.9(1)	90.5(1)
S(2)-W-N(2)	89.2(1)	87.5(1)
P-W-N(2)		176.4(1)
S(1)-W-C(1)	90.4(2)	90.1(1)
S(2)-W-C(1)	85.0(2)	89.7(1)
P-W-C(1)		79.6(1)
N(1)-W-C(1)	176.3(2)	176.6(2)
N(2)-W-C(1)	108.9(2)	103.5(2)
S(1)-W-C(2)	96.0(2)	
S(2)-W-C(2)	93.7(2)	
N(1)-W-C(2)	100.7(2)	
N(2)-W-C(2)	173.5(2)	
C(1)-W-C(2)	77.2(3)	
W-S(1)-C(10)	112.2(2)	109.2(2)
W-S(2)-C(20)	110.2(2)	111.7(2)
W-C(1)-O(1)	175.3(6)	179.1(4)
W-C(2)-O(2)	178.8(6)	

Table 5. Selected Coordinates ( $\times 10^4$ ) and  $U_{eq}$  Values for W(SPh)<sub>2</sub>(CO)<sub>2</sub>(phen)

	x	y	z	$U_{eq}^a$
W	369(1)	2333(1)	1493(1)	24(1)
S(1)	2386(2)	2113(1)	573(1)	36(1)
S(2)	-1355(2)	2387(1)	2639(1)	32(1)
N(1)	-1475(6)	1813(3)	467(3)	26(1)
N(2)	605(6)	1155(3)	1728(3)	28(2)
O(1)	2773(6)	3177(3)	2964(3)	44(2)
O(2)	-115(6)	3948(3)	946(3)	45(2)
C(1)	1927(8)	2843(4)	2448(5)	34(2)
C(2)	48(7)	3352(4)	1140(4)	31(2)

<sup>a</sup> Equivalent isotropic  $U_{eq}$  defined as one-third of the trace of the orthogonalized  $U_{ij}$  tensor and given in units of  $\text{\AA}^2 \times 10^3$ .

Table 6. Selected Coordinates ( $\times 10^4$ ) and  $U_{eq}$  Values for W(SPh)<sub>2</sub>(CO)(P(OMe)<sub>3</sub>)(phen)

	x	y	z	$U_{eq}^a$
W	3642(1)	2126(1)	7491(1)	19(1)
S(1)	4130(1)	4158(2)	7246(1)	27(1)
S(2)	3139(1)	167(2)	7749(1)	26(1)
P	4000(1)	196(2)	6851(1)	27(1)
C(1)	3340(1)	2430(6)	6634(2)	25(2)
O(1)	3153(1)	2603(5)	6122(2)	36(1)
N(1)	3975(1)	1920(5)	8490(2)	22(1)
N(2)	3324(1)	3793(5)	8130(2)	22(1)

<sup>a</sup> Equivalent isotropic  $U_{eq}$  defined as one-third of the trace of the orthogonalized  $U_{ij}$  tensor and given in units of  $\text{\AA}^2 \times 10^3$ .

the phosphite derivative. Presumably this is due to a combination of crystal packing forces and steric repulsion between the phosphite ligand and the thiolate.

An additional point of interest is that for the phosphite derivative the W-N bonds are different for the two phenanthroline nitrogen atoms, whereas they are identical within experimental error for the dicarbonyl. The asymmetrical nature of this environment is confirmed in the NMR spectral data (Table 2), which shows

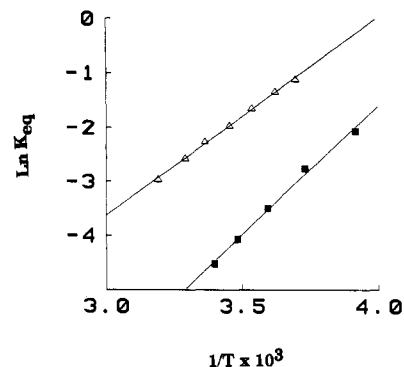
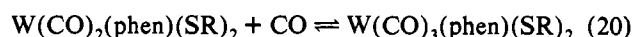

Figure 5. Plots of  $\ln K_{eq}$  versus  $1/T$  ( $10^3 \text{ K}^{-1}$ ) for the reactions  $W(CO)_2(phen)(SR)_2 + CO \rightleftharpoons W(CO)_3(phen)(SR)_2$ , with points for  $R = Ph$  shown as triangles and  $R = tBu$  as squares.

splitting of the phenanthroline protons in this and other<sup>16</sup> unsymmetrical phenanthroline complexes in this family.

The two structures in the literature that most resemble these complexes are  $Mo(CO)_2(bipy)(dpt)_2$  ( $dpt = \text{diphenylthiophenol}$ )<sup>11</sup> and  $M(CO)_2(SC_6H_2Pr_3)_2(PMe_2Ph)_2$  ( $M = Mo, W$ ).<sup>10</sup> The structure of the phosphine-substituted complexes is trigonal prismatic<sup>10</sup> whereas the bipyridyl derivative has nearly octahedral<sup>11</sup> geometry. The structures of I and II resemble more closely the molybdenum bipyridyl derivative. It is tempting to look for evidence of  $\pi$  bonding interactions between lone pairs on the thiolates and the formally 16-electron tungsten atom in the structural parameters.<sup>20</sup> This would be expected to be seen in changes in the  $W-S_1-C_{10}$  and  $W-S_2-C_{20}$  angles.<sup>21</sup> In the authors opinion, insufficient structural data are available to make definitive conclusions regarding this. As the number of related structures increases, that situation may change. Of particular interest would be comparison between 16- and 18-electron complexes of W(II) thiolates. Attempts to obtain crystals of the corresponding tricarbonyl complexes are in progress.

**Equilibrium Data for  $W(CO)_2(phen)(SR)_2 + CO \rightleftharpoons W(CO)_3(phen)(SR)_2$ .** The complexes  $W(CO)_2(phen)(SR)_2$  reversibly bind CO as shown in (20). Quantitative determination of the



equilibrium constants in THF solution as a function of temperature was undertaken for the  $R = Ph$  and  $tBu$  derivatives in the temperature range  $-10$  to  $+40$  °C and in the pressure range 0–300 psi CO. Plots of  $\ln K_{eq}$  versus  $1/T$  are shown in Figure 5. Thermodynamic parameters derived from these plots are as follows: for  $R = \text{phenyl}$ ,  $\Delta H = -7.2 \pm 0.5$  kcal/mol and  $\Delta S = -29 \pm 3.5$  cal/(mol deg); for  $R = \text{tert-butyl}$ ,  $\Delta H = -9.5 \pm 0.5$  kcal/mol and  $\Delta S = -41 \pm 3.5$  cal/(mol deg). Similar values were obtained in toluene solution.<sup>16</sup> Qualitative observations had indicated that higher pressures of CO were needed to coordinate for  $R = \text{tert-butyl}$  than for  $R = \text{phenyl}$ . The thermodynamic studies showed that that was due to entropic rather than enthalpic factors.

The high negative entropies of binding of carbon monoxide are in the range expected for ligand binding.<sup>22</sup> If the complexes had solvent bound to the vacant site, and the observed spectral changes corresponded to displacement of coordinated solvent as shown in eq 21, entropy changes closer to zero would have been expected.

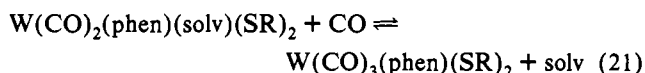

This observation is also in keeping with the observed independence of the infrared spectrum of the  $W(CO)_2(phen)(SR)_2$  complexes

in different solvents. The more negative entropy of binding of CO to the *tert*-butyl complex may reflect the stricter steric demands of this group and hindered rotation of the organic groups in the seven-coordinate tricarbonyl complex.

These observations indicate that the enthalpy of addition of carbon monoxide in these W(II) complexes corresponds to direct measurement of the W(II)–CO bond strength in these complexes. The values are on the order of 8 kcal/mol. That is in sharp contrast to the value of 46.5 kcal/mol for the W(0) complex W(CO)<sub>6</sub> as determined by laser studies by Smith.<sup>23</sup>

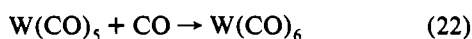

To the authors' knowledge, this is the first determination of the W–CO bond strength for W(II). It is well-known that the M–CO bond strength depends critically on back-donation. Nevertheless the almost 40 kcal/mol decrease in bond strength upon oxidation by the relatively mild sulfur donors here is somewhat surprising. It seems possible to the authors that this may be due to partial double-bond character in the formally 16-electron thiolate complex W(CO)<sub>2</sub>(phen)(SR)<sub>2</sub> due to donation of lone pairs on sulfur to empty orbitals on the metal. Bercaw and Bryndza<sup>24</sup> have come to similar conclusions in kinetic studies of phosphine displacement:

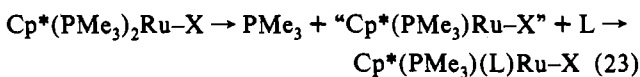

Enthalpies of activation for phosphine dissociation depended strongly on the nature of X. The lower activation energies for X groups containing lone pairs of electrons (such as NPh<sub>2</sub> and SPh) was attributed to partial double-bond character in stabilization of "Cp\*(PMe<sub>3</sub>)Ru=X". Regardless of whether there is double bonding in the complexes W(CO)<sub>2</sub>(phen)(SR)<sub>2</sub> only weak interactions with CO occur.

**Ligand Binding and Substitution Reactions for W(CO)<sub>2</sub>(phen)(SR)<sub>2</sub>.** The observed binding under pressure of CO led to investigation of reactions of other ligands. It was also of interest to investigate the nature of the "vacant site" in this complex. The relatively weak binding of CO could be due to the fact that it is a weakly bound ligand for W(II) and that it derives most of its strength from back-bonding. If a decrease in back-bonding were the cause of the weak interaction with CO, more basic ligands might be expected to show stronger bonding. In fact, CO proved to be a strong ligand and was able to displace all ligands studied for this system. Pyridine, EtCN, THF, H<sub>2</sub>, and R<sub>2</sub>S showed no ability to bind to W(CO)<sub>2</sub>(phen)(SPh)<sub>2</sub>. Trimethylphosphine, however, underwent rapid addition to W(CO)<sub>2</sub>(phen)(SPh)<sub>2</sub> forming the stable seven-coordinate adduct W(CO)<sub>2</sub>(PMe<sub>3</sub>)(phen)(SPh)<sub>2</sub>. This complex loses CO and forms equilibrium amounts of the 16-electron phosphine-substituted "coordinatively unsaturated" complex W(CO)(PMe<sub>3</sub>)(phen)(SPh)<sub>2</sub>. These reactions appear to be fully reversible, and the complex equilibrium shown in (24) is established and can be shifted to the left or right

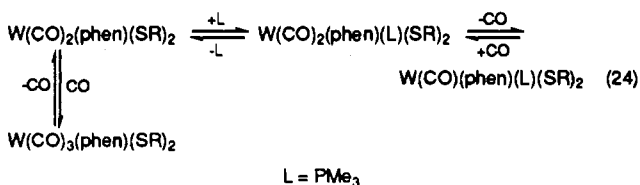

depending upon the carbon monoxide pressure, the trimethylphosphine concentration, and the temperature. Quantitative

investigation of the thermochemistry of these and related reactions is in progress.

Reaction with P(OMe)<sub>3</sub> showed no signs of formation of W(CO)<sub>2</sub>(P(OMe)<sub>3</sub>)(phen)(SPh)<sub>2</sub>, only slow formation of W(CO)(P(OMe)<sub>3</sub>)(phen)(SPh)<sub>2</sub>, the crystal structure of which is shown in Figure 3. Addition of 250 psi of carbon monoxide to the 16-electron phosphite/thiolate complex also failed to generate any evidence for formation of the 18-electron substituted complex W(CO)<sub>2</sub>(P(OMe)<sub>3</sub>)(phen)(SPh)<sub>2</sub>, resulting only in quantitative displacement of coordinated phosphite by CO. The reaction sequence shown in (24) for PMe<sub>3</sub> is probably also valid for P(OMe)<sub>3</sub> except for the instability of W(CO)<sub>2</sub>(phen)(P(OMe)<sub>3</sub>)(SPh)<sub>2</sub>. This series of complexes provides a good starting place for understanding ligand binding parameters in formally 16-electron W(II) complexes. To the authors knowledge, little data is available for these complexes compared to W(0).<sup>14</sup>

**Attempted Hydrogenation of W(CO)<sub>2</sub>(phen)(SR)<sub>2</sub>.** One goal of this work is to find conditions where hydrogen will cleave the metal–sulfur bond to produce thiols. Thus we attempted reaction of W(CO)<sub>2</sub>(phen)(SPh)<sub>2</sub> at room temperature with H<sub>2</sub> at 1000 psi. Over 1 week of time, no reaction was observed. In a similar attempt, we added 200–300 psi of CO and then 700–800 psi of H<sub>2</sub> and observed the FTIR spectrum under these conditions. At the end of 1 week of time, only an equilibrium mixture of W(CO)<sub>x</sub>(phen)(SR)<sub>2</sub> (x = 2, 3) was observed. The anticipated reaction to reductively eliminate thiol did not occur:

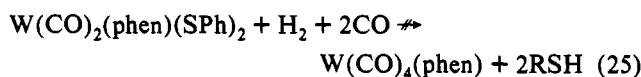

At this time it is not known if failure to observe reaction 25 is due to thermodynamic or kinetic factors, but additional work is in progress to clarify this. It seems clear from these studies that the formally 16-electron complexes do have an accessible site of reactivity, but no interactions with hydrogen have been found as yet.

**Thiol Exchange Reactions.** Darensbourg<sup>25</sup> has reported that, in ionic complexes, thiol/thiolate exchange occurs relatively rapidly and that this likely involves hydrogen-bonded intermediates as shown in (26). In that regard the displacement reactions

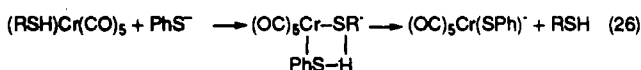

shown in (27) were investigated. Addition of 2 or more equiv of

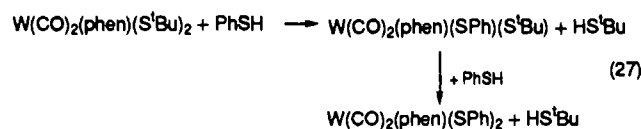

thiophenol to the *tert*-butyl thiolate complex proceeds quantitatively to the final product W(CO)<sub>2</sub>(phen)(SPh)<sub>2</sub>. Addition of only 1 equiv shows formation of the intermediate mixed dithiolate W(CO)<sub>2</sub>(phen)(SPh)(S<sup>t</sup>Bu). Similar displacement reactions occur for a range of thiols including hydrogen sulfide and provide a basis not only for synthesis of new complexes but also for calorimetric measurements.<sup>16</sup>

Attempted thiolate exchange reactions involving disulfides such as that shown in (28) below did not occur at room temperature.

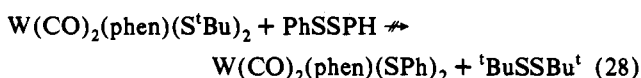

(23) Smith, G. P. *Polyhedron* 1988, 7, 1605–1608.

(24) Bryndza, H. E.; Domaille, P. J.; Tam, W.; Fong, L. K.; Paciello, R. A.; Bercaw, J. E. *Polyhedron* 1988, 7, 1441–1452.

(25) Darensbourg, M. Y.; Longridge, E. M.; Payne, V.; Reibenspies, J.; Riordan, C. G.; Springs, J. J.; Calabrese, J. C. *Inorg. Chem.* 1990, 29, 2721–2726.



This cannot be due to thermodynamic reasons<sup>26</sup> and reflects the more sluggish reactivity of the sulfur–sulfur versus the sulfur–hydrogen bond. It also adds credence to the postulate of an H-bonded intermediate in these reactions as proposed by Darenbourg and co-workers.<sup>25</sup>

Finally, it should be mentioned that reaction of the complex W(CO)<sub>2</sub>(phen)(S<sup>t</sup>Bu)<sub>2</sub> [which appears to be thermodynamically the least stable of the bis(thiolate) complexes investigated here<sup>16</sup>] with hydrogen sulfide results in cleavage of <sup>t</sup>BuSH as shown in (29). The complex is formulated as W(CO)<sub>2</sub>(phen)(SH)<sub>2</sub> on the

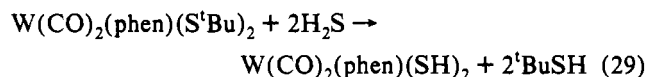

basis of its infrared spectrum and the fact that treatment of this complex with thiophenol results in quantitative formation of W(CO)<sub>2</sub>(phen)(SPh)<sub>2</sub> as shown in (30). The sulfhydryl complex is highly reactive, and its chemistry is under further investigation.

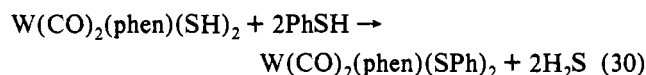

### Conclusion

This paper reports synthesis and reactions of a series of 16-electron W(II) thiolate complexes that are readily obtained via

(26) This conclusion is based on thermochemical cycles incorporating the known heats of hydrogenation of the disulfides,<sup>22</sup> and calorimetric results on enthalpies of thiol/thiolate exchange.<sup>16</sup>

oxidative addition of W(0) compounds. The reaction proceeds through intermediate coordinated disulfide complexes which can be detected spectroscopically. Crystal structures have been reported for the R = phenyl derivative and also the phosphite-substituted complex W(CO)(P(OMe)<sub>3</sub>)(phen)(SPh)<sub>2</sub>. The 16-electron W(II) dithiolates undergo a number of reactions: (i) reversible binding of CO; (ii) reversible binding of phosphines and phosphites; (iii) reaction with thiols to undergo thiol/thiolate exchange; (iv) formation of W(II)/W(0) dimers through the S-bridged thiolates.

Thermodynamic studies of binding of CO to the W(II) bis(thiolates) indicate that the W(II)–CO bond strength in these complexes is on the order of 8 kcal/mol—some 40 kcal/mol weaker than in W(CO)<sub>6</sub>. This is attributed to the expected inherent weakening of the W–CO bond for higher valent complexes but could also be due to partial double-bond character in the tungsten–sulfur bonds. Calorimetric studies in progress on these and related complexes may provide additional insight into the strengths of group VI–sulfur bonds.

**Acknowledgment.** Support of this work by the National Science Foundation, Grant CHE-9221265, and ACS-PRF (C.D.H.) as well as by the U.S. Department of Energy, Division of Chemical Sciences, Office of Basic Energy Sciences (G.J.K.), is gratefully acknowledged.

**Supplementary Material Available:** Tables of anisotropic parameters, atomic positional and thermal parameters, and complete bond distances and angles and figures showing atom numbering for W(CO)<sub>2</sub>(phen)(SPh)<sub>2</sub> and W(CO)(phen)(P(OMe)<sub>3</sub>)(SPh)<sub>2</sub> (11 pages). Ordering information is given on any current masthead page.