

# Supermacrochelate Complexes Containing an Artificial Nucleic Acid Backbone and Derived from Excellent Ligands Formed by Treating Platinum Anticancer Agents with Nucleotide Triphosphates

Anvarhusein A. Isab and Luigi G. Marzilli\*

Department of Chemistry, Emory University, Atlanta, Georgia 30322

Received August 11, 1998

We have discovered that a diverse class of potent metal-ion chelators,  $cis\text{-A}_2\text{Pt}(\text{NTP})_2$ , form novel  $cis\text{-A}_2\text{Pt}(\text{NTP})_2\text{M}$  complexes with unusual properties ( $\text{A}_2$  = two amines or a diamine, NTP = nucleotide triphosphate). Formed by two metals and two NTPs,  $cis\text{-A}_2\text{Pt}(\text{NTP})_2\text{M}$  are named "supermacrochelate complexes" by analogy to typical MNTP macrochelate complexes formed by one metal and one nucleotide (Scheme 1). These "supermacrochelate ligands" are readily prepared in aqueous solution by exploiting the well-developed chemistry of  $cis$ -type Pt anticancer compounds,  $cis\text{-A}_2\text{PtX}_2$ .<sup>1–12</sup>

We illustrate the properties of supermacrochelate ligands with  $\text{enPt}(5'\text{-GTP})_2$  ( $5'\text{-GTP}$  = guanosine 5'-triphosphate; **en** = ethylenediamine);<sup>13</sup> at pH 7 and below, this ligand competes for  $\text{La}^{3+}$  with the very strong ligand EDTA ( $\log K = 15$  for  $\text{La}$ -(EDTA)).<sup>14</sup> The linking of two nucleotides in this way by  $\text{La}^{3+}$  creates an unusual artificial metal-linked sugar–phosphate backbone; the "backbone" link in  $\text{enPt}(5'\text{-GTP})_2\text{La}$  persists intact even at pH 1.5. The supermacrochelate complex can be viewed as a model of the cross-link formed by  $cis$ -type Pt anticancer drugs and N7 of adjacent G residues in DNA (G = guanine nucleotide).<sup>15</sup> The simplest  $cis\text{-PtA}_2\text{G}_2$  cross-link models do not have the G's linked except by Pt; such models exist as just one  $C_2$ -symmetrical head-to-tail (HT) form with  $\Delta$  chirality in crystalline solids.<sup>5,16–19</sup> In solution, the presence of only one H8  $^1\text{H}$  NMR signal has long been presumed to indicate that the models exist as an  $\sim 1:1$  mixture of  $\Delta$  and  $\Lambda$  HT atropisomers that rapidly equilibrate by rotation about the  $\text{Pt}\text{-N}7(\text{G})$  bonds.<sup>4,5,20</sup> The  $^1\text{H}$  NMR spectrum of the supermacrochelate ligand,  $\text{enPt}(5'\text{-GTP})_2$ ,

Scheme 1

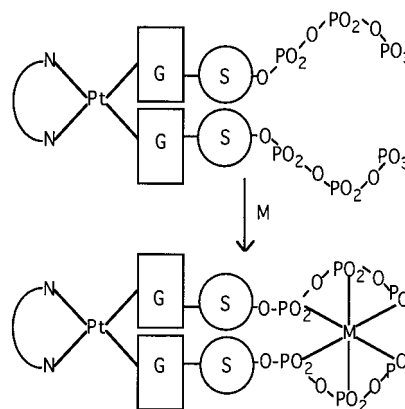

has one major H8 singlet at 8.48 ppm (Figure 1) shifted  $\sim 0.4$  ppm downfield from 8.09 ppm for  $5'\text{-GTP}$ . Thus,  $\text{enPt}(5'\text{-GTP})_2$  is representative of the previously studied simple models that presumably exist as a rapidly interconverting mixture of  $\Delta$  and  $\Lambda$  HT atropisomers.

When  $\text{La}^{3+}$  was titrated into an  $\text{enPt}(5'\text{-GTP})_2$  solution, new signals assignable to  $\text{H}1'$  and to one  $\text{H}5'/5''$  proton of  $\text{enPt}(5'\text{-GTP})_2\text{La}$  emerged at 5.94 and 4.00 ppm. At an  $\sim 1:1$   $\text{enPt}(5'\text{-GTP})_2:\text{La}^{3+}$  ratio, the new  $\text{H}1'$  signal dominated (Figure 1), and above this ratio the spectral changes ceased, demonstrating a 1:1 stoichiometry. This observation of separate resonances indicates slow  $\text{La}^{3+}$  exchange on the NMR time scale. Compelling  $^{17}\text{O}$ ,  $^{31}\text{P}$ , and  $^1\text{H}$  NMR spectroscopic evidence on  $\text{La}(5'\text{-ATP})_2$  demonstrated that  $\text{La}^{3+}$  was bound to oxygens of all three phosphate groups of both  $5'\text{-ATP}$ 's.<sup>21</sup> Since  $\text{La}(5'\text{-ATP})_2$  is in fast exchange, we believe our observation of slow exchange for the supermacrochelate  $\text{enPt}(5'\text{-GTP})_2\text{La}$  complex is strong evidence for the binding of phosphate groups from both  $5'\text{-GTP}$ 's.

Models with all six phosphate groups bound to  $\text{La}$  place the  $\gamma$  phosphate groups close to the respective  $\text{C}5'\text{H}_2$  group. Such proximity could account for the strong shift of only one sugar  $^1\text{H}$  NMR signal, which is an  $\text{H}5'/5''$  signal. Furthermore, when the pH was decreased from 7.0 to  $\sim 2$ , the only  $5'\text{-GTP}$   $^1\text{H}$  resonance to shift appreciably was this one upfield-shifted  $\text{H}5'/5''$  signal; thus, even at low pH,  $\text{enPt}(5'\text{-GTP})_2\text{La}$  is very stable and probably protonated at the  $\gamma$  phosphate(s). A more dramatic indication of the stability of  $\text{enPt}(5'\text{-GTP})_2\text{La}$  derives from competition studies with 0.5 equiv of EDTA at pH 7.0 (Figure 2). The  $^1\text{H}$  NMR signals of free and bound EDTA are well known,<sup>22</sup> and both types were observed, demonstrating that only 80% of the EDTA was bound to  $\text{La}$ ; a similar percentage of the  $\text{H}1'$  resonance for  $\text{enPt}(5'\text{-GTP})_2$  was observed. Both  $\text{La}(\text{EDTA})$  and  $\text{enPt}(5'\text{-GTP})_2\text{La}$  are in slow exchange on the NMR time scale at room temperature and pH 7. In a similar experiment

(21) Shyy, Y.-J.; Tsai, T.-C.; Tsai, M.-D. *J. Am. Chem. Soc.* **1985**, *107*, 3478.

(22) Ryhl, T. *Acta Chem. Scand.* **1972**, *26*, 4001.

- (1) Lippert, B. *J. Am. Chem. Soc.* **1981**, *103*, 5691.
- (2) Lippert, B.; Raudaschl, G.; Lock, C. J. L.; Pilon, P. *Inorg. Chim. Acta* **1984**, *93*, 43.
- (3) Kiser, D.; Intini, F. P.; Xu, Y.; Natile, G.; Marzilli, L. G. *Inorg. Chem.* **1994**, *33*, 4149.
- (4) Xu, Y.; Natile, G.; Intini, F. P.; Marzilli, L. G. *J. Am. Chem. Soc.* **1990**, *112*, 8177.
- (5) Cramer, R. E.; Dahlstrom, P. L. *J. Am. Chem. Soc.* **1979**, *101*, 3679.
- (6) Cramer, R. E.; Dahlstrom, P. L. *Inorg. Chem.* **1985**, *24*, 3420.
- (7) Dijt, F. J.; Canters, G. W.; den Hartog, J. H.; Marcelis, A. T. M.; Reedijk, J. *J. Am. Chem. Soc.* **1984**, *106*, 3644.
- (8) Miller, S. K.; Marzilli, L. G. *Inorg. Chem.* **1985**, *24*, 2421.
- (9) Reily, M. D.; Marzilli, L. G. *J. Am. Chem. Soc.* **1986**, *108*, 8299.
- (10) Reily, M. D.; Hambley, T. W.; Marzilli, L. G. *J. Am. Chem. Soc.* **1988**, *110*, 2999.
- (11) Ano, S. O.; Intini, F. P.; Natile, G.; Marzilli, L. G. *J. Am. Chem. Soc.* **1997**, *119*, 8570.
- (12) Pasini, A.; De Giacomo, L. *Inorg. Chim. Acta* **1996**, *248*, 225.
- (13) Overall charges on the complexes depend on the protonation state, solvent, pH, etc. and therefore are not specified, as is customary for such nucleotide complexes.
- (14) Smith, R. M.; Martell, A. E. *Critical Stability Constants*, 2nd ed.; Plenum Press: New York, 1989; Vol. 6, p 96.
- (15) Reedijk, J. *J. Chem. Soc., Chem. Commun.* **1996**, 801.
- (16) Gellert, R. W.; Bau, R. *J. Am. Chem. Soc.* **1975**, *97*, 7379.
- (17) Marzilli, L. G.; Chalilpoyil, P.; Chiang, C. C.; Kistenmacher, T. J. *J. Am. Chem. Soc.* **1980**, *102*, 2480.
- (18) Orbell, J. D.; Taylor, M. R.; Birch, S. L.; Lawton, S. E.; Vilkins, L. M.; Keefe, L. *J. Inorg. Chim. Acta* **1988**, *152*, 125.
- (19) Barnham, K. J.; Bauer, C. J.; Djuran, M. I.; Mazid, M. A.; Rau, T.; Sadler, P. J. *Inorg. Chem.* **1995**, *34*, 2826.
- (20) Hambley, T. W. *Inorg. Chem.* **1988**, *27*, 1073.

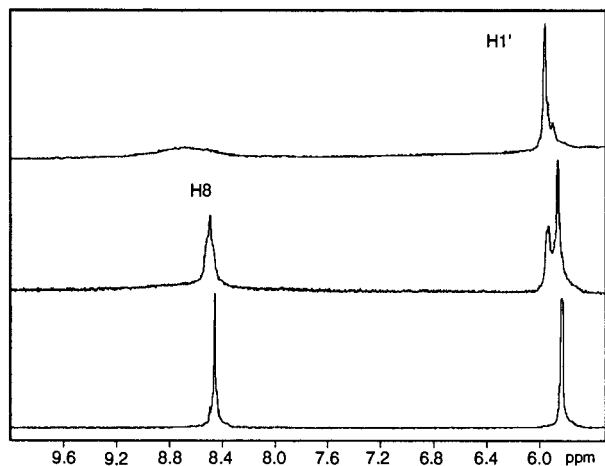

**Figure 1.** H8 and H1'  $^1\text{H}$  NMR signals of  $\text{enPt}(5'\text{-GTP})_2$  (4.48 mM) at pH 7: (bottom) no  $\text{La}^{3+}$ ; (middle) 0.5 equiv of  $\text{La}^{3+}$ ; (top) 1 equiv of  $\text{La}^{3+}$ . The chemical shifts (ppm) not given in text follow in the order  $\text{enPt}(5'\text{-GTP})_2\text{La}/\text{enPt}(5'\text{-GTP})_2/\text{free } 5'\text{-GTP}$ : H1', 5.93/5.87/5.89; H2', under  $\text{H}_2\text{O}/4.67/4.74$ ; H3', 4.48/4.55/4.55; H4', 4.28/4.20/4.32; H5'/5'', 4.14, 4.00/4.20/4.20.

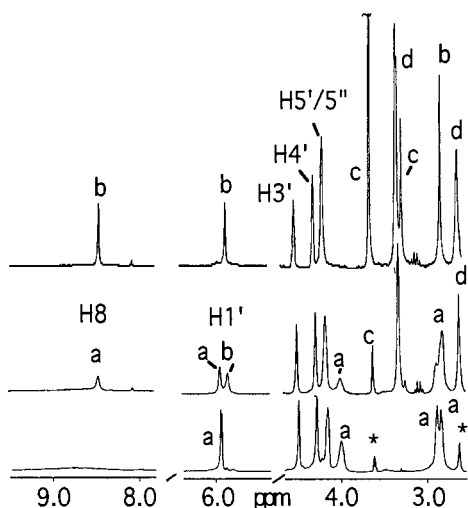
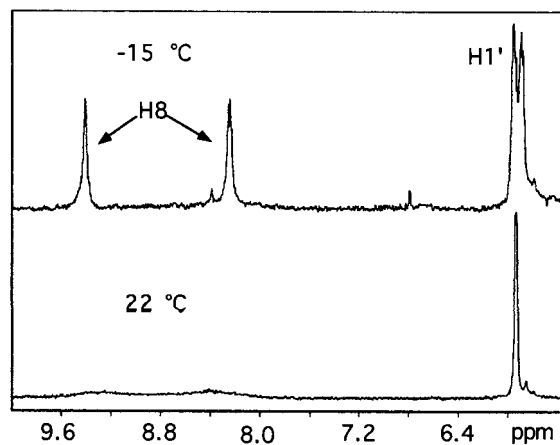

**Figure 2.**  $^1\text{H}$  NMR signals of:  $\text{enPt}(5'\text{-GTP})_2\text{La}$  (bottom), and with 0.5 equiv (middle), and 1.5 equiv (top) of EDTA. Resonance assignments are as follows: (a) =  $\text{enPt}(5'\text{-GTP})_2\text{La}$ ; (b) =  $\text{enPt}(5'\text{-GTP})_2$ ; (c) = free EDTA; and (d) =  $\text{La}(\text{EDTA})$ . Minor inert impurities from  $5'\text{-GTP}$  or  $\text{enPtCl}_2$  are marked with \*.

conducted at pH 5 (not shown), only 34% of the EDTA was bound, indicating a greater stability for  $\text{enPt}(5'\text{-GTP})_2\text{La}$  than for  $\text{La}(\text{EDTA})$  at this pH.

At 20  $^\circ\text{C}$  the H8 resonance of  $\text{enPt}(5'\text{-GTP})_2\text{La}$  (4.30 mM) was so broad as to be almost undetectable (Figure 1). When the temperature was incrementally increased, the H8 resonance could be clearly observed at  $\sim 8.7$  ppm at 45  $^\circ\text{C}$ . This signal became sharper when the temperature was raised to 75  $^\circ\text{C}$ . No significant shift change was observed in this signal or in any ribose resonances as the temperature was increased. We attribute the broad H8 signal at room temperature to an intermediate rate for atropisomerization of the  $\Delta$  and  $\Lambda$  HT forms, which, as mentioned above, are presumed to exist in dynamic  $\text{cis-PtA}_2\text{G}_2$  complexes. The H8 signal sharpening results from the increasing rate of atropisomerization with temperature. The broadening is clearly not due to  $\text{La}^{3+}$  exchange.

To examine solutions below 0  $^\circ\text{C}$ , a 5:2  $\text{D}_2\text{O}/\text{acetone-}d_6$  mixture was employed (Figure 3). In this solvent mixture, two very broad



**Figure 3.** H8 and H1'  $^1\text{H}$  NMR signals of  $\text{enPt}(5'\text{-GTP})_2\text{La}$  (2.14 mM) in 5:2  $\text{D}_2\text{O}/\text{acetone-}d_6$  (pH 7.0 before addition of acetone).

H8 resonances observed for  $\text{enPt}(5'\text{-GTP})_2\text{La}$  at 22  $^\circ\text{C}$  sharpened and shifted  $<0.05$  ppm to 9.43 and 8.25 ppm at  $-15$   $^\circ\text{C}$ . The signals were similar but not of identical intensity, indicating that they arise from HT species. At  $-15$   $^\circ\text{C}$ ,  $\text{enPt}(5'\text{-GTP})_2$  has a somewhat broad H8 signal with a shift of 8.73 ppm, a value similar to the average H8 shift (8.84 ppm) of  $\text{enPt}(5'\text{-GTP})_2\text{La}$ . These results indicate that  $\text{enPt}(5'\text{-GTP})_2$  exists as a mixture of HT forms (as long suspected for simple  $\text{cis-PtA}_2\text{G}_2$  cross-link models) with an atropisomerization rate starting to slow at  $-15$   $^\circ\text{C}$  and that the  $\text{La}^{3+}$  serves the role of trapping the two HT forms. The rather upfield shift of one HT form of  $\text{enPt}(5'\text{-GTP})_2\text{La}$  at 8.25 ppm suggests that the G bases are tilted into a pseudo stacked form.<sup>23</sup> The other HT form has a quite unusually downfield H8 signal attributable to the absence of tilt and/or a deshielding effect of the phosphate groups.

In conclusion, we have identified a new type of complex with a chelate ligand incorporating Pt as a constituent. The ligand, named a supermacrochelate, has a high affinity for  $\text{La}^{3+}$ . Complexation creates a rather unique symmetrical backbone containing phosphate and natural sugar groups, as well as  $\text{La}^{3+}$ .<sup>24</sup> A symmetrical backbone allows unambiguous evaluation of dynamic motion and atropisomer distribution, and the novel complex studied here provided such evidence. In contrast, the natural backbone of  $\text{cis-PtA}_2(\text{dGpG})$  is unsymmetrical, with a 3' and a 5' nucleotide. The appearance of sharp signals for  $\text{cis-PtA}_2(\text{dGpG})$  cross-link models can be due either to fast exchange of multiple conformers or to one nonexchanging conformer. Therefore, the nature of the dynamic motion of these natural cross-links is unclear, unlike for the artificial cross-linked species studied here. Finally, the novel complex has an advantage over simpler models. The complex provides a new strategy for sampling the rotamer distribution of  $\text{cis-PtA}_2\text{G}_2$  complexes, which atropisomerize too rapidly in the solution phase and inexplicably adopt the  $\Delta$ HT form in the solid phase. Our study has led to the first compelling evidence that, for nonbulky  $\text{A}_2$  ligands, both HT forms of  $\text{cis-PtA}_2\text{G}_2$  exist and are present in an approximately 1:1 mixture.

**Acknowledgment.** A.A.I. is grateful to the King Fahd University of Petroleum and Minerals, Dhahran, Saudi Arabia, for a sabbatical leave during 1997–1998 academic year. This work was supported by NIH Grant GM 29222 (to L.G.M.).

IC980946Y

(23) Kozelka, J.; Fouchet, M.; Chottard, J. *Eur. J. Biochem.* **1992**, *205*, 895.

(24) The La center is chiral also, but all evidence suggests that it is fluxional (cf. ref 21); for the purposes here the center is symmetrical.