

CONTRIBUTION FROM THE DEPARTMENT OF CHEMISTRY,  
MASSACHUSETTS INSTITUTE OF TECHNOLOGY, CAMBRIDGE, MASSACHUSETTS

## Preparation and Spectra of Some Adducts of the Nonachlorotrirhenium and Nonabromotrirhenium Groups; Evidence for the $\text{Re}_3\text{Br}_9$ Group<sup>1</sup>

BY F. A. COTTON, S. J. LIPPARD,<sup>2a,b</sup> AND J. T. MAGUE<sup>2a</sup>

Received December 3, 1964

The preparation and characterization of a series of  $\text{Re}_3\text{Br}_9\text{L}_3$  compounds as well as some new  $\text{Re}_3\text{Cl}_9\text{L}_3$  compounds are described. Several corresponding  $\text{Re}_3\text{Br}_9\text{L}_3$  and  $\text{Re}_3\text{Cl}_9\text{L}_3$  compounds appear to be isomorphous and presumably isostructural, thus indicating that there are similar  $\text{Re}_3\text{X}_9$  groups in both series. Of considerable interest is the fact that the visible spectra of all the compounds, of both series, are very similar. This suggests that the absorption bands are characteristic of the  $\text{Re}_3$  metal atom cluster. It has also been found that sulfoxides and triphenylphosphine oxide are strongly bonded to  $\text{Re}_3\text{X}_9$  groups, which indicates that the centrifugally directed orbitals of the Re atoms are well suited for bonding, but that with bulky ligands steric factors become dominant.

### Introduction

It has recently become clear that there exists an extensive series of Re(III) chloro compounds which are based, structurally,<sup>3-7</sup> on the metal atom cluster species,  $\text{Re}_3\text{Cl}_9$ . Chemically, these compounds are derived from rhenium(III) chloride which is obtained by sublimation and it has been shown that the  $\text{Re}_3\text{Cl}_9$  group is present in this substance.<sup>7</sup> We know of no report that an  $\text{Re}_3\text{Cl}_9$  derivative has been obtained in any other way than more or less directly from sublimed rhenium(III) chloride. On the basis of these facts, the question naturally came to mind whether a similar chemistry of  $\text{Re}_3\text{Br}_9$  might exist, deriving chemically from the well-known form of rhenium(III) bromide which is isolated and purified by sublimation. We have previously demonstrated that there are at least two compounds belonging to this category, *viz.*,  $\text{Re}_3\text{Br}_9\text{[(C}_6\text{H}_5)_2\text{(C}_2\text{H}_5)_2\text{P}]_3$ <sup>8</sup> and  $(\text{quinolinium})_2\text{Re}_3\text{Br}_{15}$ , the latter substance containing  $\text{Re}_3\text{Br}_9$  groups and  $[\text{ReBr}_6]^{2-}$  ions.<sup>8</sup>

In this paper we report a series of compounds of empirical formula  $(\text{ReBr}_3\text{L})_x$  as well as a series of analogous compounds of rhenium(III) chloride (several of which were already known). It is then shown that all of the compounds in both series are certain, or at least very likely, to have molecular formulas  $\text{Re}_3\text{X}_9\text{L}_3$ , based on the  $\text{Re}_3\text{X}_9$  units. Finally, certain spectral features are found to be common to all the known  $\text{Re}_3\text{Br}_9$  compounds and they thus provide a diagnostic test for the presence of this group. The considerable qualitative similarity of the characteristic spectra of the  $\text{Re}_3\text{Cl}_9$  and  $\text{Re}_3\text{Br}_9$  groups suggests that these characteristic features of their spectra are due principally to the  $\text{Re}_3$  clusters present in both groups.

(1) Supported by the United States Atomic Energy Commission.

(2) (a) N.S.F. Predoctoral Fellow; (b) Woodrow Wilson Honorary Fellow, 1962-1963.

(3) J. A. Bertrand, F. A. Cotton, and W. A. Dollase, *J. Am. Chem. Soc.*, **85**, 1349 (1963); *Inorg. Chem.*, **2**, 1106 (1963).(4) W. T. Robinson, J. E. Fergusson, and B. R. Penfold, *Proc. Chem. Soc.*, 116 (1963).(5) J. E. Fergusson, B. R. Penfold, and W. T. Robinson, *Nature*, **201**, 181 (1964).(6) F. A. Cotton and J. T. Mague, *Inorg. Chem.*, **3**, 1094 (1964).(7) F. A. Cotton and J. T. Mague, *ibid.*, **3**, 1402 (1964).(8) F. A. Cotton and S. J. Lippard, *ibid.*, **4**, 59 (1965).

### Experimental

**Rhenium(III) chloride** was obtained from Alfa Inorganics and used as received.

**Rhenium(III) bromide** was prepared according to the following procedure. While the procedure is not new in principle,<sup>9-11</sup> we have found that in order to obtain good yields in the shortest possible time, attention to various experimental details is important. We believe that the following detailed description will be of value to others wishing to prepare anhydrous rhenium(III) bromide as expeditiously as possible. The procedure is based on the following sequence of reactions.

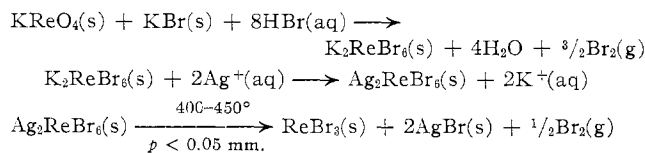

Potassium perrhenate (9.5 g., 0.033 mole) and potassium bromide (3.6 g., 0.03 mole) were powdered and mixed in a mortar and added to 350 ml. of 48% aqueous hydrobromic acid. The mixture was then kept on a steam bath for 6 hr. and the volume maintained by frequent additions of 48% HBr. The liquid was then permitted to evaporate until the volume was reduced to about 50 ml. The deep purple crystals of  $\text{K}_2\text{ReBr}_6$  which had formed were separated by filtration through a fritted glass disk of medium porosity, washed with three 10-ml. portions of cold (*ca.* 0°) 48% HBr, and dried in air; yield, *ca.* 22 g. (90% based on  $\text{KReO}_4$ ). The product was identified by K and Br analyses.

Concentrated nitric acid (100 ml.) was added to 400 ml. of water and 15 g. of silver nitrate dissolved in this liquid. Approximately 22 g. of  $\text{K}_2\text{ReBr}_6$  was then added with rapid stirring. Yellow  $\text{H}_2\text{ReBr}_6$  which first forms is immediately converted into  $\text{Ag}_2\text{ReBr}_6$ . The slurry was stirred for 1 hr. (this may be unnecessary), filtered, and the chocolate-brown solid was then washed with dilute nitric acid and water until the washings contained insufficient silver ion to give a precipitate with dilute HBr. The compound was then thoroughly dried by drawing air through it for several hours; yield, 26 g. (100% based on  $\text{K}_2\text{ReBr}_6$ ).

From the  $\text{Ag}_2\text{ReBr}_6$ , rhenium(III) bromide was prepared in 2-g. portions using the apparatus shown in Figure 1.  $\text{Ag}_2\text{ReBr}_6$  (4.6 g.), finely pulverized, was placed in chamber A. Side arm B was then connected to a vacuum line and the pressure in the apparatus reduced to 0.05 mm. or less. The probe C was then filled with water as shown by the shaded area in Figure 1 and a short tubular furnace, D, slipped over chamber A. This furnace may be a commercially available device or one constructed by

(9) F. Kraus and H. Steinfeld, *Ber.*, **64**, 2552 (1931).(10) W. S. Shüth and W. Klemm, *Z. anorg. allgem. Chem.*, **220**, 193 (1934).(11) J. P. King and J. W. Cobble, *J. Am. Chem. Soc.*, **82**, 2111 (1960).

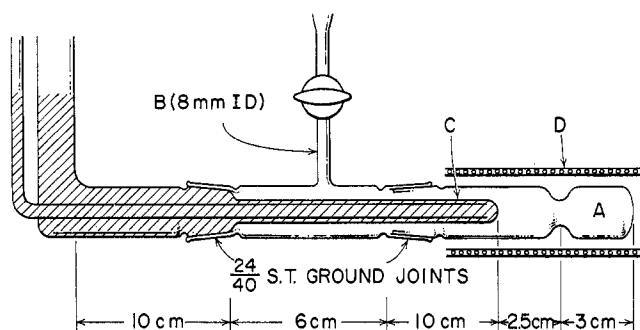

Figure 1.—A sketch of the sublimation apparatus used in preparing approximately 2-g. lots of rhenium(III) bromide. Dimensions are in cm.; other dimensions may be inferred with adequate accuracy by proportion.

wrapping Nichrome wire around a piece of Vycor tubing and fixing it in place with asbestos tape wrapping. The furnace temperature was raised rapidly to  $450^\circ$  and held there for 1 hr. during which time decomposition took place. Bromine was collected in a liquid nitrogen cooled trap placed between side arm B and the vacuum line. Crystalline rhenium(III) bromide formed on the probe C which quickly rose to a temperature of  $100^\circ$ , where it then remained due to vaporization of the water inside the probe. This is intentional and necessary in order that the deposit be free of bromine.

After cooling, the probe is removed and the rhenium(III) bromide scraped off of it. Occasionally some of the product flaked off of the probe during the sublimation, but this is easily removed from the outer vessel using a spatula or brush; yield, 10–11 g. (80–90% based on  $\text{Ag}_2\text{ReBr}_6$ ).

*Anal.* Calcd. for  $\text{ReBr}_3$ : Re, 43.69; Br, 56.31. Found: Re, 42.6; Br, 57.2.

Using the same apparatus, the product may be resublimed to increase its purity, but the material obtained directly has been used in all reactions described below. If instead of filling the probe with water, a slow stream of air is passed through it, the yields of rhenium(III) bromide are lower, but the product consists of larger crystals.

**Tris(triphenylphosphine)nonabromotrirhenium(III).**—Rhenium(III) bromide (0.5 g., 1.2 mmoles) was dissolved in 100 ml. of acetone and an equimolar amount of triphenylphosphine (0.32 g.) added with stirring. No immediate reaction was observed. The solution was permitted to evaporate slowly (*ca.* 3 days) over Drierite (anhydrous  $\text{CaSO}_4$ ) in an evacuated desiccator to a volume of about 20 ml., to yield 0.5 g. (60%) of purple crystals. These were separated by filtration on a fritted glass disk and dried in air, and then under vacuum at  $80^\circ$  for 6 hr.

*Anal.* Calcd. for  $\text{C}_{66}\text{H}_{48}\text{P}_3\text{Re}_3\text{Br}_9$ : C, 31.40; H, 2.18; P, 4.50; Br, 34.88. Found: C, 31.3; H, 2.49; P, 4.35; Br, 34.4.

This compound is insoluble in acetone, ethanol, benzene, and acetonitrile. It does dissolve in dimethyl sulfoxide to give a solution which is initially red but which becomes green within about 2 min. This result is obtained with careful exclusion of oxygen. The color change may be due to the displacement of triphenylphosphine groups by dimethyl sulfoxide groups in the three outer positions of the  $\text{Re}_3\text{Br}_9$  group.

**Tris(triphenylarsine)nonabromotrirhenium(III).**—Rhenium(III) bromide (0.5 g., 1.2 mmoles) was dissolved in 100 ml. of acetone and triphenylarsine (0.37 g.) was added slowly with stirring. Evaporation of the solution to a volume of *ca.* 20 ml. and cooling to  $0^\circ$  failed to give crystals. Diethyl ether (100 ml.) was therefore added and the solution was permitted to evaporate slowly in air for 2 days at  $20$ – $25^\circ$ . Large, purple crystals (some 4 mm. across) were deposited. The crystals were separated by filtration and dried in air and then for 6 hr. at  $80^\circ$  under vacuum; yield, 0.45 g., 52%.

*Anal.* Calcd. for  $\text{C}_{66}\text{H}_{48}\text{As}_3\text{Re}_3\text{Br}_9$ : C, 29.51; H, 2.05; As, 10.23; Br, 32.79. Found: C, 29.8; H, 2.20; As, 10.1; Br, 32.6.

**Tris(diethylphenylphosphine)nonabromotrirhenium(III).**—Rhenium(III) bromide (0.25 g., 0.59 mmole) was dissolved in 100 ml. of acetone and a slight excess of diethylphenylphosphine (0.11 ml, 0.64 mmole) was added. The solution was left to stand for 12 hr. during which time purple crystals (0.15 g., 43%) precipitated. These were separated by filtration, washed with cold acetone, then ether, and dried in air.

*Anal.* Calcd. for  $\text{C}_{30}\text{H}_{46}\text{P}_3\text{Re}_3\text{Br}_9$ : C, 20.34; H, 2.54. Found: C, 20.4; H, 2.44.

**Tris(*p*-tolyl sulfoxide)nonabromotrirhenium(III).**—Rhenium(III) bromide (0.5 g., 1.2 mmoles) was dissolved in 100 ml. of boiling acetone and the volume reduced to 50 ml. on a steam bath. A tenfold excess of *p*-tolyl sulfoxide (2.8 g., 12 mmoles) was dissolved in 15 ml. of acetone to which the cooled acetone solution of  $(\text{ReBr}_3)_n$  was added slowly with stirring. The mixture was then brought to a boil on a steam bath and ether added until the total volume was about 200 ml. The solution was then placed in a refrigerator and permitted to evaporate slowly. Red crystals (0.44 g.; yield, 56% based on  $(\text{ReBr}_3)_n$ ) were collected by filtration after 12 hr. These were washed with ether, a 1:1 mixture of ether and acetone, and again with ether, and dried in air.

*Anal.* Calcd. for  $\text{C}_{42}\text{H}_{42}\text{S}_3\text{O}_3\text{Re}_3\text{Br}_9$ : C, 25.61; H, 2.14; S, 4.88; Br, 36.65. Found: C, 25.9; H, 2.18; S, 4.90; Br, 36.8.

**Tripyridinenonabromotrirhenium(III).**—Rhenium(III) bromide (0.5 g., 1.2 mmoles) was added to 150 ml. of acetone, the solution boiled until the volume was 100 ml., and the hot solution poured through a medium porosity fritted glass disk into a tenfold excess of pyridine (1.0 ml.). As the solution cooled to room temperature, a bright green precipitate formed. This was collected by filtration, washed several times with ether, and dried at  $110^\circ$  under vacuum; yield, 0.40 g. (75%).

*Anal.* Calcd. for  $\text{C}_{18}\text{H}_{18}\text{N}_3\text{Re}_3\text{Br}_9$ : C, 11.88; H, 0.99; N, 2.78; Br, 47.53. Found: C, 11.8; H, 0.99; N, 2.75; Br, 47.2.

**Quinolinium Decabromotrirhenate(III).**—This compound was obtained in the attempt to recrystallize  $(\text{C}_9\text{H}_7\text{N})_2\text{Re}_3\text{Br}_{11}$ , the preparation of which has already been reported,<sup>8</sup> from 48% aqueous HBr. On cooling the solution to ice temperature, the compound is obtained as purple crystals; X-ray examination indicated that these are triclinic and they were not further studied.

*Anal.* Calcd. for  $\text{C}_9\text{H}_7\text{NRe}_3\text{Br}_{10}$ : C, 7.26; H, 0.54. Found: C, 7.28; H, 0.65.

**Tetra(*n*-butyl)ammonium Dodecabromotrirhenate(III).**—The entire preparative procedure was carried out under nitrogen. Rhenium(III) bromide (0.5 g.) was dissolved in 150 ml. of 48% aqueous HBr, which had been purged of oxygen, at reflux temperature. The solution was cooled to  $25^\circ$  and filtered through a fritted glass disk onto a tenfold excess of (*n*- $\text{C}_4\text{H}_9$ )<sub>4</sub>NBr (3.9 g., 0.012 mole). The mixture was vigorously agitated. The color of the solution quickly changed from deep red to deep green and a green solid began to precipitate. Agitation was continued for 12 hr., the solid was collected by filtration and dried under vacuum; yield, 0.4 g. (45% based on  $(\text{ReBr}_3)_n$ ).

*Anal.* Calcd. for  $\text{C}_{48}\text{H}_{108}\text{N}_4\text{Re}_3\text{Br}_{12}$ : C, 25.67; H, 4.81; N, 1.87; Br, 42.78. Found: C, 25.1; H, 4.25; N, 1.65; Br, 43.8.

The dark green powder dissolves readily in methanol, acetonitrile, and acetone to give red solutions. The infrared spectrum of a hydrocarbon mull was essentially identical with that of a mull sample of (*n*- $\text{C}_4\text{H}_9$ )<sub>4</sub>NBr.

**Tris(sulfoxide)nonachlorotrirhenium(III) Complexes.**—These compounds, in which the sulfoxides were *p*-tolyl, benzyl, phenyl, and tetramethylene sulfoxide, were prepared by adding an excess of the sulfoxide dissolved in acetone to an acetone solution of trirhenium(III) nonachloride. The  $\text{Re}_3\text{Cl}_9$  was "solubilized" by grinding it in a mortar, exposing it to moist air, and redrying it under vacuum at  $80^\circ$ . The mixture of acetone solutions was allowed to evaporate slowly to about 20% of its original volume, in air at room temperature, and the precipitated solid compounds were filtered off and dried.

In a typical preparation, 0.5 g. (0.57 mmole) of  $\text{Re}_3\text{Cl}_9$  was dissolved in 30 ml. of hot acetone and to this was added 20 ml. of an acetone solution containing 1.6 g. (6.8 mmoles) of *p*-tolyl sulfide. The brown-red needles which were deposited when this solution stood overnight were collected by filtration, washed with a small amount of cold acetone, and dried under vacuum at  $80^\circ$ .

*Anal.* Calcd. for  $\text{C}_{42}\text{H}_{42}\text{S}_2\text{O}_3\text{Re}_3\text{Cl}_9$ : C, 32.15; H, 2.70; Cl, 20.34. Found for the *p*-tolyl compound: C, 32.0; H, 2.90; Cl, 20.4. Found for the benzyl compound: C, 31.8; H, 2.84. Calcd. for  $\text{C}_{36}\text{H}_{30}\text{S}_2\text{O}_3\text{Re}_3\text{Cl}_9$ : C, 29.11; H, 2.04. Found for the phenyl compound: C, 29.6; H, 2.35. Calcd. for  $\text{C}_{12}\text{H}_9\text{S}_3\text{O}_3\text{Re}_3\text{Cl}_9$ : C, 12.15; H, 2.04. Found for the tetramethylene compound: C, 13.9; H, 2.15.

It is evident from the analytical data that the tetramethylene sulfide complex was slightly contaminated with excess sulfoxide. This was also noticeable in the infrared spectrum by the presence of a small peak at  $1020\text{ cm}^{-1}$ , approximately where the SO stretching mode for uncoordinated  $\text{C}_4\text{H}_8\text{SO}$  occurs. It was found impossible to remove this slight excess of sulfoxide even when pumping was continued for several days.

**Tris(triphenylphosphine oxide)nonachlorotrirhenium(III).**—

This compound was made by a modification of the procedure of Johnson, Lock, and Wilkinson.<sup>12</sup> A solution of 0.5 g. of  $\text{Re}_3\text{Cl}_9$  in 25 ml. of acetone was added to a boiling solution of 1 g. (0.0036 mole) of  $(\text{C}_6\text{H}_5)_3\text{PO}$  in 25 ml. of acetone. The solution was allowed to cool and 25 ml. of diethyl ether was added. Upon evaporating the solution in air at room temperature to about one-half its original volume, a red microcrystalline precipitate formed. This was separated by filtration and dried under vacuum at  $80^\circ$ .

*Anal.* Calcd. for  $\text{C}_{64}\text{H}_{48}\text{P}_3\text{O}_3\text{Re}_3\text{Cl}_9$ : C, 37.86; H, 2.65. Found: C, 37.5; H, 2.49.

Great difficulty was encountered in the preparation of this compound. The previous workers report that the compound precipitates immediately upon addition of the  $\text{Re}_3\text{Cl}_9$  to the triphenylphosphine oxide, but this was never observed to happen. Subsequent evaporation of most of the solvent was always necessary to obtain any solid product using their method. The composition of these products always varied although it generally approximated that for two triphenylphosphine oxide molecules per  $\text{Re}_3\text{Cl}_9$  unit.

**Other Derivatives of  $\text{Re}_3\text{Cl}_9$ .**—The directions given in the literature were used for the preparation of the tris complexes containing phenyldiethylphosphine,<sup>13</sup> triphenylphosphine,<sup>13,14</sup> and pyridine.<sup>14</sup> It was found necessary to pump the pyridine compound for several hours to remove completely excess pyridine.

*Anal.* Calcd. for  $\text{C}_{16}\text{H}_{15}\text{N}_3\text{Re}_3\text{Cl}_9$ : C, 16.15; H, 1.36; N, 3.77. Found: C, 16.2; H, 1.56; N, 3.69.

**Tetraphenylarsoniumundecachlorotrirhenate(III)** was prepared by adding 0.14 g. (0.34 mmole) of  $(\text{C}_6\text{H}_5)_4\text{AsCl}$  to a solution of 0.1 g. (0.11 mmole) of  $\text{Re}_3\text{Cl}_9$  in acetone (30 ml.). A fine, red precipitate quickly formed, which was collected by filtration and dried under vacuum at  $80^\circ$ .

*Anal.* Calcd. for  $\text{C}_{48}\text{H}_{40}\text{As}_2\text{Re}_3\text{Cl}_{11}$ : C, 33.60; H, 2.35. Found: C, 33.8; H, 2.35.

## Results

**X-Ray Data.**—As we have mentioned several times previously,<sup>6</sup> tris(phenyldiethylphosphine)nonabromotrirhenium is isomorphous with its chloro analog and thus, presumably, has the same molecular structure.<sup>6</sup> The evidence for this is the X-ray powder diffraction pattern of  $\text{Re}_3\text{Br}_9[(\text{C}_2\text{H}_5)_2(\text{C}_6\text{H}_5)\text{P}]_3$ , taken with nickel-filtered copper radiation. The pattern was indexed using a cubic unit cell with  $a_0 = 20.82\text{ \AA}$ . (*cf.*  $a_0 = 20.53\text{ \AA}$ . for the chloro compound<sup>6</sup>). The systematic

TABLE I  
X-RAY POWDER DIFFRACTION DATA AND INDEXING FOR  
 $[(\text{C}_6\text{H}_5)(\text{C}_2\text{H}_5)_2\text{PReBr}_3]_3$

Obsd.	Interplanar spacings, $\text{\AA}$ .		Indices
	Calcd. for cubic cell, $a_0 = 20.82$		
10.41	10.43		200
9.40	9.32		210
8.57	8.52		211
7.38	7.37		220
6.95	6.95		221
5.80	5.78		320
5.55	5.57		321
5.21	5.21		400
5.04	5.06		410, 322
4.88	4.91		411, 330
4.76	4.78		331
4.56	4.55		421
4.43	4.44		332
4.26	4.26		422
4.02	4.02		511, 333
3.86	3.88		520, 432
3.60	3.58		530, 433
3.47	3.48		600, 442
3.39	3.38		611, 532
3.25	3.25		621, 540, 443
3.17	3.18		533

absence  $h00$ ,  $h \neq 2n$ , required by the space group  $\text{Pa}\bar{3}$ , was not violated. The observed reflections and their indexing are listed in Table I. In addition, the relative intensities of the lines in the patterns for the bromo and chloro compounds are very similar, though not exactly the same.

Powder diffraction patterns for the three compounds  $\text{Re}_3\text{Cl}_9[(\text{C}_6\text{H}_5)_3\text{P}]_3$ ,  $\text{Re}_3\text{Br}_9[(\text{C}_6\text{H}_5)_3\text{P}]_3$ , and  $\text{Re}_3\text{Br}_9[(\text{C}_6\text{H}_5)_3\text{As}]_3$  are nearly identical in relative line positions (see Table II) and relative intensities. The isomorphism and, consequently, the occurrence of analogous molecular structures in all three compounds is thus strongly implied. Similarly, powder diffraction patterns (Table II) of  $\text{Re}_3\text{Cl}_9[(p\text{-CH}_3\text{C}_6\text{H}_4)_2\text{SO}]_3$  and  $\text{Re}_3\text{Br}_9[(p\text{-CH}_3\text{C}_6\text{H}_4)_2\text{SO}]_3$  are similar enough to indicate that they are isomorphous. Unfortunately,  $\text{Re}_3\text{Cl}_9(\text{C}_6\text{H}_5\text{N})_3$  was obtained only in the form of particles too fine to give a useful powder diffraction pattern.

All crystals of rhenium(III) bromide which were examined (about 30) were found to be twinned along a plane parallel to the  $b$  axis. Most were black rhombs; a few were needles, elongated along  $b$ . The unit cell was found to be monoclinic with the dimensions  $a = 8.10$ ,  $b = 10.62$ ,  $c = 8.65\text{ \AA}$ ;  $\beta = 111^\circ$ . The systematic absence,  $0k0$  for  $k \neq 2n$ , indicates the space groups  $\text{P}2_1$  or  $\text{P}2_1/\text{m}$ . The density,  $6.13 \pm 0.05\text{ g. cm}^{-3}$ , measured by displacement of cyclohexane, indicates that there are six  $\text{ReBr}_3$  units per cell. All of these results are in agreement with the work of Gelinek and Rüdorff.<sup>15</sup>

**Visible Spectra.**—The visible spectra of all of the compounds are summarized in Table III. Figure 2 shows the spectra for most of the  $\text{Re}_3\text{Br}_9$  derivatives, while Figure 3 gives a direct comparison of the spectra of analogous  $\text{Re}_3\text{Br}_9\text{L}_3$  and  $\text{Re}_3\text{Cl}_9\text{L}_3$  compounds.

(12) N. P. Johnson, C. J. L. Lock, and G. Wilkinson, *J. Chem. Soc.*, 1054 (1964).

(13) J. Chatt and G. A. Rowe, *ibid.*, 4019 (1962).

(14) R. Colton, R. Levitus, and G. Wilkinson, *ibid.*, 4121 (1960).

(15) J. Gelinek and W. Rüdorff, *Naturwissenschaften*, **51**, 85 (1964).

TABLE II  
 INTERPLANAR SPACINGS (Å.) IN GROUPS OF ISOMORPHOUS  $\text{Re}_3\text{Cl}_9\text{L}_3$  AND  $\text{Re}_3\text{Br}_9\text{L}_3$  COMPOUNDS<sup>a</sup>

$\text{Re}_3\text{Cl}_9[\text{P}(\text{C}_6\text{H}_5)_3]_3$	$\text{Re}_3\text{Br}_9[\text{P}(\text{C}_6\text{H}_5)_3]_3$	$\text{Re}_3\text{Br}_9[\text{As}(\text{C}_6\text{H}_5)_3]_3$	$\text{Re}_3\text{Cl}_9[(p\text{-tolyl})_2\text{SO}]_3$	$\text{Re}_3\text{Br}_9[(p\text{-tolyl})_2\text{SO}]_3$
12.20 s	13.92 w	14.20 m	10.79 vs	10.88 s
10.28 vs	12.24 s	12.28 s	9.59 vs	9.83 s
9.64 vs	10.28 vs	10.37 vs	9.29 vs	9.17 s
8.91 s	9.67 vs	9.83 vs	8.53 m	8.76 m
8.29 m	8.96 s	9.05 s		7.70 w
7.82 s	8.39 w	8.49 m	7.27 m	7.35 m
7.13 m	7.87 m	7.88 m	6.72 m	6.88 w
6.40 s	7.26 m	7.32 m	6.01 s	6.11 m
5.86 w	6.43 m	6.54 s	5.77 w	
5.59 m	6.05 w	5.97 w		5.41 w
5.39 m	5.67 w		5.19 s	5.25 m
5.19 m	... <sup>b</sup>	5.22 w	4.76 vw	4.89 vw
4.75 m		4.88 w	4.50 vw	
4.45 w		4.58 w	4.07 w	
4.16 w			3.95 w	4.05 vw
4.05 vw			3.56 vw	3.62 w
3.95 m			3.36 vw	
3.63 vw		3.65 w	3.17 w	3.24 w
3.57 vw			3.05 w	3.10 w
3.43 vw		3.49 m		
3.26 vw		3.30 m		
3.19 vw		3.20 m		
2.98 s	3.02 m	3.05 m		

<sup>a</sup> Spacings in Ångstroms; diffraction patterns recorded with Ni-filtered Cu radiation; relative intensities are given using the symbols v, very; s, strong; m, medium; w, weak. <sup>b</sup> A number of lines evidently occur between  $d$  values of 5.50 and 3.20 Å., but they were too weak and diffuse to permit meaningful measurement.

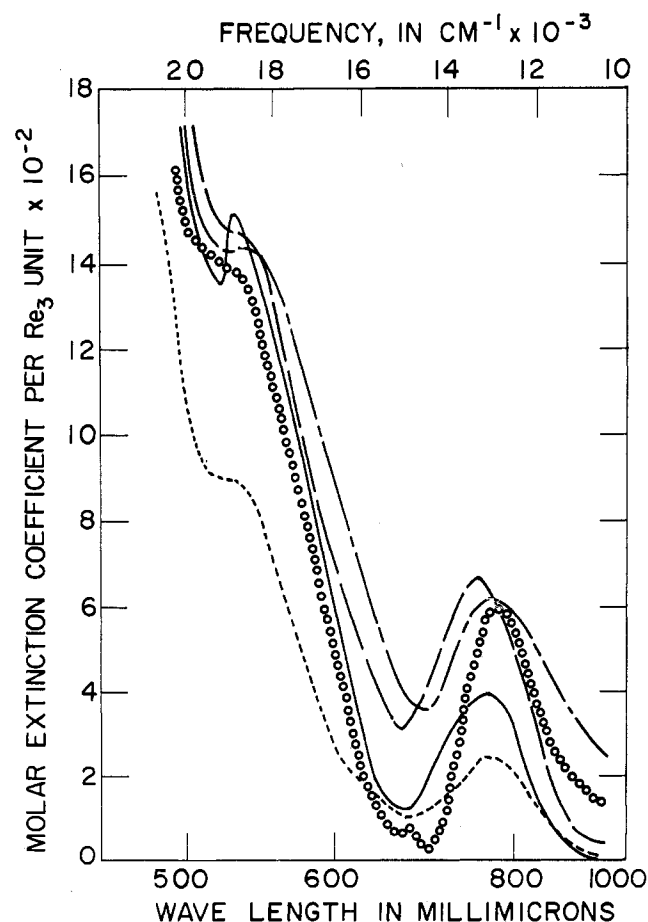

Figure 2.—The visible spectra of solutions of rhenium(III) bromide and several of its derivatives. See also Figure 3.  $(\text{ReBr}_3)_n$  in 48% HBr (—);  $(\text{ReBr}_3)_n$  in acetone (---);  $(\text{C}_6\text{H}_5\text{N})_2\text{Re}_3\text{Br}_9$  in acetone (○○○);  $(\text{C}_9\text{H}_7\text{N})_2\text{Re}_3\text{Br}_9$  in 48% aqueous HBr (— · —);  $[\text{ReBr}_3(\text{C}_6\text{H}_5)_3\text{As}]_3$  in acetone (· · · ·).

**Infrared Spectra.**—The infrared spectra of the sulfide and phosphine oxide complexes have been recorded and compared with those of the uncoordinated ligands. The only important shifts are in the SO and PO stretching frequencies. These are summarized in Table IV.

### Discussion

**Preparation of Compounds.**—All of the preparative methods consist, in principle, of simply mixing rhenium(III) bromide in an appropriate solvent with the ligand, or a solution thereof. Thus, the means and conditions of preparation are entirely consistent with the main thesis of this paper, namely, that rhenium(III) bromide contains  $\text{Re}_3\text{Br}_9$  groups which combine directly with ligands, neutral or ionic (*e.g.*,  $\text{Br}^-$ ), to form  $\text{Re}_3\text{Br}_9\text{L}_n$  compounds, in which  $n$  may be equal to 3, or less. In general,  $n$  has the value 3, but when the ligand is  $\text{Br}^-$ , compounds with  $n = 1, 2, \text{ or } 3$  are now known.<sup>15a</sup> In the analogous system of chloro compounds, only those with  $n = 2$  and 3 have been reported so far.

The circumstances determining which of the ions  $[\text{Re}_3\text{Br}_{10}]^-$ ,  $[\text{Re}_3\text{Br}_{11}]^{2-}$ , or  $[\text{Re}_3\text{Br}_{12}]^{3-}$  is precipitated are not yet clearly understood. Even with the largest possible excess of quinolinium bromide in 48% HBr, the  $[\text{Re}_3\text{Br}_{11}]^{2-}$  compound is obtained, but from solutions with lower concentrations of quinolinium bromide, including the solution obtained when  $(\text{C}_9\text{H}_7\text{N})_2[\text{Re}_3\text{Br}_{11}]$  is recrystallized from 48% HBr, the  $[\text{Re}_3\text{Br}_{10}]^-$  salt is obtained. The preparation of two other  $[\text{Re}_3\text{Br}_{10}]^-$

(15a) NOTE ADDED IN PROOF.—The compounds  $(\text{C}_6\text{H}_5)_4\text{NRe}_3\text{Br}_{10}$  and  $[(n\text{-C}_4\text{H}_9)_4\text{N}]_2\text{Re}_3\text{Br}_{11}$  have been prepared and characterized since this paper was submitted. Their spectral and other properties are consistent with those of the  $\text{Re}_3\text{Br}_9\text{L}_n$  complexes reported herein.

TABLE III  
ELECTRONIC ABSORPTION SPECTRA OF  $\text{Re}_3\text{Br}_9$   
AND  $\text{Re}_3\text{Cl}_9$  COMPOUNDS

Compound	Solvent	$\nu_{\text{max}}$ , $\text{cm}^{-1}$	$\epsilon^a$	
(a) Bromo Compounds				
$(\text{ReBr}_3)_n$	Aq. 48% HBr	13,100	390	
		18,900	sh	
		22,200	4,020	
		25,600	7,260	
$(\text{ReBr}_3)_n$	Acetone	30,300	9,300	
		13,400	660	
		18,700	sh	
		22,100	5,100	
		25,600	8,000	
$\text{Re}_3\text{Br}_9[(\text{C}_2\text{H}_5)_2(\text{C}_6\text{H}_5)\text{P}]_3$	$\text{CHCl}_3$	12,600	600	
		17,900	sh	
		24,700	11,000	
		29,400	15,000	
$\text{Re}_3\text{Br}_9[(\text{C}_6\text{H}_5)_3\text{As}]_3$	Acetone	13,000	255	
		19,100	sh	
		22,000	>3,000	
$\text{Re}_3\text{Br}_9[(p\text{-CH}_3\text{C}_6\text{H}_4)_2\text{SO}]_3$	Acetone	13,300	722	
		19,200	sh	
		22,000	6,000	
$\text{Re}_3\text{Br}_9(\text{C}_6\text{H}_5\text{N})_3$	Reflectance	11,380	...	
$[(n\text{-C}_4\text{H}_9)_4\text{N}]_3\text{Re}_3\text{Br}_{12}$	Reflectance	$\sim 19,000$	br	
		$\sim 19,000$	br	
$(\text{C}_6\text{H}_5\text{N})_2\text{Re}_3\text{Br}_{11}$	Acetone	12,900	606	
		18,700	sh	
$\text{Re}_3\text{Br}_9$ , in $(\text{C}_9\text{H}_8\text{N})_2\text{-Re}_4\text{Br}_{15}$	Mull	$\sim 12,700$	...	
		$\sim 17,900$	sh	
		21,300	...	
		22,700	...	
(b) Chloro Compounds				
$\text{Re}_3\text{Cl}_9[(p\text{-CH}_3\text{C}_6\text{H}_4)_2\text{SO}]_3$	Acetone	13,100	480	
		19,400	1,230	
		12,900	590	
$\text{Re}_3\text{Cl}_9[(\text{C}_6\text{H}_5\text{CH}_2)_2\text{SO}]_3$	Acetone	19,600	1,610	
		22,250	790 sh	
		13,300	500	
		19,600	1,600	
$\text{Re}_3\text{Cl}_9[(\text{C}_6\text{H}_5)_2\text{SO}]_3$	Acetone	22,250	850 sh	
		13,300	480	
		19,400	1,420	
$\text{Re}_3\text{Cl}_9[(\text{C}_6\text{H}_5)_3\text{P}]_3$	Acetone	22,300	750 sh	
		13,000	490	
		19,200	1,960	
$\text{Re}_3\text{Cl}_9[(\text{C}_6\text{H}_5)_3\text{PO}]_3$	Acetone	22,800	1,290 sh	
		13,400	700	
		19,600	2,500	
$[(\text{C}_6\text{H}_5)_4\text{As}]_2[\text{Re}_3\text{Cl}_{11}]$	Methanol <sup>b</sup>	22,300	1,480	
		19,800	1,400	
		DMF <sup>b, c</sup>	19,800	1,800
		$\text{CH}_3\text{NO}_2$	12,700	150
$\text{Re}_3\text{Cl}_9(\text{C}_6\text{H}_5\text{N})_3$	$\text{CH}_3\text{NO}_2$	19,100	990	
		12,500	440	
		19,400	829	
		DMF <sup>c</sup>	11,800	680
$\text{Re}_3\text{Cl}_9$	$\text{CH}_3\text{NO}_2$	16,400	1,300	
		11,300	120	
		18,500	860	
		DMF <sup>c</sup>	13,100	540
		19,400	1,700	

<sup>a</sup> Unknown for reflectance spectra. <sup>b</sup> Solubility too low to permit reliable measurement of band expected at  $\sim 13,000 \text{ cm}^{-1}$ .  
<sup>c</sup> DMF = dimethylformamide.

TABLE IV  
SO AND PO STRETCHING FREQUENCIES<sup>a</sup>

Compound	SO or PO freq.	Freq. in free ligand	Shift
$\text{Re}_3\text{Cl}_9[(\text{C}_6\text{H}_5\text{CH}_2)_2\text{SO}]_3$	935	1028	-93
$\text{Re}_3\text{Cl}_9[(p\text{-CH}_3\text{C}_6\text{H}_4)_2\text{SO}]_3$	$\sim 940^b$	1032	-92
$\text{Re}_3\text{Br}_9[(p\text{-CH}_3\text{C}_6\text{H}_4)_2\text{SO}]_3$	$\sim 935^b$	1032	-97
$\text{Re}_3\text{Cl}_9[(\text{C}_6\text{H}_5)_2\text{SO}]_3$	936	1025	-89
$\text{Re}_3\text{Cl}_9[(\text{CH}_2)_4\text{SO}]_3$	910	1015	-105
$\text{Re}_3\text{Cl}_9[(\text{C}_6\text{H}_5)_3\text{PO}]_3$	1127	1195	-68

<sup>a</sup> All measurements were made on solid compounds as mineral oil mulls and on liquids as films between rock salt plates. Frequencies are all in  $\text{cm}^{-1}$ . <sup>b</sup> These bands are very broad and the frequencies given are uncertain by perhaps  $\pm 10 \text{ cm}^{-1}$  for this reason alone.

salts with the cations  $[(\text{C}_6\text{H}_5)_3\text{PH}]^+$  and  $\text{Cs}^+$  has recently been briefly reported.<sup>15a,16</sup> The  $[\text{Re}_3\text{Br}_{11}]^{2-}$  ion has been reported in our earlier paper.<sup>8,15a</sup> The  $[\text{Re}_3\text{Br}_{12}]^{3-}$  ion is described here for the first time.

**X-Ray Structural Evidence.**—The general occurrence of the  $\text{Re}_3\text{Br}_9$  group in compounds prepared by direct addition of ligands to rhenium(III) bromide receives strong support from the isomorphism of several  $(\text{ReBr}_3\text{L})_n$  compounds with their  $(\text{ReCl}_3\text{L})_n$  analogs, for which  $n$  is known to be 3, with the trimeric structure being based on the cyclic  $\text{Re}_3\text{Cl}_9$  group. The case in which L is  $(\text{C}_2\text{H}_5)_2(\text{C}_6\text{H}_5)\text{P}$  is the strongest, since here the structure of the chloro compound has been directly determined.<sup>6</sup> For the compounds in which L is  $(\text{C}_6\text{H}_5)_3\text{P}$ ,  $(\text{C}_6\text{H}_5)_3\text{As}$ , and  $(p\text{-CH}_3\text{C}_6\text{H}_4)_2\text{SO}$ , the argument is less direct and conclusive in the sense that the structures of the corresponding chloro compounds have not been proved directly by a single crystal X-ray structure determination. However, the spectroscopic and chemical evidence to show that these and many other  $(\text{ReCl}_3\text{L})_n$  compounds are derived from  $\text{Re}_3\text{Cl}_9$  is quite strong,<sup>7</sup> even if not absolute. Thus, for the four  $(\text{ReBr}_3\text{L})_n$  compounds, in which L is  $(\text{C}_2\text{H}_5)_2(\text{C}_6\text{H}_5)\text{P}$ ,  $(\text{C}_6\text{H}_5)_3\text{P}$ ,  $(\text{C}_6\text{H}_5)_3\text{As}$ , and  $(p\text{-CH}_3\text{C}_6\text{H}_4)_2\text{SO}$ , there is good evidence from X-ray powder patterns that they are properly formulated as  $\text{Re}_3\text{Br}_9\text{L}_3$ .

It has already been shown<sup>8</sup> by a single crystal X-ray study that the  $\text{Re}_3\text{Br}_9$  group, isostructural with the  $\text{Re}_3\text{Cl}_9$  group, occurs in  $(\text{C}_9\text{H}_8\text{N})_2\text{Re}_4\text{Br}_{15}$ . Our intention had been to proceed with a single crystal X-ray study of rhenium(III) bromide itself, but this has been terminated since Professor W. Rüdorff of Tübingen University informed us privately that his work had reached the stage of providing an unrefined but definite set of atom positions. Our data on the crystals of the bromide are in satisfactory agreement with Rüdorff's,<sup>15</sup> although there was a discrepancy in the case of the chloride. Professor Rüdorff has stated that the structure of the bromide appears to be built of  $\text{Re}_3\text{Br}_9$  units quite similar to the  $\text{Re}_3\text{Cl}_9$  unit.

**Electronic Absorption Spectra.**—Table III records all data on the electronic absorption spectra of rhenium(III) bromide derivatives and new data on  $\text{Re}_3\text{Cl}_9$  compounds. Inspection of these data, together with data for a number of other  $\text{Re}_3\text{Cl}_9$  compounds previously

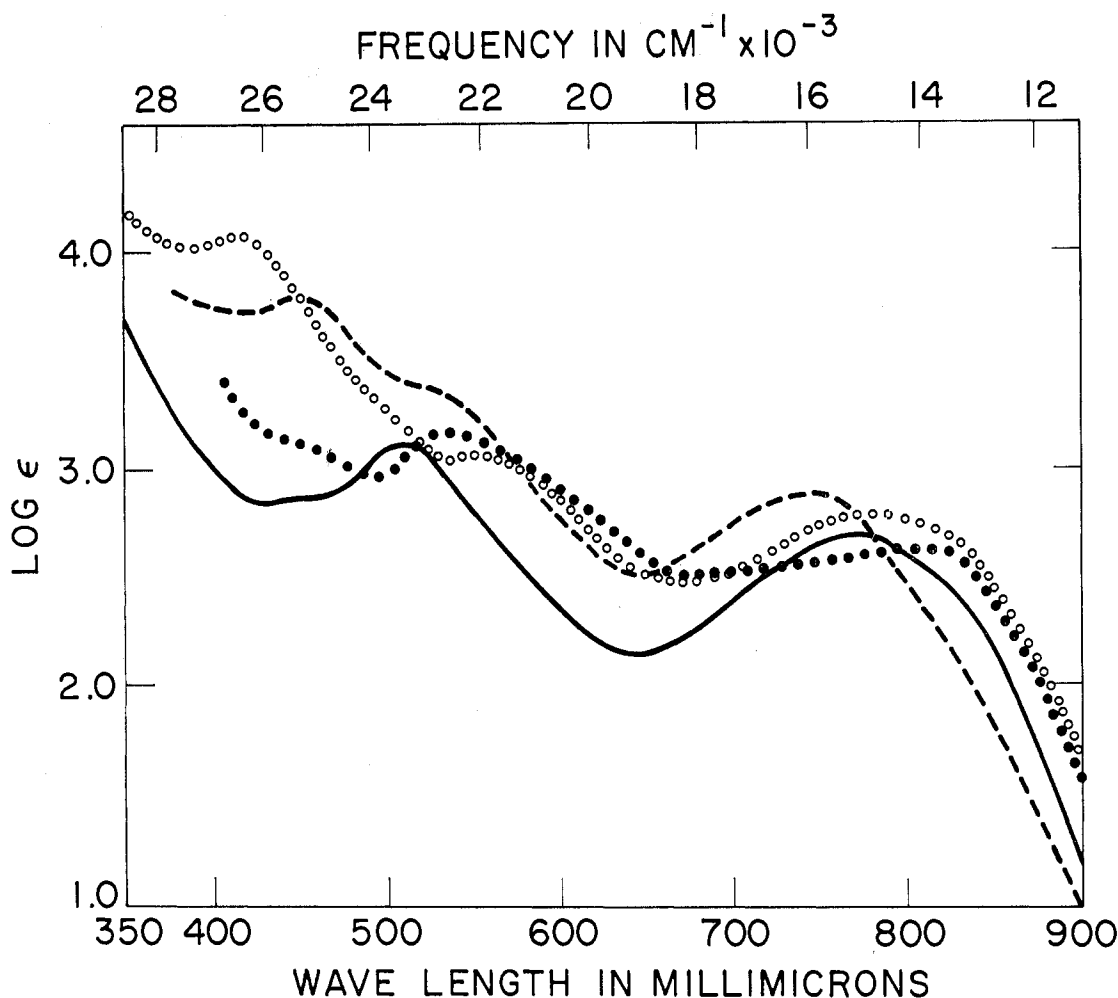

Figure 3.—The spectra of two pairs of analogous  $\text{Re}_3\text{Cl}_9\text{L}_3$  and  $\text{Re}_3\text{Br}_9\text{L}_3$  compounds: full line,  $\text{Re}_3\text{Cl}_9[(p\text{-CH}_3\text{C}_6\text{H}_4)_2\text{SO}]_3$ ; dashed line,  $\text{Re}_3\text{Br}_9[(p\text{-CH}_3\text{C}_6\text{H}_4)_2\text{SO}]_3$ ; filled circles,  $\text{Re}_3\text{Cl}_9[(\text{C}_2\text{H}_5)_2(\text{C}_6\text{H}_5)\text{P}]_3$ ; open circles,  $\text{Re}_3\text{Br}_9[(\text{C}_2\text{H}_5)_2(\text{C}_6\text{H}_5)\text{P}]_3$ .

reported,<sup>7</sup> reveals two important points: (1) The spectra of all of the bromo compounds are quite similar; this is clearly evident in Figure 2, which illustrates a number of these spectra. (2) The spectra of corresponding chloro and bromo compounds are similar; this is illustrated by the two pairs of spectra shown in Figure 3.

Since the list of bromo compounds having very similar spectra includes a number which are known with varying degrees of certainty to contain  $\text{Re}_3\text{Br}_9$  groups, it may be concluded that all of the compounds must contain this group unless some rather remarkably coincidental similarities are to be assumed.

The similarity of the spectra of the bromo and chloro compounds is particularly striking in the two lowest energy bands, occurring at  $\sim 12,500\text{ cm}^{-1}$  with  $\epsilon$  values of  $500 \pm 200$  in both series and at  $\sim 18,500\text{ cm}^{-1}$ , with the  $\epsilon$  values difficult to assess meaningfully for the bromo compounds because of the superposed low energy wing of a stronger near-ultraviolet band. It seems reasonable to conclude that this similarity exists because these absorption bands—and perhaps others—are due to transitions which are localized in the group of atoms common to both  $\text{Re}_3\text{Cl}_9$  and  $\text{Re}_3\text{Br}_9$ , *viz.*, the  $\text{Re}_3$  metal atom cluster.

**Infrared Spectra.**—Qualitatively, these results show that the sulfoxides are bound to the rhenium atoms through oxygen.<sup>17-19</sup> Thus, although the metal atoms here are from the third transition series, they behave as class (a) rather than class (b) acceptors<sup>20</sup> toward sulfoxides. This has also been found for the molybdenum atoms in the  $[\text{Mo}_6\text{Cl}_8]^{4+}$  group,<sup>21</sup> and  $\text{Pd}^{2+}$  and  $\text{Pt}^{2+}$  remain the only acceptors so far found<sup>17-19</sup> to bind sulfoxides through sulfur.

Quantitatively, the data in Table IV are significant in showing that the rhenium atoms in the  $\text{Re}_3\text{X}_9$  groups bind the sulfoxides and the phosphine oxide quite strongly. The average downshift of the SO frequency in the five sulfoxide complexes is  $95\text{ cm}^{-1}$ . This may be compared with shifts found<sup>18</sup> in some other complexes of  $(\text{CH}_2)_4\text{SO}$ , which ranged from  $40$  to  $73\text{ cm}^{-1}$ , the largest shift being for a  $\text{Cu}(\text{II})$  complex. Similarly, for some  $(\text{C}_6\text{H}_5)_2\text{SO}$  complexes of  $\text{Co}(\text{II})$  and  $\text{Ni}(\text{II})$ , downshifts of  $50$ – $60\text{ cm}^{-1}$  were found.<sup>19</sup> It is, of course, necessary to make allowances for the mass difference

(17) F. A. Cotton, R. Francis, and W. D. Horrocks, *J. Phys. Chem.*, **64**, 1534 (1960).

(18) R. Francis and F. A. Cotton, *J. Chem. Soc.*, 2078 (1961).

(19) R. Francis, Ph.D. Thesis, Massachusetts Institute of Technology 1964.

(20) S. Ahrland, J. Chatt, and N. R. Davies, *Quart. Rev. (London)*, **12**, 256 (1958).

(21) F. A. Cotton and N. F. Curtis, *Inorg. Chem.*, **4**, 241 (1965)

between the Co, Ni, and Cu atoms on the one hand and Re on the other. Treating the M-O-S group as a linear system without an interaction constant and taking  $k_{MO}$  to be as high as 2.0 mdynes/Å., it is found that at most about 18 cm.<sup>-1</sup> of the greater downshifts found in the Re<sub>3</sub>X<sub>9</sub> complexes must be attributed to a pure mass effect. This gives a corrected downshift of ~77 cm.<sup>-1</sup> to be compared with the ranges of 40–73 cm.<sup>-1</sup> for the Co(II), Ni(II), and Cu(II) complexes. The downshift of the PO frequency in Re<sub>3</sub>Cl<sub>9</sub>[(C<sub>6</sub>H<sub>5</sub>)<sub>3</sub>PO]<sub>3</sub>, 68 cm.<sup>-1</sup>, when lessened by 14 cm.<sup>-1</sup> to allow for metal atom mass differences, becomes 54 cm.<sup>-1</sup>, which may be compared with downshifts<sup>22</sup> of 40–61 cm.<sup>-1</sup> for (C<sub>6</sub>H<sub>5</sub>)<sub>3</sub>PO complexes of the ions Co(II), Ni(II), Cu(II), and Zn(II). It therefore appears that ligands of the sulfoxide and phosphine oxide types are held at least as strongly by

(22) F. A. Cotton, R. D. Barnes, and E. Bannister, *J. Chem. Soc.*, 2199 (1960).

the Re<sub>3</sub>X<sub>9</sub> groups as by the divalent metal ions toward the end of the first transition series.

In [Re<sub>3</sub>Cl<sub>12</sub>]<sup>3-</sup> and Re<sub>3</sub>Cl<sub>9</sub>[(C<sub>2</sub>H<sub>5</sub>)<sub>2</sub>(C<sub>6</sub>H<sub>5</sub>)P]<sub>3</sub>, it has been found that the bonds from the rhenium atoms to the three nonbridging in-plane chlorine atoms and to the phosphorus atoms were longer, by ~0.13 and ~0.3 Å., respectively, than the "normal" single bond distances.<sup>6</sup> It was suggested that steric effects were at least partly responsible for this, perhaps abetted by an inherently low ability of the centrifugally directed orbitals of rhenium to form bonds. For the O-bonded sulfoxides and the phosphine oxide, the steric effect is small. Therefore, the indication from the large downshifts in the SO and PO stretching frequencies is that there is not in fact any inherent inability of the centrifugally directed orbitals to form bonds with donor atoms and that the unusual lengths of the bonds which have been observed are entirely due to steric factors.

CONTRIBUTION FROM CHEMICAL LABORATORY IV, DEPARTMENT FOR PHYSICAL CHEMISTRY, H. C. ØRSTED INSTITUTE, THE UNIVERSITY OF COPENHAGEN, COPENHAGEN, DENMARK

## Polarized Spectra of Tetracyano Nickelate Crystals

By C. J. BALLHAUSEN, N. BJERRUM, R. DINGLE, KLAAS ERIKS, AND C. R. HARE

Received October 19, 1964

Polarized electronic absorption spectra of different crystals containing Ni(CN)<sub>4</sub><sup>2-</sup> have been obtained. The electronic spectrum consists of a very weak band at 20,000 cm.<sup>-1</sup>, a broad parallel band at 23,000 cm.<sup>-1</sup>, and a band seen both parallel and perpendicular at 27,000 cm.<sup>-1</sup>. With Ba<sup>2+</sup> as cation an additional band is seen at 22,000 cm.<sup>-1</sup>. In addition, two peaks have been observed at ~5600 and ~7000 cm.<sup>-1</sup>. However, these latter are associated with the vibrational properties of the complex. The ground state of the molecule possesses a square-planar configuration, but in order to interpret the electronic spectrum, it is proposed that the observed transitions terminate on potential surfaces where the stable conformation of the molecule is that of a distorted tetrahedron. This hypothesis is strongly supported by semiquantitative considerations.

### Introduction

The electronic structure of the square-planar nickel(II) cyanide complex has been considered by many authors.<sup>1-4</sup> In order to try to settle some of the outstanding questions we have studied the absorption spectra of various crystals containing the Ni(CN)<sub>4</sub><sup>2-</sup> unit.

### Experimental

We have in this investigation examined the following crystals: K<sub>2</sub>Ni(CN)<sub>4</sub>·H<sub>2</sub>O, Na<sub>2</sub>Ni(CN)<sub>4</sub>·3H<sub>2</sub>O, CaNi(CN)<sub>4</sub>·5H<sub>2</sub>O, SrNi(CN)<sub>4</sub>·5H<sub>2</sub>O, and BaNi(CN)<sub>4</sub>·4H<sub>2</sub>O.

The crystal spectra were obtained using a Cary Model 14 spectrophotometer. Two methods were used. The first utilized the Cary in its normal arrangement but with the crystal mounted on the cold finger of a liquid nitrogen cryostat that is constructed so that it fits into the sample compartment of the Cary. The

light emergent from the Cary is polarized by a Glan-Thompson polarizer placed immediately before the crystal (a second polarizer is mounted in the reference beam and is rotated in phase with that in the sample beam).

The second method employs a reflecting microscope mounted in place of the cell compartment (using the infrared optical path) and thus allows spectra of very small crystals to be obtained. A cryostat, similar to that described by Ferguson and Wignall,<sup>5</sup> has been used to cool the crystals to near the temperature of liquid nitrogen.

Spectra have been taken in the extinction directions parallel and perpendicular to the *c* axis of the crystals.

### The Crystal Spectra

The crystal structures of the complexes have been reported by Brasseur and de Rassenfosse<sup>6-7</sup> and Lambot<sup>8</sup> in the early forties. However, the *R* values calculated from some of their data leave much to be

(1) J. R. Perumareddi, A. D. Liehr, and A. W. Adamson, *J. Am. Chem. Soc.*, **85**, 249 (1963).

(2) H. B. Gray and C. J. Ballhausen, *ibid.*, **85**, 260 (1963).

(3) M. Bán and E. Horváth, *Acta Phys. et Chem. Szeged*, **5**, 34 (1959).

(4) S. Kida, J. Fujita, K. Nakamoto, and R. Tsuchida, *Bull. Chem. Soc. Japan*, **31**, 79 (1958).

(5) J. Ferguson and T. F. Wignall, *Spectrochim. Acta*, **15**, 1127 (1959).

(6) H. Brasseur and A. de Rassenfosse, *Bull. soc. franc. mineral.*, **61**, 129 (1938).

(7) H. Brasseur and A. de Rassenfosse, *Mem. soc. roy. sci. Liege*, **4**, 397 (1943).

(8) H. Lambot, *Bull. soc. roy. sci. Liege*, **12**, 533 (1943).