

Self-Assembly in Palladium(II) and Platinum(II) Chemistry: The Biomimetic Approach

Zengquan Qin, Michael C. Jennings, and Richard J. Puddephatt*

Department of Chemistry, University of Western Ontario, London, Canada N6A 5B7

Received May 7, 2002

The self-assembly of complex cationic structures by combination of cis-blocked square planar palladium(II) or platinum(II) units with bis(pyridyl) ligands having bridging amide units has been investigated. The reactions have yielded dimers, molecular triangles, and polymers depending primarily on the geometry of the bis(pyridyl) ligand. In many cases, the molecular units are further organized in the solid state through hydrogen bonding between amide units or between amide units and anions. The molecular triangle $[\text{Pt}_3(\text{bu}_2\text{bipy})_3(\mu-1)]^{6+}$, $\text{M} = \text{Pd}$ or Pt , $\text{bu}_2\text{bipy} = 4,4'$ -di-*tert*-butyl-2,2'-bipyridine, and **1** = *N*-(4-pyridinyl)isonicotinamide, stacks to give dimers by intertriangle $\text{NH}\cdots\text{OC}$ hydrogen bonding. The binuclear ring complexes $[\{\text{Pd}(\text{LL})(\mu-2)\}_2](\text{CF}_3\text{SO}_3)_4$, $\text{LL} = \text{dppm} = \text{Ph}_2\text{PCH}_2\text{-PPh}_2$ or $\text{dppp} = \text{Ph}_2\text{P}(\text{CH}_2)_3\text{PPh}_2$ and **2** = $\text{NC}_5\text{H}_4\text{-3-CH}_2\text{NHCOCONHCH}_2\text{-3-C}_5\text{H}_4\text{N}$, form transannular hydrogen bonds between the bridging ligands. The complexes $[\{\text{Pd}(\text{LL})(\mu-3)\}_2](\text{CF}_3\text{SO}_3)_4$, $\text{LL} = \text{dppm}$ or dppp , $\text{L} = \text{PPh}_3$, and **3** = *N,N'*-bis(pyridin-3-yl)-pyridine-2,6-dicarboxamide, and $[\{\text{Pd}(\text{LL})(\mu-4)\}_2](\text{CF}_3\text{SO}_3)_4$, $\text{LL} = \text{dppm}$, dppp , or bu_2bipy , $\text{L} = \text{PPh}_3$, and **4** = *N,N'*-bis(pyridin-4-yl)-pyridine-2,6-dicarboxamide, are suggested to exist as U-shaped or square dimers, respectively. The ligands *N,N'*-bis(pyridin-3-yl)isophthalamide, **5**, or *N,N'*-bis(pyridin-4-yl)isophthalamide, **6**, give the complexes $[\{\text{Pd}(\text{LL})(\mu-5)\}_2](\text{CF}_3\text{SO}_3)_4$ or $[\{\text{Pd}(\text{LL})(\mu-6)\}_2](\text{CF}_3\text{SO}_3)_4$, but when $\text{LL} = \text{dppm}$ or dppp , the zigzag polymers $[\{\text{Pd}(\text{LL})(\mu-6)\}_x](\text{CF}_3\text{SO}_3)_{2x}$ are formed. When $\text{LL} = \text{dppp}$, a structure determination shows formation of a laminated sheet structure by hydrogen bonding between amide NH groups and triflate anions of the type $\text{NH}\cdots\text{OSO}\cdots\text{HN}$.

Introduction

There has been great interest in supramolecular transition metal chemistry since self-assembly through coordinate bond formation has proven to be powerful tool for constructing rings, polymers, and networks. Some of these compounds have potential uses in the context of molecular recognition, catalysis, size-selective guest transportation, optical materials, molecular magnetism, semiconductors, and conductors.^{1–4} Variation of ligand structure and coordination geometry gives rise to the variety of supramolecular structures, and it is now

possible to predict the product structures in many cases. For example, the combination of bis- or poly(pyridine) ligands with square planar palladium(II) and platinum(II) centers has yielded an impressive range of polygons, cages, and catenanes.² If the metal is constrained to have cis stereochemistry and a linear bipyridine ligand is used, a molecular square is formed, but angular or flexible bipyridine derivatives can give dimers, trimers, or polymers.²

Organic amides have proved to be useful in self-assembly through hydrogen bonding, and the products have relevance to biological systems. For example, oligoamides have been designed that can fold to give single or double helices as well as other supramolecular assemblies.⁵ In addition, amide-linked catenanes, rotaxanes, and knots have been prepared by template synthesis.⁶ Cyclic peptides can self-assemble to give interesting supramolecular structures, most notably to give nanotubes via amide–amide hydrogen bonding.⁷ This

* To whom correspondence should be addressed. E-mail: pudd@uwo.ca.

- (1) (a) Lehn, J.-M. *Supramolecular Chemistry: Concepts and Perspectives*; VCH: New York, 1995. (b) Steed, J. W.; Atwood, J. L. *Supramolecular Chemistry*; VCH: New York, 2000.
- (2) Recent reviews: (a) Fujita, M.; Umemoto, K.; Yoshizawa, M.; Fujita, N.; Kusakawa T.; Biradha K. *Chem. Commun.* **2001**, 509. (b) Holliday, B. J.; Mirkin, C. A. *Angew. Chem., Int. Ed.* **2001**, *40*, 2022. (c) Leininger, S.; Olenyuk, B.; Stang, P. J. *Chem. Rev.* **2000**, *100*, 853.
- (3) Cotton, F. A.; Lin, C.; Murillo, C. A. *Acc. Chem. Res.* **2001**, *34*, 759.
- (4) (a) Archer, R. D. *Inorganic and Organometallic Polymers*; VCH: New York, 2001. (b) Moulton, B.; Zaworotko, M. J. *Chem. Rev.* **2001**, *101*, 1629. (c) Chen, C.-T.; Suslick, K. S. *Coord. Chem. Rev.* **1993**, *128*, 293.

- (5) (a) Berl, V.; Huc, I.; Khoury R. G.; Krische, M. J.; Lehn, J.-M. *Nature* **2000**, *407*, 720. (b) Berl, V.; Huc, I.; Khoury R. G.; Lehn, J.-M. *Chem.–Eur. J.* **2001**, *7*, 2798. (c) Berl, V.; Krische, M. J.; Huc, I.; Lehn, J.-M.; Schmutz, M. *Chem.–Eur. J.* **2000**, *6*, 1938.

Chart 1

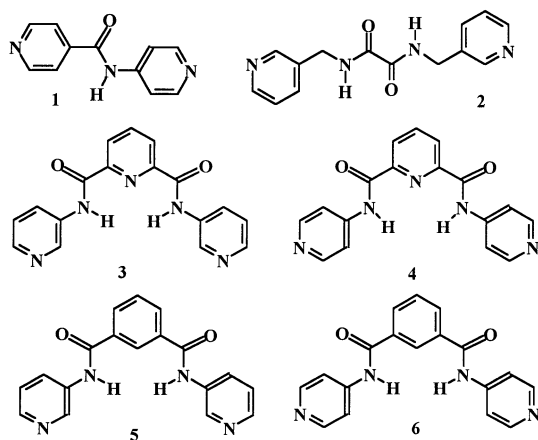

work is concerned with the use of ligands containing both amide groups that can participate in hydrogen bonding and pyridine units that can act as donors to palladium(II) or platinum(II). The ligands are shown in Chart 1, and a brief account of relevant research is given below.^{8–15}

Square or rectangular macrocycles have been prepared with osmium(VI) centers bridged by ligands similar to **6** (Chart 1), and they are able to bind diamide guests selectively and to form pseudorotaxanes.⁸ A cage complex in which two copper(II) centers were linked only by four *N,N'*-bis(4-aminomethylene)benzene-1,3-dicarboxamide ligands was shown to encapsulate an icelike decameric water cluster.⁹ The ligand **1** (Chart 1) has been used to synthesize coordination networks with methane gas adsorption properties,¹⁰ while the ligand **2** with silver(I) gave interesting two-dimensional coordination polymers in which the polymer sheets were connected by hydrogen bonding through the amide functional groups.¹¹ A rhenium(I) complex with the ligand **4** (Chart

1), as well as related complexes of ruthenium(II) and osmium(II), show anion selective recognition.¹² Helical structures have been prepared using amidopyridinyl ligands.¹³ In some cases, ligands containing the pyridine-2-carboxamide functionality can be deprotonated and the amide nitrogen atoms can also act as donors in forming complex coordination compounds.¹⁴

This paper reports the self-assembly of binuclear, trinuclear, or polynuclear complexes from cis-blocked palladium(II) or platinum(II) centers with the amidopyridine ligands **1–6** (Chart 1). The major purpose was to investigate the effect of ligand structure on the nature of the resulting self-assembly. The ligands are designed to have different degrees of flexibility and orientation of the pyridyl donor groups while retaining the amido groups that can take part in hydrogen bonding. Preliminary accounts of parts of this work have been published.¹⁵

Results

Complexes with the Ligand N-(4-Pyridinyl)isonicotinamide, 1. The reaction of the ligand **1**¹⁶ with [Pd(bu₂bipy)-(thf)₂][BF₄]₂ or [Pt(bu₂bipy)(O₃SCF₃)₂], bu₂bipy = 4,4'-di-*tert*-butyl-2,2'-bipyridine, occurred to give the complexes [M₃(bu₂bipy)₃(μ-**1**)₃]X₆ (**7a**, M = Pd, X = BF₄; **7b**, M = Pt, X = CF₃SO₃), which were isolated as colorless solids (Chart 2 for a representative structure). These complexes had similar NMR spectra, suggesting similar structures, but the spectra did not define the nuclearity of the complexes. The trimeric structure of **7b** in the solid state was established by an X-ray structure determination. In contrast, the reaction of [Pd(dppp)(O₃SCF₃)₂] with ligand **1** gave a colorless, sparingly soluble complex [Pd(dppp)(μ-**1**)_x(O₃SCF₃)_{2x}], **8**, whose ¹H NMR spectra contained broad peaks and whose ³¹P NMR spectrum contained overlapping broad peaks in the region δ(P) = 8.8–9.5. The low solubility and broad, complex NMR spectra suggest a polymeric structure.

The structure of **7b** is shown in Figure 1 and selected bond distances and angles are in Table 1. The cation [Pt₃(bu₂bipy)₃(μ-**1**)₃]⁶⁺ forms a triangular triplatinum unit with each pair of platinum atoms bridged by a bowed ligand **1**. There are two potential isomers with an unsymmetrical ligand such as **1**, containing NHC₅H₄N (a) and C(O)C₅H₄N (b) donors. The maximum symmetry of the isomers is C_{3h}, when each platinum has Pt(a)(b) coordination, and C_s, when the three platinum atoms have Pt(a)(a), Pt(b)(b), and Pt(a)(b) coordination (Chart 2). Complex **7b** has the less symmetrical symmetry (roughly C_s, assuming free rotation of ligands **1**) with Pt(3), Pt(1), and Pt(2) having the Pt(a)(a), Pt(b)(b), and Pt(a)(b) coordination respectively (Figure 1). The three Pt atoms form an approximately equilateral triangle with Pt··Pt distances of 13.1 Å, and the three PtN₄ coordination planes are roughly coplanar. However, each pyridyl group of the three bis(pyridinyl) ligands is oriented out of the molecular plane so that a large interior cavity is formed. One of the triflate anions is encapsulated in the center of this cavity (Figure 1). There are relatively short contacts N(127)O(608)

- (6) Selected references: (a) Jager, R.; Vogtle, F. *Angew. Chem., Int. Ed.* **1997**, *36*, 931. (b) Gatti, F. G.; Leigh, D. A.; Nepogodiev, S. A.; Slawin, A. M. Z.; Teat, S. J.; Wong, J. K. Y. *J. Am. Chem. Soc.* **2001**, *123*, 5983. (c) Safarowsky, O.; Nieger, M.; Frohlich, R.; Vogtle, F. *Angew. Chem., Int. Ed.* **2000**, *39*, 1616.
- (7) (a) Hartgerink, J. D.; Clark, T. D.; Ghadiri, M. R. *Chem.—Eur. J.* **1998**, *4*, 1367. (b) Ghadiri, M. R.; Kobayashi, K.; Granja, J. R.; Chadha, R. K.; McRee, D. E. *Angew. Chem., Int. Ed. Engl.* **1995**, *34*, 93.
- (8) (a) Jeong, K.-S.; Cho, Y. L.; Chang, S.-U.; Park, T.-Y.; Song, J. U. *J. Org. Chem.* **1999**, *64*, 9459. (b) Jeong, K.-S.; Cho, Y. L.; Song, J. U.; Chang, H.-Y.; Choi, M.-G. *J. Am. Chem. Soc.* **1998**, *120*, 10982. (c) Jeong, K.-S.; Choi, Y. L.; Chang, S.-U.; Chang, H.-Y. *Angew. Chem., Int. Ed.* **2000**, *39*, 1692.
- (9) Barbour, L. J.; Orr, G. W.; Atwood, J. L. *Nature* **1998**, *393*, 671.
- (10) (a) Kondo, M.; Okubo, T.; Asami, A.; Noro, S.-I.; Yoshitomi, T.; Kitagawa, S.; Ishii, T.; Mazusaka, H.; Seki, K. *Angew. Chem., Int. Ed.* **1999**, *38*, 140. (b) Kondo, M.; Asami, A.; Chang, H.-C.; Kitagawa, S. *Cryst. Eng.* **1999**, *2*, 115.
- (11) Schauer, C. L.; Matwey, E.; Fowler, F. W.; Lauher, J. W. *J. Am. Chem. Soc.* **1997**, *119*, 10245.
- (12) (a) Sun, S.-S.; Lees, A. J. *Chem. Commun.* **2000**, 1687. (b) Beer, P. D.; Szemes, F.; Balzani, V.; Sala, C. M.; Drew, M. G. B.; Dent, S. W.; Maestri, M. *J. Am. Chem. Soc.* **1997**, *119*, 11864.
- (13) Qin, Z.; Jennings, M. C.; Puddephatt, R. J. *Chem.—Eur. J.* **2002**, *8*, 735.
- (14) (a) Fatin-Rouge, N.; Blanc, S.; Leize, E.; Van Dorsselaer, A.; Baret, P.; Pierre, P.-L.; Albrecht-Gary, A.-M. *Inorg. Chem.* **2000**, *39*, 5771. (b) Rowland, J. M.; Thornton, M. L.; Olmstead, M. M.; Mascharak, P. K. *Inorg. Chem.* **2001**, *40*, 1069.
- (15) Qin, Z.; Jennings, M. C.; Puddephatt, R. J. *Chem. Commun.* **2001**, 2676. Qin, Z.; Jennings, M. C.; Puddephatt, R. J. *Chem. Commun.* **2002**, 354.

- (16) Gardner, T. S.; Wenis, E.; Lee, J. *J. Org. Chem.* **1954**, *19*, 753.

Table 1. Selected Bond Distances (Å) and Angles (deg) for Complex **7b**

Pt(1)–N(101)	2.02(2)	Pt(2)–N(121)	1.98(2)	Pt(3)–N(141))	2.01(2)
Pt(1)–N(153)	2.03(1)	Pt(2)–N(113)	2.04(2)	Pt(3)–N(133)	2.03(2)
Pt(1)–N(1)	1.99(2)	Pt(2)–N(21)	1.99(1)	Pt(3)–N(41)	1.98(2)
Pt(1)–N(12)	2.02(1)	Pt(2)–N(32)	2.00(2)	Pt(3)–N(52)	1.99(2)
N(101)–Pt(1)–N(153)	86.0(6)	N(121)–Pt(2)–N(113)	83.5(8)	N(141)–Pt(3)–N(133)	85.9(7)
N(1)–Pt(1)–N(12)	79.9(6)	N(21)–Pt(2)–N(32)	80.8(7)	N(41)–Pt(3)–N(52)	81.3(9)
N(12)–Pt(1)–N(101)	97.5(6)	N(121)–Pt(2)–N(32)	98.8(8)	N(52)–Pt(3)–N(141)	96.2(8)
N(1)–Pt(1)–N(153)	96.6(6)	N(21)–Pt(2)–N(113)	97.0(7)	N(41)–Pt(3)–N(133)	96.5(8)
N(1)–Pt(1)–N(101)	176.0(6)	N(121)–Pt(2)–N(21)	176.9(8)	N(41)–Pt(3)–N(141)	176.9(8)
N(12)–Pt(1)–N(153)	176.4(6)	N(32)–Pt(2)–N(113)	177.0(8)	N(52)–Pt(3)–N(133)	177.8(7)

Hydrogen Bonding			
DH··A	D··A (Å)	H··A (Å)	DH··A (°)
N(107)–H(10F)··O(148A)	2.95(4)	2.15	151
N(127)–H(12E)··O(801)(water)	2.95(5)	2.13	155
N(149)–H(14H)··O(206)(OTf)	2.75(3)	1.90	163

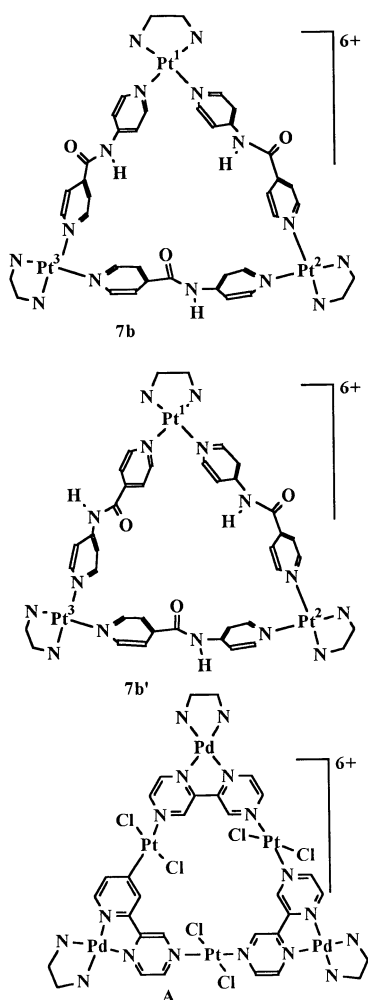
Chart 2^a

^a NN = 4,4'-Di-*tert*-butyl-2,2'-bipyridine.

= 3.13 and N(149)O(606) = 3.19 Å, but the orientation is not appropriate for hydrogen bonding and it is likely that this just represents a close fit of the triflate ion in the cavity.

An interesting supramolecular association occurs between pairs of triangular cations as illustrated in Figure 1b. The adjacent triangles are parallel to each other with a separation of about 5.1 Å. The association occurs primarily through NH··O=C hydrogen bonding between amide groups. There are pairwise interactions with N(107)··O(148A) = N(107A)··O(148) = 2.95(5) Å. These attractions are sup-

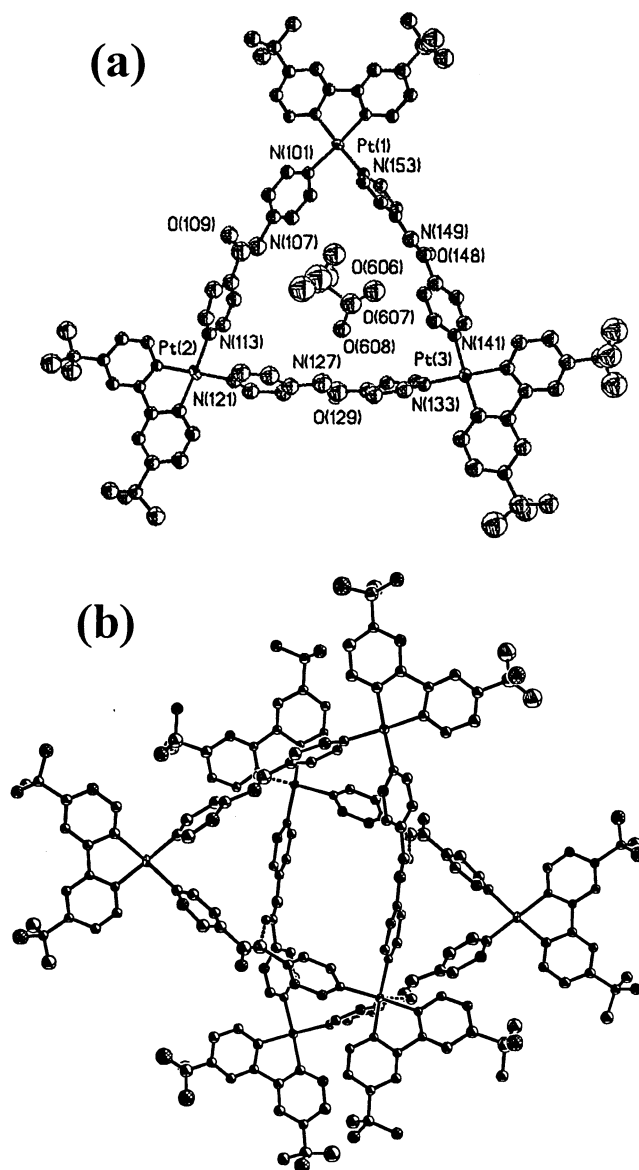
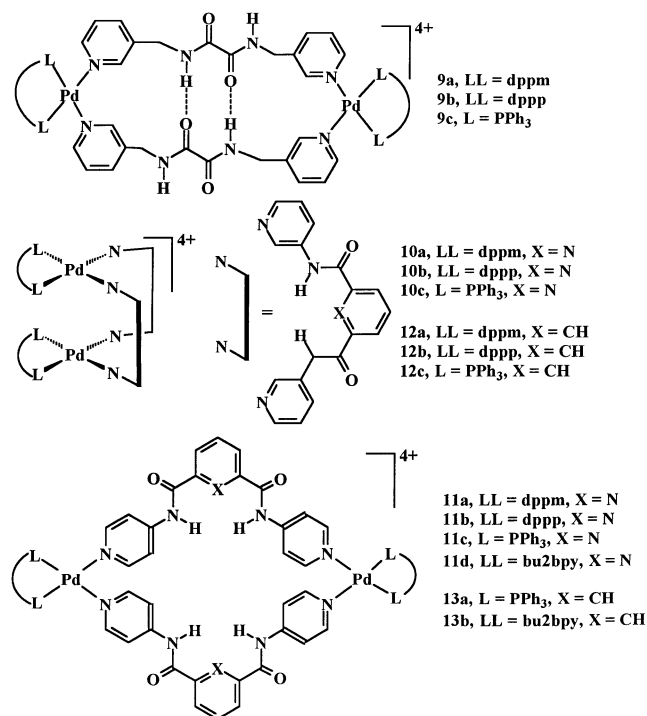

Figure 1. (a) View of the structure of the triangular cationic complex **7b**, with a triflate anion included in the cavity. (b) Stacking of pairs of triangles through NH··O=C hydrogen bonding and weak C=O··Pt bonds.

ported by two long C=O··Pt contacts with O(129)··Pt(1A) = O(129A)··Pt(1) = 3.36 Å that probably represent electrostatic attractions. The NH groups that are not involved in this hydrogen bonding between triangles take part in

Chart 3



hydrogen bonding either with a triflate anion [N(149)··O(206) = 2.75(3) Å] or with a water molecule [N(127)··O(801) = 2.95(5) Å]. The carbonyl groups C(128)O(129) and C(108)O(109) are not involved in hydrogen bonding. These “dimer of trimer” cations contain two triflate ions in their cavities (Figure 1a) and are surrounded by further disordered triflate ions, as well as by water and acetone solvate molecules, but there is no bridging between adjacent “dimers of trimers”. The packing motif is thus different from that of a related triangular hexacation (A, Chart 2) in which all triangles are separated by the same distance and connected by a channel of counterions and water molecules.¹⁷ It is possible that the unsymmetrical ring structure found in the structure of **7b** is favored over the more symmetrical one (**7b'**, Chart 2) as a result of the favorable supramolecular association since there is no obvious reason it would be favored for a simple ring structure. The complex cation **7b** appears to be the first example of a cyclic coordination compound that forms a dimer architecture similar to that formed by cyclic peptides.^{7b}

Reactions with the Dipyridyl Ligand 2. The ligand **2**,¹¹ which differs from **1** in being more symmetrical and flexible, reacted with [Pd(dppm)(O₃SCF₃)₂], [Pd(dppp)(O₃SCF₃)₂], or [Pd(PPh₃)₂(O₃SCF₃)₂] to give the corresponding dimeric ring complexes [{PdL₂(*μ*-**2**)₂](CF₃SO₃)₄ (**9a**, L₂ = dppm = Ph₂-PCH₂PPh₂; **9b**, L₂ = dppp; **9c**, L = PPh₃) as colorless, air-stable complexes (Chart 3). The ¹H NMR spectra showed the expected ligand resonances, and the ³¹P NMR spectra each displayed a singlet resonance, indicating the formation of a single symmetric compound in each case. The binuclear structure was established crystallographically for **9a,b**. At-

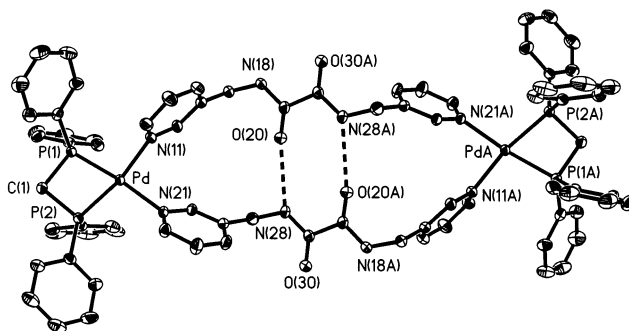

Figure 2. View of structure of complex **9a** showing the transannular NH··O=C hydrogen bonding.

Table 2. Selected Bond Distances (Å) and Angles (deg) for the Complex **9a**

Pd–N(11)	2.100(2)	Pd–P(1)	2.2448(9)
Pd–N(21)	2.113(3)	Pd–P(2)	2.2571(8)
N(11)–Pd–N(21)	87.35(10)	N(11)–Pd–P(2)	168.79(8)
N(11)–Pd–P(1)	98.68(8)	N(21)–Pd–P(2)	102.83(7)
N(21)–Pd–P(1)	173.89(7)	P(1)–Pd–P(2)	71.08(3)
Hydrogen Bonding			
DH··A	D··A (Å)	H··A (Å)	DH··A (°)
N(28)–H(28A)··O(20)	2.916(4)	2.10	153
N(18)–H(18A)··O(48B)(OTf)	3.00(2)	2.29	138
N(18)–H(28A)··O(58B)(OTf)	2.88(2)	2.17	137

tempts to prepare the corresponding bu₂bipy complex were unsuccessful since an intractable mixture of compounds was obtained.

A view of the molecular structure of **9a** is shown in Figure 2a, while selected bond distances and angles are given in Table 2. The structure establishes the formation of a 26-membered macrocycle containing two identical palladium atoms that are related by crystallographic inversion center and are separated by 14.9 Å. The ring adopts an extended chair conformation, and it is anchored in place by formation of transannular hydrogen bonds between the inward directed C=O and N–H groups (Figure 2a, O(20)··N(28) = O(20A)··N(28A) = 2.916(4) Å). The outward directed C=O and N–H groups do not engage in analogous intermolecular hydrogen bonding, but these NH groups instead hydrogen bond to triflate anions. The other triflate anion forms a secondary bond to palladium with Pd··O = 2.80 Å. To test if hydrogen-bonding solvents might compete with the transannular hydrogen bonding and perhaps give different products, the similar synthesis was carried out using CH₂-Cl₂/MeOH or DMF as solvent. In both cases, the same product **9a** was formed exclusively, as identified by its NMR spectra. The transannular hydrogen bonding in **9a** is thus strong enough to compete with solvent hydrogen bonding in these cases.

A partial structure determination was carried out for the similar complex **9b**, but the crystal diffracted only weakly and a full refinement was not possible. The connectivity of the cation is established, and the structure of the complex is similar to that of the complex **9a**. Thus, there is a 26-membered ring in a chair conformation, containing two palladium atoms. The transannular hydrogen bonding is also similar to that in **9a**, but there is no hydrogen bonding between triflate and the outward directed NH groups.

(17) Schnebeck, R.-D.; Freisinger, E.; Lippert, B. *Chem. Commun.* **1999**, 675.

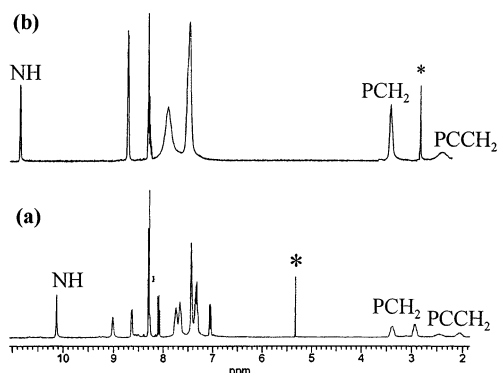

Figure 3. ^1H NMR spectra of (a) complex **10b** and (b) complex **11b**. Note the doubling of the PCH_2 and central CH_2 resonances for **10b** that results from the U-shaped structure. The peaks labeled with asterisks are due to solvent dichloromethane in (a) and acetone in (b); see Experimental Section for assignment of aryl resonances.

Complexes with the Bis(pyridyl) Ligands 3 and 4. These ligands were easily prepared by reaction of 2,6-pyridinedicarbonyl dichloride with 2 equiv of 3- or 4-aminopyridine in the presence of triethylamine. These compounds have very limited solubility in common organic solvents, probably owing to intermolecular hydrogen bonding, but they are soluble in DMF or DMSO.

The reactions of **3** or **4** with $[\text{Pd}(\text{LL})(\text{O}_3\text{SCF}_3)_2]$ gave the corresponding complexes $[\{\text{Pd}(\text{LL})(\mu\text{-}3)\}_x](\text{CF}_3\text{SO}_3)_{2x}$ (**10a**, LL = dppm; **10b**, LL = dppp; **10c**, L = PPh_3) or $[\{\text{Pd}(\text{LL})(\mu\text{-}4)\}_x](\text{CF}_3\text{SO}_3)_{2x}$ (**11a**, LL = dppm; **11b**, LL = dppp; **11c**, L = PPh_3 ; **11d**, LL = bu_2bipy). The complexes **10** are suggested to exist as U-shaped dimers with $x = 2$, on the basis of the NMR spectra, but it has not been possible to confirm this by X-ray structure determination. The spectra of **10b** are discussed as an example. The ^{31}P NMR spectrum contained only a singlet, indicating the presence of a single isomer with equivalent phosphine ligands. The ^1H NMR spectrum also indicated that the dipyriddy ligands were symmetrically bonded (for example, a single sharp NH resonance was observed). However, two sets of resonances were observed for each of the CH_2 resonances of the diphosphine ligand (Figure 3), indicating nonequivalence of each CH^aH^b group. The NMR data are thus fully consistent with the structure shown in Chart 3, having effective C_{2v} symmetry, and this is consistent with the natural orientation of the bis(3-pyridyl) ligands.

On the basis of their NMR spectra, the complexes **11** have effectively planar structures (Chart 3). Thus, the ^{31}P NMR spectrum of **11b** contained a single resonance and there was only a single resonance in the ^1H NMR spectrum for each of the α - and β - CH_2 groups, in contrast to the spectrum of the U-shaped **10b** described above (Figure 3). This effective geometry is not surprising given the right angle geometry of the ligand, but fluxionality is needed to overcome the expected bowing of the ligand.¹⁸

The structure of complex **11a** is shown in Figure 4, and selected bond distances and angles are in Table 3. There is a roughly square 32-membered ring, $\text{Pd}_2(\mu\text{-}4)_2^{4+}$, containing

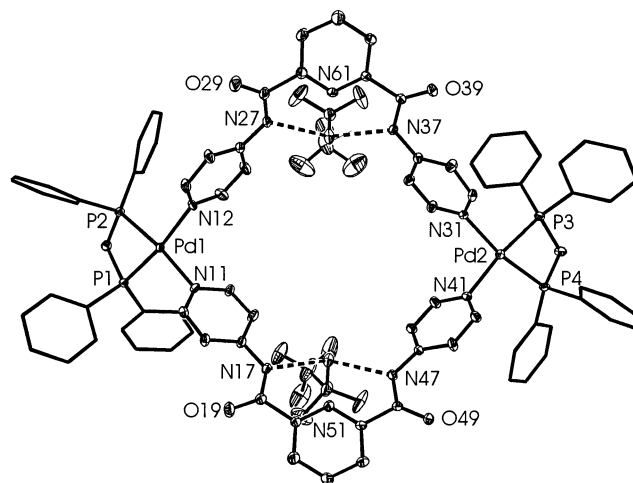

Figure 4. Top view of the "square" structure of the cationic complex **11a**, with hydrogen bonding to two triflate anions.

Table 3. Selected Bond Distances (Å) and Angles (deg) for the Complex **11a**

Pd(1)–N(21)	2.109(5)	Pd(2)–N(41)	2.094(6)
Pd(1)–N(11)	2.114(5)	Pd(2)–N(31)	2.108(6)
Pd(1)–P(2)	2.253(2)	Pd(2)–P(4)	2.253(2)
Pd(1)–P(1)	2.260(2)	Pd(2)–P(3)	2.254(2)
N(21)–Pd(1)–N(11)	92.7(2)	N(41)–Pd(2)–N(31)	91.0(2)
N(21)–Pd(1)–P(2)	96.0(2)	N(41)–Pd(2)–P(4)	9.1(2)
N(11)–Pd(1)–P(2)	171.3(2)	N(31)–Pd(2)–P(4)	169.8(2)
N(21)–Pd(1)–P(1)	167.5(2)	N(41)–Pd(2)–P(3)	171.1(2)
N(11)–Pd(1)–P(1)	98.6(2)	N(31)–Pd(2)–P(3)	97.6(2)
P(2)–Pd(1)–P(1)	72.64(6)	P(4)–Pd(2)–P(3)	72.29(7)
Hydrogen Bonding			
DH···A	D···A (Å)	H···A (Å)	DH···A (°)
N(17)–H(17A)···O(98A)(OTf)	3.074(9)	2.26	153
N(47)–H(47A)···O(98A)(OTf)	2.989(8)	2.15	158
N(27)–H(27A)···O(108)(OTf)	3.033(9)	2.18	164
N(37)–H(37A)···O(108)(OTf)	3.002(8)	2.16	160

two palladium atoms, each of which carries a chelating dppm ligand. The ligands **4** are significantly bowed so that a single oxygen atom of a triflate anion hydrogen bonds weakly to both NH groups [$\text{N}(17)\cdots\text{O}(98) = 3.074(9)$ Å, $\text{N}(47)\cdots\text{O}(98) = 2.989(8)$ Å; $\text{N}(27)\cdots\text{O}(108) = 3.033(9)$ Å, $\text{N}(37)\cdots\text{O}(108) = 3.002(8)$ Å].

Complexes with the Bis(pyridyl) Ligands 5 and 6. The ligand **5** reacted with $[\text{Pd}(\text{LL})(\text{O}_3\text{SCF}_3)_2]$ to give the corresponding complexes $[\{\text{Pd}(\text{LL})(\mu\text{-}5)\}_2](\text{CF}_3\text{SO}_3)_4$ (**12a**, LL = dppm; **12b**, LL = dppp; **12c**, L = PPh_3). On the basis of their spectroscopic properties, which are very similar to those of the corresponding complexes **10a–c**, the compounds are thought to have similar U-shaped geometries (Chart 3).

The ligand **6** gave more complex behavior. It reacted with $[\text{Pd}(\text{LL})(\text{O}_3\text{SCF}_3)_2]$ to give the complexes $[\{\text{Pd}(\text{LL})(\mu\text{-}6)\}_2](\text{CF}_3\text{SO}_3)_4$ (**13a**, L = PPh_3 ; **13b**, LL = bu_2bipy), which were soluble in common organic solvents and gave NMR spectra similar to those of **11c,d**, suggesting similar ring structures (Chart 3). In contrast, the reaction of ligand **6** with $[\text{Pd}(\text{LL})(\text{O}_3\text{SCF}_3)_2]$ gave polymeric complexes $[\{\text{Pd}(\text{LL})(\mu\text{-}6)\}_x](\text{CF}_3\text{SO}_3)_{2x}$ (**14a**, LL = dppm; **14b**, LL = dppp) and not square complexes analogous to complexes **11**. Complexes **14a,b** were sparingly soluble in methanol and acetone, respectively, but both were soluble in DMF or DMSO. Their ^1H NMR

(18) Hunter, C. A.; Sarson, L. D. *Angew. Chem., Int. Ed. Engl.* **1994**, *33*, 2313.

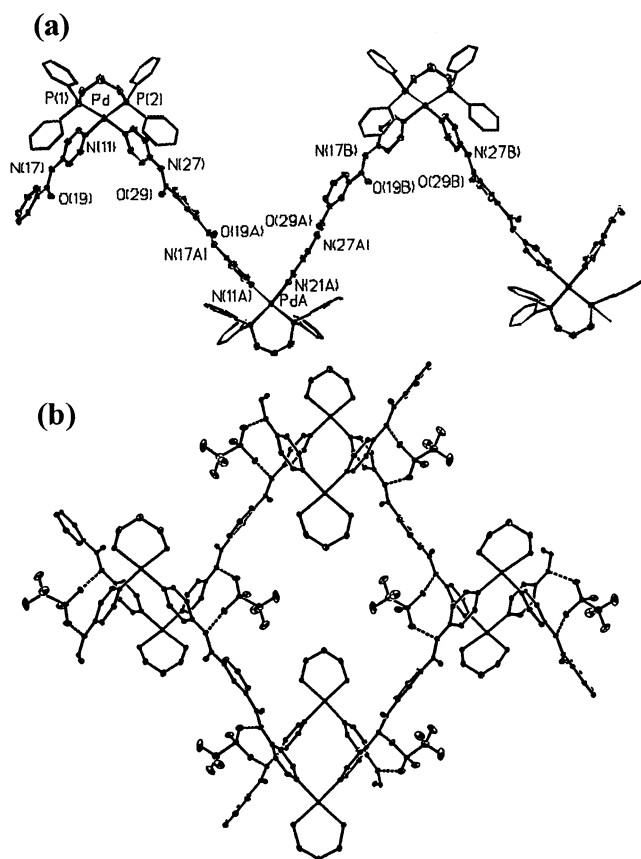

Figure 5. Structure of complex **14b**: (a) part of an infinite zigzag chain; (b) part of the laminated sheet structure formed by triflate anions bridging between zigzag polymeric chains of **14b**.

Table 4. Selected Bond Distances (Å) and Angles (deg) for the Complex **14b**

Pd–N(21)	2.105(4)	Pd–P(2)	2.267(1)
Pd–N(11)	2.095(4)	Pd–P(1)	2.271(1)
N(21)–Pd–N(11)	85.7(1)	P(2)–Pd–P(1)	93.29(5)
N(21)–Pd–P(2)	91.0(1)	N(11)–Pd–P(1)	89.9(1)
N(11)–Pd–P(2)	176.1(1)	N(21)–Pd–P(1)	175.1(1)
Hydrogen Bonding			
DH··A	D··A (Å)	H··A (Å)	DH··A (°)
N(27)–H(27A)··O(57)	2.904(6)	2.04	169
N(17)–H(17A)··O(56C)	2.947(5)	2.09	163

spectra were surprisingly simple and well resolved, and the ^{31}P NMR spectra contained only a single resonance, possibly indicating a simpler structure in solution, but the polymeric structure of **14b** was established in the solid state by an X-ray structure determination.

The structure of **14b** is shown in Figure 5, while the bond distances and angles are listed in Table 4. Parts of a several polymer chains are shown in Figure 5. The cation exists in the form of a one-dimensional zigzag coordination polymer in which all carbonyl groups are oriented on one side and all NH groups on the other. There is short-range helicity induced by the bridging ligands **6**. These bridging ligand **6** adopts an unusual conformation in which the amide groups are displaced to opposite sides of the central C_6H_4 group to give a stretched conformation compared to the more bowed conformation of the similar ligand **4** in complex **11a** (Figure 4), in which the amide groups are displaced to the same side

of the central $\text{C}_6\text{H}_3\text{N}$ group. The separation between neighboring palladium atoms is therefore longer in **14b** at 19.1 Å than in **11a** at 12.6 Å. All palladium atoms are crystallographically equivalent, but neighboring centers have opposite chirality so that the polymer has the syndiotactic structure.¹⁹

The packing motif is such that adjacent polymer chains are arranged with all NH groups directed inward and CO groups directed outward (Figure 5). In this arrangement, direct $\text{C}=\text{O}\cdots\text{HN}$ hydrogen bonding between adjacent chains is not possible. Instead, one triflate anion bridges between two NH groups from neighboring chains with $\text{O}(57)\cdots\text{N}(27) = 2.904(6)$ and $\text{O}(56)\cdots\text{N}(17\text{A}) = 2.947(5)$ Å. The second triflate anion is not involved in hydrogen bonding. By symmetry, two chains cross each bridging ligand **6**, with N(17) bridging to one chain and N(27) to the other. The overall result is a sheet structure with the triflate ions sandwiched in the center. The outside face of the sheet is lined with the carbonyl groups directed outward and an array of phenyl groups. The intersheet interactions appear to be relatively weak, though there could be weak $\text{C}=\text{O}\cdots\text{HC}$ hydrogen bonding and π -stacking between phenyl groups. The solvate acetone and methanol molecules are located in the intersheet region.

Discussion

The reaction of cis-blocked palladium(II) and platinum(II) precursors with strictly linear bipyridyl ligands is known to give molecular squares by 4 + 4 self-assembly, but angular or flexible bis(pyridyl) ligands can yield cyclic dimers or trimers by 2 + 2 or 3 + 3 self-assembly.^{2,20,21} In one case, involving the more labile palladium(II), an equilibrium between molecular triangles and squares was established.²⁰ In the present work, using amidobis(pyridyl) ligands, dimers, trimers, and polymers (but no cyclic tetramers) have been characterized, and further supramolecular association is often observed through hydrogen bonding of the amide groups.

The ligand **1**, which adopts the trans conformation,¹⁰ gives a distorted linear coordination geometry because of twisting of the amide group, and the self-assembly using the $[\text{M}(\text{bu}_2\text{-bipy})]^{2+}$ template leads to formation of molecular triangles. Complications arise because of the lack of symmetry of the ligand, and in the crystallographically characterized derivative **7b** (Figure 1), all platinum centers have different coordination. This unsymmetrical arrangement within each triangle is favorable for intertriangle association through $\text{C}=\text{O}\cdots\text{HN}$ hydrogen bonding between amide groups. The physical and NMR properties of the complex derived from **1** and the template $[\text{Pd}(\text{dppp})]^{2+}$ suggest a polymeric rather than triangular structure, but in the absence of X-ray data, this conclusion is tentative. The ligand **2** is much more flexible than **1** and could accommodate any of the known

(19) (a) Shii, Y.; Motoda, Y.; Matsuo, T.; Kai, F.; Nakashima, T.; Tuchagues, J.-P.; Matsumoto, N. *Inorg. Chem.* **1999**, *38*, 3513. (b) Ellis, W. W.; Schmitz, M.; Arif, A. A.; Stang, P. J. *Inorg. Chem.* **2000**, *39*, 2547.

(20) Fujita, M.; Sasaki, O.; Mitsuhashi, T.; Fujita, T.; Yazaki, J.; Yamaguchi, K.; Ogura, K. *Chem. Commun.* **1996**, 1535.

(21) Tabellion, F. M.; Seidel, S. R.; Arif, A. M.; Stang, P. J. *J. Am. Chem. Soc.* **2001**, *123*, 7740.

structures, but it gives the dimers **9** (Figure 2) selectively because the intramolecular hydrogen bonding is very favorable.¹¹

Due to the intramolecular N–H···N and C–H···O hydrogen bonding, as well as repulsive H–H interactions, the ligands **3** and **4** tend to adopt conformations similar to those shown in Chart 1. The approximately parallel coordination geometry (bite angle ca. 0°) favored by **3** is expected and is found to lead to U-shaped dimers by self-assembly. Ligand **4**, with approximately right-angled coordination geometry, also forms cyclic dimers **11** by self-assembly, but they are much closer to planar compared to **10**. The only hydrogen bonding in **11a** occurs between the amide groups and the anions (Figure 4). The ligands **5** and **6** are clearly related to **3** and **4**, and the self-assembly reactions are similar in many cases. However, the most remarkable result is the formation of polymers from **6** in some cases, most notably in complex **14b** (Figure 5). The solution spectra are consistent in all cases with cyclic dimer formation, and it is possible that the polymers are formed only during the crystallization process. In any case, the structure of **14b** is remarkable both in forming syndiotactic polymer chains and in the secondary association through hydrogen bonding that leads to a sheet structure, in which triflate anions are sandwiched between layers of polymeric cations **14b**. The hydrogen bonding is of the type NH···OSO···HN, with a single triflate anion bridging between NH groups. The β -sheet is very important in protein structures, but this involves the more conventional association –C=O···HN between amide groups of neighboring chains.²² There is clearly a potential to form coordination analogues of the β -sheet in complexes of the general type reported here.

Overall, this work shows how the incorporation of amide groups into dipyrindyl ligands gives a new dimension to the self-assembly of complex structures and, at least in some cases, the overall nature of the hydrogen bonded superstructure can be predicted. However, similar energies of ring and polymeric structural forms are possible and are difficult to predict at this point. There is clear scope for further advances using such ligands.

Experimental Section

NMR spectra were recorded by using Varian Mercury 400 or Inova 400 MHz spectrometers. ¹H and ¹³C NMR chemical shifts are reported relative to TMS, and ¹⁹F and ³¹P chemical shifts are reported relative to external CFCl₃ or 85% H₃PO₄, respectively. IR spectra were recorded as Nujol mulls using a Perkin-Elmer 2000 FTIR spectrometer.

***N,N'*-Bis(pyridin-3-yl)pyridine-2,6-dicarboxamide, 3.** To a solution of pyridine-2,6-dicarbonyl dichloride (2.040 g, 10.00 mmol) in dry CH₂Cl₂ (30 mL) at 0 °C was added a solution of 3-aminopyridine (1.882 g, 20.00 mmol) and triethylamine (4.2 mL, 30 mmol) in CH₂Cl₂ (20 mL). The mixture was stirred at ambient temperature for 2 h and subsequently heated at reflux for 3 h. After the mixture was cooled to room temperature, the solid was collected by filtration, washed with saturated aqueous NaHCO₃ solution,

water, acetone, and ether, and dried under vacuo, giving the ligand as a white solid. Yield: 98%. IR (Nujol): 3171, 3057, 1681 cm⁻¹. NMR in DMSO: δ (¹H) = 11.15 [s, 2H, CONH], 9.09 [d, ⁴J(HH) = 3 Hz, 2H, H² py], 8.41 [m, 4H, H⁶ py + H^{3,5} pya], 8.32 [m, 3H, H⁴ py + H⁴ pya], 7.49 [dd, *J*(HH) = 8, 5 Hz, 2H, H⁵ py]; δ (¹³C) 162.7, 149.0, 146.0, 143.4, 141.0, 135.3, 128.9, 126.3, 124.4. MS: *m/z* = 319.107; calcd for C₁₇H₁₃N₅O₂, *m/z* = 319.1069. Mp: 228 °C.

***N,N'*-Bis(pyridin-4-yl)pyridine-2,6-dicarboxamide, 4.** This was prepared by the same procedure except that 4-aminopyridine was used instead of 3-aminopyridine. Yield: 93%. IR (Nujol): 3175, 3087, 3032, 1690, 1674 cm⁻¹. NMR in DMSO: δ (¹H) = 11.25 [s, 2H, CONH], 8.56 [d, ³J(HH) = 4 Hz, 4H, H^{2,6} py], 8.42 [d, ³J(HH) = 8 Hz, 2H, H^{3,5} pya], 8.33 [t, 1H, ³J(HH) = 8 Hz, H⁴ pya], 7.95 [d, ³J(HH) = 5 Hz, 4H, H^{3,5} py]; δ (¹³C) 163.2, 151.2, 148.9, 145.5, 129.4, 126.8, 115.1. MS: *m/z* = 319.107; calcd for C₁₇H₁₃N₅O₂, *m/z* = 319.1069. Mp: >300 °C.

***N,N'*-Bis(pyridin-3-yl)benzene-1,3-dicarboxamide, 5.** This was prepared as for **3** except that benzene-1,3-dicarbonyl dichloride was used instead of pyridine-2,6-dicarbonyl dichloride. Yield: 95%. IR (Nujol): 3233, 3175, 1676 cm⁻¹. NMR in DMSO: δ (¹H) = 10.67 [s, 2H, CONH], 8.95 [d, ⁴J(HH) = 3 Hz, 2H, H² py], 8.57 [d, ³J(HH) = 6 Hz, 1H, H² bz], 8.31 [d, ³J(HH) = 7 Hz, 2H, H⁶ py], 8.18 [m, 4H, H^{4,6} bz + H⁴ py], 7.73 [t, ³J(HH) = 7 Hz, 1H, H⁵ bz], 7.40 [dd, ³J(HH) = 8, 4 Hz, 2H, H⁵ py]; δ (¹³C) = 166.1, 145.4, 142.7, 136.4, 135.3, 131.7, 129.5, 128.1, 127.8, 124.3. MS: *m/z* = 318.111; calcd for C₁₈H₁₄N₄O₂, *m/z* = 318.1117. Mp: 255 °C.

***N,N'*-Bis(pyridin-4-yl)-benzene-1,3-dicarboxamide, 6.** This was prepared by same procedure for **5** except that 4-aminopyridine was used instead of 3-aminopyridine. Yield: 81%. IR (Nujol): 3228, 3162, 1673 cm⁻¹. NMR in DMSO: δ (¹H) = 10.78 [s, 2H, CONH], 8.53 [s, 1H, H² bz], 8.48 [d, ³J(HH) = 5 Hz, 4H, H^{2,6} py], 8.17 [d, ³J(HH) = 8 Hz, 2H, H^{4,6} bz], 7.79 [d, ³J(HH) = 5 Hz, 4H, H^{3,5} py], 7.72 [t, ³J(HH) = 8 Hz, 1H, H⁵ bz]; δ (¹³C) = 166.6, 151.1, 146.5, 135.2, 132.1, 129.6, 128.0, 114.7. MS: *m/z* = 318.111; calcd for C₁₈H₁₄N₄O₂, *m/z* = 318.1117. Mp: >350 °C.

[(*bu*₂bipy)Pd(μ -NC₅H₄-4-CONH-4-C₅H₄N)]₃(BF₄)₆, 7a. To a solution of *N*-(pyridin-4-yl)isonicotinamide (0.020 g, 0.100 mmol) in THF (10 mL) was added a filtered solution of [(*bu*₂bipy)Pd(thf)₂](BF₄)₂ generated in situ from [(*bu*₂bipy)PdCl₂] (0.045 g, 0.100 mmol) and AgBF₄ (0.039 g, 0.200 mmol) in CH₂Cl₂/THF (10/10 mL). The white precipitate which formed immediately was collected by filtration, washed with ether, and dried under vacuo. Yield: 82%. Anal. Calcd for C₂₉H₃₃B₂F₈N₅OPd·H₂O: C, 45.49; H, 4.61; N, 9.15. Found: C, 45.41; H, 4.40; N, 9.00. IR (Nujol): 1706, 1071 cm⁻¹. ¹H NMR (acetone-*d*₆): δ = 11.0 [s, 2H, CONH], 9.58 [s, 2H, H^{2,6}], 9.23 [s, 2H, H^{2,6'}], 8.78 [s, 2H, H^{3,3'} *bu*₂bipy], 7.65–8.30 [m, 8H, H^{3,5,3'5'} + H^{5,6,5'6'} *bu*₂bipy], 1.42 [s, 18, Bu]. Mp: >300 °C, dec.

[(*bu*₂bipy)Pt(μ -NC₅H₄-4-CONH-4-C₅H₄N)]₃(CF₃SO₃)₆, 7b. To a solution of *N*-(pyridin-4-yl)isonicotinamide (0.020 g, 0.100 mmol) in THF (10 mL) was added a filtered solution of [(*bu*₂bipy)-Pt(OTf)₂] generated in situ from [(*bu*₂bipy)PtCl₂] (0.053 g, 0.100 mmol) and AgOTf (0.052 g, 0.200 mmol) in CH₂Cl₂/THF (10/10 mL). The white precipitate was collected by filtration, washed with ether, and dried under vacuo. Yield: 68%. Anal. Calcd for C₉₃H₉₉F₁₈N₁₅O₂₁Pt₃S₆·3H₂O: C, 38.04; H, 3.60; N, 7.15. Found: C, 38.08; H, 3.30; N, 6.84. IR (Nujol): 1705, 1163, 1030 cm⁻¹. ¹H NMR (acetone-*d*₆): δ = 11.0 [s, CONH], 9.60 [s, 2H, H^{2,6}], 9.25 [s, 2H, H^{2,6'}], 8.82 [s, 2H, H^{3,3'} *bu*₂bipy], 7.65–8.30 [m, 8H, H^{3,5,3'5'} + H^{5,6,5'6'} *bu*₂bipy], 1.45 [s, 18H, Bu]. Mp: 242 °C. Single crystals suitable for X-ray structure determination were grown by slow diffusion of a methanol/acetone solution of the complex into water.

(22) (a) Kyte, J. *Structure in Protein Chemistry*; Garland Inc.: New York, 1995. (b) Jeffrey, G. A.; Saenger, W. *Hydrogen Bonding in Biological Systems*; Springer-Verlag: Berlin, 1994.

$[(\text{dppp})\text{Pd}(\mu\text{-NC}_5\text{H}_4\text{-4-CONH-4-C}_5\text{H}_4\text{N})_x](\text{CF}_3\text{SO}_3)_{2x}$, **8**. To a mixture of $[\text{Pd}(\text{dppp})(\text{OTf})_2]$ (0.041 g, 0.050 mmol) and *N*-(pyridin-4-yl)isonicotinamide (0.010 g, 0.050 mmol) was added THF. The white precipitate of the product was collected by filtration, washed with ether, and dried under vacuo. Yield: 98%. Anal. Calcd for $\text{C}_{40}\text{H}_{35}\text{F}_6\text{N}_5\text{O}_8\text{P}_2\text{PdS}_2\cdot\text{H}_2\text{O}$: C, 47.18; H, 3.66; N, 4.13. Found: C, 46.93; H, 3.53; N, 4.09. IR (Nujol): 3176, 3067, 1700, 1159, 1030 cm^{-1} . ^1H NMR (nitrobenzene-*d*₅): δ = 11.0 [s, CONH], 9.25 [m, 2H, H^{2,6}], 8.82 [m, 2H, H^{2,6}], 7.65–8.30 [m, overlap with solvent peaks], 2.94 [s, 4H, PCH₂], 2.25 [s, 2H, PCCH₂]. $^{31}\text{P}\{^1\text{H}\}$ NMR (nitrobenzene-*d*₅): δ 8.8–9.5 [m]. Mp: 255 °C, dec.

$[\text{Pd}(\text{dppm})(\mu\text{-NC}_5\text{H}_4\text{-3-CH}_2\text{NHCOCNHCH}_2\text{-3-C}_5\text{H}_4\text{N})_2](\text{CF}_3\text{SO}_3)_4$, **9a**. To a mixture of $[\text{Pd}(\text{dppm})(\text{CF}_3\text{SO}_3)_2]$ (0.079 g, 0.100 mmol) and *N,N'*-bis(pyridin-3-ylmethyl)oxalamide (0.027 g, 0.100 mmol) was added CH_2Cl_2 (10 mL). The white precipitate of the product was collected by filtration, washed with pentane, and dried in vacuo. Yield: 96%. Anal. Calcd for $\text{C}_{41}\text{H}_{36}\text{F}_6\text{N}_4\text{O}_8\text{P}_2\text{-PdS}_2$: C, 46.49; H, 3.43; N, 5.29. Found: C, 46.44; H, 3.28; N, 5.30. IR (Nujol): 3355, 3068, 1684, 1154, 1027 cm^{-1} . ^1H NMR (acetone): δ = 9.35 [s, 2H, H² py], 8.92 [t, 2H, *J*(NH) = 6 Hz, 2H, NH], 8.62 [s, 2H, H⁶ py], 7.95 [m, 8H, H^{2,6} Ph], 7.81 [d, 3J (HH) = 8 Hz, 2H, H⁴ py], 7.67 [m, 4H, H⁴ Ph], 7.55 [m, 8H, H^{3,5} Ph], 7.37 [dd, *J*(HH) = 8, 5 Hz, 2H, H⁵ py], 5.19 [t, 2J (PH) = 12 Hz, 2H, PCH₂], 4.62 [d, 3J (HH) = 6 Hz, 4H, NCH₂]. $^{31}\text{P}\{^1\text{H}\}$ NMR (acetone): δ = -37.53 [s]. ^{19}F NMR (acetone): δ = -79.11 [s]. Mp: 258 °C. Single crystals were obtained from a saturated acetone solution by slow evaporation.

$[\{\text{Pd}(\text{dppp})(\mu\text{-NC}_5\text{H}_4\text{-3-CH}_2\text{NHCOCNHCH}_2\text{-3-C}_5\text{H}_4\text{N})_2](\text{CF}_3\text{SO}_3)_4$, **9b**. This was prepared in a similar way as for **9a** except that $[\text{Pd}(\text{dppp})(\text{CF}_3\text{SO}_3)_2]$ was used. Yield: 99%. Anal. Calcd for $\text{C}_{43}\text{H}_{40}\text{F}_6\text{N}_4\text{O}_8\text{P}_2\text{PdS}_2\cdot\text{H}_2\text{O}$: C, 46.73; H, 3.83; N, 5.07. Found: C, 46.80; H, 3.44; N, 4.90. IR (Nujol): 3334, 1673, 1160, 1030 cm^{-1} . ^1H NMR (CD_2Cl_2): δ = 8.98 [br s, 2H, CONH], 8.69 [s, 2H, H² py], 8.25 [br s, 2H, H⁶ py], 7.10–7.95 [m, 22H, H⁴ py + H Ph], 6.88 [br s, 2H, H⁵ py], 4.33 [br, 4H, NCH₂], 3.10 [br, 4H, PCH₂], 2.21 [br, 2H, PCH₂CH₂]. $^{31}\text{P}\{^1\text{H}\}$ NMR (CD_2Cl_2): δ = 8.12 [s]. ^{19}F NMR (CD_2Cl_2): δ = -78.96 [s]. Mp: 240 °C. Single crystals were grown from a $\text{CH}_2\text{Cl}_2/\text{MeOH}/\text{Et}_2\text{O}$ system at 4 °C by slow diffusion.

$[\{\text{Pd}(\text{PPh}_3)_2(\mu\text{-NC}_5\text{H}_4\text{-3-CH}_2\text{NHCOCNHCH}_2\text{-3-C}_5\text{H}_4\text{N})_x](\text{CF}_3\text{SO}_3)_{2x}$, **9c**. This was prepared in a similar way as for **9a** except that *cis*- $[\text{Pd}(\text{PPh}_3)_2(\text{H}_2\text{O})_2](\text{OTf})_2$ was used. Yield: 80%. Anal. Calcd for $\text{C}_{52}\text{H}_{44}\text{F}_6\text{N}_4\text{O}_8\text{P}_2\text{PdS}_2\cdot\text{H}_2\text{O}$: C, 51.30; H, 3.81; N, 4.60. Found: C, 51.30; H, 3.39; N, 4.57. IR (Nujol): 3326, 3060, 1673, 1160, 1031 cm^{-1} . ^1H NMR (acetone): δ = 8.99 [s, 2H, H² py], 8.93 [br s, 2H, CONH], 8.71 [br s, 2H, H⁶ py], 7.77 [m, 12H, H^{2,6} Ph], 7.60 [m, 6H, H⁴ Ph], 7.46 [m, 14H, H⁴ py + H^{3,5} Ph], 7.04 [m, 2H, H⁵ py], 4.40 [br s, 4H, NCH₂]. $^{31}\text{P}\{^1\text{H}\}$ NMR (acetone): δ = 27.66 [s]. ^{19}F NMR (acetone): δ = -79.07 [s]. Mp: 248 °C.

$[(\text{bu}_2\text{bipy})\text{Pd}(\mu\text{-NC}_5\text{H}_4\text{-3-CH}_2\text{NHCOCNHCH}_2\text{-3-C}_5\text{H}_4\text{N})_x](\text{CF}_3\text{SO}_3)_{2x}$, **9d**. To a suspension of $[\text{Pd}(\text{bu}_2\text{bipy})\text{Cl}_2]$ (44.5 mg, 0.100 mmol) in dry acetone (15 mL) was added silver triflate (51.2 mg, 0.200 mmol). The palladium compound quickly dissolved while a precipitate of AgCl formed. After the mixture was stirred for 2 h, the AgCl was removed by filtration and the filtrate was added to a suspension in acetone (10 mL) of *N,N'*-bis(pyridin-3-ylmethyl)oxalamide (0.027 g, 0.100 mmol). A pale yellow solution was formed. The solution was stirred for 4 h and then concentrated to ca. 5 mL, and ether was added to afford a pale yellow solid product. Yield: 93%. Anal. Calcd for $\text{C}_{34}\text{H}_{38}\text{F}_6\text{N}_6\text{O}_8\text{PdS}_2$: C, 43.29; H, 4.06; N, 8.91. Found: C, 43.42; H, 4.19; N, 8.78. IR (Nujol): 3324, 3086, 1674, 1160, 1030 cm^{-1} . ^1H NMR (acetone): poorly resolved. Mp: 288 °C.

$[\text{Pd}(\text{dppm})(\mu\text{-NC}_5\text{H}_4\text{-3-NHCO-2-NC}_5\text{H}_3\text{-6-CONH-3-C}_5\text{H}_4\text{N})_x](\text{CF}_3\text{SO}_3)_{2x}$, **10a**. This was prepared in a similar way as for **9a** except that *N,N'*-bis(pyridin-3-yl)-pyridine-2,6-dicarboxamide was used. Yield: 95%. Anal. Calcd for $\text{C}_{44}\text{H}_{35}\text{F}_6\text{N}_5\text{O}_8\text{P}_2\text{PdS}_2$: C, 47.69; H, 3.18; N, 6.32. Found: C, 47.20; H, 3.01; N, 6.32. IR (Nujol): 3292, 3083, 1692, 1162, 1029 cm^{-1} . ^1H NMR (CD_2Cl_2): δ 10.48 [s, 2H, NH], 9.46 [br s, 2H, H² py], 8.53 [br m, 4H, H^{4,6} py], 8.36 [d, 3J (HH) = 7.2 Hz, 2H, H^{3,5} pya], 8.11 [t, 3J = 7.6 Hz, 1H, H⁴ pya], 7.38–7.80 [m, 20H, H – Ph], 7.32 [br s, H⁵ py], 4.80 [br, PCH₂]. $^{31}\text{P}\{^1\text{H}\}$ NMR (CD_2Cl_2): δ = -38.12 [s]. ^{19}F NMR (CD_2Cl_2): δ = -79.26 [s]. Mp: 230 °C.

$[\text{Pd}(\text{dppp})(\mu\text{-NC}_5\text{H}_4\text{-3-NHCO-2-NC}_5\text{H}_3\text{-6-CONH-3-C}_5\text{H}_4\text{N})_x](\text{CF}_3\text{SO}_3)_{2x}$, **10b**. This was prepared in a similar way as for **10a** except that $[\text{Pd}(\text{dppp})(\text{OTf})_2]$ was used. Yield: 99%. Anal. Calcd for $\text{C}_{46}\text{H}_{39}\text{F}_6\text{N}_5\text{O}_8\text{P}_2\text{PdS}_2\cdot\text{H}_2\text{O}$: C, 47.86; H, 3.58; N, 6.07. Found: C, 47.95; H, 3.24; N, 5.84. IR (Nujol): 3306, 3092, 1692, 1161, 1030 cm^{-1} . ^1H NMR (CD_2Cl_2): δ = 10.14 [s, 2H, NH], 9.02 [s, 2H, H² py], 8.64 [d, 3J (HH) = 4 Hz, 2H, H⁶ py], 7.06 [dd, 3J (HH) = 8, 5 Hz, 2H, H⁵ py], 8.29 [overlap m, 4H, H⁴ py + H^{3,5} pya], 8.10 [t, 3J (HH) = 8 Hz, 1H, H⁴ pya], 7.26–7.82 [m, 20H, Ph], 3.38, 2.94 [br, each 2H, PCH₂], 2.48, 2.05 [br, each 1H, PCH₂CH₂]. $^{31}\text{P}\{^1\text{H}\}$ NMR (CD_2Cl_2): δ = 7.69 [s]. ^{19}F NMR (CD_2Cl_2): δ = -79.33 [s]. Mp: 245 °C, dec.

$[\{\text{Pd}(\text{PPh}_3)_2(\mu\text{-NC}_5\text{H}_4\text{-3-NHCO-2-NC}_5\text{H}_3\text{-6-CONH-3-C}_5\text{H}_4\text{N})_x](\text{CF}_3\text{SO}_3)_{2x}$, **10c**. This was prepared similarly except that $[\text{Pd}(\text{PPh}_3)_2(\text{OH})_2](\text{OTf})_2$ was used. Yield: 90%. Anal. Calcd for $\text{C}_{55}\text{H}_{43}\text{F}_6\text{N}_5\text{O}_8\text{P}_2\text{PdS}_2\cdot\text{H}_2\text{O}$: C, 52.16; H, 3.58; N, 5.53. Found: C, 52.27; H, 3.19; N, 5.89. IR (Nujol): 3287, 3083, 1694, 11631, 1030 cm^{-1} . ^1H NMR (CD_2Cl_2): δ = 9.97 [s, 2H, NH], 8.97 [d, $^3J_{\text{HH}} = 4$ Hz, 2H, H⁶ py], 8.78 [s, 2H, H² py], 8.30 [d, 3J (HH) = 8 Hz, 2H, H⁴ py], 8.23 [d, 3J (HH) = 8 Hz, 2H, H^{3,5} pya], 8.10 [t, 3J (HH) = 8 Hz, 1H, H⁴ pya], 7.24–7.78 [m, 30H, H Ph], 7.17 [dd, 3J (HH) = 8, 6 Hz, 2H, H⁵ py]. $^{31}\text{P}\{^1\text{H}\}$ NMR (CD_2Cl_2): δ = 27.25 [s]. ^{19}F NMR (CD_2Cl_2): δ = -79.25 [s]. Mp: 245 °C, dec.

$[(\text{bu}_2\text{bipy})\text{Pd}(\mu\text{-NC}_5\text{H}_4\text{-3-NHCO-2-NC}_5\text{H}_3\text{-6-CONH-3-C}_5\text{H}_4\text{N})_x](\text{CF}_3\text{SO}_3)_{2x}$, **10d**. This was prepared in a similar way as for **9d** except that *N,N'*-bis(pyridin-3-yl)pyridine-2,6-dicarboxamide was used. Yield: 88%. Anal. Calcd for $\text{C}_{37}\text{H}_{37}\text{N}_7\text{F}_6\text{O}_8\text{PdS}_2$: C, 44.79; H, 3.76; N, 9.88. Found: C, 44.62; H, 3.69; N, 9.14. IR (Nujol): 3313, 3094, 1694, 1158, 1030 cm^{-1} . ^1H NMR (DMSO-*d*₆): poorly resolved. Mp: 292 °C.

$[\{\text{Pd}(\text{dppm})(\mu\text{-NC}_5\text{H}_4\text{-4-NHCO-2-NC}_5\text{H}_3\text{-6-CONH-4-C}_5\text{H}_4\text{N})_2](\text{CF}_3\text{SO}_3)_4$, **11a**. This was prepared in a similar way as for **9a** except that *N,N'*-bis(pyridin-4-yl)pyridine-2,6-dicarboxamide was used. Yield: 90%. Anal. Calcd for $\text{C}_{44}\text{H}_{35}\text{F}_6\text{N}_5\text{O}_8\text{P}_2\text{PdS}_2$: C, 47.69; H, 3.18; N, 6.32. Found: C, 47.18; H, 3.09; N, 5.90. IR (Nujol): 3273, 1703, 1162, 1030 cm^{-1} . ^1H NMR (acetone): δ = 11.16 [s, 2H, CONH], 8.93 [d, 3J (HH) = 4 Hz, 4H, H^{2,6} py], 8.39 [d, 3J (HH) = 8 Hz, 2H, H^{3,5} pya], 8.33 [t, 3J (HH) = 8 Hz, 1H, H⁴ pya], 8.04 [m, 12H, H^{3,5} py + H^{2,6} Ph], 7.73 [m, 4H, H⁴ B Ph], 7.61 [m, 8H, H^{3,5} Ph], 5.29 [t, $^2J_{\text{PH}} = 12$ Hz, 2H, PCH₂]. $^{31}\text{P}\{^1\text{H}\}$ NMR (acetone): δ = -39.92 [s]. ^{19}F NMR (acetone): δ = -79.21 [s]. Mp: 263 °C, dec.

$[\{\text{Pd}(\text{dppp})(\mu\text{-NC}_5\text{H}_4\text{-4-NHCO-2-NC}_5\text{H}_3\text{-6-CONH-4-C}_5\text{H}_4\text{N})_x](\text{CF}_3\text{SO}_3)_{2x}$, **11b**. This was prepared similarly except that $[\text{Pd}(\text{dppp})(\text{OTf})_2]$ was used. Yield: 97%. Anal. Calcd for $\text{C}_{46}\text{H}_{39}\text{F}_6\text{N}_5\text{O}_8\text{P}_2\text{-PdS}_2\cdot\text{H}_2\text{O}$: C, 47.86; H, 3.58; N, 6.07. Found: C, 47.96; H, 3.25; N, 6.13. IR (Nujol): 3265, 1700, 1163, 1026 cm^{-1} . ^1H NMR (acetone): δ = 10.85 [s, 2H, CONH], 8.72 [d, 3J (HH) = 6 Hz, 4H, H^{2,6} py], 8.28 [m, 3H, H^{3,4,5} pya], 7.38–8.12 [br, 24H, H^{3,5} py + H Ph], 3.42 [br, PCH₂], 2.40 [br, PCH₂CH₂]. $^{31}\text{P}\{^1\text{H}\}$ NMR (acetone): δ = 9.36 [s]. ^{19}F NMR (acetone): δ = -79.16 [s]. Mp: 308 °C, dec.

$[\{\text{Pd}(\text{PPh}_3)_2(\mu\text{-NC}_5\text{H}_4\text{-4-NHCO-2-NC}_5\text{H}_3\text{-6-CONH-4-C}_5\text{H}_4\text{N})\}_x(\text{CF}_3\text{SO}_3)_2]_{2x}$, **11c**. This was prepared similarly except that $[\text{Pd}(\text{PPh}_3)_2(\text{OH}_2)_2](\text{OTf})_2$ was used. Yield: 86%. Anal. Calcd for $\text{C}_{55}\text{H}_{43}\text{F}_6\text{N}_5\text{O}_8\text{P}_2\text{PdS}_2\cdot\text{H}_2\text{O}$: C, 52.16; H, 3.58; N, 5.53. Found: C, 52.20; H, 3.26; N, 5.31. IR (Nujol): 3292, 3075, 1701, 1159, 1030 cm^{-1} . ^1H NMR (acetone): δ = 10.89 [s, 2H, CONH], 8.72 [d, $^3J(\text{HH})$ = 6 Hz, 4H, $\text{H}^{2,6}$ py], 8.29 [m, 3H, $\text{H}^{3,4,5}$ pya], 7.48–7.80 [m, 34H, $\text{H}^{3,5}$ py + H Ph]. $^{31}\text{P}\{^1\text{H}\}$ NMR (acetone): δ = 27.62. ^{19}F NMR (acetone): δ = -79.12 [s]. Mp: 263 °C, dec.

$[(\text{bu}_2\text{bipy})\text{Pd}(\mu\text{-NC}_5\text{H}_4\text{-4-NHCO-2-NC}_5\text{H}_3\text{-6-CONH-4-C}_5\text{H}_4\text{N})]_x(\text{CF}_3\text{SO}_3)_2]_{2x}$, **11d**. This was prepared by the same procedure as for **9d** except that *N,N'*-bis(pyridin-4-yl)pyridine-2,6-dicarboxamide was used. Yield: 93%. Anal. Calcd for $\text{C}_{37}\text{H}_{37}\text{N}_7\text{F}_6\text{O}_8\text{PdS}_2$: C, 44.79; H, 3.76; N, 9.88. Found: C, 44.21; H, 3.94; N, 9.47. IR (Nujol): 3269, 3077, 1700, 1163, 1030 cm^{-1} . ^1H NMR (acetone): δ = 11.39 [s, 2H, CONH], 9.31 [d, $^3J(\text{HH})$ = 7 Hz, 4H, $\text{H}^{2,6}$ py], 8.81 [s, 2H, H^5 bu_2bipy], 8.45 [d, $^3J(\text{HH})$ = 7 Hz, 2H, $\text{H}^{3,5}$ pya], 8.38 [t, $^3J(\text{HH})$ = 8 Hz, 1H, H^4 bz], 8.31 [br s, 4H, $\text{H}^{3,5}$ py], 8.03 [d, $^3J_{\text{HH}}$ = 6 Hz, 2H, H^6 bu_2bipy], 7.80 [dd, $^3J(\text{HH})$ = 6 Hz, $^4J(\text{HH})$ = 6 Hz, 2H, H^6 bu_2bipy], 1.47 [s, 18H, Bu]. Mp: 240 °C, dec.

$[\{\text{Pd}(\text{dppm})(\mu\text{-NC}_5\text{H}_4\text{-3-NHCO-1-C}_5\text{H}_4\text{-3-CONH-3-C}_5\text{H}_4\text{N})\}_x(\text{CF}_3\text{SO}_3)_2]_{2x}$, **12a**. This was prepared in a similar way as for **9a** except that *N,N'*-bis(pyridin-3-yl)isophthalamide was used. Yield: 95%. Anal. Calcd for $\text{C}_{45}\text{H}_{36}\text{F}_6\text{N}_4\text{O}_8\text{P}_2\text{PdS}_2\cdot\text{H}_2\text{O}$: C, 48.03; H, 3.40; N, 4.98. Found: C, 48.15; H, 3.09; N, 5.03. IR (Nujol): 3320, 3086, 1685, 1164, 1030 cm^{-1} . ^1H NMR (acetone): δ = 9.95 [s, 2H, CONH], 9.72 [s, 2H, H^2 py], 8.72 [br s, 2H, H^6 py], 8.38 [br s, 3H, H^4 py + H^2 bz], 8.13 [br s, 2H, $\text{H}^{4,6}$ bz], 7.52–8.10 [m, 23H, H^5 py + H^5 bz + H ph], 5.28 [t, $^2J(\text{PH})$ = 12.0 Hz, 2H, PCH_2]. $^{31}\text{P}\{^1\text{H}\}$ NMR (acetone): δ = -39.07 [s]. ^{19}F NMR (acetone): δ = -79.31 [s]. Mp: 240 °C, dec.

$[\{\text{Pd}(\text{dppp})(\mu\text{-NC}_5\text{H}_4\text{-3-NHCO-1-C}_5\text{H}_4\text{-3-CONH-3-C}_5\text{H}_4\text{N})\}_x(\text{CF}_3\text{SO}_3)_2]_{2x}$, **12b**. This was prepared in a similar way as for **12a** except that $[\text{Pd}(\text{dppp})(\text{OTf})_2]$ was used. A white product was obtained. Yield: 91%. Anal. Calcd for $\text{C}_{47}\text{H}_{40}\text{F}_6\text{N}_4\text{O}_8\text{P}_2\text{PdS}_2\cdot\text{H}_2\text{O}$: C, 48.95; H, 3.67; N, 4.86. Found: C, 48.92; H, 3.47; N, 4.54. IR (Nujol): 3314, 1684, 1162, 1030 cm^{-1} . ^1H NMR (CD_2Cl_2): δ = 9.68 [s, 2H, CONH], 9.25 [s, 2H, H^2 py], 8.76 [d, $^3J(\text{HH})$ = 8 Hz, 2H, H^6 py], 8.13 [d, $^3J(\text{HH})$ = 4 Hz, 2H, H^4 py], 6.82 [dd, $^3J(\text{HH})$ = 8, 6 Hz, 2H, H^5 py], 8.21 [s, 1H, H^2 bz], 7.96 [d, $^3J(\text{HH})$ = 8 Hz, 2H, $\text{H}^{4,6}$ bz], 7.53 [t, $^3J(\text{HH})$ = 8 Hz, H, H^5 bz], 8.01 [br, 4H, $\text{H}^{2,6}$ Ph], 7.58 [m, 6H, $\text{H}^{3,4,5}$ Ph], 7.37 [br, 4H, $\text{H}^{2,6}$ Ph], 7.30 [m, 2H, H^4 Ph], 7.19 [m, 4H, $\text{H}^{3,5}$ Ph], 3.64, 2.81 [m, each 2H, PCH_2], 2.70, 1.78 [m, each 1H, PCH_2CH_2]. $^{31}\text{P}\{^1\text{H}\}$ NMR (CD_2Cl_2): δ = 7.98 [s]. ^{19}F NMR (CD_2Cl_2): δ = -79.12 [s]. Mp: 225 °C.

$[\{\text{Pd}(\text{PPh}_3)_2(\mu\text{-NC}_5\text{H}_4\text{-3-NHCO-1-C}_5\text{H}_4\text{-3-CONH-3-C}_5\text{H}_4\text{N})\}_x(\text{CF}_3\text{SO}_3)_2]_{2x}$, **12c**. This was prepared in a similar way as for **12a** except that *cis*- $[\text{Pd}(\text{PPh}_3)_2(\text{OH}_2)_2](\text{OTf})_2$ was used. Yield: 85%. Anal. Calcd for $\text{C}_{56}\text{H}_{44}\text{F}_6\text{N}_4\text{O}_8\text{P}_2\text{PdS}_2\cdot\text{H}_2\text{O}$: C, 53.15; H, 3.66; N, 4.43. Found: C, 53.33; H, 3.15; N, 4.38. IR (Nujol): 3306, 3065, 1684, 1164, 1031 cm^{-1} . ^1H NMR (CD_2Cl_2): δ = 9.42 [s, 2H, CONH], 8.78 [m, 4H, $\text{H}^{4,6}$ py], 8.65 [s, 2H, H^2 py], 8.10 [s, 1H, H^2 bz], 7.86 [d, $^3J(\text{HH})$ = 8 Hz, 2H, $\text{H}^{4,6}$ -bz], 7.28–7.80 [m, 30H, H ph], 7.07 [dd, $^3J(\text{HH})$ = 8, 6 Hz, 2H, H^5 py]. $^{31}\text{P}\{^1\text{H}\}$ NMR (CD_2Cl_2): δ 27.27 [s]. ^{19}F NMR (CD_2Cl_2): δ = -79.16 [s]. Mp: 240 °C, dec.

$[(\text{bu}_2\text{bipy})\text{Pd}(\mu\text{-NC}_5\text{H}_4\text{-3-NHCO-1-C}_5\text{H}_4\text{-3-CONH-3-C}_5\text{H}_4\text{N})]_x(\text{CF}_3\text{SO}_3)_2]_{2x}$, **12d**. This was prepared in a similar way as for **9d** except that *N,N'*-bis(pyridin-3-yl)isophthalamide was used. Yield: 90%. Anal. Calcd for $\text{C}_{38}\text{H}_{38}\text{N}_6\text{F}_6\text{O}_8\text{PdS}_2$: C, 46.04; H, 3.86; N, 8.48. Found: C, 45.79; H, 4.07; N, 8.10. IR (Nujol): 3339, 3103, 1686, 1162, 1030 cm^{-1} . ^1H NMR ($\text{DMSO}-d_6$): poorly resolved. Mp: 245 °C, dec.

$[\{\text{Pd}(\text{dppm})(\mu\text{-NC}_5\text{H}_4\text{-4-NHCO-1-C}_5\text{H}_4\text{-3-CONH-4-C}_5\text{H}_4\text{N})\}_x(\text{CF}_3\text{SO}_3)_2]_{2x}$, **14a**. This was prepared in a similar way as for **9a** except that *N,N'*-bis(pyridin-4-yl)isophthalamide was used. Yield: 81.0%. Anal. Calcd for $\text{C}_{45}\text{H}_{36}\text{F}_6\text{N}_4\text{O}_8\text{P}_2\text{PdS}_2$: C, 48.81; H, 3.28; N, 5.06. Found: C, 48.44; H, 3.28; N, 5.30. IR (Nujol): 3265, 3176, 3076, 1695, 1164, 1030 cm^{-1} . ^1H NMR ($\text{DMSO}-d_6$): δ = 11.09 [s, 2H, CONH], 8.59 [br s, 4H, $\text{H}^{2,6}$ py], 8.29 [br s, 1H, H^2 bz], 8.10 [br s, 2H, $\text{H}^{4,6}$ bz], 7.42–7.90 [m, 25H, $\text{H}^{3,5}$ py + H^5 bz + H Ph], 5.13 [t, $^2J(\text{PH})$ = 12 Hz, 2H, PCH_2]. $^{31}\text{P}\{^1\text{H}\}$ NMR ($\text{CD}_3\text{-OD}$): δ = -39.84 [s]. Mp: 260 °C.

$[\{\text{Pd}(\text{dppp})(\mu\text{-NC}_5\text{H}_4\text{-4-NHCO-1-C}_5\text{H}_4\text{-3-CONH-4-C}_5\text{H}_4\text{N})\}_x(\text{CF}_3\text{SO}_3)_2]_{2x}$, **14b**. This was prepared in a similar way as for **14a** except that $[\text{Pd}(\text{dppp})(\text{OTf})_2]$ was used. Yield: 99%. Anal. Calcd for $\text{C}_{47}\text{H}_{40}\text{F}_6\text{N}_4\text{O}_8\text{P}_2\text{PdS}_2$: C, 49.72; H, 3.55; N, 4.93. Found: C, 49.32; H, 3.47; N, 5.07. IR (Nujol): 3273, 1704, 1166, 1029 cm^{-1} . ^1H NMR (acetone): δ = 10.05 [s, 2H, CONH], 8.64 [d, $^3J(\text{HH})$ = 5 Hz, 4H, $\text{H}^{2,6}$ py], 7.52 [d, $^3J(\text{HH})$ = 7 Hz, 4H, $\text{H}^{3,5}$ py], 8.17 [s, 1H, H^2 bz], 8.01 [d, $^3J(\text{HH})$ = 8 Hz, 2H, $\text{H}^{4,6}$ bz], 7.66 [t, $^3J(\text{HH})$ = 8 Hz, 1H, H^5 bz], 7.87 [m, 8H, $\text{H}^{2,6}$ Ph], 7.46 [m, 8H, $\text{H}^{3,5}$ Ph], 7.55 [m, 4H, H^4 Ph], 3.37 [br, 4H, PCH_2], 2.32 [br, 2H, PCH_2CH_2]. $^{31}\text{P}\{^1\text{H}\}$ NMR (acetone): δ = 9.38 [s]. ^{19}F NMR (acetone): δ = -79.40 [s]. Mp: 270 °C, dec. Single crystals were grown from acetone/methanol/hexane at 4 °C.

$[\{\text{Pd}(\text{PPh}_3)_2(\mu\text{-NC}_5\text{H}_4\text{-4-NHCO-2-C}_5\text{H}_4\text{-6-CONH-4-C}_5\text{H}_4\text{N})\}_x(\text{CF}_3\text{SO}_3)_2]_{2x}$, **13a**. This was prepared in a similar way as for **9c** except that *N,N'*-bis(pyridin-4-yl)isophthalamide was used. Yield: 75%. Anal. Calcd for $\text{C}_{56}\text{H}_{44}\text{F}_6\text{N}_4\text{O}_8\text{P}_2\text{PdS}_2\cdot\text{H}_2\text{O}$: C, 53.15; H, 3.66; N, 4.43. Found: C, 53.20; H, 3.16; N, 4.79. IR (Nujol): 3266, 3176, 3086, 1696, 1164, 1030 cm^{-1} . ^1H NMR (CD_2Cl_2): δ = 10.00 [s, 2H, NH], 8.68 [d, $^3J(\text{HH})$ = 6 Hz, 4H, $\text{H}^{2,6}$ py], 8.17 [s, 1H, H^2 bz], 8.00 [d, $^3J(\text{HH})$ = 8 Hz, 2H, $\text{H}^{4,6}$ bz], 7.66 [t, $^3J(\text{HH})$ = 8 Hz, 1H, H^5 bz], 7.55 [d, $^3J(\text{HH})$ = 6 Hz, 4H, $\text{H}^{3,5}$ py], 7.80 [m, 12H, $\text{H}^{2,6}$ Ph], 7.61 [m, 6H, H^4 Ph], 7.47 [m, 12H, $\text{H}^{3,5}$ Ph]. $^{31}\text{P}\{^1\text{H}\}$ NMR (CD_2Cl_2): δ 27.60 [s]. ^{19}F NMR (CD_2Cl_2): δ = -79.44 [s]. Mp: 243 °C, dec.

$[(\text{bu}_2\text{bipy})\text{Pd}(\mu\text{-NC}_5\text{H}_4\text{-4-NHCO-1-C}_5\text{H}_4\text{-3-CONH-4-C}_5\text{H}_4\text{N})]_x(\text{CF}_3\text{SO}_3)_2]_{2x}$, **13b**. This was prepared by the same procedure as for **9d** except that *N,N'*-bis(pyridin-4-yl)isophthalamide was used. Yield: 95%. Anal. Calcd for $\text{C}_{38}\text{H}_{38}\text{N}_6\text{F}_6\text{O}_8\text{PdS}_2$: C, 46.04; H, 3.86; N, 8.48. Found: C, 45.71; H, 3.95; N, 8.03. IR (Nujol): 3286, 3176, 3087, 1696, 1163, 1030 cm^{-1} . ^1H NMR (acetone): δ 10.54 [s, 2H, CONH], 9.28 [d, 4H, $^3J(\text{HH})$ = 6 Hz, $\text{H}^{2,6}$ Py], 8.18 [d, $^3J(\text{HH})$ = 6 Hz, 4H, $\text{H}^{3,5}$ Py], 8.50 [s, 1H, H^2 bz], 8.14 [d, $^3J(\text{HH})$ = 8 Hz, 2H, $\text{H}^{4,6}$ bz], 7.77 [t, $^3J(\text{HH})$ = 8 Hz, 1H, H^5 bz], 8.82 [s, 2H, H^3 bu_2bipy], 7.95 [d, $^3J(\text{HH})$ = 6 Hz, 2H, H^6 bu_2bipy], 7.79 [dd, $^3J(\text{HH})$ = 6 Hz, $^4J(\text{HH})$ = 2 Hz, 2H, H^5 bu_2bipy], 1.45 [s, 18H, Bu]. ^{19}F NMR (acetone): δ = -79.56 [s]. Mp: 194 °C.

X-ray Structure Determinations. Data were collected using a Nonius Kappa-CCD diffractometer using COLLECT (Nonius, 1998) software. The unit cell parameters were calculated and refined from the full data set. Crystal cell refinement and data reduction were carried out using the Nonius DENZO package. The data were scaled using SCALEPACK (Nonius, 1998). The SHELXTL 5.1 (Sheldrick, G. M., Madison, WI) program package was used to solve and refine the structure by direct methods. A summary of crystallographic data can be found in Table 5; there were problems in some cases through weak diffraction or crystal twinning.

$[\{(\text{bu}_2\text{bipy})\text{Pt}(\mu\text{-NC}_5\text{H}_4\text{-4-CONH-4-C}_5\text{H}_4\text{N})\}_3(\text{CF}_3\text{SO}_3)_6\cdot\text{acetone}\cdot 3\text{H}_2\text{O}$, **7b**. The cation was well-defined, but there was much disorder of the anions and solvent molecules. Only the platinum atom and two anions were refined anisotropically.

$[\{\text{Pd}(\text{dppm})(\mu\text{-NC}_5\text{H}_4\text{-3-CH}_2\text{NHCOCONHCH}_2\text{-3-C}_5\text{H}_4\text{N})\}_2(\text{CF}_3\text{SO}_3)_4\cdot 2(\text{acetone})$, **9a**. One anion was disordered over two

Table 5. Crystal and Refinement Data

	7b·Me ₂ CO·3H ₂ O	9a·2Me ₂ CO	11a·4.25Me ₂ CO	14b·Me ₂ CO·MeOH
formula	C ₉₆ H ₁₀₅ F ₁₈ N ₁₅ O ₂₅ Pt ₃ S ₆	C ₄₄ H ₄₂ F ₆ N ₄ O ₉ P ₂ PdS ₂	C _{100.75} H _{95.50} F ₁₂ N ₁₀ O _{20.25} P ₄ Pd ₂ S ₄	C ₅₁ H ₅₀ F ₆ N ₄ O ₁₀ P ₂ PdS ₂
fw	2988.58	1117.28	2463.29	1225.41
temp (K)	200(2)	200(2)	200(2)	200(2)
λ (Å)	0.710 73	0.710 73	0.710 73	0.710 73
space group	<i>P</i> 1	<i>P</i> 2 ₁ / <i>c</i>	<i>P</i> 2 ₁ / <i>n</i>	<i>P</i> 2 ₁ / <i>n</i>
<i>a</i> (Å)	15.2398(9)	19.0369(8)	20.08235(2)	16.3005(3)
<i>b</i> (Å)	18.1540(10)	11.8408(4)	18.8219(2)	20.1563(4)
<i>c</i> (Å)	23.4615(13)	21.9056(9)	30.0903(5)	17.2929(5)
α (deg)	79.115(3)	90	90	90
β (deg)	84.232(3)	95.419(2)	91.361(1)	92.835(1)
γ (deg)	77.554(3)	90	90	90
<i>V</i> (Å ³)	6212.2(6)	4915.7(3)	11337.2(3)	5674.8(2)
<i>Z</i>	2	4	4	4
<i>D</i> _{calc} (g/cm ³)	1.598	1.510	1.443	1.434
μ (mm ⁻¹)	3.567	0.607	0.536	0.534
<i>F</i> (000)	2956	2272	5024	2504
θ range (deg)	3.40–21.99	2.69–27.48	2.55–27.47	2.63–25.19
range <i>h</i>	–16 to 16	–24 to 24	–24 to 24	–19 to 19
range <i>k</i>	–19 to 19	–13 to 15	–24 to 24	–24 to 24
range <i>l</i>	–24 to 24	–28 to 28	–39 to 39	–20 to 20
reflns colld	43 817	26 728	97 553	44 863
unique reflns	15 006	10 882	28 701	17 231
max/min trans	0.7168, 0.5661	0.9145, 0.8022	0.8889, 0.7394	0.9124, 0.8435
R [<i>I</i> > 2σ(<i>I</i>)] ^a				
R1	0.0960	0.0450	0.0980	0.0732
wR2	0.2620	0.1099	0.2315	0.1681

$$^a R1 = \sum ||F_o| - |F_c|| / \sum |F_o|; wR2 = [\sum w(F_o^2 - F_c^2)^2 / \sum w(F_o^2)^2]^{1/2}.$$

positions and refined to 60:40 occupancy. All heavy atoms were refined anisotropically.

[{Pd(dppm)(μ-NC₅H₄-4-NHCO-2-NC₅H₃-6-CONH-4-C₅H₄N)}₂](CF₃SO₃)₄·4.25(acetone), **11a**. The crystal was twinned about the [100] direct axis, but all heavy atoms were well-defined and were refined anisotropically in the twin model. There were 2 acetones at full occupancy, and three others at 0.75 occupancy.

[{Pd(dppp)(μ-NC₅H₄-4-NHCO-1-C₅H₄-3-CONH-4-C₅H₄N)}_x](CF₃SO₃)_{2x}·acetone·MeOH, **14b**. The crystal was twinned about the [101] reciprocal axis. All non-hydrogen atoms were refined

anisotropically. The phenyl groups were constrained to be perfect hexagons, and the acetone of solvation was constrained to be FLAT.

Acknowledgment. We thank the NSERC (Canada) for financial support. R.J.P. thanks the Government of Canada for a Canada Research Chair.

Supporting Information Available: Tables of X-ray data in CIF format. This material is available free of charge via the Internet at <http://pubs.acs.org>.

IC020322Z