

## IR Spectroelectrochemical Study on $U^{VI}O_2^+$ Complex: First Evidence for Weakening of U=O Bond Strength in Uranyl Moiety with Reduction from U(VI) to U(V)

Koichiro Mizuoka and Yasuhisa Ikeda\*

Research Laboratory for Nuclear Reactors, Tokyo Institute of Technology, O-okayama, Meguro-ku, Tokyo 152-8550, Japan

Received March 5, 2003

We have obtained the first evidence that the U=O bond strength in uranyl moiety is weakened with the reduction from  $U^{VI}O_2^{2+}$  to  $U^{V}O_2^+$  from the IR spectroelectrochemical study on  $U^{VI}O_2(\text{saloph})\text{-DMSO}$  and  $[U^{VI}O_2(\text{saloph})\text{DMSO}]^-$  (saloph = *N,N'*-disalicylidene-*o*-phenylenediaminate, DMSO = dimethyl sulfoxide) complexes with the thin layer electrode cell for IR measurements.

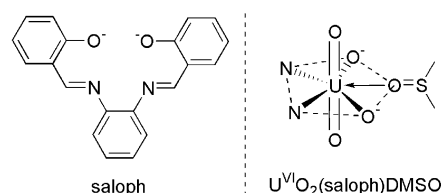

Figure 1. Schematic structures of saloph and  $U^{VI}O_2(\text{saloph})\text{DMSO}$ .

Uranium(V) is unstable in solutions, because of the disproportionation. Therefore, the properties of U(V) species have been still uncertain, especially those on the vibrations in  $U^{V}O_2^+$  species, despite a large amount of such data concerning  $U^{VI}O_2^{2+}$  complexes.<sup>1</sup> On the other hand, the vibrational properties of other actinide -yl type species ( $AnO_2^{n+}$ , An = Np or Am,  $n = 1$  or 2) have been reported by Jones et al.<sup>2</sup> According to them, changes in oxidation states from  $An^{VI}O_2^{2+}$  to  $An^{V}O_2^+$  cause lower shift of O=An=O asymmetry stretching ( $\nu_3$ ) in  $AnO_2^{n+}$  by more than  $100\text{ cm}^{-1}$ ; i.e., the reduction from An(VI) to An(V) weakens An=O bond strength. Hence, it is expected that the similar phenomenon is observed in the case of An = U.

Best et al. have reported the IR spectroelectrochemical studies on  $U^{VI}O_2^{2+}$  species in aqueous system.<sup>3</sup> However, in their aqueous system, the electrochemical reduction of  $U^{VI}O_2^{2+}$  is irreversible, and hence, the electron stoichiometry and the reduction products have not been determined.

Recently, we have studied the electrochemical and spectroelectrochemical properties of the uranyl complex with *N,N'*-disalicylidene-*o*-phenylenediaminate (saloph) and dimethyl sulfoxide (DMSO) as ligands  $[U^{VI}O_2(\text{saloph})\text{DMSO}]^-$

see Figure 1].<sup>4</sup> In such studies, we revealed that  $U^{VI}O_2(\text{saloph})\text{DMSO}$  in DMSO is quasireversibly reduced to  $[U^{V}O_2(\text{saloph})\text{DMSO}]^-$  and that the formal potential ( $E^\circ$ ) of this redox couple is  $-1.550\text{ V}$  versus ferrocene/ferrocenium ion redox couple ( $Fc/Fc^+$ ). Furthermore, we found out that  $[U^{V}O_2(\text{saloph})\text{DMSO}]^-$  can stably exist in DMSO and has characteristic absorption bands at around 750 and 900 nm in the UV–visible abs spectrum. In the present study, to reveal the properties on the vibrations in the  $U^{V}O_2^+$  complex, we tried to observe the IR spectrum of  $[U^{V}O_2(\text{saloph})\text{DMSO}]^-$  complex in DMSO by using the IR spectroelectrochemical method with the thin layer electrode cell for IR measurements (IRTLE, see Figure 2). All potentials reported here are versus  $Fc/Fc^+$ .

The IR spectra of  $U^{VI}O_2(\text{saloph})\text{DMSO}$  in DMSO were measured with the standard liquid cell (SL) and IRTLE. We carried out data accumulation 40 and 500 times for IR measurements with SL and IRTLE, respectively. The resulting IR spectra are shown in Figure 3. In the IR spectrum measured with SL (black line in Figure 3), the characteristic peaks for azomethine stretching ( $\nu_{C=N}$ ) and  $\nu_3$  of  $U^{VI}O_2(\text{saloph})\text{DMSO}$  are observed at  $1605$  and  $895\text{ cm}^{-1}$ , respectively. These assignments are supported by the results of Cattalini et al.<sup>5</sup> These peaks are also observed in the IR spectrum measured with IRTLE (red line in Figure 3). Therefore, it was confirmed that IRTLE can function as well as SL. Since the ratio of signal-to-noise for the IR spectra

\* To whom correspondence should be addressed. E-mail: yiked@nr.titech.ac.jp. Phone and fax: +81-3-5734-3061.

- (1) (a) Jones, L. H. *Spectrochim. Acta* **1958**, *10*, 395–403. (b) Jones, L. H. *Spectrochim. Acta* **1958**, *11*, 409–411. (c) MacGlynn, S. P.; Smith, J. K.; Neely, W. C. *J. Chem. Phys.* **1961**, *35*, 105–116. (d) Glebov, V. A. *Koord. Khim.* **1981**, *7*, 388–395. (e) Glebov, V. A. *Koord. Khim.* **1982**, *8*, 970–976.
- (2) Jones, L. H.; Penneman, R. A. *J. Chem. Phys.* **1953**, *21*, 542–544.
- (3) Best, S. P.; Clark, R. J. H.; Cooney, R. P. *Inorg. Chim. Acta* **1988**, *145*, 141–147.

(4) Mizuoka, K.; Kim, S.-Y.; Hasegawa, M.; Hoshi, T.; Uchiyama, G.; Ikeda, Y. *Inorg. Chem.* **2003**, *42*, 1031–1038.

(5) Cattalini, L.; Degetto, S.; Vidali, M.; Vigato, P. A. *Inorg. Chim. Acta* **1972**, *6*, 173–176.

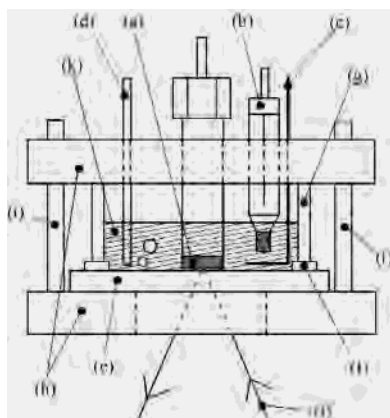

**Figure 2.** Scheme of IRTLE: (a) Pt working electrode, (b) Ag/Ag<sup>+</sup> reference electrode, (c) Pt counter electrode, (d) Ar gas inlet, (e) NaCl window, (f) PTFE rubber packing, (g) glass cell, (h) PTFE frames, (i) PTFE screws, (j) HeNe laser from FTIR, and (k) sample solution.

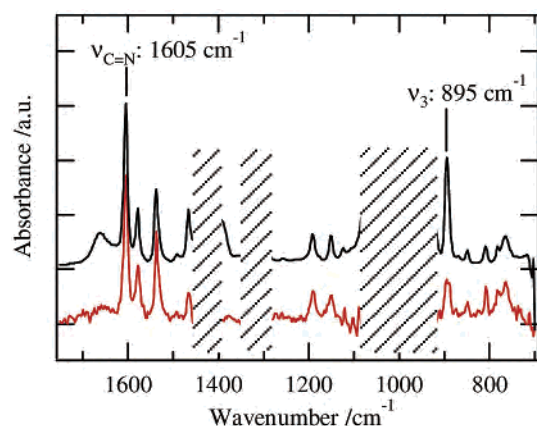

**Figure 3.** IR spectra of U<sup>VI</sup>O<sub>2</sub>(saloph)DMSO in DMSO measured with SL (black) and IRTLE (red). Hatched parts: absorption regions of DMSO as solvent.

with IRTLE is not good, the  $\nu_3$  peak at 895 cm<sup>-1</sup> is split by noise.

In order to examine the vibrational changes with the reduction of U<sup>VI</sup>O<sub>2</sub>(saloph)DMSO, the IR spectra were measured at various applied potentials in the range from 0 to -1.73 V with IRTLE. The resulting IR spectra are shown in Figure 4. The clear isosbestic points are observed at 1577 and 1531 cm<sup>-1</sup> in Figure 4a. This indicates that only one equilibrium exists in this system, i.e., a redox equilibrium. In Figure 4b, the  $\nu_3$  peak due to U<sup>VI</sup>O<sub>2</sub>(saloph)DMSO at 895 cm<sup>-1</sup> disappears, and a new peak appears at 770 cm<sup>-1</sup> with an increase in negative potential. These results suggest that the changes of IR spectra in Figure 4 correspond to eq 1.

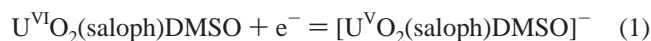

In order to examine the validity of this approach, the Nernstian plot was performed by using the absorbancies at 770 cm<sup>-1</sup>. As a result, the electron stoichiometry and  $E^\circ$  values were evaluated as 0.9 and -1.52 V, respectively. These values are consistent with those in our recent study.<sup>4</sup> Furthermore, after the reduction at -1.73 V, the IR spectrum was measured at -1.33 V. The resulting IR spectrum was consistent with that of U<sup>VI</sup>O<sub>2</sub>(saloph)DMSO. Thus, it is

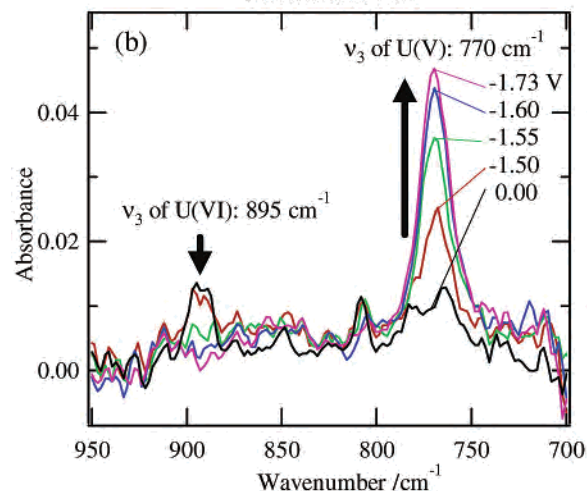
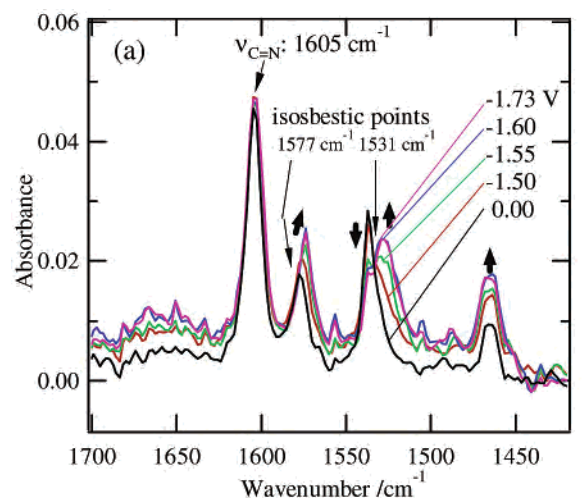

**Figure 4.** IR spectra measured at various applied potentials for U<sup>VI</sup>O<sub>2</sub>(saloph)DMSO (8 mM) in DMSO. Wavenumber range: (a) 1700–1420 cm<sup>-1</sup>, (b) 950–700 cm<sup>-1</sup>. Peak at 895 cm<sup>-1</sup> is split by noise.

concluded that the IR spectral changes in Figure 4 correspond to eq 1 and that the IR spectrum measured at -1.73 V is assigned to [U<sup>V</sup>O<sub>2</sub>(saloph)DMSO]<sup>-</sup>. This is first observation of the IR spectrum of the pure U(V) complex.

The uranium in U<sup>VI</sup>O<sub>2</sub><sup>2+</sup> has no 5f electron, while that in U<sup>V</sup>O<sub>2</sub><sup>+</sup> has one 5f electron. Since the electron density on U<sup>V</sup> atom is larger than that on U<sup>VI</sup> atom, the electric repulsion between the uranium atom and the oxygen atom in U<sup>V</sup>O<sub>2</sub><sup>+</sup> should be stronger than that in U<sup>VI</sup>O<sub>2</sub><sup>2+</sup>. Thus, it is expected that the U=O bond strength in U<sup>V</sup>O<sub>2</sub><sup>+</sup> is weaker than that in U<sup>VI</sup>O<sub>2</sub><sup>2+</sup>; i.e., the  $\nu_3$  peak is shifted to a lower wavenumber with the reduction from U<sup>VI</sup>O<sub>2</sub><sup>2+</sup> to U<sup>V</sup>O<sub>2</sub><sup>+</sup>. Hence, the peak at 770 cm<sup>-1</sup> in the IR spectrum of [U<sup>V</sup>O<sub>2</sub>(saloph)DMSO]<sup>-</sup> can be assigned to the  $\nu_3$  peak of this U(V) complex.

The vibrational properties of the AnO<sub>2</sub><sup>n+</sup> ( $n = 1$  or 2) ion are collected in Table 1. The  $\Delta\nu_3$  value for An = U and the  $F_{\text{UO}}$  values for U<sup>VI</sup>O<sub>2</sub>(saloph)DMSO and [U<sup>V</sup>O<sub>2</sub>(saloph)DMSO]<sup>-</sup> are very similar to those of the other An<sup>VI</sup>O<sub>2</sub><sup>2+</sup> and An<sup>V</sup>O<sub>2</sub><sup>+</sup> species, respectively. Moreover, Docrat et al. reported that the U=O distance of uranyl moiety in [U<sup>V</sup>O<sub>2</sub>(CO<sub>3</sub>)<sub>3</sub>]<sup>5-</sup> is 0.10 Å longer than that in [U<sup>VI</sup>O<sub>2</sub>(CO<sub>3</sub>)<sub>3</sub>]<sup>4-</sup> from the X-ray absorption spectroscopic study.<sup>6</sup> Their results were supported by the theoretical studies by Gagliardi et al.<sup>7</sup>

## COMMUNICATION

Therefore, our assignment of peak at  $770\text{ cm}^{-1}$  to the  $\nu_3$  of  $[\text{U}^{\text{V}}\text{O}_2(\text{saloph})\text{DMSO}]^-$  should be reasonable.

On the other hand, the peaks due to saloph ligand at 1605, 1577, 1537, 1465, 1190, and  $1149\text{ cm}^{-1}$  have no changes or slightly shift in the range of less than  $10\text{ cm}^{-1}$ , despite the drastic changes of the  $\nu_3$  peak in uranyl moiety. This suggests that the redox reaction of the uranyl complex has little influence on the coordination structures of saloph. The vibrational behaviors of coordinated DMSO with this redox reaction cannot be observed, because of the overlapping with the absorption region of DMSO as solvent.

(6) Docrat, T. I.; Mosselmans, J. F. W.; Charnock, J. M.; Whiteley, M. W.; Collison, D.; Livens, F. R.; Jones, C.; Edmiston, M. J. *Inorg. Chem.* **1999**, *38*, 1879–1882.

(7) Gagliardi, L.; Grenthe, I.; Roos, B. O. *Inorg. Chem.* **2001**, *40*, 2976–2978.

**Table 1.** Vibrational Properties of  $\text{AnO}_2^{n+}$  ( $n = 1$  or  $2$ ) Complexes

An(V), (VI)	$\nu_3/\text{cm}^{-1}$	$\Delta\nu_3/\text{cm}^{-1}$ <sup>a</sup>	$F_{\text{AnO}}/\text{mdyne}\cdot\text{\AA}^{-1}$ <sup>b</sup>
$[\text{U}^{\text{V}}\text{O}_2(\text{saloph})\text{DMSO}]^-$	770	125	5.31
$\text{U}^{\text{VI}}\text{O}_2(\text{saloph})\text{DMSO}$	895		7.17
$\text{Np}^{\text{V}}\text{O}_2^+$	$824 \pm 4^c$	$145 \pm 5$	$5.65 \pm 0.06^c$
$\text{Np}^{\text{VI}}\text{O}_2^{2+}$	$969 \pm 1^c$		$7.81 \pm 0.02^c$
$\text{Am}^{\text{V}}\text{O}_2^+$	$832 \pm 2^c$	$107 \pm 3$	$5.77 \pm 0.03^c$
$\text{Am}^{\text{VI}}\text{O}_2^{2+}$	$939 \pm 1^c$		$7.35 \pm 0.02^c$

<sup>a</sup> Differences between the  $\nu_3$  of  $\text{An}^{\text{V}}\text{O}_2^+$  and  $\text{An}^{\text{VI}}\text{O}_2^{2+}$  complexes.  
<sup>b</sup> Force constants of  $\text{An}=\text{O}$  bond. <sup>c</sup> Data from ref 2.

In this study, we first observed the IR spectrum of the pure U(V) complex and revealed that the  $\nu_3$  peak of  $\text{U}^{\text{V}}\text{O}_2^+$  appears at a lower wavenumber than that of  $\text{U}^{\text{VI}}\text{O}_2^{2+}$ ; i.e., the  $\text{U}=\text{O}$  bond strength is weakened with the reduction from  $\text{U}^{\text{VI}}\text{O}_2^{2+}$  to  $\text{U}^{\text{V}}\text{O}_2^+$ .

IC0342402