

CONTRIBUTION FROM THE DEPARTMENT OF CHEMISTRY,
WASHINGTON UNIVERSITY, ST. LOUIS, MISSOURI**Kinetics of Electron Exchange between Hexacyanoferrate(II) and -(III) Ions^{1a}**By RAYMOND J. CAMPION,^{1b} CHARLES F. DECK, PERRY KING, JR.,^{1c} AND ARTHUR C. WAHL^{1d}

Received November 19, 1966

The rate of isotopic exchange between $\text{Fe}(\text{CN})_6^{4-}$ and $\text{Fe}(\text{CN})_6^{3-}$ has been measured in aqueous solutions containing a number of different electrolytes. The rate was found to be first order in the concentration of each reactant and to depend markedly on the nature and concentration of the cations present. Very little dependence was found on the anion concentration or on the ionic strength at constant cation concentration. The following values of the rate constant ($M^{-1} \text{sec}^{-1}$) at 0.1° and the activation energy (kcal/mole), respectively, were determined for alkaline solutions containing 0.01 M of the indicated cation: $(\text{CH}_3)_4\text{N}^+$, 1260 and 0.3; $(\text{C}_2\text{H}_5)_4\text{N}^+$, 250 and 0.6; $(n\text{-C}_3\text{H}_7)_4\text{N}^+$, 41 and 5.2; $(n\text{-C}_4\text{H}_9)_4\text{N}^+$, 23 and 5.0; $(n\text{-C}_5\text{H}_{11})_4\text{N}^+$, 16 and 7.8; $(\text{C}_6\text{H}_5)_4\text{As}^+$, 28 and 6.3; $\text{Co}(\text{C}_5\text{H}_5)_2^+$, 1050 and -1.0 ; K^+ , 230 and 6.0. The large and specific effects of different cations is attributed to the participation of cations in the reaction by reduction of the Coulombic repulsion between the reactants in an activated complex. There is no evidence, however, that the cations participate in the actual transfer of an electron. Extrapolation to zero cation concentration gave values of $6.0 M^{-1} \text{sec}^{-1}$ and 9.1 kcal/mole for the rate constant at 0.1° and the activation energy, respectively, for very dilute solutions. From these values the free energy and entropy of activation were calculated to be 15.6 kcal/mole and $-24 \text{ cal deg}^{-1} \text{ mole}^{-1}$, respectively. These values are compared with values calculated from a model based on the Marcus theory of electron transfer.

Introduction

The kinetics of isotopic exchange between the hexacyanoferrate(II) and -(III) ions is of considerable interest because exchange must occur by electron transfer, the complex ions being inert with respect to ligand exchange.² Franck-Condon restrictions on the rate of electron transfer should be minimal since the ions have similar structures;³ on the other hand, Coulombic effects on the rate should be prominent because of the large ionic charges. For these reasons, the experimental results are of interest in themselves and also for comparison with theoretical models of electron-transfer reactions.

The earliest investigations of the rate of isotopic exchange between ferro- and ferricyanide ions indicated that the rate was "unmeasurably large"; we found, however, that the rate though large was measurable.^{4,5} This article describes the results of our studies of the kinetics of the isotopic exchange reaction in aqueous solutions.

Most of the solutions studied were alkaline because early in the investigation it was found that hydrogen ion, even at small concentrations, catalyzes the exchange, and we were unable to keep the pH constant near neutrality without the use of buffers. Buffers were to be avoided because, as reported in this article, the rate is markedly dependent on the nature and con-

centration of the cations present, even those which are normally considered kinetically inert such as potassium ion and the tetraalkylammonium ions. Difficulty was experienced with the presence in reaction solutions of trace impurities which affected the exchange rate and made reproducible results difficult to achieve. In order to obtain reproducible results, small amounts of ethylenediaminetetraacetic acid were added to many reaction solutions; this addition resulted in slightly lower rates.

While this article was being prepared for publication, a study of the exchange reaction by a nuclear magnetic resonance method was reported.^{6,7} The nmr experiments were carried out at much higher electrolyte concentration than were the isotopic exchange experiments, so direct comparison of the results is not possible; however, within large uncertainties of long extrapolations the results appear to be consistent.

Experimental Section

Radioactivity.—The tracer used was either Fe^{55} or Fe^{59} . For radioactivity measurements, samples containing Fe^{55} were mounted as zinc ferricyanide for counting, and the intensity of the 5.9-kev X-rays emitted was measured with a side-window, flow-type, proportional counter. The counter window was made of Cellophane or Scotch Tape and was coated with a thin layer of graphite (Aquadag) to make it conducting. The counter was operated on a 90% argon-10% methane gas mixture (P-10 gas).

For radioactivity measurements of Fe^{59} , solutions were placed in test tubes, and the intensity of the γ rays emitted was measured with a well-type sodium iodide scintillation counter.

Relative specific activity values were calculated by dividing the measured counting rate for an aliquot of ferricyanide solution by the absorbance at 4200 Å determined for a 1-cm path length of solution.

Tagged ferrocyanide ion was prepared from iron(III) chloride containing Fe^{55} or Fe^{59} . First the iron(III) chloride was purified by two extractions from 6–8 M HCl into isopropyl ether. Then iron(III) hydroxide was precipitated from ammonia solu-

(1) (a) Supported by the National Science Foundation under Grants G-198, G-553, G-9493, G-24210, and GP-5939X and by the Washington University Computing Facilities through NSF Grant G-22296. Abstracted in part from the following Ph.D. theses: C. F. Deck (1956), P. King, Jr. (1960), and R. J. Campion (1963), Washington University, St. Louis, Mo. Presented in part at American Chemical Society National Meetings in St. Louis, Mo., March 1961 and in Atlantic City, N. J., Sept 1962. (b) David Sarnoff Fellow, 1959–1961. (c) Phillips Petroleum Fellow, 1957–1958; General Atomics Fellow, 1958–1959. (d) Author to whom inquiries should be addressed.

(2) A. G. MacDiarmid and N. F. Hall, *J. Am. Chem. Soc.*, **76**, 422 (1954).

(3) The Fe–C–N distances in $\text{Fe}(\text{CN})_6^{4-}$ and $\text{Fe}(\text{CN})_6^{3-}$ have not been measured accurately. However, the Fe–Fe (Fe–C–N–Fe) distances in Prussian blue, $\text{KFe}^{\text{III}}[\text{Fe}^{\text{II}}(\text{CN})_6]$, and Berlin green, $\text{Fe}^{\text{III}}[\text{Fe}^{\text{II}}(\text{CN})_6]$, have both been determined to be 5.1 Å [J. F. Keggin and F. D. Miles, *Nature*, **137**, 577 (1936)].

(4) A. C. Wahl and C. F. Deck, *J. Am. Chem. Soc.*, **76**, 4054 (1954).

(5) A. C. Wahl, *Z. Elektrochem.*, **64**, 90 (1960).

(6) A. Loewenstein, M. Shporer, and G. Navon, *J. Am. Chem. Soc.*, **85**, 2855 (1963).

(7) M. Shporer, G. Ron, A. Loewenstein, and G. Navon, *Inorg. Chem.*, **4**, 361 (1965).

tion, and the precipitate was suspended in a concentrated potassium cyanide solution. The suspension was heated in a steam bath for approximately 1 hr until the solution was clear and faintly yellow in color. Tagged potassium ferrocyanide was precipitated by addition of ethanol and purified by recrystallization from water-ethanol solution.

Tagged tetraphenylarsonium ferricyanide was prepared from aqueous solutions of $\text{Fe}^*(\text{CN})_6^{4-}$. A solution was treated with a solution of iodine in carbon tetrachloride, and $\text{Fe}^*(\text{CN})_6^{3-}$ was extracted into a chloroform solution of tetraphenylarsonium chloride. The solution was washed twice with water, and then diethyl ether was added to precipitate $[(\text{C}_6\text{H}_5)_4\text{As}]_3\text{Fe}^*(\text{CN})_6$. The compound was purified by repeated precipitation from chloroform and was then dissolved in water. The solution was filtered through a Millipore-VC filter and was allowed to evaporate to dryness in the air stream coming through the filter.

The radiochemical purity of each preparation of a tagged compound was checked by isotopic exchange between $\text{Fe}^*(\text{CN})_6^{4-}$ and $\text{Fe}(\text{CN})_6^{3-}$. After essentially complete exchange had occurred the specific activities of the two reactants were compared, or the specific activity of ferricyanide ion was compared with the average specific activity determined after oxidation of $\text{Fe}(\text{CN})_6^{4-}$ to $\text{Fe}(\text{CN})_6^{3-}$. For all preparations the specific activity values compared were the same within an experimental uncertainty of a few per cent.

Reagents.— $\text{K}_3\text{Fe}(\text{CN})_6$ and $\text{K}_4\text{Fe}(\text{CN})_6 \cdot 3\text{H}_2\text{O}$ were analytical grade reagents recrystallized twice from water. $[(\text{C}_6\text{H}_5)_4\text{As}]_3\text{Fe}(\text{CN})_6$ was prepared from $\text{K}_3\text{Fe}(\text{CN})_6$ and $[(\text{C}_6\text{H}_5)_4\text{As}]\text{Cl}$ by a procedure similar to the one described for the tagged compound. $\text{K}_3\text{Co}(\text{CN})_6$ was prepared by the method of Bigelow⁸ and recrystallized four times from water. $\text{K}_4\text{Ru}(\text{CN})_6$ was purchased from the K and K Laboratory or was prepared by the method of DeFord and Davidson.⁹ The prepared material was purified by recrystallization after treating a solution with iodine in carbon tetrachloride to oxidize $\text{Fe}(\text{CN})_6^{4-}$ impurity to $\text{Fe}(\text{CN})_6^{3-}$, which does not crystallize with $\text{K}_4\text{Ru}(\text{CN})_6 \cdot 3\text{H}_2\text{O}$.

Solutions of tetraalkylammonium hydroxides were prepared by mixing solutions of the recrystallized bromide salts (Eastman Organic Chemicals) with excess silver oxide (Mallinckrodt purified). After reaction was complete the basic solution was filtered, passed slowly through a Dowex 1-X4 anion-exchange column in the hydroxide form, and filtered through a Millipore-VC filter.

Solutions of $[(\text{C}_6\text{H}_5)_4\text{As}]\text{OH}$ were prepared by mixing solutions of $[(\text{C}_6\text{H}_5)_4\text{As}]\text{Cl}$ and KMnO_4 to precipitate $[(\text{C}_6\text{H}_5)_4\text{As}]\text{MnO}_4$, which was filtered, washed thoroughly with water, and treated with 30% hydrogen peroxide. After removal of manganese dioxide by centrifugation, the solution of $[(\text{C}_6\text{H}_5)_4\text{As}]\text{OH}$ was passed through either a Millipore-VC filter or a column of Amberlite IRA-400 (OH^-) resin.

A solution of $[\text{Co}(\text{C}_6\text{H}_5)_2]\text{OH}$ was prepared from a benzene solution of cobaltocene supplied by Araaphoe Chemicals, Inc. The cobaltocene was oxidized by aqueous hydrogen peroxide, and cobalticinium picrate was precipitated from the aqueous phase. The method of Wilkinson¹⁰ was used for purification and conversion to the chloride. A solution of the $[\text{Co}(\text{C}_6\text{H}_5)_2]\text{Cl}$ was treated with silver oxide, and the resulting solution was passed through a Dowex 1-X4 (OH^-) anion-exchange column and then through a Millipore-VC filter.

Solutions of potassium hydroxide were prepared in several ways. In the early work, before ethylenediaminetetraacetic acid was added to reaction solutions, Baker and Adamson "Special Low Carbonate" potassium hydroxide was used. Later, when ethylenediaminetetraacetic acid was added, no difference was observed in exchange rates determined using solutions prepared from Baker and Adamson "Reagent Special" potassium hydroxide and filtered through Millipore-VC filters and those

prepared from potassium bromide and silver oxide by the procedure described for the tetraalkylammonium hydroxide solutions.

Tetraphenylarsonium chloride was obtained from a variety of sources and was purified by recrystallization twice from sodium chloride solution and twice from water. Ethylenediaminetetraacetic acid was obtained from Versenes Inc. Water was redistilled from alkaline permanganate solution. All other reagents were of analytical grade.

Reactant Solutions.—For the early exchange experiments in potassium hydroxide solutions without added ethylenediaminetetraacetic acid, $\text{K}_4\text{Fe}^*(\text{CN})_6$ and $\text{K}_3\text{Fe}(\text{CN})_6$ were dissolved in appropriate solutions. For most other experiments, $[(\text{C}_6\text{H}_5)_4\text{As}]_3\text{Fe}(\text{CN})_6$ and $[(\text{C}_6\text{H}_5)_4\text{As}]_3\text{Fe}^*(\text{CN})_6$ were dissolved in separate basic solutions containing EDTA^{4-} ;¹¹ $\text{Fe}^*(\text{CN})_6^{3-}$ was then reduced by hydrogen at a platinum plate; and each solution was diluted to volume, filtered through Millipore-VC filters on stainless-steel funnels, and collected in quartz or polyethylene containers.

According to our interpretation of the data (see Discussion) the small concentrations of $(\text{C}_6\text{H}_5)_4\text{As}^+$ (usually 0.0006 M) introduced with reactant ions had little effect on the rate, increasing the rate constant by only $\sim 1 \text{ M}^{-1} \text{ sec}^{-1}$ at 0.1°. We checked this conclusion by removing $(\text{C}_6\text{H}_5)_4\text{As}^+$ from two sets of reactant solutions by passing them through an Amberlite IR 120 cation-exchange column in the hydrogen form and into basic solution, 0.01 M KOH or 0.003 M $[(n\text{-C}_4\text{H}_9)_4\text{N}]\text{OH}$. The measured rates agreed with those predicted.

Separation of Reactants.—The reactants were separated by extracting $\text{Fe}(\text{CN})_6^{3-}$ into a solution of tetraphenylarsonium chloride in chloroform¹² in the presence of $\text{Co}(\text{CN})_6^{3-}$ and $\text{Ru}(\text{CN})_6^{4-}$, ions which minimized the "zero-time" exchange.^{5,13} In most experiments 8 ml of aqueous reaction solution was mixed first with 2 ml of aqueous quench solution $6 \times 10^{-3} \text{ M}$ in $\text{K}_3\text{Co}(\text{CN})_6$ and $6 \times 10^{-3} \text{ M}$ in $\text{K}_4\text{Ru}(\text{CN})_6$, and then with 5 ml of chloroform solution 0.1 M in $[(\text{C}_6\text{H}_5)_4\text{As}]\text{Cl}$. Mixing was continued for 5 sec, and then the phases were separated by centrifugation for 30 sec. The $\text{Fe}(\text{CN})_6^{3-}$ was back extracted from the chloroform solution into an aqueous 0.75 M KNO_3 solution for specific-activity measurements. "Zero-time" exchange varied somewhat with the composition of the reaction solution but was reproducible for a given set of conditions.

Apparatus.—A diagram of the apparatus used for most experiments is shown in Figure 1; 4 ml of one reactant solution was placed in reservoir R-1 and 4 ml of the other was placed in reservoir R-2, 2 ml of aqueous quench solution was placed in vessel Q-1, and 5 ml of chloroform solution was placed in vessel Q-2. The reactant solutions were mixed by applying a pressure of 15 psi of nitrogen through tube S-1 to force the solutions together in stopcock M and through it into reaction vessel RV where the stirrer was rotating at $\sim 2000 \text{ rpm}$. The reaction was quenched by applying the pressure of nitrogen through tube S-2 forcing the aqueous quench solution and then the chloroform solution into the reaction mixture.

The application of pressure was controlled by solenoid valves. The time of exchange was taken to be the time interval between activation of the valves and was measured by an electric timer with a precision of $\pm 0.01 \text{ sec}$. Any difference between this time interval and the "true reaction time" was constant for a given set of conditions so affected only the intercept, not the slope, of an exchange curve.

The apparatus used in the early work differed from the one described by keeping the reaction solution under pressure in a reservoir between two stopcocks for the desired time interval and then delivering the reaction solution into a centrifuge tube containing the two-phase quenching mixture, which was being stirred. This apparatus worked well for experiments in which

(11) The symbol EDTA^{4-} is used for the ethylenediaminetetraacetate ion.

(12) L. Eimer and R. W. Dodson, Brookhaven National Laboratory Report No. BNL 93 (S-8), 1950, p 69 (unpublished).

(13) K. Wolfsberg, M.S. Thesis, Washington University, St. Louis, Mo. (unpublished).

(8) J. H. Bigelow, *Inorg. Syn.*, **2**, 225 (1946).

(9) D. D. DeFord and A. W. Davidson, *J. Am. Chem. Soc.*, **73**, 1469 (1951).

(10) G. Wilkinson, *ibid.*, **74**, 6148 (1952).

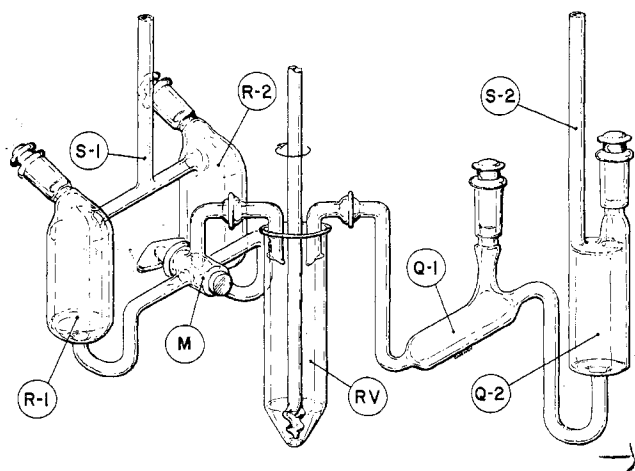

Figure 1.—Drawing of the apparatus used for measurement of exchange rates. The operation of the apparatus is described in the text.

reaction times were short; during long reaction times leaks sometimes occurred.

Interpretation of Data.—The fraction exchange was calculated by dividing the $\text{Fe}(\text{CN})_6^{3-}$ specific activity by its value after a long exchange time when isotopic equilibrium had been established or by the average specific activity of the reaction mixture determined after oxidation of $\text{Fe}(\text{CN})_6^{4-}$. The precision of the fraction-exchange determinations was estimated to be $\sim 2\%$.

The half-time for exchange, $t_{1/2}$, was taken from an exchange curve, a semilogarithmic plot of $1 - \text{fraction exchange}$ vs. the reaction time. A typical exchange curve is shown in Figure 2. The rate of exchange was calculated from the half-time through the familiar relationship¹⁴

$$\text{rate} = \frac{[A][B]}{([A] + [B])t_{1/2}} \quad (1)$$

in which [A] and [B] represent the concentrations of the reactants. When the rate follows the second-order law, $\text{rate} = k[A][B]$, as it does for the system being discussed (see next section)

$$k = \frac{1}{([A] + [B])t_{1/2}} \quad (2)$$

The uncertainty in measured values of k was estimated to be 5%. The uncertainty in concentration values was estimated to be $< 1\%$.

Results

Rate Dependence on Reactant Concentrations.

The results from experiments in which the concentrations of ferro- and ferricyanide ions were varied are shown in Figure 3. In all experiments one of the reactant concentrations was kept nearly constant at $\sim 1.0 \times 10^{-4} M$. The lines, which represent the data quite well, all have slopes of 1.00; thus the rate law

$$\text{rate} = k[\text{Fe}(\text{CN})_6^{4-}][\text{Fe}(\text{CN})_6^{3-}] \quad (3)$$

in which the concentrations are in units of gram-formula weights per liter, applies under a variety of conditions, and we assume that it applies under all conditions that we have studied. Of course the value of k depends on particular conditions, as is illustrated in Figure 3, and this effect is discussed in later sections.

(14) See, for example, O. E. Meyers and R. J. Prestwood, "Radioactivity Applied to Chemistry," A. C. Wahl and N. A. Bonner, Eds., John Wiley and Sons, Inc., New York, N. Y., p. 7.

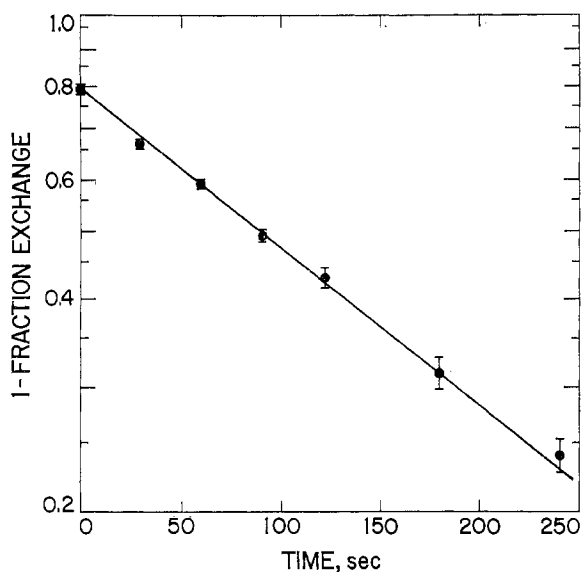

Figure 2.—Typical exchange curve. Conditions: 0.1° , $1.03 \times 10^{-4} M \text{Fe}(\text{CN})_6^{3-}$, $9.1 \times 10^{-5} M \text{Fe}(\text{CN})_6^{4-}$, $1.06 \times 10^{-2} M (\text{C}_6\text{H}_5)_4\text{As}^+$, $2.5 \times 10^{-4} M \text{EDTA}^{4-}$. Half-time: 128 sec. The errors shown correspond to ± 0.02 in the fraction exchange.

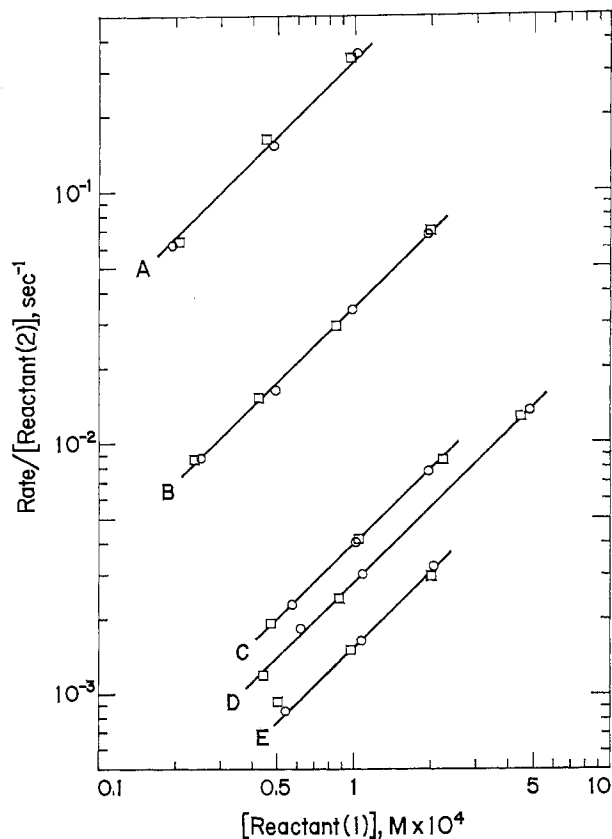

Figure 3.—Rate dependence on reactant concentrations. O: $\text{rate}/[\text{Fe}(\text{CN})_6^{3-}]$ vs. $[\text{Fe}(\text{CN})_6^{4-}]$, $[\text{Fe}(\text{CN})_6^{3-}] \approx 1.0 \times 10^{-4} M$; \square : $\text{rate}/[\text{Fe}(\text{CN})_6^{4-}]$ vs. $[\text{Fe}(\text{CN})_6^{3-}]$, $[\text{Fe}(\text{CN})_6^{4-}] \approx 1.0 \times 10^{-4} M$; Other conditions: 0.1° ; curve A— $0.0638 M \text{KOH}$; curve B— $0.0105 M \text{KOH}$, $2.0 \times 10^{-4} M \text{K}_4\text{Fe}(\text{CN})_6 + \text{K}_4\text{Ru}(\text{CN})_6$, $2.0 \times 10^{-4} M \text{K}_3\text{Fe}(\text{CN})_6 + \text{K}_3\text{Co}(\text{CN})_6$; curve C— $0.0100 M [(n\text{-C}_6\text{H}_7)_4\text{N}]\text{OH}$, $2.5 \times 10^{-4} M \text{EDTA}^{4-}$, $(5\text{--}10) \times 10^{-4} M (\text{C}_6\text{H}_5)_4\text{As}^+$; curve D— $0.0102 M (\text{C}_6\text{H}_5)_4\text{As}^+$, $2.5 \times 10^{-4} M \text{EDTA}^{4-}$, OH^- principal anion; curve E— $0.0100 M [(n\text{-C}_6\text{H}_{11})_4\text{N}]\text{OH}$, $2.5 \times 10^{-4} M \text{EDTA}^{4-}$, $(5\text{--}9) \times 10^{-4} M (\text{C}_6\text{H}_5)_4\text{As}^+$.

Some comments concerning the data shown in Figure 3 are pertinent. Concerning curve B, when $K_4Ru(CN)_6$ and $K_3Co(CN)_6$ were not added to keep the conditions of the electrolyte medium approximately constant, rate law (1) was not obeyed, the rate being larger than predicted at the lower reactant concentrations. This effect was probably caused by trace impurities, such as Ca^{2+} , which converted some fraction of the reactant ions to more reactive species (e.g., ion pairs). At low reactant concentrations this fraction would be larger than at high concentrations if the impurity were present in only trace amounts. Presumably, $Ru(CN)_6^{4-}$ and $Co(CN)_6^{3-}$ combined with the impurities to about the same extents as did the $Fe(CN)_6^{4-}$ and $Fe(CN)_6^{3-}$, so that at constant $Fe(CN)_6^{4-} + Ru(CN)_6^{4-}$ and $Fe(CN)_6^{3-} + Co(CN)_6^{3-}$ concentrations the fractions of reactant ions in their reactive forms were constants. It will be shown later in support of this postulate that Ca^{2+} and Ba^{2+} are effective catalysts even at very low concentrations and that addition of $EDTA^{4-}$ to a 0.01 M KOH reaction solution does decrease the rate of exchange.

Concerning curve D, the absence of $EDTA^{4-}$ caused the rate to be about 15% greater at all $Fe(CN)_6^{3-}$ concentrations and at the lower $Fe(CN)_6^{4-}$ concentrations; at the higher $Fe(CN)_6^{4-}$ concentrations the rate approached those determined with $EDTA^{4-}$ present. The effect is consistent with the presence of a trace impurity, such as Ca^{2+} , which associates extensively with $Fe(CN)_6^{4-}$, the associated species being more reactive than the free ion.

Concerning curve E, the point at the lowest $Fe(CN)_6^{3-}$ concentration lies above the line by a little more than the estimated experimental error. The value was reproduced in three experiments, and a somewhat larger value was obtained in a fourth. The cause of the discrepancy is not known. It may have been caused by trace impurities; it did occur under conditions for which the rate was small so that small effects due to impurities would be most noticeable.

Rate Dependence on $EDTA^{4-}$.—In our early work with potassium hydroxide solutions, reproducible kinetic data were obtained with a given set of reagents. Later, with other reagents, lower and varying values for the exchange rate were obtained. When $EDTA^{4-}$ was added still lower values were obtained and were reproducible. As shown in Table I, the exchange rate was not appreciably affected by variation of the $EDTA^{4-}$ concentration in the range $(1-10) \times 10^{-4} M$. The $EDTA^{4-}$ concentration employed for most reactant solutions was $2.5 \times 10^{-4} M$.

The $EDTA^{4-}$ anion forms very stable complexes with polyvalent cations, such as Ca^{2+} and Ba^{2+} , which are good catalysts. We believe the complex ions formed are probably inactive since they are negatively charged. The complexes formed between $EDTA^{4-}$ and singly-charged cations are much less stable, and at the concentrations employed only small fractions of the cations would be complexed.

Rate Dependence on Electrolyte Concentration.—As

TABLE I
DEPENDENCE OF THE RATE CONSTANT k ($M^{-1} \text{sec}^{-1}$) ON THE ELECTROLYTE AND ON THE CONCENTRATION OF $EDTA^{4-}$
(0.1°, 0.0100 M XOH, $1.0 \times 10^{-4} M$ $Fe(CN)_6^{4-}$, $1.0 \times 10^{-4} M$ $Fe(CN)_6^{3-}$, $6 \times 10^{-4} M$ $(C_6H_5)_4As^+$)

XOH	[$EDTA^{4-}$]				
	0 M	$1 \times 10^{-4} M$	$2.5 \times 10^{-4} M$	$5 \times 10^{-4} M$	$10 \times 10^{-4} M$
KOH	240-355	215	225	215	205
$[(C_6H_5)_4As]OH$	~37	...	28	29	...
$[Co(C_6H_5)_2]OH$	1050
$[(CH_3)_4N]OH$	1250	1280	...
$[(C_2H_5)_4N]OH$	250	245	...
$[(n-C_3H_7)_4N]OH$	41
$[(n-C_4H_9)_4N]OH$	23	21	...
$[(n-C_5H_{11})_4N]OH$	15

is shown in Table I and in Figure 3 the rate of exchange is very dependent on the nature of the electrolyte present at a concentration of 0.0100 M in the reaction solution. The dependence at other concentrations is shown in Figure 4. The large effect of electrolyte on exchange rate appears to be associated principally with the nature and concentrations of the cations, not of the anions, and not with the ionic strength, as is shown in Table II.

The results of some experiments on the effect of

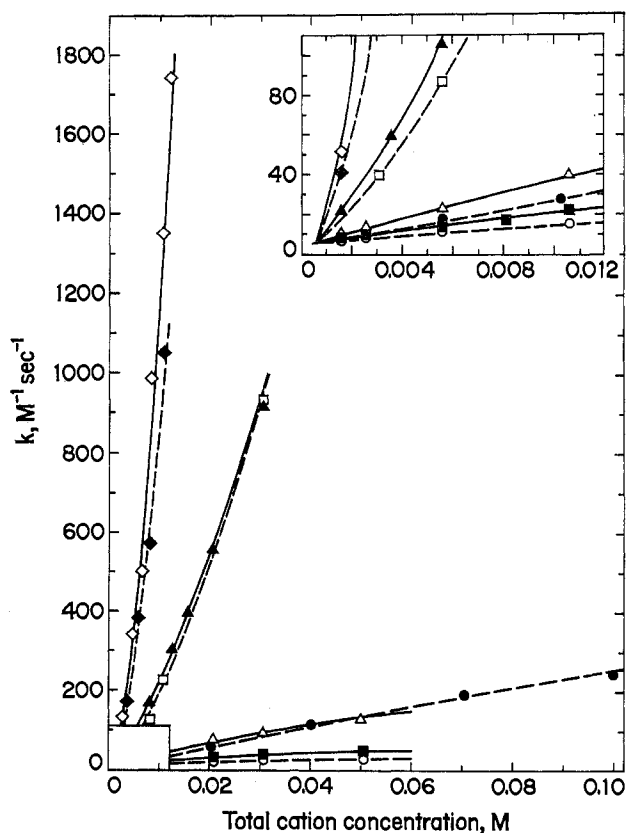

Figure 4.—Exchange rate dependence on cation concentration. The plot for the area in the lower left-hand corner is shown enlarged in the upper right-hand corner. Conditions: 0.1°, $6 \times 10^{-4} M$ $(C_6H_5)_4As^+$, $2.5 \times 10^{-4} M$ $EDTA^{4-}$, $1.0 \times 10^{-4} M$ $Fe(CN)_6^{4-}$, $1.0 \times 10^{-4} M$ $Fe(CN)_6^{3-}$, OH^- is other anion. \diamond , $(CH_3)_4N^+$; \blacklozenge , $(C_6H_5)_2Co^+$; \blacktriangle , $(C_2H_5)_4N^+$; \square , K^+ ; \triangle , $(n-C_3H_7)_4N^+$; \bullet , $(C_6H_5)_4As^+$; \blacksquare , $(n-C_4H_9)_4N^+$; \circ , $(n-C_5H_{11})_4N^+$. The lines represent eq 11 with the values of the parameters listed in Table V (entries 7-14).

TABLE II
RATE DEPENDENCE ON ANION CONCENTRATION AND IONIC STRENGTH
(0.1°, 1.0 × 10⁻⁴ M Fe(CN)₆⁴⁻, 1.0 × 10⁻⁴ M Fe(CN)₆³⁻, 2.5 × 10⁻⁴ M EDTA⁴⁻)

Cation	Anions	Ionic strength	<i>k</i> , M ⁻¹ sec ⁻¹
0.0100 M (<i>n</i> -C ₅ H ₁₁) ₄ N ⁺ ^a	0.0089 M OH ⁻	0.0130	17.7
0.0100 M (<i>n</i> -C ₅ H ₁₁) ₄ N ⁺ ^a	0.0039 M OH ⁻ , 0.0025 M SO ₄ ²⁻	0.0155	17.6
0.0100 M (<i>n</i> -C ₅ H ₁₁) ₄ N ⁺ ^a	0.0049 M OH ⁻ , 0.0006 M PO ₄ ³⁻ , 0.0011 M HPO ₄ ²⁻	0.0144	16.9
0.0200 M (C ₆ H ₅) ₄ As ⁺	0.0183 M OH ⁻	0.022	59
0.0200 M (C ₆ H ₅) ₄ As ⁺	0.0083 M OH ⁻ , 0.0100 M Cl ⁻	0.022	57
0.0200 M (C ₆ H ₅) ₄ As ⁺	0.0083 M OH ⁻ , 0.0020 M P ₃ O ₁₀ ⁵⁻	0.042	50
0.0400 M (C ₆ H ₅) ₄ As ⁺	0.0383 M OH ⁻	0.043	117
0.0400 M (C ₆ H ₅) ₄ As ⁺	0.0083 M OH ⁻ , 0.0150 M SO ₄ ²⁻	0.058	114
0.0400 M (C ₆ H ₅) ₄ As ⁺	0.0083 M OH ⁻ , 0.0060 M P ₃ O ₁₀ ⁵⁻	0.103	91

^a 6 × 10⁻⁴ M (C₆H₅)₄As⁺.

mixed electrolytes are shown in Table III. To a first approximation the effects of electrolytes on the rate are additive. However, there is some indication that the presence of (C₆H₅)₄As⁺ slightly enhances the catalytic effect of (CH₃)₄N⁺, whereas the presence of (*n*-C₅H₁₁)₄N⁺ decreases it.

TABLE III
RATE DEPENDENCE ON CONCENTRATIONS
OF MIXED ELECTROLYTES
(0.1°, 1.0 × 10⁻⁴ M Fe(CN)₆⁴⁻, 1.0 × 10⁻⁴ M Fe(CN)₆³⁻,
2.5 × 10⁻⁴ M EDTA⁴⁻, OH⁻ is the principal anion)

	Rate constants, M ⁻¹ sec ⁻¹		
	<i>k</i> _{ind} ^a	<i>k</i> _{sum} ^b	<i>k</i> _{exptl} ^c
0.0010 M (CH ₃) ₄ N ⁺	52	74	89
0.0100 M (C ₆ H ₅) ₄ As ⁺	28		
0.0020 M (CH ₃) ₄ N ⁺	133	155 ^d	160
0.0100 M (C ₆ H ₅) ₄ As ⁺	28		
0.0010 M (CH ₃) ₄ N ⁺	52	61	59
0.0100 M (<i>n</i> -C ₅ H ₁₁) ₄ N ⁺	15		
0.0015 M (CH ₃) ₄ N ⁺	90 ^e	99	80
0.0100 M (<i>n</i> -C ₅ H ₁₁) ₄ N ⁺	15		
0.0020 M (CH ₃) ₄ N ⁺	133	142 ^d	113
0.0100 M (<i>n</i> -C ₅ H ₁₁) ₄ N ⁺	15		
0.0010 M (CH ₃) ₄ N ⁺	52	68	68
0.0100 M (<i>n</i> -C ₄ H ₉) ₄ N ⁺	22		
0.0010 M (CH ₃) ₄ N ⁺	52	87	87
0.0100 M (<i>n</i> -C ₅ H ₇) ₄ N ⁺	41		
0.0100 M (C ₆ H ₅) ₄ As ⁺	28	36	36
0.0100 M (<i>n</i> -C ₅ H ₁₁) ₄ N ⁺	15		
0.0100 M (C ₆ H ₅) ₄ As ⁺	28	34	26
0.0050 M (<i>n</i> -C ₅ H ₁₁) ₄ N ⁺	12		

^a The value of the rate constant determined for the solution of the individual cation plus 6 × 10⁻⁴ M of (C₆H₅)₄As⁺. ^b The sum of the rate constants for solutions of individual cations minus 6 M⁻¹ sec⁻¹, the extrapolated value at 6 × 10⁻⁴ M (C₆H₅)₄As⁺ (see Figure 4). ^c The experimental value for a solution containing a mixture of the indicated cations plus 6 × 10⁻⁴ M of (C₆H₅)₄As⁺. ^d Solution 0.0020 M in Br⁻. ^e Interpolated value.

For the study of the effect of multicharged cations, EDTA⁴⁻ cannot be used to suppress the effect of impurities because extensive reaction occurs between EDTA⁴⁻ and the cations. Therefore, in order to obtain some knowledge of the effects of these cations, the following experiments were performed. Stock solutions of the reactants 0.0100 M in [(C₆H₅)₄As]OH were prepared,¹⁵ and the exchange rates were determined

(15) The reactant solutions for these experiments were prepared by passing solutions of K₃Fe(CN)₆ and K₄Fe*(CN)₆ through Dowex-50 (H⁺) resin columns into solutions of [(C₆H₅)₄As]OH.

with and without added CaCl₂, BaCl₂, or KCl. The differences in rates were attributed to the effects of the added cation and are shown in Figure 5.

A pair of experiments on the effect of hydrogen ion on the rate was performed as above except the reactant solutions 0.0100 M in [(C₆H₅)₄As]OH were neutralized either with boric acid to pH 8.8 or with acetic acid to pH 4.9. The measured exchange rates were 3.6 × 10⁻⁷ and 12.0 × 10⁻⁷ M⁻¹ sec⁻¹, respectively, for 1.0 × 10⁻⁴ M reactant concentrations, and the difference was attributed to the effect of H⁺. Ethylenediaminetetraacetate ion was present, but being in acidic forms probably had little effect on impurities. The rate constant determined at pH 8.8 agrees with those determined at pH 12.0 in the absence of EDTA⁴⁻ (see Table I).

Rate Dependence on Temperature.—The rate of exchange in various electrolyte solutions was measured as a function of temperature. The results for a number of solutions are plotted in Figure 6. The lines represent the equation

$$k = k_{0.1} \exp \left\{ \frac{E}{R} \left(\frac{1}{T_{0.1}} - \frac{1}{T} \right) \right\} \quad (4)$$

in which *R* is the gas constant, *k* is the rate constant at the absolute temperature *T*, and *k*_{0.1} is the rate constant at 0.1° (absolute temperature *T*_{0.1} = 273.3°K). The parameters *k*_{0.1} and *E* were adjusted by the method of least squares¹⁶ to give the best representation of the data. The derived values of *k*_{0.1} and *E* are listed in Table IV; the uncertainties shown are the standard deviations derived in the analysis.

Discussion

Electrolyte Effect.—The large and specific effects of cations on the rate of electron exchange between Fe(CN)₆⁴⁻ and Fe(CN)₆³⁻ strongly suggests that cations participate in the reaction. The participation may be through ion association with the reactants to give species, such as ion pairs, which undergo electron transfer more rapidly than do the unassociated reactant ions. The greater reactivity of ion pairs, etc., could be associated with the reduction by the cation(s) of

(16) The least-squares analysis was made with the computer program of L. A. Busing and H. A. Levy, Oak Ridge National Laboratory Report No. ORNL-TM-271, 1962 (unpublished). The program was modified for use with an IBM-7072 computer by R. A. Rouse and B. R. Erdal.

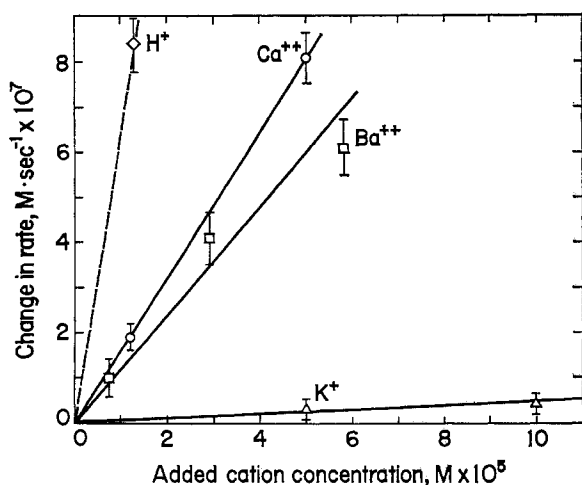

Figure 5.—Change in rate with addition of cations. Indicated uncertainties are calculated for 5% uncertainties in each of the two rates measured. Conditions: 0.1° , $0.0100 M (C_6H_5)_4As^+$, $1.0 \times 10^{-4} M Fe(CN)_6^{4-}$, $1.0 \times 10^{-4} M Fe(CN)_6^{3-}$.

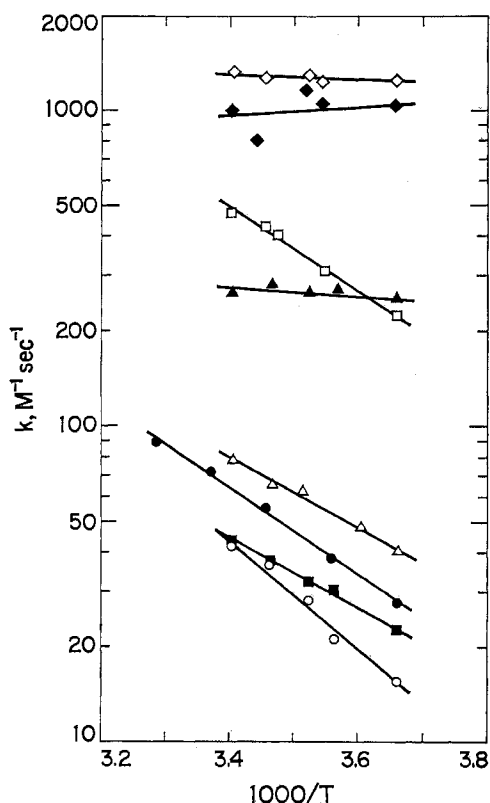

Figure 6.—Rate dependence on temperature. Conditions: $1.0 \times 10^{-4} M Fe(CN)_6^{4-}$, $1.0 \times 10^{-4} M Fe(CN)_6^{3-}$, $6 \times 10^{-4} M (C_6H_5)_4As^+$, $2.5 \times 10^{-4} M EDTA^{4-}$, $0.010 M$ base. \diamond , $[(CH_3)_4N]OH$; \blacklozenge , $[(C_6H_5)_2Co]OH$; \square , KOH ; \blacktriangle , $[(C_2H_5)_4N]OH$; Δ , $[(n-C_3H_7)_4N]OH$; \bullet , $[(C_6H_5)_4As]OH$; \blacksquare , $[(n-C_4H_9)_4N]OH$; \circ , $[(n-C_5H_{11})_4N]OH$. The lines represent eq 4 with the parameters listed in Table IV.

the Coulombic repulsion between the highly charged ferro- and ferricyanide ions in an activated complex. The proposed mechanism is illustrated by the series of reactions below. Rapid equilibria

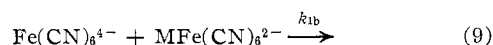
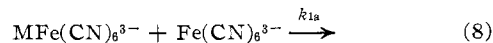
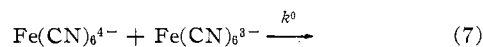

TABLE IV
RATE DEPENDENCE ON TEMPERATURE
($1.0 \times 10^{-4} M Fe(CN)_6^{4-}$, $1.0 \times 10^{-4} M Fe(CN)_6^{3-}$,
 $2.5 \times 10^{-4} M EDTA^{4-}$)

Solution	Temp range, $^\circ C$	$k_{0.1}$, $M^{-1} sec^{-1}$	E , kcal mole $^{-1}$
$0.0100 M [(CH_3)_4N]OH^a$	0.1–20.6	1260 ± 20	0.3 ± 0.2
$0.0100 M [(C_2H_5)_4N]OH^a$	0.1–20.6	250 ± 10	0.6 ± 0.3
$0.0100 M [(n-C_3H_7)_4N]OH^a$	0.0–20.6	40.6 ± 0.9	5.2 ± 0.4
$0.0100 M [(n-C_4H_9)_4N]OH^a$	–0.1–20.6	23.1 ± 0.3	5.0 ± 0.2
$0.0103 M [(n-C_5H_{11})_4N]OH^a$	–0.1–20.7	15.6 ± 0.4	7.8 ± 0.5
$0.0050 M [(n-C_5H_{11})_4N]OH^a$	0.1–20.7	11.9 ± 0.4	7.0 ± 0.4
$0.0030 M [(n-C_5H_{11})_4N]OH^{a,b}$	0.1–20.7	9.9 ± 0.3	7.6 ± 0.3
$0.0010 M [(n-C_5H_{11})_4N]OH^a$	0.1–20.7	7.9 ± 0.3	8.5 ± 0.5
$0.0406 M [(C_6H_5)_4As]OH$	0.1–30.8	111 ± 3	7.2 ± 0.3
$0.0200 M [(C_6H_5)_4As]OH$	0.1–31.0	61.6 ± 2.1	6.1 ± 0.3
$0.0103 M [(C_6H_5)_4As]OH$	0.1–31.1	28.2 ± 0.3	6.3 ± 0.2
$0.0056 M [(C_6H_5)_4As]OH$	0.1–30.8	18.6 ± 1.5	5.5 ± 0.7
$0.0100 M [Co(C_6H_5)_2]OH^a$	0.1–20.6	1050 ± 60	-1.0 ± 0.8
$0.0100 M KOH^a$	0.1–20.8	226 ± 3	6.0 ± 0.2
$0.0105 M KOH^c$	0.1–29.8	356 ± 2	4.6 ± 0.2

^a Solution $6 \times 10^{-4} M$ in $(C_6H_5)_4As^+$. ^b The value of k at 0.1° was not measured; a value of $10.0 \pm 0.5 M^{-1} sec^{-1}$ was calculated from eq 11 and the parameters listed in Table V, entry 7. ^c $2.0 \times 10^{-4} M Fe(CN)_6^{4-}$, $2.0 \times 10^{-4} M Fe(CN)_6^{3-}$, $EDTA^{4-}$ not present.

Rate-determining steps



Additional paths involving $M_2Fe(CN)_6^{2-}$ or $M_2Fe(CN)_6^-$ and an unassociated reactant ion could be involved and would be kinetically indistinguishable from the path represented by eq 10; for simplicity, however, we consider only this latter path.

There is considerable evidence for association of cations with ferro- and ferricyanide ions. Larsen and Wahl¹⁷ showed by nuclear magnetic resonance measurements that ferricyanide ion associates with tetramethyl-, -ethyl-, -*n*-propyl-, and -*n*-butylammonium ions. If only ion-pair formation were assumed, values of the equilibrium quotients K_b obtained were $\sim 10 M^{-1}$ for solutions 0.01 to 0.11 *M* in the ferricyanide salt at 25° .

Chlebek and Lister¹⁸ measured with a cation-sensitive glass electrode the extent of association of potassium ion with ferro- and ferricyanide ions. They found the equilibrium quotients K_a and K_b to be $31 M^{-1}$ and $7 M^{-1}$, respectively, at ionic strength 0.1 *M* and 24.65° ; values of $19 M^{-1}$ and $5 M^{-1}$ can be calculated for 0° from their data. Extrapolation to infinite dilution gave equilibrium-constant values of 170 and 25 at 24.65° .

Conductivity data and optical absorption measurements can also be interpreted in terms of ion-pair formation. The reported formation constants at 25° are about 20 and 700, respectively, for potassium and calcium or barium ion pairs with ferricyanide ion and about 200 and 6000, respectively, for the same cations

(17) D. W. Larsen and A. C. Wahl, *Inorg. Chem.*, **4**, 1281 (1965).

(18) R. W. Chlebek and M. W. Lister, *Can. J. Chem.*, **44**, 437 (1966).

TABLE V
 CATION CATALYSIS OF THE EXCHANGE REACTION PARAMETERS IN EQUATION 11^a

	Radius, Å ^b	$k_x, M^{-1} \text{sec}^{-1}$	$k', M^{-2} \text{sec}^{-1} \times 10^{-3}$	$k'', M^{-2} \text{sec}^{-1} \times 10^{-4}$	K', M^{-1}	K'', M^{-2}
(<i>n</i> -C ₅ H ₁₁) ₄ N ⁺	5.3	6.8 ± 0.3	1.41 ± 0.10	0	32 ± 4	0
(<i>n</i> -C ₅ H ₉) ₄ N ⁺	4.9	5.8 ± 0.4	2.20 ± 0.20	0	25 ± 5	0
(<i>n</i> -C ₆ H ₁₁) ₄ N ⁺	5.3	7.0 ± 0.3	1.07 ± 0.13	0	11 ± 7	220 ± 80
(<i>n</i> -C ₄ H ₉) ₄ N ⁺	4.9	6.1 ± 0.4	1.84 ± 0.25	0	9 ± 10	230 ± 130
(<i>n</i> -C ₅ H ₁₁) ₄ N ⁺	5.3	7.0 ± 0.2	1.20 ± 0.02	0	20	100
(<i>n</i> -C ₄ H ₉) ₄ N ⁺	4.9	5.9 ± 0.3	2.11 ± 0.05	0	20	100
(<i>n</i> -C ₅ H ₁₁) ₄ N ⁺	5.3	6	1.28 ± 0.04	0 ^c	20	100
(<i>n</i> -C ₄ H ₉) ₄ N ⁺	4.9	6	2.10 ± 0.04	0 ^c	20	100
(C ₆ H ₅) ₄ As ⁺ ^d	4.7	4.8 ± 0.3	2.06 ± 0.10	8.1 ± 0.4	20	100
(<i>n</i> -C ₃ H ₇) ₄ N ⁺	4.5	6	3.80 ± 0.22	4.2 ± 0.9	20	100
(C ₂ H ₅) ₄ N ⁺	4.0	6	15.8 ± 0.7	128 ± 8	20	100
Co(C ₅ H ₅) ₂ ⁺	3.6	6	28 ± 4	970 ± 70	20	100
(CH ₃) ₄ N ⁺	3.5	6	40 ± 4	1230 ± 90	20	100
K ⁺	1.3	6	11.0 ± 1.1	143 ± 12	20	100
(C ₆ H ₅) ₄ As ⁺ ^d	4.7	4.2 ± 0.5	2.45 ± 0.08	0	0	0

^a Reaction solutions: 0.1°, 1.0 × 10⁻⁴ M Fe(CN)₆⁴⁻, 1.0 × 10⁻⁴ M Fe(CN)₆³⁻, 2.5 × 10⁻⁴ M EDTA⁴⁻, 6 × 10⁻⁴ M (C₆H₅)₄As⁺, 1 × 10⁻³ to 5 × 10⁻³ M in designated cation. Values of kinetic parameters without errors were held constant while values with errors were determined by least-squares analysis of the data. ^b Radii were estimated by Robinson and Stokes' method [R. A. Robinson and R. H. Stokes, "Electrolytic Solutions," Academic Press Inc., New York, N. Y., 1955, pp 119, 120] from the molar volumes of compounds of similar structure, e.g., of Fe(C₅H₅)₂ for the Co(C₅H₅)₂⁺ radius, except the radius given for K⁺ is its crystal radius [*ibid.*, p 450]. ^c When k'' was allowed to vary, the values were negative or were within the standard error of zero. ^d A value of $k = 6.0 \pm 0.3 M^{-1} \text{sec}^{-1}$ was assumed for 6 × 10⁻⁴ M (C₆H₅)₄As⁺ solutions in the least-squares analysis.

paired with ferrocyanide ion.¹⁹ The theory of Fuoss²⁰ predicts constants of about 50 and 20 at 25° for the association of monovalent cations with ferro- and ferricyanide ions, respectively, when the distance of closest approach is 8 Å, a reasonable distance for the reactant ions (radii = 4.4 Å)²¹ and most of the cations investigated (see Table V).

None of the values for the association constants or quotients applies to the conditions of the isotopic-exchange experiments, and the corrections that would be required to make them applicable are uncertain and could be large. Therefore, we adopt a semiempirical approach in interpreting the effect of electrolytes on exchange rate.²²⁻²⁴

Olson and Simonson²⁵ proposed that the variation of the rate constant k with electrolyte concentration could be represented by an equation of the form

$$k = \frac{k_x + k'[M] + k''[M]^2}{1 + K'[M] + K''[M]^2} \quad (11)$$

in which [M] is the formal concentration of the cation, and k_x , k' , k'' , K' , and K'' are adjustable parameters. Equation 11 has the form to represent the reaction

paths that have been discussed, if the assumptions are made that a negligible fraction of a cation is associated with anions and that equilibrium quotients and rate constants do not vary with electrolyte concentration in the range investigated. For these assumptions and for a single cation, as existed in the tetraphenylarsonium hydroxide solutions, the relationship between the constants in eq 11 and those for reactions described in eq 5-10 is

$$k_x = k^0 \quad (12)$$

$$k' = k_{1a}K_a + k_{1b}K_b \quad (13)$$

$$k'' = k_2K_aK_b \quad (14)$$

$$K' = K_a + K_b \quad (15)$$

$$K'' = K_aK_b \quad (16)$$

For solutions containing two cations (M and M') one of which (M') is present at low concentrations and thus associates to a negligible extent with the reactants, the situation for many reaction solutions in which (C₆H₅)₄As⁺ was present at 6 × 10⁻⁴ M, eq 11 still applies, but

$$k_x = k^0 + k'_{M'}[M'] \quad (17)$$

Other terms involving functions of [M']² and [M']·[M] are assumed to be unimportant because of the small value of [M'] and because removal of the small amounts of (C₆H₅)₄As⁺ from several solutions affected the rate very little.

The kinetic data are not sufficient to evaluate all five parameters in eq 11, so the following procedure was adopted to obtain a good representation of the data with reasonable values of parameters.

(1) The constant k_x was taken to be the same at a given temperature for all reaction solutions, except for solutions containing tetraphenylarsonium ion as the only cation, and was evaluated from kinetic data for tetra-*n*-pentyl- and tetra-*n*-butylammonium hydroxide

(19) L. G. Sillén and A. E. Martell, "Stability Constants of Metal Complex Ions," The Chemical Society, London, 1964, pp 101-103.

(20) R. M. Fuoss, *J. Am. Chem. Soc.*, **80**, 5059 (1958).

(21) E. R. Nightingale, Jr., *J. Phys. Chem.*, **63**, 1381 (1959).

(22) We have also investigated the Brønsted-Bjerrum interpretation.²² Ion-pair formation constants were estimated from Bjerrum's theory,²⁴ activity coefficients were estimated from an extended form of the Debye-Hückel limiting laws, and rate constants were evaluated by adjusting values to give reasonable representations of the data. This treatment, presented at the 142nd National Meeting of the American Chemical Society, Atlantic City, N. J., Sept 1962, is more complex than the one presented in the text and is no more informative about the reaction mechanism. In addition it predicts an increase in rate with increasing ionic strength, a correlation that is not observed (see Table II).

(23) See, for example, S. W. Benson, "The Foundations of Chemical Kinetics," McGraw-Hill Book Co., Inc., New York, N. Y., 1960, p 525.

(24) N. Bjerrum, *Kgl. Danske Videnskab. Selskab*, **7**, No. 9 (1926); H. S. Harned and B. B. Owen, "The Physical Chemistry of Electrolytic Solutions," Reinhold Publishing Corp., New York, N. Y., 1958, p 70.

(25) A. R. Olson and T. R. Simonson, *J. Chem. Phys.*, **17**, 1167 (1949).

solutions by a least-squares procedure.¹⁶ Values of k_x and k' were calculated for various values of the other parameters, and as shown by the first six entries in Table V the value of k_x is not very dependent on the values of the other parameters used. A value of $k_x = 6 M^{-1} \text{ sec}^{-1}$ was chosen for subsequent calculations.

(2) The data were about equally well represented by eq 11 with values of K' and K'' of $30 M^{-1}$ and $0 M^{-2}$, respectively, or with values of $20 M^{-1}$ and $100 M^{-2}$, respectively, and other combinations undoubtedly could have been found.²⁶ However, in view of the relationships expressed in eq 15 and 16, the latter combination was chosen because the values are of a reasonable magnitude (e.g., if $K_a = 14 M^{-1}$ and $K_b = 7 M^{-1}$, $K' = K_a + K_b = 21 M^{-1}$ and $K'' = K_a K_b = 98 M^{-2}$).

The values of the parameters listed in Table V represent the data well, as shown by the lines in Figure 4, and thus are useful for interpolation and extrapolation of data. Also, the values may have some physical significance as discussed in the following paragraphs.

It is interesting that the values of k' and k'' vary inversely with the size of the cation, except for K^+ , as is shown in Table V. Since activity coefficient corrections should be of a similar magnitude for the various systems and since there is no evidence for appreciable change in K_b in the tetraalkylammonium ion series¹⁷ and, therefore, presumably not in K_a either,²⁰ most of the change in k' and k'' must be due to changes in rate constants (k_{1a} , k_{1b} , and k_2 in eq 13 and 14). The inference that the smaller the cation the more effective it is as a catalyst is a reasonable one, since the small cations would be most effective in reducing the Coulombic repulsion between the reactants. The deviation of the effect of K^+ from the general trend may be due to involvement of the hydrated ion rather than the unhydrated ion, although the estimate²¹ of 3.3 Å for the hydrated radius is not quite large enough to account for the effect of K^+ on the basis of size alone.

Very rough estimates of the rate constants k_{1a} and k_2 can be made by assuming $k_{1a} \approx k_{1b}$ and dividing k' by $20 M^{-1}$ and by dividing k'' by $100 M^{-2}$. The estimated values of k_{1a} increase from ~ 60 to $\sim 2000 M^{-1} \text{ sec}^{-1}$, and the values of k_2 increase from ~ 0 to $\sim 10^5 M^{-2} \text{ sec}^{-1}$ with decreasing cation size. The large range of k_2 values may indicate that an activated complex can contain more than one cation in effective positions only if the cations are relatively small.

For reaction solutions containing H^+ , Ca^{2+} , or Ba^{2+} values of k_{1a} can be estimated to be $\sim 1000 M^{-1} \text{ sec}^{-1}$ if it is assumed that the path described in eq 8 accounts for the catalytic effects of H^+ at low concentration and that analogous paths account for the effects of Ca^{2+} and Ba^{2+} . The values of the association quotients used are $7 \times 10^3 M^{-1}$ for $HFe(CN)_6^{3-}$ (the measured value at ionic strength 0.01²⁷) and $1.3 \times 10^3 M^{-1}$ for $BaFe(CN)_6^{2-}$ and $CaFe(CN)_6^{2-}$ (the measured value for $BaFe(CN)_6^{2-}$ at ionic strengths $(0.1-1.5) \times$

10^{-2} ²⁸). It appears, therefore, that the effectiveness of H^+ , Ca^{2+} , and Ba^{2+} as catalysts is due to the large constants for association of these ions with $Fe(CN)_6^{4-}$ and not to unusual reactivity of the ion pairs with $Fe(CN)_6^{3-}$.

The nmr investigation by Shporer, Ron, Loewenstein, and Navon⁷ of the exchange reaction at high concentrations of $K_4Fe(CN)_6$ and $K_3Fe(CN)_6$ ($1.4-2.8 M K^+$) gave rate constants in the range $(7-16) \times 10^4 M^{-1} \text{ sec}^{-1}$ at 32° . Calculations with eq 4 and 11 and the parameters for K^+ in Tables IV and V give estimated values of k in the range $(4-11) \times 10^4 M^{-1} \text{ sec}^{-1}$ for the above conditions. The agreement is probably fortuitous because in extrapolating over two orders of magnitude of concentration, changes in activity-coefficient corrections and possibly also in reaction paths are to be expected. The calculations do indicate, however, that a large fraction of each reactant is paired with K^+ and that the path represented by eq 10 is the only one of importance at the high K^+ concentrations. Under these conditions eq 11 reduces to $k \approx k_2$, indicating that the nmr determined rate constants may be a measure of k_2 . The value of k_2 for K^+ at low concentration and 0.1° estimated from the radiochemical data is $\sim 1.4 \times 10^4 M^{-1} \text{ sec}^{-1}$; this value may be compared with the value of $3.5 \times 10^4 M^{-1} \text{ sec}^{-1}$ from the nmr measurements at $\sim 1.75 M K^+$ and corrected to 0.1° .

The activation energy for exchange of 4.2 kcal/mole determined by the nmr method for high K^+ concentrations is fairly close to the values determined for 0.01 $M K^+$ solutions, 6.0 kcal/mole (in the presence of $EDTA^{4-}$) and 4.6 kcal/mole (in the absence of $EDTA^{4-}$). However, for 0.01 $M K^+$ solutions, exchange occurs about equally through paths represented by eq 8 or 9 and 10, according to the proposed model, so the activation energies from the two methods are probably not for the same processes.

It is interesting that at high ($\sim 1 M$) concentration of H^+ and Ca^{2+} , the exchange rate constants from the nmr measurements⁷ at 32° are <4000 and $<6700 M^{-1} \text{ sec}^{-1}$, respectively. It thus appears that the catalytic effects of these ions level off or decrease at high concentrations, a deduction which suggests that the rate constants for paths involving several cations are not especially large (much smaller than those involving $(CH_3)_4N^+$, for example).

We looked for such leveling effects at 0.05, 0.10, and 0.35 $M [(CH_3)_4N]OH$, but found complete exchange in reaction times of 1.5 sec. Since extensive exchange could have occurred during the separation, no limit could be set on the rate constant.

There is no evidence that the cations participate in the actual transfer of an electron. The catalytic effects of both $(C_6H_5)_4As^+$ and $Co(C_5H_5)_2^+$ are appropriate for their sizes, although both ions have some aromatic character and might be thought to provide an easier path for electron transfer than would the tetraalkylammonium ions. It should be noted, however,

(26) The data for $(C_6H_5)_4As^+$ solutions were also well represented by setting both K' and K'' equal to zero (see last entry in Table V).

(27) J. Jordan and G. J. Ewing, *Inorg. Chem.*, **1**, 587 (1962).

(28) S. R. Cohen and R. A. Plane, *J. Phys. Chem.*, **61**, 1096 (1957).

that all cations investigated are very difficult to reduce and so present a high barrier to electron transfer, possibly so high that the path involving a bridged activated complex in which the electron passes through the cation may not compete effectively with other paths involving activated complexes in which a cation is off center and electron transfer from $\text{Fe}(\text{CN})_6^{4-}$ to $\text{Fe}(\text{CN})_6^{3-}$ occurs either directly or through some solvent.

With reference to Table II, the small decrease in k observed when hydroxide ion is replaced by polyvalent anions can be explained by ion pairing. The observed rate constants are appropriate for the lowered cation concentrations that would result from pairing of each phosphate or triphosphate ion with one cation.

With reference to Table III, the effect of mixtures of electrolytes on the exchange rate can also be understood qualitatively in terms of the model that has been proposed. For the solutions studied, only small fractions of the reactant ions are tied up as ion pairs so, if a second cation is added, its catalytic effect will be nearly independent of the concentration of the first cation, and, to a first approximation, the rate of exchange in the mixed electrolyte solution will be the sum of the rates for reaction solutions containing the individual cations. To a second approximation, however, reactants tied up with a poor catalyst (e.g., $(n\text{-C}_5\text{H}_{11})_4\text{N}^+$) are not available to combine with a good catalyst (e.g., $(\text{CH}_3)_4\text{N}^+$), and the rate will be somewhat less than the sum. The slightly larger rate of exchange in $(\text{C}_6\text{H}_5)_4\text{As}^+$ - $(\text{CH}_3)_4\text{N}^+$ mixtures than predicted by the sum rule could be due in part to very little association of $(\text{C}_6\text{H}_5)_4\text{As}^+$ with the reactants—note that the kinetic data for $[(\text{C}_6\text{H}_5)_4\text{As}]\text{OH}$ solutions can be represented by a linear function (last entry in Table V)—and/or in part to electron transfer between one reactant paired with $(\text{C}_6\text{H}_5)_4\text{As}^+$ and the other with $(\text{CH}_3)_4\text{N}^+$. Also, the small deviations from the sum rule could be caused by changes in rate constants and equilibrium quotients with changes in the electrolytic medium. Perhaps more significant than the small deviations from the sum rule is the fact that it applies even approximately, an indication that there is little change with changing media of the various activity-coefficient corrections for equilibrium and rate constants or that the net effect of such changes is small.

Rate at Zero Cation Concentration.—The rate constant k^0 for exchange in the absence of electrolytes at several temperatures was estimated by extrapolating data for reaction mixtures containing $(n\text{-C}_5\text{H}_{11})_4\text{N}^+$ and $(\text{C}_6\text{H}_5)_4\text{As}^+$ to zero cation concentration. Equation 11 was used with $K' = 20$ and $k'' = 100$.²⁹ The data for 0.001–0.01 M $(n\text{-C}_5\text{H}_{11})_4\text{N}^+$ solutions at 0.1, 10.8, and 20.7° were extrapolated to $[(n\text{-C}_5\text{H}_{11})_4\text{N}^+] = 0 M$, $[(\text{C}_6\text{H}_5)_4\text{As}^+] = 6 \times 10^{-4} M$, and the values of k_x obtained were used with k values for more concentrated $(\text{C}_6\text{H}_5)_4\text{As}^+$ solutions to extrapolate to $[(\text{C}_6\text{H}_5)_4\text{As}^+] = 0 M$.

(29) Linear extrapolation (eq 11 with k'' , K' , and $K'' = 0$) was also employed and gave results very similar to those described in the text. Extrapolation using the Brønsted-Bjerrum equation²⁸ gave somewhat lower values of k^0 , but the activation energy calculated was essentially the same as the values obtained by the other extrapolation methods.

$[\text{As}^+] = 0 M$. Figure 7 illustrates the procedure. The values of k at 0.1, 10.8, and 20.7° for 0.0056, 0.0103, 0.0200, and 0.0406 M $(\text{C}_6\text{H}_5)_4\text{As}^+$ solutions were calculated using eq 4 and the parameters in Table IV.

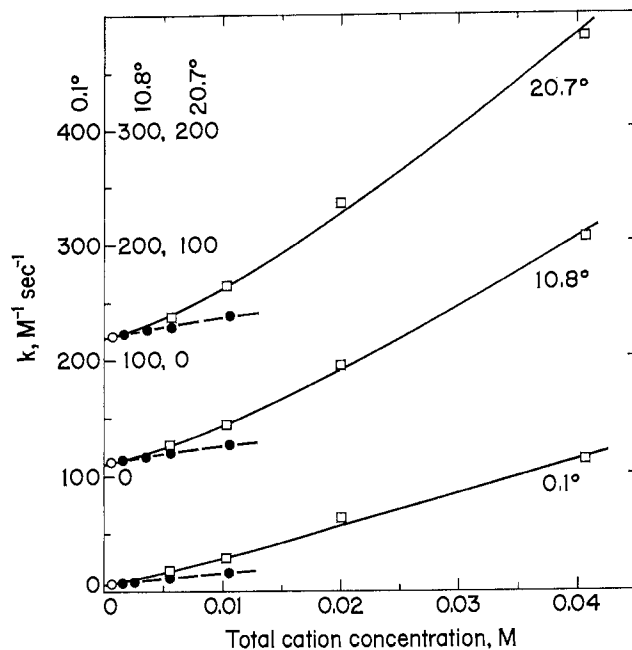

Figure 7.—Extrapolation to zero cation concentration. Conditions: $1 \times 10^{-4} M$ $\text{Fe}(\text{CN})_6^{4-}$, $1 \times 10^{-4} M$ $\text{Fe}(\text{CN})_6^{3-}$, $2.5 \times 10^{-4} M$ EDTA⁴⁻. ●, $[(n\text{-C}_5\text{H}_{11})_4\text{N}]\text{OH}$ solutions, $6 \times 10^{-4} M$ $(\text{C}_6\text{H}_5)_4\text{As}^+$; ○, $6 \times 10^{-4} M$ $(\text{C}_6\text{H}_5)_4\text{As}^+$ (value of k extrapolated from data for $[(n\text{-C}_5\text{H}_{11})_4\text{N}]\text{OH}$ solutions); □, $[(\text{C}_6\text{H}_5)_4\text{As}]\text{OH}$ solutions. Lines represent eq 11 with $K' = 20 M^{-1}$, $K'' = 100 M^{-2}$, and for the broken lines $k'' = 0 M^{-2} \text{sec}^{-1}$; other parameters were adjusted by the method of least squares.

The values of k^0 derived were 5.9, 11.3, and 19.2 $M^{-1} \text{sec}^{-1}$ at 0.1, 10.8, and 20.7°, respectively. The temperature dependence of the k^0 values is represented by eq 4 with values of $k_{0.1} = 6.0 M^{-1} \text{sec}^{-1}$ and $E = 9.1$ kcal/mole determined by the method of least squares.¹¹ From these values the Arrhenius constant A may be calculated to be $1.1 \times 10^8 M^{-1} \text{sec}^{-1}$, and the thermodynamic quantities associated with the absolute rate theory³⁰ may be calculated to be $\Delta S^\ddagger = -24$ cal/deg mole and $\Delta G^\ddagger = 15.6$ kcal/mole. Although the values are derived from extrapolated k^0 values, they are probably reasonably good since the k^0 values are not very dependent on the function used for extrapolation²⁹ and because the values are similar to those for the most dilute solution investigated, 0.001 M $[(n\text{-C}_5\text{H}_{11})_4\text{N}]\text{OH}$, for which catalytic effects are minimal.

It would be interesting to compare the experimental ΔG^\ddagger and ΔS^\ddagger values with experimental values for other similar reactions and with values predicted from theory. Unfortunately, only a few similar reactions have been investigated,^{31,32} and none has been investigated under conditions that allow extrapolation to zero electrolyte concentration.

(30) S. Glasstone, K. J. Laidler, and H. Eyring, "The Theory of Rate Processes," McGraw-Hill Book Co., Inc., New York, N. Y., 1941, pp 195, 199.

(31) N. Sutin, *Ann. Rev. Nucl. Sci.*, **12**, 285 (1962).

(32) J. Halpern, *Quart. Rev. (London)*, **15**, 207 (1961).

A great deal of work has been done on the theory of electron-transfer reactions, much of it by Marcus,³³⁻³⁶ who has also written a review of the subject.³⁷ In the Marcus formulation

$$k = \kappa \rho Z \exp(-\Delta G^*/RT) \quad (18)$$

The symbol κ represents the transmission coefficient, which is usually assumed to be ~ 1 *i.e.*, unit probability of electron transfer when other conditions are proper, an adiabatic reaction; ρ represents the square root of the ratio of the mean square deviation in reaction distance to the mean square deviation in perpendicular distance above the reaction hypersurface and is usually assumed to be ~ 1 ;³⁶ Z is the bimolecular collision number; and for exchange reactions ΔG^* is the sum of a work term, w , giving the energy required to bring the reactants together, and a reorganization term, $\lambda/4$, giving the energy required to adjust the coordination spheres of the reactants to equivalent energies before electron transfer, as required by the Franck-Condon principle. ΔG^* is related to ΔG^\ddagger by the equation

$$\Delta G^* = \Delta G^\ddagger + RT \ln(Z\hbar/kT) + RT \ln(\kappa\rho) \quad (19)$$

\hbar and k being the Planck and Boltzmann constants.

For evaluation of w and λ a model must be assumed. The only model for which detailed calculations have been made involves spherical reactants in a continuous and unsaturated dielectric medium.^{33,34} For these conditions ΔG^* is equal to the sum of the free energies of activation due to Coulombic repulsion (c) and reorganization of the outer (o) and inner (i) coordination spheres; thus ΔG^\ddagger may be calculated from

$$\begin{aligned} \Delta G^\ddagger &= \Delta G_o^\ddagger + \Delta G_i^\ddagger + \Delta G_c^\ddagger - RT \ln \kappa\rho - RT \ln(\hbar Z/kT) \\ &= 5.7 + 5.2 + 0 + 0 + 1.7 = 12.6 \text{ kcal/mole} \end{aligned} \quad (20)$$

The values of the terms were calculated from expressions given in the literature³¹⁻³⁷ on the assumptions that the reactants touch in an activated complex (8.8 Å between center), that $k\rho = 1$, and that $\Delta G_i^\ddagger = 0$. Similarly

$$\begin{aligned} \Delta S^\ddagger &= \Delta S_o^\ddagger + \Delta S_i^\ddagger + \Delta S_c^\ddagger + R \ln \kappa\rho + \\ &\quad R \ln(\hbar Z/kT) - R/2 \quad (21) \\ &= -26.4 + 0.6 + 0 + 0 - 5.7 - 1.0 = -32.5 \text{ cal/deg} \\ &\quad \text{mole} \end{aligned}$$

The difference of 3.0 kcal/mole between the experimental and theoretical values of ΔG^\ddagger corresponds to a factor of $\sim 10^2$ in k . There are a number of possible reasons for the discrepancy, including the approximate nature of the model itself. The reactants, though spherically symmetrical, are not spheres, and from an

examination of molecular models there appears to be space for water molecules between the cyanide ligands. In addition, the approximation of a continuous and unsaturated dielectric medium must break down near the reactant ions. Marcus has pointed out that dielectric saturation to some degree may exist near the highly charged reactant ions; this effect would increase ΔG_o^\ddagger , because the effective dielectric constant is lower than the bulk value, and would make ΔS_o^\ddagger less negative because the solvent medium is less reorientable.^{38a} In addition, a dielectric image contribution to ΔG_o^\ddagger of $\sim 8\%$ would further increase ΔG^\ddagger by ~ 0.5 kcal/mole.^{36,38a} These changes are in the direction to reduce the discrepancy between theory and experiment.

Marcus has also pointed out that electron transfer may occur at various distances when w is high and $\lambda/4$ is low and that ρ could exceed unity then,³⁸ thus making ΔS^\ddagger less negative and decreasing ΔG^\ddagger . Again, if the reaction distance were 9.8 Å, rather than 8.8 Å, ΔG^\ddagger would be further decreased by 1.3 kcal/mole and ΔS^\ddagger would be further increased by 3.1 cal/deg mole.³⁹ These changes would increase the discrepancy for ΔG^\ddagger and would decrease it for ΔS^\ddagger .

If the Fe-C bond distances in the reactants are assumed to differ by 0.05 Å, and if force constants for the bonds in both reactants are taken to be 2×10^5 dynes/cm,⁴⁰ ΔG_i^\ddagger would be ~ 1.0 kcal/mole, and ΔS_i^\ddagger would be ~ 0 . This change would reduce the discrepancy for ΔG^\ddagger .

If κ were 10^{-2} , ΔG^\ddagger would be increased by 2.7 kcal/mole and ΔS^\ddagger would be decreased by 9.2 cal/deg mole. This change would bring the theoretical and experimental ΔG^\ddagger values into agreement but would double the ΔS^\ddagger discrepancy.

The above discussion shows that there is considerable latitude for modifying the model within the basic theoretical framework³⁶ and indicates that both theoretical and experimental studies of dielectric saturation would be worthwhile undertakings. The experimental studies could be of other electron-transfer reactions between large ions with low charges, systems for which dielectric saturation would be minimal. The reactions should, of course, be studied in dilute solutions where reaction paths involving ion pairs are unimportant.

Acknowledgments.—It is a pleasure to thank Professor R. A. Marcus and Professor J. L. Kurz for helpful comments and discussions concerning the comparison between experiment and theory.

(38) (a) R. A. Marcus, private communication (1966). (b) For example, if ρ were ~ 20 , say, ΔS^\ddagger would be 6 cal/deg mole less negative and ΔG^\ddagger would be decreased by 1.8 kcal/mole.

(39) The distance at which reaction occurs is involved in the expressions for Z and for the Coulombic and outer-sphere reorganizational terms.

(40) V. Caglioti, G. Sartori, and C. Furlani, *J. Inorg. Nucl. Chem.*, **13**, 22 (1960).

(33) R. A. Marcus, *J. Chem. Phys.*, **24**, 966 (1956).

(34) R. A. Marcus, *ibid.*, **26**, 867 (1957).

(35) R. A. Marcus, *Discussions Faraday Soc.*, **29**, 21 (1960).

(36) R. A. Marcus, *J. Chem. Phys.*, **43**, 679 (1965).

(37) R. A. Marcus, *Ann. Rev. Phys. Chem.*, **15**, 1155 (1964).