

Some Complexes of Rhodium(III) Containing
Bromine and Water Ligands

W. Robb and P. van Z. Bekker

Received March 12, 1973

Introduction

The existence and behaviour of the various chloro- and chloroaquo- complexes of rhodium(III) in aqueous acid medium is reasonably well established. Apart from some equilibrium studies⁽¹⁾ coupled to ion exchange chromatographic separations of the various species and geometric isomers, some half dozen studies pertaining to the kinetics of interconversion have also appeared.⁽²⁻⁶⁾

This Laboratory reported the anation reactions of $\text{RhCl}_3(\text{H}_2\text{O})_2^{2-}$ with various nucleophiles in aqueous acid medium.^(4,5) A logical extension of these interests appeared to require a detailed study of the aquopentabromorhodate(III) analogue, a rather vaguely characterized species. We report here a study of the various species that apparently can exist in aqueous bromide medium involving chromatographic, analytical and spectrophotometric techniques as a prelude to a detailed kinetic study of the interconversion of the complexes.

Experimental Section

The starting material in the preparation was the K_3RhCl_6 complex. The latter was prepared from metallic rhodium, potassium chloride and chlorine gas by the method described in the literature.⁽⁷⁾

K_3RhBr_6 . Potassium hexabromorhodate(III) was prepared from K_3RhCl_6 as follows: The pH of an aqueous solution containing a known amount of K_3RhCl_6 was adjusted to a value of 9.0 by means of KOH. The resulting precipitate of $\text{Rh}(\text{OH})_3 \cdot 3\text{H}_2\text{O}$ was allowed to digest on a steam-bath for 5 hr by which time the supernatant was quite clear. The precipitate was removed by filtration and washed with water until no further signs of chloride ion were detected. An aqueous solution of hydrobromic acid and potassium bromide were added to the precipitate so that the stoichiometric amounts of 3:3:1 were

attained whereupon a clear solution was formed. After heating on a water-bath for a few min, 1l. of ice-cold ethanol was added to precipitate out the greenish coloured K_3RhBr_6 . The salt was then recrystallized from 4 M HBr solution by again adding ethanol and then dried at 140°C for 48 hr.

Analysis:	K	Rh	Br
Calc.	16.17	14.71	68.52
Found	16.75	14.80	67.92

The spectrum was measured in boiled out concentrated hydrobromic acid at 0°C on a Cary 15 Spectrophotometer and has the following characteristics

$$\lambda_{\max} \quad 555 \text{ nm} \quad \epsilon = 246 \text{ M}^{-1}\text{cm}^{-1}$$

$$\lambda_{\min} \quad 598 \text{ nm} \quad \epsilon = 205 \text{ M}^{-1}\text{cm}^{-1}$$

$\text{K}_2\text{RhBr}_5(\text{H}_2\text{O})$. A modification of Poulenc's⁽⁸⁾ method was used for this preparation. To a known amount of $\text{Rh}(\text{OH})_3(\text{H}_2\text{O})_3$ was added hydrobromic acid and potassium bromide in the molar ratios of 1:3:2. After heating, to effect dissolution of the rhodium hydroxide, the solution was allowed to concentrate in a desiccator containing silica gel. The first crop of crystals to appear was removed. The dark red octahedral shaped crystals were analysed and found to correspond to the formula $\text{K}_2\text{RhBr}_5(\text{H}_2\text{O})$. The spectrum taken in ice-cold water had.

$$\lambda_{\max} \text{ at } 542 \text{ nm with } \epsilon = 151 \text{ M}^{-1}\text{cm}^{-1}$$

$$\lambda_{\min} \text{ at } 488 \text{ nm with } \epsilon = 105 \text{ M}^{-1}\text{cm}^{-1}$$

$\text{K}_3\text{Rh}_2\text{Br}_9$. A compound corresponding to the above formula, *i.e.* a triple bromine bridged dimer, was prepared by boiling K_3RhCl_6 in 6 M hydrobromic acid until no further spectral changes occurred. Upon concentration of the solution blackish needle-like crystals were removed by filtration. A yield of 80%, based on the starting amount of chloro complex, was obtained.

Analysis:	K	Rh	Br
Calc.	11.25	19.74	69.00
Found	11.13	19.09	67.15

The UV visible spectrum has the following characteristics:

$$\lambda_{\max} \quad 563 \text{ nm} \quad \epsilon_{\max} \quad 475 \pm 10 \text{ M}^{-1}\text{cm}^{-1}$$

$$\lambda_{\min} \quad 520 \text{ nm} \quad \epsilon_{\min} \quad 369 \pm 10 \text{ M}^{-1}\text{cm}^{-1}$$

- (1) W.C. Wolsey, C.A. Reynolds, and J. Kleinberg, *Inorg. Chem.*, **2**, 466 (1963).
- (2) W. Robb and G.M. Harris, *J. Amer. Chem. Soc.*, **87**, 4472 (1965).
- (3) W. Robb, M.M. de V. Steyn, *Inorg. Chem.*, **6**, 616 (1967).
- (4) W. Robb, M.M. de V. Steyn, and H. Krüger, *Inorg. Chim. Acta*, **3** (3), 383 (1969).
- (5) W. Plumb and G.M. Harris, *Inorg. Chem.*, **3**, 542 (1964).
- (6) K. Swaminathan and G.M. Harris, *J. Amer. Chem. Soc.*, **88**, 4411 (1966).
- (7) G.H. Ayers and F. Young, *Anal. Chem.*, **24**, 165 (1952).
- (8) P. Poulenc, *Compt. rend.*, **190**, 641 (1930).

$K_4Rh_2Br_{10}$. The mother liquor from which $K_2RhBr_5 \cdot (H_2O)$ was obtained was allowed to concentrate further whereupon slender needle-like crystals separated out. This crop of crystals correspond to the above formula.

Analysis:	K	Rh	Br
Calc.	13.47	17.72	68.81
Found	14.02	17.88	68.79

The spectrum showed

$$\lambda_{\max} \text{ at } 555 \text{ nm with } \epsilon = 374 \text{ M}^{-1}\text{cm}^{-1}$$

$$\lambda_{\min} \text{ at } 517 \text{ nm with } \epsilon = 307 \text{ M}^{-1}\text{cm}^{-1}$$

$RhBr_4(H_2O)_2$ *fac*- and *mer*- $RhBr_3(H_2O)_3$. These species were not obtained in the solid form but were generated and characterized in the experiments described hereunder. 250 mg of K_3RhBr_6 in 5 ml of 10^{-3} M HClO_4 were heated on a steam-bath for 3 min, during which time hydrolysis occurs, before being cooled to 0°C . The solution was then introduced onto a 30 cm long by 1 cm diameter Dowex 1-X8 (200-400 mesh) anion exchange column which had been jacketted in ice.

Elution commenced using 10^{-3} M HClO_4 to remove any cationic species from the column. 0.1 M HClO_4 removed two bands containing the neutral *fac*- and *mer*- $RhBr_3(H_2O)_3$ species. The latter were identified from elemental analysis and their ligand field spectra were recorded. (See Table I). A solution of 0.4 M HClO_4 eluted a lilac-coloured band from an almost black rim at the top of the column. Eluted fractions were collected and combined as long as constant ligand field spectra were obtained. Analysis of the rhodium and bromine content gave a ratio of 1:4.03 and it was assumed that this was the $RhBr_4(H_2O)_2^-$ species. No isomers were found to be separated under these conditions. (See discussion). Sustained elution with this elutant eventually yielded fractions that were identical to the known $RhBr_5(H_2O)^{2-}$ variety in solution.

Table I. Ligand Field Spectral Data.

Complex	λ_{\max} nm	ϵ_{\max}	Ref.
$Rh_2Cl_6^{3-}$	435, 540	408.8, 98.0	^a
$Rh_2Br_6^{3-}$	563.0	475	^d
$Rh_2Br_{10}^{4-}$	555.0 (517.0) ^e	374 (307) ^e	^d
$RhBr_6^{3-}$	555.0 (498.0) ^e	246 (205) ^e	^d
$RhCl_6^{3-}$	411, 518	93.8, 111.5	^c
$RhCl_4(H_2O)_2^{2-}$	402, 507	99, 99	^d
$RhBr_5(H_2O)^{2-}$	542.0 (488.0) ^e	151 (105) ^e	^b

^a Work and Good⁽⁹⁾. ^b Wolsey, Reynolds, and Kleinberg⁽¹⁾. ^c W. Robb and G.M. Harris⁽²⁾. The ϵ values given in ref. (b) for $RhCl_4(H_2O)_2^{2-}$ were found to be slightly low. ^d This work. ^e These values pertain to λ_{\min} and corresponding ϵ_{\min} .

Analyses were performed by two different methods. a) The rhodium was determined as the metal after precipitation as the hydroxide and ignition under an hydrogen atmosphere. The bromide ions were deter-

mined by potentiometric titration using a P_{401} silver and K_{601} porous pin saturated $HgSO_4$ electrodes. (Radio-meter).

b) Addition of 10 ml of $HCl(c)$ to each of the fractions was followed by refluxing until the characteristic spectrum of the well-known $RhCl_6^{3-}$ species ($\lambda_{\max} = 411 \text{ nm } \epsilon = 94$; $\lambda_{\min} = 518 \text{ nm } \epsilon = 111.5$) was attained.

Discussion

The dimeric species, nonabromodirhodate(III) and decabromodirhodate(III), differ from the nonachlorodirhodate(III) in their readiness to crystallise out of aqueous acid medium as the potassium salts. Work and Good⁽⁹⁾ isolated the latter as the quaternary ammonium salt from acid medium. The relatively high molar absorptivity indices coupled with concomitant shifts to higher wave-lengths in the ligand field spectra served as the first indication that dimeric species had been precipitated from solution. This property of the complexes is analogous to that reported by Work and Good for the single chloro-complex where the changes in ϵ values are reported as shown in Table I.

A rather interesting complex was also isolated during the course of this study from the liquor that yielded $K_4Rh_2Br_{10}$ and $K_2RhBr_5(H_2O)$. It had the analytical composition $HK_3Rh_3Br_{18} \cdot 10H_2O$. The presence of a proton was detected by simple pH measurements of a millimolar aqueous solution of the complex. A three dimensional X-ray crystallographic structure⁽¹⁰⁾ determination showed that the $RhBr_6^{3-}$ octahedra were monomeric with two of them being non-equivalent in that the arrangement of the potassium ions were dissimilar. Thus, if one examines the conditions under which the species were prepared it would appear that the dissolution of $Rh(OH)_3 \cdot xH_2O$ in aqueous KBr and HBr in the molar ratio of 1:2:3 leads to the formation of $K_2RhBr_5(H_2O)$, $K_4Rh_2Br_{10}$

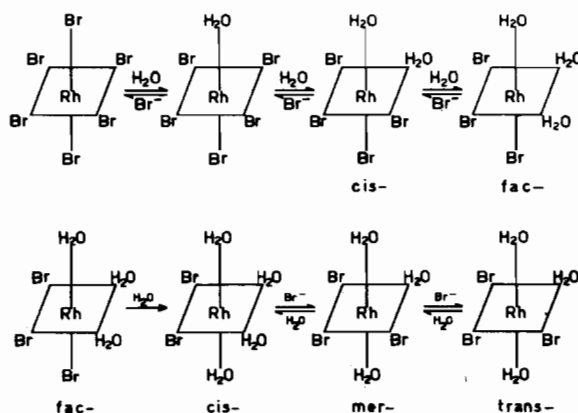

Figure 1. Expected products in hydrolysis of $RhBr_6^{3-}$ in aqueous acid medium, assuming *trans*-effect, $Br^- > H_2O$. The hydrolysis of *fac*- $RhBr_3(H_2O)_3$ leads to the following species.

(9) R.A. Work, III, and M.L. Good, *Inorg. Chem.*, 9 (4), 956 (1970).

(10) J. Coetzer, W. Robb, and P. van Z. Bekker, *Acta Cryst.*, 2 (10), 4 (1972).

and the RhBr_6^{3-} moiety all of which can exist in equilibrium with each other. The latter species is produced in only rather small amounts. Kinetic studies of the interconversion of these species have been completed and the rates indicate that the above situation of co-existence of species is to be expected.

The ion exchange experiments indicate that only a small percentage *ca.* 15%, of the RhBr_6^{3-} underwent hydrolysis during the time allowed. Nevertheless, it can be argued that the hydrolysis is fairly extensive for the $\text{RhBr}_5(\text{H}_2\text{O})^{2-}$, generated in the first place, since $\text{RhBr}_3(\text{H}_2\text{O})_3$ was identified in the experiment. The absence of isomers of $\text{RhBr}_4(\text{H}_2\text{O})_2^-$ is a little surprising because of the presence of *fac*- and *mer*- $\text{RhBr}_3(\text{H}_2\text{O})_3$. One can assume a *trans*-labilising effect of $\text{Br}^- > \text{H}_2\text{O}$ for the substitution reactions in such octahedral systems in order to rationalize our observations according to Fig. 1 below. The validity of this assumption can be based on several examples of *trans*-labilising reported in the literature^(11,12) and also found in work that is yet to be published.⁽¹³⁾

If only one isomer of $\text{RhBr}_3(\text{H}_2\text{O})_3$ was observed in the experiment one would have little hesitation in assigning a *cis*-configuration to the $\text{RhBr}_4(\text{H}_2\text{O})_2^{2-}$ species. However, since *fac*- and *mer*- $\text{RhBr}_3(\text{H}_2\text{O})_3$ were identified, the *cis*- and *trans*- $\text{RhBr}_4(\text{H}_2\text{O})_2^-$

must be presumed present with the *trans*-isomer derived from anation of *mer*- $\text{RhBr}_3(\text{H}_2\text{O})_3$ since the anation of *fac*- $\text{RhBr}_3(\text{H}_2\text{O})_3$ would yield *cis*- $\text{RhBr}_4(\text{H}_2\text{O})_2^-$ only.

The arguments of King⁽¹⁴⁾ and also Kleinberg⁽¹⁾ for the assignment of configurations in isomeric pairs eluted from ion exchange columns is used to assign the *mer*-configuration to $\text{RhBr}_3(\text{H}_2\text{O})_3$ first eluted the column. The second isomer to emerge was given the *fac*-configuration since it possesses a stronger dipole moment and is expected to have a greater retention time. The question of the origin of the *mer*- $\text{RhBr}_3(\text{H}_2\text{O})_3$ needs to be answered.

Ignoring the possibility of a *cis-trans* isomerisation in $\text{RhBr}_4(\text{H}_2\text{O})_2^-$ or *fac-mer* isomerisation in $\text{RhBr}_3(\text{H}_2\text{O})_3$ one must necessarily consider the further hydrolysis of *fac*- $\text{RhBr}_3(\text{H}_2\text{O})_3$ to produce *cis*- $\text{RhBr}_2(\text{H}_2\text{O})_4^+$ as shown in Fig. 1. The bromide anation of the latter complex provides the *mer*- $\text{RhBr}_3(\text{H}_2\text{O})_3$ species and hence the uncertainty in the nature of $\text{RhBr}_4(\text{H}_2\text{O})^-$ mentioned above. Since all rhodium(III) substitution reactions appear to be stereospecific in character the argument presented above seems to be the only alternative. Furthermore, the findings of Harris⁽¹⁵⁾ and the author in studies pertaining to the rhodiumchloroquo system are exactly parallel to observations reported here.

(11) H.L. Bott, E.J. Bounsall, and A.J. Poë, *J. Chem. Soc.*, (A), 1275 (1966).

(12) H.L. Bott and A.J. Poë, *J. Chem. Soc.*, (A), 205 (1967).

(13) M.J. Pavelich and G.M. Harris, Abstracts of National Meeting of Amer. Chem. Soc., New York, August, 1972.

(14) E.L. King, M.J.M. Woods, and H.S. Gates, *J. Amer. Chem. Soc.*, 80, 5015 (1958).

(15) Private Communication.