

# Interpretation of the $\nu(\text{CO})$ vibrational spectra of cluster compounds: $\text{Ru}_3(\text{CO})_9(\mu_3\text{-}\eta^2\text{:}\eta^2\text{:}\eta^2\text{-C}_6\text{H}_6)$

S.F.A. Kettle\*

*School of Chemical Sciences, University of East Anglia, Norwich NR4 7TJ (UK)*

R. Rossetti and P.L. Stanghellini\*

*Dipartimento di Chimica Inorganica, Chimica Fisica e Chimica dei Materiali, Università di Torino, via Pietro Giuria 7, 10125 Turin (Italy)*

B.F.G. Johnson

*Department of Chemistry, University of Edinburgh, West Main Road, Edinburgh EH9 3JJ (UK)*

(Received January 11, 1993)

## Abstract

The assignment of the infrared and Raman bands of the title compound in the  $\nu(\text{CO})$  region is made by qualitative observations on frequency and intensity data and confirmed by a normal coordinate calculation, which used the accurate force field available for the closely related  $\text{Ru}_3(\text{CO})_{12}$  molecule.

## Introduction

Although the study of the vibrational spectra of mononuclear transition metal carbonyls is no longer a particularly active research field, a continuing effort exists in the field of their polynuclear counterparts, although progress is slow. The reasons for this are not difficult to find. Most important is the fact that the normal coordinate analysis problems that arise are almost invariably seriously underdetermined. The use of data on isotopomers improves the situation and has been used by some workers. However, the method is only really valuable in high symmetry situations for there the number of isotopomers is relatively small. For low symmetry molecules a plethora of isotopomeric variants exists, each with its own characteristic spectrum, so that spectral interpretation becomes virtually impossible.

It is possible to set a different goal, that of simply attempting an unambiguous assignment of the spectral data. Such interpretations offer the prospect of qualitative insights into the details of the interactions between carbonyl groups on different metal atoms, information which could be of utility, for example, in understanding some of the data emerging from studies of adsorbed carbon monoxide. However, even this goal is difficult to attain, for the required spectral data

needed are seldom readily available. Most polynuclear complex carbonyls have only a limited solubility in common solvents making solution Raman data, in particular, rather difficult to obtain. Even solution IR poses problems for there is always the possibility that the species in solution may not be that in the solid state – impurities, decomposition and the adoption of a different geometrical arrangement of carbonyl groups are all possibilities.

Clearly, *inter alia*, there is a need to be able to use data from crystalline materials in such work. In the case of the Raman, the solid state spectrum may be needed to substitute for the solution. In the case of IR, it is necessary to check that none of the difficulties just listed are present. However, it is well known that both for mononuclear and polynuclear carbonyls the additional vibrational interactions that occur between molecules in the solid state may be such as to completely change the qualitative appearance of the spectrum.

Much of our recent work has therefore been aimed at the problem of whether it is possible to relate solution and solid state spectra in such situations. The general conclusion is that if the correct approach is adopted then the relationship may be made evident, so that in favourable cases it has proved possible to use solid state data as an aid in the assignment of molecular spectra and thus even facilitate a normal coordinate analysis [1].

\*Authors to whom correspondence should be addressed.

Indispensable in such work is a detailed knowledge of the crystal structure, for not only does a proper factor group analysis of the solid state spectra require this but also it helps recognition of spectral features that arise from crystal pseudo- or super-symmetry and from close contact between vibrationally coupled units in different molecules. Nonetheless, it has to be recognised that even with all this effort it is only in favourable cases that a spectral assignment can be realised with any reliability. If the situation is to improve it is necessary to invoke further information, although, clearly, it is scarcely likely that this will be information contained directly within the spectral data themselves. In the present communication we explore one such possibility, that of the transferability of data from one molecule to another quite different but related one.

### Experimental

$\text{Ru}_3(\text{CO})_9(\mu_3\text{-}\eta^2\text{:}\eta^2\text{:}\eta^2\text{-C}_6\text{H}_6)$  was prepared in moderate yield by a complex four step reaction detailed in ref. 2.

IR spectra were recorded for n-heptane solutions and KBr discs on a PE 580 IR spectrophotometer. Raman spectra were observed on microcrystalline samples with the Bruker FRA 106 FT-Raman module, attached to the IPS 66 FT-IR spectrometer (laser power 130 mW, resolution  $4\text{ cm}^{-1}$ ).

Normal coordinate calculations were performed using the program CLIMAX written by Dr G.J. Kearley (Institut Laue-Langevin, Grenoble).

### Results and discussion

The molecule  $\text{Ru}_3(\text{CO})_9(\text{C}_6\text{H}_6)$  may be regarded as a molecule of  $\text{Ru}_3(\text{CO})_{12}$  in which three axial CO groups have been replaced by a benzene molecule; the remaining CO groups are little changed [3, 4], (Fig. 1). A rather detailed normal coordinate analysis has been performed on  $\text{Ru}_3(\text{CO})_{12}$ , involving, incidentally, the use of solid state Raman data [5], an analysis which all subsequent work has supported [6]. This therefore seemed an ideal case for which to investigate parameter transferability. Only solid state Raman data are available but the observation of a fairly clear-cut relationship between solution and solid state IR, albeit with both intensity and frequency changes as well as band broadening, indicates that the diluent effect of the benzenes on the intermolecular carbonyl interactions may well serve to simplify this aspect of the problem. Equally, however, the observation that the highest frequency bands in the solid state IR and Raman are non-

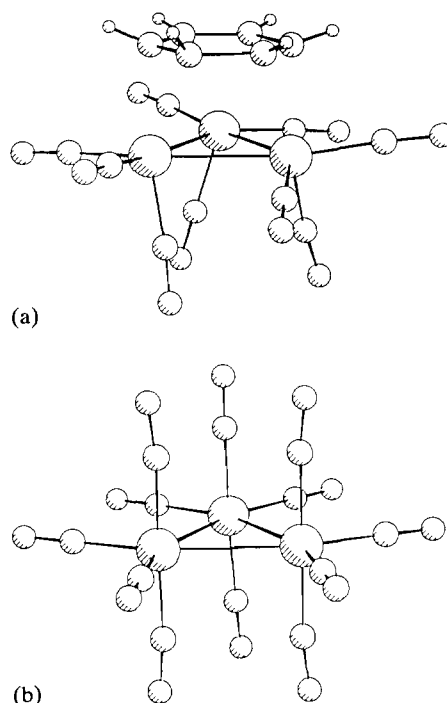

Fig. 1. Structure of (a)  $\text{Ru}_3(\text{CO})_9(\mu_3\text{-}\eta^2\text{:}\eta^2\text{:}\eta^2\text{-C}_6\text{H}_6)$  and (b)  $\text{Ru}_3(\text{CO})_{12}$

coincident is an unmistakable indicator that solid state effects cannot totally be ignored.

The molecular symmetry is ideally  $C_{3v}$ , although the crystallographic site symmetry is only  $C_1$ . The idealised symmetry of each  $\text{Ru}(\text{CO})_3$  group is also  $C_{3v}$ , but, as at the molecular level, the departure from ideality is not great – the C–M–C bond angles are all  $94 \pm 5^\circ$ . The compound crystallises in the space group  $P2_1$  with two molecules in the unit cell [4]. This means that, in principle, in the solid state each and every molecular feature is split into two and is allowed in both IR and Raman so that eighteen CO stretching bands might appear in both spectra. It is unlikely that this degree of complexity will be apparent and, indeed, it is not. Nevertheless it is possible to conduct the analysis at the molecular level, where just five bands, all coincident in IR and Raman, are predicted. In fact, four bands are seen in the solution IR spectrum.

The molecule-like behaviour finds a ready explanation in the details of the crystallographic structure. Because of the  $2_1$  axis the molecules are stacked herring-bone like, because they are tilted with respect to this axis, the inter-molecular CO contacts are not extensive, the contacts largely involving the benzene of one molecule against the carbonyls of its neighbours. While it is clear that this change of environment relative to solution causes changes in the  $\nu(\text{CO})$  band frequencies, the only other evidence of any solid state effect is in the small IR–Raman separations already mentioned, indicating that the residual intermolecular CO interactions, while

small are not entirely negligible. However, our discussion from this point on will either ignore or compensate for them, as appropriate.

In a qualitative analysis of the problem we start with the  $\text{Ru}(\text{CO})_3$  unit, of  $C_{3v}$  symmetry. This will give rise to  $A_1 + E$  features, the  $A_1$  at high frequency. Both modes will be active in both the IR and Raman, the E mode being of higher intensity in both spectra (the fact that the totally symmetric mode is not the most intense in the Raman stems from the fact that the C–O bond derived polarisability tensor is of opposite sign along and perpendicular to, the bond axis). This local  $A_1 + E$  splitting will be the greatest splitting in the spectrum.

In the molecule, the  $(\text{CO})_3$  groups of the  $\text{Ru}_3(\text{CO})_9$  couple together. The local  $A_1$  gives rise to molecular  $A_1 + E$ , distributing its IR and Raman intensity between them. Similarly, the local E gives rise to molecular  $A_1 + A_2 + 2E$ . Of these, the  $A_2$  is inactive in both IR and Raman. The likely general form of the splitting resulting is shown in Fig. 2.

The principle used in the construction of this diagram is that out-of-phase combinations will appear at lower frequency than their in-phase counterparts. Such an analysis does not uniquely determine which of the  $(A_1 + E)$  and  $(E + A_2)$  sets originating in the molecular E mode is at lower frequency. The pattern adopted in Fig. 2 was chosen because the solid state IR contains a broad low frequency band which is not immediately understandable in terms of the solution spectrum (Fig. 3). This suggests that there is a low frequency mode which is silent in the isolated molecule but which gains intensity in the solid state. In our initial work we considered the  $A_2$  an obvious candidate for this, although later it became clear that an E mode represented an even more likely explanation. However, by this stage we had become convinced that the splitting pattern

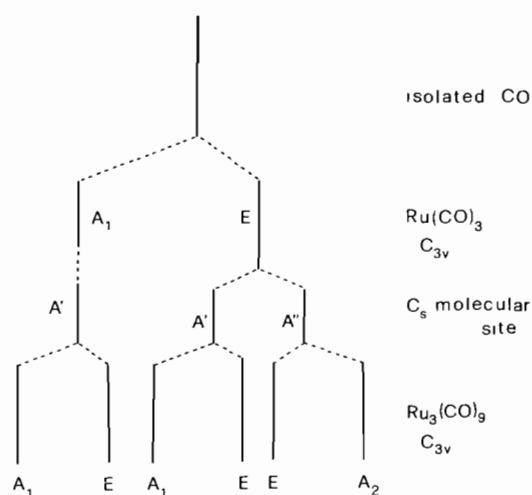

Fig. 2 The general pattern of the mode splitting.

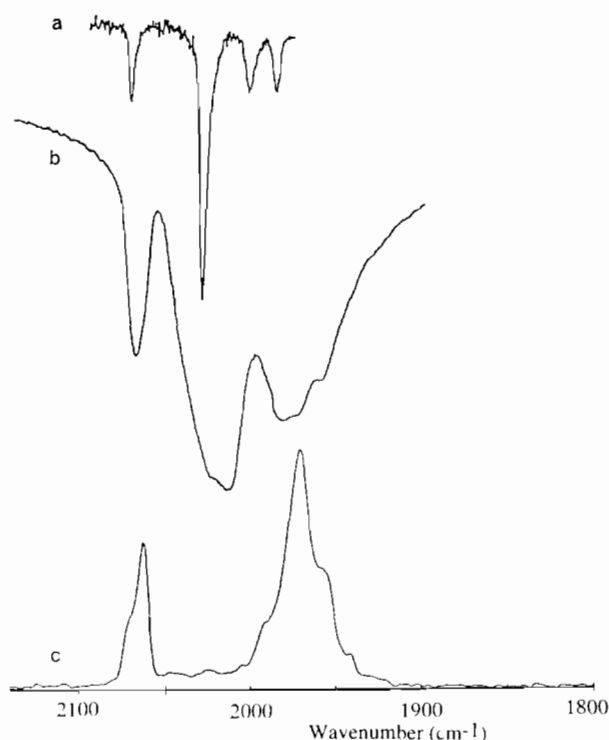

Fig. 3. Infrared (a: n-heptane solution, b: KBr disc) and Raman (c: crystals) spectra of  $\text{Ru}_3(\text{CO})_9(\mu_3\text{-}\eta^2\text{-}\eta^2\text{-}\eta^2\text{-C}_6\text{H}_6)$  in the  $\nu(\text{CO})$  region.

shown in Fig. 2 represents the true situation — we have found nothing that disagrees with it.

It is possible to compare these qualitative predictions with experiment in the case of the IR, for which solution data are available (Fig. 3). The solution IR shows a medium intensity peak at  $2075\text{ cm}^{-1}$  and a strong one at  $2032\text{ cm}^{-1}$ . Together, these might be taken as the  $A_1 + E$  pattern characteristic of an isolated  $\text{M}(\text{CO})_3$  group, were it not for two medium peaks at  $2005$  and  $1990\text{ cm}^{-1}$ . In the solid state spectrum this general pattern is retained, although intensity and frequency changes occur, one of which has been commented upon above. The frequency changes take the form of a drop which increases in magnitude as the band frequency itself decreases. In the solid state Raman, the highest frequency peak is some  $6\text{ cm}^{-1}$  below its IR counterpart, the latter appearing as a shoulder. Factor group splitting is clearly involved. The strongest, double-headed absorption, peaking between  $2010$  and  $2025\text{ cm}^{-1}$  in the solid state IR, finds no counterpart in the Raman, despite the fact that it has to be allowed. The IR intensity in the  $2032\text{ cm}^{-1}$  solution feature is clearly translated into the double-headed IR peak which must be a site-split molecular E mode; the IR peak must contain all the x, y activity and lack quadrupolar components. Conversely, the  $1972\text{ cm}^{-1}$  band in the Raman, the strongest in the spectrum, must contain all of these quadrupolar components and also be of E symmetry.

This peak occurs at approximately the same frequency as the displaced position of the (solution)  $1990\text{ cm}^{-1}$  band in the solid state IR ( $1974\text{ cm}^{-1}$ ). Just as the latter, very broad, peak shows three features, so, too does the Raman, two being shoulders. As far as can be judged, the IR and Raman frequencies coincide. The Raman peak shape give no hint that degeneracy is being relieved and so it seems most likely that the higher of the shoulders corresponds to the  $2005\text{ cm}^{-1}$  solution IR peak and thus be of  $A_1$  symmetry. We defer discussion of the other features in this region except to comment that the weak peak at  $1941\text{ cm}^{-1}$  in the Raman is most probably to be assigned to the  $A_2$  mode, silent at the molecular level. With inclusion of our low frequency assignments, these qualitative considerations lead us to assign the spectral data as indicated in Table 1.

Reasonable as the above arguments may be, some sort of independent check on the conclusions is desirable. Such an independent check is provided by the existence of a normal coordinate analysis of the  $\nu(\text{CO})$  modes in  $\text{Ru}_3(\text{CO})_{12}$  [5], a molecule which, as we have mentioned, is closely related to that presently under consideration. It is likely, therefore, that the force and interaction constants appropriate to  $\text{Ru}_3(\text{CO})_9(\text{C}_6\text{H}_6)$  will be similar to the corresponding ones of  $\text{Ru}_3(\text{CO})_{12}$ . These force and interaction constants are given and defined in Fig. 4 and were used to make predictions for  $\text{Ru}_3(\text{CO})_9(\text{C}_6\text{H}_6)$ . For the sake of consistency we have used constants defined to three decimal figures – this is how they are reported. However, as the following communication makes clear, there is no real justification for this level of precision. The resulting predicted values are given in the Table 1, which also lists the observed values.

Because the electron donating and withdrawing properties of a benzene molecule do not duplicate those of three CO groups, exact frequency agreement is not to be expected. Equally, the geometry of the  $\text{Ru}_3(\text{CO})_9$

TABLE 1. Observed and calculated  $\nu(\text{CO})$  values of  $\text{Ru}_3(\text{CO})_9(\mu_3\text{-}\eta^2\text{-}\eta^2\text{-C}_6\text{H}_6)$

Assignment	Calculated <sup>a</sup>		Observed			
	I	II	IR solution	IR solid	Raman	
$A_1$	2098	2075	2075		$\sim 2075$	
E	2046	2019	2033	$\sim 2024$	2063	
$A_1$	2036	2007	2005	1980	2005	
E	2015	1984			1982	1990
E	2010	1980			1974	1972
$A_2$	2000	1969		1960	$\sim 1960$	
					1941	

<sup>a</sup>See text for details

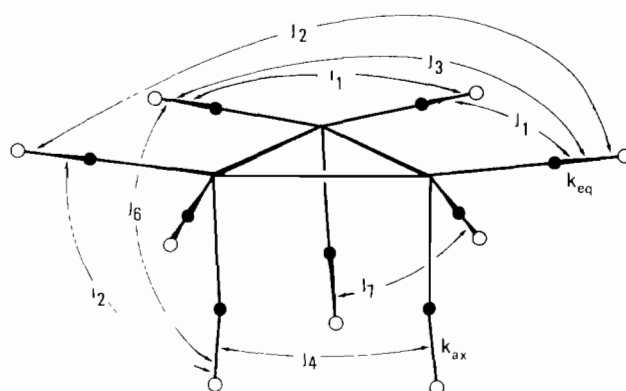

Fig. 4. Definition of the force and interaction constants

units in the two molecules differ, a feature which will also reduce precise agreement. To effect a comparison we have therefore linearly scaled the calculated so that they span the observed range. This scaling is sufficient to bring the calculated into approximate accord with the observed although this accord is not, of itself, totally compelling. Supporting evidence is needed. It is therefore gratifying to see that the symmetry species are in accord with our qualitative predictions (all of which were actually made before the normal coordinate calculation was carried out). Next, it is a simple matter to use the normal coordinate calculations to predict, qualitatively, the relative intensities of the IR active modes. Such predictions indicate that both  $A_1$  modes should be IR active, with the lower frequency perhaps the stronger. However, the central E mode is expected to be of very low intensity. An immediate explanation for the occurrence of four, and not five, bands in the solution IR is at once evident. Low IR activity is often associated with strong Raman and we are therefore inclined to assign the strong Raman band at  $1972\text{ cm}^{-1}$  to the solid state counterpart of this E mode. We note that the calculations place two E modes at  $c. 1990\text{ cm}^{-1}$ , of which we have just discussed one. That two modes of the same symmetry should be so close provides a qualitative explanation for the enhancement of IR intensity that occurs in their solid state counterparts. A considerable remixing of normal coordinates, and thus of intensities, passing into the solid state is entirely feasible. These changes could also indicate that the angular disposition of the carbonyl groups in the solid differs significantly from that in solution. Because the problem is grossly underdetermined, we have not attempted in any way to refine the normal coordinate calculation in order to obtain better agreement with experiment. Such an 'improvement' would be easy to obtain and quite meaningless in content.

## Conclusions

In the above analysis we used qualitative arguments to obtain, with some confidence, a spectral assignment of the  $\nu(\text{CO})$  spectra of a polynuclear metal carbonyl complex. Subsequently, a normal coordinate calculation in which the force constant data were taken from a related molecule and therefore fixed, confirmed these assignments. In retrospect, the sequence could have been reversed or the qualitative assignment stage omitted. The conclusions would have been the same. What this means is that if there exists a suitable model species for which an analysis of adequate quality has been performed, then it should be possible to make progress by first transferring force constant data and carrying out a normal coordinate calculation in order to assign the peaks observed. Provided that this procedure selects out from all of the possible interpretations one that is physically reasonable, then it seems probable that the correct assignment will have been made. It is only in especially favourable cases that the simple method adopted in this work will be possible. More commonly, the extrapolations needed will be longer. However, as we show in the following paper, even then it is possible to obtain results in which some considerable confidence may be placed. It therefore seems entirely likely that the present work points a way to the interpretation of

the vibrational spectra of low symmetry metal cluster carbonyls, an objective which has long seemed beyond reach.

## Acknowledgements

We thank Dr R. Margarit (Bruker Spectrospin Italiana, Milano) for the facilities provided to obtain the Raman spectra. Grants from CNR, Progetto Finalizzato (to R.R. and P.L.S.) are gratefully acknowledged.

## References

- 1 G. Gervasio, R. Rossetti, P.L. Stanghellini, D. Braga and S.F.A. Kettle, *J. Crystallogr. Spectrosc. Res.*, **23** (1993) 257.
- 2 B.F.G. Johnson, J. Lewis, M. Martinelli, A.H. Wright, D. Braga and F. Grepioni, *J. Chem. Soc., Chem. Commun.*, (1990) 364.
- 3 M.R. Churchill, F.J. Hollander and J.P. Hutchinson, *Inorg. Chem.*, **16** (1977) 2655.
- 4 D. Braga, F. Grepioni, B.F.G. Johnson, J. Lewis, C.E. Houscroft and M. Martinelli, *Organometallics*, **10** (1991) 1260.
- 5 G.A. Battiston, G. Bor, U.K. Dietler, S.F.A. Kettle, R. Rossetti, G. Sbrignadello and P.L. Stanghellini, *Inorg. Chem.*, **19** (1980) 1961.
- 6 (a) S. Kishner, P.J. Fitzpatrick, K.R. Plowman and I.S. Butler, *J. Mol. Struct.*, **74** (1981) 29; (b) T.R. Gilson, *J. Chem. Soc., Dalton Trans.*, (1984) 149.