

heats of combustion of the two fumaric acid samples differ appreciably. The reason for this is not obvious, however, the melting points and equivalent weight data in Table I indicate that sample A is more nearly pure than is sample B. It may be that sample B was not completely dry. The data for sample A was used in Table V.

The experimental heats of formation listed in Table V were calculated from the data in Table IV using the heats of formation of water and carbon dioxide given in the N.B.S. Circular 500 (13). The uncertainty intervals listed were based on the values of  $2\sigma$  in Table IV. Data from previous literature reported in Table V have been recalculated to correspond, as nearly as possible, to the units and conditions used in this report.

#### ACKNOWLEDGMENT

We wish to thank W.W. Wendlandt of Texas Technological College for the use of his thermobalance, DTA, and x-ray diffraction apparatus. Audrey Small, Carol Slaughter, W.H. Keresy, Wm. Phillips, S. Clinton, David Schooley, and C. McDaniel also assisted in various aspects of this work.

#### LITERATURE CITED

- (1) Beilstein's Handbuch der Organischen Chemie, Erstes Ergazungswerk, Band 2, Julius Springer, Berlin, 1929.
- (2) Bellamy, L.J., Pace, R.J., *Spectrochem. Acta* **19**, 435 (1963).
- (3) Broadly, J.S., Cruickshank, D.W.J., Morrison, J.D., Robertson, J.M., Shearer, H.M.M., *Proc. Roy. Soc. (London)* **A251**, 441 (1957).
- (4) Cox, E.G., Dougill, M.W., Jeffrey, G.A., *J. Chem. Soc.* **1952**, p. 4854.

- (5) Dupre La Tour, F., *Compt. rend.* **193**, 180 (1931).
- (6) Hubbard, W.M., Scott, D.W., Waddington, Guy, "Experimental Thermochemistry," Chap. 5, Interscience, New York, 1956.
- (7) Huffman, H.M., Fox, S.W., *J. Am. Chem. Soc.* **60**, 1400 (1938).
- (8) Landolt-Bornstein Tabellen, Vol. II, Part 8, 6th ed., Springer-Verlag, Berlin, 1961.
- (9) Lounguine, M.W., *Ann. Chim. Phys.* **23**, 179 (1891).
- (10) Pilcher, G., Sutton, L.E., *Phil Trans Roy. Soc. London* **A248**, 23 (1955).
- (11) Rieck, G.D., *Rec. trav. chim.* **63**, 170 (1944).
- (12) Rossini, F.D., "Experimental Thermochemistry," Chap. 14, Interscience, New York, 1956.
- (13) Rossini, F.D., Wagman, D.D., Evans, W.H., Levine, S., Jaffe, I., "Selected Values of Chemical Thermodynamic Properties," Natl. Bur. Stds. Circ. **500**, 1952.
- (14) Schwabe, K., Wagner, W., *Chem. Ber.* **91**, 686 (1958).
- (15) Smit, W.M., Kateman, G., "Purity Control by Thermal Analysis," p. 161, Elsevier, New York, 1957.
- (16) Stohmann, F., Kleber, Cl., Langbein, H., *J. Prakt. Chem.* **40**, 203 (1889).
- (17) Verkade, E., Hartman, H., Coops, J., *Rec. trav. chim.* [4] **45**, 373 (1926).

RECEIVED for review May 11, 1964. Accepted July 27, 1964. This research was supported by Grant GM-10868 of the National Institutes of Health. A portion of this paper is taken from the master's thesis of Daniel Shiao. Material supplementary to this article has been deposited as Document No. 8042 with the ADI Auxiliary Publications Project, Photoduplication Service, Library of Congress, Washington 25, D. C. A copy may be secured by citing the document number and by remitting \$1.25 for photoprints or \$1.25 for 35 mm. microfilm. Advance payment is required. Make checks or money orders payable to Chief, Photoduplication Service, Library of Congress.

## Mutual Solubilities in Water-Permethylosiloxane Systems

G. E. VOGEL and F. O. STARK

The Dow Corning Corp., Midland, Mich.

**The solubility of tritiated water in pure hexamethyldisiloxane, I; hexadecamethylheptasiloxane, II; and octamethylcyclotetrasiloxane, III, at 25.0°C. is less than one part per million. On a weight basis this value represents the lower limit of water detectable in these experiments. The solubility of carbon-14 labeled octamethylcyclotetrasiloxane, IV, in water at 25.0°C. was 2.0 parts per million by weight. This latter value suggests that hydrogen bonding forces between water and siloxanes are weaker than the hydrogen bonding forces for most oxygenated functions such as diethyl ether.**

**T**HE HYDROPHOBIC nature of the siloxane bond in organosiloxanes is no longer surprising to the organosilicon chemist. There is, however, a paucity of reliable quantitative data in the literature which demonstrates this fact. Our present paper briefly reports the findings from an investigation of mutual solubilities in water-permethylosiloxane systems.

#### EXPERIMENTAL

**Materials.** Hexamethyldisiloxane, I, hexadecamethylheptasiloxane, II, and octamethylcyclotetrasiloxane, III, were fractionally distilled and then stored for at least three days in contact with chromatographic grade alumina.

Purified water was prepared by redistilling distilled water from a solution of alkaline potassium permanganate, through a tin condenser, into polyethylene bottles.

Tritiated water was obtained from New England Nuclear Corp. at a specific activity of 100 mc. per gram and diluted with purified water to the convenient activity level of 8  $\mu$ c. per gram before use.

Carbon-14 labeled octamethylcyclotetrasiloxane, IV, specific activity for these experiments 15  $\mu$ c. per gram, b.p. 171°C., was synthesized via conventional reactions starting from carbon-14 labeled methyl iodide purchased from Tracerlab. Further purification just prior to use was attained by injecting 1 cc. of IV into the preparative attachment available for the F & M Model 500 GLC unit. The

column packing was 20% dimethylsilicone gum on chromasorb P. Material known to be pure IV was collected in a  $-78^{\circ}\text{C}$ . trap and used in solubility measurements.

**The Solubility of Water in Siloxanes.** Nitrogen gas was saturated at  $25.0^{\circ}\text{C}$ . with tritiated water vapor and passed through a sample of siloxane contained in 25-ml. flasks arranged in series (see Figure 1). The first flask with siloxane acted as a trap for bulk water carried as spray into the system. The samples for dissolved water analysis were taken from the second siloxane flask. The entire apparatus, including connecting lines, was immersed in a thermostated water bath at  $25.0^{\circ}\text{C}$ ., while a nitrogen flow was maintained for the indicated times, sweeping approximately one gram of water vapor through the sample in 24 hours. To obtain reproducible solubility values, it was necessary to use borosilicate glass apparatus which had been passivated by soaking in concentrated HCl for 24 hours, washed thoroughly with purified water and dried at  $150^{\circ}\text{C}$ .

**The Solubility of Octamethylcyclotetrasiloxane, IV, in Water.** To approximately 40 ml. of purified water in passivated borosilicate glass flasks was added 0.1 gram of IV. The flasks were sealed with serum bottle closures, shaken, and stored upside down immersed in a  $25.0^{\circ}\text{C}$ . thermostated water bath. Water samples could be withdrawn without disturbing the siloxane-water interface by inserting a hypodermic needle attached to a syringe through the closure in the bottom of the flask. After equilibrium solubility values were obtained, IV was extracted from the flask with  $\text{CS}_2$ . The infrared spectrum of this  $\text{CS}_2$  solution was identical to that of authentic octamethylcyclotetrasiloxane (6).

**Isotope Assay.** Actual solubilities were calculated from the isotopic concentration in weighed samples. Sample activities were determined in a Packard Tri-Carb liquid scintillation spectrometer. Water samples were assayed for carbon-14 activity (siloxane concentration) in a toluene-cellosolve-Liquifluor counting solution. Counting efficiency was approximately 50%. Siloxane samples were assayed for tritium activity (water concentration) in a toluene-dioxane-Liquifluor counting solution. Counting efficiency was approximately 20%. All samples were counted to a standard error of 3%.

## RESULTS AND DISCUSSION

The data in Table I show that the solubility of water in the permethylsiloxanes is less than  $10^{-6}$  grams per gram fluid, a value which was our lower limit of reliable detection. This is in contrast to reported (2) values in which a water content of 50 p.p.m. in permethylsiloxane fluids was observed. Parenthetically, it might be noted that initial attempts to measure water solubilities gave inconsistent values which could not be duplicated. It was not until the siloxanes were stored over alumina and the solubilities determined in passivated glassware that these difficulties were overcome. These difficulties were undoubtedly the result of undetectable silanol formation arising through base-catalyzed hydrolysis of the siloxane bond.

From an application of the McGowan equation (4) to

$$\text{Log } \frac{C_1}{C_2} = K_n P \quad (1)$$

siloxane-water systems, the observed equilibrium solubility value of  $2.1 \times 10^{-6}$  gram of IV per gram of water, Table II, is 500 times larger than predicted. For the calculation the value for  $K_n$  of 0.013, found by N.C. Deno (1) in hydrocarbon-water systems, was used and  $P$ , the value for the parachor of I, was 637 (3). This enhanced solubility suggests the possibility of hydrogen bonding in which an H-bond energy,  $E_H$ , can be calculated from the modified McGowan equation (1).

$$\text{Log } \frac{C_1}{C_2} = K_n P - E_a \quad (2)$$

The value of  $E_H$  is obtained by multiplying  $E_a$  by 2.3  $RT$ ; thus for IV,  $E_H$  is 0.82 kcal. per mole, or 0.2 kcal. per

mole of  $\begin{array}{c} \text{CH}_3 \\ | \\ \text{—Si—O—} \\ | \\ \text{CH}_3 \end{array}$ . These low energies contradict state-

Table I. Water Solubility in Permethylsiloxanes at  $25.0^{\circ}\text{C}$ .

Compound	Vapor Contact Time, Hrs.	Water Activity	Solubility Grams $\text{H}_2\text{O}$ /Gram Siloxane $\times 10^6$
I $\text{Me}_3\text{SiOSiMe}_3$	6	Undetectable	<1
	22	Undetectable	<1
II $\text{Me}_3\text{Si}(\text{OSiMe}_2)_5\text{OSiMe}_3$	6	Undetectable	<1
	24	Undetectable	<1
III $(\text{Me}_2\text{SiO})_4$	48	Undetectable	<1

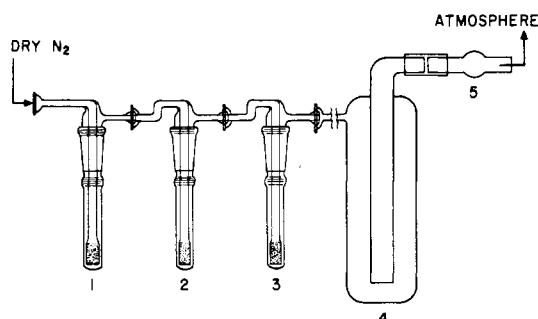

Figure 1. Apparatus for water solubility

Legend  
1 = tritiated water  
2 and 3 = siloxane  
4 =  $-76^{\circ}\text{C}$ . trap for water vapor  
5 = drying tube

Table II. Octamethylcyclotetrasiloxane, IV, Solubility in Water

Liquid Contact Time	Net $\text{C}^{14}$ Counts/Minute Per Gram Water	Solubility, (Grams Siloxane)/(Grams Water $\times 10^{-6}$ )
70 hrs.	130	7.8
118	58	3.5
168	49	2.9
240	36	2.2
408	30	1.8
600	34	2.0
912	35	2.1
1632 (68 days)	35	2.1

ments in the literature that water is strongly hydrogen-bonded to siloxanes, as for example, the explanation given for the strong adsorption of water on glass (7). Contrast this value of 0.2 kcal./mole for  $E_H$  in dimethylsiloxanes with the value of 2.26 kcal./mole observed for diethyl ether (1). This low value, however, observed for  $E_H$ -siloxane is in accordance with previous observations on the weak basicity of the siloxane bond in organosiloxanes (5).

#### ACKNOWLEDGMENT

The authors are indebted to O.K. Johansson and R.H. Baney for many discussions relating to this research.

#### LITERATURE CITED

- (1) Deno, N.C., Berkheimer, H.E., *J. Chem. Eng. Data* **5**, 1 (1960).
- (2) Ferrol, G., Saillard, A., *Bull. Soc. Chim., France* **1961**, p. 848.
- (3) Hunter, M.J., Hyde, J.F., Warrick, E.L., Fletcher, H.J., *J. Am. Chem. Soc.* **68**, 667 (1946).
- (4) McGowan, J.C., *J. Appl. Chem.* **4**, 41 (1954).
- (5) West, Robert, Whatley, L.S., Lake, K.J., *J. Am. Chem. Soc.* **83**, 761 (1961).
- (6) Wright, N., Hunter, M.J., *Ibid.*, **69**, 803 (1947).
- (7) Zisman, W.A., "Surface Chemistry of the Reinforcement of Plastics by Glass Fibers and Flakes," 19th Annual Symp., Society of Plastics Industry, Inc., Feb. 6, 1964.

RECEIVED for review May 4, 1964. Accepted July 20, 1964.

## Derivatives of *o*-Hydroxy- and *o*-Mercaptothioanisole

E. CAMPAIGNE and R. D. HAMILTON  
Indiana University, Bloomington, Ind.

SEVERAL NEW and readily accessible derivatives of *o*-hydroxy- (I) and *o*-mercaptothioanisole (II) have been prepared (Table I). Conversion of *o*-aminothioanisole into I (4) was achieved by diazotization followed by hydrolysis (5). Reaction of I with chloroacetyl chloride (2) afforded 2-(2'-chloroacetoxy)phenylmethyl sulfide (III) in good yield.

*o*-Mercaptothioanisole was prepared by the general procedure described by Livingstone (6) and by Gordella and Passerini (3), with one exception; the intermediate xanthate ester was reduced with lithium aluminum hydride (1) instead of hydrolyzed with potassium hydroxide. The method involving reduction gave yields of 30–31%, which

compares favorably with the 21% yield reported for potassium hydroxide hydrolysis (6). The disulfide of II (7) as well as some nitrophenyl derivatives (3) have been reported. Compounds IVa and IVb were prepared by allowing II to react with benzyl chloride and phenacyl chloride, respectively, in hot sodium ethoxide solution. Oxidation of IVa and IVb with 30% hydrogen peroxide in glacial acetic acid led to the disulfonyl compounds Va and Vb, respectively. When II was warmed to 80° with phenylisocyanate, phenylisothiocyanate or  $\alpha$ -naphthylisocyanate, and then cooled, the corresponding urethan derivatives IVc, IVd and IVf were obtained in good yields. The diphenylcarbamoyl ester (IVe) was also prepared.

Table I. Properties of Derivatives of *o*-Hydroxy- and *o*-Mercaptothioanisole

Compound	R	Name	Yield	M.P. <sup>a</sup>	Recryst. Solvent	Sulfur Anal.	
						Calcd.	Found
III		2-(2'-Chloroacetoxy)phenylmethyl sulfide	75	94–95	EtOH	14.8	14.7 <sup>b</sup>
IV	a	2-Benzylmercaptomethylmercaptobenzene	75	80–81	CH <sub>3</sub> OH	26.0	25.9
	b	$\omega$ -(2-Methylmercaptophenylmercapto)acetophenone	80	81	CH <sub>3</sub> OH	23.4	23.4
	c	S-(2-Methylmercaptophenyl)-N-phenylthiocarbamate	60	133.5–135	CHCl <sub>3</sub> -(hex.)	23.3	23.1
	d	2-Methylmercaptophenyl-N-phenyldithiocarbamate	64	109.5–111	Abs. alc.	33.0	33.3
	e	S-(2-Methylmercaptophenyl)-N, N-diphenylthiocarbamate	44	123–124	CHCl <sub>3</sub> -(hex.)	18.2	18.2
	f	S-(2-Methylmercaptophenyl)-N- $\alpha$ -naphthylthiocarbamate	60	169.5–171	CHCl <sub>3</sub> -(hex.)	19.7	19.5
V	a	2-Benzylsulfonylmethylsulfonylbenzene	65	169.5–171	EtOH-H <sub>2</sub> O	20.7	20.5
	b	$\omega$ -(2-Methylsulfonylphenylsulfonyl)acetophenone	59	143–144.5	CH <sub>3</sub> OH	19.6	18.9

<sup>a</sup> Melting points are corrected; <sup>b</sup> Anal. Calcd: C, 49.9; H, 4.2. Found: C, 50.2; H, 4.4.