

Density and Viscosity of Aqueous Hydrogen Sulfide Solutions at Pressures to 20 Atm

Joseph A. Murphy and George L. Gaines, Jr.¹

General Electric Corporate Research & Development, Schenectady, N.Y. 12301

The density and viscosity of water saturated with hydrogen sulfide at temperatures in the range 20–40°C and pressures up to 20 atm are measured. (A few measurements on water pressurized with nitrogen are also reported.) The density float method and a rolling-ball viscometer, modified to permit preequilibration of liquid with gas at pressure, are used. The results show that H₂S produces a maximum density decrement of 0.06%, relative to pure water at atmospheric pressure. The apparent molal volumes of H₂S in water estimated from the data are 35.1 ± 0.6 cm³/mol in this temperature and pressure range. These values are close to the molal volume of liquid H₂S at its normal boiling point (35.9 cm³/mol), suggesting that this gas, like nitrogen and the lowest hydrocarbons, is relatively "inert" in the sense of its effect on water structure. Near conditions for solid hydrate formation (28–30°C, 17–21 atm), the viscosity is 3–6% greater than that of pure water at the same temperature and atmospheric pressure. For practical purposes, therefore, the density and viscosity of water in the presence of pressurized H₂S over this range of conditions are not significantly affected by the gas.

The physical properties of aqueous hydrogen sulfide solutions under pressure are of practical importance in the large-scale concentration of deuterium by counter-current extraction of natural water with H₂S gas, the so-called GS process for heavy water production (7). In addition, information on these properties may be valuable in pollution abatement design. By virtue of the close chemical relationship between hydrogen sulfide and water, some scientific interest is also attached to the behavior of the solutions. Few studies of these properties, however, have been reported. In a previous paper from this laboratory (13), a substantial reduction of surface tension by hydrogen sulfide, as compared to water in the presence of air, was described. It has generally been assumed that the solution of H₂S in water at pressures up to a few tens of atmospheres has a negligible effect on the liquid density and viscosity, but we have been unable to find any experimental verification of this point. Only the density of water in the presence of H₂S at 1 atm appears to have been measured (6).

Experimental

All measurements were carried out in the same pressure vessel (a commercial liquid level gauge) with fittings and pressure gauge as used in our previous work (13), and the materials and procedures were the same as used in that study, except as noted below.

Density. A series of five ASTM density gradient floats, obtained from SGA Scientific, Inc., Bloomfield, N.J., was used to determine the density of distilled water equilibrated with H₂S. The densities of the floats used (reported by the supplier to be accurate to ±0.0002 g/cm³ at 23°C) were 0.9925, 0.9950, 0.9965, 0.9970, and 0.9980 g/cm³. Neutral buoyancy points were obtained for each float at

different pressures and temperatures by adjusting these two variables to establish conditions where the float neither rose nor sank in the liquid.

The same water thermostat previously used for surface tension measurements was employed for the density determinations. Preliminary tests showed that so long as the thermostat temperature was not changed at a rate greater than about 2°/hr, the temperature inside the pressure vessel matched the bath temperature within 0.1°C. Gas was introduced through a perforated tube inserted in the bottom of the vessel, and about 30 min of bubbling gas through the liquid was adequate to assure saturation (as judged by the constancy of subsequent density measurements). The equilibrium points were approached from both directions and were generally reproducible to within ±0.1°C, although in a few cases, discrepancies of 0.2°C were observed between repeat measurements. (Temperatures were estimated to ±0.03°C with a NBS calibrated thermometer in the thermostat; temperature differences produced during gas saturation may have contributed to the observed scatter of the results.) In any event, the limitation on our experimental precision would appear to be temperature control; an uncertainty of ±0.1°C corresponds to ±0.00002 g/cm³ in density.

Viscosity. A primary requirement for our apparatus was the ability to equilibrate the liquid with gas under pressure before carrying out the viscosity measurement. To this end, a modified rolling-ball viscometer (15) was designed (Figure 1). A precision alumina ball (Industrial Tectonics, Inc., Ball Division, Ann Arbor, Mich.) with a diameter of 0.9525 cm and a measured density of 3.827 g/cm³ (24°C), and a precision bore glass tube (Wilma Glass Co., Buena, N.J.), internal diameter 0.9710 cm, 27.9 cm long, with one end sealed, constituted the viscometer element. The tube was scribed with two marks 19.9 cm apart to permit visual measurement of ball roll times and the angle of inclination. The pressure vessel containing the viscometer was equipped with modified fittings to permit tilting (Figure 1). An air thermostat was used, although our experience suggests that a large liquid-filled bath would be more satisfactory.

To perform a measurement, the liquid was first equilibrated by bubbling the gas into the vessel held in a vertical position. During this operation, the ball remained at the bottom of the chamber, in the larger diameter perforated tube section, and the gas bubbles forced all of the liquid out of the central tube. After the desired period of equilibration, the gas flow was shut off, but the pressure vessel remained connected to the pressure gauge through the outlet connector. The apparatus was then tilted with the aid of a light chain and counterweight connected to its lower end. At an angle slightly above the horizontal, the liquid flowed through the holes in the perforated tube section and filled the viscometer tube. The total volume of liquid required to permit this procedure, 100 ml in our apparatus, had been established in preliminary tests, and this volume was charged in each series of measurements. A further elevation of the apparatus caused the ball to enter the working section of the tube, and the final angle of tilt was then established and the

¹ To whom correspondence should be addressed.

roll time observed. All of these manipulations could be performed easily and with good reproducibility with the aid of a pin inserted through selected links of the adjusting chain where it passed through the rigid cover of the thermostat. Roll times were measured with a hand-held stop watch for transits of the ball in both directions in the tube, with satisfactory agreement as discussed below.

According to Hubbard and Brown (15), streamline flow in a rolling-ball viscometer is obtained, providing that a critical Reynolds number is not exceeded. This critical Reynolds number, R_c , is a function of d/D , the ratio of ball diameter to tube diameter and is defined by Equation 1:

$$R_c = \frac{d^2}{D + d} \cdot \frac{\rho}{\mu} \cdot v_{\max} \quad (1)$$

where ρ and μ are the liquid density and viscosity, respectively, and v_{\max} is the maximum rolling velocity. For the dimensions of our apparatus, they obtained $R_c = 23$. Our experiments were performed at tilt angles such that the Reynolds number did not exceed 7.

Results and Discussion

Density measurements. The experimental results (neutral buoyancy conditions) are shown in Figure 2. To calculate liquid densities from these temperature and pressure values, it is necessary to take account of the thermal expansion and compressibility of the floats.

We have calibrated each float by determining the temperature at which it remained suspended in N_2 saturated water at 1 atm. At these temperatures, therefore, we take the float density to be that of pure water; the density values of Gildseth et al. (10) for air-free water have been used, since the solubility of nitrogen at 1 atm would alter these by less than 1 part in 10^6 . For the two lightest floats, the density of an isopropanol-water mixture which just suspended the float at 22°C was determined pycnometrically. These results coincided with the pure water calibrations when volumetric thermal expansion coefficients for the floats were taken to be $2.9 \pm 0.6 \times 10^{-5}$ /

°C. For the compressibility coefficient, we have used Bridgeman's data (2) for Pyrex glass. [It should be noted that even large (100%) errors in these coefficients would not affect the results by as much as our other experimental uncertainties, because the difference from the calibration conditions was always small.]

Using these values, we have calculated the density at each experimental point by dividing the calibration densities by $(1 - 3.1 \times 10^{-6} \Delta P + 2.9 \times 10^{-5} \Delta t)$, where ΔP (in atm) and Δt are the pressure and temperature difference between the experimental and calibration points.

Densities at uniform pressure intervals were calculated with temperatures read from the smooth curves in Figure 2. These values are listed in Table I. The densities observed for water under nitrogen are slightly higher than those of water at atmospheric pressure—the dissolved nitrogen does not offset the compressibility effect. On the other hand, H_2S produces a slight reduction in density, with the difference increasing at higher temperatures. The maximum density decrement observed, at 39.3°C and 18.3 atm, is 0.06% relative to pure water at 1 atm. This is considerably less than the possible change of 1.4% estimated by Galley et al. (8) on the basis of weight fraction additivity of liquid densities. The effect is thus clearly insignificant for practical purposes, and the density of these solutions may be taken to be equal to that of pure water at 1 atm and the appropriate temperature in engineering calculations. In particular, we note that no significant anomaly is observed in density measurements within 0.2° of the point of solid hydrate formation, and the same values were obtained after hydrate had been allowed to form and then melt.

Apparent molal volumes. Following Masterton et al. (21), we have calculated apparent molal volumes of H_2S in water by the relation:

$$\Phi_2 = \frac{M_2}{\rho} + \frac{X_1 M_1}{X_2} \left(\frac{1}{\rho} - \frac{1}{\rho^*} \right) \quad (2)$$

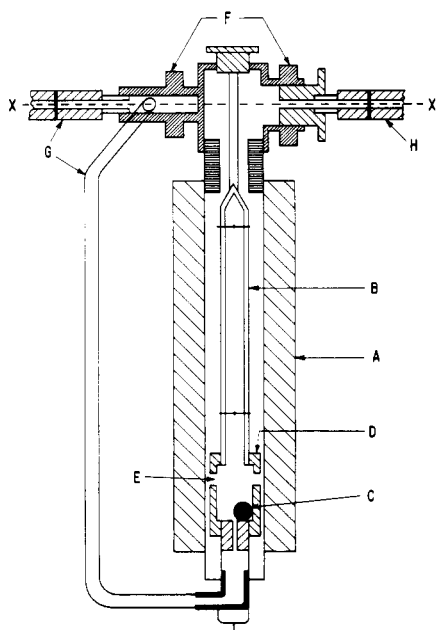

Figure 1. Rolling-ball viscometer

A, pressure vessel body; B, precision bore glass tube; C, precision alumina ball; D, perforated support tube; E, holes for gas flow; F, pivot bearings to permit tilting of tube around axis X-X; G, gas inlet; H, gas outlet (to pressure gauge). Rotation permitted at G and H by swivel disconnects to gas lines

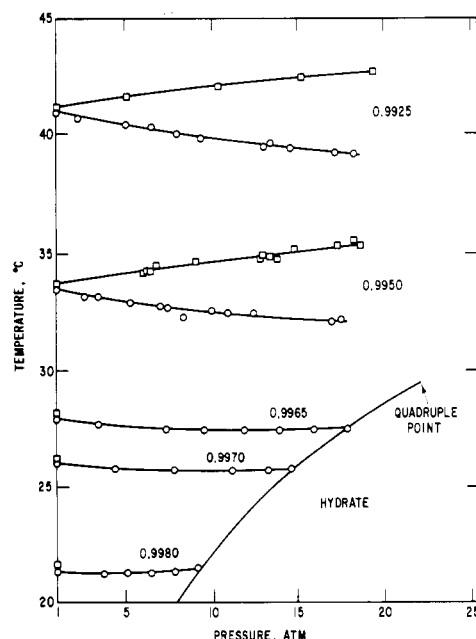

Figure 2. Temperatures of buoyancy equilibrium for five density floats in water equilibrated with nitrogen (\square) or hydrogen sulfide (\circ) at pressures up to 19.5 atm. Numbers on graph refer to nominal float densities. Line at lower right defines region of stability of solid hydrate of hydrogen sulfide

Table I. Density of Water Equilibrated with N₂ or H₂S
Pressure, atm

Solute	1.0		4.4		7.8		11.2		14.6		18.0	
	t, °C	ρ, g/cm ³	t	ρ	t	ρ	t	ρ	t	ρ	t	ρ
Nitrogen	33.7	0.9444 ₆	34.1	0.9444 ₆	34.4	0.9444 ₆	34.8	0.9444 ₆	35.1	0.9444 ₆	35.4	0.9444 ₆
	41.2	0.9917 ₅	41.6	0.9917 ₅	41.9	0.9917 ₅	42.2	0.9917 ₅	42.5	0.9917 ₅	42.7	0.9917 ₅
Hydrogen sulfide	21.3	0.9978 ₈	21.2	0.9978 ₈	21.3	0.9978 ₈
	26.1	0.9967 ₂	25.8	0.9967 ₄	25.7	0.9967 ₆	25.7	0.9967 ₆	25.8	0.9967 ₆
	27.9	0.9961 ₉	27.7	0.9962 ₀	27.5	0.9962 ₂	27.5	0.9962 ₃	27.5	0.9962 ₄	27.6	0.9962 ₅
	33.5	0.9944 ₇	33.0	0.9944 ₉	32.7	0.9945 ₁	32.4	0.9945 ₃	32.2	0.9945 ₄	32.1	0.9945 ₅
	41.0	0.9917 ₅	40.6	0.9917 ₅	40.2	0.9918 ₆	39.8	0.9918 ₂	39.5	0.9918 ₄	39.3	0.9918 ₅

where X and M are the mole fraction and molecular weight, respectively, ρ is the experimental density, and ρ^* is the density of pure solvent (water) at the experimental pressure. Densities of pure water under pressure corresponding to each experimental point were calculated with the integrated form of the Tait equation:

$$\rho = \rho_0 \exp \left(C \ln \frac{L + P}{L + P_0} \right) \quad (3)$$

where ρ_0 is the density at P_0 (1 atm) from the data of Gildseth et al. (10), and the constants L and C are given by Gibson and Loeffler (9) as a function of temperature. Solubility data for H₂S were taken from the same sources (3, 23) discussed in our previous report (13).

For nitrogen, the low solubility and consequent small density difference relative to pure water under pressure make our data of insufficient precision to permit satisfactory calculations of apparent molal volumes. The values of Φ_2 obtained by use of nitrogen solubilities interpolated from the data of Wiebe et al. (22) (which may not be the most accurate available but are in a convenient form), scatter between 20 and 50 cm³/mol, as could be expected since a temperature uncertainty of 0.1° corresponds to a variation of 5 cm³. They are, however, consistent with modern estimates (7, 18–20) of the partial molal volume of nitrogen in water, which range from 32 to 41 cm³/mol, for this temperature range. We are unable to comment on the sign of the temperature dependence, which seems to be uncertain, since Kritchevsky and Illinskaya (19) reported a decrease of 8% in \bar{V}_2 between 0° and 50°, whereas Kobayashi and Katz (18) found a 3% increase in the same range (and a further increase of nearly 10% to 100°).

For hydrogen sulfide, on the other hand, the density differences relative to water *under pressure* are appreciable, and the data do permit calculation of fairly precise apparent molal volumes. All values obtained fall in the range 35.1 ± 0.6 cm³/mol. No clear trends are apparent either with pressure or mole fraction of H₂S dissolved. If the apparent molal volumes are in fact independent of concentration to infinite dilution, these values closely approximate the partial molal volumes, as well. There does appear to be a slight increase with temperature, the average value near 21° being 34.7 cm³/mol and that at 40° being 35.5 cm³/mol; this difference is slightly larger than our experimental uncertainty. The results are shown in Figure 3, where each point corresponds to an experimental point from Figure 2.

It is of interest to compare the apparent molal volumes of dissolved H₂S with the molal volume of the pure liquid. For solutions of gases, however, the problem of the choice of reference state is particularly serious (5). Hildebrand et al. (14) have suggested the molal volume of the solute at its normal boiling point as the most appropriate. Alternatively, a "corresponding state," at the

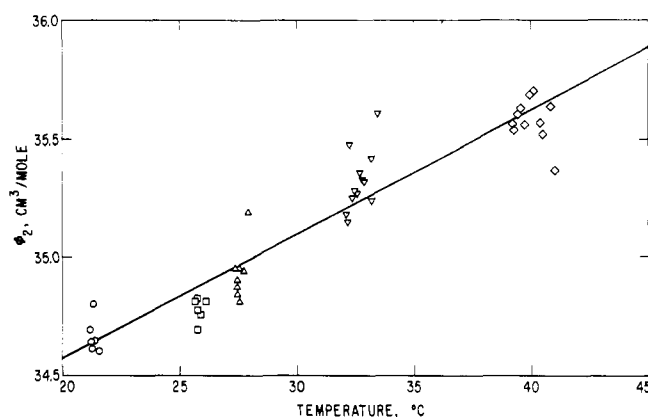

Figure 3. Apparent molal volumes of hydrogen sulfide in water, estimated from density measurements. Different symbols represent measurements with different floats (Figure 2). Straight line is least-squares fit to data

same ratio of the boiling point or critical temperature for the solute as the experimental temperature is for the solvent, can be considered. (Since the ratio of boiling point to critical temperature is nearly the same for H₂O and H₂S, either fraction leads to the same result.) These values are compared in Table II. The apparent molal volumes we have estimated are close to the molal volume of liquid H₂S at its normal boiling point but somewhat expanded over the "corresponding state" value. This might be interpreted as signifying that H₂S molecules are substantially inert in their effect on water structure, behaving much like hydrocarbon gases or nitrogen (14).

Viscosity. Following Hubbard and Brown (15), we may estimate viscosity from ball roll-time measurements using the expression:

$$\mu = B \frac{\rho_s - \rho}{v} \quad (4)$$

where ρ_s is the density of the ball, and B is an instrument constant. They showed that

$$B = \frac{5}{42} K g \sin \theta (D + d) \quad (5)$$

where θ is the tilt angle, g is the gravitational acceleration, and K is a correlation factor depending on d/D . For initial calibration of our instrument, we measured roll times with distilled water at 35.2°. The results are summarized in the first section of Table III. The tilt angle dependence is as expected, and the value of K is in good agreement with the correlation obtained by Hubbard and Brown. Using the average value of K , we have calculated the viscosity of water from measurements made at two other temperatures. The results, as shown in the bottom part of Table III, agree with literature values within 2%.

Table II. Molal Volumes of H₂S in Pure Liquid State

	T, K	V ₂ , cm ³ /mol
"Corresponding state"	170	33.6 ^a
Normal boiling point	213	35.9 ^b
Experimental temperature	294	43.3 ^{b,c}
	313	46.0 ^b
		46.5 ^c

^a Extrapolated from data of Klemenc and Bankowski (17) and Clarke and Glew (4). ^b Clarke and Glew (4). ^c Janik (16).

Table III. Calibration of Viscometer

Direction of tilt	Angle	Roll time, sec	Apparatus constant, K, Equation 5		
Water, 35.2°C					
Toward closed end	7.37°	154 ± 1	3.82 × 10 ⁻⁶		
From closed end	6.88°	165 ± 1	3.81 × 10 ⁻⁶		
t, °C	ρ _s -ρ, g/cm ³	Angle	Roll time, sec	μ Equation 5, cp	μ, lit. (11), cp
Measured viscosity of water, new data					
28.1	2.831	7.37°	175 ± 1	0.818	0.834
		6.88°	187 ± 1	0.821	0.801
30.0	2.832	7.37°	169 ± 1	0.790	
		6.88°	181 ± 1	0.795	

Table IV. Viscosity of Water Saturated with H₂S

t, °C	P, atm	τ/τ ₀ , Equation 6	Viscosity, cp
28.1	17.3	1.05 ₈	0.884
	17.9	1.03 ₈	0.864
	19.0	1.05 ₂	0.879
30.0	21.5	1.03 ₈	0.832
35.2	18.0	1.00 ₈	0.724

Following these calibration measurements, we measured roll times for water pressurized with nitrogen to 18 atm at 28.1° and 35.2°. In all cases, we could detect no difference from measurements at 1 atm, within our experimental error. This is consistent with the small pressure coefficient of the viscosity of water.

Table IV shows the average values of the ratios of roll times after pressurization with hydrogen sulfide (τ) to those observed at atmospheric pressure (τ₀). Since under these conditions the liquid density is almost the same as that of water at 1 atm, these also represent the corresponding viscosity ratios, i.e.,

$$\mu = \mu_0 (\tau/\tau_0) \quad (6)$$

The viscosities of the solutions calculated from literature values for the viscosity of water at corresponding temperatures are also given in Table IV.

The conditions at the two lower temperatures were selected as close as possible to those for the formation of the solid hydrate and also approximate the maximum solubility of H₂S in water. Accordingly, the largest effects on viscosity might be expected there. It appears from the present measurements that the viscosity increases by 3–6% (which is only slightly more than our experimental error). For practical purposes, this change is negligible.

While we do not wish to attempt detailed theoretical treatment of these few results, it is worth noting that they do not conform to simple additivity expressions for the

viscosity or fluidity of liquid mixtures. The viscosity of liquid hydrogen sulfide has been determined by Hennel and Krynicki (12); in the temperature range we have examined, the values (at saturation pressure) are 0.11–0.12 cP. Thus, on the basis of any additivity relations, we should expect a decrease in viscosity on saturation of water with H₂S, rather than an increase as we have observed.

With better provision for temperature control and timing, the two most serious sources of error in these measurements, this modification of the rolling-ball viscometer would seem very satisfactory for determining the viscosity of liquids equilibrated with gases under pressure.

Acknowledgment

We are grateful to C. S. Herrick for helpful discussions.

Nomenclature

- d* = diameter of ball in rolling-ball viscometer
D = diameter of tube in rolling-ball viscometer
M_i = molecular weight of component *i*
R_c = critical Reynolds number for streamline flow
t = temperature, °C
v = rolling velocity in rolling-ball viscometer
 \bar{V}_2 = partial molal volume of solute, component 2
X_i = mole fraction of component *i*
 Θ = tilt angle of rolling-ball viscometer
 μ = viscosity of liquid, experimental conditions
 μ_0 = viscosity of pure solvent at 1 atm
 ρ = density of liquid, experimental conditions
 ρ^* = density of pure solvent at experimental pressure
 ρ_0 = density of pure solvent at 1 atm
 ρ_s = density of ball in rolling-ball viscometer
 τ = roll time in rolling-ball viscometer
 τ_0 = roll time for pure solvent at 1 atm
 Φ_2 = apparent molal volume of solute, component 2

Literature Cited

- (1) Bebbington, W. P., Thayer, V. R., *Chem. Eng. Progr.*, **55** (9), 70 (1959).
- (2) Bridgeman, P. W., *Amer. J. Sci.*, **10**, 359 (1925).
- (3) Burgess, M. P., Germann, R. P., *AIChE J.*, **15**, 272 (1969).
- (4) Clarke, E. C. W., Glew, D. N., *Can. J. Chem.*, **48**, 764 (1970).
- (5) Conway, B. E., in "Hydrogen-Bonded Solvent Systems," A. K. Covington and P. Jones, Eds., p 222, Taylor and Francis, London, England, 1968.
- (6) Stalony-Dobrzanski, J., *Roczniki Chem.*, **17**, 353 (1937); *CA*, **31**, 8328 (1937).
- (7) Enns, T., Scholander, P. F., Bradstreet, E. D., *J. Phys. Chem.*, **69**, 389 (1965).
- (8) Galley, M. R., Miller, A. I., Atherley, J. F., Mohn, M., G.S. Process Physical Properties, AECL-4255, Chalk River Nuclear Laboratories, 1972.
- (9) Gibson, R. E., Loeffler, O. H., *J. Amer. Chem. Soc.*, **63**, 898 (1941).
- (10) Gildseth, W., Habenschuss, A., Spedding, F. H., *J. Chem. Eng. Data*, **17**, 402 (1972).
- (11) "Handbook of Chemistry and Physics," 44th ed., p 2257, Chemical Rubber Publ. Co., Cleveland, Ohio, 1962.
- (12) Hennel, J. W., Krynicki, K., *Acta Phys. Polon.*, **18**, 523 (1959).
- (13) Herrick, C. S., Gaines, Jr., G. L., *J. Phys. Chem.*, **77**, 2703 (1973).
- (14) Hildebrand, J. H., Prausnitz, J. M., Scott, R. L., "Regular and Related Solutions," Chap. 8, Van Nostrand Reinhold, New York, N.Y., 1970.
- (15) Hubbard, R. M., Brown, G. G., *Ind. Eng. Chem., Anal. Ed.*, **15**, 212 (1943).
- (16) Janik, J., *Acta Phys. Polon.*, **23**, 487 (1963).
- (17) Klemenc, A., Bankowski, O., *Z. Anorg. Chem.*, **208**, 348 (1932).
- (18) Kobayashi, R., Katz, D. L., *Ind. Eng. Chem.*, **45**, 440 (1953).
- (19) Kritchevsky, I., Illiinskaya, A., *Acta Physicochim. URSS*, **20**, 327 (1945).
- (20) Lauder, I., *Aust. J. Chem.*, **12**, 40 (1959).
- (21) Masterton, W. L., Robins, D. A., Slowinski, Jr., E. J., *J. Chem. Eng. Data*, **6**, 531 (1961).
- (22) Wiebe, R., Gaddy, V. L., Heins, Jr., C., *J. Amer. Chem. Soc.*, **55**, 947 (1933).
- (23) Wright, R. H., Maass, O., *Can. J. Res.*, **6**, 94 (1932).

Received for review January 24, 1974. Accepted July 1, 1974.